

STATE OF ILLINOIS
DEPARTMENT OF TRANSPORTATION

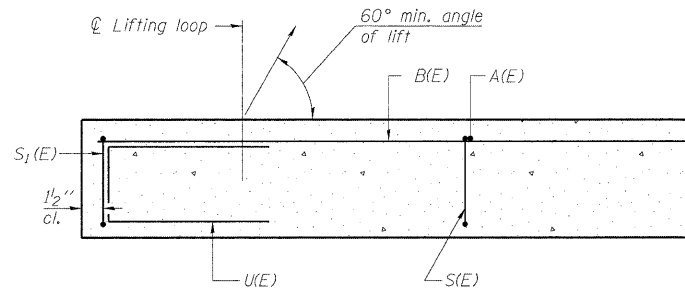

SECTION C-C

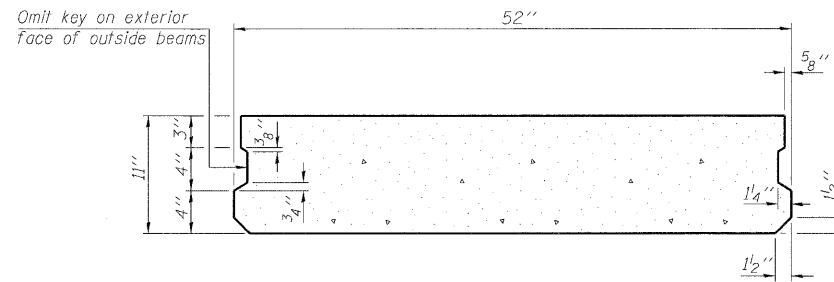

SECTION A-A
(Showing dimensions)

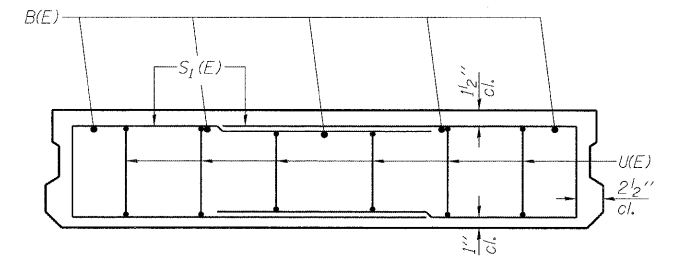

VIEW B-B

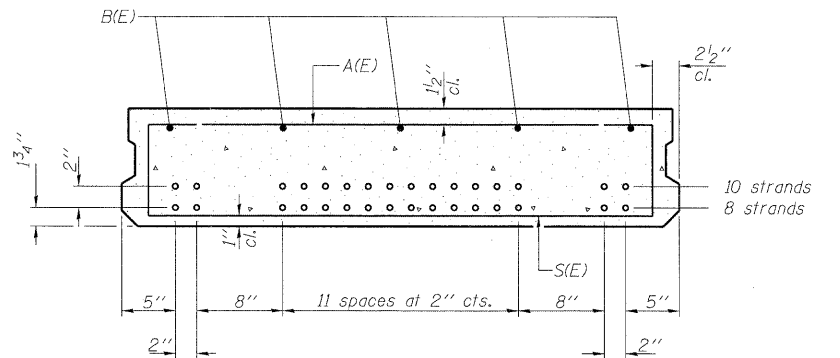

SECTION A-A

(Showing reinforcement and permissible strand locations)
Note: Place the number of strands specified in each row symmetrically about the centerline of beam in the permissible strand locations shown.

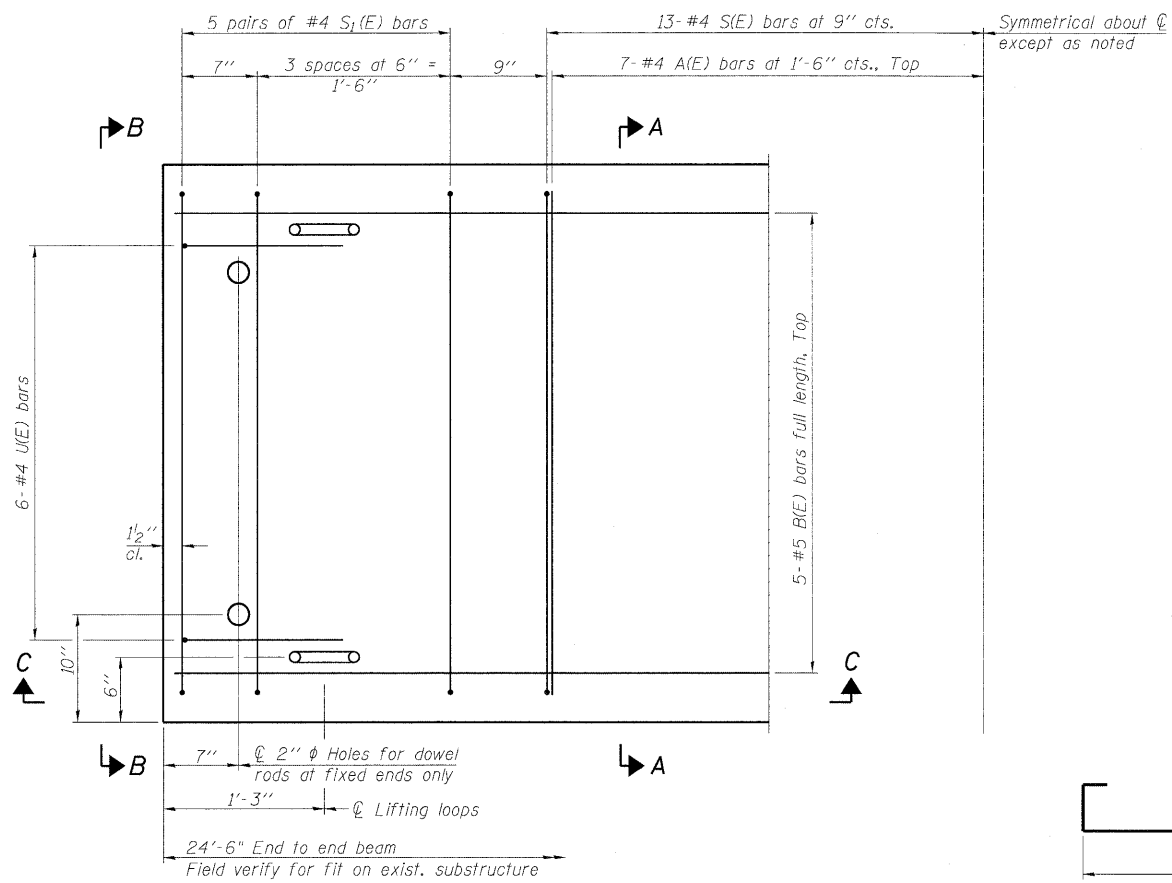

PLAN VIEW

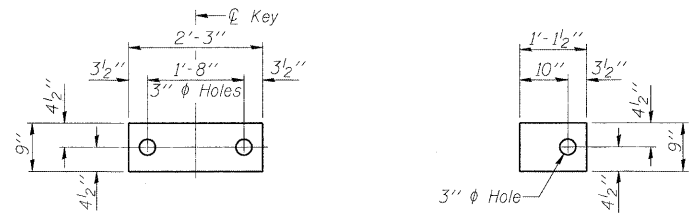

FABRIC BEARING PAD
(Interior)

FABRIC BEARING PAD
(Exterior)

FIXED

Notes:
All bearing pads shall be 1 inch thick.
Omit holes when using expansion bearings.
Expansion bearing pad shall be bonded to the substructure.

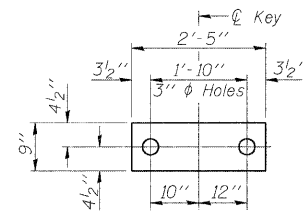

FABRIC BEARING PAD

(Where beams change from 52" to 48")

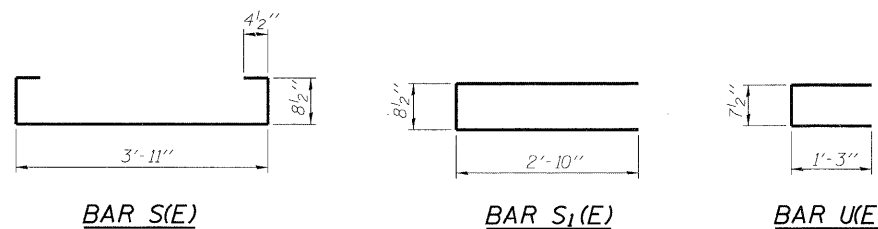

BAR S(E)

BAR S1(E)

BAR U(E)

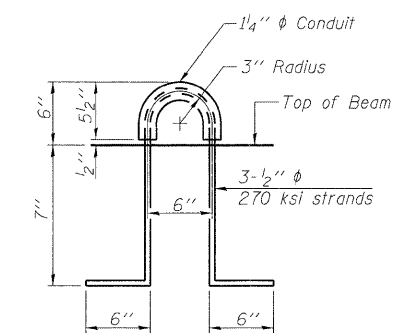

LIFTING LOOP DETAIL

BAR LIST
ONE BEAM ONLY
(For information only)

Bar	No.	Size	Length	Shape
A(E)	14	#4	3'-11"	—
B(E)	5	#5	24'-2"	—
S(E)	26	#4	6'-1"	U
S1(E)	20	#4	6'-5"	U
U(E)	12	#4	3'-2"	U

BILL OF MATERIAL

Precast Prestressed Conc. Deck Bms. (11" depth)	Sq. Ft.	1062
---	---------	------

NOTES

Prestressing steel shall be uncoated high strength, low relaxation 7-wire strand, Grade 270. The nominal diameter shall be 1/2 inch and the nominal cross-sectional area shall be 0.153 sq. in. Reinforcement bars shall conform to ASTM A 706, Grade 60. (See Special Provisions). Two 1/8 inch fabric adjusting shims of the dimensions of the exterior bearing pad shall be provided for each bearing pad location. A minimum 2 1/2 inch diameter lifting pin shall be used to engage the lifting loops during handling. Corrosion Inhibitor, per Article 1020.05(b)(12) and 1021.06 of the Standard Specifications, shall be used in the concrete for precast prestressed concrete deck beams. Compressive strength of prestressed concrete, f'c, shall be 6000 psi. Compressive strength of prestressed concrete at release, f'ci, shall be 5000 psi. See sheet S14 of S17 for 11"x48" PPC Deck Beams.

DESIGNED	SLV
CHECKED	DJB
DRAWN	SLV
CHECKED	DJB

LONCO, INC.
CONSULTING ENGINEERS
1560 WALL ST., SUITE 222
NAPERVILLE, ILLINOIS 60563 PH: (630) 577-9100

11" x 52" PPC DECK BEAMS
STRUCTURE NO. 049-0152

SHEET NO. S13 OF S17 SHEETS	F.A.P. RTE.	SECTION	COUNTY	TOTAL SHEETS	SHEET NO.
	338	108 B-1	LAKE	40	25
		D-91-289-09	CONTRACT NO. 60F92		
		FED. ROAD DIST. NO.	ILLINOIS	FED. AID PROJECT	