

STATE OF ILLINOIS
DEPARTMENT OF TRANSPORTATION
DIVISION OF HIGHWAYS

**PROPOSED
HIGHWAY PLANS**

FAP 352: IL 137
BUTTERFIELD RD. TO IL 21 (MILWAUKEE AVE.)
SECTION 2R-1-RS-1
RESURFACING (3P)
LAKE COUNTY
C-91-465-11

FOR INDEX OF SHEETS, SEE SHEET NO. 2

PROJECT IS LOCATED IN
THE VILLAGE OF LIBERTYVILLE

F.A.P. RTE.	SECTION	COUNTY	TOTAL SHEETS	SHEET NO.
352	2R-1-RS-1	LAKE	24	1
ILLINOIS			CONTRACT NO. 60P11	

D-91-465-11

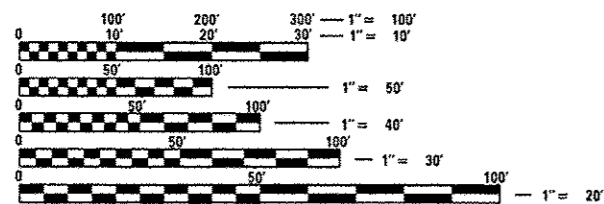
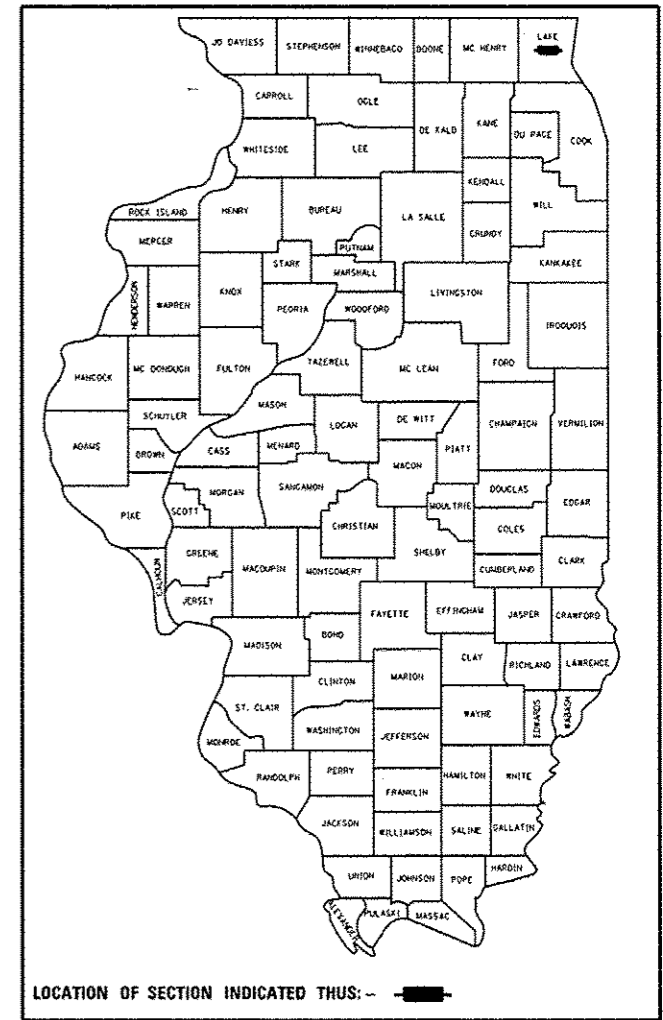

FULL SIZE PLANS HAVE BEEN PREPARED USING STANDARD ENGINEERING SCALES. REDUCED SIZED PLANS WILL NOT CONFORM TO STANDARD SCALES. IN MAKING MEASUREMENTS ON REDUCED PLANS, THE ABOVE SCALES MAY BE USED.

J.U.L.I.E.
JOINT UTILITY LOCATION INFORMATION FOR EXCAVATION
1-800-892-0123
OR 811

PROJECT BEGINS:
STATION 4+74

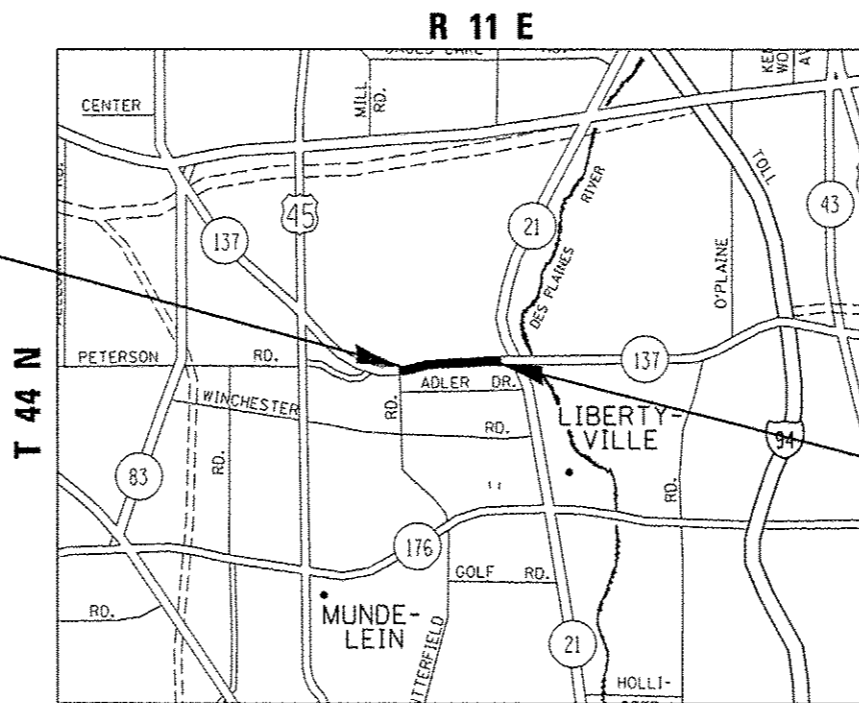

TRAFFIC DATA:
SPEED LIMIT = 40 - 45 MPH
2011 ADT = 29,900

PROJECT ENDS:
STATION 63+64

LIBERTYVILLE TOWNSHIP

GROSS & NET LENGTH = 5,890 FEET = 1.12 MILES

PROJECT ENGINEER: DAN WILGREEN (847) 705-4240
PROJECT MANAGER: KEN ENG (847) 705-4247

CONTRACT NO. 60P11

STATE OF ILLINOIS
DEPARTMENT OF TRANSPORTATION
DIVISION OF HIGHWAYS

SUBMITTED JUNE 9 2014

John D. Balanzelli, P.E.
DEPUTY DIRECTOR OF HIGHWAYS, REGION ENGINEER

July 18 2014
John D. Balanzelli, P.E.
ENGINEER OF DESIGN AND ENVIRONMENT

July 18 2014
Omer Osman, P.E.
DIRECTOR OF HIGHWAYS, CHIEF ENGINEER

PRINTED BY THE AUTHORITY
OF THE STATE OF ILLINOIS

INDEX OF SHEETS

STATE STANDARDS

GENERAL NOTES

<u>SHEET NO.</u>	<u>DESCRIPTION</u>	<u>STANDARD NO.</u>	<u>DESCRIPTION</u>
1	COVER SHEET	000001-06	TYPICAL SYMBOLS, ABBREVIATIONS AND PATTERNS
2	INDEX OF SHEETS, STATE STANDARDS & GENERAL NOTES	442201-03	CLASS C AND D PATCHES
3-4	SUMMARY OF QUANTITIES	604001-03	FRAME AND LIDS, TYPE 1
5-6	EXISTING AND PROPOSED TYPICAL SECTIONS	604091-02	FRAME AND GRATE, TYPE 24
7-9	ROADWAY AND PAVEMENT MARKING PLANS	606001-05	CONCRETE CURB AND COMBINATION CONCRETE CURB AND GUTTER
10-12	DETECTOR LOOP REPLACEMENT PLANS	701101-04	OFF-RD OPERATIONS, MULTILANE, 15' (4.5m) TO 24' (600mm) FROM PAVEMENT EDGE
13	DETAILS FOR FRAME AND LIDS ADJUSTMENT WITH MILLING (BD-08)	701421-06	LANE CLOSURE, MULTILANE, DAY OPERATIONS ONLY, FOR SPEEDS >= 45MPH TO 55MPH
14	PAVEMENT PATCHING FOR HMA SURFACED PAVEMENT (BD-22)	701426-06	LANE CLOSURE, MULTILANE, INTERMITTENT OR MOVING OPERATION, FOR SPEEDS > 45MPH
15	CURB OR CURB AND GUTTER REMOVAL AND REPLACEMENT (BD-24)	701427-02	LANE CLOSURE, MULTILANE, INTERMITTENT OR MOVING OPERATION, FOR SPEEDS < 40MPH
16	BUTT JOINT AND HMA TAPER DETAILS (BD-32)	701601-09	URBAN LANE CLOSURE, MULTILANE, 1W OR 2W WITH NONTRAVERSABLE MEDIAN
17	TRAFFIC CONTROL AND PROTECTION FOR SIDE ROADS, INTERSECTIONS AND DRIVEWAYS (TC-10)	701602-07	URBAN LANE CLOSURE, MULTILANE, 2W WITH BIDIRECTIONAL LEFT TURN LANE
18	TYPICAL APPLICATIONS: RAISED REFLECTIVE PAVEMENT MARKERS (SNOW-PLOW RESISTANT) (TC-11)	701701-09	URBAN LANE CLOSURE, MULTILANE INTERSECTION
19	DISTRICT ONE TYPICAL PAVEMENT MARKINGS (TC-13)	701901-03	TRAFFIC CONTROL DEVICES
20	TRAFFIC CONTROL AND PROTECTION OF TURN BAYS (TO REMAIN OPEN TO TRAFFIC) (TC-14)	886001-01	DETECTOR LOOP INSTALLATION
21	PAVEMENT MARKING LETTERS AND SYMBOLS FOR TRAFFIC STAGING (TC-16)	886006-01	TYPICAL LAYOUT FOR DETECTION LOOPS
22	ARTERIAL INFORMATION SIGNING (TC-22)		
23	DISTRICT ONE STANDARD TRAFFIC SIGNAL DESIGN DETAILS (TS-05)		
24	DISTRICT ONE DETECTOR LOOP INSTALLATION DETAILS FOR ROADWAY RESURFACING (TS-07)		

BEFORE STARTING ANY EXCAVATION, THE CONTRACTOR SHALL CALL "JULIE" AT (800) 892-0123 OR 811 FOR FIELD LOCATIONS OF BURIED ELECTRIC, TELEPHONE, AND GAS FACILITIES. (48 HOUR NOTIFICATION REQUIRED)

THE CONTRACTOR WILL NOT BE ABLE TO SET UP A YARD OR FIELD OFFICE ON STATE PROPERTY WITHOUT THE WRITTEN PERMISSION OF THE DEPARTMENT.

THE CONTRACTOR SHALL COORDINATE CONSTRUCTION ACTIVITIES WITH UTILITY COMPANIES AND THE VILLAGE OF LIBERTYVILLE.

BUTT JOINTS WILL BE INSTALLED AT THE ENDS OF RESURFACING (WHERE RESURFACING MEETS EXISTING PAVEMENT) IN ACCORDANCE WITH THE "BUTT JOINT AND HMA TAPER DETAILS" SHEET INCLUDED IN THE PLANS UNLESS OTHERWISE SPECIFIED.

WHEN MILLED PAVEMENT IS OPEN TO TRAFFIC, THE MAXIMUM GRADE DIFFERENTIAL BETWEEN PASSES OF THE MILLING MACHINE SHALL NOT EXCEED 1/2 INCHES WHERE THE SPEED LIMIT IS 45 MPH OR LESS, AND 1 INCH WHERE THE SPEED LIMIT IS OVER 45 MPH. WITH WRITTEN APPROVAL FROM THE RESIDENT ENGINEER, A MAXIMUM GRADE DIFFERENTIAL OF 3 INCHES MAY BE ALLOWED IF THE EDGE OF THE MILLING IS SLOPED A MINIMUM OF 1:3 (V:H).

WHEN ARTIFICIAL LIGHTING IS UTILIZED IN NIGHT OPERATIONS, THE CONTRACTOR SHALL EXERCISE THE UTMOST PRECAUTIONS IN PREVENTING ADVERSE VISIBILITY TO THE MOTORING PUBLIC AND ADJOINING RESIDENTIAL AREAS.

ALL PAVEMENT PATCHING LOCATIONS WILL BE DETERMINED IN THE FIELD BY THE ENGINEER.

BEFORE BEGINNING ANY WORK, THE CONTRACTOR SHALL RETAIN AND RECORD FOR FUTURE REFERENCE, ALL EXISTING PAVEMENT MARKING LINES (AND RAISED REFLECTIVE PAVEMENT MARKERS) IN ORDER THAT THESE LOCATIONS CAN BE RE-ESTABLISHED FOR STRIPING. EXACT LOCATIONS OF ALL PAVEMENT MARKINGS SHALL BE AS DIRECTED BY THE ENGINEER.

DOUBLE LANE MARKERS ARE TO BE USED AS SHOWN ON THE DISTRICT ONE DETAIL "TYPICAL APPLICATIONS - RAISED REFLECTIVE PAVEMENT MARKERS (SNOW-PLOW RESISTANT)" SHOWN IN THE PLANS.

THE RESIDENT ENGINEER SHALL CONTACT WALTER CZARNY, AREA TRAFFIC FIELD ENGINEER, AT (847) 715-8419 A MINIMUM OF 2 WEEKS PRIOR TO PLACEMENT OF FINAL PAVEMENT MARKINGS.

THE CONTRACTOR SHALL CONTACT THE IDOT TRAFFIC CONTROL SUPERVISOR AT (847) 705-4470 A MINIMUM OF 72 HOURS IN ADVANCE OF BEGINNING WORK.

FILE NAME :	USER NAME : philipdo	DESIGNED -	REVISED -	STATE OF ILLINOIS DEPARTMENT OF TRANSPORTATION	IL 137 (BUTTERFIELD RD. TO IL 21 (MILWAUKEE AVE.)) INDEX OF SHEETS, STATE STANDARDS & GENERAL NOTES	F.A.P. RTE.	SECTION	COUNTY	TOTAL SHEETS	SHEET NO.	
...	...	DRAWN -	REVISED -			352	2R-1-RS-1	LAKE	24	2	
...	...	CHECKED -	REVISED -			CONTRACT NO. 60P11					
...	...	DATE -	REVISED -			SCALE: NONE	SHEET NO. 2 OF 24 SHEETS	STA. TO STA.	ILLINOIS FED. AID PROJECT		

URBAN

URBAN

SUMMARY OF QUANTITIES			CONSTRUCTION TYPE CODE					
CODE NO	ITEM	UNIT	TOTAL QUANTITIES	100% STATE 0005				
21101615	TOPSOIL FURNISH AND PLACE, 4"	SQ YD	155	155				
25200110	SODDING, SALT TOLERANT	SQ YD	155	155				
40600400	MIXTURE FOR CRACKS, JOINTS, AND FLANGEWAYS	TON	84	84				
40600827	POLYMERIZED LEVELING BINDER (MACHINE METHOD), IL-4.75, N50	TON	2234	2234				
40600895	CONSTRUCTING TEST STRIP	EACH	1	1				
40600982	HOT-MIX ASPHALT SURFACE REMOVAL - BUTT JOINT	SQ YD	242	242				
40603595	POLYMERIZED HOT-MIX ASPHALT SURFACE COURSE, MIX "F", N90	TON	5489	5489				
42001300	PROTECTIVE COAT	SQ YD	207	207				
44000159	HOT-MIX ASPHALT SURFACE REMOVAL, 2 1/2"	SQ YD	55447	55447				
44201789	CLASS D PATCHES, TYPE II, 12 INCH	SQ YD	768	768				
44201794	CLASS D PATCHES, TYPE III, 12 INCH	SQ YD	400	400				
44201796	CLASS D PATCHES, TYPE IV, 12 INCH	SQ YD	125	125				
48102100	AGGREGATE WEDGE SHOULDER, TYPE B	TON	402	402				
60257900	MANHOLES TO BE RECONSTRUCTED	EACH	1	1				

SUMMARY OF QUANTITIES			CONSTRUCTION TYPE CODE					
CODE NO	ITEM	UNIT	TOTAL QUANTITIES	100% STATE 0005				
60262700	INLETS TO BE RECONSTRUCTED	EACH	1	1				
60300105	FRAMES AND GRATES TO BE ADJUSTED	EACH	7	7				
60404950	FRAMES AND GRATES, TYPE 24	EACH	7	7				
60406100	FRAMES AND LIDS, TYPE I, CLOSED LID	EACH	3	3				
67000400	ENGINEER'S FIELD OFFICE, TYPE A	CAL MO	6	6				
67100100	MOBILIZATION	L SUM	1	1				
70100310	TRAFFIC CONTROL AND PROTECTION, STANDARD 701421	L SUM	1	1				
70102630	TRAFFIC CONTROL AND PROTECTION, STANDARD 701601	L SUM	1	1				
70102632	TRAFFIC CONTROL AND PROTECTION, STANDARD 701602	L SUM	1	1				
70102635	TRAFFIC CONTROL AND PROTECTION, STANDARD 701701	L SUM	1	1				
70300100	SHORT TERM PAVEMENT MARKING	FOOT	10164	10164				
70300210	TEMPORARY PAVEMENT MARKING LETTERS AND SYMBOLS	SQ FT	1076	1076				
70300220	TEMPORARY PAVEMENT MARKING - LINE 4"	FOOT	27515	27515				

FILE NAME :	USER NAME : pvt10pds	DESIGNED -	REVISED -	STATE OF ILLINOIS DEPARTMENT OF TRANSPORTATION	IL 137 (BUTTERFIELD RD. TO IL 21 (MILWAUKEE AVE.)) SUMMARY OF QUANTITIES	F.A. RTE. :	SECTION :	COUNTY :	TOTAL SHEETS :	SHEET NO. :	
C:\pvt10pds\pvt10pds\0276648\046511\111\pvt10pds		DRAWN -	REVISED -			352	2R-1-RS-1	LAKE	24	3	
PLOT SCALE * 1000000' / 1"		CHECKED -	REVISED -			CONTRACT NO. 60P11					
PLOT DATE * 6/9/2014		DATE -	REVISED -			SCALE:	SHEET NO. 3 OF 24 SHEETS	STA.	TO STA.	FED. ROAD DIST. NO. 1 [ILLINOIS] FED. AID PROJECT	

URBAN

URBAN

SUMMARY OF QUANTITIES			CONSTRUCTION TYPE CODE					
CODE NO	ITEM	UNIT	TOTAL QUANTITIES	100% STATE				
				0005				
70300240	TEMPORARY PAVEMENT MARKING - LINE 6"	FOOT	3679	3679				
70300250	TEMPORARY PAVEMENT MARKING - LINE 8"	FOOT	336	336				
70300260	TEMPORARY PAVEMENT MARKING - LINE 12"	FOOT	3008	3008				
70300280	TEMPORARY PAVEMENT MARKING - LINE 24"	FOOT	331	331				
70301000	WORK ZONE PAVEMENT MARKING REMOVAL	SO FT	3388	3388				
* 78000100	THERMOPLASTIC PAVEMENT MARKING - LETTERS AND SYMBOLS	SD FT	1076	1076				
* 78000200	THERMOPLASTIC PAVEMENT MARKING - LINE 4"	FOOT	27515	27515				
* 78000400	THERMOPLASTIC PAVEMENT MARKING - LINE 6"	FOOT	3979	3979				
* 78000500	THERMOPLASTIC PAVEMENT MARKING - LINE 8"	FOOT	336	336				
* 78000600	THERMOPLASTIC PAVEMENT MARKING - LINE 12"	FOOT	3008	3008				
* 78000650	THERMOPLASTIC PAVEMENT MARKING - LINE 24"	FOOT	331	331				
* 78100100	RAISED REFLECTIVE PAVEMENT MARKER	EACH	590	590				

SUMMARY OF QUANTITIES			CONSTRUCTION TYPE CODE					
CODE NO	ITEM	UNIT	TOTAL QUANTITIES	100% STATE				
				0005				
78300200	RAISED REFLECTIVE PAVEMENT MARKER REMOVAL	EACH	537	537				
* 88600600	DETECTOR LOOP REPLACEMENT	FOOT	1729	1729				
X2020110	GRADING AND SHAPING SHOULDERS	UNIT	201	201				
40800025	BITUMINOUS MATERIALS (PRIME COAT)	POUND	37274	37274				
X5537800	STORM SEWERS TO BE CLEANED 12"	FOOT	100	100				
X6030310	FRAMES AND LIDS TO BE ADJUSTED (SPECIAL)	EACH	5	5				
Z0004562	COMBINATION CONCRETE CURB AND GUTTER REMOVAL AND REPLACEMENT	FOOT	930	930				
Z0018500	DRAINAGE STRUCTURES TO BE CLEANED	EACH	8	8				
Z0030850	TEMPORARY INFORMATION SIGNING	SO FT	52	52				

* SPECIALTY ITEMS

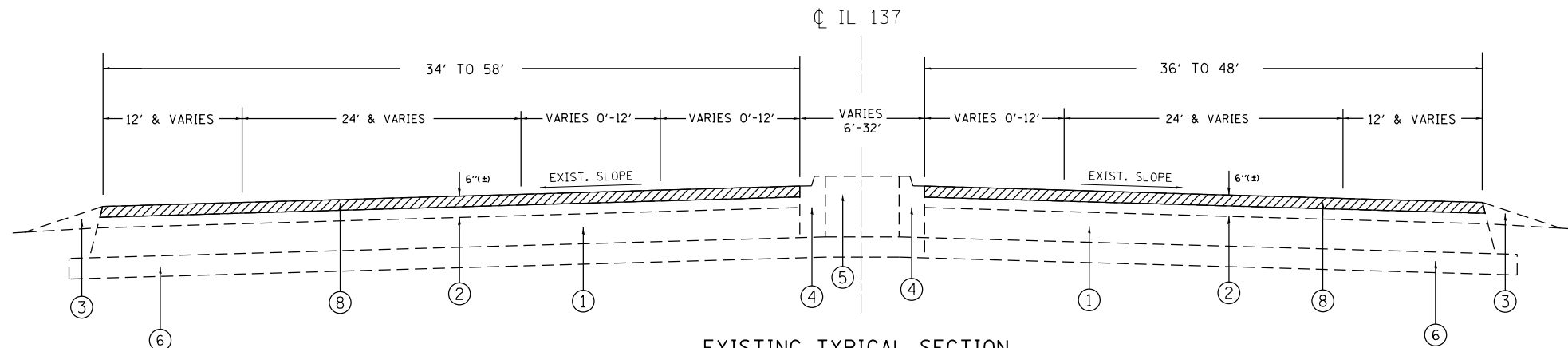

EXISTING TYPICAL SECTION
IL 137
STATION:
4+74 TO 45+80

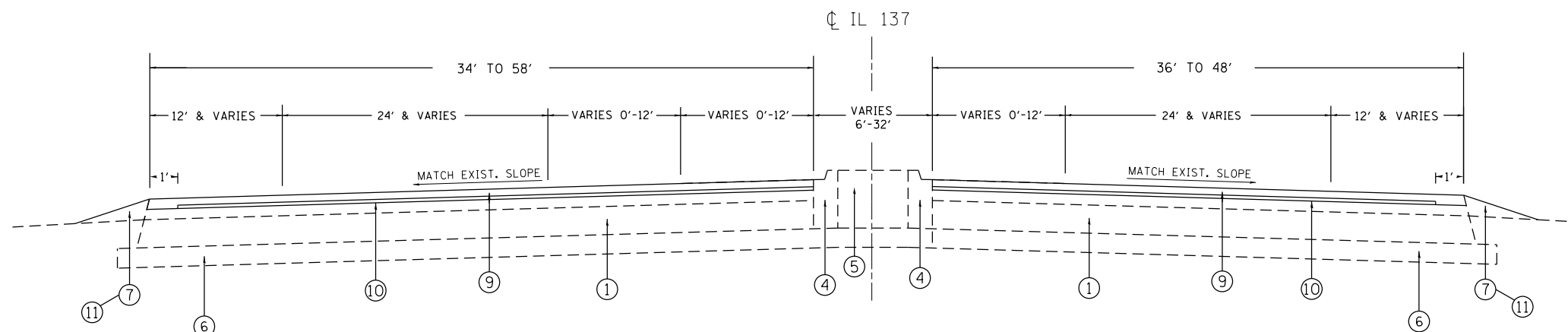

PROPOSED TYPICAL SECTION
IL 137
STATION:
4+74 TO 45+80

NOTES:

1. SEE ROADWAY AND PAVEMENT MARKING PLAN SHEETS FOR LOCATIONS OF LEFT TURN LANES AND PAINTED MEDIANS.
2. MILLING TO BE DONE PRIOR TO PATCHING. (SEE 'PAVEMENT PATCHING FOR HMA SURFACED PAVEMENT' DETAIL).
3. COMBINATION CONCRETE CURB AND GUTTER REMOVAL AND REPLACEMENT WILL BE DONE BETWEEN STATIONS: 5+35 TO 8+60, 13+49 TO 14+22, 15+16 TO 19+62 & 26+60 TO 28+85 (RIGHT SIDE ONLY)

LEGEND

- ① EXIST. PCC BASE COURSE, 8''(±)
- ② EXIST. HOT-MIX ASPHALT SURFACE (BEFORE MILLING), 6''(±)
- ③ EXIST. AGGREGATE SHOULDER TYPE B
- ④ EXIST. CONCRETE CURB AND GUTTER TYPE M-6.06
- ⑤ EXIST. STABILIZED MEDIAN 12''(±)
- ⑥ EXIST. HOT-MIX ASPHALT SUBBASE MATERIAL 4''(±)
- ⑦ PROP. AGGREGATE WEDGE SHOULDER, TYPE B
- ⑧ PROP. HOT-MIX ASPHALT SURFACE REMOVAL - 2 1/2''
- ⑨ PROP. POLYMERIZED HOT-MIX ASPHALT SURFACE COURSE, MIX "F", N90, 1 3/4''
- ⑩ PROP. POLYMERIZED LEVELING BINDER (MM), IL-4.75, N50, 3/4''
- ⑪ PROP. GRADING AND SHAPING SHOULDERS

HOT-MIX ASPHALT MIXTURE REQUIREMENTS

	MIXTURE TYPE	AIR VOIDS (%) @ NDES	QMP
ROADWAY	POLYMERIZED HOT-MIX ASPHALT SURFACE COURSE, MIX "F", N90, (IL-9.5MM), 1 3/4''	4% @ 90 GYR	QCP
	POLYMERIZED LEVELING BINDER (MM), IL-4.75, N50, 3/4''	3.5% @ 50 GYR	QCP
PATCHES	CLASS D PATCHES (HMA BINDER IL-19 mm)	4% @ 70 GYR	QC/QA

QMP DESIGNATION: QUALITY CONTROL/ QUALITY ASSURANCE (QC/QA); QUALITY CONTROL FOR PERFORMANCE (QCP)

THE UNIT WEIGHT USED TO CALCULATE ALL HMA SURFACE MIXTURE QUANTITIES IS 112 LBS/SQ YD/IN.

THE "AC TYPE" FOR ALL POLYMERIZED HMA MIXES SHALL BE "SBS/SBR PG 76-22 AND FOR NON-POLYMERIZED HMA THE "AC TYPE" SHALL BE PG 64-22" UNLESS MODIFIED BY DISTRICT ONE SPECIAL PROVISIONS. FOR USE OF RECYCLED MATERIALS SEE DISTRICT ONE SPECIAL PROVISIONS.

QUALITY MANAGEMENT PROGRAM (QMP) COLUMN IDENTIFIES THE TYPE OF SPECIFICATION THAT APPLIES TO THE HMA MIXTURE

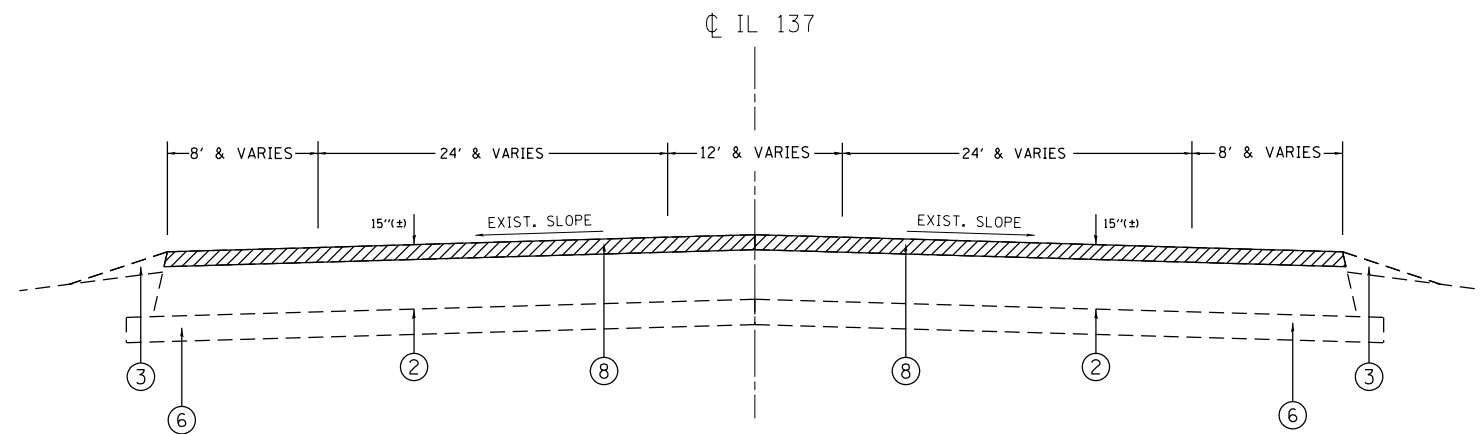

EXISTING TYPICAL SECTION
IL 137
STATION:
45+80 TO 63+64

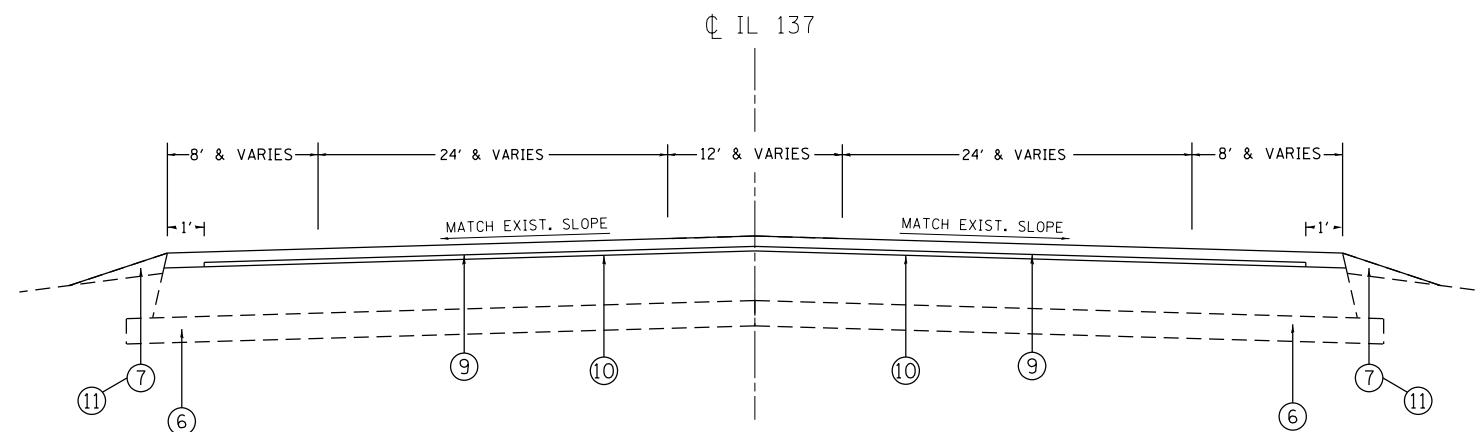

PROPOSED TYPICAL SECTION
IL 137
STATION:
45+80 TO 63+64

LEGEND

- ① EXIST. PCC BASE COURSE, 8''(±)
- ② EXIST. HOT-MIX ASPHALT PAVEMENT (BEFORE MILLING), 15''(±)
- ③ EXIST. AGGREGATE SHOULDER TYPE B
- ④ EXIST. CONCRETE CURB AND GUTTER TYPE M-6.06
- ⑤ EXIST. STABILIZED MEDIAN 12''(±)
- ⑥ EXIST. HOT-MIX ASPHALT SUBBASE MATERIAL 4''(±)
- ⑦ PROP. AGGREGATE WEDGE SHOULDER, TYPE B
- ⑧ PROP. HOT-MIX ASPHALT SURFACE REMOVAL - 2 1/2''
- ⑨ PROP. POLYMERIZED HOT-MIX ASPHALT SURFACE COURSE, MIX "F", N90, 1 3/4''
- ⑩ PROP. POLYMERIZED LEVELING BINDER (MM), IL-4.75, N50, 3/4''
- ⑪ PROP. GRADING AND SHAPING SHOULDERS

NOTES:

1. SEE ROADWAY AND PAVEMENT MARKING PLAN SHEETS FOR LOCATIONS OF LEFT TURN LANES AND PAINTED MEDIANS.
2. MILLING TO BE DONE PRIOR TO PATCHING. (SEE 'PAVEMENT PATCHING FOR HMA SURFACED PAVEMENT' DETAIL).

FILE NAME =	USER NAME = phillipsdo	DESIGNED -	REVISED -	STATE OF ILLINOIS DEPARTMENT OF TRANSPORTATION	IL 137 (BUTTERFIELD RD. TO IL 21 (MILWAUKEE AVE.)) EXISTING AND PROPOSED TYPICAL SECTIONS	F.A.P. RTE.	SECTION	COUNTY	TOTAL SHEETS	SHEET NO.	
et:\pwork\pwork\phillipsdo\d0276648\DI	6511-sht-plen.dgn	DRAWN -	REVISED -			352	2R-1-RS-1	LAKE	24	6	
	PLOT SCALE = 100.0000' / in.	CHECKED -	REVISED -			CONTRACT NO. 60P11					
	PLOT DATE = 6/9/2014	DATE -	REVISED -			ILLINOIS FED. AID PROJECT					
					SCALE:	SHEET 6 OF 24 SHEETS		STA.	TO STA.		

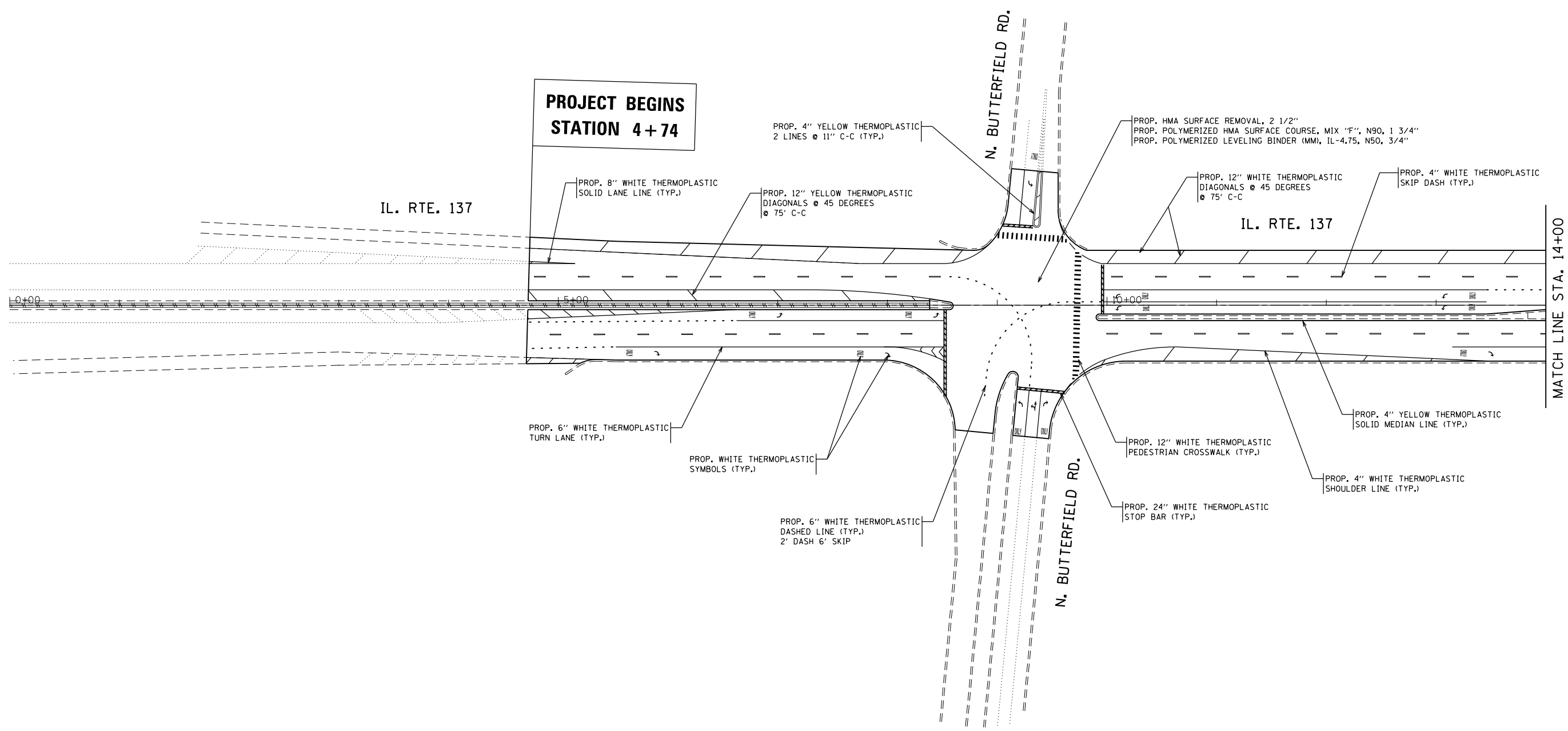

FILE NAME =	USER NAME = phillipsdo	DESIGNED -	REVISED -
et:\pwork\pwork\phillipsdo\d0276648\DI	6511-sht-pln.dgn	DRAWN -	REVISED -
	PLOT SCALE = 100.0000' / in.	CHECKED -	REVISED -
	PLOT DATE = 6/9/2014	DATE -	REVISED -

**STATE OF ILLINOIS
DEPARTMENT OF TRANSPORTATION**

**IL 137 (BUTTERFIELD RD. TO IL 21 (MILWAUKEE AVE.))
ROADWAY & PAVEMENT MARKINGS PLANS**

SCALE: SHEET 7 OF 24 SHEETS STA. TO STA.

F.A.P. RTE.	SECTION	COUNTY	TOTAL SHEETS	SHEET NO.
352	2R-1-RS-1	LAKE	24	7
CONTRACT NO. 60P11				
ILLINOIS FED. AID PROJECT				

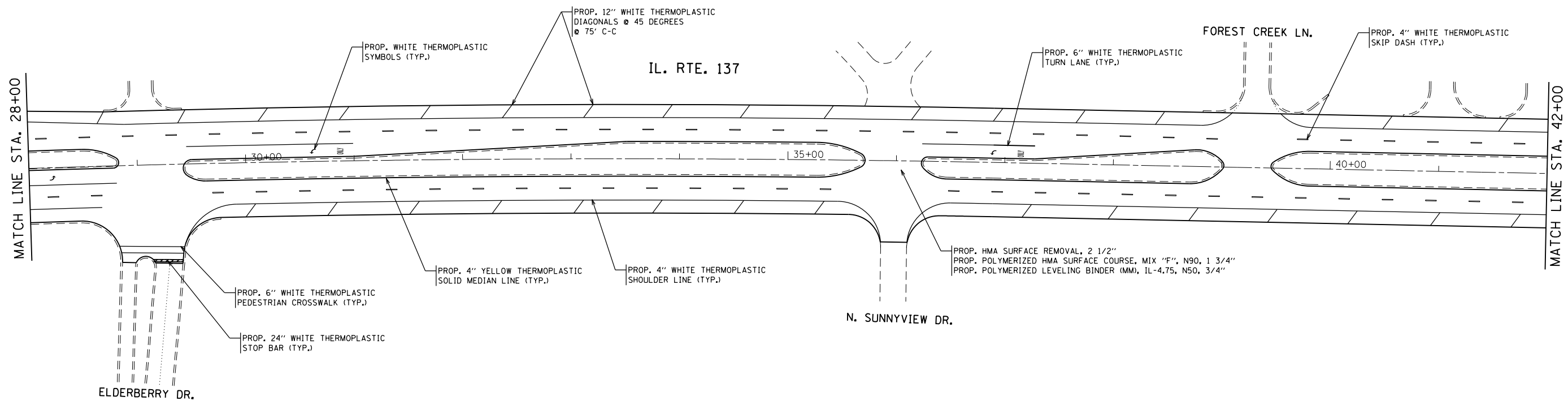
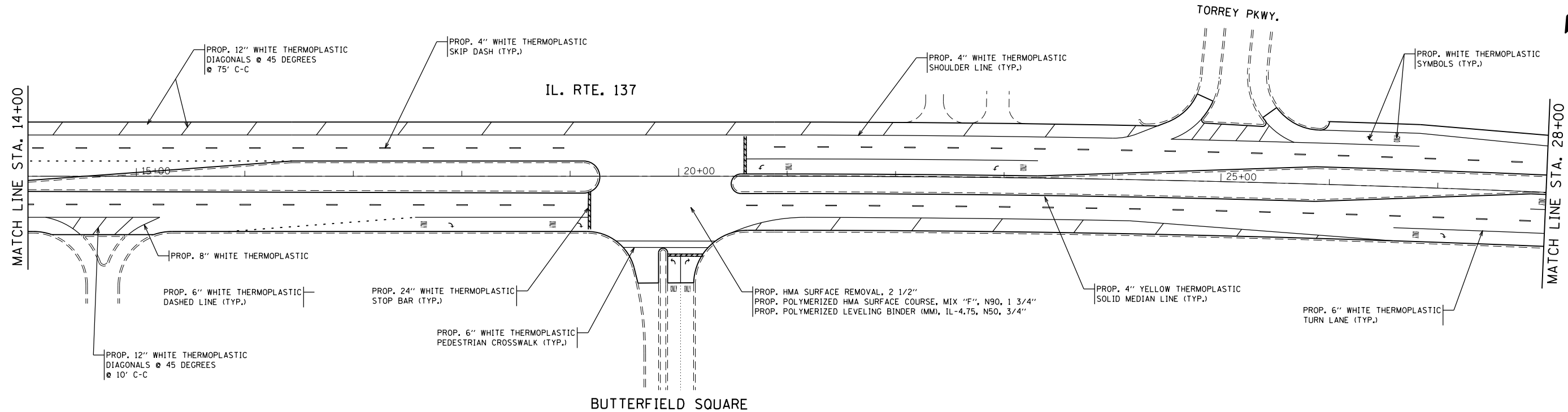

FILE NAME =	USER NAME = phillipso	DESIGNED -	REVISED -
et:\pw\work\p\dot\phillipso\d0276648\DI	6511-sht-plan.dgn	DRAWN -	REVISED -
	PLOT SCALE = 100.0000' / in.	CHECKED -	REVISED -
	PLOT DATE = 6/9/2014	DATE -	REVISED -

**STATE OF ILLINOIS
DEPARTMENT OF TRANSPORTATION**

**IL 137 (BUTTERFIELD RD. TO IL 21 (MILWAUKEE AVE.))
ROADWAY & PAVEMENT MARKINGS PLANS**

SCALE: SHEET 8 OF 24 SHEETS STA. 4+74 TO STA.

F.A.P. RTE.	SECTION	COUNTY	TOTAL SHEETS	SHEET NO.
352	2R-1-RS-1	LAKE	24	8
CONTRACT NO. 60P11				
ILLINOIS FED. AID PROJECT				

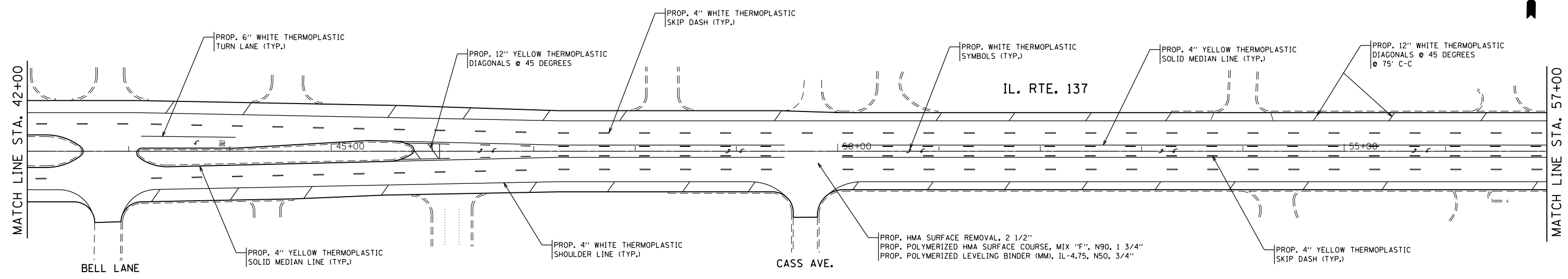

**PROJECT ENDS
STATION 63 + 64**

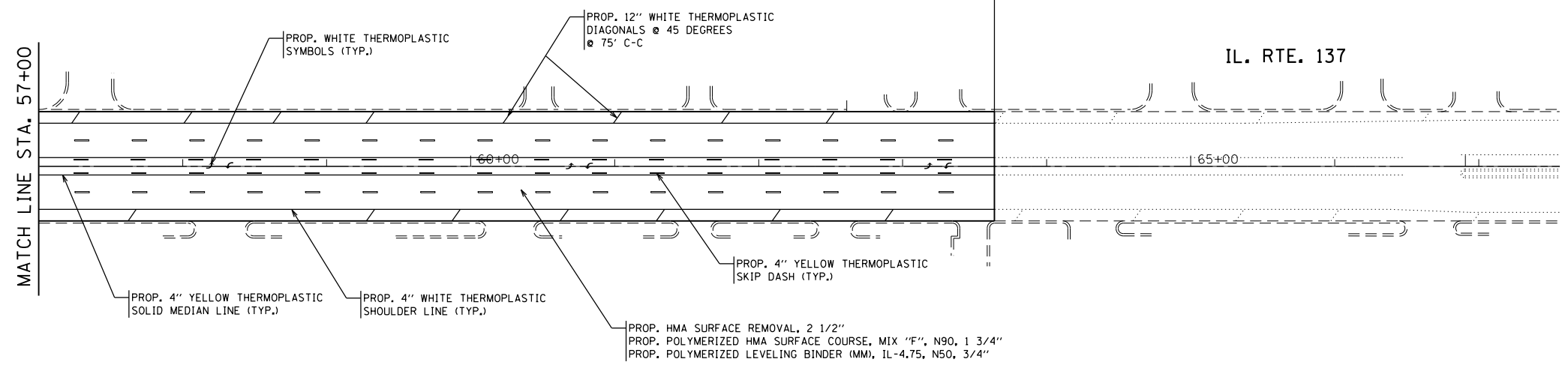

FILE NAME =	USER NAME = phillipsdo	DESIGNED -	REVISED -
et:\pw\work\p1\dot\phillipsdo\d0276648\DI-6511-sht-pln.dgn	6511-sht-pln.dgn	DRAWN -	REVISED -
	PLOT SCALE = 100.0000' / in.	CHECKED -	REVISED -
	PLOT DATE = 6/9/2014	DATE -	REVISED -

**STATE OF ILLINOIS
DEPARTMENT OF TRANSPORTATION**

**IL 137 (BUTTERFIELD RD. TO IL 21 (MILWAUKEE AVE.))
ROADWAY & PAVEMENT MARKINGS PLANS**

SCALE: SHEET 9 OF 24 SHEETS STA. 4+74 TO STA.

F.A.P. RTE.	SECTION	COUNTY	TOTAL SHEETS	SHEET NO.
352	2R-1-RS-1	LAKE	24	9
CONTRACT NO. 60P11				
ILLINOIS FED. AID PROJECT				

WORK SHALL MEET THE REQUIREMENTS OF THE SPECIAL PROVISION, "TRAFFIC SIGNAL SIGNAL SPECIFICATIONS FOR DETECTOR LOOP REPLACEMENT AND/OR INSTALLATION ON ROADWAY GRINDING, RESURFACING AND PATCHING OPERATIONS". SPECIAL ATTENTION MUST BE MADE TO THE SECTIONS "INSPECTION OF CONSTRUCTION" AND "DETECTOR LOOP REPLACEMENT" FOR INSTALLATION AND INSPECTION REQUIREMENTS. LOOP REPLACEMENT WORK THAT DOES NOT MEET THE CONTRACT REQUIREMENTS SHALL NOT BE PAID. WORK NECESSARY TO COMPLETE THE LOOP REPLACEMENT WORK MAY BE ASSIGNED BY THE ENGINEER TO IDOT'S ELECTRICAL MAINTENANCE CONTRACTOR (EMC); ALL RELATED COSTS WILL BE THE RESPONSIBILITY OF THE CONTRACTOR.

TRAFFIC SIGNAL LEGEND

PROPOSED	EXISTING
SIGNAL HEAD WITH BACKPLATE	⇨
SIGNAL HEAD	⇨
GALVANIZED STEEL CONDUIT IN TRENCH OR PUSHED	---
DETECTOR LOOP	□
VEHICLE DETECTOR, NON COMPENSATED MAGNETIC TYPE	⊞
RACEWAY FOR MAGNETIC DETECTOR, TYPE I OR TYPE II	⊞

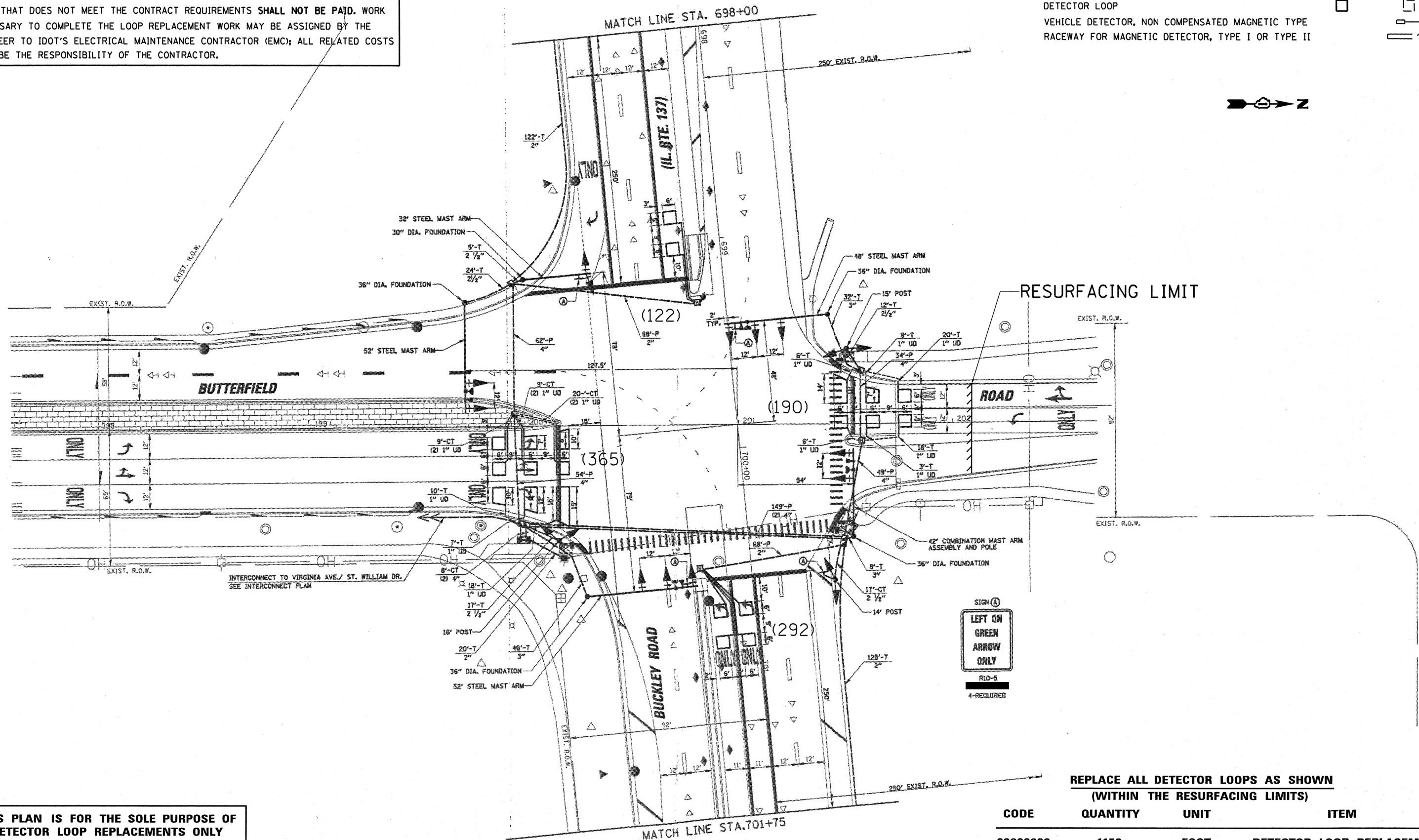
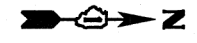

THIS PLAN IS FOR THE SOLE PURPOSE OF DETECTOR LOOP REPLACEMENTS ONLY

REPLACE ALL DETECTOR LOOPS AS SHOWN (WITHIN THE RESURFACING LIMITS)

CODE	QUANTITY	UNIT	ITEM
88600600	1152	FOOT	DETECTOR LOOP REPLACEMENT

FILE NAME =	USER NAME = phillipsdo	DESIGNED -	REVISED -
et:\pwork\pwork\phillipsdo\d0276648\DI	6511-sht-plan.dgn	DRAWN -	REVISED -
	PLOT SCALE = 100.0000' / in.	CHECKED -	REVISED -
	PLOT DATE = 6/9/2014	DATE -	REVISED -

**STATE OF ILLINOIS
DEPARTMENT OF TRANSPORTATION**

**DISTRICT ONE - DETECTOR LOOP REPLACEMENT
IL 137 AT BUTTERFIELD ROAD**

SCALE: SHEET 10 OF 24 SHEETS STA. TO STA.

F.A.P. RTE.	SECTION	COUNTY	TOTAL SHEETS	SHEET NO.
352	2R-1-RS-1	LAKE	24	10
CONTRACT NO. 60P11				
ILLINOIS FED. AID PROJECT				

WORK SHALL MEET THE REQUIREMENTS OF THE SPECIAL PROVISION, "TRAFFIC SIGNAL SPECIFICATIONS FOR DETECTOR LOOP REPLACEMENT AND/OR INSTALLATION ON ROADWAY GRINDING, RESURFACING AND PATCHING OPERATIONS". SPECIAL ATTENTION MUST BE MADE TO THE SECTIONS "INSPECTION OF CONSTRUCTION" AND "DETECTOR LOOP REPLACEMENT" FOR INSTALLATION AND INSPECTION REQUIREMENTS. LOOP REPLACEMENT WORK THAT DOES NOT MEET THE CONTRACT REQUIREMENTS SHALL NOT BE PAID. WORK NECESSARY TO COMPLETE THE LOOP REPLACEMENT WORK MAY BE ASSIGNED BY THE ENGINEER TO IDOT'S ELECTRICAL MAINTENANCE CONTRACTOR (EMC); ALL RELATED COSTS WILL BE THE RESPONSIBILITY OF THE CONTRACTOR.

TRAFFIC SIGNAL LEGEND

	PROPOSED	EXISTING
SIGNAL HEAD WITH BACKPLATE	⬆	⬆
SIGNAL HEAD	⬆	⬆
GALVANIZED STEEL CONDUIT IN TRENCH OR PUSHED	---	---
DETECTOR LOOP	□	□
VEHICLE DETECTOR, NON COMPENSATED MAGNETIC TYPE	—	—
RACEWAY FOR MAGNETIC DETECTOR, TYPE I OR TYPE II	—	— "E"

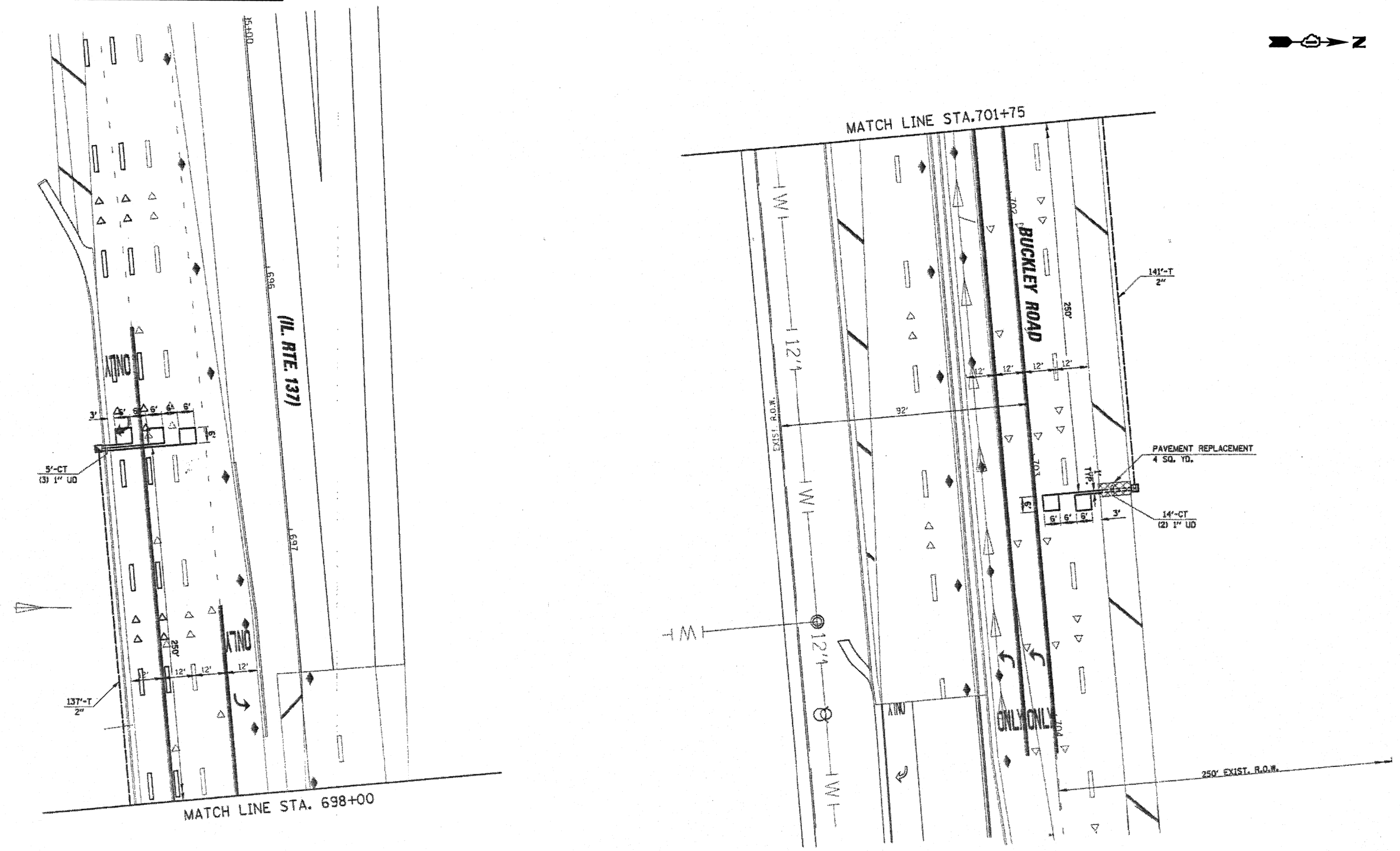

THIS PLAN IS FOR THE SOLE PURPOSE OF DETECTOR LOOP REPLACEMENTS ONLY

REPLACE ALL DETECTOR LOOPS AS SHOWN (WITHIN THE RESURFACING LIMITS)

CODE	QUANTITY	UNIT	ITEM
88600600	1152	FOOT	DETECTOR LOOP REPLACEMENT

FILE NAME =	USER NAME = phillipsdo	DESIGNED -	REVISED -
et:\pw\work\p\idot\phillipsdo\d0276648\DI-6511-sht-plan.dgn		DRAWN -	REVISED -
	PLOT SCALE = 100.0000' / in.	CHECKED -	REVISED -
	PLOT DATE = 6/9/2014	DATE -	REVISED -

**STATE OF ILLINOIS
DEPARTMENT OF TRANSPORTATION**

**DISTRICT ONE - DETECTOR LOOP REPLACEMENT
IL 137 AT BUTTERFIELD ROAD**

SCALE: SHEET 11 OF 24 SHEETS STA. TO STA.

F.A.P. RTE.	SECTION	COUNTY	TOTAL SHEETS	SHEET NO.
352	2R-1-RS-1	LAKE	24	11
			CONTRACT NO. 60P11	
ILLINOIS FED. AID PROJECT				

WORK SHALL MEET THE REQUIREMENTS OF THE SPECIAL PROVISION, "TRAFFIC SIGNAL SPECIFICATIONS FOR DETECTOR LOOP REPLACEMENT AND/OR INSTALLATION ON ROADWAY GRINDING, RESURFACING AND PATCHING OPERATIONS". SPECIAL ATTENTION MUST BE MADE TO THE SECTIONS "INSPECTION OF CONSTRUCTION" AND "DETECTOR LOOP REPLACEMENT" FOR INSTALLATION AND INSPECTION REQUIREMENTS. LOOP REPLACEMENT WORK THAT DOES NOT MEET THE CONTRACT REQUIREMENTS SHALL NOT BE PAID. WORK NECESSARY TO COMPLETE THE LOOP REPLACEMENT WORK MAY BE ASSIGNED BY THE ENGINEER TO IDOT'S ELECTRICAL MAINTENANCE CONTRACTOR (EMC); ALL RELATED COSTS WILL BE THE RESPONSIBILITY OF THE CONTRACTOR.

TRAFFIC SIGNAL LEGEND

	PROPOSED	EXISTING
SIGNAL HEAD WITH BACKPLATE		
SIGNAL HEAD		
GALVANIZED STEEL CONDUIT IN TRENCH OR PUSHED		
DETECTOR LOOP		
VEHICLE DETECTOR, NON COMPENSATED MAGNETIC TYPE		
RACEWAY FOR MAGNETIC DETECTOR, TYPE I OR TYPE II		

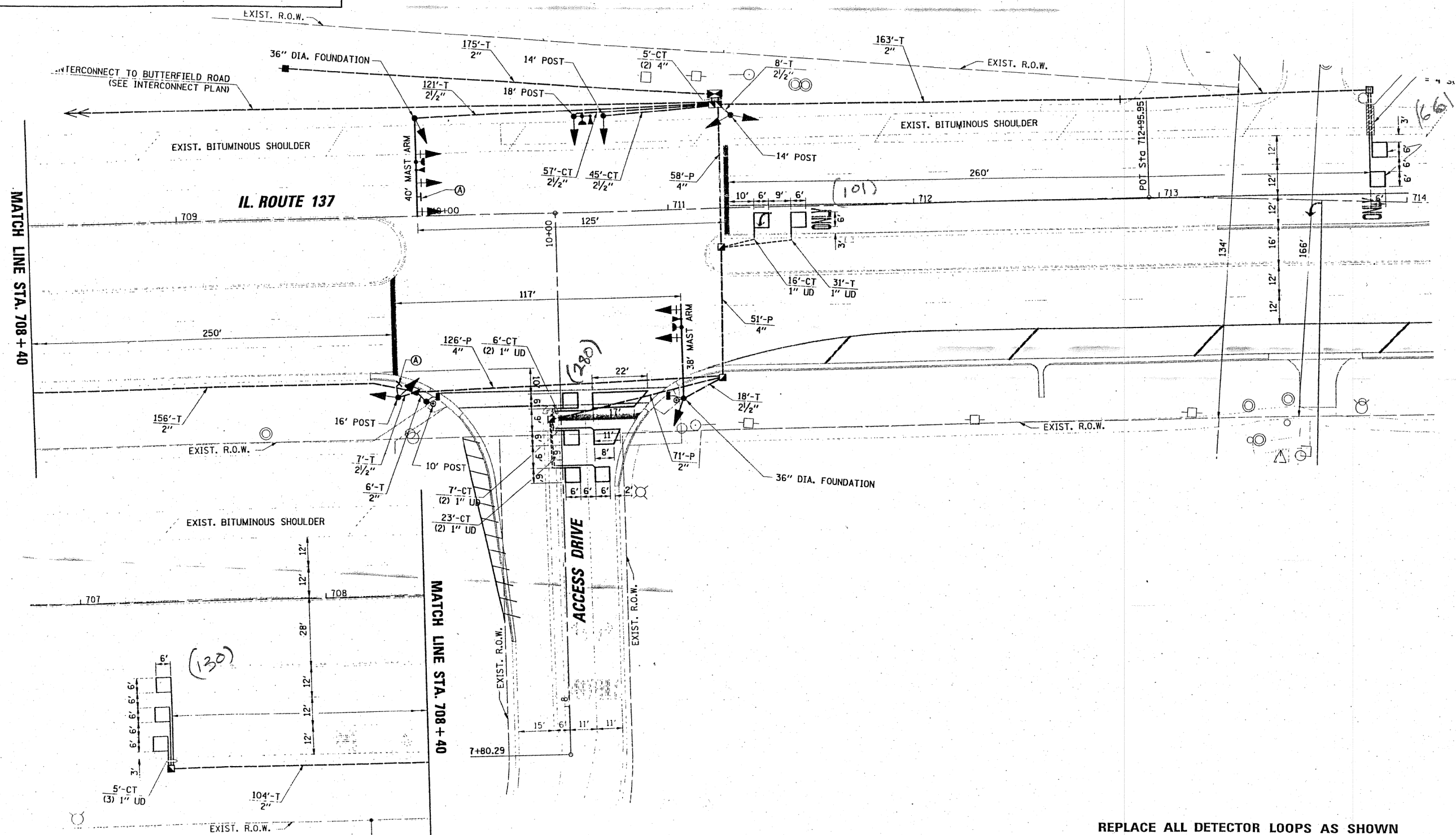

THIS PLAN IS FOR THE SOLE PURPOSE OF DETECTOR LOOP REPLACEMENTS ONLY

REPLACE ALL DETECTOR LOOPS AS SHOWN (WITHIN THE RESURFACING LIMITS)

CODE	QUANTITY	UNIT	ITEM
88600600	577	FOOT	DETECTOR LOOP, REPLACEMENT

FILE NAME =	USER NAME = phillipsdo	DESIGNED -	REVISED -	STATE OF ILLINOIS DEPARTMENT OF TRANSPORTATION	DISTRICT ONE - DETECTOR LOOP REPLACEMENT IL 137 AT BUTTERFIELD SQUARE	F.A.P. RTE.	SECTION	COUNTY	TOTAL SHEETS	SHEET NO.
et:\pwork\pwork\pwork\phillipsdo\0276648\01-6511-sht-plan.dgn	DRAWN -	REVISED -	352			2R-1-RS-1	LAKE	24	12	
PLOT SCALE = 100.0000' / in.	CHECKED -	REVISED -	CONTRACT NO. 60P11							
PLOT DATE = 6/9/2014	DATE -	REVISED -	ILLINOIS FED. AID PROJECT							

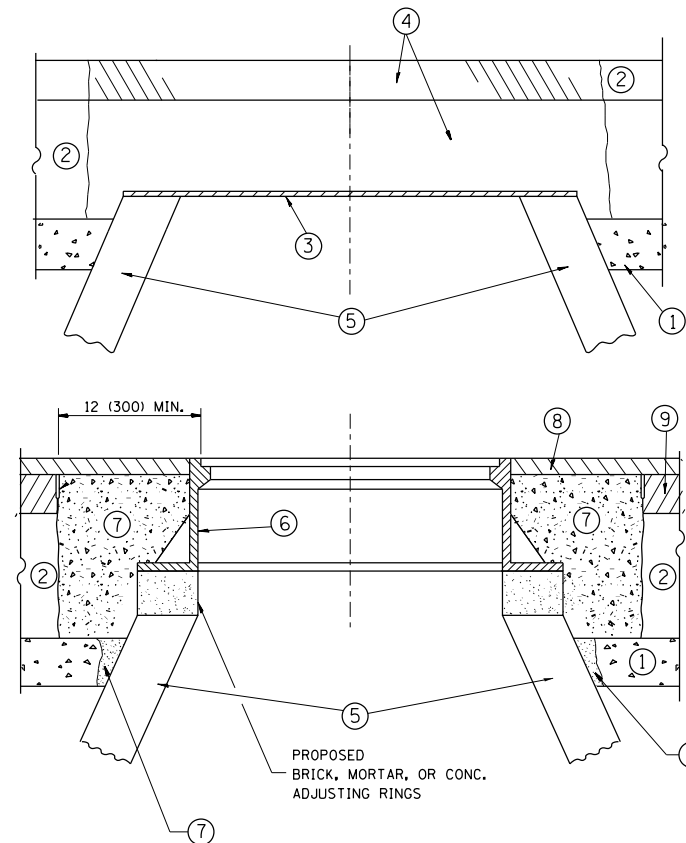

CONSTRUCTION PROCEDURES

STAGE 1 (BEFORE PAVEMENT MILLING)

- A) REMOVE A MINIMUM OF 12 (300) OF THE PAVEMENT FROM AROUND THE STRUCTURE.
- B) REMOVE THE EXISTING FRAME AND LID FROM THE STRUCTURE.
- C) COVER THE STRUCTURE OPENING WITH A 36 (900) DIAMETER METAL PLATE.
- D) BACKFILL WITH CRUSHED STONE AND A MINIMUM 1/2 (40) THICK HMA SURFACE MIX APPROVED BY THE ENGINEER.

STAGE 2 (AFTER PAVEMENT MILLING)

- A) REMOVE THE HMA SURFACE MIX AND CRUSHED STONE.
- B) INSTALL THE FRAME AND LID; ADJUST THE FRAME TO ITS FINAL SURFACE ELEVATION.
- C) THE SURROUNDING SPACE SHALL BE FILLED WITH CLASS PP-1* CONCRETE TO THE ELEVATION OF THE SURFACE OF THE EXISTING BASE COURSE OR THE BINDER COURSE.

* UNLESS OTHERWISE SPECIFIED IN THE PLANS.

THE PROCEDURE EXPLAINED ABOVE SHALL CONFORM TO THE APPLICABLE PORTIONS OF SECTIONS 353, 406, 602, AND 603 OF THE STANDARD SPECIFICATIONS EXCEPT THAT "THE CONTRACTOR SHALL ADJUST THE STRUCTURES TO THE FINISHED PAVEMENT ELEVATION NO MORE THAN 5 CALENDAR DAYS PRIOR TO PLACEMENT OF THE FINAL LIFT OF SURFACE UNLESS APPROVED BY THE ENGINEER."

LEGEND

- ① SUB-BASE GRANULAR MATERIAL
- ② EXISTING PAVEMENT
- ③ 36 (900) DIAMETER METAL PLATE
- ④ PROPOSED CRUSHED STONE AND HMA SURFACE MIX
- ⑤ EXISTING STRUCTURE
- ⑥ FRAME AND LID (SEE NOTES)
- ⑦ CLASS PP-1* CONCRETE
- ⑧ PROPOSED HMA SURFACE COURSE
- ⑨ PROPOSED HMA BINDER COURSE

LOCATION OF STRUCTURES:

THE CONTRACTOR WILL BE REQUIRED TO KEEP A RECORD OF THE LOCATIONS OF THE BURIED STRUCTURES ACCORDING TO THE STATION AND DISTANCE LEFT OR RIGHT OF THE CENTERLINE OF PAVEMENT. UPON COMPLETION OF THE WORK, THE CONTRACTOR WILL DELIVER THE RECORD TO THE ENGINEER.

BASIS OF PAYMENT:

REMOVING FRAMES AND LIDS ON DRAINAGE AND UTILITY STRUCTURES IN THE PAVEMENT PRIOR TO MILLING, AND ADJUSTING TO FINAL GRADE PRIOR TO PLACING THE SURFACE COURSE, WILL BE PAID FOR AT THE CONTRACT UNIT PRICE EACH FOR "FRAMES AND LIDS TO BE ADJUSTED (SPECIAL)."

THIS WORK WILL NOT BE PAID FOR WHEN DRAINAGE AND UTILITY STRUCTURES ARE SPECIFIED FOR PAYMENT AS STRUCTURE RECONSTRUCTION.

NEW FRAMES AND LIDS, WHEN SPECIFIED, WILL BE PAID FOR SEPARATELY.

NOTES:

EXISTING BROKEN FRAMES AND LIDS SHALL BE REMOVED AND DISPOSED OF BY THE CONTRACTOR AND SHALL BE REPLACED AS DIRECTED BY THE ENGINEER. REPLACEMENT FRAMES AND LIDS WILL BE PAID FOR IN ACCORDANCE WITH ARTICLE 109.04 OF THE STANDARD SPECIFICATIONS UNLESS A SEPARATE PAY ITEM HAS BEEN PROVIDED.

IF THE EXISTING LIDS ARE OPEN, THE FRAME WILL BE ADJUSTED TO THE ELEVATION OF THE MILLED PAVEMENT SURFACE PRIOR TO THE MILLING OPERATION. THE FRAME WILL NOT BE REMOVED AND COVERED BY THE METAL PLATE.

CITY OF CHICAGO CASTINGS ARE THE PROPERTY OF THE CITY AND THE CONTRACTOR SHALL NOTIFY THE CITY FOR REMOVAL AND DISPOSITION OF THE CASTINGS.

THE METAL PLATE USED TO COVER THE STRUCTURE SHALL REMAIN THE PROPERTY OF THE CONTRACTOR.

WHEN STRUCTURES ARE TO BE ADJUSTED OR RECONSTRUCTED, THE LOWERING AND RAISING OF THE FRAMES AND LIDS WILL NOT BE PAID FOR SEPARATELY BUT WILL BE INCLUDED IN THE COST OF THE CORRESPONDING PAY ITEM.

DETAILS FOR FRAMES AND LIDS ADJUSTMENT WITH MILLING

ALL DIMENSIONS ARE IN INCHES (MILLIMETERS) UNLESS OTHERWISE SHOWN

FILE NAME =	USER NAME = phillipsdo	DESIGNED - R. SHAH	REVISED - R. WIEDEMAN 05-14-04
et:\pwork\pwork\phillipsdo\d0276648\Std.dgn		DRAWN -	REVISED - R. BORO 01-01-07
	PLOT SCALE = 100.0000' / in.	CHECKED -	REVISED - R. BORO 03-09-11
	PLOT DATE = 6/9/2014	DATE - 10-25-94	REVISED - R. BORO 12-06-11

**STATE OF ILLINOIS
DEPARTMENT OF TRANSPORTATION**

DETAILS FOR FRAMES AND LIDS ADJUSTMENT WITH MILLING			
SCALE: NONE	SHEET NO. 1 OF 1 SHEETS	STA.	TO STA.

F.A.P. RTE.	SECTION	COUNTY	TOTAL SHEETS	SHEET NO.
352	2R-1-RS-1	LAKE	24	13
BD600-03 (BD-8)		CONTRACT NO.	60P11	
<small>FED. ROAD DIST. NO. 1 ILLINOIS FED. AID PROJECT</small>				

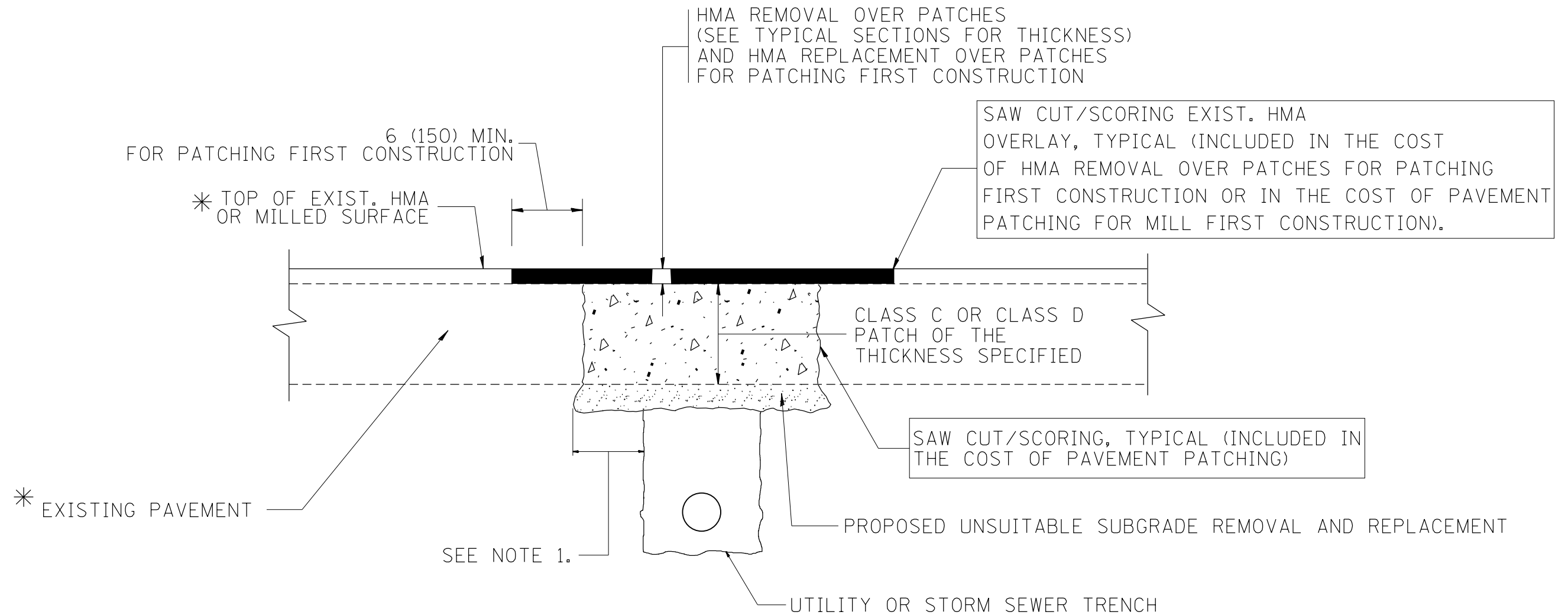

* SEE TYPICAL SECTIONS FOR THICKNESS AND MATERIALS

NOTES:

1. THE WIDTH OF THE FULL DEPTH PATCH OVER A TRENCH SHALL BE 12 (300) WIDER ON EACH SIDE OF THE TRENCH.
2. FOR METHOD OF MEASUREMENT AND BASIS OF PAYMENT, SEE RECURRING SPECIAL PROVISION "PATCHING WITH HOT-MIX ASPHALT OVERLAY REMOVAL".

SEQUENCE OF CONSTRUCTION (PATCHING FIRST)

1. REMOVE THE EXISTING HMA MATERIAL OVER THE AREA TO BE PATCHED.
2. REMOVE AND REPLACE WITH CLASS C OR D PATCH.
3. REPLACE HMA MATERIAL OVER THE AREA TO BE PATCHED.

SEQUENCE OF CONSTRUCTION (MILLING FIRST)

1. MILL HMA FIRST IF THERE IS AT LEAST 4 1/2 INCHES OR MORE OF HMA MATERIAL ON TOP OF THE EXISTING PAVEMENT OR IF THE PAVEMENT IS FULL DEPTH HMA. A MINIMUM OF 2 INCHES OF HMA MATERIAL SHALL BE IN PLACE AFTER MILLING.
2. REMOVE AND REPLACE WITH FULL DEPTH CLASS D PATCHES TO TOP OF MILLED SURFACE.

ALL DIMENSIONS ARE IN INCHES (MILLIMETERS) UNLESS OTHERWISE SHOWN.

FILE NAME =	USER NAME = phillipsdo	DESIGNED - R. SHAH	REVISED - A. ABBAS 04-27-98	STATE OF ILLINOIS DEPARTMENT OF TRANSPORTATION	PAVEMENT PATCHING FOR HMA SURFACED PAVEMENT			F.A.P. RTE.	SECTION	COUNTY	TOTAL SHEETS	SHEET NO.
et:\pwork\pwork\phillipsdo\d0276648\Std.dgn	DRAWN -	REVISED - R. BORO 01-01-07	REVISED - R. BORO 09-04-07					352	2R-1-RS-1	LAKE	24	14
	PLOT SCALE = 100.0000' / in.	CHECKED -	REVISED - K. ENG 10-27-08		BD400-04 (BD-22)			CONTRACT NO. 60P11				
	PLOT DATE = 6/9/2014	DATE - 10-25-94			SCALE: NONE	SHEET NO. 1 OF 1 SHEETS	STA. TO STA.	FED. ROAD DIST. NO. 1 ILLINOIS FED. AID PROJECT				

VARIABLE - TO MEET EXISTING DIMENSIONS AND FIELD CONDITIONS (SEE NOTE ②)

PROP. CONC. CURB OR CURB AND GUTTER REPLACEMENT IN ACCORDANCE WITH STATE STANDARD 606001. (SEE NOTE ②)

SAW CUT FULL DEPTH - INCLUDED IN THE COST OF SIDEWALK, DRIVEWAY OR MEDIAN SURFACE REMOVAL PAY ITEM.

SEE STATE STANDARD 606001
EXISTING OR PROPOSED HMA SURFACE (IF APPLICABLE)

18" (450) MAX.

1/4" (5) **

EXISTING SIDEWALK, DRIVEWAY, MEDIAN SURFACE, SOD OR GROUND.

PROPOSED SIDEWALK, DRIVEWAY PAVEMENT, MEDIAN SURFACE OR SODDING SALT TOLERANT WITH TOP SOIL, 4" (100) SOD RESTORATION (SEE NOTE ①).

EXISTING CONCRETE PAVEMENT, CONCRETE BASE COURSE OR FLEXIBLE PAVEMENT

3" (75) MIN.

SUITABLE BACKFILL MATERIAL (INCLUDED IN THE COST OF CURB OR CURB AND GUTTER REMOVAL AND REPLACEMENT)

PROPOSED 3/4" (20) PREFORMED EXPANSION JOINT AT CONCRETE SIDEWALKS, DRIVEWAYS, AND MEDIANS. (INCLUDED IN THE COST OF CURB OR CURB AND GUTTER REMOVAL AND REPLACEMENT.)

* 3" (75) MINIMUM FROM TOP AND BOTTOM OF THE CONCRETE PAVEMENT OR BASE COURSE.

** IF THE FINAL SURFACE OF THE PAVEMENT IS CONCRETE, THE GUTTER IS TO BE FLUSH WITH THE PAVEMENT.

NOTE: ① SIDEWALK, DRIVEWAY PAVEMENT OR MEDIAN SURFACE SHALL BE SIMILAR TO THE MATERIAL BEING REMOVED AND WILL BE PAID FOR SEPARATELY.

SODDING, SALT TOLERANT AND TOP SOIL, FURNISH AND PLACE 4" WILL BE PAID FOR SEPARATELY.

② FERTILIZER FOR THE PLACEMENT OF THE SOD IS NOT REQUIRED

③ CURB OR CURB AND GUTTER REPLACEMENT SHALL MATCH THE SHAPE OF THE EXISTING CURB OR CURB AND GUTTER UNLESS OTHERWISE SPECIFIED.

④ FOR CURB OR CURB AND GUTTER REMOVAL AND REPLACEMENT ADJACENT TO FLEXIBLE PAVEMENT DELETE EPOXY COATED TIE BARS.

⑤ LONGITUDINAL BARS, IF ENCOUNTERED IN THE EXISTING CURB OR CURB AND GUTTER, ARE NOT TO BE REPLACED. CUTTING AND REMOVING LONGITUDINAL BARS SHALL BE INCLUDED IN THE COST OF CURB OR CURB AND GUTTER REMOVAL AND REPLACEMENT.

⑥ THE COST OF HMA SURFACE REMOVAL IN THE EXISTING GUTTER FLAG SHALL BE INCLUDED IN THE COST OF THE CURB AND GUTTER REMOVAL AND REPLACEMENT.

⑦ THE REMOVAL AND REPLACEMENT OF THE EXISTING CURB OR CURB AND GUTTER SHALL BE DONE IN ACCORDANCE WITH THE APPLICABLE PORTIONS OF SECTION 440 AND 606 OF THE STANDARD SPECIFICATIONS.

⑧ THE LOCATIONS OF REMOVAL AND REPLACEMENT OF EXISTING CURB OR CURB AND GUTTER SHALL BE DETERMINED BY THE RESIDENT ENGINEER AT THE TIME OF CONSTRUCTION.

UNSUITABLE SUB-BASE MATERIAL TO BE REMOVED, IF DIRECTED BY THE ENGINEER, SHALL BE REPLACED WITH EITHER SUB-BASE GRANULAR MATERIAL, TYPE B OR ADDITIONAL THICKNESS OF CONCRETE.

REMOVAL AND REPLACEMENT 4" (100) OR LESS IS INCLUDED IN THE COST OF CURB OR CURB AND GUTTER REMOVAL AND REPLACEMENT.

REMOVAL AND REPLACEMENT IN EXCESS OF 4" (100) WILL BE PAID FOR IN ACCORDANCE WITH ARTICLE 109.04 OF THE STANDARD SPECIFICATIONS.

PROPOSED #6 (20) EPOXY COATED TIE BARS 24" (600) LONG AT 24" (600) CENTERS WILL NOT BE PAID FOR SEPARATELY. DELETE EPOXY COATED TIE BARS IF EXISTING TIE BARS ARE USABLE AS DETERMINED BY THE ENGINEER. (SEE NOTE ③).

BASIS OF PAYMENT:
THIS WORK WILL BE PAID FOR AT THE CONTRACT UNIT PRICE PER FOOT (METER) FOR "CURB REMOVAL AND REPLACEMENT" OR "COMBINATION CONCRETE CURB AND GUTTER REMOVAL AND REPLACEMENT".

CURB OR CURB AND GUTTER REMOVAL AND REPLACEMENT

ALL DIMENSIONS ARE IN INCHES (MILLIMETERS) UNLESS OTHERWISE SHOWN.

FILE NAME =	USER NAME = philipsdo	DESIGNED - A. HOUSEH	REVISED - R. SHAH 10-03-96	STATE OF ILLINOIS DEPARTMENT OF TRANSPORTATION	CURB OR CURB AND GUTTER REMOVAL AND REPLACEMENT	F.A.P. RTE.	SECTION	COUNTY	TOTAL SHEETS	SHEET NO.
et:\pw\work\p\dot\philipsdo\d0276648\Di	Std.dgn	DRAWN -	REVISED - A. ABBAS 03-21-97			352	2R-1-RS-1	LAKE	24	15
	PLOT SCALE = 100.0000' / in.	CHECKED -	REVISED - M. GOMEZ 01-22-01			BD600-06 (BD-24)		CONTRACT NO. 60P11		
	PLOT DATE = 6/9/2014	DATE - 03-11-94	REVISED - R. BORO 12-15-09			SCALE: NONE	SHEET NO. 1 OF 1 SHEETS	STA.	TO STA.	FED. ROAD DIST. NO. 1 ILLINOIS FED. AID PROJECT

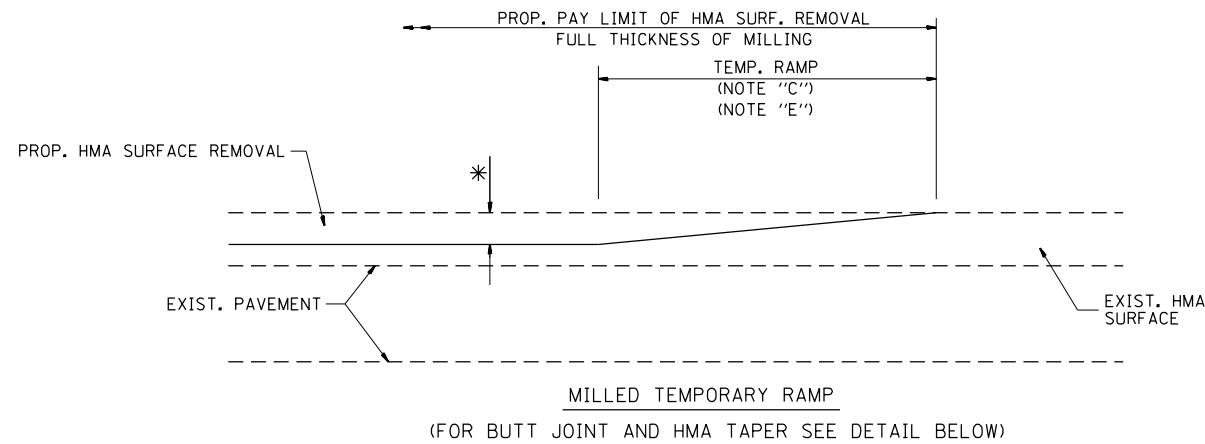

OPTION 1

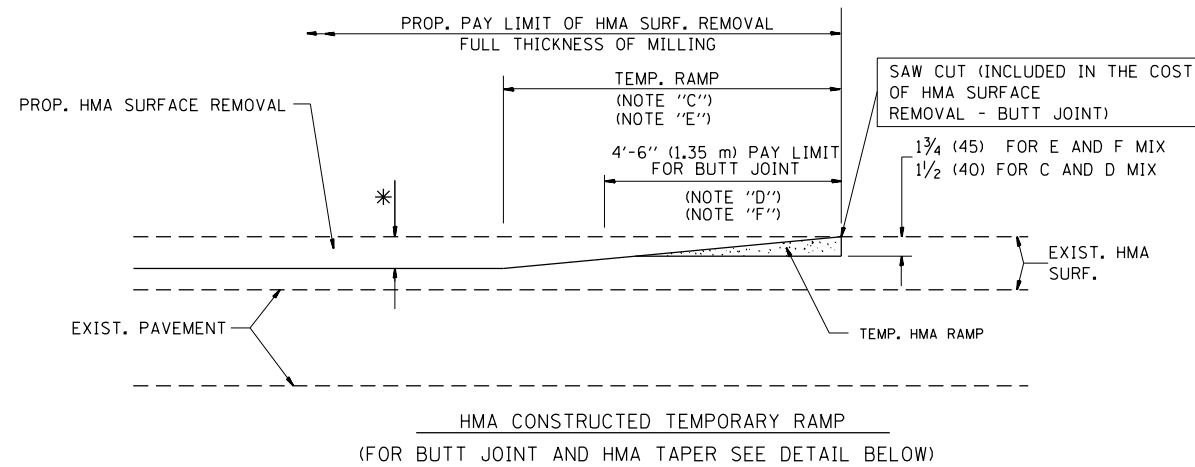

OPTION 2

TYPICAL TEMPORARY RAMP

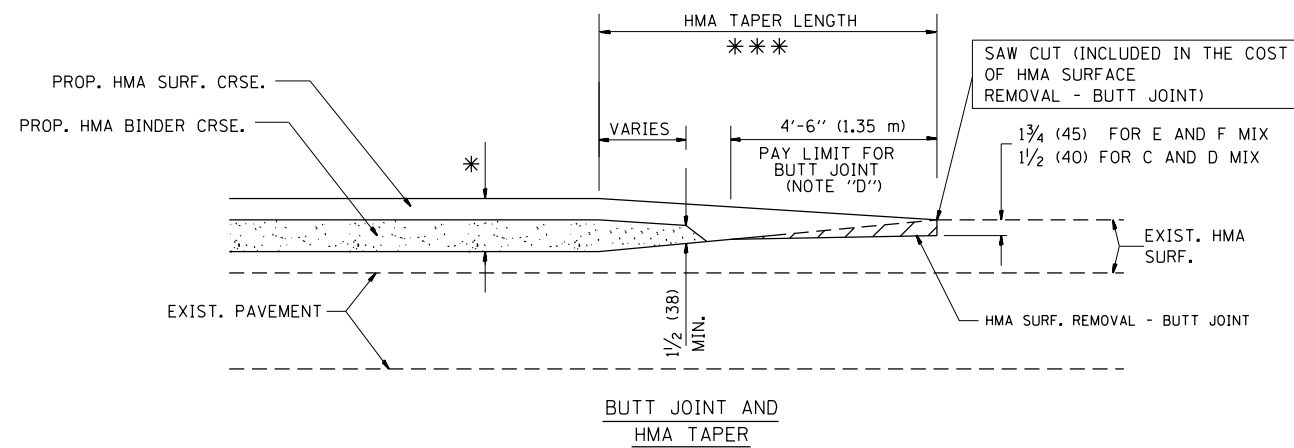

TYPICAL BUTT JOINT AND HMA TAPER FOR MILLING AND RESURFACING

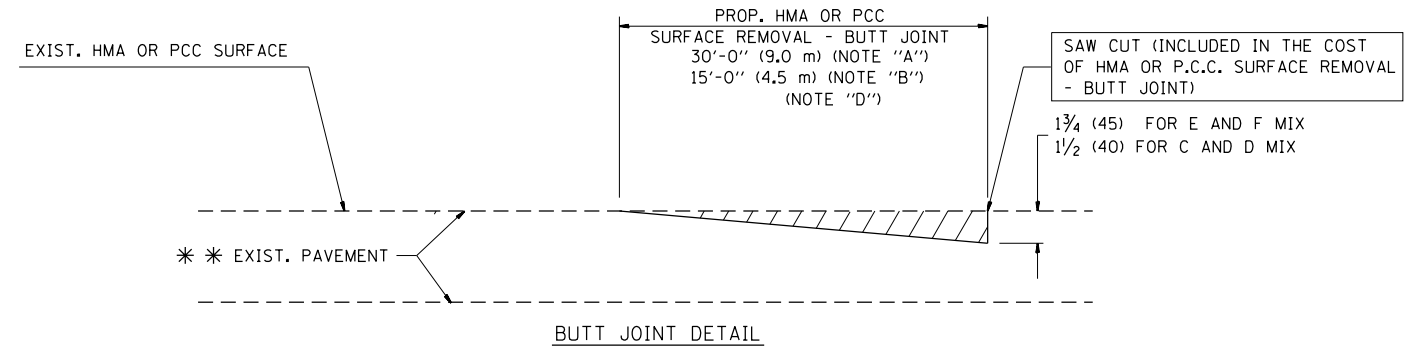

BUTT JOINT DETAIL

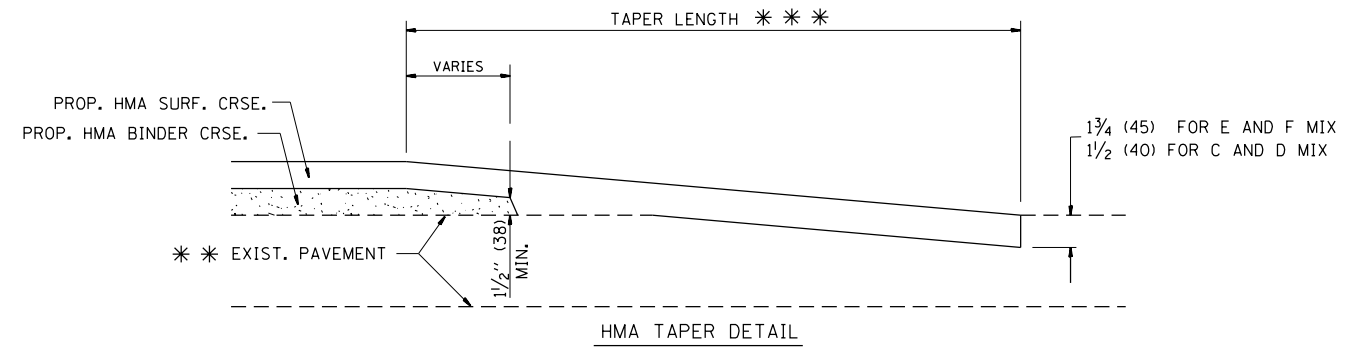

HMA TAPER DETAIL

TYPICAL BUTT JOINT AND HMA TAPER FOR RESURFACING ONLY

*** PC CONCRETE, HMA OR HMA RESURFACED PAVEMENT.

NOTES

- A: MAINLINE ROADWAYS AND MAJOR SIDE ROADS.
- B: MINOR SIDE ROADS.
- C: THE TEMP. RAMP SHALL BE CONSTRUCTED IMMEDIATELY UPON REMOVAL OF THE EXISTING HMA SURFACE.
- D: THE BUTT JOINT SHALL BE CONSTRUCTED IMMEDIATELY PRIOR TO PLACING THE PROPOSED HMA COURSES.
- E: TAPER THE TEMP. RAMP AT A RATE OF 3'-0" (900 mm) PER 1 INCH (25 mm) OF MILLING THICKNESS.
- F: INSTALLATION AND REMOVAL OF THE 4'-6" (1.35 m) TEMP. RAMP IS INCLUDED IN COST OF HMA SURFACE REMOVAL - BUTT JOINT
- G: SEE ARTICLE 406.08 AND 406.14 OF THE STANDARD SPECIFICATIONS FOR "HMA AND/OR PCC SURFACE REMOVAL, BUTT JOINT".

* SEE TYPICAL SECTIONS FOR MILLING THICKNESS.

*** 20'-0" (6.1 m) PER 1 (25) RESURFACING (NOTE "A")
10'-0" (3.0 m) PER 1 (25) RESURFACING (NOTE "B")

BASIS OF PAYMENT:

THE BUTT JOINT WILL BE PAID FOR AT THE CONTRACT UNIT PRICE PER SQUARE YARD (SQUARE METER) FOR "HOT-MIX ASPHALT SURFACE REMOVAL - BUTT JOINT" OR FOR "PORTLAND CEMENT CONCRETE SURFACE REMOVAL - BUTT JOINT".

ALL DIMENSIONS ARE IN INCHES (MILLIMETERS) UNLESS OTHERWISE SHOWN.

FILE NAME =	USER NAME = philipsdo	DESIGNED - M. DE YONG	REVISED - R. SHAH 10-25-94
et:\pw\work\p\dot\philipsdo\d0276648\Std.dgn		DRAWN -	REVISED - A. ABBAS 03-21-97
	PLOT SCALE = 100.0000' / in.	CHECKED -	REVISED - M. GOMEZ 04-06-01
	PLOT DATE = 6/9/2014	DATE - 06-13-90	REVISED - R. BORO 01-01-07

**STATE OF ILLINOIS
DEPARTMENT OF TRANSPORTATION**

**BUTT JOINT AND
HMA TAPER DETAILS**

SCALE: NONE SHEET NO. 1 OF 1 SHEETS STA. TO STA.

F.A.P. RTE.	SECTION	COUNTY	TOTAL SHEETS	SHEET NO.
352	2R-1-RS-1	LAKE	24	16
BD400-05 BD32		CONTRACT NO. 60P11		
FED. ROAD DIST. NO. 1 ILLINOIS FED. AID PROJECT				



TRAFFIC CONTROL AND PROTECTION FOR SIDE ROADS, INTERSECTIONS, AND DRIVEWAYS

NOTES:

A. FOR NO LANE RESTRICTION ON THE SIDE ROAD OR DRIVEWAYS

1. SIDE ROAD WITH A SPEED LIMIT OF 40 MPH (60 km/h) OR LESS AS SHOWN ON THE DRAWING AND AS DIRECTED BY THE ENGINEER:
 - a) ONE ROAD CONSTRUCTION AHEAD SIGN 36 x 36 (900x900) WITH A FLASHER AND FLAG MOUNTED ON IT APPROXIMATELY 200' (60 m) IN ADVANCE OF THE MAIN ROUTE.
 - b) THE CLOSED PORTION OF THE MAIN ROUTE SHALL BE PROTECTED BY BLOCKING WITH TYPE I, TYPE II OR TYPE III BARRICADES, 1/3 OF THE CROSS SECTION OF THE CLOSED PORTION.
2. SIDE ROAD WITH A SPEED LIMIT GREATER THAN 40 MPH (60 km/h) AS SHOWN ON THE DRAWING AND AS DIRECTED BY THE ENGINEER:
 - a) ONE ROAD CONSTRUCTION AHEAD SIGN 48 x 48 (1.2 m x 1.2 m) WITH A FLASHER MOUNTED ON IT APPROXIMATELY 500' (150 m) IN ADVANCE OF THE MAIN ROUTE.
 - b) THE CLOSED PORTION OF THE MAIN ROUTE SHALL BE PROTECTED BY BLOCKING WITH TYPE III BARRICADES, 1/2 OF THE CROSS SECTION OF THE CLOSED PORTION.
3. WHEN THE SIDE ROAD LIES BETWEEN THE BEGINNING OF THE MAINLINE SIGNING AND THE WORK ZONE, A SINGLE HEADED ARROW (M6-1) SHALL BE USED IN LIEU OF THE DOUBLE HEADED ARROW (M6-4).

B. FOR A LANE CLOSURE ON A SIDE ROAD OR DRIVEWAY:

- USE APPLICABLE PORTIONS OF THE TYPICAL APPLICATION OF TRAFFIC CONTROL DEVICES (STD. 701501, STD. 701606 OR THE APPROPRIATE STANDARD). THE SPACING OF SIGNS AND BARRICADES SHALL BE ADJUSTED FOR FIELD CONDITIONS AS DIRECTED BY THE ENGINEER. THE DIRECTIONAL ARROW SHALL BE COVERED OR REMOVED WHEN NO LONGER CONSISTENT WITH THE SIDE ROAD LANE CLOSURE.
- C. ADVANCE WARNING SIGNS ARE TO BE OMITTED ON DRIVEWAY UNLESS OTHERWISE NOTED.
- D. THE TRAFFIC CONTROL AND PROTECTION FOR SIDE ROADS, INTERSECTIONS, AND DRIVEWAYS SHALL BE INCIDENTAL TO THE COST OF SPECIFIED TRAFFIC CONTROL STANDARDS OR ITEMS.

All dimensions are in millimeters (inches) unless otherwise shown.

FILE NAME =	USER NAME = philipsdo	DESIGNED - LHA	REVISED - J. OBERLE 10-18-95
et:\pwork\pwork\philipsdo\d0276648\Std.dgn		DRAWN -	REVISED - A. HOUSEH 03-06-96
	PLOT SCALE = 100.0000' / in.	CHECKED -	REVISED - A. HOUSEH 10-15-96
	PLOT DATE = 6/9/2014	DATE - 06-89	REVISED - T. RAMMACH 01-06-00

STATE OF ILLINOIS
DEPARTMENT OF TRANSPORTATION

TRAFFIC CONTROL AND PROTECTION FOR
SIDE ROADS, INTERSECTIONS, AND DRIVEWAYS

SCALE: NONE SHEET NO. 1 OF 1 SHEETS STA. TO STA.

F.A.P. RTE.	SECTION	COUNTY	TOTAL SHEETS	SHEET NO.
352	2R-1-RS-1	LAKE	24	17
TC-10			CONTRACT NO. 60P11	
FED. ROAD DIST. NO. 1 ILLINOIS FED. AID PROJECT				

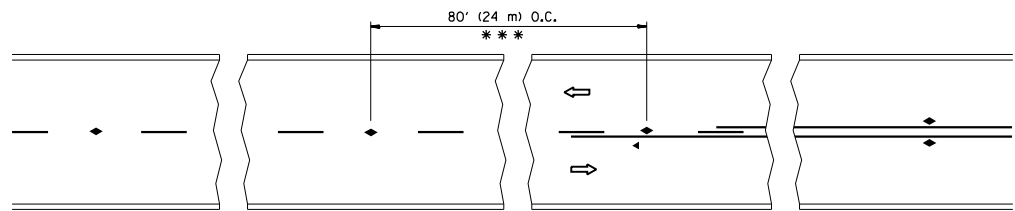

*** REDUCE TO 40' (12 m) O.C. ON CURVES WITH POSTED OR ADVISORY SPEED 45 M.P.H. (70 km/h) OR LESS.

TWO-LANE/TWO-WAY

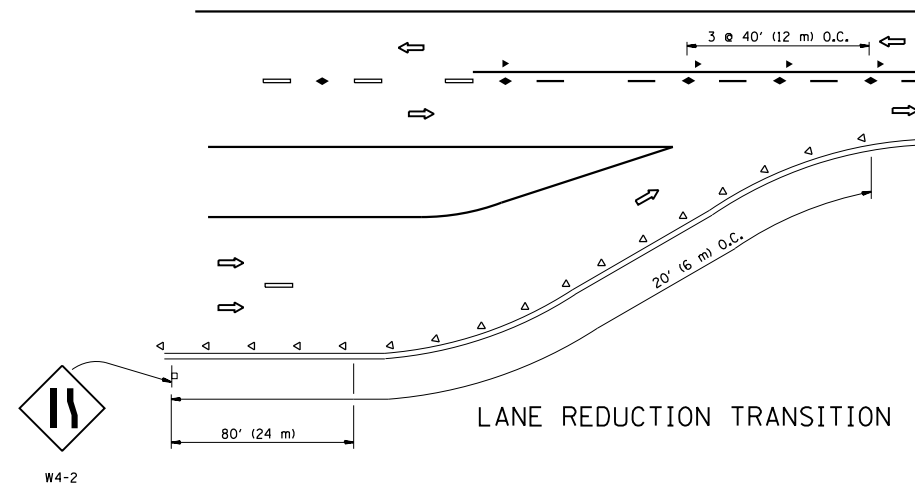

LANE REDUCTION TRANSITION

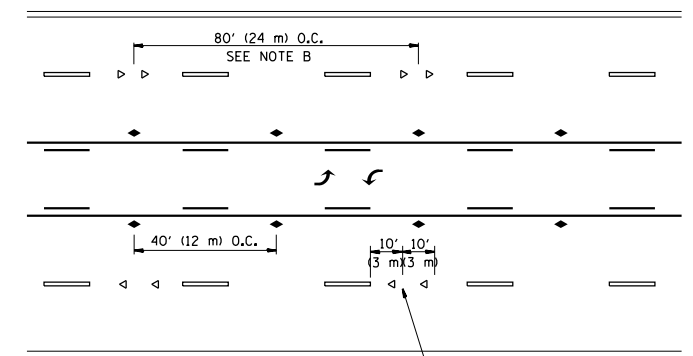

TWO-WAY LEFT TURN

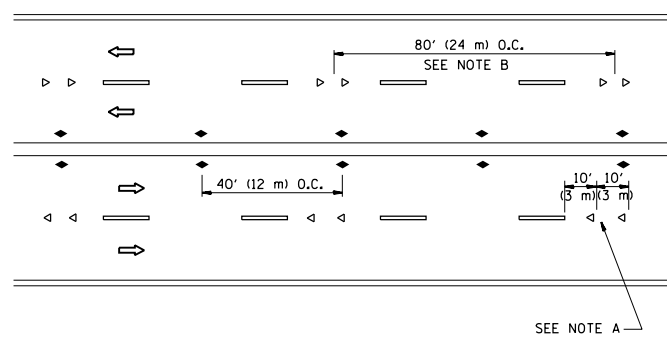

MULTI-LANE/UNDIVIDED

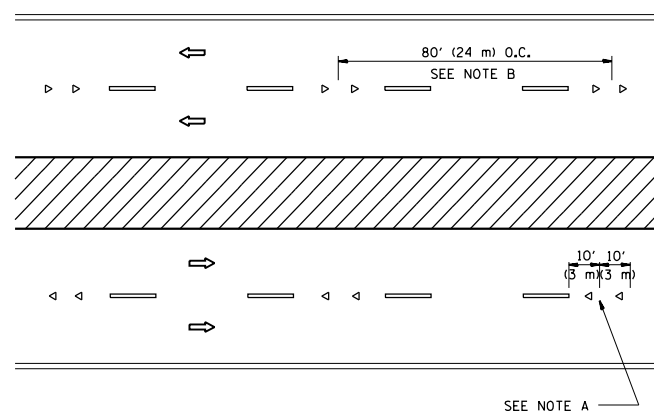

MULTI-LANE/DIVIDED

GENERAL NOTES

1. MARKERS USED WITH DASHED LINES SHALL BE CENTERED IN THE GAP BETWEEN SEGMENTS.
2. MARKERS USED ADJACENT TO SOLID LINES SHALL BE OFFSET 2 TO 3 (50 TO 75) TOWARD TRAFFIC AS SHOWN.
3. MARKERS THROUGH TANGENTS LESS THAN 500' (150 m) IN LENGTH BETWEEN CURVES SHALL BE INSTALLED AT THE LESSER OF THE TWO CURVE SPACINGS.

SYMBOLS

- YELLOW STRIPE
- WHITE STRIPE
- ◀ ONE-WAY AMBER MARKER
- ◁ ONE-WAY CRYSTAL MARKER (W/O)
- ◆ TWO-WAY AMBER MARKER

LANE MARKER NOTES

- A. USE DOUBLE LANE LINE MARKERS SPACED AS SHOWN.
- B. REDUCE TO 40' (12 m) O.C. ON CURVES WHERE ADVISORY SPEEDS ARE 10 M.P.H (20 km/h) LOWER THAN POSTED SPEEDS.

DESIGN NOTES

1. DOUBLE LANE LINE MARKERS SHALL BE USED UNLESS SPECIFIED OTHERWISE.
2. EXCEPT AS SHOWN ON THE LANE REDUCTION TRANSITION AND FREEWAY EXIT RAMP DETAIL, MARKERS ARE NOT TO BE SPECIFIED ON RIGHT EDGE LINES.
3. THE EXACT MARKER LIMITS, SPACING, AND COLOR SHALL BE INCLUDED IN THE PLANS WHEN STANDARD SPECIFICATIONS ARE NOT BEING USED.
4. MARKERS SHOULD NOT BE USED ALONGSIDE CURBS EXCEPT FOR EXTREMELY SHORT SECTIONS OF CURBS WHERE NOT MORE THAN TWO MARKERS WOULD BE INVOLVED.

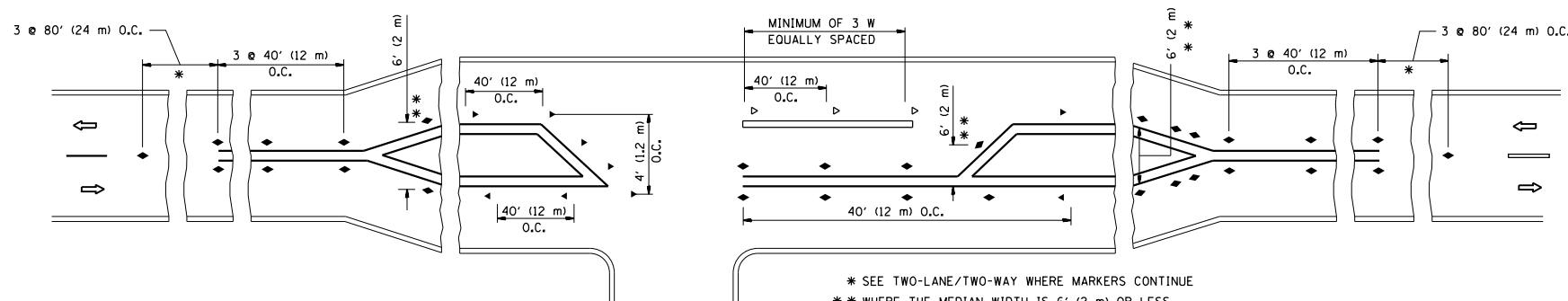

LEFT TURN

* SEE TWO-LANE/TWO-WAY WHERE MARKERS CONTINUE
 ** WHERE THE MEDIAN WIDTH IS 6' (2 m) OR LESS USE TWO-WAY MARKERS.

All dimensions are in inches (millimeters) unless otherwise shown.

FILE NAME =	USER NAME = philippsdo	DESIGNED -	REVISED - T. RAMMACHER 09-19-94
et:\pw\work\p\dot\philippsdo\d0276648\Std.dgn		DRAWN -	REVISED - T. RAMMACHER 03-12-99
	PLOT SCALE = 100.0000' / in.	CHECKED -	REVISED - T. RAMMACHER 01-06-00
	PLOT DATE = 6/9/2014	DATE -	REVISED - C. JUCIUS 09-09-09

STATE OF ILLINOIS
 DEPARTMENT OF TRANSPORTATION

TYPICAL APPLICATIONS			
RAISED REFLECTIVE PAVEMENT MARKERS (SNOW-PLOW RESISTANT)			
SCALE: NONE	SHEET NO. 1 OF 1 SHEETS	STA.	TO STA.

F.A.P. RTE.	SECTION	COUNTY	TOTAL SHEETS	SHEET NO.
352	2R-1-RS-1	LAKE	24	18
TC-11		CONTRACT NO. 60P11		
FED. ROAD DIST. NO. 1 ILLINOIS FED. AID PROJECT				

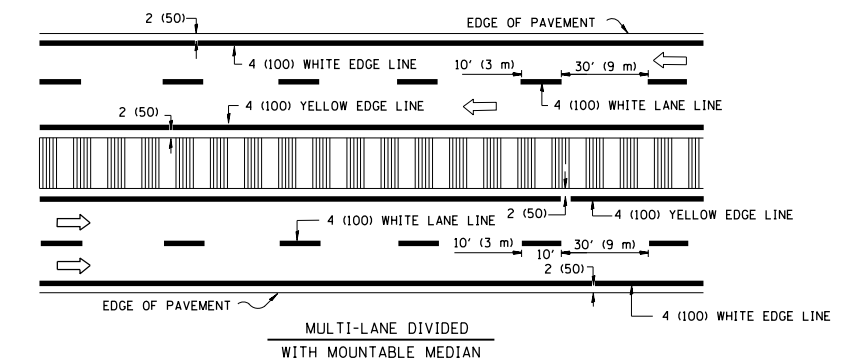
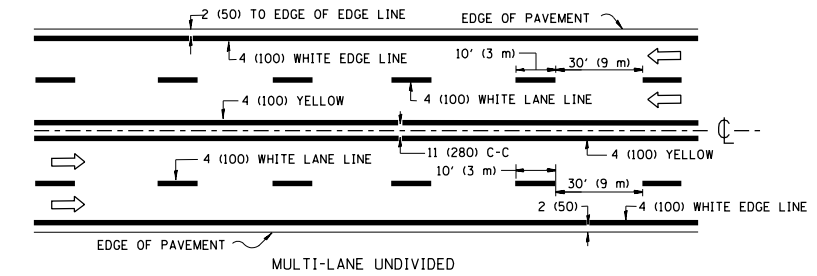
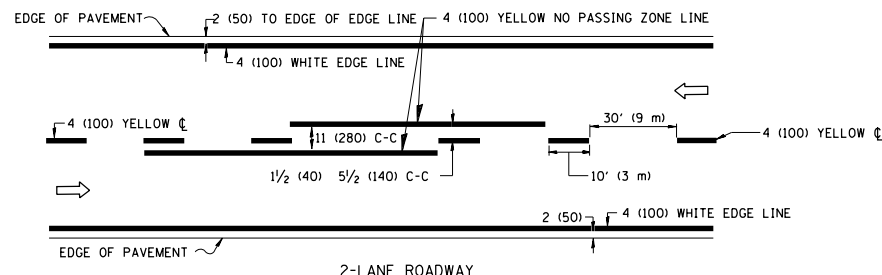

NOTE: MEDIANS WITH BARRIER CURB DO NOT REQUIRE AN EDGE LINE

TYPICAL LANE AND EDGE LINE MARKING

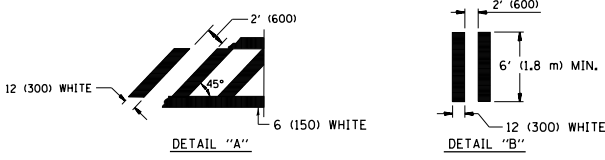
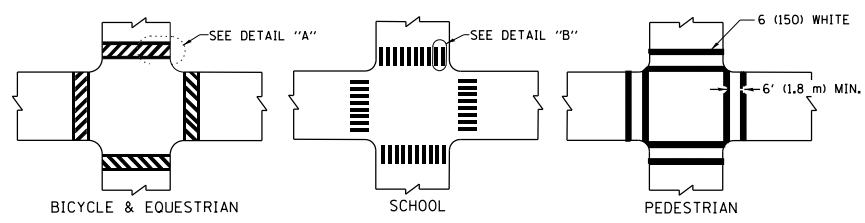

TYPICAL CROSSWALK MARKING

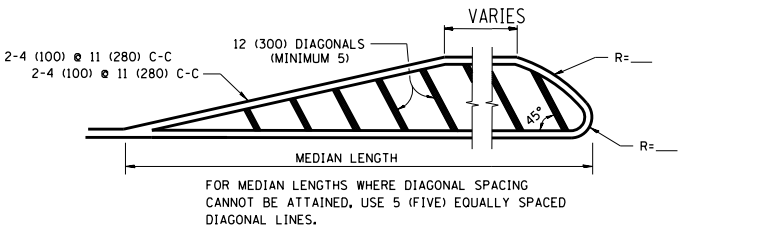
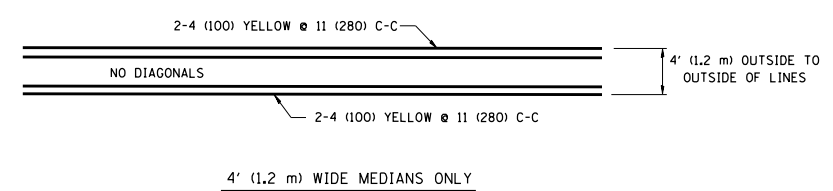

DIAGONAL LINE SPACING: 50' (15 m) C-C (LESS THAN 30MPH (50 km/h))
75' (25 m) C-C 30MPH (50 km/h) TO 45MPH (70 km/h)
150' (45 m) C-C (MORE THAN 45MPH (70 km/h))

MEDIANS OVER 4' (1.2 m) WIDE

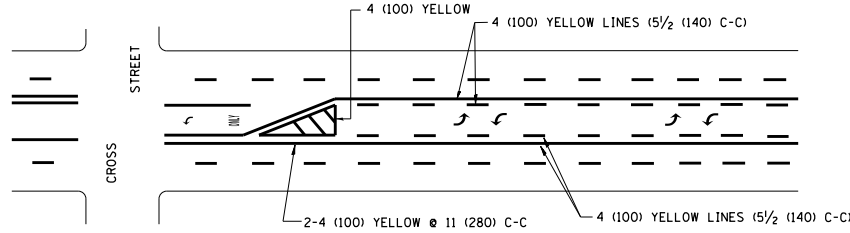

A MINIMUM OF TWO PAIRS OF TURN ARROWS SHALL BE USED, WHITE IN COLOR. ADDITIONAL PAIRS SHALL BE PLACED AT 200' (60 m) TO 300' (90 m) INTERVALS.

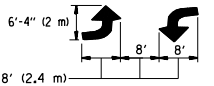

MEDIAN WITH TWO-WAY LEFT TURN LANE

TYPICAL PAINTED MEDIAN MARKING

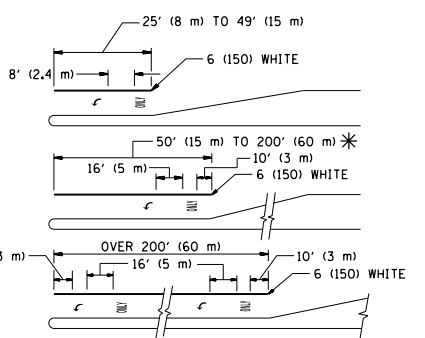

FULL SIZE LETTERS 8' (2.4 m) AND ARROWS SHALL BE USED.
AREA = 15.6 SQ. FT. (1.5 m²) ONLY AREA = 20.8 SQ. FT. (1.9 m²)

* TURN LANES IN EXCESS OF 400' (120 m) IN LENGTH MAY HAVE AN ADDITIONAL SET OF ARROW - "ONLY" INSTALLED MIDWAY BETWEEN THE OTHER TWO SETS OF ARROW - "ONLY".

TYPICAL LEFT (OR RIGHT) TURN LANE

TYPICAL TURN LANE MARKING

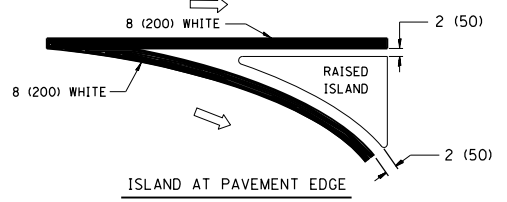
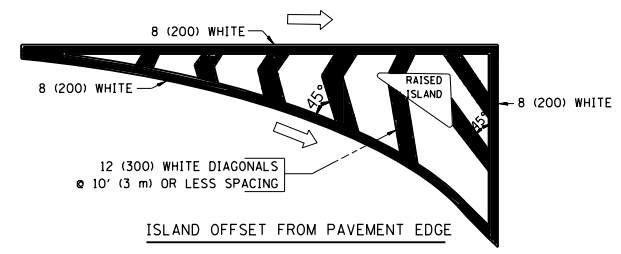

TYPICAL ISLAND MARKING

TYPE OF MARKING	WIDTH OF LINE	PATTERN	COLOR	SPACING / REMARKS
CENTERLINE ON 2 LANE PAVEMENT	4 (100)	SKIP-DASH	YELLOW	10' (3 m) LINE WITH 30' (9 m) SPACE
CENTERLINE ON MULTI-LANE UNDIVIDED PAVEMENT	2 @ 4 (100)	SOLID	YELLOW	11 (280) C-C
NO PASSING ZONE LINES: FOR ONE DIRECTION	4 (100)	SOLID	YELLOW	5/2 (140) C-C FROM SKIP-DASH CENTERLINE
NO PASSING ZONE LINES: FOR BOTH DIRECTIONS	2 @ 4 (100)	SOLID	YELLOW	11 (280) C-C OMIT SKIP-DASH CENTERLINE BETWEEN
LANE LINES	4 (100) 5 (125) ON FREEWAYS	SKIP-DASH SKIP-DASH	WHITE WHITE	10' (3 m) LINE WITH 30' (9 m) SPACE
DOTTED LINES (EXTENSIONS OF CENTER, LANE OR TURN LANE MARKINGS)	SAME AS LINE BEING EXTENDED	SKIP-DASH	SAME AS LINE BEING EXTENDED	2' (600) LINE WITH 6' (1.8 m) SPACE
EDGE LINES	4 (100)	SOLID	YELLOW-LEFT WHITE-RIGHT	OUTLINE MOUNTABLE MEDIANS IN YELLOW; EDGE LINES ARE NOT USED NEXT TO BARRIER CURB
TURN LANE MARKINGS	6 (150) LINE; FULL SIZE LETTERS & SYMBOLS (8' (2.4m))	SOLID	WHITE	SEE TYPICAL TURN LANE MARKING DETAIL
TWO WAY LEFT TURN MARKING	2 @ 4 (100) EACH DIRECTION 8' (2.4m) LEFT ARROW	SKIP-DASH AND SOLID IN PAIRS	YELLOW WHITE	10' (3 m) LINE WITH 30' (9 m) SPACE FOR SKIP-DASH; 5/2 (140) C-C BETWEEN SOLID LINE AND SKIP-DASH LINE. SEE TYPICAL TWO-WAY LEFT TURN MARKING DETAIL
CROSSWALK LINES (PEDESTRIAN) A. DIAGONALS (BIKE & EQUESTRIAN) B. LONGITUDINAL BARS (SCHOOL)	2 @ 6 (150) 12 (300) @ 45° 12 (300) @ 90°	SOLID SOLID SOLID	WHITE WHITE WHITE	NOT LESS THAN 6' (1.8 m) APART 2' (600) APART 2' (600) APART SEE TYPICAL CROSSWALK MARKING DETAILS.
STOP LINES	24 (600)	SOLID	WHITE	PLACE 4' (1.2 m) IN ADVANCE OF AND PARALLEL TO CROSSWALK, IF PRESENT. OTHERWISE, PLACE AT DESIRED STOPPING POINT, PARALLEL TO CROSSROAD CENTERLINE, WHERE POSSIBLE
PAINTED MEDIANS	2 @ 4 (100) WITH 12 (300) DIAGONALS @ 45° NO DIAGONALS USED FOR 4' (1.2 m) WIDE MEDIANS	SOLID	YELLOW; TWO WAY TRAFFIC WHITE; ONE WAY TRAFFIC	11 (280) C-C FOR THE DOUBLE LINE. SEE TYPICAL PAINTED MEDIAN MARKING.
GORE MARKING AND CHANNELIZING LINES	8 (200) WITH 12 (300) DIAGONALS @ 45°	SOLID	WHITE	DIAGONALS: 15' (4.5 m) C-C (LESS THAN 30MPH (50 km/h)) 20' (6 m) C-C 30MPH (50 km/h) TO 45MPH (70 km/h) 30' (9 m) C-C (OVER 45MPH (70 km/h))
RAILROAD CROSSING	24 (600) TRANSVERSE LINES; "RR" 15 6' (1.8 m) LETTERS; 16 (400) LINE FOR "X"	SOLID	WHITE	SEE STATE STANDARD 780001 AREA OF: "R": 3.6 SQ. FT. (0.33 m ²) EACH "X": 54.0 SQ. FT. (5.0 m ²) EACH
SHOULDER DIAGONALS	12 (300) @ 45°	SOLID	WHITE - RIGHT YELLOW - LEFT	50' (15 m) C-C (LESS THAN 30MPH (50 km/h)) 75' (25 m) C-C (30 MPH (50 km/h) TO 45MPH (70 km/h)) 150' (45 m) C-C (OVER 45MPH (70 km/h))

FOR FURTHER DETAILS ON PAVEMENT MARKING REFER TO STANDARD SPECIFICATIONS FOR ROAD AND BRIDGE CONSTRUCTION AND STATE STANDARD 780001.

All dimensions are in inches (millimeters) unless otherwise shown.

FILE NAME =	USER NAME = phillipsdo	DESIGNED - EVERS	REVISED - T. RAMMACHER 10-27-94
et:\pw\work\p\std\phillipsdo\d0276648\Std.dgn		DRAWN -	REVISED - C. JUCIUS 09-09-09
	PLOT SCALE = 100.0000' / in.	CHECKED -	REVISED -
	PLOT DATE = 6/9/2014	DATE - 03-19-90	REVISED -

**STATE OF ILLINOIS
DEPARTMENT OF TRANSPORTATION**

DISTRICT ONE			
TYPICAL PAVEMENT MARKINGS			
SCALE: NONE	SHEET NO. 1 OF 1 SHEETS	STA.	TO STA.

F.A.P. RTE.	SECTION	COUNTY	TOTAL SHEETS	SHEET NO.
352	2R-1-RS-1	LAKE	24	19
TC-13		CONTRACT NO.	60P11	
FED. ROAD DIST. NO. 1 ILLINOIS FED. AID PROJECT				

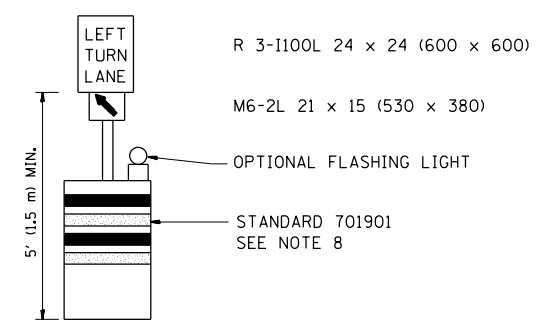
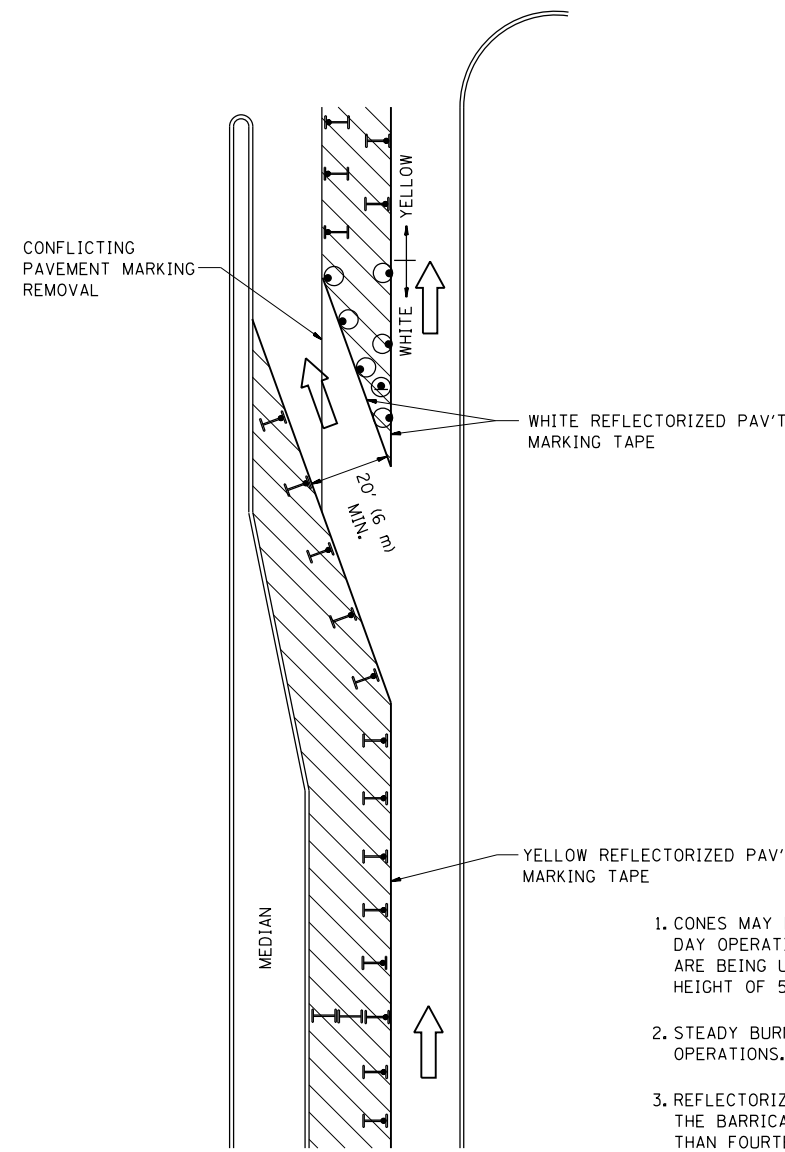







GENERAL NOTES

1. CONES MAY BE SUBSTITUTED FOR BARRICADES OR DRUMS AT HALF THE SPACING DURING DAY OPERATIONS. CONES SHALL BE A MINIMUM OF 28 (710) IN HEIGHT. WHEN CONES ARE BEING USED, THE "LEFT TURN LANE" SIGN MAY BE SKID MOUNTED AT A MINIMUM HEIGHT OF 5' (1.5 m).
2. STEADY BURNING LIGHTS WILL NOT BE REQUIRED ON BARRICADES OR DRUMS FOR DAY OPERATIONS. ALL LIGHTS SHALL BE MONODIRECTIONAL.
3. REFLECTORIZED TEMPORARY PAVEMENT MARKING TAPE SHALL BE PLACED THROUGHOUT THE BARRICADED AREA OF EACH TURN BAY WHERE THE CLOSURE TIME IS GREATER THAN FOURTEEN DAYS.
4. THIS APPLICATION ALSO APPLIES WHEN WORK IS BEING PERFORMED IN THE RIGHT LANE(S) AND THE RIGHT TURN BAY IS TO REMAIN OPEN. UNDER THIS CONDITION, "RIGHT TURN LANE" R3-100 24 x 24 (600 x 600) AND M6-2R 21 x 15 (530 x 380) SHALL BE USED.
5. THESE CONTROLS SHALL SUPPLEMENT MAINLINE TRAFFIC CONTROL FOR LANE CLOSURES.
6. LONGITUDINAL DIMENSIONS MAY BE ADJUSTED TO FIT FIELD CONDITIONS.
7. FORM OPER 725 IS REQUIRED.
8. IF A DRUM OR TYPE II BARRICADE WITH AN ATTACHED SIGN PANEL WHICH MEETS NCHRP 350 REQUIREMENTS IS NOT AVAILABLE, THE SIGNS SHALL BE MOUNTED, ABOVE THE BARRICADES, ON SEPARATE SIGNS SUPPORTS THAT MEET NCHRP 350 PREQUIREMENTS.
9. TRAFFIC CONTROL AND PROTECTION AT TURN BAYS (TO REMAIN OPEN TO TRAFFIC) SHALL BE INCLUDED IN THE COST SPECIFIED TRAFFIC CONTROL STANDARDS OR ITEMS.

All dimensions are in inches (millimeters) unless otherwise shown.

LEGEND

-  WORK AREA
-  LANE OPEN TO TRAFFIC
-  TYPE I OR II BARRICADE WITH STEADY BURN LIGHT
-  DRUM WITH STEADY BURN LIGHT
-  DRUM WITH SIGN (WITH OPTIONAL FLASHING LIGHT) SEE DETAIL
-  TYPE I OR II CHECK BARRICADE WITH FLASHING LIGHT

FILE NAME =	USER NAME = phillipsdo	REVISED -T, RAMMACHER 09-08-94	REVISED - R, BORO 09-14-09
et:\pw\work\pwidot\phillipsdo\d0276648\Std.dgn		REVISED - A. HOUSEH 11-07-95	REVISED -
	PLOT SCALE = 100.0000' / in.	REVISED - A. HOUSEH 10-12-96	REVISED -
	PLOT DATE = 6/9/2014	REVISED -T, RAMMACHER 01-06-00	REVISED -

**STATE OF ILLINOIS
DEPARTMENT OF TRANSPORTATION**

**TRAFFIC CONTROL AND PROTECTION AT TURN BAYS
(TO REMAIN OPEN TO TRAFFIC)**

SCALE: NONE SHEET NO. 1 OF 1 SHEETS STA. TO STA.

F.A.P. RTE.	SECTION	COUNTY	TOTAL SHEETS	SHEET NO.
352	2R-1-RS-1	LAKE	24	20
TC-14		CONTRACT NO.	60P11	
FED. ROAD DIST. NO. 1 ILLINOIS FED. AID PROJECT				

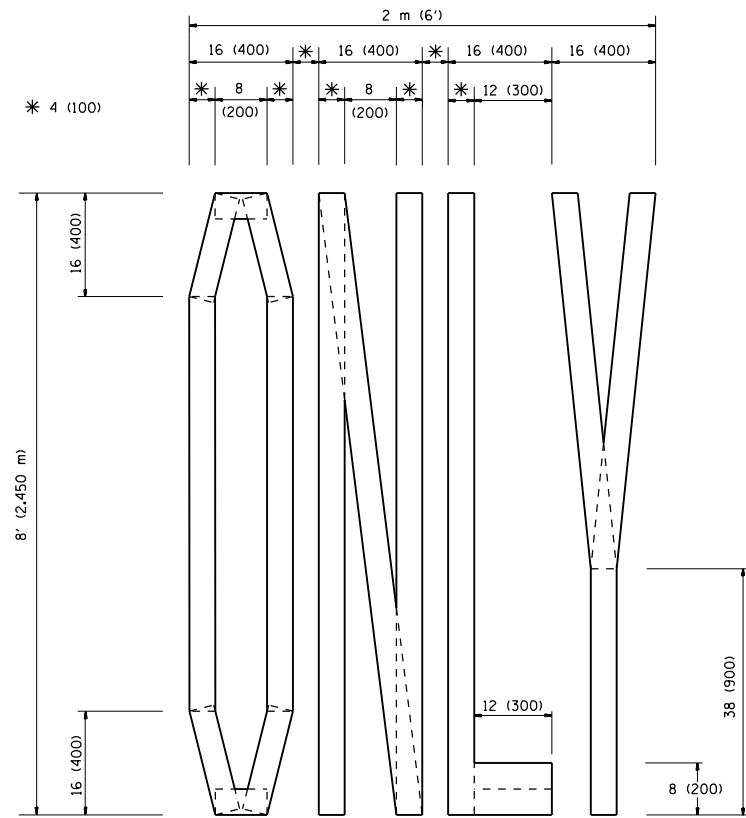

QUANTITY
 4 (100) LINE = 64.1 ft. (19.7 m)
 21.1 sq. ft. (1.97 sq. m)

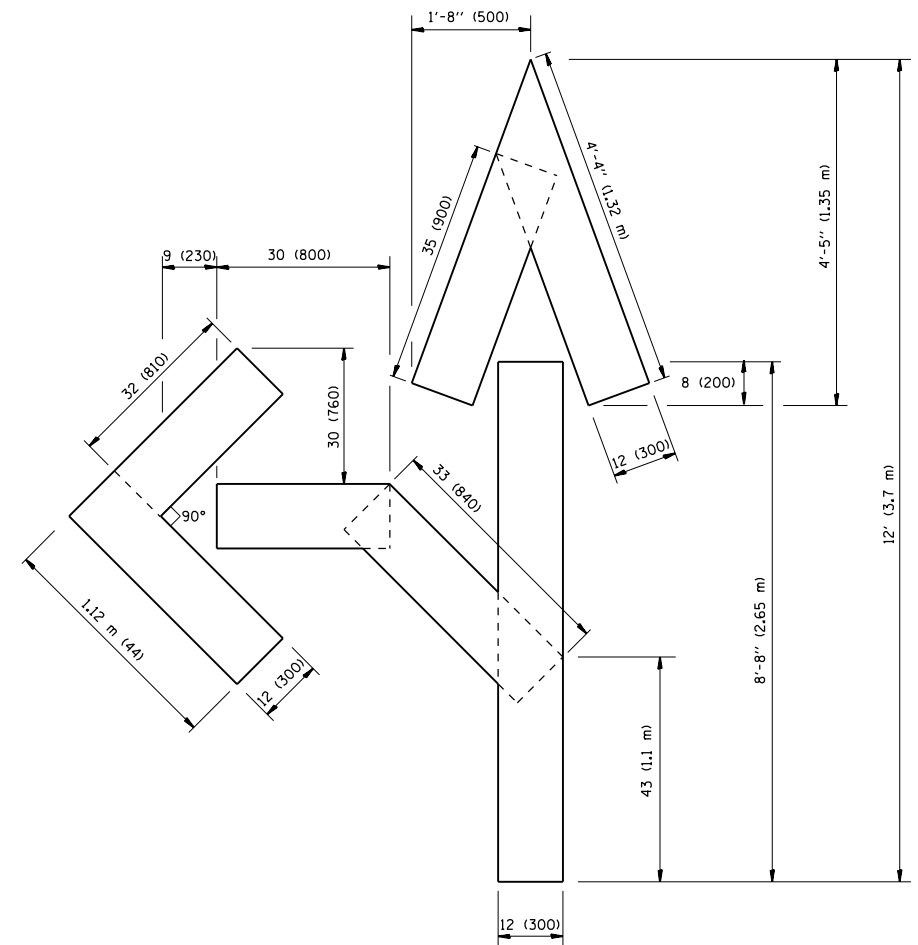

QUANTITY
 4 (100) LINE = 82.5 ft. (25.3 m)
 27.5 sq. ft. (2.53 sq. m)

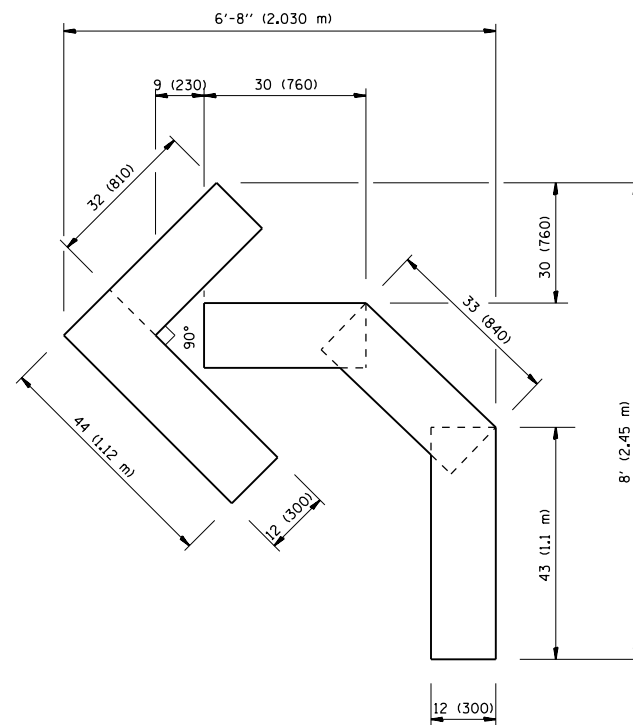

QUANTITY
 4 (100) LINE = 45.5 ft. (13.9 m)
 15.2 sq. ft. (1.39 sq. m)

All dimensions are in inches (millimeters) unless otherwise shown.

FILE NAME =	USER NAME = philipsdo	DESIGNED -	REVISED -T. RAMMACHER 06-05-96
et:\pw\work\p\dot\philipsdo\d0276648\Std.dgn		DRAWN -	REVISED -T. RAMMACHER 11-04-97
PLOT SCALE = 100.0000' / in.		CHECKED -	REVISED -T. RAMMACHER 03-02-98
PLOT DATE = 6/9/2014		DATE - 09-18-94	REVISED -E. GOMEZ 08-28-00

STATE OF ILLINOIS
 DEPARTMENT OF TRANSPORTATION

PAVEMENT MARKING LETTERS AND SYMBOLS
 FOR TRAFFIC STAGING

SCALE: NONE SHEET NO. 1 OF 1 SHEETS STA. TO STA.

F.A.P. RTE.	SECTION	COUNTY	TOTAL SHEETS	SHEET NO.
352	2R-1-RS-1	LAKE	24	21
TC-16		CONTRACT NO. 60P11		
FED. ROAD DIST. NO. 1 ILLINOIS FED. AID PROJECT				

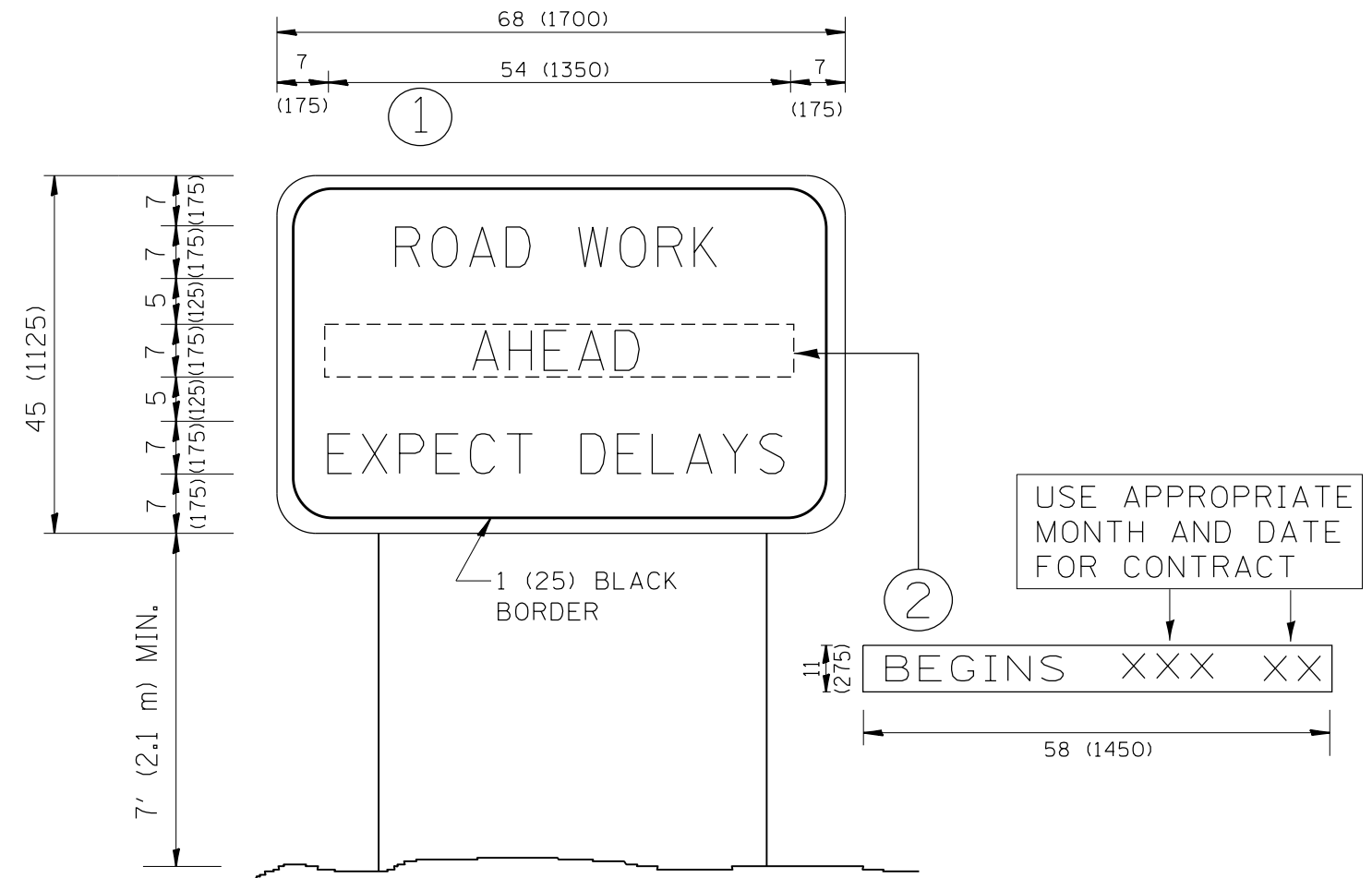

NOTES:

1. USE BLACK LETTERING ON ORANGE BACKGROUND.
2. ERECT SIGNS IN ADVANCE OF THE LOCATION FOR THE "ROAD CONSTRUCTION AHEAD" SIGN AT LOCATIONS AS DIRECTED BY THE ENGINEER.
3. ERECT SIGN ① WITH INSTALLED PANEL ② ONE WEEK PRIOR TO THE START OF CONSTRUCTION.
4. REMOVE PANEL ② SOON AFTER THE START OF CONSTRUCTION.
5. SEE SPECIAL PROVISION FOR "TEMPORARY INFORMATION SIGNING" FOR ADDITIONAL INFORMATION.
6. ONE SIGN ASSEMBLY EQUALS 25.70 SQ. FT. (2.3 SQ. M.)
7. SHALL BE PAID FOR AS TEMPORARY INFORMATION SIGNING.

ALL DIMENSIONS ARE IN INCHES (MILLIMETERS) UNLESS OTHERWISE SHOWN.

FILE NAME =	USER NAME = phillipsdo	DESIGNED -	REVISED - R. MIRS 09-15-97
et:\pwork\pwork\phillipsdo\d0276648\Std.dgn		DRAWN -	REVISED - R. MIRS 12-11-97
	PLOT SCALE = 100.0000' / in.	CHECKED -	REVISED - T. RAMMACHER 02-02-99
	PLOT DATE = 6/9/2014	DATE -	REVISED - C. JUCIUS 01-31-07

**STATE OF ILLINOIS
DEPARTMENT OF TRANSPORTATION**

**ARTERIAL ROAD
INFORMATION SIGN**

SCALE: NONE SHEET NO. 1 OF 1 SHEETS STA. TO STA.

F.A.P. RTE.	SECTION	COUNTY	TOTAL SHEETS	SHEET NO.
352	2R-1-RS-1	LAKE	24	22
TC-22		CONTRACT NO. 60P11		
FED. ROAD DIST. NO. 1 ILLINOIS FED. AID PROJECT				

LOOP DETECTOR NOTES

1. EACH PAIR OF LOOP WIRES SHALL BE PLACED IN A SEPARATE EMPTY COILABLE NONMETALLIC CONDUIT FROM THE EDGE OF PAVEMENT TO THE HANDHOLE. SPACING BETWEEN THE HOLES DRILLED IN THE PAVEMENT SHALL NOT BE LESS THAN 6" (150 mm). EMPTY COILABLE NONMETALLIC CONDUIT SHALL BE INCLUDED IN THE COST OF THE LOOP WIRE.
2. THE NUMBER OF LOOP TURNS SHALL BE AS RECOMMENDED BY THE AMPLIFIER MANUFACTURER. ALL ADJACENT SIDES OF THE LOOPS SHALL BE INSTALLED IN SUCH A WAY THAT THE CURRENT FLOW IS IN THE SAME DIRECTION TO REINFORCE ITS MAGNETIC FIELDS FOR SMALL VEHICLE DETECTION.
3. EACH LOOP LEAD-IN SHALL BE IDENTIFIED AND PERMANENTLY TAGGED IN THE HANDHOLE. EACH LEAD-IN CABLE TAG SHALL INDICATE THE LOCATION OF THE LOOP, LOOP ROTATION (CLOCKWISE/COUNTERCLOCKWISE), LOOP LEAD-IN DIRECTION (IN OR OUT), LOOP CABLE NUMBER AND LOCATION IN CABINET, AND NUMBER OF TURNS IN THE DETECTOR LOOPS IN WATER PROOF INK AS INDICATED ON THE DISTRICT 1 STANDARD TRAFFIC SIGNAL DESIGN DETAIL. THE CONTRACTOR SHALL MARK LOOP LOCATIONS ON RECORD DRAWINGS AND PRESENT TO THE ENGINEER AFTER FINAL INSPECTION. LOOPS SHALL BE MARKED BY LANE AND LOOP NUMBER. SEE DETAIL BELOW.
4. ALL LOOP CABLE SHALL BE FASTENED WITH PLASTIC TIE WRAP TO THE HANDHOLE HOOKS.
5. IN ASPHALT PAVEMENT, LOOPS SHOULD BE PLACED IN THE BINDER AND DIVEHOLES MARKED AT THE CURB WITH A SAW-CUT. THE SAW-CUT SHALL BE CUT IN ACCORDANCE WITH LOCAL AND E.P.A. DUST CONTROL REQUIREMENTS. DETECTOR LOOP(S) SHALL NOT BE INSTALLED IN WET CONDITIONS AND THE SAW-CUTS MUST BE FREE OF DEBRIS AND RESIDUE SUCH AS DUST AND WATER WHICH IS TO BE ACHIEVED BY THE USE OF COMPRESSED AIR, WIRE BRUSHING AND HEAT DRYING ACCORDING TO SEALANT MANUFACTURER REQUIREMENTS. THE DETECTOR WIRE SHALL BE HELD IN PLACE BY THE USE OF FORM WEDGES. WEDGES SHALL BE SPACED NO MORE THAN 18" (450 mm) APART.
6. LOOP SPLICES SHALL BE SOLDERED USING A SOLDERING IRON. BLOW TORCHES OR OTHER DEVICES WHICH OXIDIZE COPPER CABLE SHALL NOT BE ALLOWED FOR SOLDERING OPERATIONS. SEE DETAIL BELOW RIGHT.
7. PREFORMED DETECTOR LOOPS SHALL BE USED, AS SHOWN ON THE PLANS, WHERE NEW CONCRETE PAVEMENT IS PROPOSED. THE INSTALLATION OF PREFORMED LOOPS SHALL BE IN ACCORDANCE WITH THE DISTRICT 1 SPECIFICATIONS OR AS DIRECTED BY THE ENGINEER.

LOOP LEAD-IN CABLE TAG

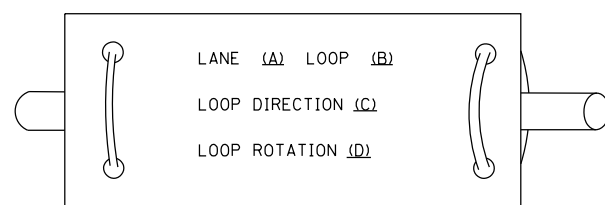

- A. LANE 1 IS THE LANE CLOSEST TO THE CENTERLINE OF THE ROADWAY
- B. LOOP #1 IS THE LOOP IN THE LANE CLOSEST TO THE INTERSECTION.
- C. LABEL LOOP CABLE "IN" OR LOOP CABLE "OUT".
- D. LABEL LOOP CABLE CLOCKWISE OR LOOP CABLE COUNTERCLOCKWISE.

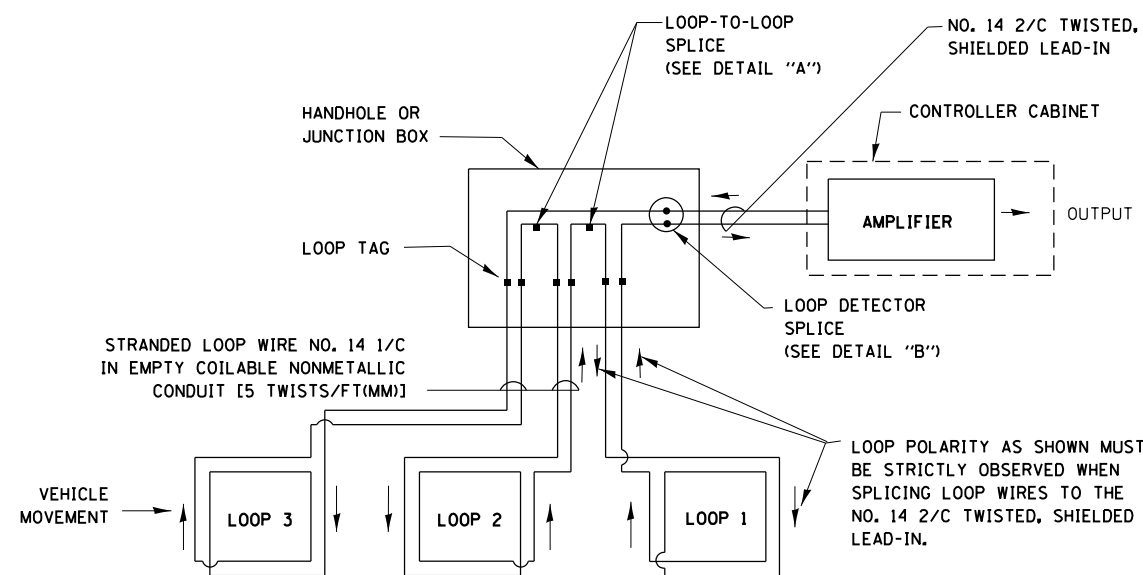

DETECTOR LOOP WIRING SCHEMATIC

- LOOPS SHALL BE SPLICED IN SERIES.
- SAW-CUTS SHALL BE A MINIMUM WIDTH OF 5/16" (8 mm).
- SAW-CUT DEPTHS SHALL BE 3" (75 mm). IF IN CONCRETE, THE SAW-CUT DEPTH SHALL BE TO THE TOP OF THE REINFORCEMENT.
- LOOP CORNERS SHALL BE DRILLED WITH A 2" (50 mm) DIAMETER CORE.

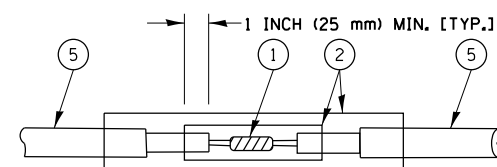

DETAIL "A"
LOOP-TO-LOOP SPLICE

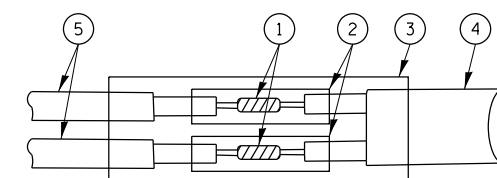

DETAIL "B"
LOOP-TO-CONTROLLER SPLICE

TYPE I LOOP

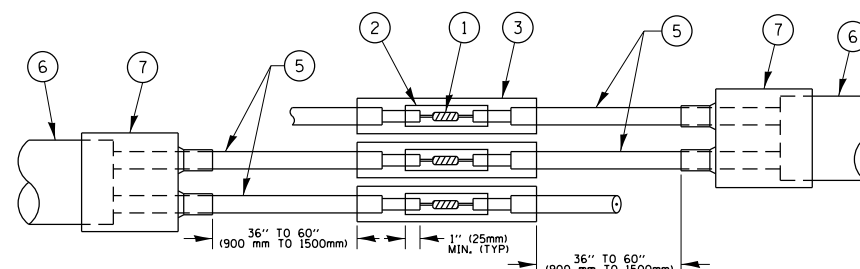

DETAIL "A"
LOOP-TO-LOOP SPLICE

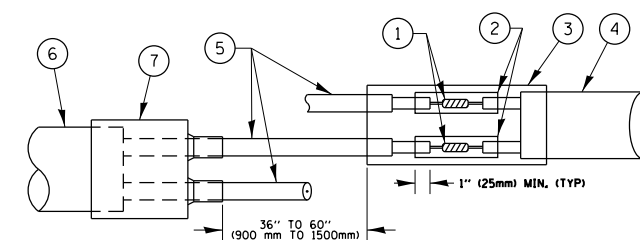

DETAIL "B"
LOOP-TO-CONTROLLER SPLICE

LOOP DETECTOR SPLICE

- 1 WESTERN UNION SPLICE SOLDERED WITH ROSIN CORE FLUX. ALL EXPOSED SURFACES OF THE SOLDER SHALL BE SMOOTH, THE WESTERN UNION SPLICES SHALL BE STAGGERED.
- 2 WCSMW 30/100 HEAT SHRINK TUBE, MINIMUM LENGTH 3" (75 mm), UNDERWATER GRADE.
- 3 WCS 200/750 HEAT SHRINK TUBE, MINIMUM LENGTH 6" (150 mm), UNDERWATER GRADE.
- 4 NO. 14 2/C TWISTED, SHIELDED CABLE.
- 5 LOOP CONDUCTOR WITH FLEXIBLE PLASTIC TUBE.
- 6 PRE-FORMED LOOP
- 7 XL POLYOLEFIN 2 CONDUCTOR BREAKOUT SEALS, TYCO CBR-2 OR APPROVED EQUAL

FILE NAME =	USER NAME = philipsdo	DESIGNED - DAD	REVISED - DAG 1-1-14
et:\pw\work\p\dot\philipsdo\d0276648\Std.dgn		DRAWN - BCK	REVISED -
	PLOT SCALE = 100.0000' / in.	CHECKED - DAD	REVISED -
	PLOT DATE = 6/9/2014	DATE - 10-28-09	REVISED -

**STATE OF ILLINOIS
DEPARTMENT OF TRANSPORTATION**

DISTRICT ONE			
STANDARD TRAFFIC SIGNAL DESIGN DETAILS			
SCALE: NONE	SHEET NO. 2 OF 7 SHEETS	STA.	TO STA.

F.A. RTE.	SECTION	COUNTY	TOTAL SHEETS	SHEET NO.
352	2R-1-RS-1	LAKE	24	23
TS-05		CONTRACT NO.	60P11	
FED. ROAD DIST. NO. 1 ILLINOIS FED. AID PROJECT				

LOOPS NEXT TO SHOULDERS

PROVIDE A PAVEMENT REPLACEMENT NOTE WHICH SHOULD EQUAL 3' (900 mm) X WIDTH OF PAVED SHOULDER.

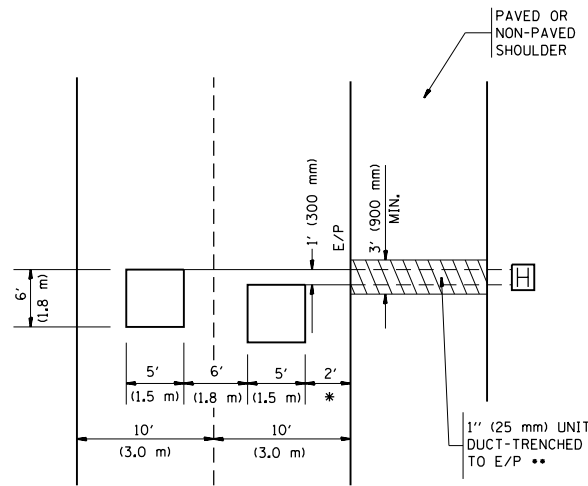

* = (600 mm)

** UNIT DUCT IS TO BE SHOWN ON PLAN SHEETS BUT SHALL NOT BE INCLUDED IN THE PAY ITEMS.

**LEFT TURN LANES WITH MEDIANS
VOLUME DENSITY ("FAR OUT" DETECTION)
ON SAME APPROACH**

(PROTECTED / PERMITTED LEFT TURN PHASING)

HANDHOLE LOCATION MAY VARY DEPENDING ON GEOMETRICS AND DESIGN OF TRAFFIC SIGNALS. HEAVY-DUTY HANDHOLES TO BE USED WHEN THE MEDIAN IS MOUNTABLE. REFER TO STANDARD 814001 TO ENSURE THAT HANDHOLE FITS IN MEDIAN.

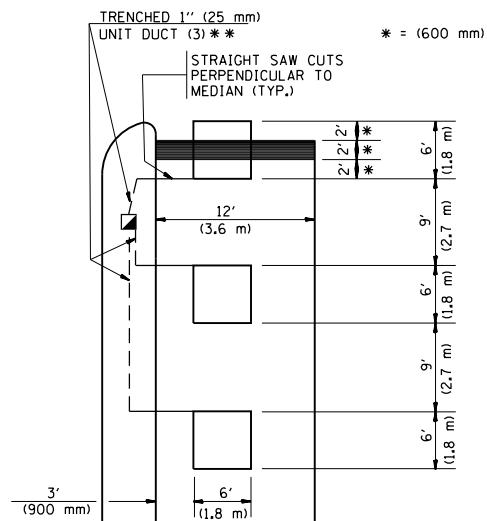

** UNIT DUCT IS TO BE SHOWN ON PLAN SHEETS BUT SHALL NOT BE INCLUDED IN THE PAY ITEMS.

NOTE: DUAL LEFT TURNS NOT SHOWN REFER TO PLAN SHEET FOR DETECTOR LOOP REPLACEMENT

**LEFT TURN LANES WITHOUT MEDIANS
VOLUME DENSITY ("FAR OUT" DETECTION)
ON SAME APPROACH**

(PROTECTED / PERMITTED LEFT TURN PHASING)

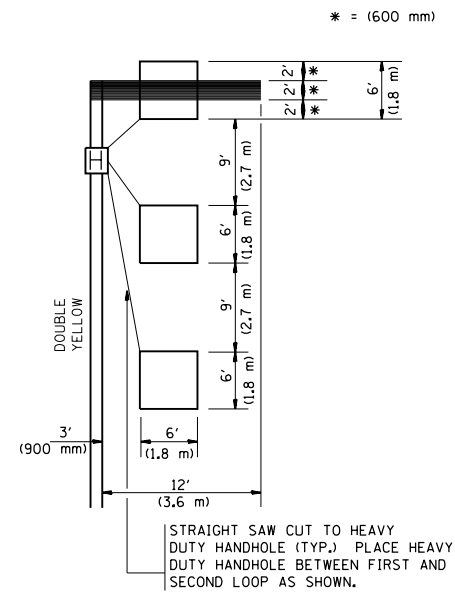

NOTE: DUAL LEFT TURNS NOT SHOWN REFER TO PLAN SHEET FOR DETECTOR LOOP REPLACEMENT

NOTES:

VEHICLES LOOP DETECTORS

- * ALL LEAD IN CABLE SHALL BE TWO CONDUCTOR NO. 14 TWISTED, SHIELDED.
- * EACH DETECTOR LOOP SHALL HAVE ITS OWN SAW CUT FROM THE LOOP TO THE EDGE OF PAVEMENT OR TO A HANDHOLE IN THE PAVEMENT.
- * EACH DETECTOR LOOP SHALL HAVE ITS OWN ONE INCH (25 mm) UNIT DUCT BETWEEN THE EDGE OF PAVEMENT AND THE FIRST HANDHOLE OR JUNCTION BOX. EACH UNIT DUCT RUN SHALL BE SHOWN ON THE PLANS BY THE DESIGNER, BUT SHALL NOT BE PAID FOR SEPARATELY. THIS ITEM IS INCIDENTAL TO THE PAY ITEM FOR DETECTOR LOOPS.
- * ONE DIMENSION OF ALL DETECTOR LOOPS SHALL BE SIX FEET (1.8 m)
- * EACH LANE OF NON-LOCKING, PRESENCE DETECTION AND EACH LANE OF A DOUBLE LEFT TURN LANE REQUIRES A SEPARATE INDUCTIVE LOOP DETECTOR AND LEAD IN CABLE.
- * WHEN NON-LOCKING, PRESENCE DETECTION IS USED, MORE THAN ONE LOOP PER LANE IS REQUIRED BEHIND THE STOP BAR (i.e. 1-1/2, 1-3/4, 2).
- * WHEN SYSTEM LOOPS ARE REQUIRED ON AN APPROACH OF AN INTERSECTION, THE LOOPS USED FOR VOLUME DENSITY AND INTERSECTION TIMING SHALL ALSO BE USED AS SYSTEM DETECTORS. EACH ONE OF THESE TYPE OF LOOPS REQUIRES A SEPARATE TWO CONDUCTOR NO. 14 TWISTED SHIELDED CABLE AND A SEPARATE INDUCTIVE LOOP DETECTOR WHEN NEW CONTROLLERS ARE UTILIZED. THE DESIGNER SHALL LABEL THESE TYPES OF LOOPS AS "INTERSECTION AND SAMPLING (SYSTEM) DETECTORS" ON THE SIGNAL LAYOUT, THE INTERCONNECT PLAN AND THE SYSTEM CABLE PLAN. WHEN AN EXISTING CONTROLLER IS UTILIZED FOR THIS TYPE OF DETECTION, THE PAY ITEM "INDUCTIVE LOOP DETECTOR WITH SYSTEM OUTPUT" SHOULD BE USED.

PLACEMENT OF DETECTORS

THE FOLLOWING FIGURES REPRESENT THE MOST COMMON DETECTOR LOOP LOCATIONS AND SIZES. ADJUSTMENTS WILL BE NECESSARY FOR SPECIFIC GEOMETRIC CONSIDERATIONS.

LOCATIONS AND DEMENSIONS OF DETECTOR LOOPS ARE REQUIRED ON ALL SIGNAL LAYOUT PLAN SHEETS.

"FAR OUT" DETECTION REFERS TO LOCKING, PRESENCE TYPE DETECTION LOCATED IN THRU LANES, RIGHT TURN LANES, AND RIGHT TURN LANE TAPER AREAS (IF APPLICABLE), USUALLY 250' (75 m) IN ADVANCE OF STOP BARS. "UPTIGHT" DETECTION REFERS TO NON-LOCKING PRESENCE TYPE DETECTION LOCATED IN ALL LANES AND 10'-15' (3.0 m-4.5 m) BEHIND THE CROSSING STREET'S EDGE OF PAVEMENT EXTENDED.

NOTE:

ALL DETAILS AND NOTES SHOWN ARE FROM THE I.D.O.T. DISTRICT 1 TRAFFIC SIGNAL DESIGN GUIDELINES DATED JANUARY 1995

THIS DRAWING HAS BEEN PREPARED TO ASSIST THE RESIDENT ENGINEER FOR ALL ROADWAY RESURFACING OR S.M.A.R.T. PROJECTS WHERE THE DIMENSIONS ARE NOT SHOWN ON THE PLANS AND THE FINAL LOCATIONS FOR CROSSWALKS OR STOP BARS ARE NOT DETERMINED.

**ARTERIAL-VOLUME DENSITY ("FAR OUT" DETECTION)
CROSS STREET-VOLUME DENSITY ("FAR OUT" DETECTION)**

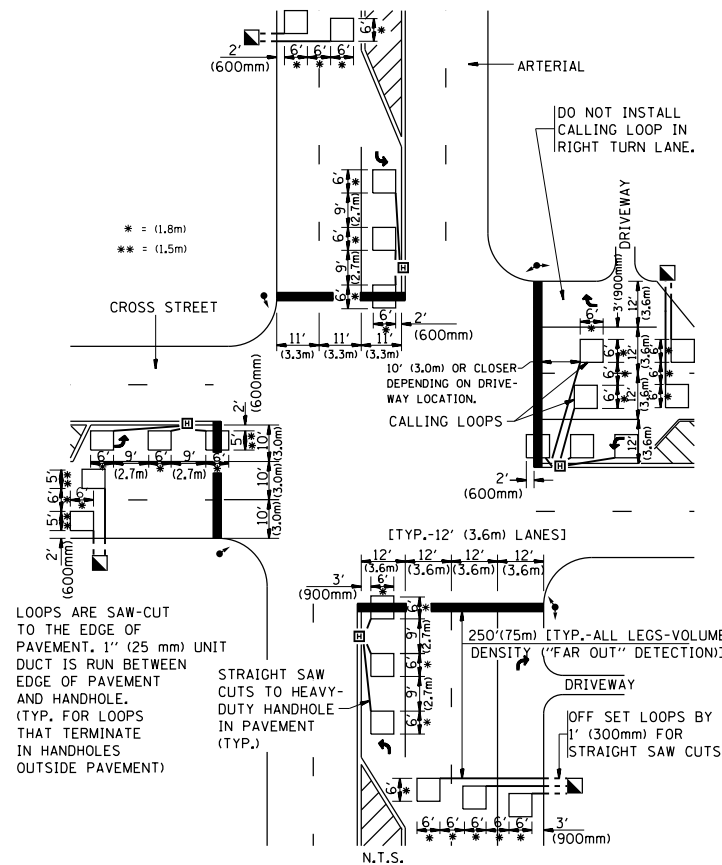

**DETAIL 1
N.T.S.**

**ARTERIAL-VOLUME DENSITY ("FAR OUT" DETECTION)
CROSS STREET-NON VOLUME DENSITY ("UPTIGHT" PRESENCE DETECTION)**

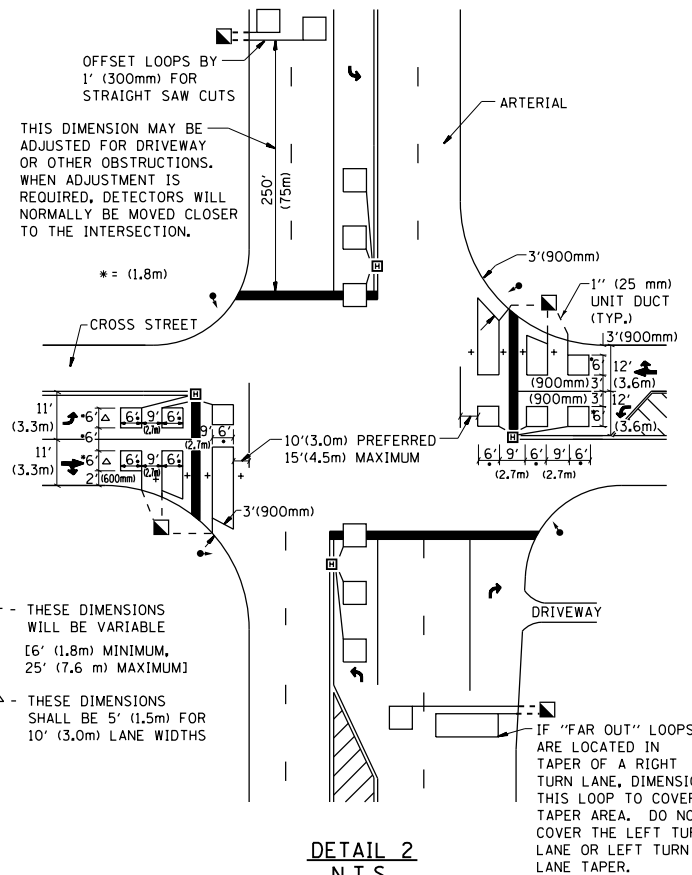

**DETAIL 2
N.T.S.**

FILE NAME =	USER NAME = philipsdo	DESIGNED -	REVISED -
et:\pw\work\pmdot\philipsdo\d0276648\Di...	std.dgn	DRAWN -	REVISED -
	PLOT SCALE = 100.0000' / in.	CHECKED - R.K.F.	REVISED -
	PLOT DATE = 6/9/2014	DATE -	REVISED -

**STATE OF ILLINOIS
DEPARTMENT OF TRANSPORTATION**

**DISTRICT 1 - DETECTOR LOOP INSTALLATION
DETAILS FOR ROADWAY RESURFACING**

SCALE: NONE SHEET NO. 1 OF 1 SHEETS STA. TO STA.

F.A.P. RTE.	SECTION	COUNTY	TOTAL SHEETS	SHEET NO.
352	2R-1-RS-1	LAKE	24	24
TS-07		CONTRACT NO.	60P11	
FED. ROAD DIST. NO. 1 ILLINOIS FED. AID PROJECT				