

**COMB. C & G B6.12 STA. 50+14 TO 52+86
 COMB. C & G B6.24 STA. 54+37 TO STA. 163+82

EXISTING TYPICAL SECTION
 ILL (137) / BUCKLEY ROAD
 STA. 135+00 TO STA. 151+67
 SUPERELEVATED CROSS SECTION

LEGEND

- ① GRASS PARKWAY
- ② EXIST COMB. CONC. CURB AND GUTTER**
- ③ EXIST HOT MIX ASPHALT 14 1/2" (±)
- ④ EXIST PCC 5 1/2" (±)
- ⑤ EXIST HOT-MIX ASPHALT 10" (±)
- ⑥ PROP. HOT-MIX ASPHALT SURFACE REMOVAL 2 1/2"
- ⑦ PROP. POLYMERIZED HOT-MIX ASPHALT SURFACE, MIX "F", N90, 1 3/4"
- ⑧ PROP. POLYMERIZED LEVELING BINDER (MACHINE METHOD), IL-4.75, N50, 3/4"

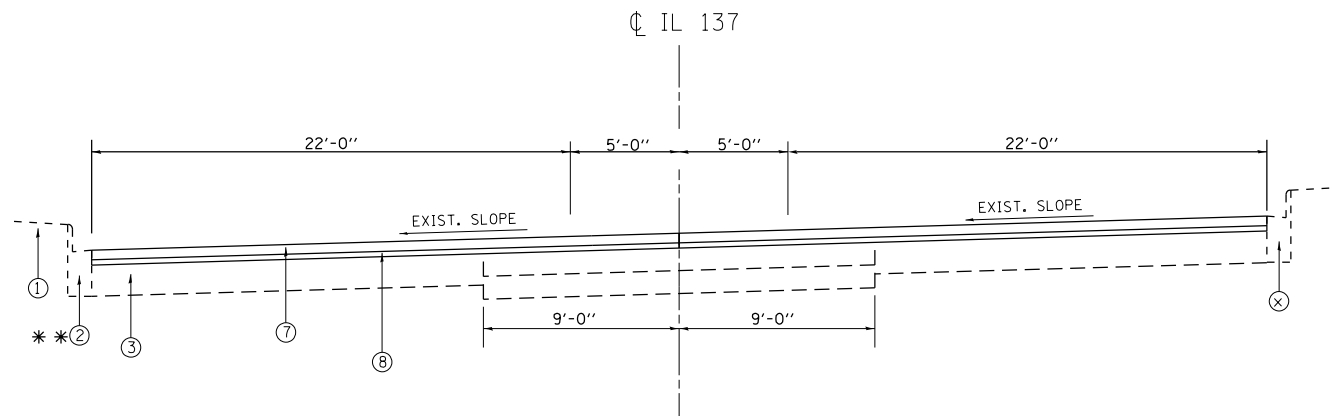

PROPOSED TYPICAL SECTION
 ILL (137) / BUCKLEY ROAD
 STA. 135+00 TO STA. 151+67
 SUPERELEVATED CROSS SECTION

** NOTE: AT LOCATIONS OF CURB AND GUTTER REMOVAL AND REPLACEMENT AS DETERMINED BY THE ENGINEER, THE 18 INCHES BEHIND THE BACK OF CURB SHALL BE REPLACED IN KIND. ITEMS TO BE REPLACED INCLUDE TOPSOIL & SODDING, AGGREGATE SHOULDERS TYPE B AND HMA SHOULDERS. THE REMOVAL OF ALL ITEMS BEHIND THE BACK OF CURB SHALL BE INCLUDED IN THE COST OF COMBINATION CONCRETE CURB AND GUTTER REMOVAL AND REPLACEMENT.

FILE NAME =	USER NAME = Tariqf	DESIGNED -	REVISED -	STATE OF ILLINOIS DEPARTMENT OF TRANSPORTATION	ILL ROUTE 137 (O'PLAINE ROAD TO ILL 21) TYPICAL SECTIONS			F.A.P. RTE.	SECTION	COUNTY	TOTAL SHEETS	SHEET NO.
Default	10-sh:plan.dgn	DRAWN -	REVISED -					352	56RS-3	LAKE	21	6
	PLOT SCALE = 100.0000' / in.	CHECKED -	REVISED -					CONTRACT NO. 60L06				
	PLOT DATE = 6/11/2014	DATE -	REVISED -					SCALE:	SHEET	OF	SHEETS	STA.