

\* Full depth removal to be done in 10' increments along the length of the parapet.

**PLAN**

Hatched areas indicate Deck Slab Repair (Partial)  
Areas of deck repair are estimated. Actual locations shall be shown by the Engineer for As Built Plans.

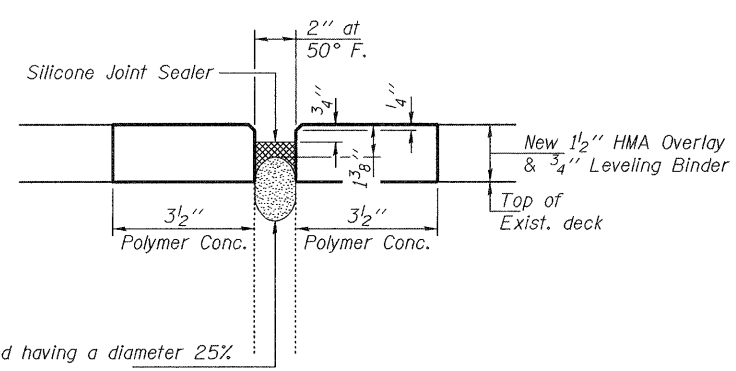

**SECTION THRU JOINT**

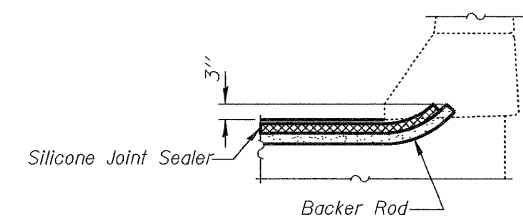

**TYPICAL END OF SEAL TREATMENT**

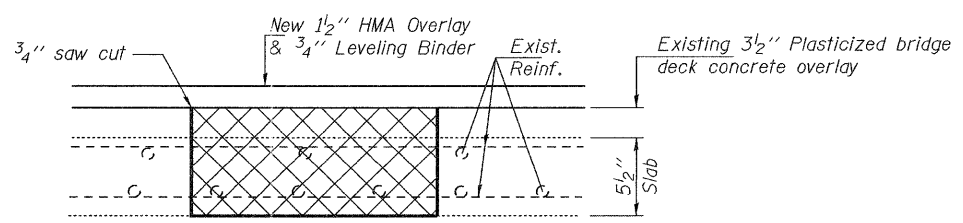

**TYPICAL DECK REPAIR DETAIL**

Cross hatched areas indicate Deck Slab Repair (Full Depth, Type II)

**BILL OF MATERIAL**

| Item   | Unit    | Quantity |
|--|---------|----------|
| Deck Slab Repair (Partial)                               | Sq. Yd. | 100      |
| Deck Slab Repair (Full Depth, Type I)                    | Sq. Yd. | 132      |
| Protective Shield  | Sq. Yd. | 240      |
| Polymerized Hot-Mix Asphalt Surface Course, Mix "D", N90 | Ton     | 62       |
| Silicone Joint Sealer, 2"                                | Foot    | 107      |
| Polymer Concrete   | Cu. Ft. | 10.4     |
| Polymerized Leveling Binder (Machine Method), N50        | Ton     | 26       |

|                              |   |                           |
|------------------------------|---|---------------------------|
| DESIGNED <i>VHV</i>          | EXAMINED  | DATE <i>JUNE 29, 2011</i> |
| CHECKED <i>DAB</i>           | <br>ACTING ENGINEER OF STRUCTURAL SERVICES<br><br>ACTING ENGINEER OF BRIDGES AND STRUCTURES | REVISED                   |
| DRAWN <i>Kyle M. Steffen</i> |   | PASSED                    |
| CHECKED <i>VHV DAB</i>       |   | REVISED                   |

**STATE OF ILLINOIS  
DEPARTMENT OF TRANSPORTATION**

**DECK PATCHING DETAILS  
SN 081-0017 (NB)**

SHEET NO. 3 OF 3 SHEETS

|                    |                                |             |                           |           |
|--------------------|--------------------------------|-------------|---------------------------|-----------|
| F.A.I. RTE.        | SECTION                        | COUNTY      | TOTAL SHEETS              | SHEET NO. |
| 80                 | 137-1B1-1, 81-1VB, 81-1HB-1M-1 | ROCK ISLAND | 15                        | 12        |
| CONTRACT NO. 64H27 |                                |             | ILLINOIS FED. AID PROJECT |           |