

**PLAN**

Hatched areas indicate Deck Slab Repair (Partial). Areas of deck repair are estimated. Actual locations shall be shown by the engineer for As Built Plans.

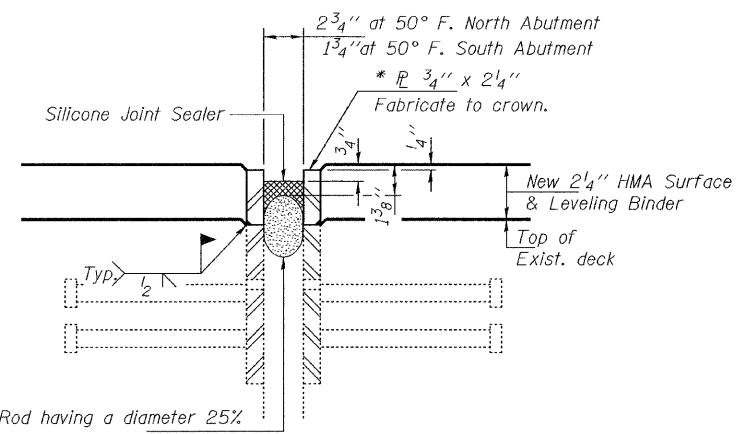

Backer Rod having a diameter 25% greater than the joint opening at the time of installation.

**SECTION THRU JOINT**

\* Furnish in segments of 20 ft. maximum length. Maximum space between installed segments shall be 3/16". Seal space with Silicone Sealant suitable for Structural Steel. After fabrication, all surfaces of the steel R shall be given one shop coat of paint specified for structural steel. No field painting required. Cost included with HMA overlay.

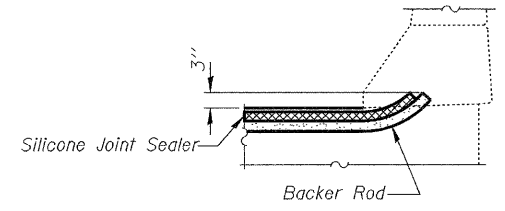

**TYPICAL END OF SEAL TREATMENT**

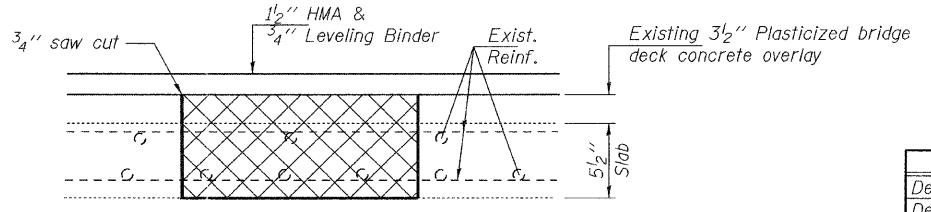

**TYPICAL DECK REPAIR DETAIL**

Cross hatched areas indicate Deck Slab Repair (Full Depth, Type I).

**BILL OF MATERIAL**

Item	Unit	Quantity
Deck Slab Repair (Partial)	Sq. Yd.	100
Deck Slab Repair (Full Depth, Type I)	Sq. Yd.	225
Protective Shield	Sq. Yd.	260
Polymerized Leveling Binder (Machine Method), N50	Ton	28
Polymerized Hot-Mix Asphalt Surface Course, Mix "D", N90	Ton	56
Silicone Joint Sealer, 2 3/4"	Foot	35
Silicone Joint Sealer, 1 3/4"	Foot	35