

CENTER LANE CLOSURE

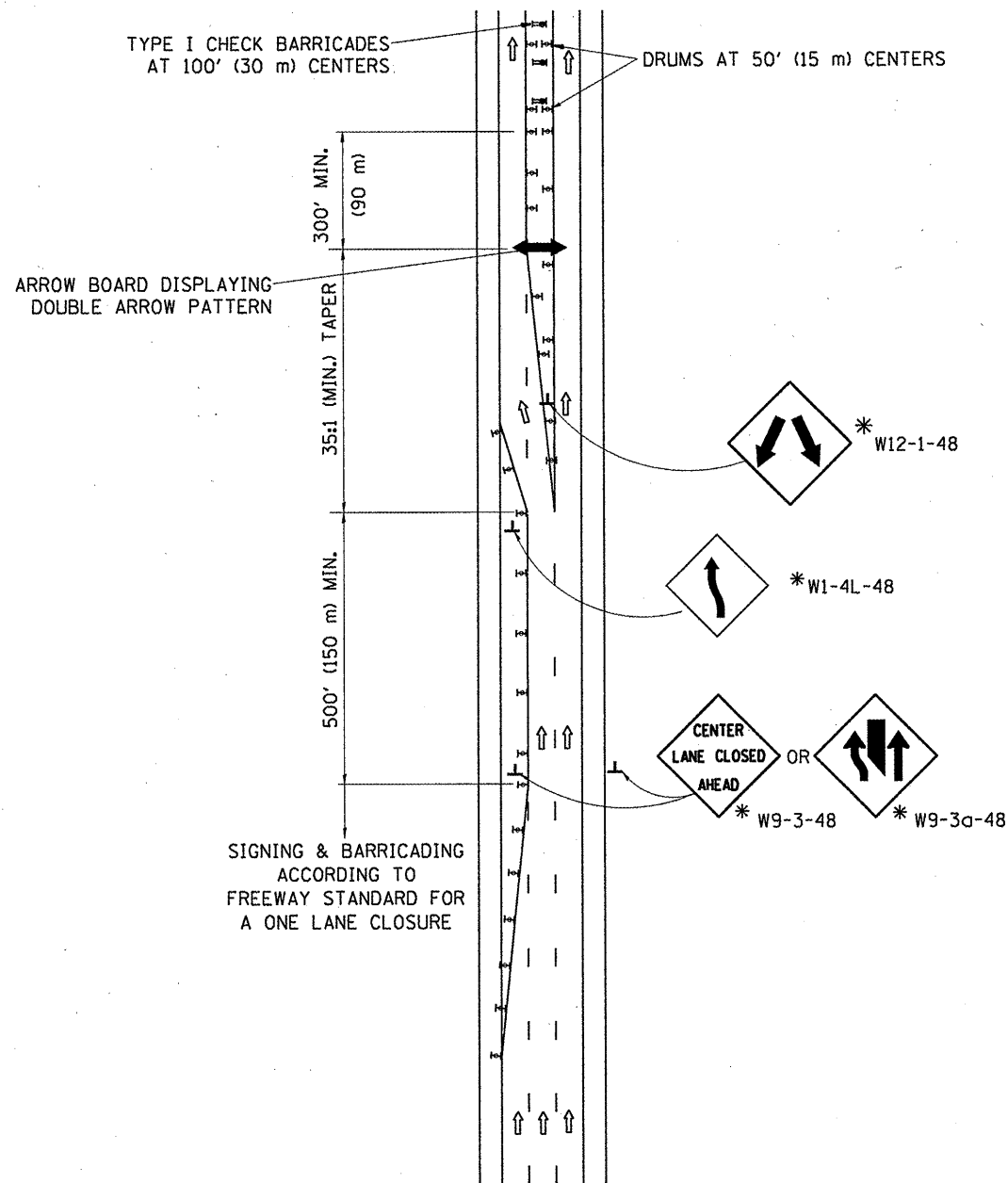

INSTALLATION SEQUENCE

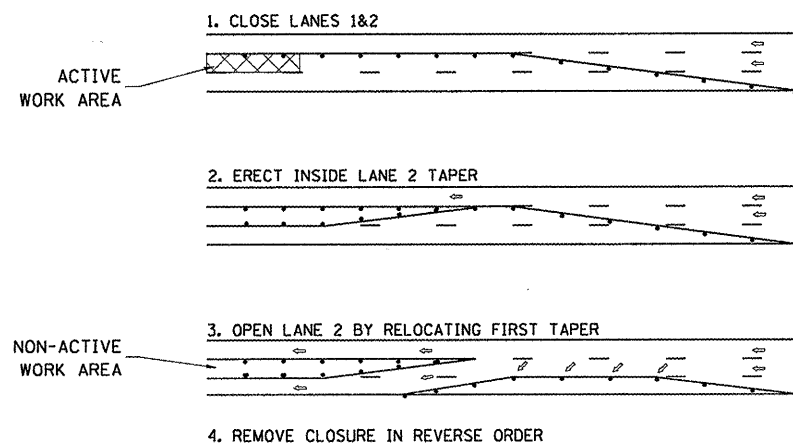

NOTES

1. DRUMS WITH STEADY BURN LIGHTS SHALL BE USED AT 50' (15 m) CENTERS ON ALL TAPERS AND TANGENTS IN ADVANCE OF WORK AREA.
2. CLOSURE SHALL BE USED ONLY FOR OPERATIONS LASTING 72 HOURS OR LESS.
3. CENTER LANE CLOSURE CONFIGURATION IS NOT TO BE USED WITH WORKERS PRESENT.

SHOULDER LANE

NOTE: CLOSURE SHALL BE USED ONLY FOR OPERATIONS LASTING 72 HOURS OR LESS.

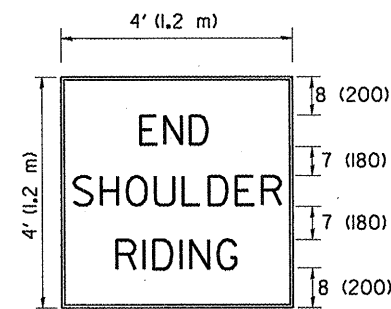
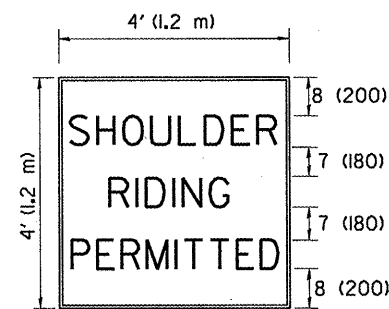
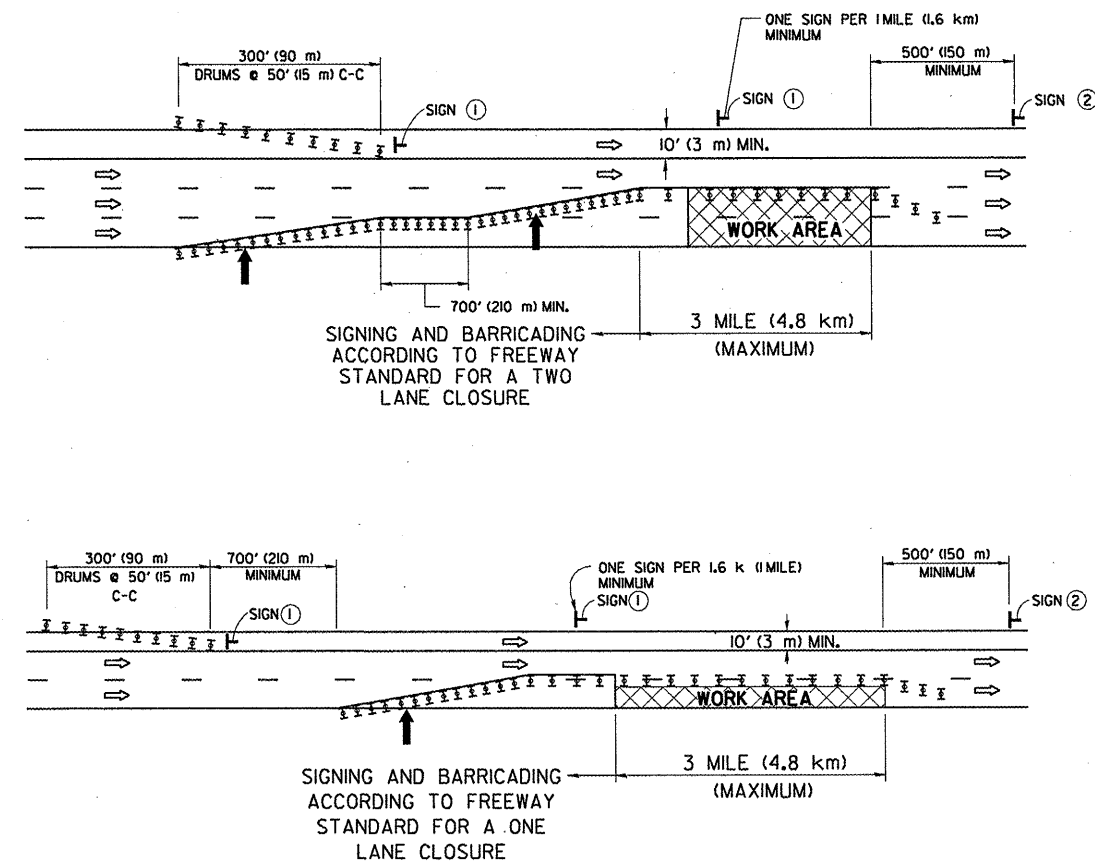

6 (150) SERIES "C" LEGEND
BLACK LEGEND
WHITE REFLECT. BACKGROUND
1(25) BORDER

SYMBOLS

- ↑ DIRECTION OF TRAFFIC
- ➔ ARROWBOARD
- ▣ ACTIVE WORK AREA
- ⊥ SIGN ON PORTABLE OR PERMANENT SUPPORT *
- ⊥ TYPE II BARRICADE, OR DRUM WITH MONO-DIRECTIONAL STEADY BURN LIGHT

ALL DIMENSIONS ARE IN INCHES (MILLIMETERS) UNLESS OTHERWISE SHOWN

* ALL SIGNS SHALL BE MOUNTED AT A MINIMUM HEIGHT OF 5' (1.5 m).

FILE NAME =	USER NAME = VelichkovVV	DESIGNED -	REVISED - J.A.F. 04-03
ca:\pw_work\pwsdot\velichkovvv\d8259794\1stStd.dgn		DRAWN -	REVISED - S.P.B. 01-07
		CHECKED -	REVISED - S.P.B. 12-09
		DATE -	REVISED -

STATE OF ILLINOIS
DEPARTMENT OF TRANSPORTATION

TRAFFIC CONTROL DETAILS FOR FREEWAY
CENTER LANE CLOSURE SHOULDER LANE

SCALE: NONE SHEET NO. 1 OF 1 SHEETS STA. TO STA.

F.A. RTE.	SECTION	COUNTY	TOTAL SHEETS	SHEET NO.
VAR.	2011-002-PP	COOK	22	21
TC-25		CONTRACT NO. 60N90		
FED. ROAD DIST. NO. 1 ILLINOIS FED. AID PROJECT				