

EXISTING TYPICAL SECTION
US ROUTE 34 (EAST LEG)
STATION 114+32 TO STATION 118+94

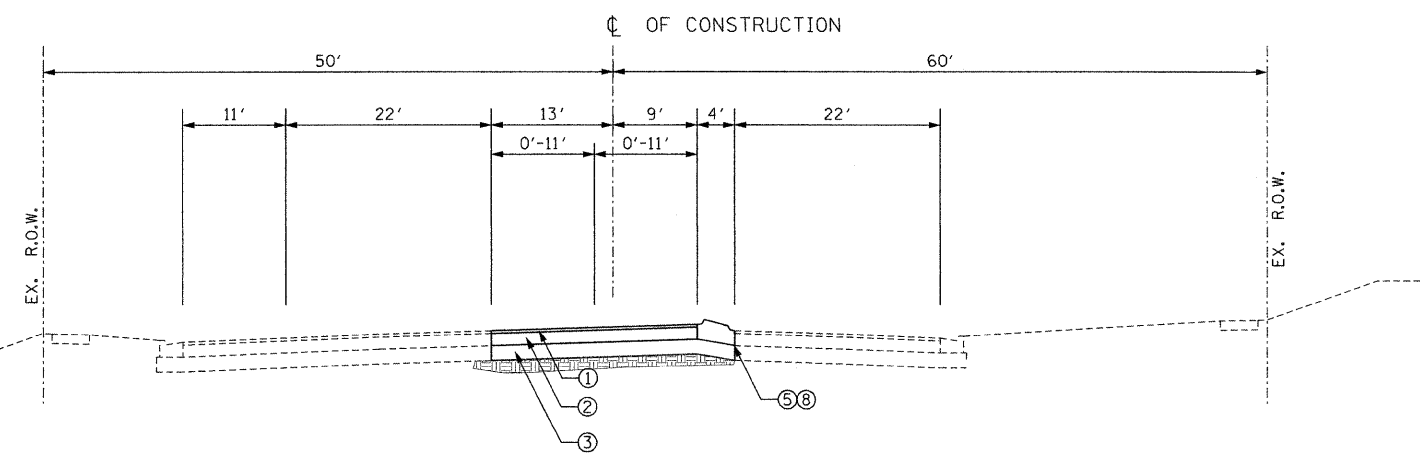

PROPOSED TYPICAL SECTION
US ROUTE 34 (EAST LEG)
STATION 114+32 TO STATION 118+94

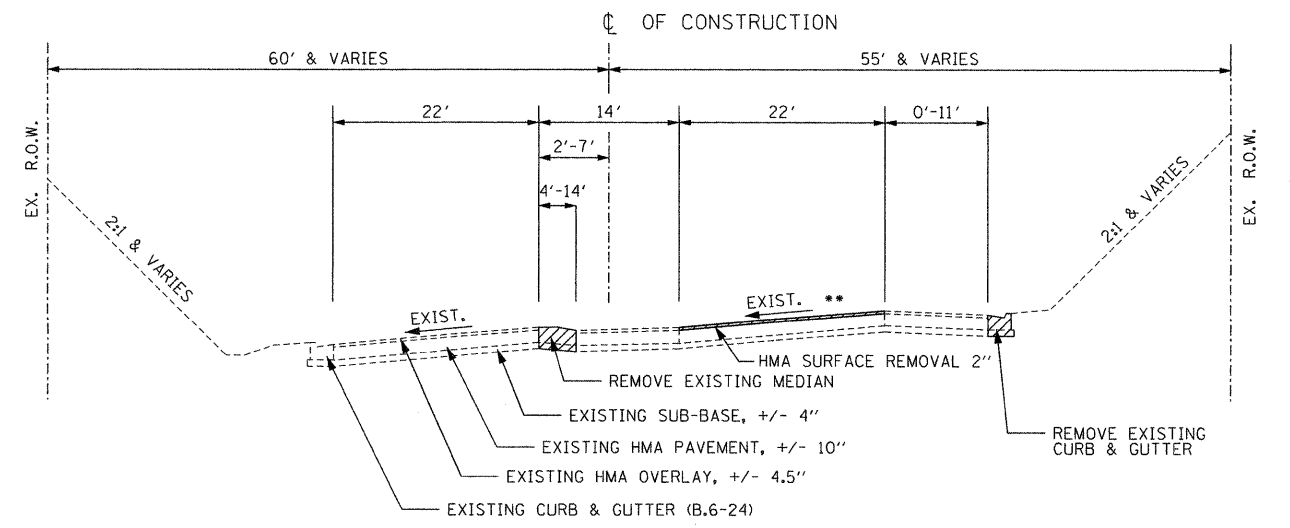

EXISTING TYPICAL SECTION
US ROUTE 34 (SOUTH LEG)
STATION 503+44 TO STATION 507+50

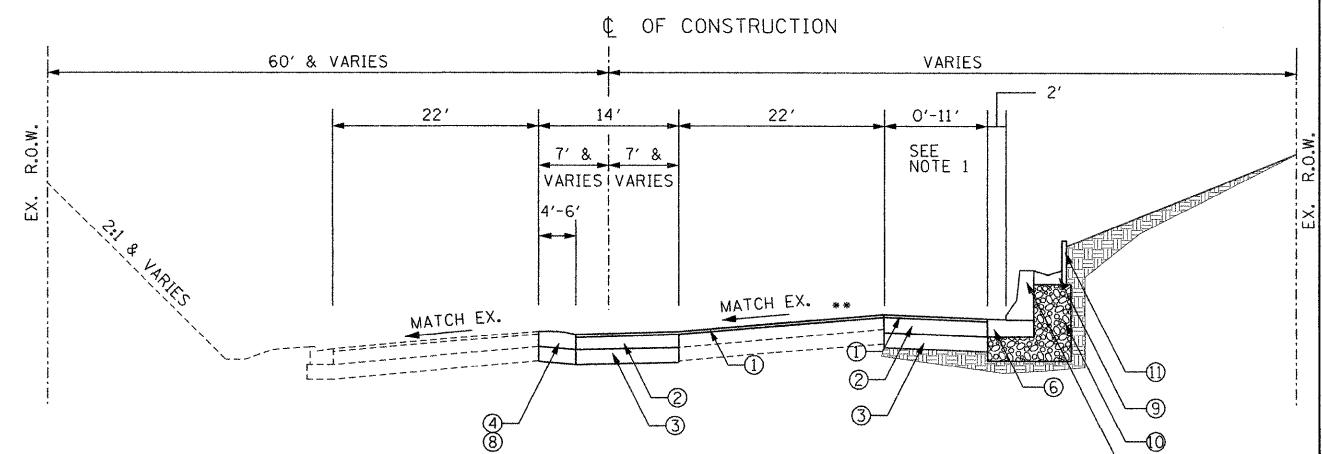

PROPOSED TYPICAL SECTION
US ROUTE 34 (SOUTH LEG)
STATION 503+44 TO STATION 507+50
** RESURFACE LIMIT STA 501+80 TO 505+85

PROPOSED LEGEND

- ① 2" POLYMERIZED HMA SURFACE COURSE MIX F, N90
- ② 10-3/4" HMA BINDER COURSE, IL 19, N90
- ③ 12" AGGREGATE SUBGRADE
- ④ CONCRETE MEDIAN, TYPE SB6.12
- ⑤ CONCRETE MEDIAN, TYPE SB6.06
- ⑥ CONCRETE BASE
- ⑦ 42" F SHAPED CONCRETE BARRIER
- ⑧ CONCRETE CORRUGATED MEDIAN
- ⑨ PAVED DITCH
- ⑩ GRANULAR BACK FILL
- ⑪ RETAINING WALL

NOTES

1. THE CONTRACTOR SHALL PERFORM THE PAVEMENT PATCHING OPERATIONS PRIOR TO THE HMA SURFACE REMOVAL OPERATION. SEE IDOT DISTRICT 1 DETAIL PAVEMENT PATCHING FOR HMA SURFACED PAVEMENT (BD-22) FOR ADDITIONAL INFORMATION.

HOT MIX ASPHALT MIXTURE REQUIREMENTS	
MIXTURE TYPE	AIR VOIDS @ Ndes
PAVEMENT RESURFACING	
HOT-MIX ASPHALT SURFACE COURSE, MIX "F", N90 (IL-9.5mm)	4% @ 90 GYR.
HOT-MIX ASPHALT BINDER COURSE, IL-19, N90	4% @ 90 GYR.
PATCHING	
CLASS D PATCHES (HMA BINDER IL-19 MM)	4% @ 70 GYR.
HMA REMOVAL OVER PATCHES (HMA BINDER IL-19MM)	4% @ 70 GYR.

MIXTURE NOTES:

1. THE UNIT WEIGHT USED TO CALCULATE ALL HOT-MIX ASPHALT SURFACE MIXTURES IS 112 LBS/SQ YD/IN
2. THE "AC TYPE" FOR POLYMERIZED HMA MIXES SHALL BE "SBS/SBR PG70-22" AND FOR NON-POLYMERIZED HMA THE "AC TYPE" SHALL BE "PG 64-22" UNLESS MODIFIED BY DISTRICT ONE SPECIAL PROVISIONS. FOR "PERCENT OF RAP" SEE DISTRICT ONE SPECIAL PROVISIONS.

FILE NAME = P:\2009\ME09006_Ver\04-Ph11\CADD\W022_US34\Shots\04-D160L22-tp.dgn
 PLOT SCALE = 1/8"=1'-0"
 USER NAME = Millennium Professional Services



200 22ND Street, Suite 216, Lombard, IL 60148
 630.785.0110 voice, 630.839.3566 fax
 www.mps-ll.com
MILLENNIA PROFESSIONAL SERVICES

DESIGNED - CJD	REVISED -
DRAWN - CJD	REVISED -
CHECKED - TVN	REVISED -
DATE - 5/31/2011	REVISED -

STATE OF ILLINOIS
DEPARTMENT OF TRANSPORTATION

US ROUTE 34
AT NORTH AURORA ROAD /RAYMOND DRIVE
 SCALE: N/A SHEET NO. 1 OF 1 SHEETS STA. TO STA.

TYPICAL SECTIONS
 SECTION 652X-N-3
 COUNTY DUPAGE
 TOTAL SHEETS 34 SHEET NO. 5
 CONTRACT NO. 60L22

F.A.P. RTE. 311	SECTION 652X-N-3	COUNTY DUPAGE	TOTAL SHEETS 34	SHEET NO. 5
FED. ROAD DIST. NO. 1 ILLINOIS FED. AID PROJECT				

P:\2009\ME09006_Ver\04-Ph11\CADD\W022_US34\Shots\04-D160L22-tp.dgn