

**CONCRETE COLLAR - STORM SEWER**  
NOT TO SCALE

NOTE: COST INCIDENTAL TO INSTALLATION OF PROPOSED PIPE

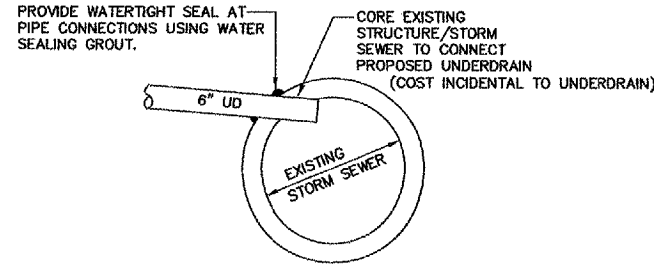
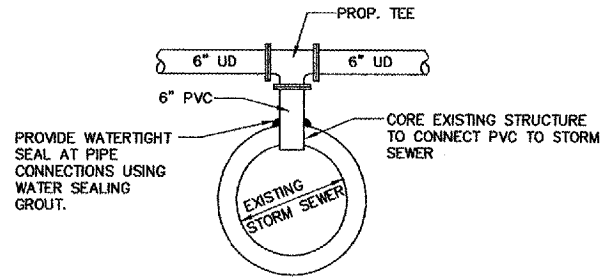

**UNDERDRAIN CONNECTION DETAILS**  
NOT TO SCALE

UNDERDRAIN CONNECTIONS AND FITTINGS, TEES AND ELBOWS USED FOR CONNECTIONS TO PROPOSED STRUCTURES AND STORM SEWERS / EXISTING STRUCTURES AND STORM SEWERS, SHALL BE CONSIDERED INCIDENTAL TO THE PROPOSED UNDERDRAIN.

INSIDE DIAMETER OF STORM SEWER (INCHES)	MAXIMUM TRENCH WIDTH
6	3'-7"
8	3'-9"
12	4'-2"
15	4'-6"
18	4'-9"
21	5'-0"
24	5'-4"
27	5'-7"
30	5'-11"
36	6'-6"
42	7'-1"
48	7'-8"
54	8'-3"
60	8'-10"
66	9'-5"
72	10'-0"
78	10'-7"
84	11'-2"
90	11'-9"
96	12'-4"
102	12'-11"
108	13'-6"

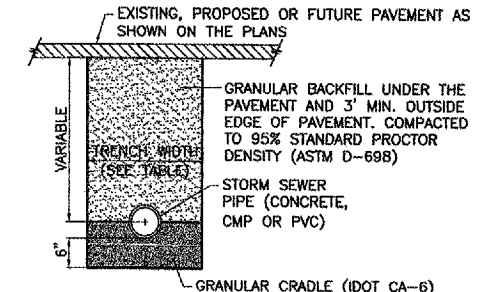

**ALL PAVED AREAS**

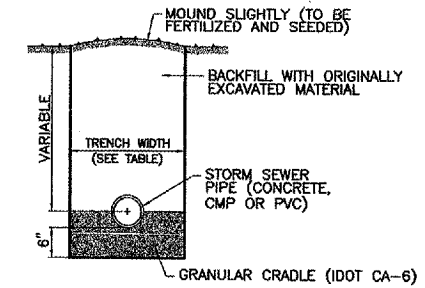

**NON-PAVED AREAS**

REVISIONS

NUMBER	BY	DATE

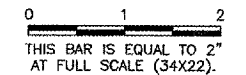

**PALWAUKEE MUNICIPAL AIRPORT**  
**WHEELING / PROSPECT HEIGHTS ILLINOIS**  
**NORTHEAST QUADRANT SITEWORK**  
**DRAINAGE DETAILS**

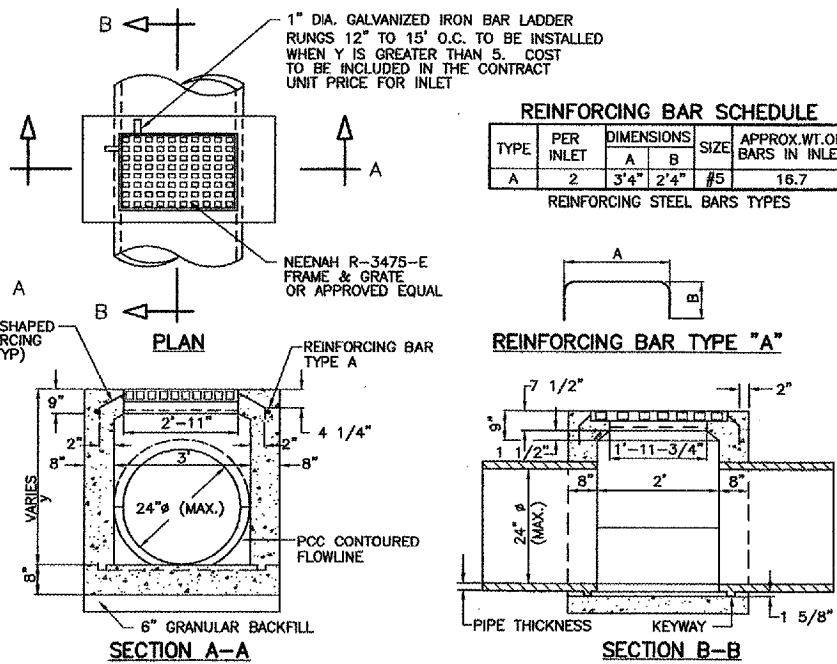

**TYPE 1 INLET**  
NOT TO SCALE

**NOTES**

- 1/2" CHAMFER TO BE USED ON ALL EXPOSED CORNERS ON INLETS. BARS TO BE INSTALLED 2" FROM FACE OF WALL.
- INLET TO BE CONSTRUCTED OF STRUCTURAL P.C. CONCRETE. THE CONTRACT UNIT PRICE FOR INLET SHALL INCLUDE THE GRATE AND FRAME AS SPECIFIED.

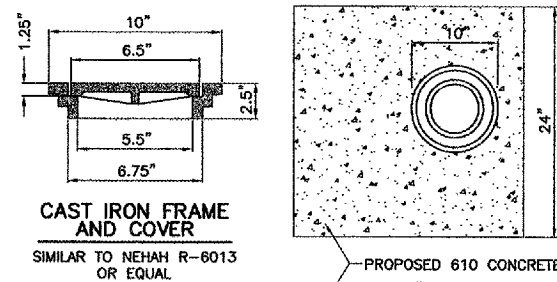

**CAST IRON FRAME AND COVER**  
SIMILAR TO NEHAH R-6013 OR EQUAL

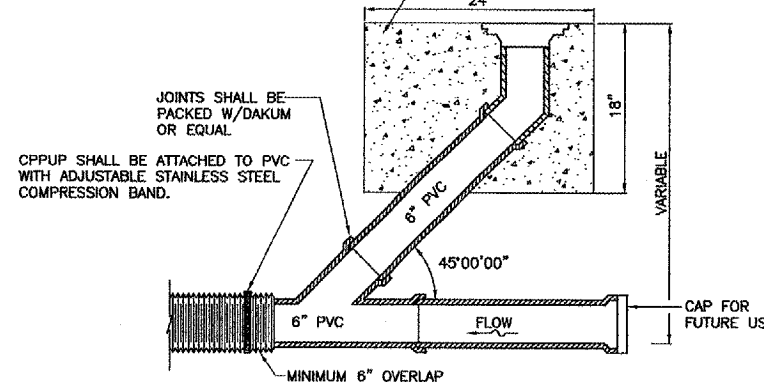

**UNDER DRAIN CLEANOUT**  
N.T.S.

NOTE:

- CONTRACTOR SHALL INSTALL UNDER DRAIN CLEANOUT STRUCTURES AT EDGE OF PAVEMENT AS SHOWN ON THE PLANS.

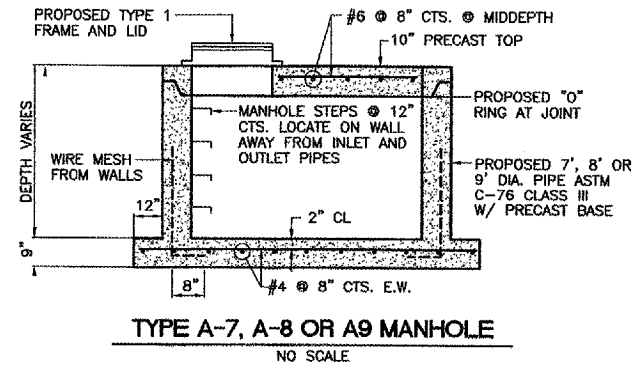

**TYPE A-7, A-8 OR A9 MANHOLE**  
NO SCALE

**STORM SEWER/UNDERDRAIN NOTES**

- CONTRACTOR SHALL FIELD VERIFY EXISTING STORM SEWER/UNDERDRAIN INVERTS BEFORE INSTALLING PROPOSED PIPE, CONNECTIONS AND ORDERING MATERIALS.
- ALL UNDERDRAIN CONNECTIONS, CORING INTO STRUCTURES, TEES, BENDS, STORM SEWER ETC. SHALL BE CONSIDERED INCIDENTAL TO THE COST OF THE UNDERDRAIN.
- UNDERDRAIN SLOPES FOLLOW EDGE OF PAVEMENT SLOPE UNLESS OTHERWISE NOTED.
- INSTALL PROPOSED ELECTRICAL DUCTS/CONDUITS TO BE CLEAR OF UNDERDRAIN, COST INCIDENTAL.
- UNDERDRAIN CONFLICTS WITH EXISTING CONDITIONS SHALL BE RESOLVED AND COST SHALL BE INCIDENTAL TO UNDERDRAIN.
- PRIOR TO ORDERING AND INSTALLING ALL FIELD TILE REPLACEMENT PIPE, THE CONTRACTOR SHALL FIELD VERIFY THE LOCATION AND INVERTS OF EXISTING FIELD TILE CONNECTIONS. ADJUSTMENTS SHALL BE MADE AS NECESSARY AT NO ADDITIONAL COST TO THE CONTRACT.
- CORING OF DRAINAGE STRUCTURE AND REMOVAL OF EXISTING STORM SEWER MANHOLE/INLET CONCRETE BENCHES TO FACILITATE CONNECTIONS OF PROPOSED STORM SEWER PIPE SHALL BE CONSIDERED INCIDENTAL TO THE COST OF THE PIPE.

© Copyright CMT, Inc.

**CMT**  
GRAYFORD MURPHY & TILLY, INC.  
CONSULTING ENGINEERS  
License No. 984-000683

**Palwaukee**  
Municipal Airport

DESIGN BY:	ARM
DRAWN BY:	JRO
CHECKED BY:	
APPROVED BY:	
DATE:	06/28/05
JOB No:	03290-02
ILLINOIS PROJECT:	PWK-3471