

THE LOCATION OF UNDERGROUND UTILITIES AS INDICATED ON THE PLANS HAS BEEN OBTAINED FROM EXISTING RECORDS. NEITHER THE OWNER NOR THE ENGINEER ASSUMES ANY RESPONSIBILITY WHATSOEVER, IN RESPECT TO THE ACCURACY OR SUFFICIENCY OF THE INFORMATION AND THERE IS NO GUARANTEE, EITHER EXPRESSED OR IMPLIED, THAT THE CONDITIONS ARE REPRESENTATIVE OF THOSE TO BE ENCOUNTERED IN THE CONSTRUCTION.

NOTE:
THE COST OF ALL TURF AND PAVEMENT DUCT MARKERS SHALL BE INCIDENTAL TO THE DUCT. THE COST OF ALL CABLE MARKERS SHALL BE INCIDENTAL TO THE CABLE.

BITUMINOUS PAVEMENT DUCT MARKER AND CONCRETE DUCT MARKER TO BE PROVIDED AT EACH END OF EACH DUCT AS SHOWN ON THE LOCATION PLAN. FOR CONCRETE PAVEMENT, THE LETTER "D" SHALL BE IMPRESSED IN THE PAVEMENT INSTEAD OF THE MARKER. THE LETTER SHALL BE INFORMED AS DESCRIBED IN NOTE 4.

CABLE MARKERS SHALL BE PLACED AT CHANGES OF DIRECTION AND EVERY 200' ALONG CABLE RUNS.

LETTERS 4" HIGH, 3" WIDE WITH WIDTH OF STROKE 1/2" AND 1/4" DEEP. ALL LETTERS, NUMBERS AND ARROWS TO BE IMPRESSED.

GENERAL NOTES
SEE LIGHTING LAYOUT SHEET FOR SIGN LEGEND, LOCATION, TYPE, SIZE, STYLE, AND CLASS.

SEE SHEETS 16 THROUGH 17 FOR ELECTRICAL NOTES

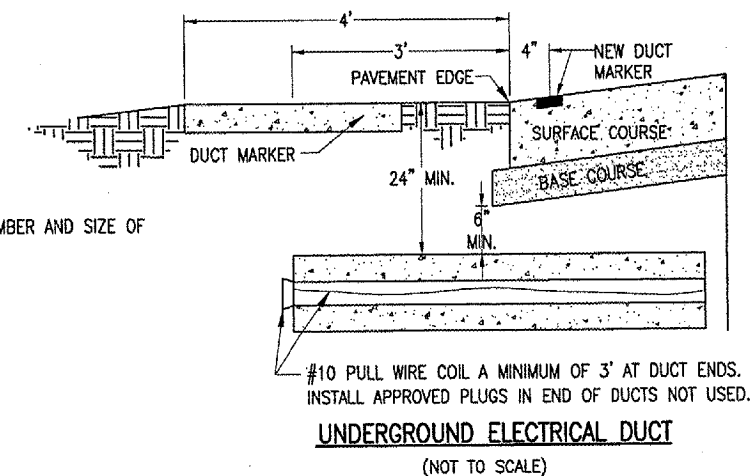
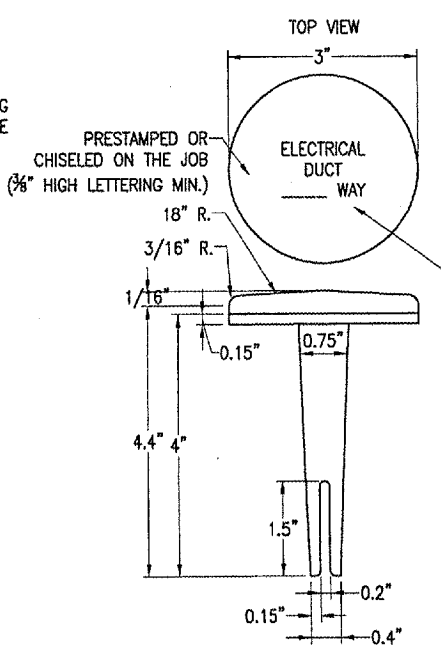
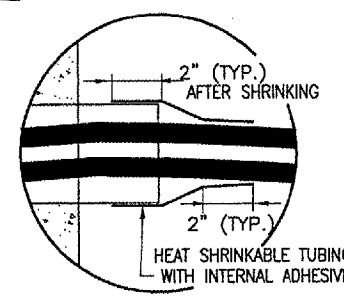
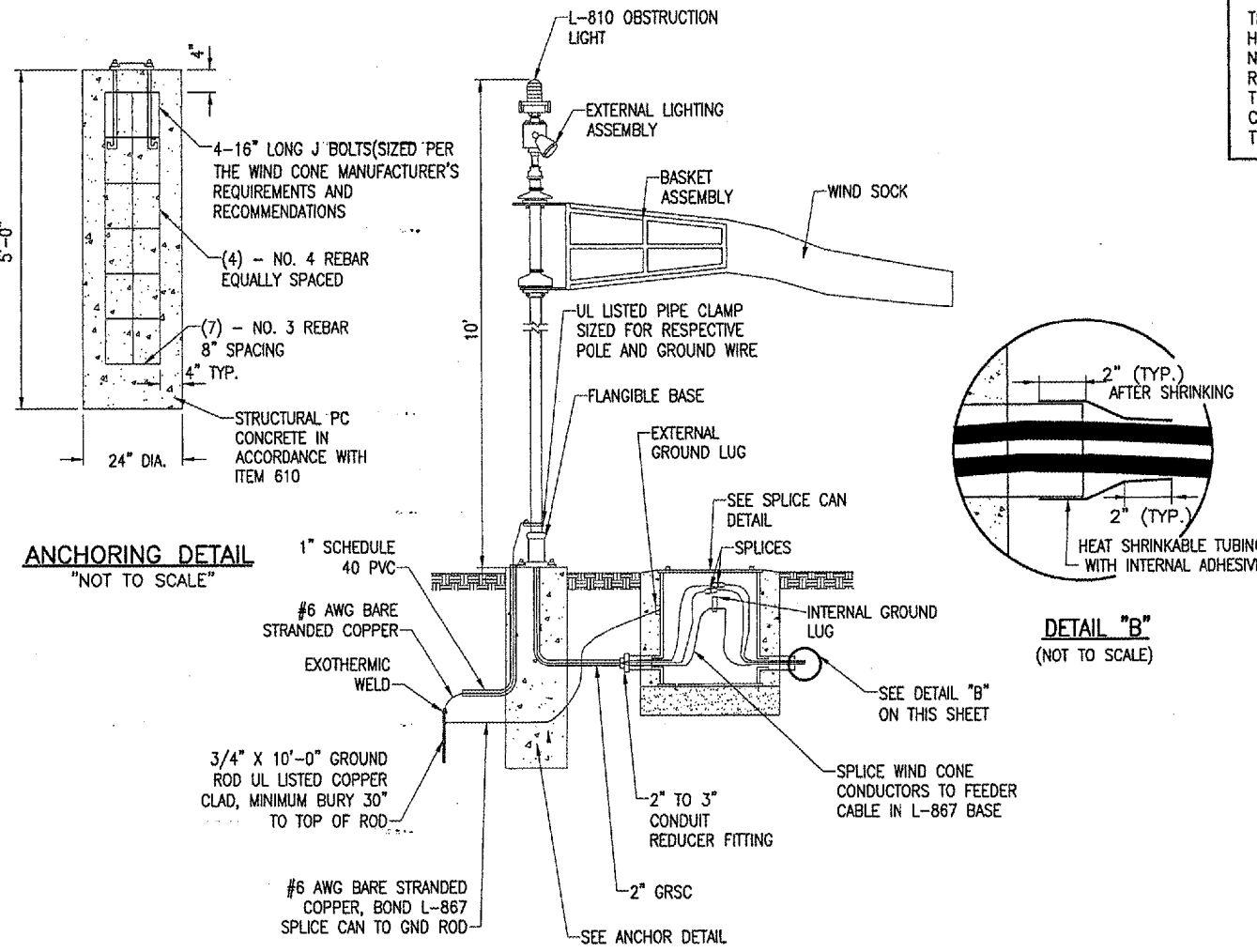

EXTERNALLY LIGHTED L806 WIND CONE
NOTE:
WIND CONE SHALL ALSO INCLUDE INTERNAL LIGHTING OPTION

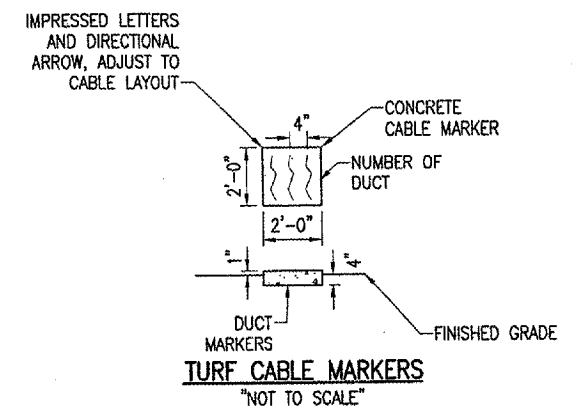
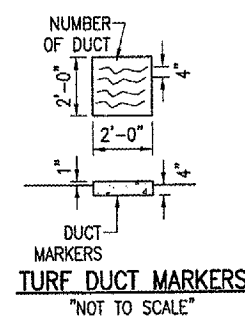
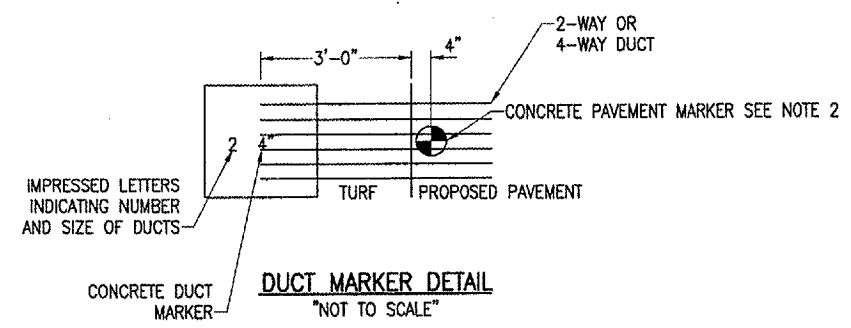
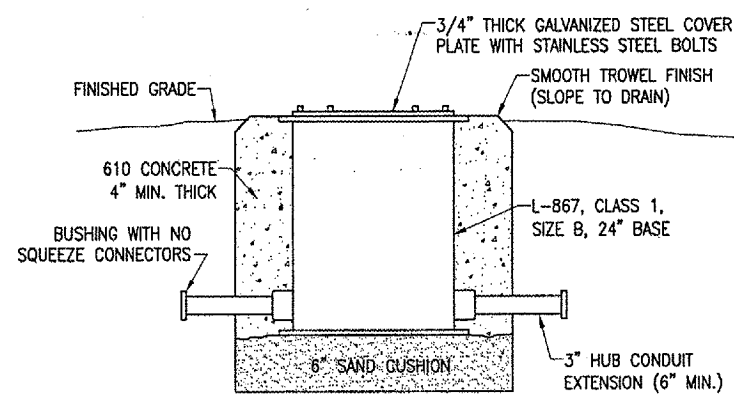

BY	
REVISION	
DATE	

DECATUR AIRPORT
DECATUR, ILLINOIS
A.L.P. PROJ.: 3-17-0033-28
I.L. PROJ.: DEC-3414

IEE Project No.	802-04TXVD
Fluorescence	R-549ELE.DWG
Scale	NONE
Date	xx/xx/xx
LAYOUT	KNL 04/22/05
DRAWN	MDR 03/11/05
REVIEWED	CAH 06/07/06

HANSON
Engineers, Architects, Scientists
1925 South State Street
Springfield, Illinois 62703-2886
Offices Nationwide

TAXIWAY G WIDENING
PHASE II
WIND CONE
ELEVATION DETAIL

JUN 10, 2005 9:47 AM CCC
F:\AIRPORTS\DECATUR\802-04TXVD\AIRPORT\ SHEETS\CONTRACT-1\R-549ELE.DWG - ELEC DETAILS