

TABLE OF DIMENSIONS

| DESIGN NO. | NOMINAL DIAM. of PIPE | SLOPE of FILL | DIMENSIONS SAME FOR ALL MULTIPLES | | | | | DIMENSIONS FOR 2 PIPES | |
|------------|-----------------------|---------------|-----------------------------------|------|----------|----------|---------|------------------------|-----------|
| | | | A | B | C | F | G | D | E |
| D375-1* | 375 | 1:1* | 495 | 260 | 590 | 750 | 940 | 1.55 m | 2.61 m |
| (D15-1*) | (15) | | (19) | (10) | (23) | (29*) | (37) | (5'-1") | (8'-6") |
| D375-2 | 375 | 1:2 | 660 | 260 | 590 | 1.0 m | 940 | 1.55 m | 2.96 m |
| (D15-2) | (15) | | (26) | (10) | (23) | (3'-3") | (37) | (5'-1") | (9'-8") |
| D450-1* | 450 | 1:1* | 495 | 330 | 660 | 750 | 1.02 m | 1.71 m | 2.77 m |
| (D18-1*) | (18) | | (19) | (13) | (26) | (29*) | (3'-4") | (5'-7") | (9'-0") |
| D450-2 | 450 | 1:2 | 660 | 330 | 660 | 1.0 m | 1.02 m | 1.71 m | 3.12 m |
| (D18-2) | (18) | | (26) | (13) | (26) | (3'-3") | (3'-4") | (5'-7") | (10'-2") |
| D600-1* | 600 | 1:1* | 640 | 410 | 840 | 965 | 1.22 m | 2.11 m | 3.47 m |
| (D24-1*) | (24) | | (25) | (16) | (33) | (38) | (4'-0") | (6'-11") | (11'-4") |
| D600-2 | 600 | 1:2 | 860 | 410 | 840 | 1.28 m | 1.22 m | 2.11 m | 3.92 m |
| (D24-2) | (24) | | (34) | (16) | (33) | (4'-2") | (4'-0") | (6'-11") | (12'-10") |
| D750-1* | 750 | 1:1* | 760 | 485 | 990 | 1.14 m | 1.37 m | 2.41 m | 4.02 m |
| (D30-1*) | (30) | | (30) | (19) | (39) | (3'-9") | (4'-6") | (7'-11") | (13'-2") |
| D750-2 | 750 | 1:2 | 1.01 m | 485 | 990 | 1.5 m | 1.37 m | 2.41 m | 4.53 m |
| (D30-2) | (30) | | (3'-4") | (19) | (39) | (4'-11") | (4'-6") | (7'-11") | (14'-10") |
| D900-1* | 900 | 1:1* | 915 | 560 | 1.17 m | 1.36 m | 1.57 m | 2.75 m | 4.67 m |
| (D36-1*) | (36) | | (36) | (22) | (3'-10") | (4'-5") | (5'-2") | (9'-0") | (15'-6") |
| D900-2 | 900 | 1:2 | 1.22 m | 560 | 1.17 m | 1.79 m | 1.57 m | 2.75 m | 5.28 m |
| (D36-2) | (36) | | (4'-0") | (22) | (3'-10") | (5'-10") | (5'-2") | (9'-0") | (17'-6") |

DIMENSIONS FOR No. 15 BARS-h to h₉ (No. 4) BARS-h to h₉

| MARK | 2 PIPES | |
|----------------|----------------|-----------------|
| | a | b |
| h | 1.5 m (4'-11") | 740 (29) |
| h ₁ | 1.5 m (4'-11") | 1.0 m (3'-3") |
| h ₂ | 1.65 m (5'-5") | 740 (29) |
| h ₃ | 1.65 m (5'-5") | 1.0 m (3'-3") |
| h ₄ | 2.06 m (6'-9") | 990 (39) |
| h ₅ | 2.06 m (6'-9") | 1.3 m (4'-3") |
| h ₆ | 2.36 m (7'-9") | 1.18 m (3'-10") |
| h ₇ | 2.36 m (7'-9") | 1.49 m (4'-10") |
| h ₈ | 2.75 m (9'-0") | 1.45 m (4'-9") |
| h ₉ | 2.75 m (9'-0") | 1.75 m (5'-9") |

NOTE: THE DESIGN FOR THE HEADWALLS ARE:
TWIN 24" PIPES - D24-2
TWIN 36" PIPES - D36-2

TABLE OF QUANTITIES

| DESIGN NO. | Concrete 2 End Secs. cu. m (cu. yds.) | REINFORCEMENT BARS IN ONE END SECTION | | | | | | | | | | TOTAL Qty. 2 End Secs. kg (lbs.) | | |
|------------------|---------------------------------------|---------------------------------------|-----------------|--|-----------------|--|-----------------|------------------------------|----------------|--|----------------|----------------------------------|------------------------------|--------|
| | | No. 15-h Bars (No. 4)-h Bars | | No. 15-b ₂ Bars (No. 4)-b ₂ Bars | | No. 15-b ₁ Bars (No. 4)-b ₁ Bars | | No. 15-b Bars (No. 4)-b Bars | | No. 15-v ₁ Bars (No. 4)-v ₁ Bars | | | No. 15-v Bars (No. 4)-v Bars | |
| | | MARK | LENGTH | QTY. | LENGTH | QTY. | LENGTH | QTY. | LENGTH | QTY. | LENGTH | | QTY. | LENGTH |
| D375-1* (D15-1*) | 1.1 (1.4) | h | 2.98 m (9'-9") | 2 | 2.5 m (8'-3") | | | 1 | 1.9 m (6'-3") | | | 14 | 70 (100) | |
| D375-2 (D15-2) | 1.4 (1.8) | h ₁ | 3.5 m (11'-6") | 2 | 2.82 m (9'-3") | 1 | 2.21 m (7'-3") | 1 | 1.9 m (6'-3") | | | 17 | 90 (130) | |
| D450-1* (D18-1*) | 1.3 (1.7) | h ₂ | 3.13 m (10'-3") | 2 | 2.59 m (8'-6") | | | 1 | 2.06 m (6'-9") | | | 14 | 70 (100) | |
| D450-2 (D18-2) | 1.5 (2.0) | h ₃ | 3.65 m (12'-0") | 2 | 2.97 m (9'-9") | 1 | 2.36 m (7'-9") | 1 | 2.06 m (6'-9") | | | 17 | 90 (130) | |
| D600-1* (D24-1*) | 1.8 (2.4) | h ₄ | 4.04 m (13'-3") | 2 | 3.35 m (11'-0") | 1 | 2.74 m (9'-0") | 1 | 2.44 m (8'-0") | 4 | 790 (31) | 18 | 110 (160) | |
| D600-2 (D24-2) | 2.3 (3.0) | h ₅ | 4.66 m (15'-3") | 2 | 3.81 m (12'-6") | 1 | 3.2 m (10'-6") | 1 | 2.44 m (8'-0") | 4 | 790 (31) | 21 | 130 (180) | |
| D750-1* (D30-1*) | 2.3 (3.0) | h ₆ | 4.72 m (15'-6") | 2 | 3.89 m (12'-9") | 1 | 3.12 m (10'-3") | 1 | 2.51 m (8'-3") | 4 | 790 (31) | 19 | 120 (170) | |
| D750-2 (D30-2) | 2.9 (3.8) | h ₇ | 5.34 m (17'-6") | 2 | 4.42 m (14'-6") | 1 | 3.73 m (12'-3") | 1 | 2.51 m (8'-3") | 4 | 790 (31) | 22 | 140 (190) | |
| D900-1* (D36-1*) | 3.0 (3.9) | h ₈ | 5.65 m (18'-6") | 2 | 4.57 m (15'-0") | 1 | 3.81 m (12'-6") | 1 | 2.97 m (9'-9") | 4 | 1,07 m (3'-6") | 22 | 150 (200) | |
| D900-2 (D36-2) | 3.8 (5.0) | h ₉ | 6.25 m (20'-6") | 2 | 5.18 m (17'-0") | 1 | 4.42 m (14'-6") | 1 | 2.97 m (9'-9") | 4 | 1,07 m (3'-6") | 26 | 170 (230) | |

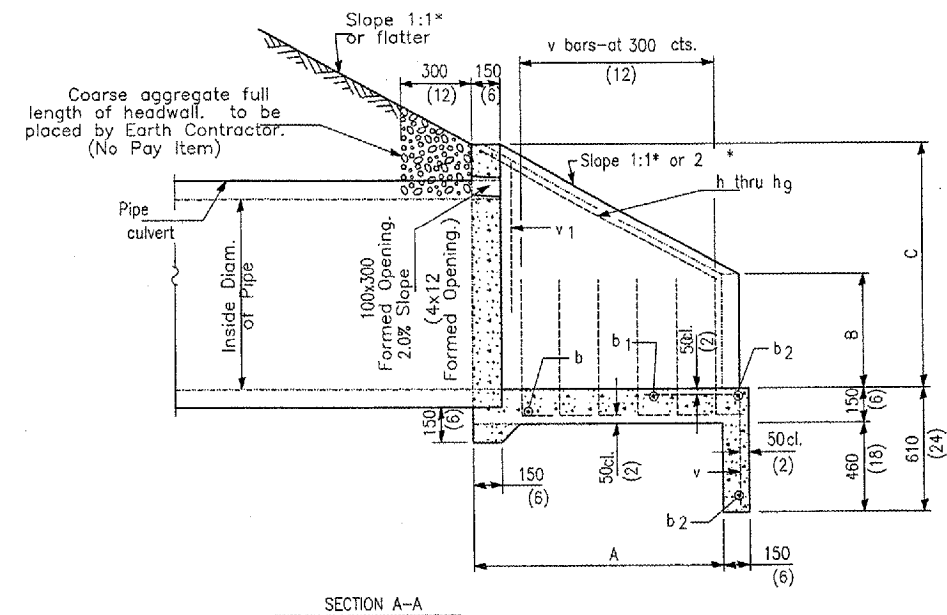
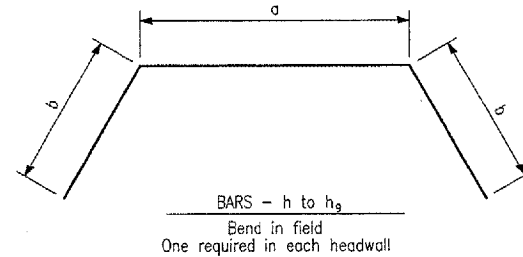
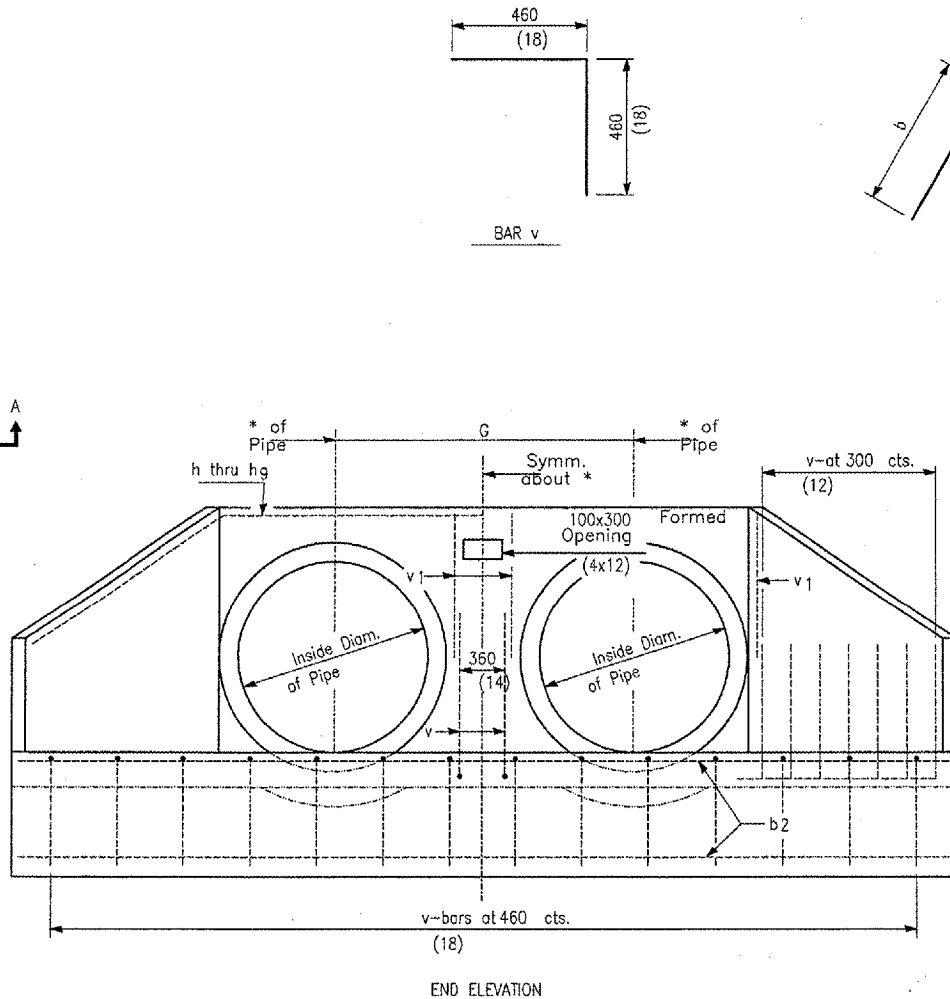
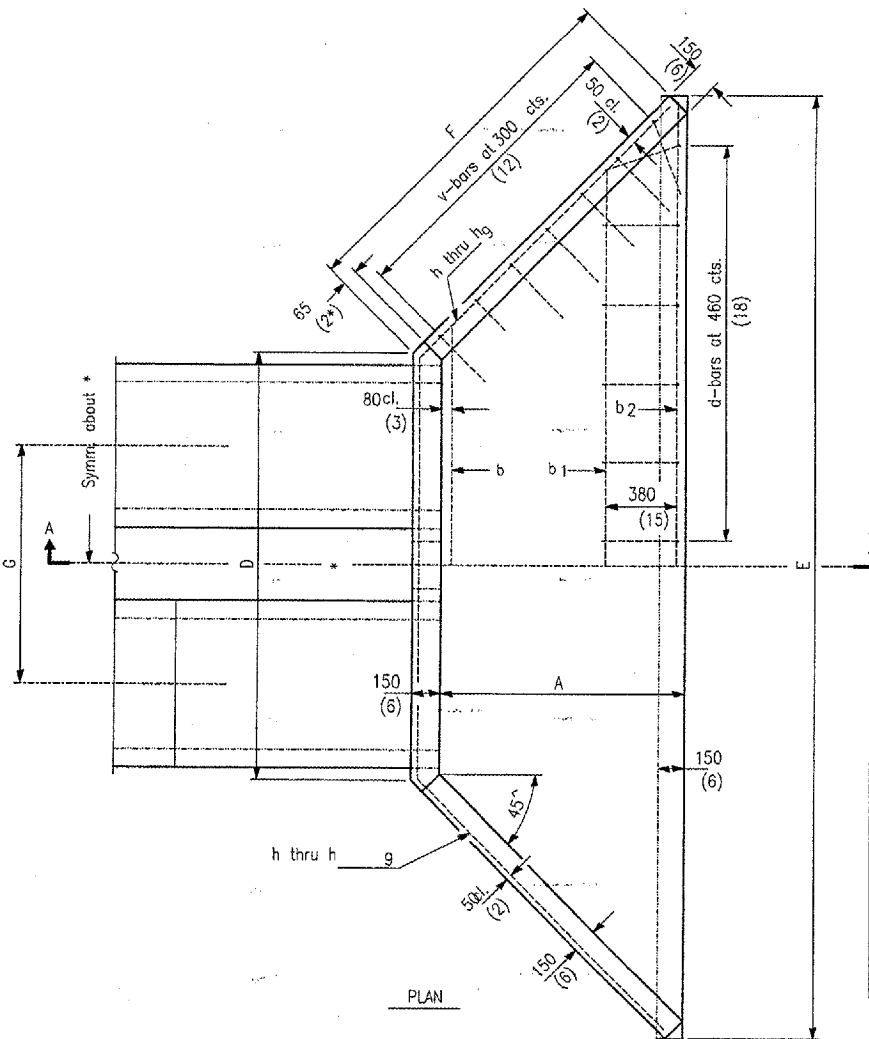

JUN 10, 2005 9:44 AM CCC
E:\AIRPORTS\DECATUR\802-04TXD\AIRPORT SHEETS\CONTRACT-1\R-531DRN.DWG - Details 2

| BY | REVISION | DATE |
|----|----------|------|
| | | |
| | | |



| | | |
|-----------------------|-----|----------|
| Project No. 802-04TXD | CCC | 03/18/05 |
| Revision R-531DRN.DWG | CCC | 03/18/05 |
| Scale N/A | WJM | 06/07/05 |
| Date 03/18/05 | | |

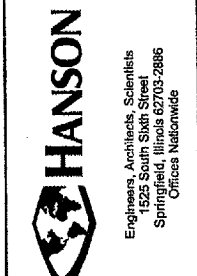

TAXIWAY G WIDENING
PHASE II
DRAINAGE DETAILS

IL PROJ: DEC-3414 A.I.P. PROJ: 3-17-0033-28