

F.A.P. RTE.	SECTION	COUNTY	TOTAL SHEETS	SHEET NO.
307	541X-I	COOK	7	4

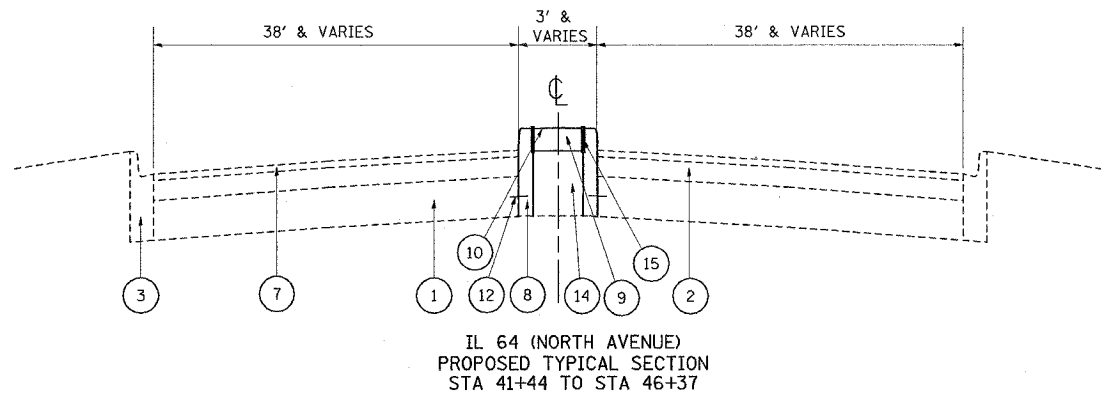
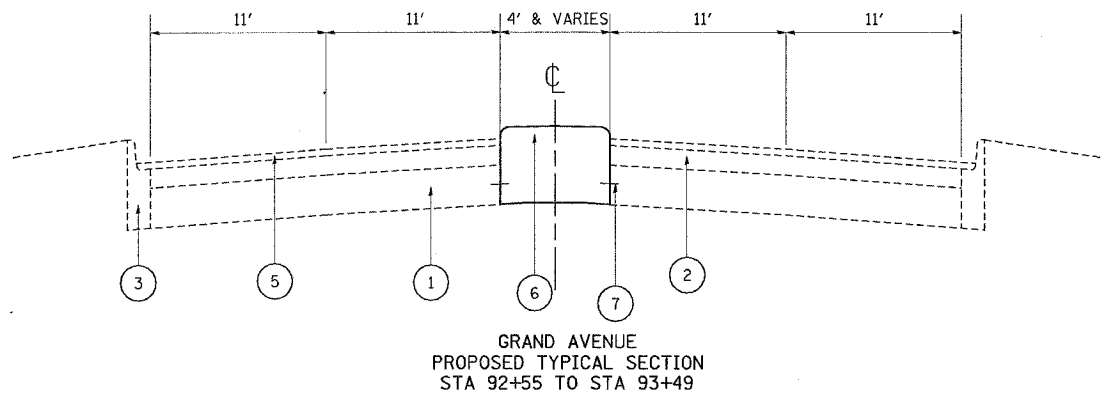
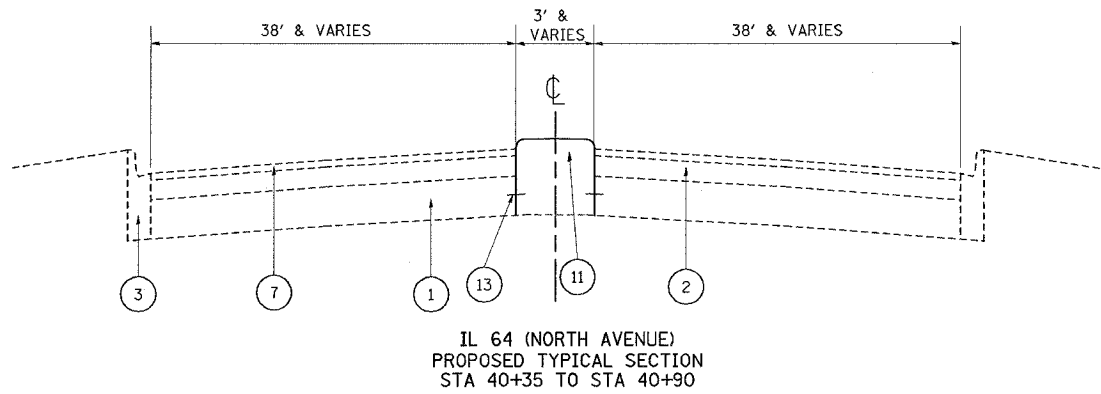
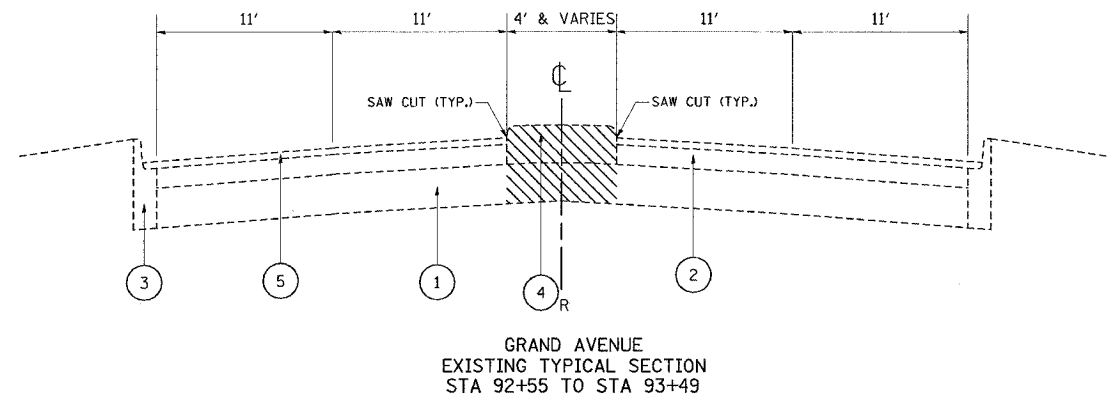
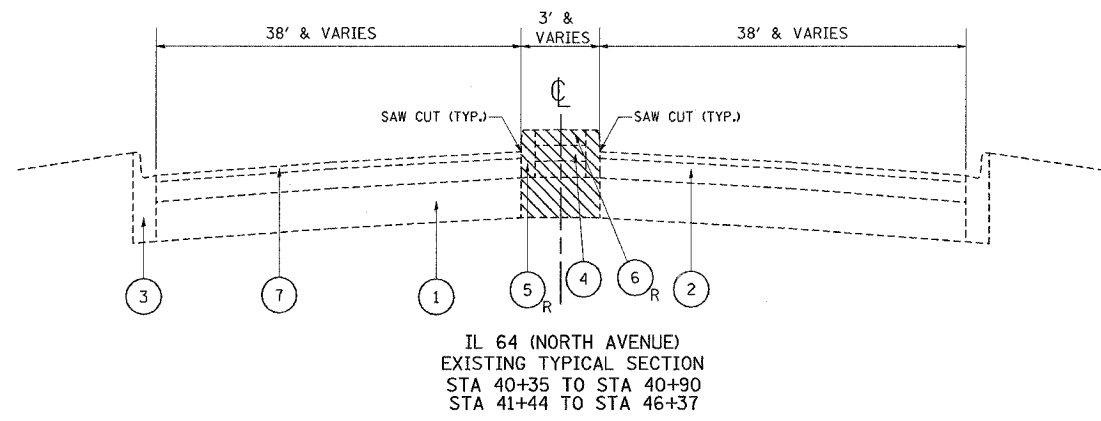

LEGEND

- ① EXIST. PCC PAVEMENT
 - ② EXIST. RESURFACING
 - ③ EXIST. COMB. CONCRETE CURB AND GUTTER, TYPE B-6.J2
 - ④ EXIST. CORRUGATED MEDIAN
 - ⑤ EXIST. BITUMINOUS SURFACE COURSE, MIX "D", CLASS 1, TYPE 2, 1 1/2"
 - ⑥ PROP. CORRUGATED MEDIAN
 - ⑦ PROP. DRILL AND GROUT #6 TIE BAR (24" C-C), COST INCLUDED IN CORRUGATED MEDIAN PAY ITEM
- R - DESIGNATED FOR REMOVAL

LEGEND

- ① EXIST. PCC PAVEMENT
 - ② EXIST. RESURFACING
 - ③ EXIST. COMB. CONCRETE CURB AND GUTTER, TYPE B-6.J2
 - ④ EXIST. CRUSHED STONE
 - ⑤ EXIST. PC CONCRETE CURB
 - ⑥ EXIST. PC CONCRETE MEDIAN SURFACE, 2 1/2"
 - ⑦ EXIST. BITUMINOUS SURFACE COURSE, MIX "E", CLASS 1, TYPE 2, 2 1/4"
 - ⑧ PROP. CONCRETE CURB, TYPE B
 - ⑨ PROP. CONCRETE MEDIAN SURFACE, 4"
 - ⑩ PROP. CONCRETE MEDIAN SURF, (STAMPING)
 - ⑪ PROP. CORRUGATED MEDIAN
 - ⑫ PROP. DRILL AND GROUT #4 TIE BAR, 90° SHAPE (24" C-C), COST INCLUDED IN CONCRETE CURB, TYPE B PAY ITEM
 - ⑬ PROP. DRILL AND GROUT #6 TIE BAR (24" C-C), COST INCLUDED IN CORRUGATED MEDIAN PAY ITEM
 - ⑭ PROP. COARSE AGGREGATE - FILL TO SUBGRADE (TYP.) COST INCLUDED IN CONC. MEDIAN SURFACE, 4 INCH PAY ITEM
 - ⑮ PROP. 5/8" PREFORMED EXPANSION JOINT FILLER - COST INCLUDED IN CONCRETE CURB, TYPE B PAY ITEM
- R - DESIGNATED FOR REMOVAL

REVISIONS	
NAME	DATE

ILLINOIS DEPARTMENT OF TRANSPORTATION

IL 64/GRAND AVE.
EXISTING AND PROPOSED
TYPICAL SECTIONS

SCALE: VERT. NONE
DATE: HORIZ.

DRAWN BY
CHECKED BY **R2**