

FAU NO.	SECTION	COUNTY	TOTAL SHEETS	SHEET NO.
3578	1314 RS-3	COOK	23	15
STA.	TO STA.			
FED. ROAD DIST. NO.	ILLINOIS	FED. AID PROJECT		

62673

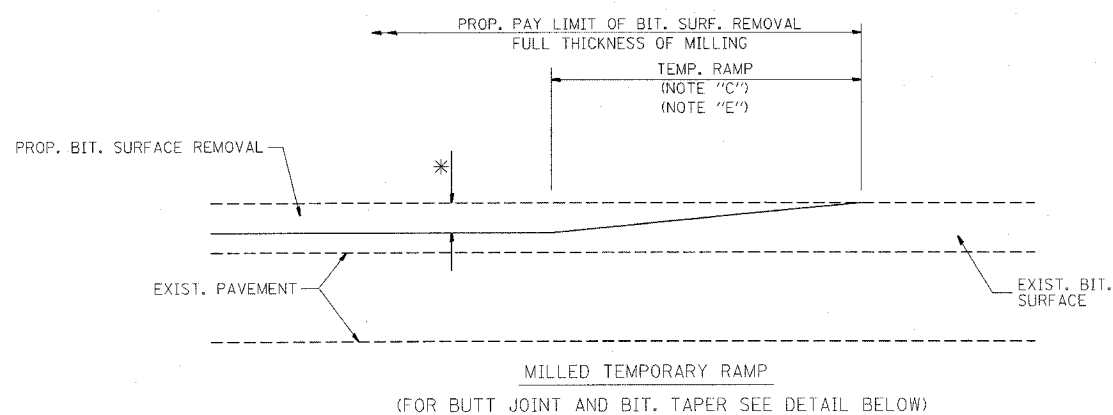

OPTION 1

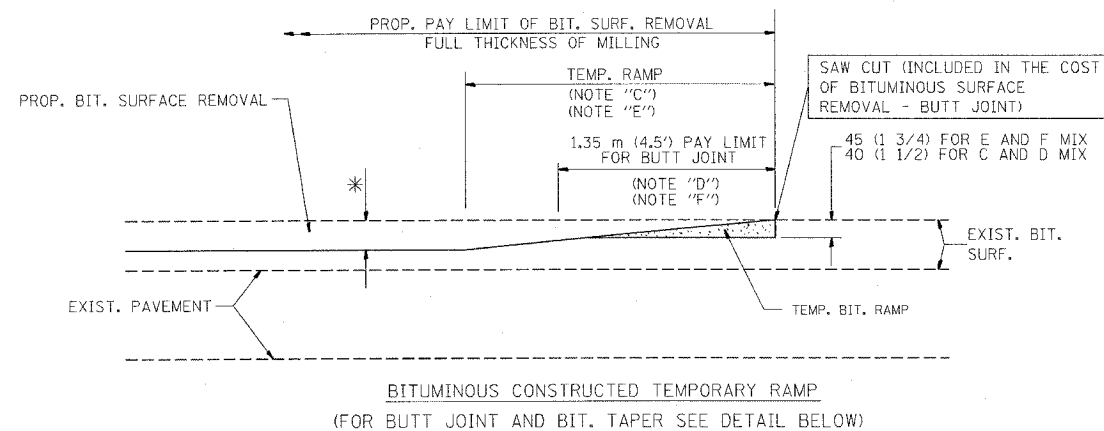

OPTION 2
TYPICAL TEMPORARY RAMP

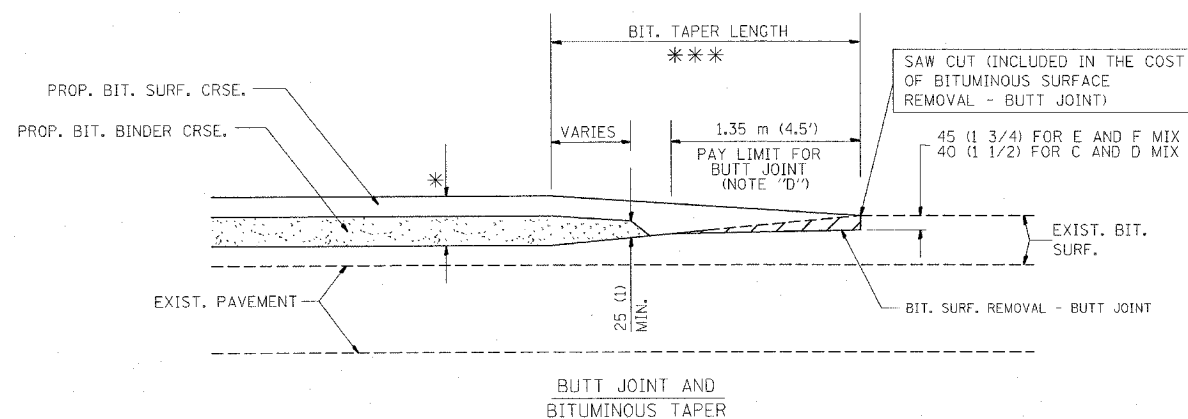

TYPICAL BUTT JOINT AND BITUMINOUS TAPER
FOR MILLING AND RESURFACING

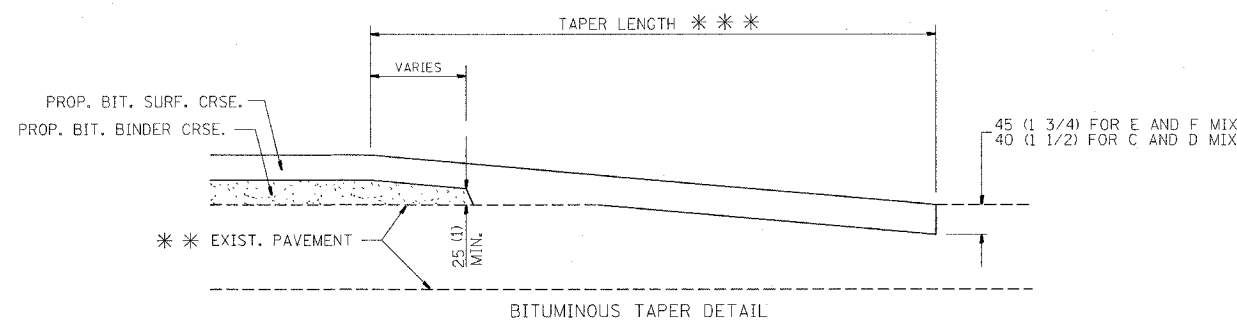
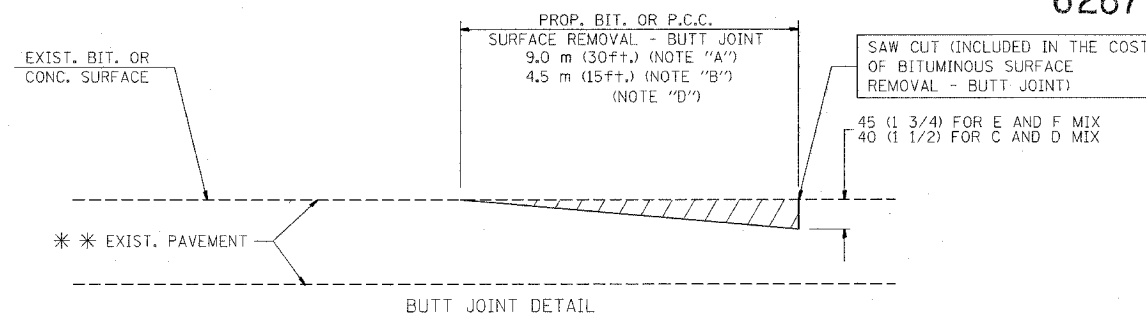

TYPICAL BUTT JOINT AND BITUMINOUS TAPER
FOR RESURFACING ONLY

** PC CONCRETE, BITUMINOUS OR BITUMINOUS RESURFACED PAVEMENT.

NOTES

- A: MAINLINE ROADWAYS AND MAJOR SIDE ROADS.
- B: MINOR SIDE ROADS.
- C: THE TEMP. RAMP SHALL BE CONSTRUCTED IMMEDIATELY UPON REMOVAL OF THE EXISTING BITUMINOUS SURFACE.
- D: THE BUTT JOINT SHALL BE CONSTRUCTED IMMEDIATELY PRIOR TO PLACING THE PROPOSED BITUMINOUS COURSES.
- E: TAPER THE TEMP. RAMP AT A RATE OF 900 (3 FT.) PER INCH OF MILLING THICKNESS.
- F: INSTALLATION AND REMOVAL OF THE 1.35 m (4.5') TEMP. BIT. RAMP WILL BE PAID AS "BITUMINOUS SURFACE REMOVAL - BUTT JOINT".
- G: SEE ARTICLE 406.18 AND 406.24 OF THE STANDARD SPECIFICATIONS FOR "BITUMINOUS AND PCC SURFACE REMOVAL, BUTT JOINT".
- * SEE TYPICAL SECTIONS FOR MILLING THICKNESS.
- ** 6.1 m (20') PER 25 (1) RESURFACING (NOTE 'A')
3.0 m (10') PER 25 (1) RESURFACING (NOTE 'B')

ALL DIMENSIONS ARE IN MILLIMETERS (INCHES) UNLESS OTHERWISE SHOWN.

BASIS OF PAYMENT:

THE BUTT JOINT WILL BE PAID FOR PER SQUARE METER (SQUARE YARD.) AS "BITUMINOUS SURFACE REMOVAL - BUTT JOINT" OR AS "PORTLAND CEMENT CONCRETE SURFACE REMOVAL - BUTT JOINT".

REVISIONS	
NAME	DATE
M. DE YONG	6-13-90
M. DE YONG	7-3-90
M. DE YONG	3-27-92
R. SHAH	09/09/94
R. SHAH	10/25/94
A. ABBAS	03/21/97
M. GOMEZ	04/06/01

ILLINOIS DEPARTMENT OF TRANSPORTATION

BUTT JOINT AND
BITUMINOUS TAPER
DETAILS

SCALE: NONE
DATE PLOTTED: 3/28/2005

DRAWN BY
CHECKED BY
BD400-05 (VI-BD32)
REVISION DATE: 04/06/01