

F.A.D. RTE.	SECTION	COUNTY	TOTAL SHEETS	SHEET NO.
3578	1314 RS-3	COOK	23	4
STA.		TO STA.		
FED. ROAD DIST. NO. 1 ILLINOIS		FED. AID PROJECT		

CONTRACT 62673

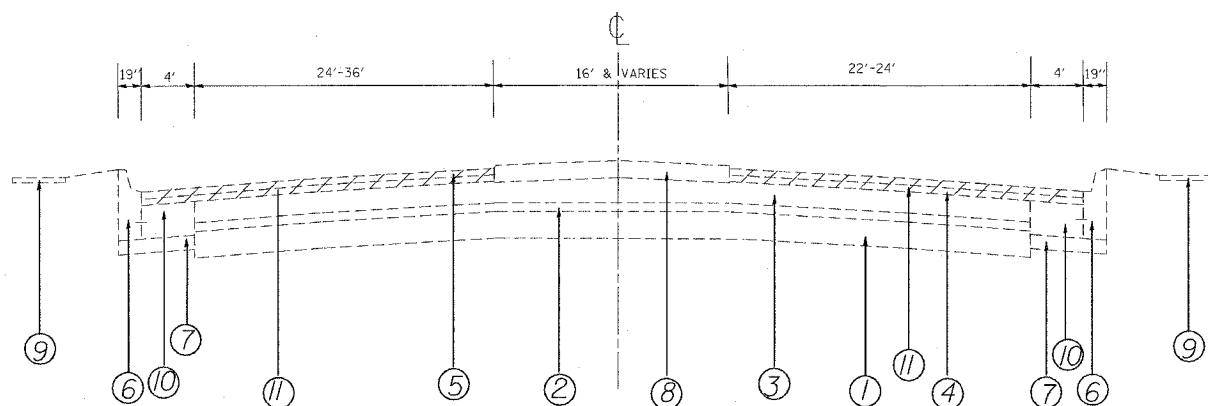

EXISTING TYPICAL CROSS-SECTION
SOUTHWEST HWY

STA 22+50 TO STA 83+40

NOTE: B-6.12 CURB & GUTTER ENDS AT STA 83+46
B-6.24 CURB & GUTTER BEGINS AT STA 83+46

LEGEND

- ① EXISTING PCC PAVEMENT (9'-7")
- ② EXISTING BITUMINOUS RESURFACING +- 3"
- ③ EXISTING BITUMINOUS AGGREGATE MIXTURE (6" OVERLAY)
- ④ EXISTING BITUMINOUS CONCRETE BINDER COURSE (1 1/2")
- ⑤ EXISTING BITUMINOUS CONCRETE SURFACE COURSE CLASS 1 (1 1/2")
- ⑥ EXISTING COMBINATION CURB AND GUTTER TYPE B-6J2
- ⑦ EXISTING SUB-BASE GRANULAR MATERIAL, TYPE A (6")
- ⑧ EXISTING CORRUGATED MEDIAN
- ⑨ EXISTING PCC SIDEWALK
- ⑩ EXISTING PCC BASE COURSE WIDENING (9")
- ⑪ PROPOSED BITUMINOUS SURFACE REMOVAL, (2 1/2")
- ⑫ PROPOSED POLYMERIZED LEVELING BINDER (MACHINE METHOD) SUPERPAVE, IL-475, N50 (3/4")
- ⑬ PROPOSED POLYMERIZED BIT. CONCRETE SURFACE COURSE, SUPERPAVE, MIX "F", N90 (1 3/4")

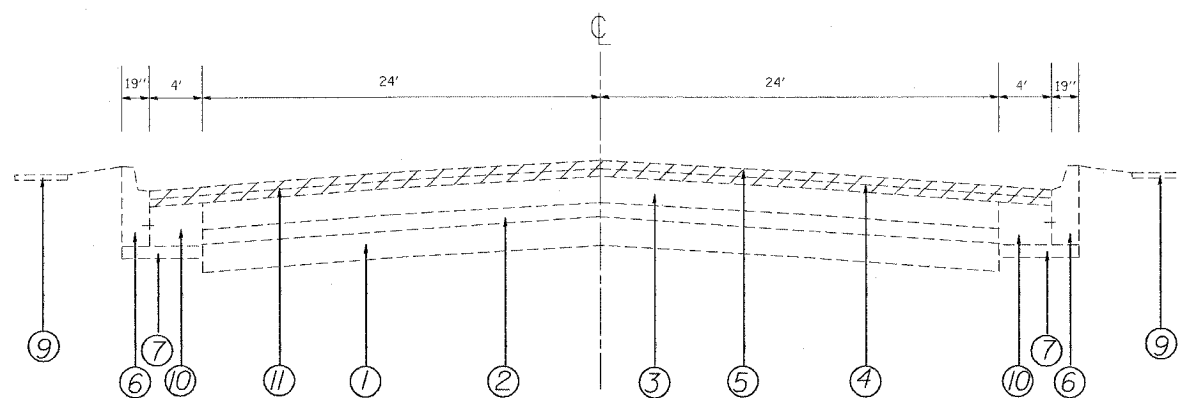

EXISTING TYPICAL CROSS-SECTION
SOUTHWEST HWY

STA 83+40 TO STA 84+08

REVISIONS		ILLINOIS DEPARTMENT OF TRANSPORTATION
NAME	DATE	
		TYPICAL SECTIONS

SCALE: VERT. NTS
HORIZ. NTS
DATE 3/28/2005

DRAWN BY
CHECKED BY