

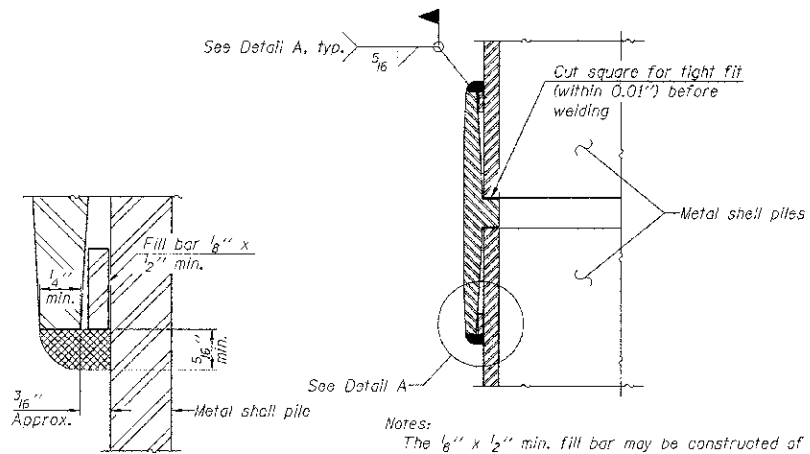

METAL SHELL PILE TABLE

Designation and outside diameter	Wall thickness t	Weight per foot (Lbs./ft.)	Inside volume (yd. ³ /ft.)
PP12	0.179"	22.60	0.0274
PP12	0.250"	31.37	0.0267
PP14	0.250"	36.71	0.0368
PP14	0.312"	45.61	0.0361



DETAIL A

WELDED COMMERCIAL SPLICE

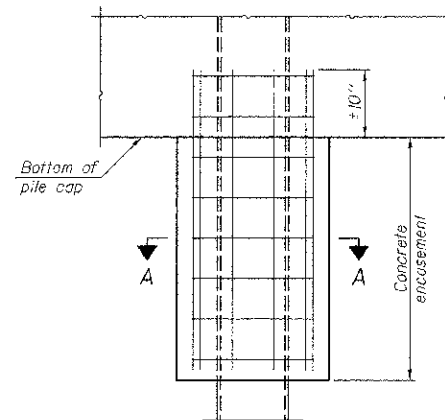

ELEVATION

CONCRETE ENCASEMENT AT PIERS

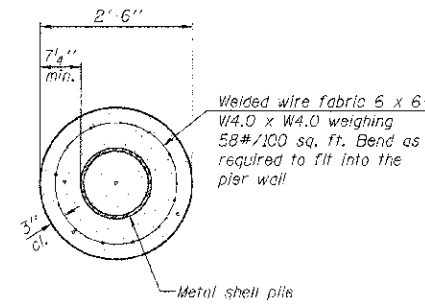

SECTION A-A

Note: Forms for encasement may be omitted when soil conditions permit.

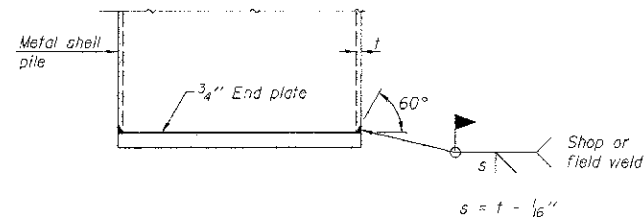

END PLATE ATTACHMENT

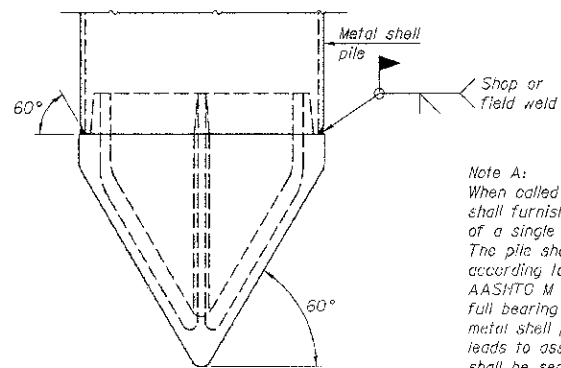

METAL SHELL PILE SHOE ATTACHMENT

(See Note A)

Note A: When called for on the plans, the Contractor shall furnish metal shell pile shoes consisting of a single piece conical pile point as shown. The pile shoes shall be cast in one piece steel according to either ASTM A 148 Grade 90-60 or AASHTO M 103 Grade 65-35 and shall provide full bearing over the full circumference of the metal shell pile. The pile shoe shall have tapered leads to assure proper alignment and fitting and shall be secured to the pile with a circumferential weld.

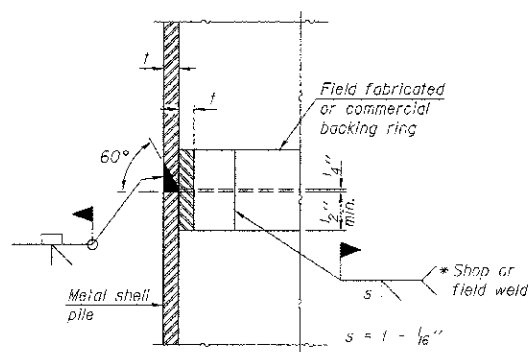

COMPLETE PENETRATION WELD SPLICE

* Field fabricated backing ring may be made from pile shell by removing segment to allow reducing circumference and vertically rejoin with partial joint penetration weld.

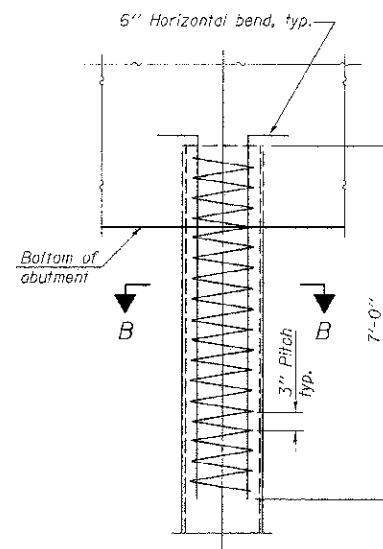

ELEVATION

METAL SHELL REINFORCEMENT AT ABUTMENTS

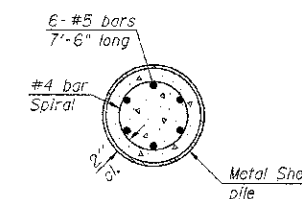

SECTION B-B

Note: The metal shell piles shall be according to ASTM A 252 Grade 3.

METAL SHELL PILE DETAILS			
Date	Designed MJP	T.R. 56 OVER UNNAMED DRAINAGE DITCH SECTION 05-07161-00-BR MACON COUNTY STA. 15+05.80 PROP. STR. NO. 058-3382	Sheet No.
Revisions	Drawn BKN		6
	Checked KWB		
	Approved KWB		
Prepared by: URS	345 East Ash Avenue Decatur, IL 62526	URS Job No. 36431683	of 6