

**FABRIC BEARING PAD**  
(Interior)

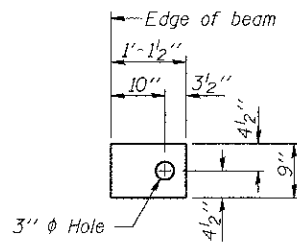

**FABRIC BEARING PAD**  
(Exterior)

**FIXED**

Notes:  
All bearing pads shall be 1" thick.  
Omit holes when using expansion bearings.  
Expansion bearing pad shall be bonded to the substructure.

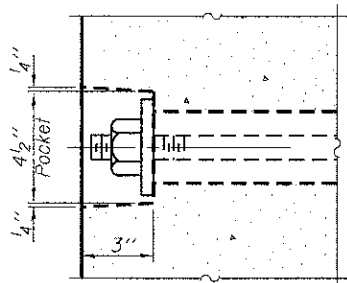

**SECTION A-A**

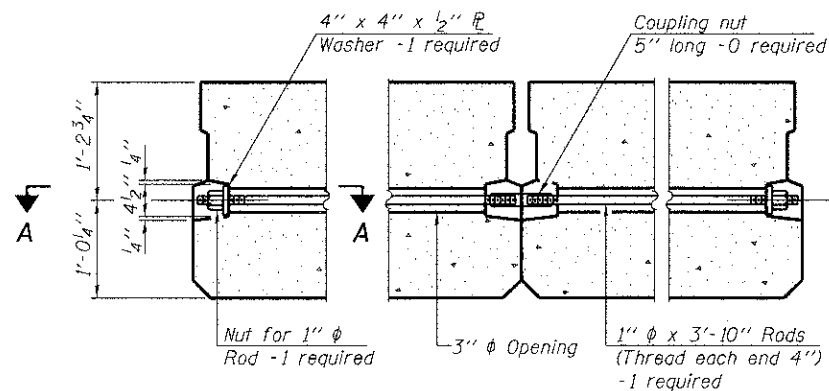

**TYPICAL TRANSVERSE TIE ASSEMBLY**

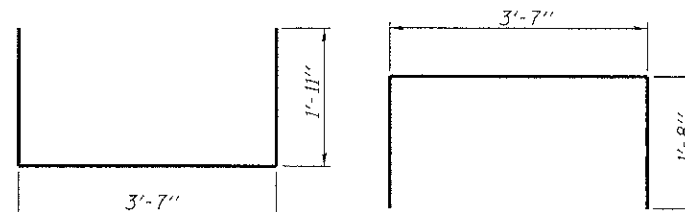

**BAR S1(E)**

**BAR S2(E)**

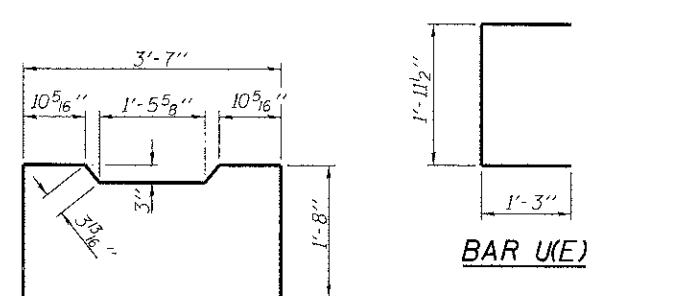

**BAR U1(E)**

**BAR U2(E)**

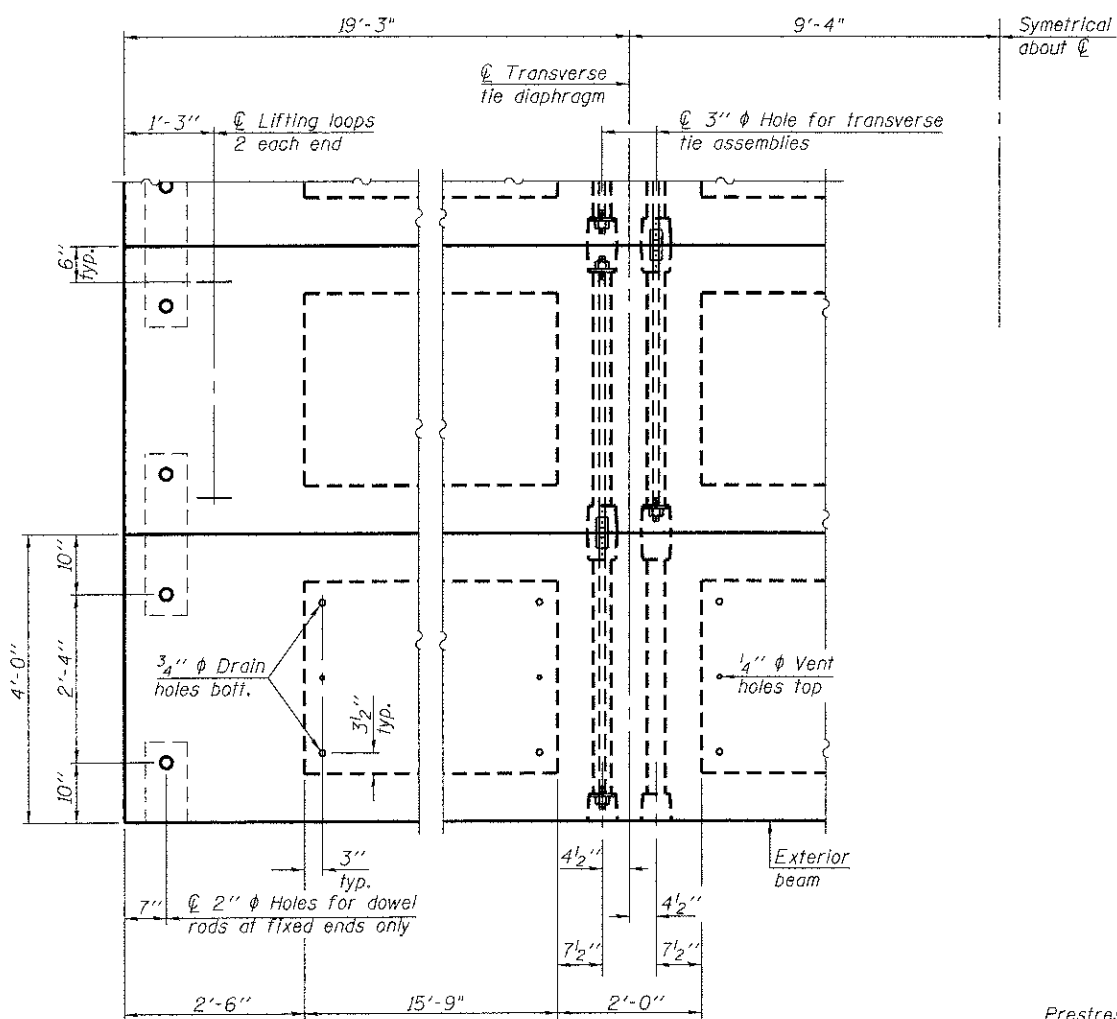

**PLAN VIEW**

Note: Connect beams in pairs with the transverse tie configuration shown.

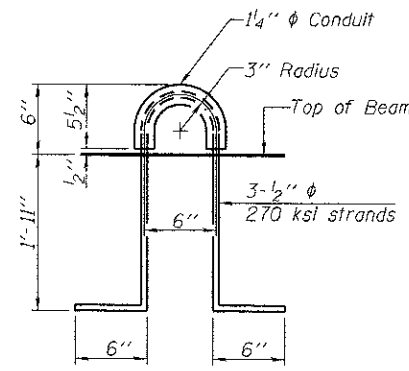

**LIFTING LOOP DETAIL**

**NOTES**

Prestressing steel shall be uncoated high strength, low relaxation 7-wire strand, Grade 270. The nominal diameter shall be 1/2" and the nominal cross-sectional area shall be 0.153 sq. in. The 1" rods in the transverse tie assembly shall be tightened to a snug fit and the threads set. Pockets on exterior faces of bridge shall be filled with grout after transverse tie assembly is in place. Reinforcement bars shall conform to ASTM A 706, Grade 60. (See Special Provisions). Two 1/8" fabric adjusting shims of the dimensions of the exterior bearing pad shall be provided for each bearing pad location. A minimum 2 1/2" diameter lifting pin shall be used to engage the lifting loops during handling. Corrosion Inhibitor, per Article 1020.05(b)(12) and 1021.06 of the Standard Specifications, shall be used in the concrete for precast prestressed concrete deck beams. Compressive strength of prestressed concrete, f'c, shall be 6000 psi. Compressive strength of prestressed concrete at release, f'ci, shall be 5000 psi.

**BILL OF MATERIAL**

|   |         |     |
|---|---------|-----|
| Precast Prestressed Conc. Deck Bms. (27" depth) | Sq. Ft. | 458 |
|---|---------|-----|

PD-2748-0D 7-1-10

|   |                          |                |           |
|---|--------------------------|----------------|-----------|
| FILE NAME = 0496751-009-Deck Beam Details48.dgn   | USER NAME = jehrhert     | DESIGNED - JCE | REVISED - |
| McDonough Associates Inc. Engineers & Architects 140 North Station Ave. Chicago, Illinois 60601 | PLOT SCALE = 1:8.0033333 | CHECKED - GEK  | REVISED - |
| PLOT DATE = 05/14/12  |                          | DRAWN - JCE    | REVISED - |
|   |                          | CHECKED - GEK  | REVISED - |

**STATE OF ILLINOIS**  
**DEPARTMENT OF TRANSPORTATION**

**27" x 48" PPC DECK BEAM DETAILS**  
**STRUCTURE NO. 049-6751**

|                    |                |        |                           |           |
|--------------------|----------------|--------|---------------------------|-----------|
| F.A. RTE.          | SECTION        | COUNTY | TOTAL SHEETS              | SHEET NO. |
|                    | 09-00010-00-BR | LAKE   | 41                        | 22        |
| CONTRACT NO. 63716 |                |        | ILLINOIS FED. AID PROJECT |           |

SHEET NO. 9 OF 16 SHEETS