

SECTION A-A
(showing North sidewalk & parapet)
(South sidewalk similar)

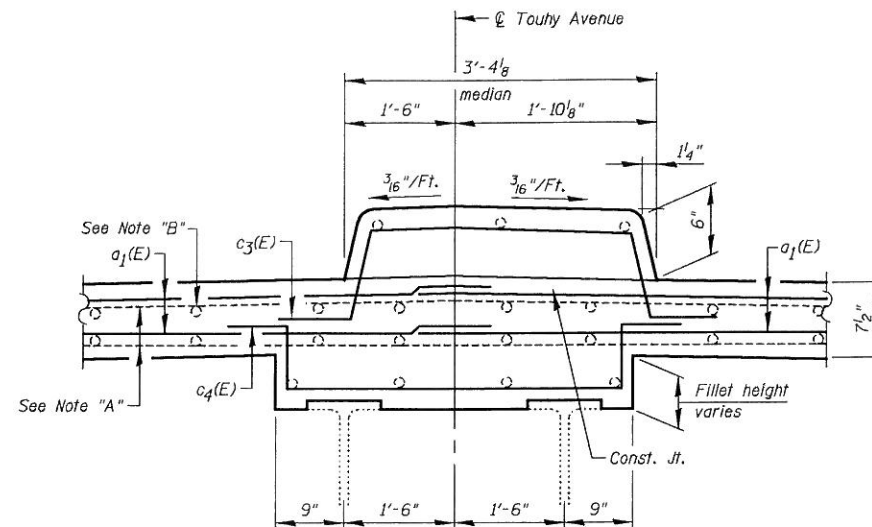

SECTION B-B
(thru median)

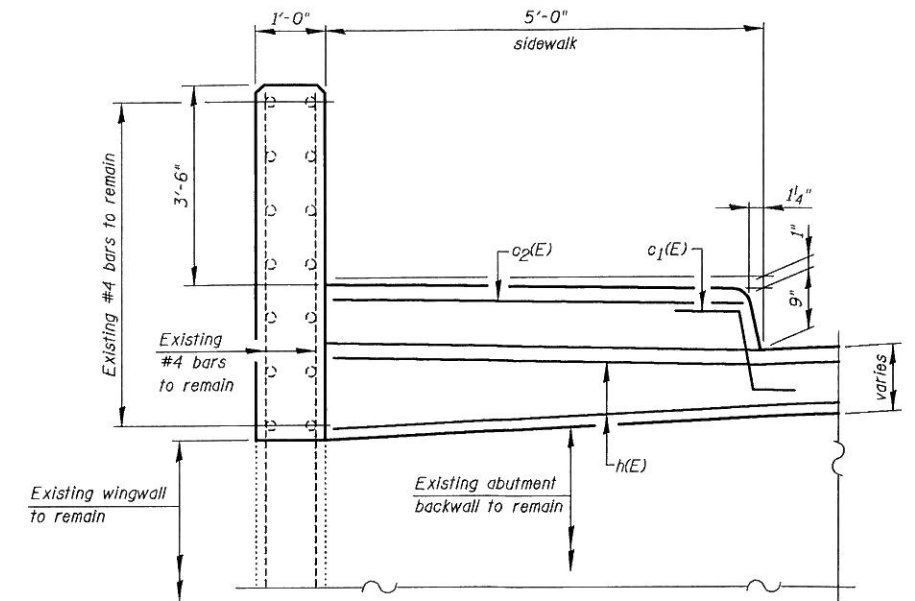

SECTION C-C
North Sidewalk-shown
South Sidewalk-similar

NOTE "A":

Existing transverse reinforcement bars that extend out of the removal area shall remain. These reinf. bars are perpendicular to \perp Touhy Avenue, not parallel to the skew.

NOTE "B":

Existing longitudinal reinforcement bars to remain.

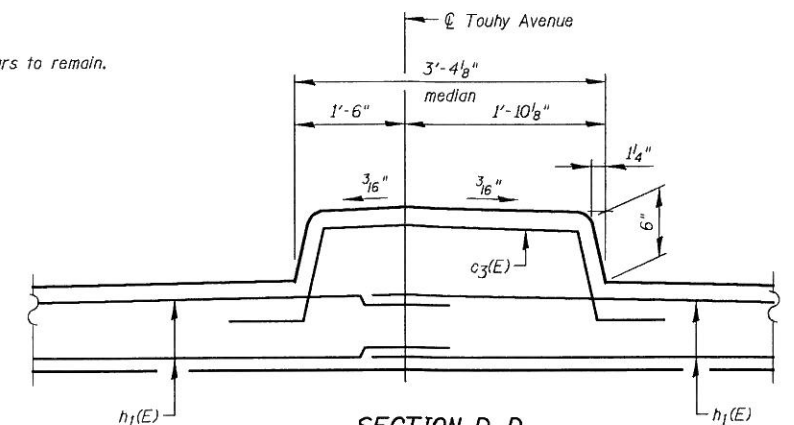

SECTION D-D

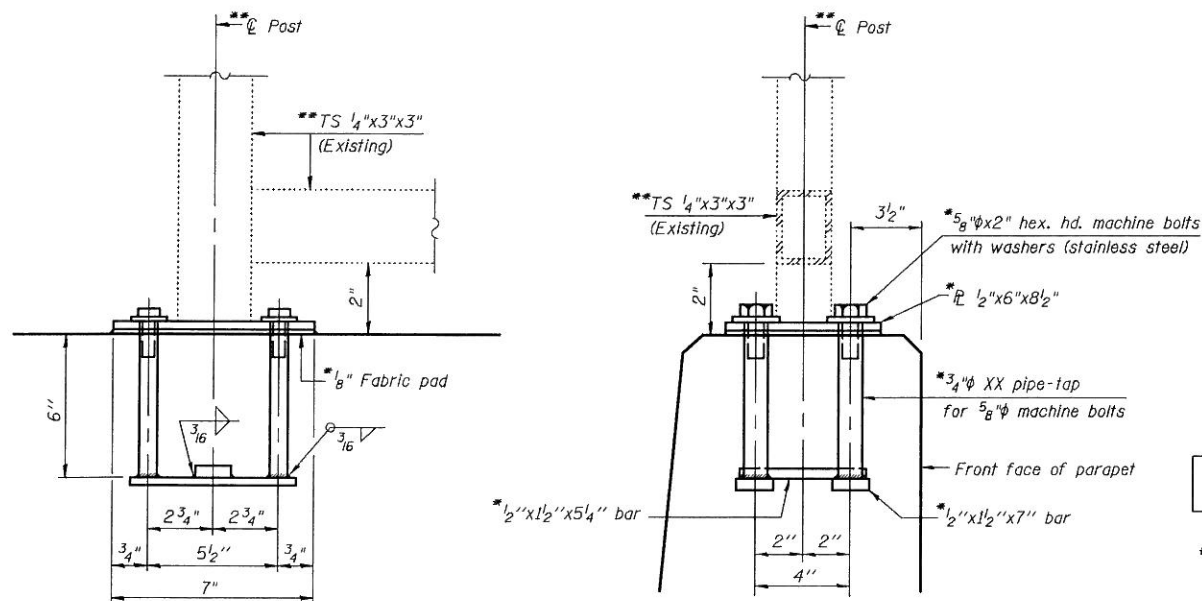

ELEVATION

SECTION

RAIL POST REMOVAL & REPLACEMENT DETAILS ON PARAPETS

* Cost included with Concrete Superstructure

** Remove and store rails in the concrete removal area prior to concrete removal. Remove and store rail post in the concrete removal area. Reattach rail post as shown in Detail "A" and View "D-D", the Contractor must verify locations & sizes of existing holes prior to ordering 3/4" XX pipes, bars, cap screws & standard flat washers. Reinstall rails after concrete superstructure is completed. Cost included with Concrete Superstructure. In lieu of the cast-in-place anchor device shown, the Contractor has the option of drilling and setting stainless steel anchor rods of the same diameter and grade as the specified cap screws according to Article 509.06 of the Standard Specifications. Embedment shall be according to the manufacturer's specifications. Cost included with Concrete Superstructure.

FILE NAME = I:\102915_Touhy-Ave-Structure-1\CADD Sheets\016072-07-1-1-recon-west-abut-II.dgn

USER NAME = 1001	DESIGNED - J.C.N./B.N.S.	REVISED -
PLOT SCALE = 49.999968 / 1 IN.	CHECKED - B.N.S./J.C.N.	REVISED -
PLOT DATE = 5/14/2012	DRAWN - F.M.	REVISED -
	DATE - JANUARY 6, 2012	REVISED -

F.A.I. RTE.	SECTION	COUNTY	TOTAL SHEETS	SHEET NO.
94	0304, 1 HB-1-2	COOK	44	18
CONTRACT NO. 60P72				
ILLINOIS FED. AID PROJECT				