

BAR LIST - EACH FOUNDATION

Bar	Number	Size	Length	Shape
v4(E)	24	#9	F less 5"	—
#4 bar spiral (E) - see Side Elevation				

NOTES:

The foundation dimensions shown are based on the presence of mostly cohesive soils with an average Unconfined Compressive Strength (Qu) of at least 1.25 tsf, which must be determined by previous soil investigations at the jobsite. When other conditions are indicated, the boring data will be included in the plans and the foundation dimensions shown will be the result of site specific designs.

If the conditions encountered are different than those indicated, the Contractor shall notify the Engineer to determine if the foundation dimensions need to be modified. If dimensions "B" or "F" are revised by more than 12" by the Contractor, "as-built" plans shall be prepared and submitted to the District Bureau of Operations for future reference.

No sonotubes or decomposable forms shall be used below the lower conduit entrance. Permanent metal forms or other shielding may not be left in place below that elevation without the Engineer's written permission.

Concrete shall be placed monolithically, without construction joints.

Backfill shall be placed per Article 502 of Standard Specification and prior to erection of support column.

A normal surface finish followed by a Bridge Seat Sealer application will be required on concrete surfaces above the lowest elevation 6" below finished ground line. Cost included in Drilled Shaft Concrete Foundation.

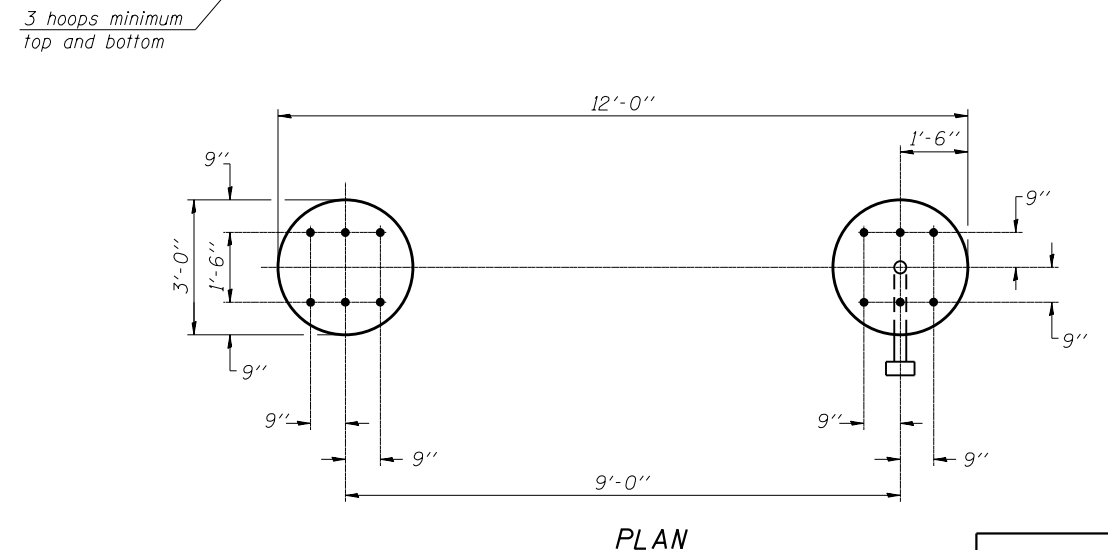
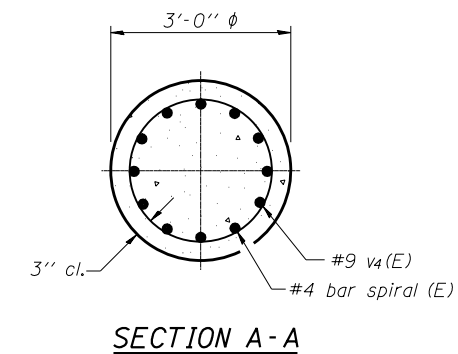
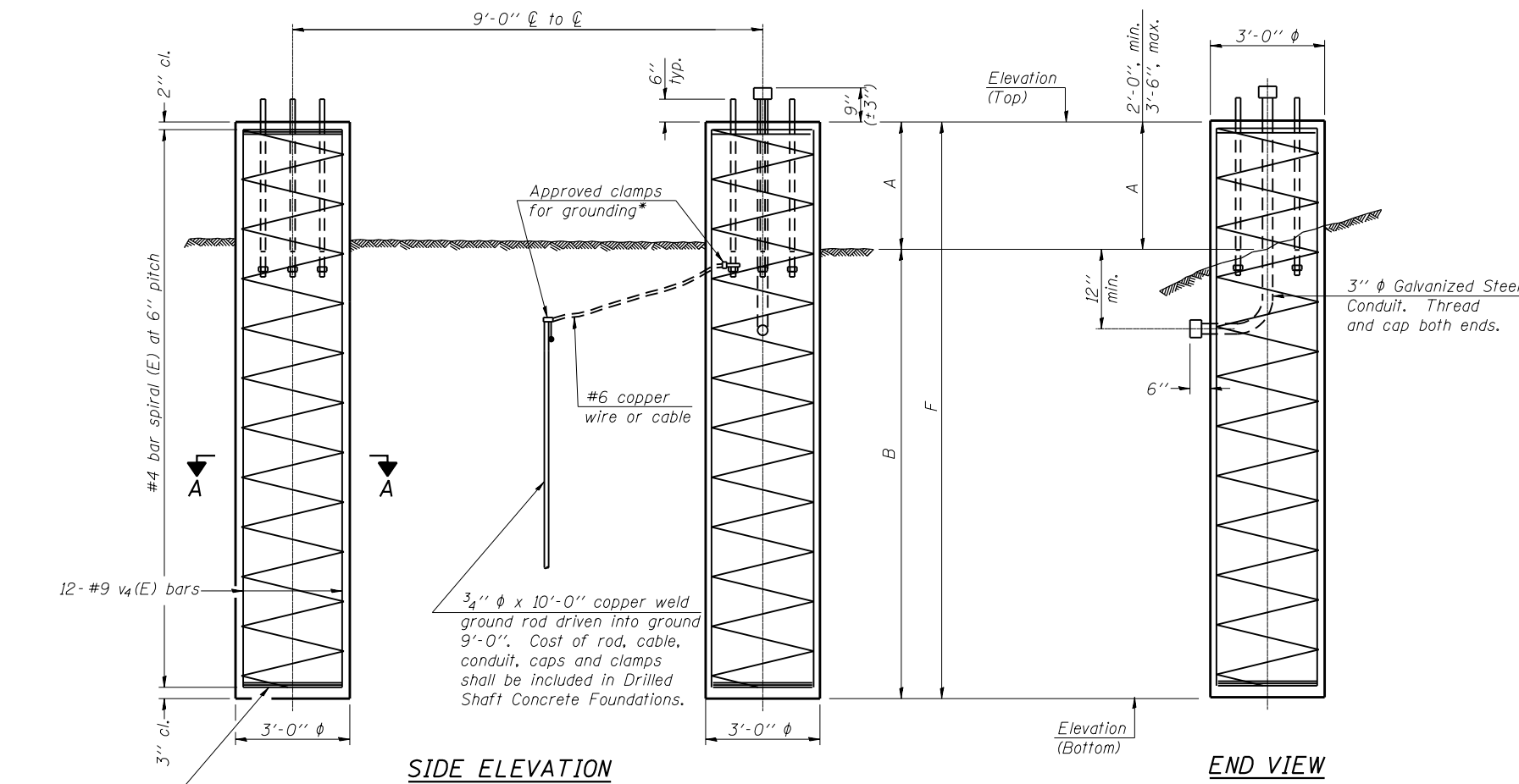

For anchor rod size and placement, see Support Frame Detail Sheet.

* Anchor rod shall be ground or filed to bright metal at clamp and cable connection location.

DETAILS FOR 12" Ø SUPPORT FRAME TYPE III-A TRUSS

Structure Number	Station	Left Foundation					Right Foundation					Class DS Concrete (Cu. Yds.)
		Elevation Top	Elevation Bottom	A	B	F	Elevation Top	Elevation Bottom	A	B	F	
ISO491094R000.9	14076+06	727.52	705.02	3'-6"	19'-0"	22'-6"	727.22	704.72	3'-6"	19'-0"	22'-6"	24
ISO491094R000.7	14085+14	730.52	708.02	3'-6"	19'-0"	22'-6"	728.96	706.46	3'-6"	19'-0"	22'-6"	24

OS4-F4 1-20-11

BOWMAN, BARRETT & ASSOCIATES INC.
CONSULTING ENGINEERS
Chicago, Illinois
312.228.0100
www.bbainc.com

FILE NAME = *FILES*	USER NAME = default	DESIGNED - TF	REVISD
		CHECKED - RGR	REVISED
		DRAWN - TF	REVISED
		CHECKED - RGR	REVISED

STATE OF ILLINOIS
DEPARTMENT OF TRANSPORTATION

OVERHEAD SIGN STRUCTURES
DRILLED SHAFT DETAILS

SHEET NO. 11 OF 12 SHEETS

F.A. RTE.	SECTION	COUNTY	TOTAL SHEETS	SHEET NO.
94	49-1-R-1	LAKE	677	301
CONTRACT NO. 60L77			ILLINOIS FED. AID PROJECT	

Sheet: 0160L77-sht-signstructures-details.dgn

Geo Services, Inc. SOIL BORING LOG PAGE 1 of 1 DATE 12/29/2011-1/4/2012 LOGGED BY RT GSI JOB No. 10193

ROUTE FAI 94 DESCRIPTION I-94 Interchange & Bridge Reconstruction, IDOT Job# D-91-019-11
 SECTION 4-1-R-1 LOCATION Newport Township, Sections 4 & 9, T 46 N, R 11 E, 3rd PM
 COUNTY Lake DRILLING METHOD Hollow Stem Auger/Rotary HAMMER TYPE CME Automatic

STRUCT. NO. ---
 Station ---
 BORING NO. N94-20
 Station 4081+06.5
 Offset 57.5' Right
 Ground Surface Elev. 732.1

DEPTH (ft)	BLOW COUNT (blows/ft)	UCS (tsf)	MOISTURE (%)	DESCRIPTION	DEPTH (ft)	BLOW COUNT (blows/ft)	UCS (tsf)	MOISTURE (%)
0				8.0" ASPHALT, 6.0" Clayey SAND, GRAVEL & STONE	0			
5					1			
7					2			
7	NP	8		GRAVEL-brown & gray-very loose (A-1-a)	1	NP	3	
4					2			
6					1			
5	7	4.5+P	15	CLAY LOAM-brown & gray-very stiff to hard (A-6) Fill	1			NR
4					2			
5					2			
7	2.9B	15		SAND & GRAVEL-brown & gray-very loose (A-1)	2	NP	14	
3					4			
4					6			
10	6	3.0P	16	CLAY-gray-stiff (A-6)	8	1.0P	14	
3								
4				End Of Boring @ -30.0' Hollow Stem Augers to -20.0' Rotary Drilling To Completion 20.0' Of 4.0" Casing Used CME Automatic Hammer				
4	2.3B	18						
2								
4								
15	5	2.4B	18					
3								
3								
4	2.4B	17						
3								
3								
20	3	NP	15	SAND & GRAVEL-brown-very loose (A-1)				

The Unconfined Compressive Strength (UCS) Failure Mode is indicated by (B-Bulge, S-Shear, P-Penetrometer) ST-Shelby Tube Sample VS-Vane Shear Test
 The SPT (N value) is the sum of the last two blow values in each sampling zone (AASHTO T206) The Unit Dry Weight (pcf) is noted in Italics above moist (%)
 NR-No Recovery

Geo Services, Inc. SOIL BORING LOG PAGE 1 of 1 DATE 1/18/2012 LOGGED BY RT GSI JOB No. 10193

ROUTE FAI 94 DESCRIPTION I-94 Interchange & Bridge Reconstruction, IDOT Job# D-91-019-11
 SECTION 4-1-R-1 LOCATION Newport Township, Sections 4 & 9, T 46 N, R 11 E, 3rd PM
 COUNTY Lake DRILLING METHOD Hollow Stem Auger/Rotary HAMMER TYPE CME Automatic

STRUCT. NO. ---
 Station ---
 BORING NO. S94-06
 Station 14084+79.4
 Offset 8.7' Right
 Ground Surface Elev. 730.6

DEPTH (ft)	BLOW COUNT (blows/ft)	UCS (tsf)	MOISTURE (%)	DESCRIPTION	DEPTH (ft)	BLOW COUNT (blows/ft)	UCS (tsf)	MOISTURE (%)
0				10.0" ASPHALT	0			
6					12			
7				SAND & GRAVEL-brown-medium dense (Fill)	9			
7	NP	7			10			7
5					10			
6					9			
5	8	3.1B	16	SILTY CLAY LOAM-gray-medium dense (A-4)	8			16
3					4			
3	1.0SP			CLAY LOAM-dark brown & gray-stiff to very stiff (A-6) Fill	6			117
5	11.3B	22			7	2.1B	15	
4				CLAY-gray-very stiff (A-6)	4			
5					4			119
10	6	3.6B	22		12	2.6B	17	
6								
8				End Of Boring @ -30.0' Hollow Stem Augers CME Automatic Hammer				
7	3.25B	14						
4								
6				CLAY-brown & gray-stiff to hard (A-6)				
15	12	5.2B	19					
3								
3								
6	1.9B	14						
14								
6								
20	7		12	SILTY CLAY LOAM-gray-medium dense (A-4)				

The Unconfined Compressive Strength (UCS) Failure Mode is indicated by (B-Bulge, S-Shear, P-Penetrometer) ST-Shelby Tube Sample VS-Vane Shear Test
 The SPT (N value) is the sum of the last two blow values in each sampling zone (AASHTO T206) The Unit Dry Weight (pcf) is noted in Italics above moist (%)
 NR-No Recovery

Geo Services, Inc. SOIL BORING LOG PAGE 1 of 1 DATE 1/9/2012 LOGGED BY RT GSI JOB No. 10193

ROUTE FAI 94 DESCRIPTION I-94 Interchange & Bridge Reconstruction, IDOT Job# D-91-019-11
 SECTION 4-1-R-1 LOCATION Newport Township, Sections 4 & 9, T 46 N, R 11 E, 3rd PM
 COUNTY Lake DRILLING METHOD Hollow Stem Auger HAMMER TYPE CME Automatic

STRUCT. NO. ---
 Station ---
 BORING NO. S94-09
 Station 14076+26.2
 Offset 45.5' Left
 Ground Surface Elev. 728.3

DEPTH (ft)	BLOW COUNT (blows/ft)	UCS (tsf)	MOISTURE (%)	DESCRIPTION	DEPTH (ft)	BLOW COUNT (blows/ft)	UCS (tsf)	MOISTURE (%)
0				10.0" ASPHALT	0			
4					3			116
10				SAND & GRAVEL-brown-medium dense (Fill)	4			
6	NP	6			5			2.0B 16
4					10B			
4				CLAY LOAM-brown & gray-very stiff (A-6) Fill	4			117
5	6	2.1B	20		3			
4					4			108
8	3.9B	24		CLAY-brown-very stiff (A-6)	6			
9					12			
9					7			120
10	NP	11		SILTY CLAY LOAM-brown & gray-medium dense (A-4)	10			14
3								
5				End Of Boring @ -30.0' Hollow Stem Augers CME Automatic Hammer				
6	3.6B	13						
4								
4								
15	7	4.75B	17	CLAY-gray-very stiff to hard (A-6)				
3								
4								
6	2.3B	16						
3								
3								
20	4	2.0B	16					

The Unconfined Compressive Strength (UCS) Failure Mode is indicated by (B-Bulge, S-Shear, P-Penetrometer) ST-Shelby Tube Sample VS-Vane Shear Test
 The SPT (N value) is the sum of the last two blow values in each sampling zone (AASHTO T206) The Unit Dry Weight (pcf) is noted in Italics above moist (%)
 NR-No Recovery









BOWMAN, BARRETT & ASSOCIATES INC.
 CONSULTING ENGINEERS
 Chicago, Illinois
 312.228.0100
 www.bbandainc.com



FILE NAME = \$FILES\$	USER NAME = default	DESIGNED - TF	REVISED -	STATE OF ILLINOIS DEPARTMENT OF TRANSPORTATION	SOIL BORING LOGS SIGN STRUCTURES	F.A. RTE. 94	SECTION 49-1-R-1	COUNTY LAKE	TOTAL SHEETS 677	SHEET NO. 303		
PLOT SCALE = H11"=10' V11"=5'	CHECKED - RGR	REVISED -	SCALE:			SHEET NO. 1 OF 2 SHEETS	STA. N/A TO STA. N/A	CONTRACT NO. 60L77				
PLOT DATE = 6/20/2012	DATE = 6/19/2012	REVISED -	ILLINOIS FED. AID PROJECT									

S:\1101\95\CADD\60L77 IL 175\60L77 Sheets\1160L77-shr-signstructures-borings.dgn

LEGEND

-  SODDING, SALT TOLERANT (25200110)
-  SEEDING, CLASS 2A (25000210)
MULCH, METHOD 1 (25100105)
EROSION CONTROL BLANKET (25100630)
TOPSOIL EXCAVATION AND PLACE (1 FT) (21101505)
-  SEEDING, CLASS 4 (25000310)
MULCH, METHOD 1 (25100105)
EROSION CONTROL BLANKET (25100630)
TOPSOIL EXCAVATION AND PLACE (1 FT) (21101505)
-  SEEDING, CLASS 4A (25000312)
MULCH, METHOD 1 (25100105)
EROSION CONTROL BLANKET (25100630)
TOPSOIL EXCAVATION AND PLACE (1 FT) (21101505)
-  SEEDING, CLASS 2E (JS250220)
MULCH, METHOD 1 (25100105)
EROSION CONTROL BLANKET (25100630)
TOPSOIL EXCAVATION AND PLACE (1 FT) (21101505)
-  SEEDING, CLASS 4F (JS250318)
MULCH, METHOD 1 (25100105)
EROSION CONTROL BLANKET (25100630)
TOPSOIL EXCAVATION AND PLACE (1 FT) (21101505)
-  SEEDING, CLASS 2A (25000210)
TOPSOIL FURNISH AND PLACE, 24" (21101685)
-  PROPOSED TREE

GENERAL NOTES

SEEDING AND TOPSOIL PLACEMENT WILL BE PLACE ATOP DISTURBED EARTH AS SHOWN IN THE CROSS SECTIONS, AND AS DESIGNATED BY THE ENGINEER.

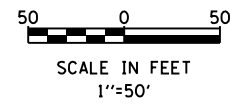
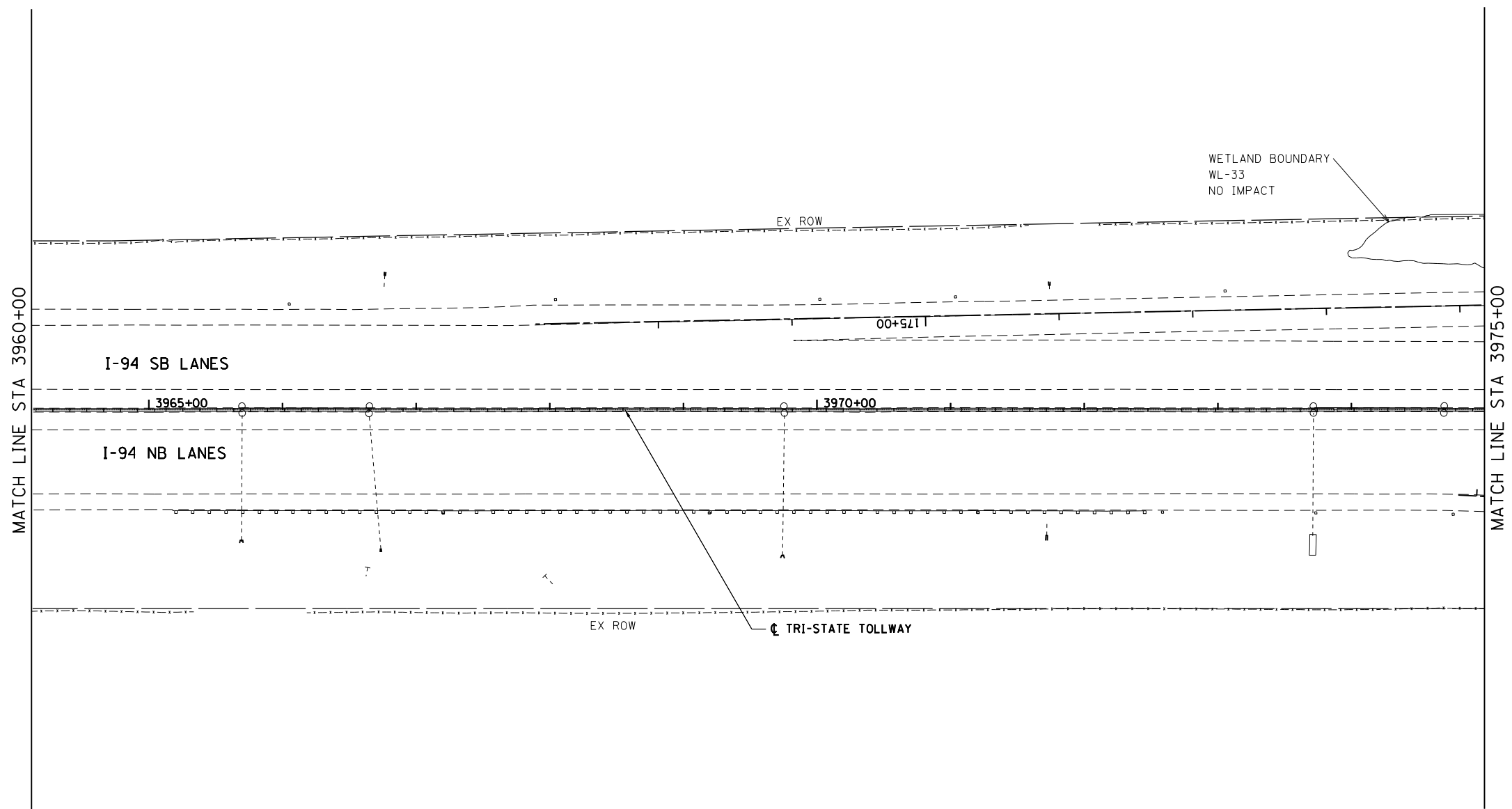

BOWMAN, BARRETT & ASSOCIATES INC.
CONSULTING ENGINEERS
Chicago, Illinois
312.228.0100
www.bbandainc.com



FILE NAME = \$FILES\$	USER NAME = default	DESIGNED - PTG	REVISED -
		DRAWN - PTG	REVISED -
	PLOT SCALE = H=1"=10' V=1"=5'	CHECKED - RGR	REVISED -
	PLOT DATE = 6/20/2012	DATE - 6/19/2012	REVISED -

**STATE OF ILLINOIS
DEPARTMENT OF TRANSPORTATION**























LANDSCAPING PLAN NB I-94 AND SB I-94

SCALE: 1"=50' SHEET NO. 1 OF 15 SHEETS STA. 3960+00 TO STA. 3975+00

F.A. RTE.	SECTION	COUNTY	TOTAL SHEETS	SHEET NO.
94	49-1-R-1	LAKE	677	305
CONTRACT NO. 60L 77			ILLINOIS FED. AID PROJECT	

S:\1101\95-CADD\60L77_IL_173\60L77_Sheets\1160L77-shr-landscap01.dgn

LEGEND

- | | | | |
|---|--|--|--|
|  | SODDING, SALT TOLERANT (25200110) |  | SEEDING, CLASS 2E (JS250220) |
|  | SEEDING, CLASS 2A (25000210) |  | MULCH, METHOD 1 (25100105) |
|  | EROSION CONTROL BLANKET (25100630) |  | EROSION CONTROL BLANKET (25100630) |
|  | TOPSOIL EXCAVATION AND PLACE (1 FT) (21101505) |  | TOPSOIL EXCAVATION AND PLACE (1 FT) (21101505) |
|  | SEEDING, CLASS 4 (25000310) |  | SEEDING, CLASS 4F (JS250318) |
|  | MULCH, METHOD 1 (25100105) |  | MULCH, METHOD 1 (25100105) |
|  | EROSION CONTROL BLANKET (25100630) |  | EROSION CONTROL BLANKET (25100630) |
|  | TOPSOIL EXCAVATION AND PLACE (1 FT) (21101505) |  | TOPSOIL EXCAVATION AND PLACE (1 FT) (21101505) |
|  | SEEDING, CLASS 4A (25000312) |  | SEEDING, CLASS 2A (25000210) |
|  | MULCH, METHOD 1 (25100105) |  | TOPSOIL FURNISH AND PLACE, 24" (21101685) |
|  | EROSION CONTROL BLANKET (25100630) |  | PROPOSED TREE |
|  | TOPSOIL EXCAVATION AND PLACE (1 FT) (21101505) | | |

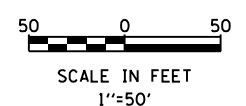
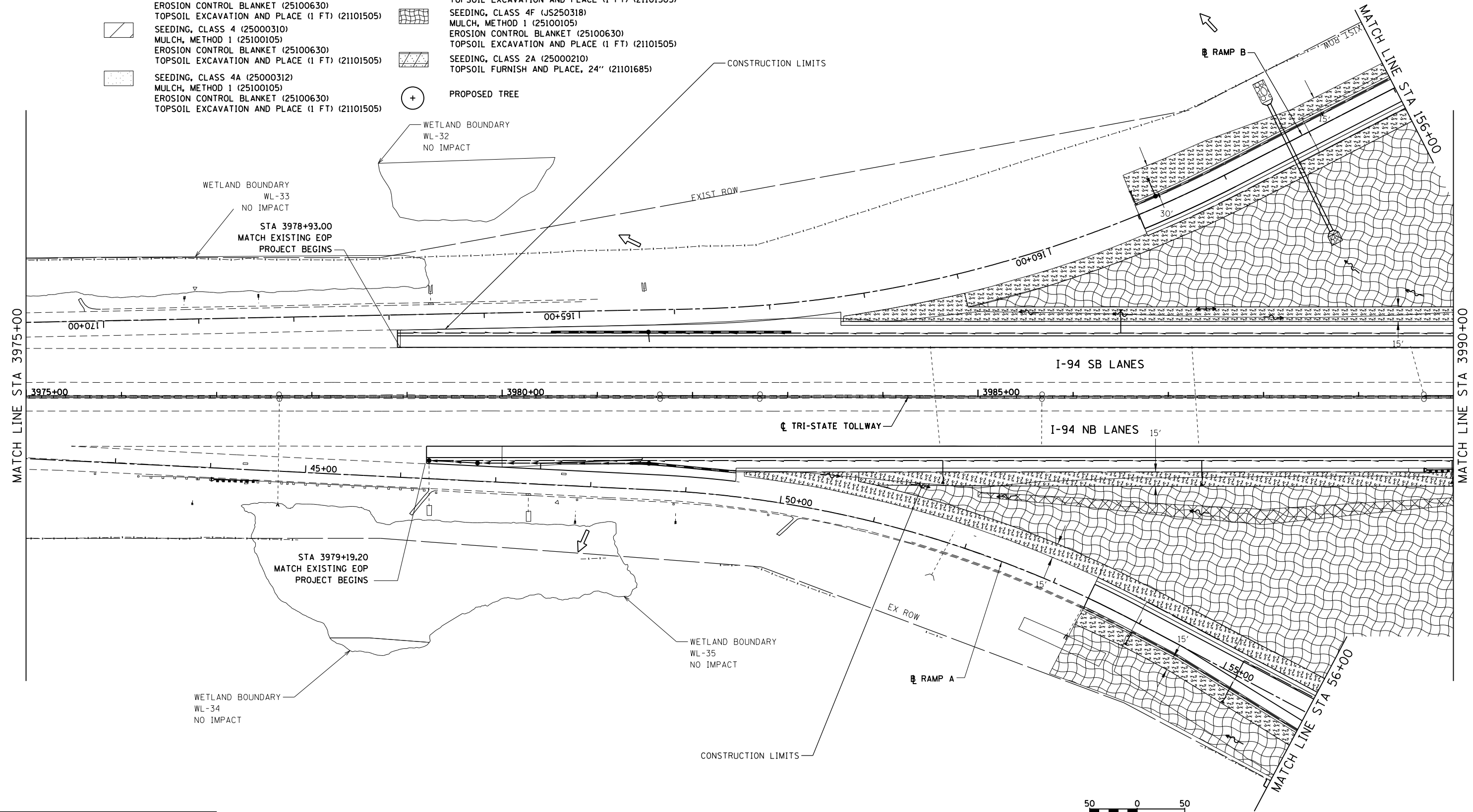

BOWMAN, BARRETT & ASSOCIATES INC.
 CONSULTING ENGINEERS
 Chicago, Illinois
 312.228.0100
 www.bbandainc.com

FILE NAME = \$FILES\$	USER NAME = default	DESIGNED - PTG	REVISED -
		DRAWN - PTG	REVISED -
	PLOT SCALE = Hgt=10" Wdt=5"	CHECKED - RGR	REVISED -
	PLOT DATE = 6/20/2012	DATE - 6/19/2012	REVISED -

**STATE OF ILLINOIS
 DEPARTMENT OF TRANSPORTATION**

LANDSCAPING PLAN NB I-94 AND SB I-94
 SCALE: 1"=50' SHEET NO. 2 OF 15 SHEETS STA. 3975+00 TO STA. 3990+00

F.A. RTE.	SECTION	COUNTY	TOTAL SHEETS	SHEET NO.
94	49-1-R-1	LAKE	677	306
CONTRACT NO. 60L77				
ILLINOIS FED. AID PROJECT				

S:\1101\95\CADD\60L77_IL_175\60L77_Sheets\0160L77_sht-landscp02.dgn

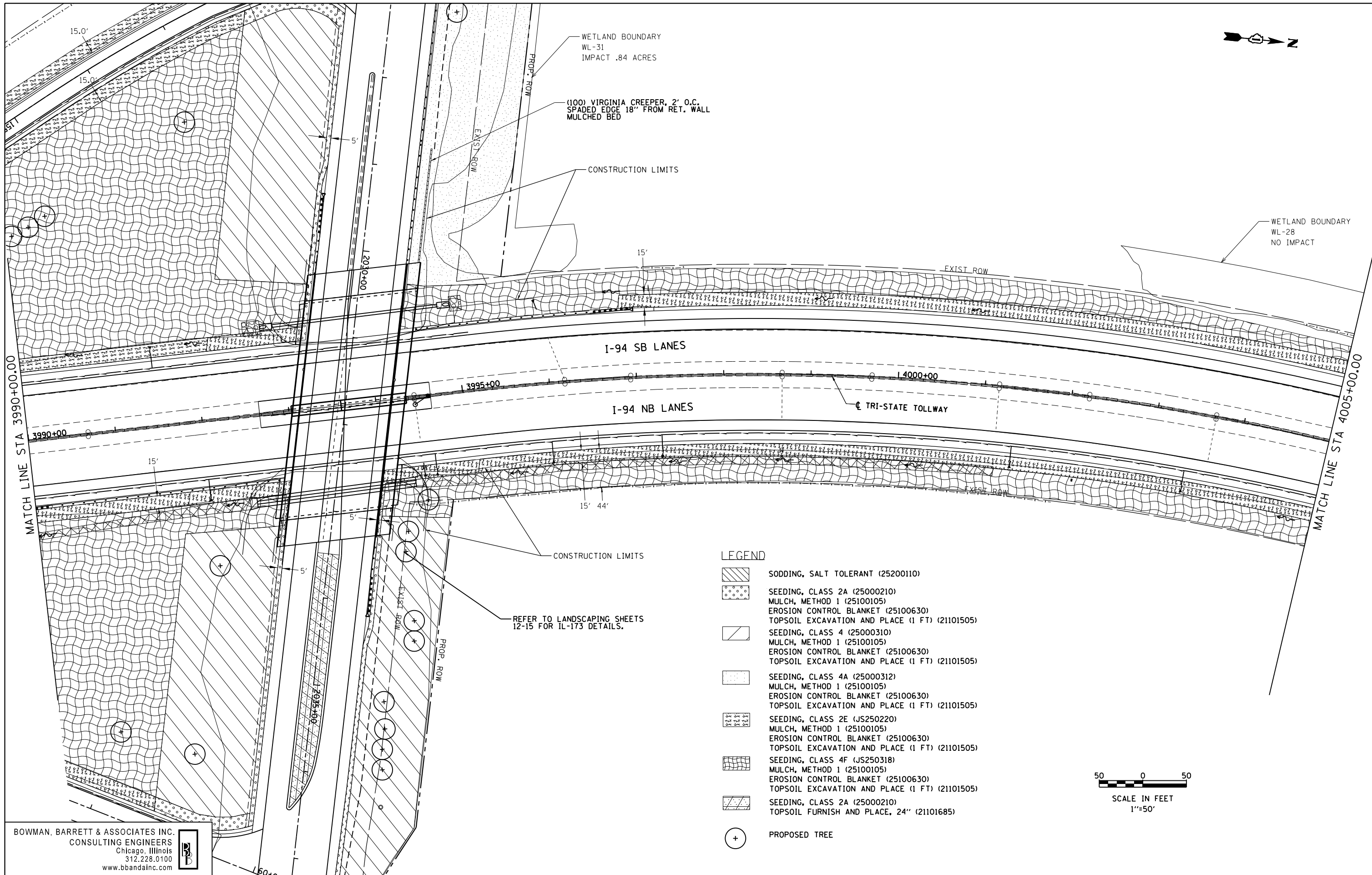

BOWMAN, BARRETT & ASSOCIATES INC.
 CONSULTING ENGINEERS
 Chicago, Illinois
 312.228.0100
 www.bbandainc.com

- LEGEND**
- SODDING, SALT TOLERANT (25200110)
 - SEEDING, CLASS 2A (25000210)
MULCH, METHOD 1 (25100105)
EROSION CONTROL BLANKET (25100630)
TOPSOIL EXCAVATION AND PLACE (1 FT) (21101505)
 - SEEDING, CLASS 4 (25000310)
MULCH, METHOD 1 (25100105)
EROSION CONTROL BLANKET (25100630)
TOPSOIL EXCAVATION AND PLACE (1 FT) (21101505)
 - SEEDING, CLASS 4A (25000312)
MULCH, METHOD 1 (25100105)
EROSION CONTROL BLANKET (25100630)
TOPSOIL EXCAVATION AND PLACE (1 FT) (21101505)
 - SEEDING, CLASS 2E (JS250220)
MULCH, METHOD 1 (25100105)
EROSION CONTROL BLANKET (25100630)
TOPSOIL EXCAVATION AND PLACE (1 FT) (21101505)
 - SEEDING, CLASS 4F (JS250318)
MULCH, METHOD 1 (25100105)
EROSION CONTROL BLANKET (25100630)
TOPSOIL EXCAVATION AND PLACE (1 FT) (21101505)
 - SEEDING, CLASS 2A (25000210)
TOPSOIL FURNISH AND PLACE, 24" (21101685)
 - PROPOSED TREE

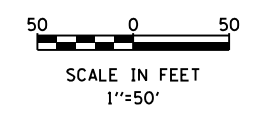

FILE NAME = \$FILES\$
 USER NAME = default
 PLOT SCALE = Ht1=10" Wt1=5"
 PLOT DATE = 6/20/2012

DESIGNED -	PTG	REVISED -	
DRAWN -	PTG	REVISED -	
CHECKED -	RGR	REVISED -	
DATE -	6/19/2012	REVISED -	

**STATE OF ILLINOIS
 DEPARTMENT OF TRANSPORTATION**







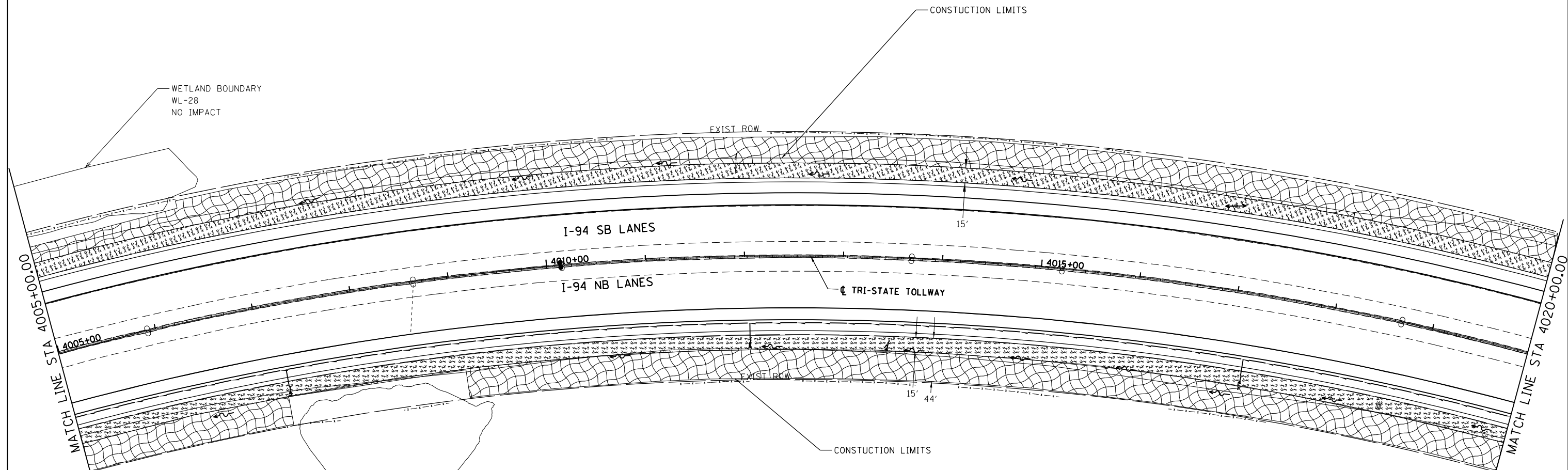

LANDSCAPING PLAN NB I-94 AND SB I-94
 SCALE: 1"=50' SHEET NO. 3 OF 15 SHEETS STA. 3990+00 TO STA. 4005+00

F.A. RTE.	SECTION	COUNTY	TOTAL SHEETS	SHEET NO.
94	49-1-R-1	LAKE	677	307
CONTRACT NO. 60L77				
ILLINOIS FED. AID PROJECT				

S:\1101\95-CADD\60L77_IL_175\60L77_Sheets\0160L77-shr-landscp03.dgn



LEGEND

-  SODDING, SALT TOLERANT (25200110)
-  SEEDING, CLASS 2A (25000210)
MULCH, METHOD 1 (25100105)
EROSION CONTROL BLANKET (25100630)
TOPSOIL EXCAVATION AND PLACE (1 FT) (21101505)
-  SEEDING, CLASS 4 (25000310)
MULCH, METHOD 1 (25100105)
EROSION CONTROL BLANKET (25100630)
TOPSOIL EXCAVATION AND PLACE (1 FT) (21101505)
-  SEEDING, CLASS 4A (25000312)
MULCH, METHOD 1 (25100105)
EROSION CONTROL BLANKET (25100630)
TOPSOIL EXCAVATION AND PLACE (1 FT) (21101505)
-  SEEDING, CLASS 2E (JS250220)
MULCH, METHOD 1 (25100105)
EROSION CONTROL BLANKET (25100630)
TOPSOIL EXCAVATION AND PLACE (1 FT) (21101505)
-  SEEDING, CLASS 4F (JS250318)
MULCH, METHOD 1 (25100105)
EROSION CONTROL BLANKET (25100630)
TOPSOIL EXCAVATION AND PLACE (1 FT) (21101505)
-  SEEDING, CLASS 2A (25000210)
TOPSOIL FURNISH AND PLACE, 24" (21101685)
-  PROPOSED TREE

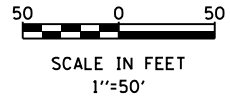

BOWMAN, BARRETT & ASSOCIATES INC.
CONSULTING ENGINEERS
Chicago, Illinois
312.228.0100
www.bbandainc.com

FILE NAME = \$FILES\$	USER NAME = default	DESIGNED - PTG	REVISED -
		DRAWN - PTG	REVISED -
	PLOT SCALE = H=1"=10' V=1"=5'	CHECKED - RGR	REVISED -
	PLOT DATE = 6/20/2012	DATE - 6/19/2012	REVISED -

**STATE OF ILLINOIS
DEPARTMENT OF TRANSPORTATION**

LANDSCAPING PLAN NB I-94 AND SB I-94

SCALE: 1"=50' SHEET NO. 4 OF 15 SHEETS STA. 4005+00 TO STA. 4020+00

F.A. RTE.	SECTION	COUNTY	TOTAL SHEETS	SHEET NO.
94	49-1-R-1	LAKE	677	308
CONTRACT NO. 60L77				
ILLINOIS FED. AID PROJECT				

S:\1101\95-CADD\60L77_IL_175\60L77_Sheets\0160L77-shs-landscp04.dgn

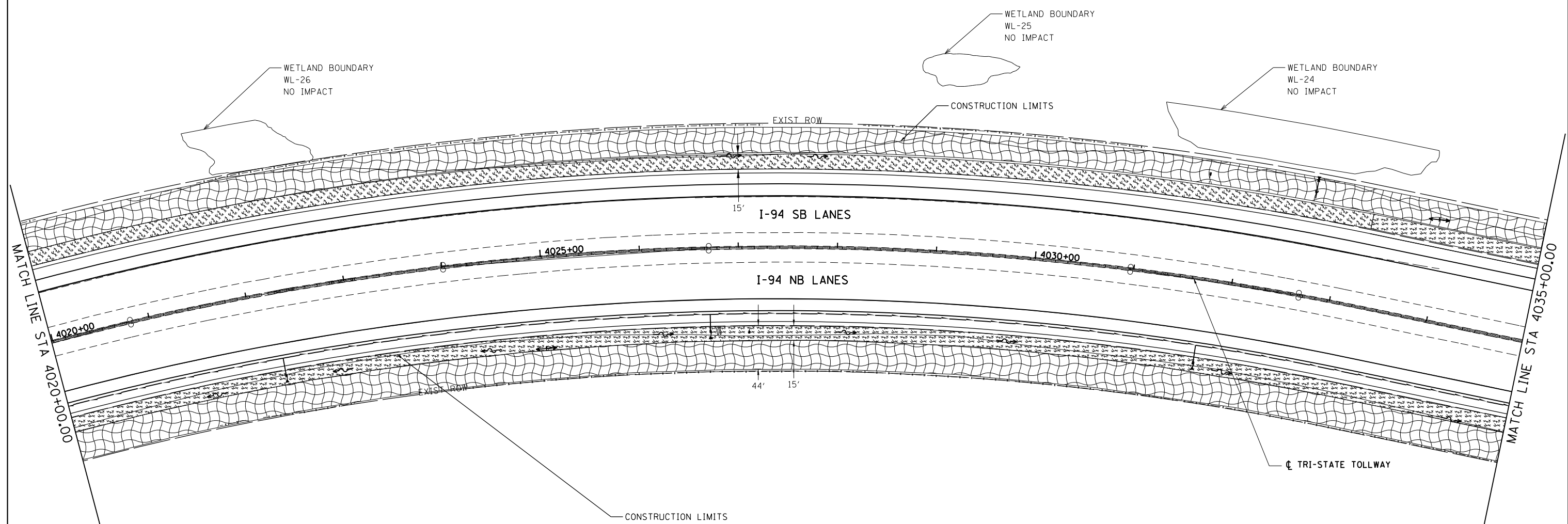
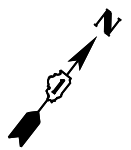

LEGEND

- | | | | |
|--|--|--|--|
| | SODDING, SALT TOLERANT (25200110) | | SEEDING, CLASS 2E (JS250220) |
| | SEEDING, CLASS 2A (25000210) | | MULCH, METHOD 1 (25100105) |
| | MULCH, METHOD 1 (25100105) | | EROSION CONTROL BLANKET (25100630) |
| | EROSION CONTROL BLANKET (25100630) | | TOPSOIL EXCAVATION AND PLACE (1 FT) (21101505) |
| | TOPSOIL EXCAVATION AND PLACE (1 FT) (21101505) | | SEEDING, CLASS 4F (JS250318) |
| | SEEDING, CLASS 4 (25000310) | | MULCH, METHOD 1 (25100105) |
| | MULCH, METHOD 1 (25100105) | | EROSION CONTROL BLANKET (25100630) |
| | EROSION CONTROL BLANKET (25100630) | | TOPSOIL EXCAVATION AND PLACE (1 FT) (21101505) |
| | TOPSOIL EXCAVATION AND PLACE (1 FT) (21101505) | | SEEDING, CLASS 2A (25000210) |
| | SEEDING, CLASS 4A (25000312) | | TOPSOIL FURNISH AND PLACE, 24" (21101685) |
| | MULCH, METHOD 1 (25100105) | | PROPOSED TREE |
| | EROSION CONTROL BLANKET (25100630) | | |
| | TOPSOIL EXCAVATION AND PLACE (1 FT) (21101505) | | |

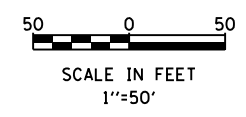

BOWMAN, BARRETT & ASSOCIATES INC.
 CONSULTING ENGINEERS
 Chicago, Illinois
 312.228.0100
 www.bbandainc.com

FILE NAME = \$FILES\$	USER NAME = default	DESIGNED - PTG	REVISED -
		DRAWN - PTG	REVISED -
		CHECKED - RGR	REVISED -
		DATE - 6/19/2012	REVISED -

**STATE OF ILLINOIS
 DEPARTMENT OF TRANSPORTATION**

LANDSCAPING PLAN NB I-94 AND SB I-94

SCALE: 1"=50' SHEET NO. 5 OF 15 SHEETS STA. 4020+00 TO STA. 4035+00

F.A. RTE.	SECTION	COUNTY	TOTAL SHEETS	SHEET NO.
94	49-1-R-1	LAKE	677	309
ILLINOIS FED. AID PROJECT			CONTRACT NO. 60L77	

S:\1101\95\CADD\60L77_IL_173\60L77_Sheets\160L77-shr-landscap95.dgn

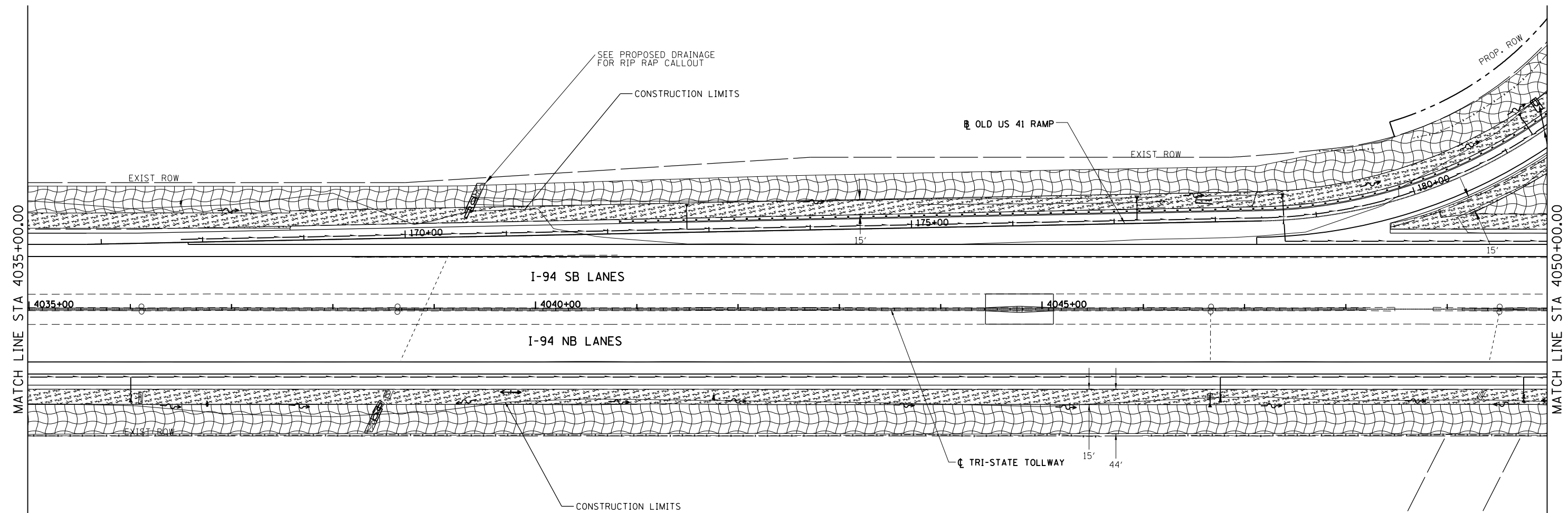

LEGEND

- | | | | |
|--|--|--|--|
| | SODDING, SALT TOLERANT (25200110) | | SEEDING, CLASS 2E (JS250220) |
| | SEEDING, CLASS 2A (25000210) | | MULCH, METHOD 1 (25100105) |
| | MULCH, METHOD 1 (25100105) | | EROSION CONTROL BLANKET (25100630) |
| | EROSION CONTROL BLANKET (25100630) | | TOPSOIL EXCAVATION AND PLACE (1 FT) (21101505) |
| | TOPSOIL EXCAVATION AND PLACE (1 FT) (21101505) | | SEEDING, CLASS 4F (JS250318) |
| | SEEDING, CLASS 4 (25000310) | | MULCH, METHOD 1 (25100105) |
| | MULCH, METHOD 1 (25100105) | | EROSION CONTROL BLANKET (25100630) |
| | EROSION CONTROL BLANKET (25100630) | | TOPSOIL EXCAVATION AND PLACE (1 FT) (21101505) |
| | TOPSOIL EXCAVATION AND PLACE (1 FT) (21101505) | | SEEDING, CLASS 2A (25000210) |
| | SEEDING, CLASS 4A (25000312) | | TOPSOIL FURNISH AND PLACE, 24" (21101685) |
| | MULCH, METHOD 1 (25100105) | | PROPOSED TREE |
| | EROSION CONTROL BLANKET (25100630) | | |
| | TOPSOIL EXCAVATION AND PLACE (1 FT) (21101505) | | |

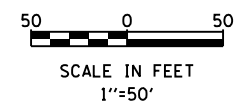

BOWMAN, BARRETT & ASSOCIATES INC.
 CONSULTING ENGINEERS
 Chicago, Illinois
 312.228.0100
 www.bbandainc.com

FILE NAME = \$FILES\$	USER NAME = default	DESIGNED - PTG	REVISED -
		DRAWN - PTG	REVISED -
	PLOT SCALE = H=1"=10' V=1"=5'	CHECKED - RGR	REVISED -
	PLOT DATE = 6/20/2012	DATE - 6/19/2012	REVISED -

**STATE OF ILLINOIS
 DEPARTMENT OF TRANSPORTATION**

LANDSCAPING PLAN NB I-94 AND SB I-94

SCALE: 1"=50' SHEET NO. 6 OF 15 SHEETS STA. 4035+00 TO STA. 4050+00

F.A. RTE.	SECTION	COUNTY	TOTAL SHEETS	SHEET NO.
94	49-1-R-1	LAKE	677	310
CONTRACT NO. 60L77				
ILLINOIS FED. AID PROJECT				

S:\1101\95\CADD\60L77_IL_175\60L77_Sheets\0160L77-shr-landscp06.dgn



LEGEND
SEE LANDSCAPING PAGE 6 FOR LEGEND.

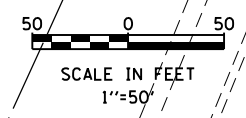
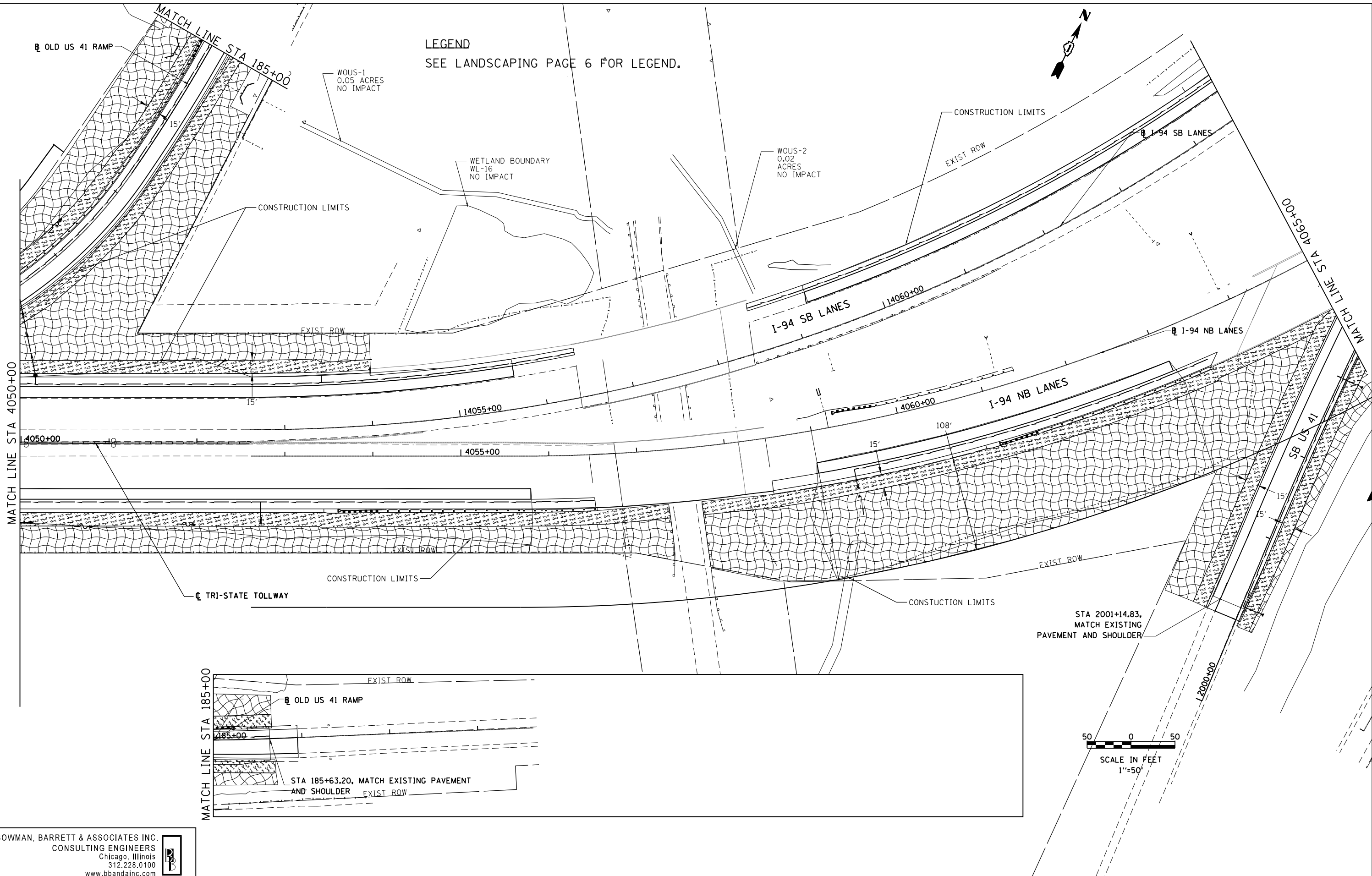

BOWMAN, BARRETT & ASSOCIATES INC.
CONSULTING ENGINEERS
Chicago, Illinois
312.228.0100
www.bbandainc.com

FILE NAME = \$FILES\$	USER NAME = default	DESIGNED - PTG	REVISED -
		DRAWN - PTG	REVISED -
	PLOT SCALE = Hgt=10' Wdt=5'	CHECKED - RGR	REVISED -
	PLOT DATE = 6/20/2012	DATE - 6/19/2012	REVISED -

STATE OF ILLINOIS
DEPARTMENT OF TRANSPORTATION

LANDSCAPING PLAN NB I-94 AND SB I-94

SCALE: SHEET NO. 7 OF 15 SHEETS STA. 4050+00 TO STA. 4065+00

F.A. RTE.	SECTION	COUNTY	TOTAL SHEETS	SHEET NO.
94	49-1-R-1	LAKE	677	311
CONTRACT NO. 60L77				
ILLINOIS FED. AID PROJECT				

S:\1101\95\CADD\60L77_IL_173\60L77_Sheets\0160L77-shs-landscap07.dgn

LEGEND
SEE LANDSCAPING PAGE 6 FOR LEGEND.

WETLAND BOUNDARY
WL-13
WETLAND IMPACT
0.01 ACRE

CONSTRUCTION LIMITS

STA 14069+44.84
JURISDICTIONAL
LIMIT

ISTHA IDOT

EXIST ROW

CONSTRUCTION LIMITS

MATCH LINE STA 4065+00

MATCH LINE STA 4080+00

I-94 SB LANES

I-94 SB LANES

SB US 41

I-94 NB LANES

AREA OF DETENTION BASIN

I-94 NB LANES

I-94 NB LANES

NB US 41

EXIST ROW

ISTHA IDOT

50 0 50
SCALE IN FEET
1"=50'

MATCH LINE STA 102+00

MATCH LINE STA 102+00

BOWMAN, BARRETT & ASSOCIATES INC.
CONSULTING ENGINEERS
Chicago, Illinois
312.228.0100
www.bbandainc.com



FILE NAME = \$FILES\$

USER NAME = default

PLOT SCALE = H=1"=10' V=1"=5'

PLOT DATE = 6/20/2012

DESIGNED - PTG

DRAWN - PTG

CHECKED - RGR

DATE - 6/19/2012

REVISED -

REVISED -

REVISED -

REVISED -

STATE OF ILLINOIS
DEPARTMENT OF TRANSPORTATION

LANDSCAPING PLAN NB I-94 AND SB I-94







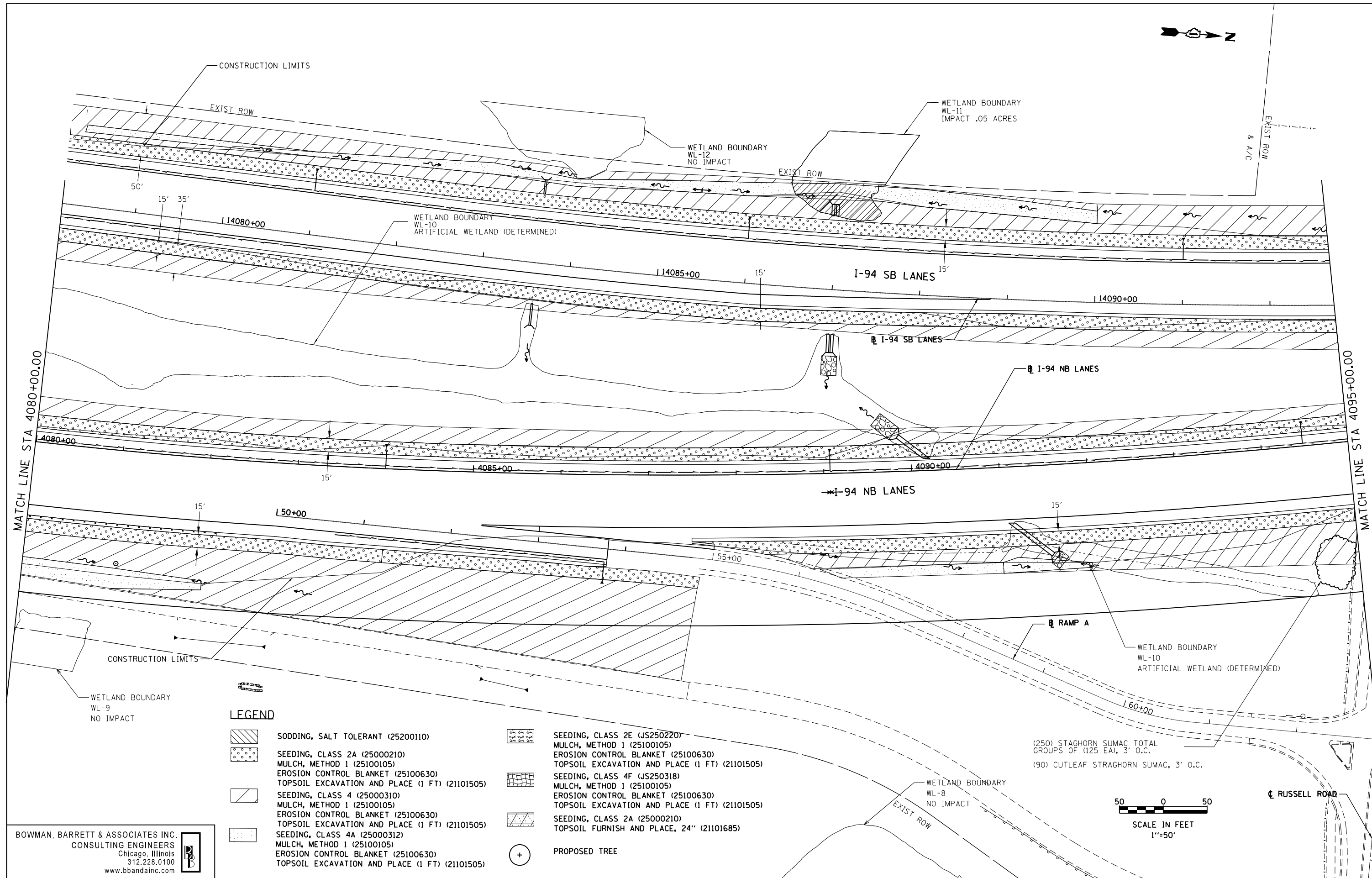

SCALE: SHEET NO. 8 OF 15 SHEETS STA. 4065+00 TO STA. 4078+00

F.A. RTE.	SECTION	COUNTY	TOTAL SHEETS	SHEET NO.
94	49-1-R-1	LAKE	677	312
CONTRACT NO. 60L77				
ILLINOIS FED. AID PROJECT				

S:\1101\985\CADD\60L77_IL_173\60L77_Sheets\1160L77-shr-landscp98.dgn



LEGEND

-  SODDING, SALT TOLERANT (25200110)
-  SEEDING, CLASS 2A (25000210)
MULCH, METHOD 1 (25100105)
EROSION CONTROL BLANKET (25100630)
TOPSOIL EXCAVATION AND PLACE (1 FT) (21101505)
-  SEEDING, CLASS 4 (25000310)
MULCH, METHOD 1 (25100105)
EROSION CONTROL BLANKET (25100630)
TOPSOIL EXCAVATION AND PLACE (1 FT) (21101505)
-  SEEDING, CLASS 4A (25000312)
MULCH, METHOD 1 (25100105)
EROSION CONTROL BLANKET (25100630)
TOPSOIL EXCAVATION AND PLACE (1 FT) (21101505)
-  SEEDING, CLASS 2E (JS250220)
MULCH, METHOD 1 (25100105)
EROSION CONTROL BLANKET (25100630)
TOPSOIL EXCAVATION AND PLACE (1 FT) (21101505)
-  SEEDING, CLASS 4F (JS250318)
MULCH, METHOD 1 (25100105)
EROSION CONTROL BLANKET (25100630)
TOPSOIL EXCAVATION AND PLACE (1 FT) (21101505)
-  SEEDING, CLASS 2A (25000210)
TOPSOIL FURNISH AND PLACE, 24" (21101685)
-  PROPOSED TREE

(250) STAGHORN SUMAC TOTAL GROUPS OF (125 EA), 3' O.C.
(90) CUTLEAF STAGHORN SUMAC, 3' O.C.

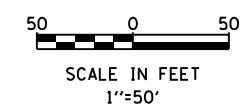

BOWMAN, BARRETT & ASSOCIATES INC.
CONSULTING ENGINEERS
Chicago, Illinois
312.228.0100
www.bbandainc.com

FILE NAME = \$FILES\$	USER NAME = default	DESIGNED - PTG	REVISED -
		DRAWN - PTG	REVISED -
		CHECKED - RGR	REVISED -
		DATE - 6/19/2012	REVISED -

**STATE OF ILLINOIS
DEPARTMENT OF TRANSPORTATION**

LANDSCAPING PLAN NB I-94 AND SB I-94







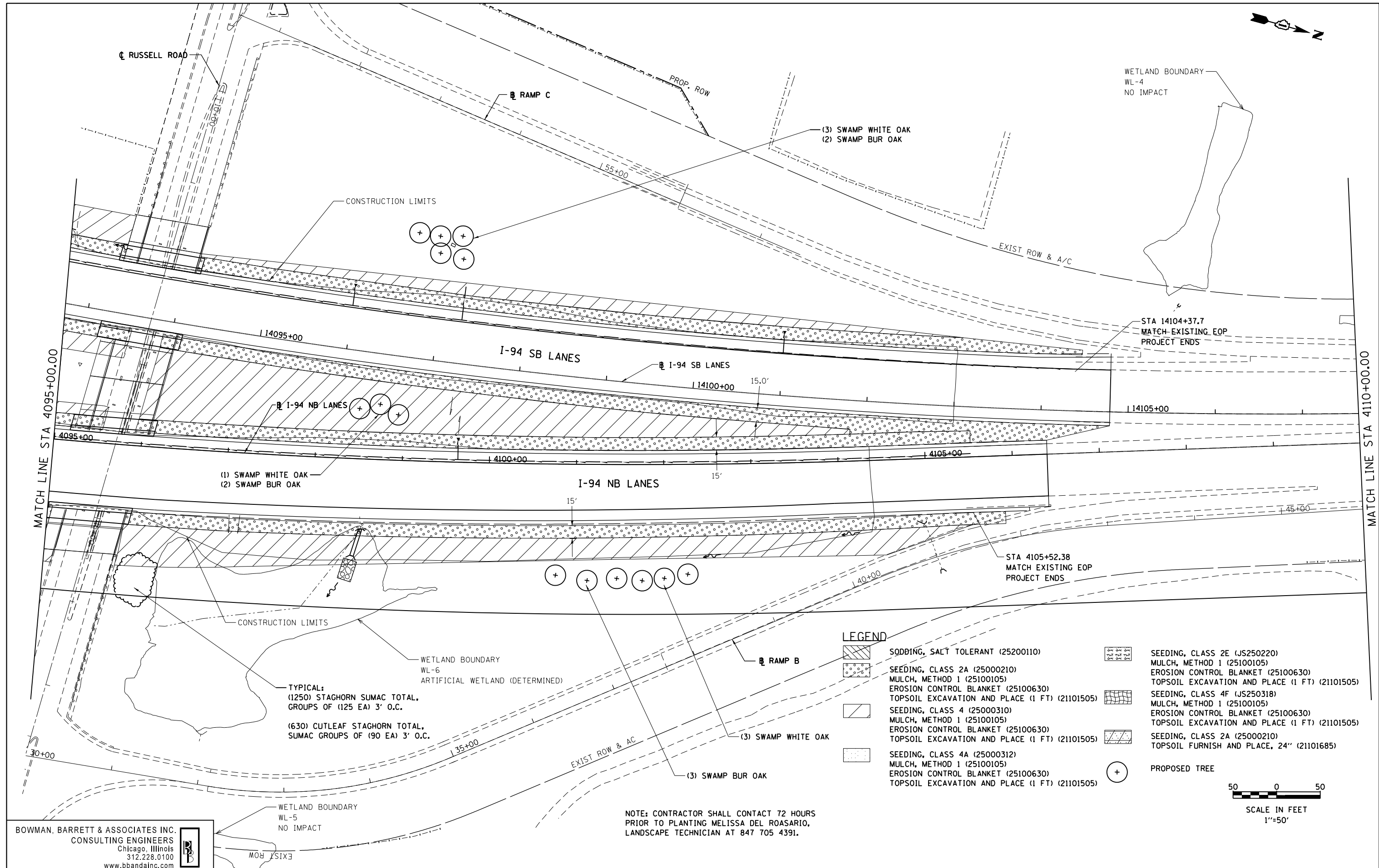

SCALE: 1"=50' SHEET NO. 9 OF 15 SHEETS STA. 4080+00 TO STA. 4095+00

F.A. RTE.	SECTION	COUNTY	TOTAL SHEETS	SHEET NO.
94	49-1-R-1	LAKE	677	313
CONTRACT NO. 60L77				
ILLINOIS FED. AID PROJECT				

S:\1101\95\CADD\60L77_IL_175\60L77_Sheets\0160L77-shr-landscp9.dgn



LEGEND

-  SOODING, SALT TOLERANT (25200110)
-  SEEDING, CLASS 2A (25000210)
MULCH, METHOD 1 (25100105)
EROSION CONTROL BLANKET (25100630)
TOPSOIL EXCAVATION AND PLACE (1 FT) (21101505)
-  SEEDING, CLASS 4 (25000310)
MULCH, METHOD 1 (25100105)
EROSION CONTROL BLANKET (25100630)
TOPSOIL EXCAVATION AND PLACE (1 FT) (21101505)
-  SEEDING, CLASS 4A (25000312)
MULCH, METHOD 1 (25100105)
EROSION CONTROL BLANKET (25100630)
TOPSOIL EXCAVATION AND PLACE (1 FT) (21101505)
-  SEEDING, CLASS 2E (JS250220)
MULCH, METHOD 1 (25100105)
EROSION CONTROL BLANKET (25100630)
TOPSOIL EXCAVATION AND PLACE (1 FT) (21101505)
-  SEEDING, CLASS 4F (JS250318)
MULCH, METHOD 1 (25100105)
EROSION CONTROL BLANKET (25100630)
TOPSOIL EXCAVATION AND PLACE (1 FT) (21101505)
-  SEEDING, CLASS 2A (25000210)
TOPSOIL FURNISH AND PLACE, 24" (21101685)
-  PROPOSED TREE

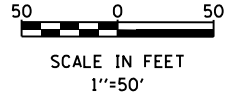

BOWMAN, BARRETT & ASSOCIATES INC.
CONSULTING ENGINEERS
Chicago, Illinois
312.228.0100
www.bbandainc.com

FILE NAME = \$FILES\$	USER NAME = default	DESIGNED - PTG	REVISED -
		DRAWN - PTG	REVISED -
	PLOT SCALE = H=1"=10' V=1"=5'	CHECKED - RGR	REVISED -
	PLOT DATE = 6/20/2012	DATE - 6/19/2012	REVISED -

**STATE OF ILLINOIS
DEPARTMENT OF TRANSPORTATION**







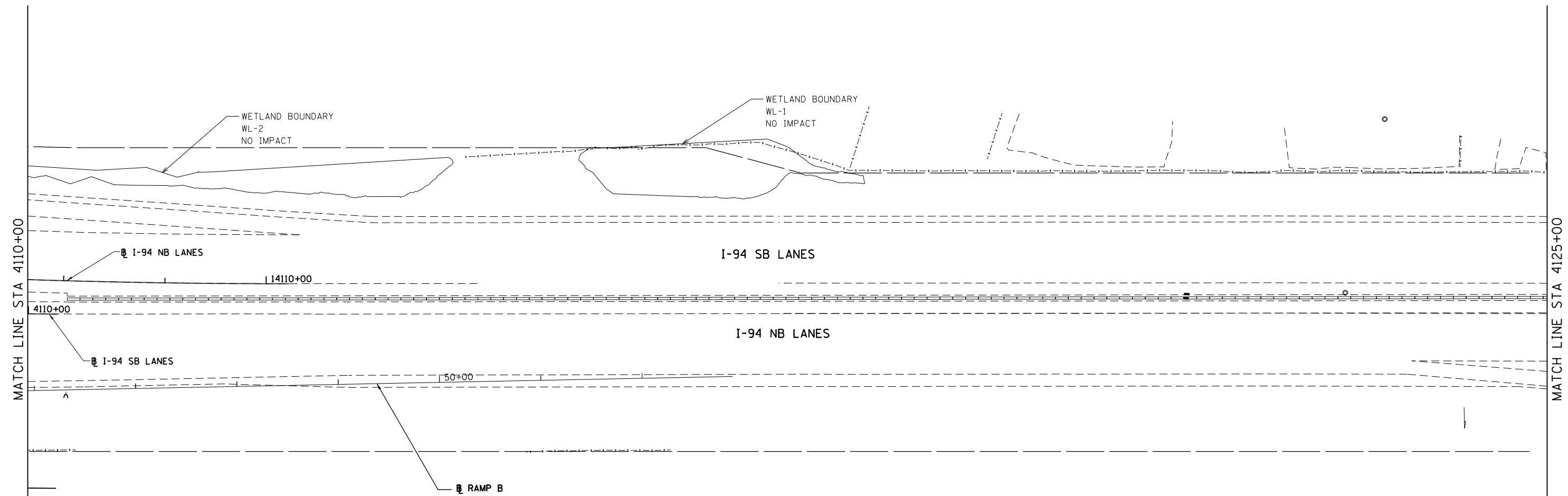

LANDSCAPING PLAN NB I-94 AND SB I-94
SCALE: 1"=50' SHEET NO. 10 OF 15 SHEETS STA. 4095+00 TO STA. 4110+00

F.A. RTE.	SECTION	COUNTY	TOTAL SHEETS	SHEET NO.
94	49-1-R-1	LAKE	677	314
CONTRACT NO. 60L77				
ILLINOIS FED. AID PROJECT				

S:\1101\95-CADD\60L77_IL_175\60L77_Sheets\0160L77-INT-INDSP10.dwg



LEGEND

-  SODDING, SALT TOLERANT (25200110)
-  SEEDING, CLASS 2A (25000210)
MULCH, METHOD 1 (25100105)
EROSION CONTROL BLANKET (25100630)
TOPSOIL EXCAVATION AND PLACE (1 FT) (21101505)
-  SEEDING, CLASS 4 (25000310)
MULCH, METHOD 1 (25100105)
EROSION CONTROL BLANKET (25100630)
TOPSOIL EXCAVATION AND PLACE (1 FT) (21101505)
-  SEEDING, CLASS 4A (25000312)
MULCH, METHOD 1 (25100105)
EROSION CONTROL BLANKET (25100630)
TOPSOIL EXCAVATION AND PLACE (1 FT) (21101505)
-  SEEDING, CLASS 2E (JS250220)
MULCH, METHOD 1 (25100105)
EROSION CONTROL BLANKET (25100630)
TOPSOIL EXCAVATION AND PLACE (1 FT) (21101505)
-  SEEDING, CLASS 4F (JS250318)
MULCH, METHOD 1 (25100105)
EROSION CONTROL BLANKET (25100630)
TOPSOIL EXCAVATION AND PLACE (1 FT) (21101505)
-  SEEDING, CLASS 2A (25000210)
TOPSOIL FURNISH AND PLACE, 24" (21101685)
-  PROPOSED TREE

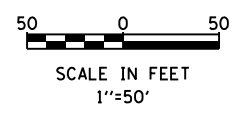

BOWMAN, BARRETT & ASSOCIATES INC.
CONSULTING ENGINEERS
Chicago, Illinois
312.228.0100
www.bbandainc.com



FILE NAME = \$FILES\$	USER NAME = default	DESIGNED - PTG	REVISED -
		DRAWN - PTG	REVISED -
	PLOT SCALE = Hgt=10' Wd=5'	CHECKED - RGR	REVISED -
	PLOT DATE = 6/20/2012	DATE - 6/19/2012	REVISED -

**STATE OF ILLINOIS
DEPARTMENT OF TRANSPORTATION**

LANDSCAPING PLAN NB I-94 AND SB I-94







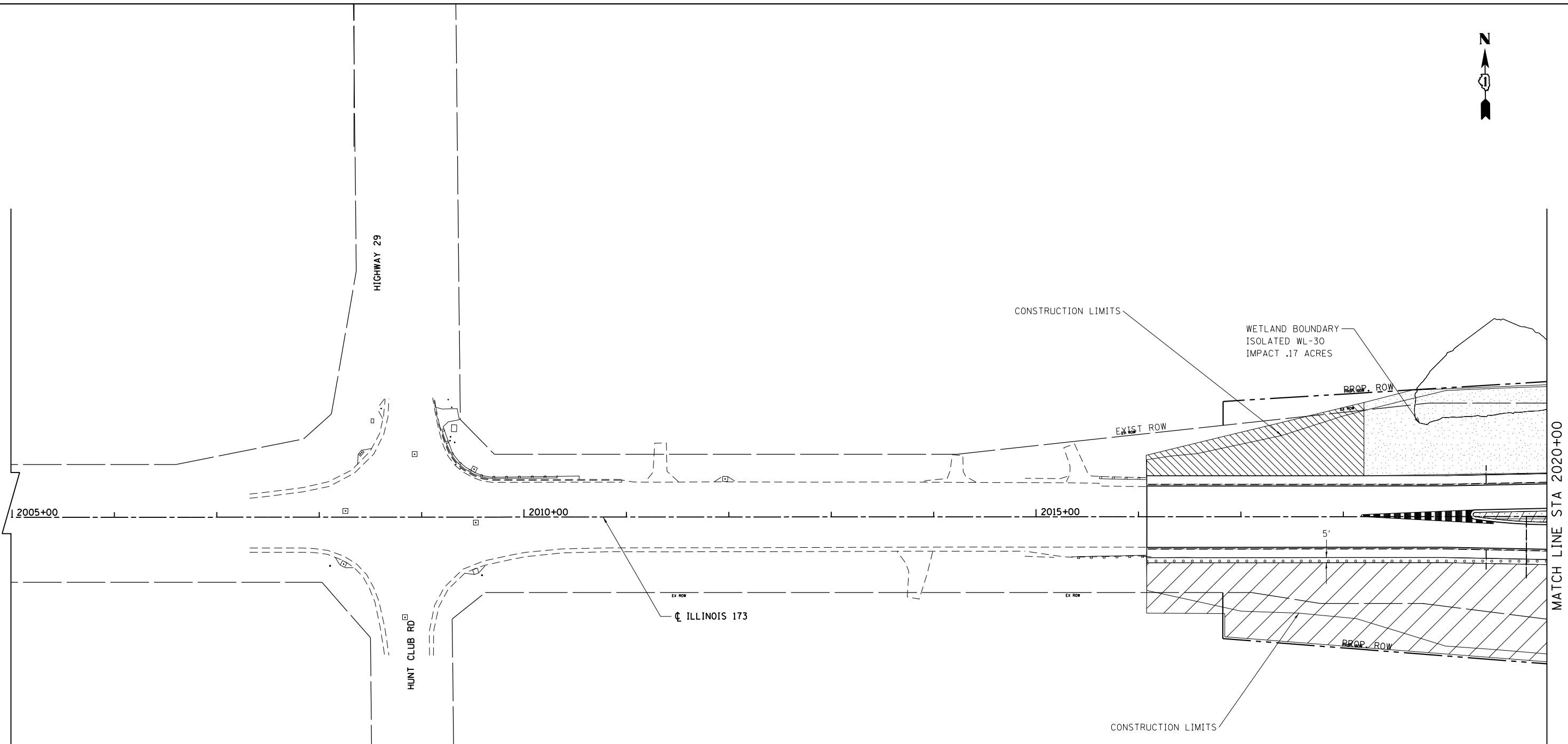
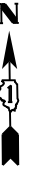

SCALE: 1"=50' SHEET NO. 11 OF 15 SHEETS STA. 4110+00 TO STA. 4125+00

F.A. RTE.	SECTION	COUNTY	TOTAL SHEETS	SHEET NO.
94	49-1-R-1	LAKE	677	315
CONTRACT NO. 60L77			ILLINOIS FED. AID PROJECT	

S:\1101\95-CADD\60L77 IL 175\60L77 Sheets\1160L77-shs-landscpl.dgn



LEGEND

-  SODDING, SALT TOLERANT (25200110)
-  SEEDING, CLASS 2A (25000210)
MULCH, METHOD 1 (25100105)
EROSION CONTROL BLANKET (25100630)
TOPSOIL EXCAVATION AND PLACE (1 FT) (21101505)
-  SEEDING, CLASS 4 (25000310)
MULCH, METHOD 1 (25100105)
EROSION CONTROL BLANKET (25100630)
TOPSOIL EXCAVATION AND PLACE (1 FT) (21101505)
-  SEEDING, CLASS 4A (25000312)
MULCH, METHOD 1 (25100105)
EROSION CONTROL BLANKET (25100630)
TOPSOIL EXCAVATION AND PLACE (1 FT) (21101505)
-  SEEDING, CLASS 2E (JS250220)
MULCH, METHOD 1 (25100105)
EROSION CONTROL BLANKET (25100630)
TOPSOIL EXCAVATION AND PLACE (1 FT) (21101505)
-  SEEDING, CLASS 4F (JS250318)
MULCH, METHOD 1 (25100105)
EROSION CONTROL BLANKET (25100630)
TOPSOIL EXCAVATION AND PLACE (1 FT) (21101505)
-  SEEDING, CLASS 2A (25000210)
TOPSOIL FURNISH AND PLACE, 24" (21101685)
-  PROPOSED TREE

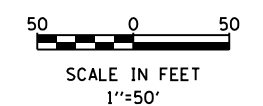

BOWMAN, BARRETT & ASSOCIATES INC.
CONSULTING ENGINEERS
Chicago, Illinois
312.228.0100
www.bbandainc.com



FILE NAME = \$FILES\$	USER NAME = default	DESIGNED - PTG	REVISED -
		DRAWN - PTG	REVISED -
	PLOT SCALE = Hgt=10' Vht=5'	CHECKED - RGR	REVISED -
	PLOT DATE = 6/20/2012	DATE - 6/19/2012	REVISED -

**STATE OF ILLINOIS
DEPARTMENT OF TRANSPORTATION**

LANDSCAPING PLAN IL RTE 173

SCALE: 1"=50' SHEET NO. 12 OF 15 SHEETS STA. 2005+00 TO STA. 2020+00

F.A. RTE.	SECTION	COUNTY	TOTAL SHEETS	SHEET NO.
94	49-1-R-1	LAKE	677	316
CONTRACT NO. 60L77				
ILLINOIS FED. AID PROJECT				

MATCH LINE STA 2020+00

S:\1101\95\CADD\60L77_IL_173\60L77_Sheets\0160L77-INT-Indep12.dwg

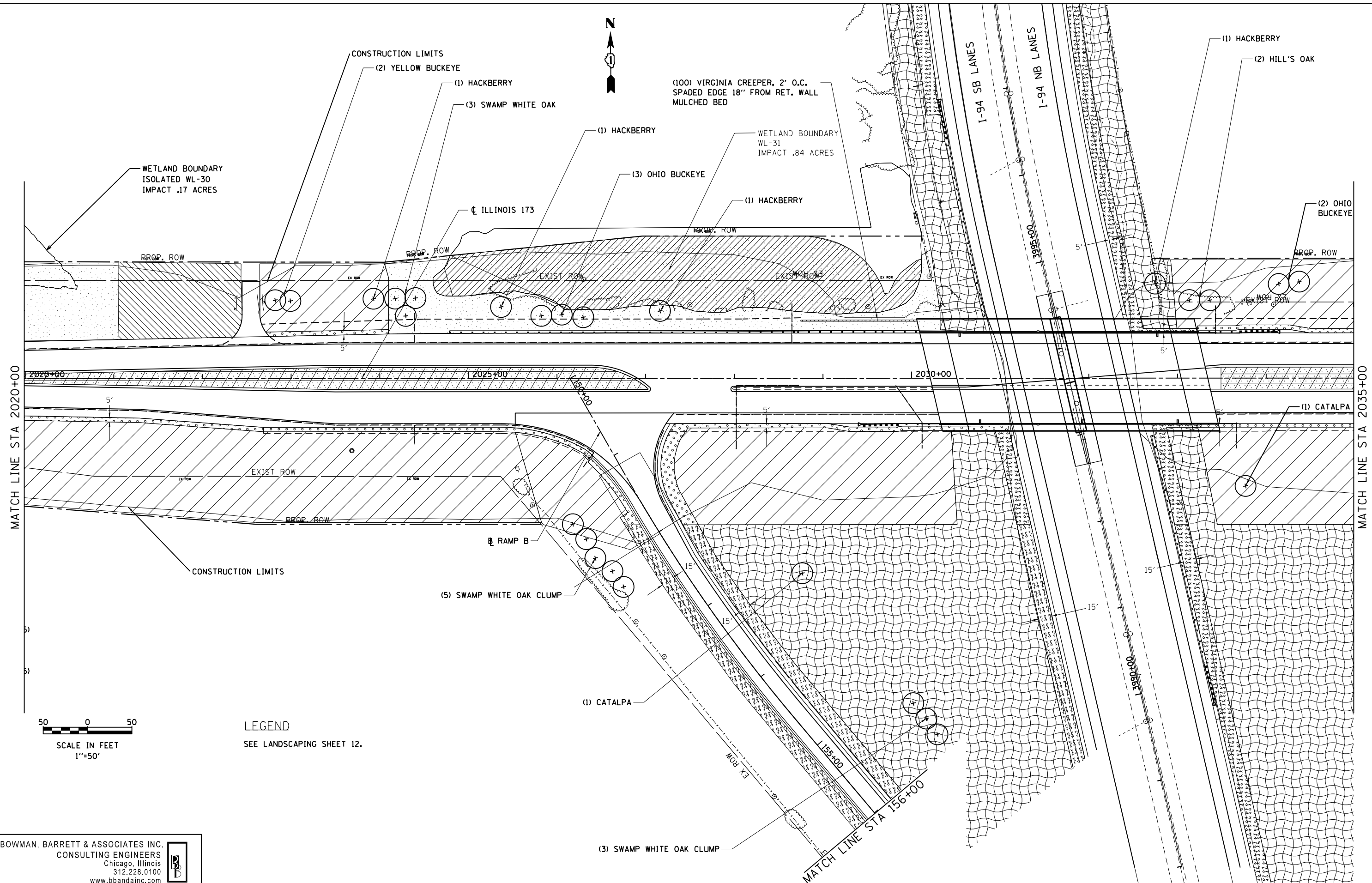

MATCH LINE STA 2020+00

MATCH LINE STA 2035+00

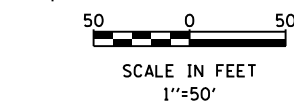

LEGEND
SEE LANDSCAPING SHEET 12.

BOWMAN, BARRETT & ASSOCIATES INC.
CONSULTING ENGINEERS
Chicago, Illinois
312.228.0100
www.bbandainc.com

FILE NAME = \$FILES\$	USER NAME = default	DESIGNED - PTG	REVISED -
		DRAWN - PTG	REVISED -
		CHECKED - RGR	REVISED -
		DATE - 6/19/2012	REVISED -

STATE OF ILLINOIS
DEPARTMENT OF TRANSPORTATION

LANDSCAPING PLAN IL RTE 173

SCALE: 1"=50' SHEET NO. 13 OF 15 SHEETS STA. 2020+00 TO STA. 2035+00

F.A. RTE.	SECTION	COUNTY	TOTAL SHEETS	SHEET NO.
94	49-1-R-1	LAKE	677	317
CONTRACT NO. 60L77				
ILLINOIS FED. AID PROJECT				

S:\1101\95\CADD\60L77_IL_173\60L77_Sheets\0160L77_sht-13.dwg

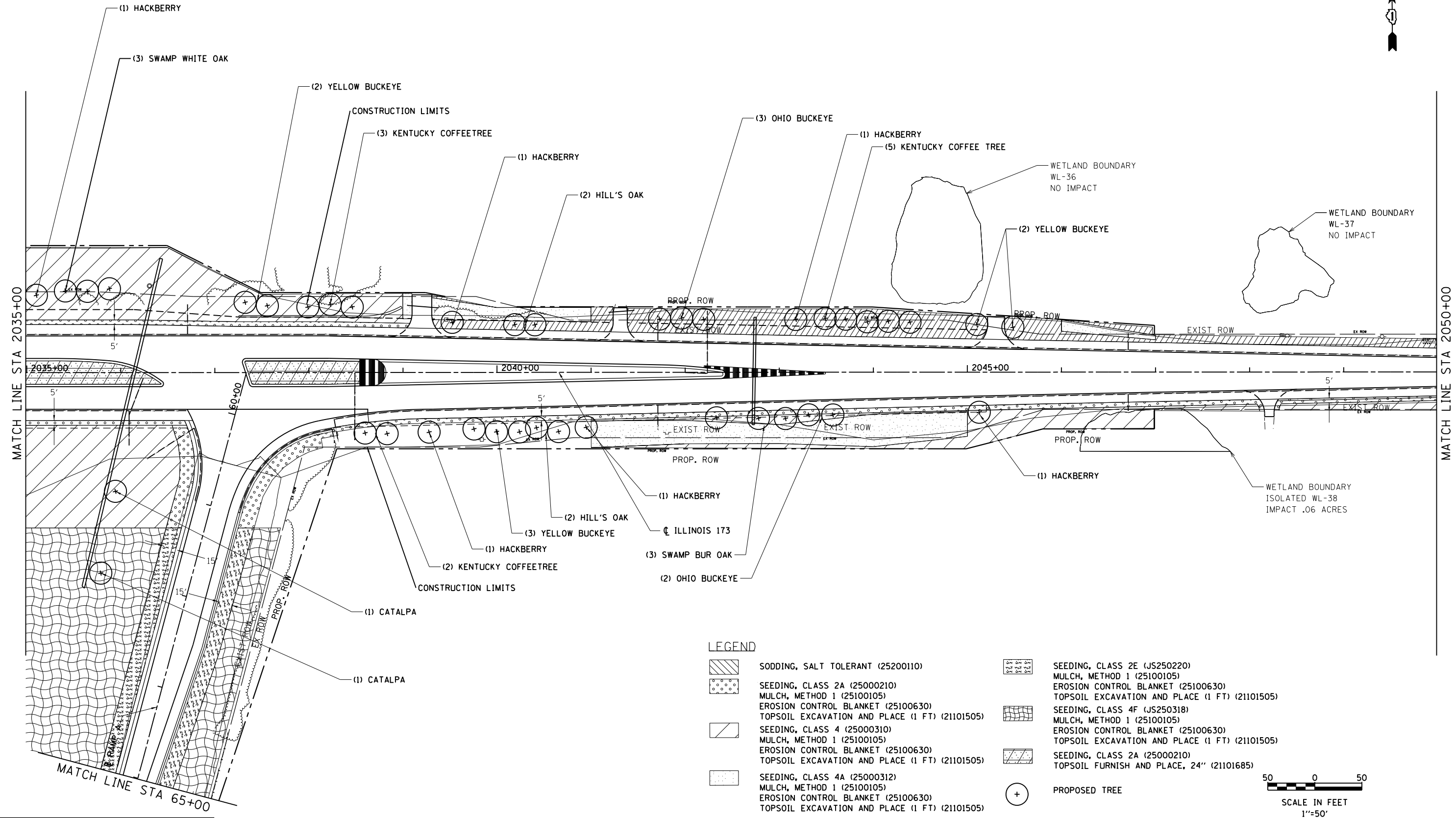
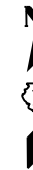

LEGEND

- SODDING, SALT TOLERANT (25200110)
- SEEDING, CLASS 2A (25000210)
MULCH, METHOD 1 (25100105)
EROSION CONTROL BLANKET (25100630)
TOPSOIL EXCAVATION AND PLACE (1 FT) (21101505)
- SEEDING, CLASS 4 (25000310)
MULCH, METHOD 1 (25100105)
EROSION CONTROL BLANKET (25100630)
TOPSOIL EXCAVATION AND PLACE (1 FT) (21101505)
- SEEDING, CLASS 4A (25000312)
MULCH, METHOD 1 (25100105)
EROSION CONTROL BLANKET (25100630)
TOPSOIL EXCAVATION AND PLACE (1 FT) (21101505)
- SEEDING, CLASS 2E (JS250220)
MULCH, METHOD 1 (25100105)
EROSION CONTROL BLANKET (25100630)
TOPSOIL EXCAVATION AND PLACE (1 FT) (21101505)
- SEEDING, CLASS 4F (JS250318)
MULCH, METHOD 1 (25100105)
EROSION CONTROL BLANKET (25100630)
TOPSOIL EXCAVATION AND PLACE (1 FT) (21101505)
- SEEDING, CLASS 2A (25000210)
TOPSOIL FURNISH AND PLACE, 24" (21101685)
- PROPOSED TREE

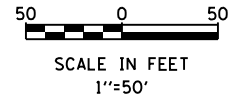

BOWMAN, BARRETT & ASSOCIATES INC.
CONSULTING ENGINEERS
Chicago, Illinois
312.228.0100
www.bbandainc.com

FILE NAME = \$FILES\$	USER NAME = default	DESIGNED - PTG	REVISED -
		DRAWN - PTG	REVISED -
	PLOT SCALE = H=1"=10' V=1"=5'	CHECKED - RGR	REVISED -
	PLOT DATE = 6/20/2012	DATE - 6/19/2012	REVISED -

**STATE OF ILLINOIS
DEPARTMENT OF TRANSPORTATION**

LANDSCAPING PLAN IL RTE 173

SCALE: 1"=50' SHEET NO. 14 OF 15 SHEETS STA. 2035+00 TO STA. 2050+00

F.A. RTE.	SECTION	COUNTY	TOTAL SHEETS	SHEET NO.
94	49-1-R-1	LAKE	677	318
CONTRACT NO. 60L77				
ILLINOIS FED. AID PROJECT				

S:\1101\95\CADD\60L77_IL_173\60L77_Sheets\1160L77-Int-Indep14.dwg







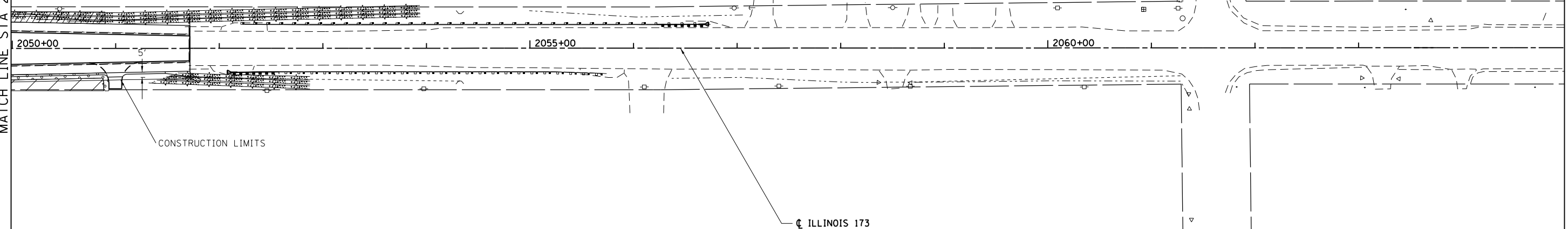



MATCH LINE STA 2050+00

MATCH LINE STA 2065+00



LEGEND

- | | | | |
|---|--|---|--|
|  | SODDING, SALT TOLERANT (25200110) |  | SEEDING, CLASS 2E (JS250220)
MULCH, METHOD 1 (25100105)
EROSION CONTROL BLANKET (25100630)
TOPSOIL EXCAVATION AND PLACE (1 FT) (21101505) |
|  | SEEDING, CLASS 2A (25000210)
MULCH, METHOD 1 (25100105)
EROSION CONTROL BLANKET (25100630)
TOPSOIL EXCAVATION AND PLACE (1 FT) (21101505) |  | SEEDING, CLASS 4F (JS250318)
MULCH, METHOD 1 (25100105)
EROSION CONTROL BLANKET (25100630)
TOPSOIL EXCAVATION AND PLACE (1 FT) (21101505) |
|  | SEEDING, CLASS 4 (25000310)
MULCH, METHOD 1 (25100105)
EROSION CONTROL BLANKET (25100630)
TOPSOIL EXCAVATION AND PLACE (1 FT) (21101505) |  | SEEDING, CLASS 2A (25000210)
TOPSOIL FURNISH AND PLACE, 24" (21101685) |
|  | SEEDING, CLASS 4A (25000312)
MULCH, METHOD 1 (25100105)
EROSION CONTROL BLANKET (25100630)
TOPSOIL EXCAVATION AND PLACE (1 FT) (21101505) |  | PROPOSED TREE |

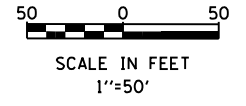

BOWMAN, BARRETT & ASSOCIATES INC.
CONSULTING ENGINEERS
Chicago, Illinois
312.228.0100
www.bbandainc.com



FILE NAME = \$FILES\$	USER NAME = default	DESIGNED - PTG	REVISED -
		DRAWN - PTG	REVISED -
	PLOT SCALE = Hgt=10' Wdt=5'	CHECKED - RGR	REVISED -
	PLOT DATE = 6/20/2012	DATE - 6/19/2012	REVISED -

**STATE OF ILLINOIS
DEPARTMENT OF TRANSPORTATION**

LANDSCAPING PLAN IL RTE 173

SCALE: 1"=50' SHEET NO. 15 OF 15 SHEETS STA. 2050+00 TO STA. 2065+00

F.A. RTE.	SECTION	COUNTY	TOTAL SHEETS	SHEET NO.
94	49-1-R-1	LAKE	677	319
CONTRACT NO. 60L77				
ILLINOIS FED. AID PROJECT				

S:\1101\95-CADD\60L77_IL_173\60L77_Sheets\1160L77-shr-landscp15.dgn

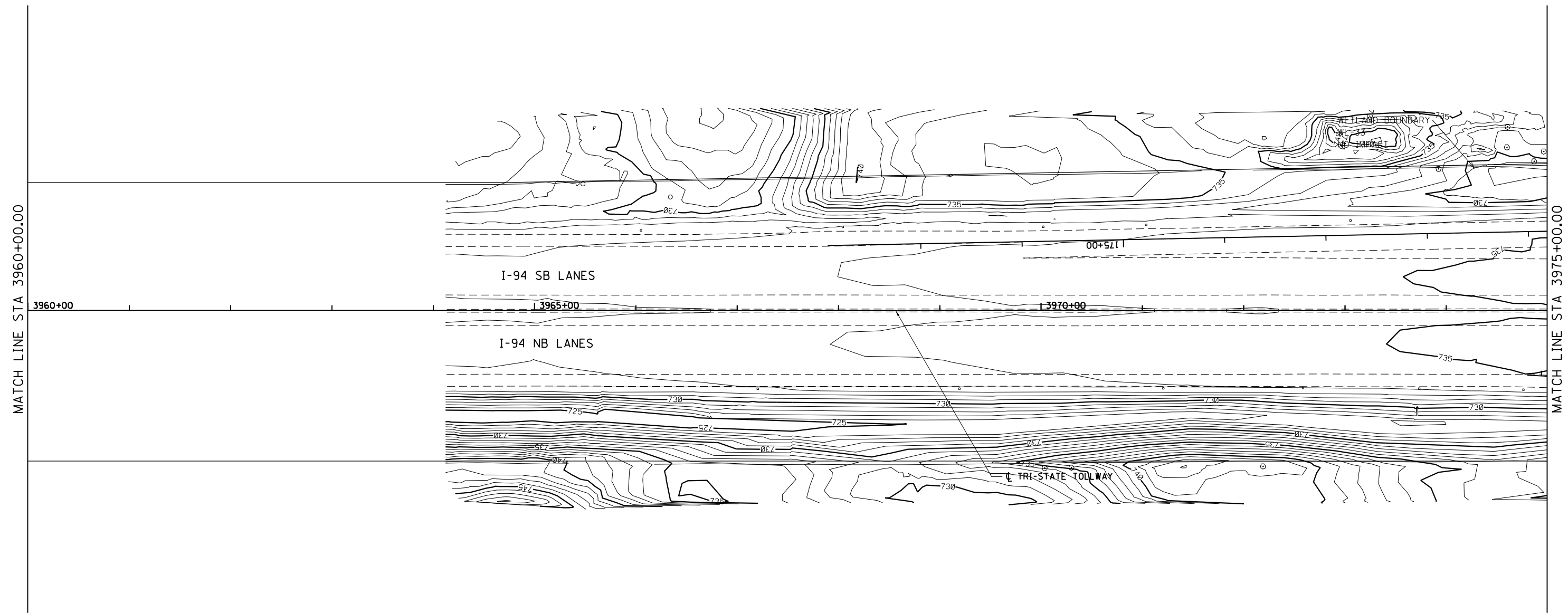

BOWMAN, BARRETT & ASSOCIATES INC.
 CONSULTING ENGINEERS
 Chicago, Illinois
 312.228.0100
 www.bbandainc.com



FILE NAME = \$FILES\$	USER NAME = default	DESIGNED - PTG	REVISED -
		DRAWN - PTG	REVISED -
	PLOT SCALE = Hgt=1/8" Vht=5'	CHECKED - RGR	REVISED -
	PLOT DATE = 6/20/2012	DATE - 6/19/2012	REVISED -

**STATE OF ILLINOIS
 DEPARTMENT OF TRANSPORTATION**

PROPOSED GRADING PLAN

SCALE: 1"=50' SHEET NO. 1 OF 15 SHEETS STA. 3960+00 TO STA. 3975+00

F.A. RTE.	SECTION	COUNTY	TOTAL SHEETS	SHEET NO.
94	49-1-R-1	LAKE	677	320
CONTRACT NO. 60L77				
ILLINOIS FED. AID PROJECT				

S:\1101\95-CADD\60L77 IL 173\60L77 Sheets\0160L77-shr-contour01.dgn

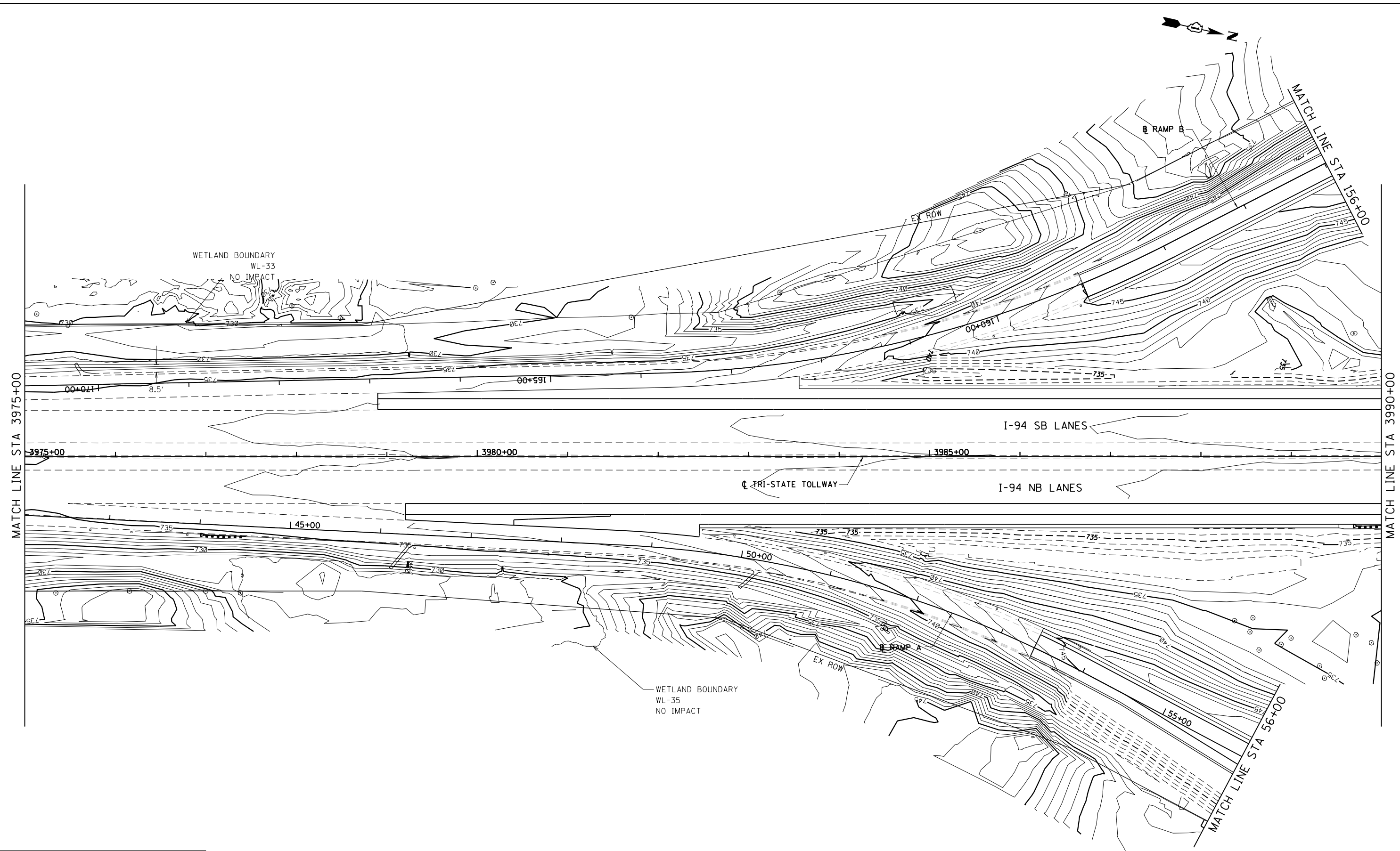

BOWMAN, BARRETT & ASSOCIATES INC.
 CONSULTING ENGINEERS
 Chicago, Illinois
 312.228.0100
 www.bbandainc.com



FILE NAME = #FILES#	USER NAME = default	DESIGNED - PTG	REVISED -
		DRAWN - PTG	REVISED -
	PLOT SCALE = Hgt=10' Vht=5'	CHECKED - RGR	REVISED -
	PLOT DATE = 6/20/2012	DATE - 6/19/2012	REVISED -

**STATE OF ILLINOIS
 DEPARTMENT OF TRANSPORTATION**

PROPOSED GRADING PLAN

SCALE: 1"=50' SHEET NO. 2 OF 15 SHEETS STA. 3975+00 TO STA. 3990+00

F.A. RTE.	SECTION	COUNTY	TOTAL SHEETS	SHEET NO.
94	49-1-R-1	LAKE	677	321
CONTRACT NO. 60L77				
ILLINOIS FED. AID PROJECT				

S:\1101\95-CADD\60L77_IL_175\60L77_Sheets\160L77-shr-contour.dwg

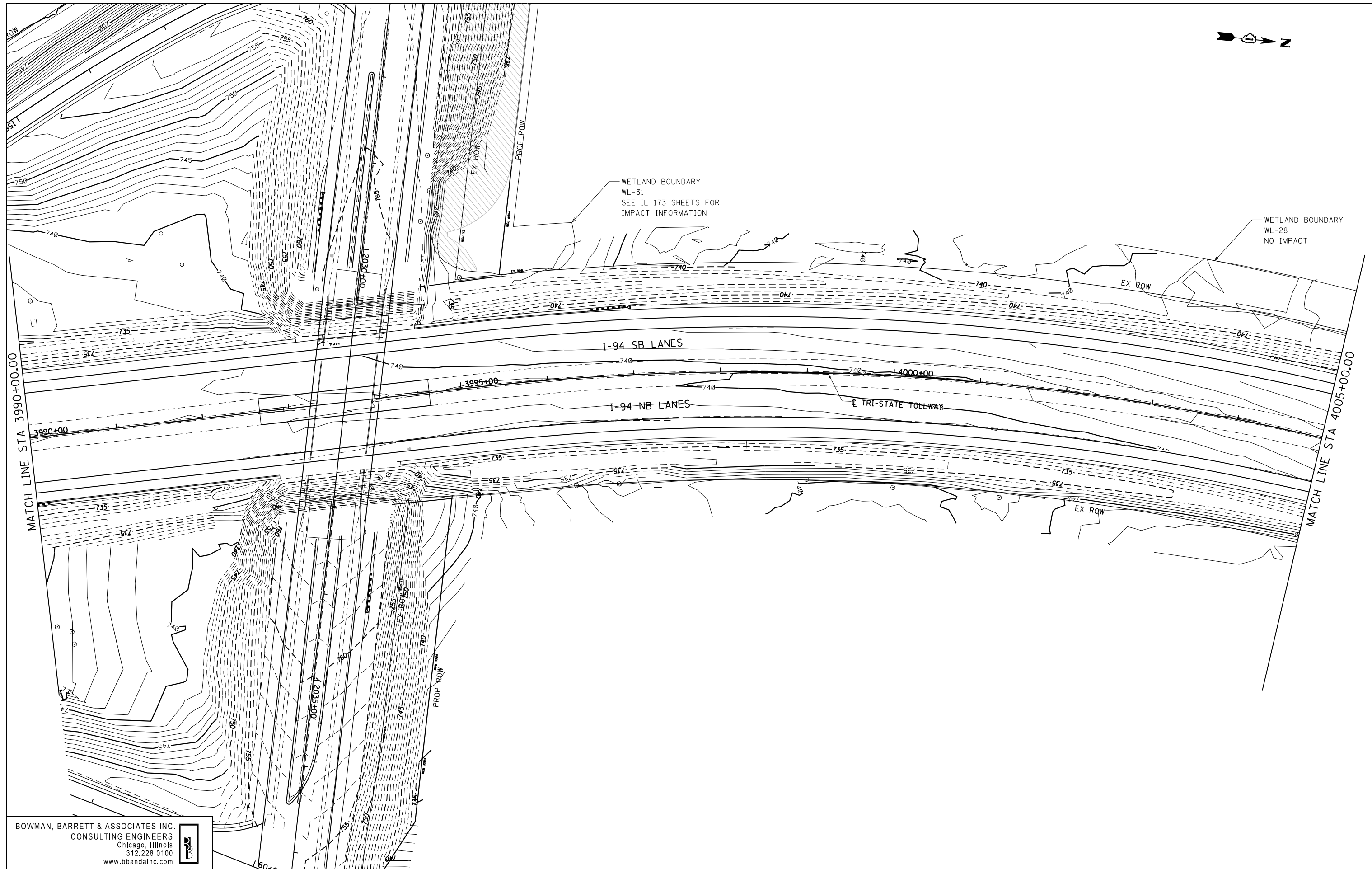

BOWMAN, BARRETT & ASSOCIATES INC.
 CONSULTING ENGINEERS
 Chicago, Illinois
 312.228.0100
 www.bbandainc.com

FILE NAME = \$FILES\$	USER NAME = default	DESIGNED - PTG	REVISED -
		DRAWN - PTG	REVISED -
	PLOT SCALE = H=1"=10' V=1"=5'	CHECKED - RGR	REVISED -
	PLOT DATE = 6/20/2012	DATE - 6/19/2012	REVISED -

**STATE OF ILLINOIS
 DEPARTMENT OF TRANSPORTATION**

PROPOSED GRADING PLAN

SCALE: 1"=50' SHEET NO. 3 OF 15 SHEETS STA. 3990+00 TO STA. 4005+00

F.A. RTE.	SECTION	COUNTY	TOTAL SHEETS	SHEET NO.
94	49-1-R-1	LAKE	677	322
CONTRACT NO. 60L77				
ILLINOIS FED. AID PROJECT				

S:\1101\95\CADD\60L77_IL_173\60L77_Sheets\0160L77-htc-contour03.dgn

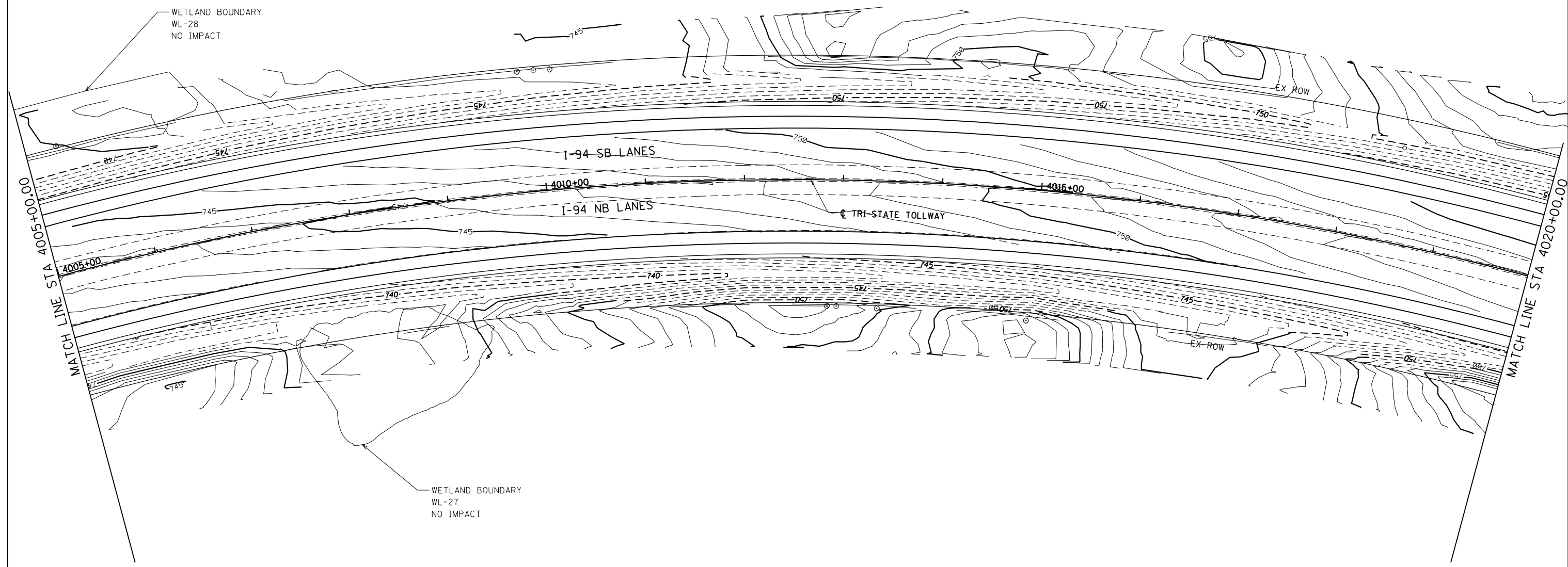

BOWMAN, BARRETT & ASSOCIATES INC.
 CONSULTING ENGINEERS
 Chicago, Illinois
 312.228.0100
 www.bbandainc.com



FILE NAME = \$FILES\$	USER NAME = default	DESIGNED - PTG	REVISED -
		DRAWN - PTG	REVISED -
	PLOT SCALE = Hgt=10' Vht=5'	CHECKED - RGR	REVISED -
	PLOT DATE = 6/20/2012	DATE - 6/19/2012	REVISED -

**STATE OF ILLINOIS
 DEPARTMENT OF TRANSPORTATION**

PROPOSED GRADING PLAN

SCALE: 1"=50' SHEET NO. 4 OF 15 SHEETS STA. 4005+00 TO STA. 4020+00

F.A. RTE.	SECTION	COUNTY	TOTAL SHEETS	SHEET NO.
94	49-1-R-1	LAKE	677	323
CONTRACT NO. 60L77				
ILLINOIS FED. AID PROJECT				

S:\1101\95\CADD\60L77_IL_175\60L77_Sheets\166L77-shr-contour04.dgn

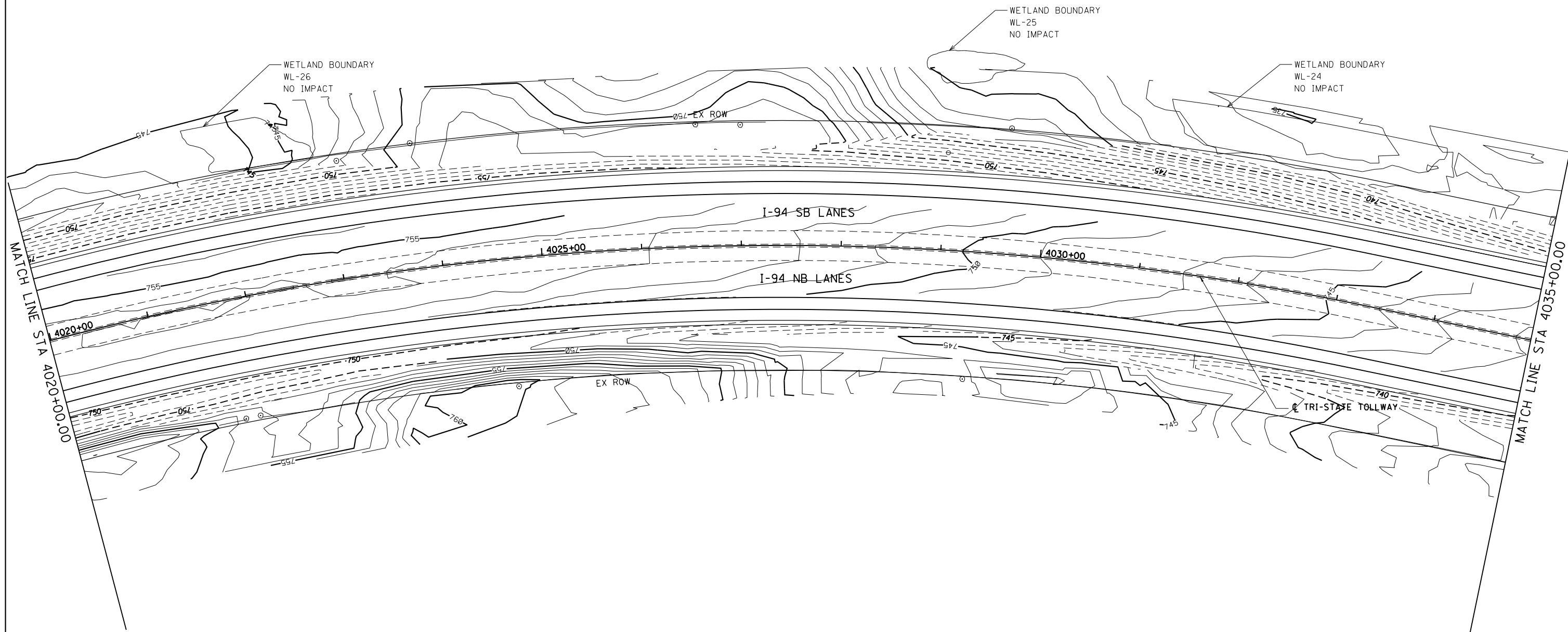
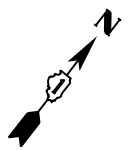

BOWMAN, BARRETT & ASSOCIATES INC.
 CONSULTING ENGINEERS
 Chicago, Illinois
 312.228.0100
 www.bbandainc.com



FILE NAME = \$FILES\$	USER NAME = default	DESIGNED - PTG	REVISED -
		DRAWN - PTG	REVISED -
	PLOT SCALE = H=1"=10' V=1"=5'	CHECKED - RGR	REVISED -
	PLOT DATE = 6/20/2012	DATE - 6/19/2012	REVISED -

**STATE OF ILLINOIS
 DEPARTMENT OF TRANSPORTATION**

PROPOSED GRADING PLAN

SCALE: 1"=50' SHEET NO. 5 OF 15 SHEETS STA. 4020+00 TO STA. 4035+00

F.A. RTE.	SECTION	COUNTY	TOTAL SHEETS	SHEET NO.
94	49-1-R-1	LAKE	677	324
CONTRACT NO. 60L77				
ILLINOIS FED. AID PROJECT				

S:\1101\95\CADD\60L77 IL 175\60L77 Sheets\0160L77-shr-contour.p85.dgn

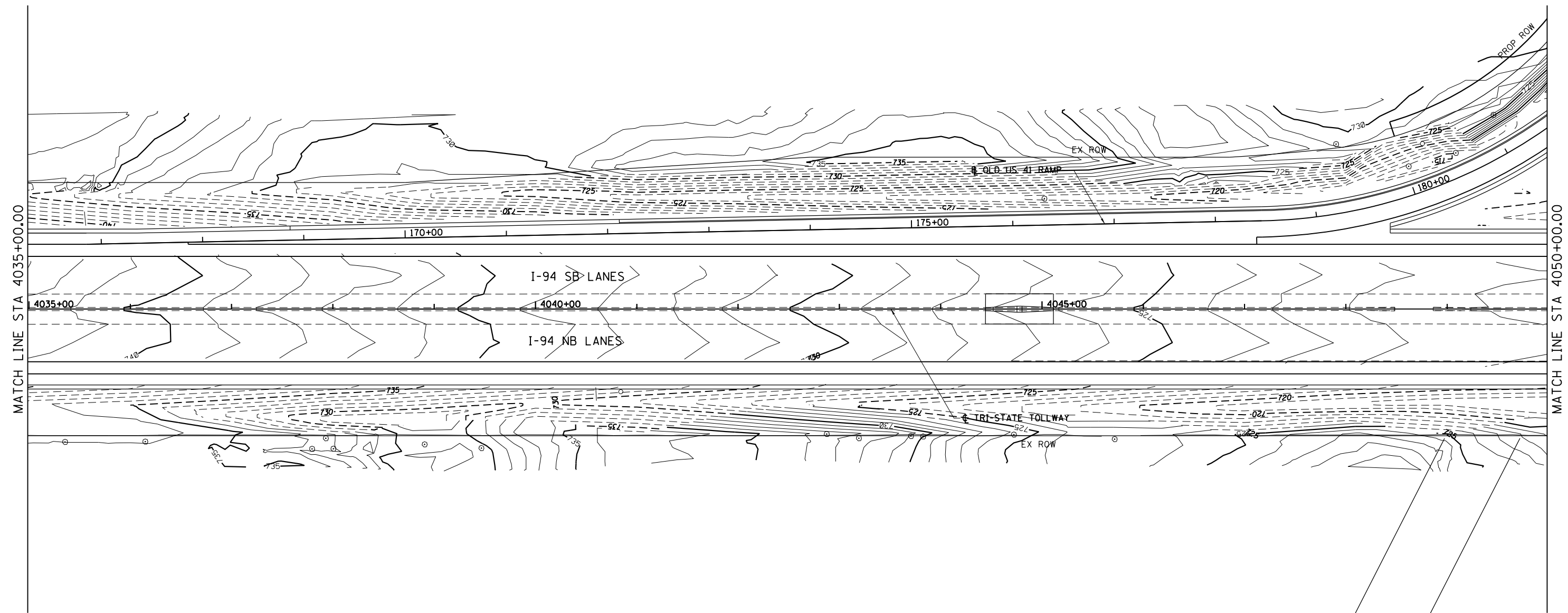

BOWMAN, BARRETT & ASSOCIATES INC.
 CONSULTING ENGINEERS
 Chicago, Illinois
 312.228.0100
 www.bbandainc.com



FILE NAME = \$FILES\$	USER NAME = default	DESIGNED - PTG	REVISED -
		DRAWN - PTG	REVISED -
	PLOT SCALE = Hgt=10' Vht=5'	CHECKED - RGR	REVISED -
	PLOT DATE = 6/20/2012	DATE - 6/19/2012	REVISED -

STATE OF ILLINOIS
DEPARTMENT OF TRANSPORTATION

PROPOSED GRADING PLAN

SCALE: 1"=50' SHEET NO. 6 OF 15 SHEETS STA. 4035+00 TO STA. 4050+00

F.A. RTE.	SECTION	COUNTY	TOTAL SHEETS	SHEET NO.
94	49-1-R-1	LAKE	677	325
CONTRACT NO. 60L77				
ILLINOIS FED. AID PROJECT				

S:\1101\95-CADD\60L77 IL 175\60L77 Sheets\0160L77-shs-contour#66.dgn

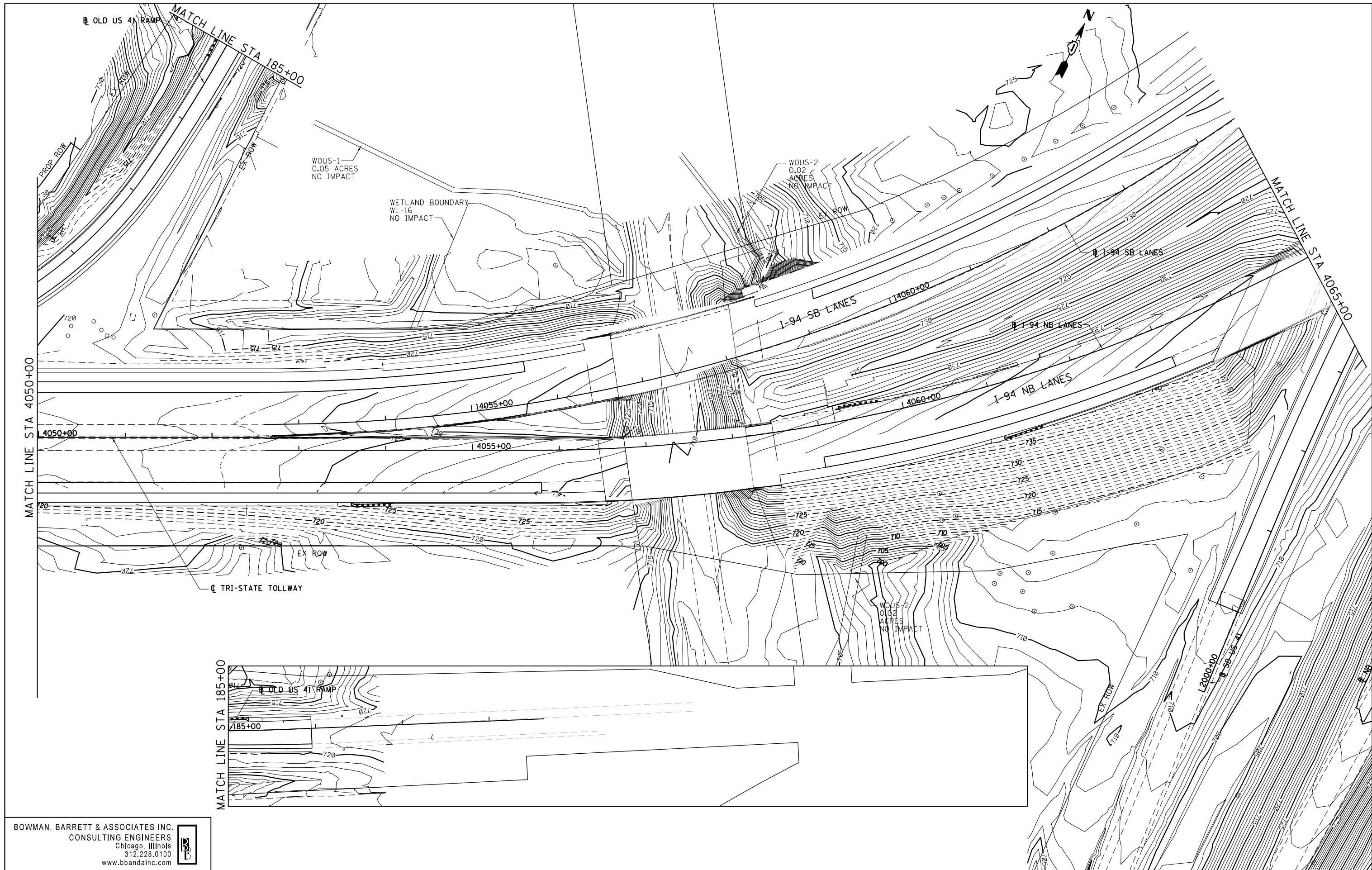

BOWMAN, BARRETT & ASSOCIATES INC.
 CONSULTING ENGINEERS
 Chicago, Illinois
 312.228.0100
 www.bbandainc.com



FILE NAME = \$FILES\$	USER NAME = default	DESIGNED - PTG	REVISED -
		DRAWN - PTG	REVISED -
	PLOT SCALE = Hgt=10' Vgt=5'	CHECKED - RGR	REVISED -
	PLOT DATE = 6/20/2012	DATE - 6/19/2012	REVISED -

**STATE OF ILLINOIS
 DEPARTMENT OF TRANSPORTATION**

PROPOSED GRADING PLAN

SCALE: 1"=50' SHEET NO. 7 OF 15 SHEETS STA. 4050+00 TO STA. 4065+00

F.A. RTE.	SECTION	COUNTY	TOTAL SHEETS	SHEET NO.
94	49-1-R-1	LAKE	677	326
CONTRACT NO. 60L77				
ILLINOIS FED. AID PROJECT				

S:\1101\95\CADD\60L77_IL_175\60L77_Sheets\0160L77-sh-ccontour.dgn

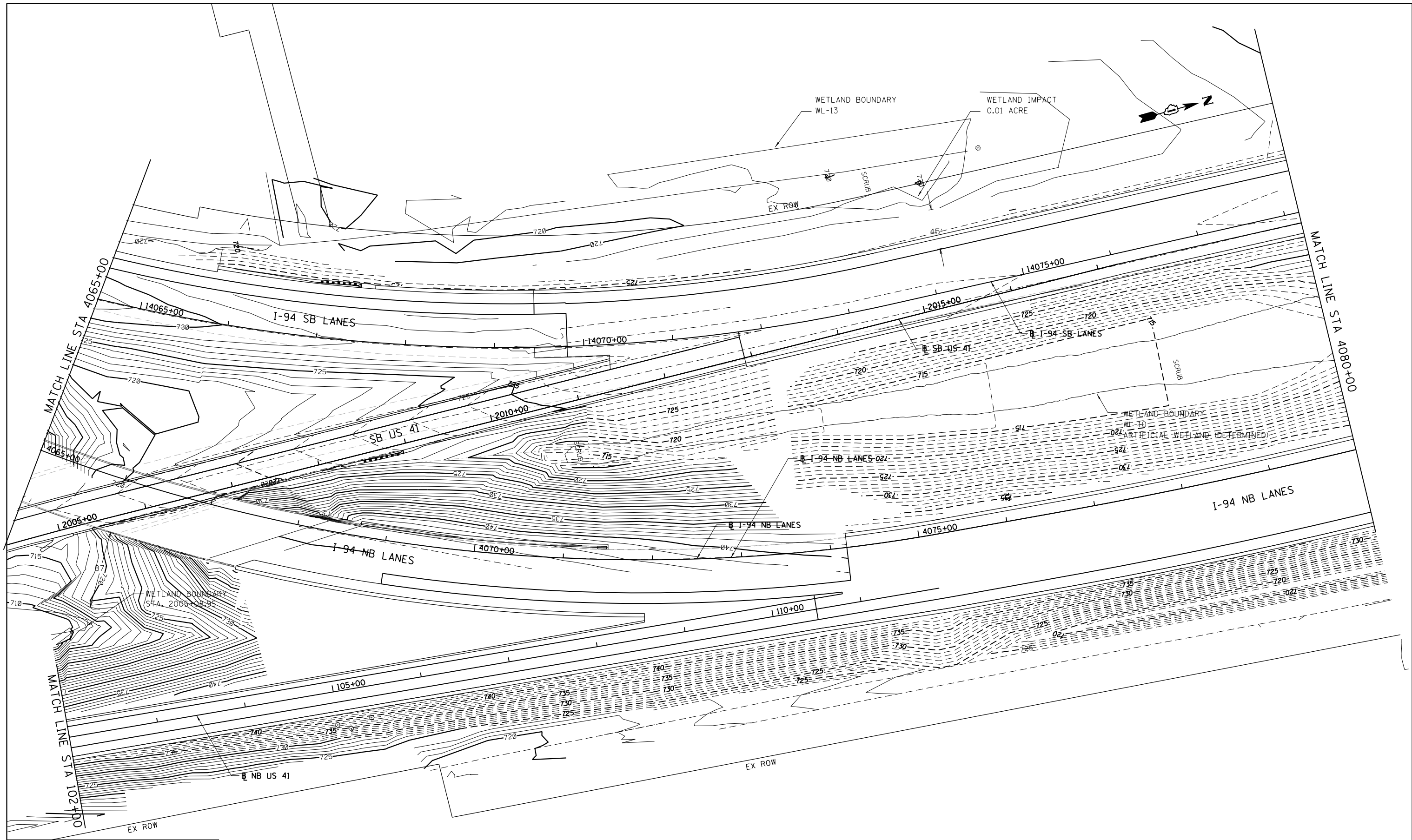

BOWMAN, BARRETT & ASSOCIATES INC.
 CONSULTING ENGINEERS
 Chicago, Illinois
 312.228.0100
 www.bbandainc.com

FILE NAME = #FILES#
 USER NAME = default
 PLOT SCALE = H=1"=10' V=1"=5'
 PLOT DATE = 6/20/2012

DESIGNED - PTG
 DRAWN - PTG
 CHECKED - RGR
 DATE - 6/19/2012

REVISED -
 REVISED -
 REVISED -
 REVISED -

**STATE OF ILLINOIS
 DEPARTMENT OF TRANSPORTATION**

PROPOSED GRADING PLAN

SCALE: SHEET NO. 8 OF 15 SHEETS STA. 4065+00 TO STA. 4078+00

F.A. RTE.	SECTION	COUNTY	TOTAL SHEETS	SHEET NO.
94	49-1-R-1	LAKE	677	327
CONTRACT NO. 60L 77				
ILLINOIS FED. AID PROJECT				

S:\1101\95-CADD\60L77_IL_175\60L77_shts-contour88.dgn

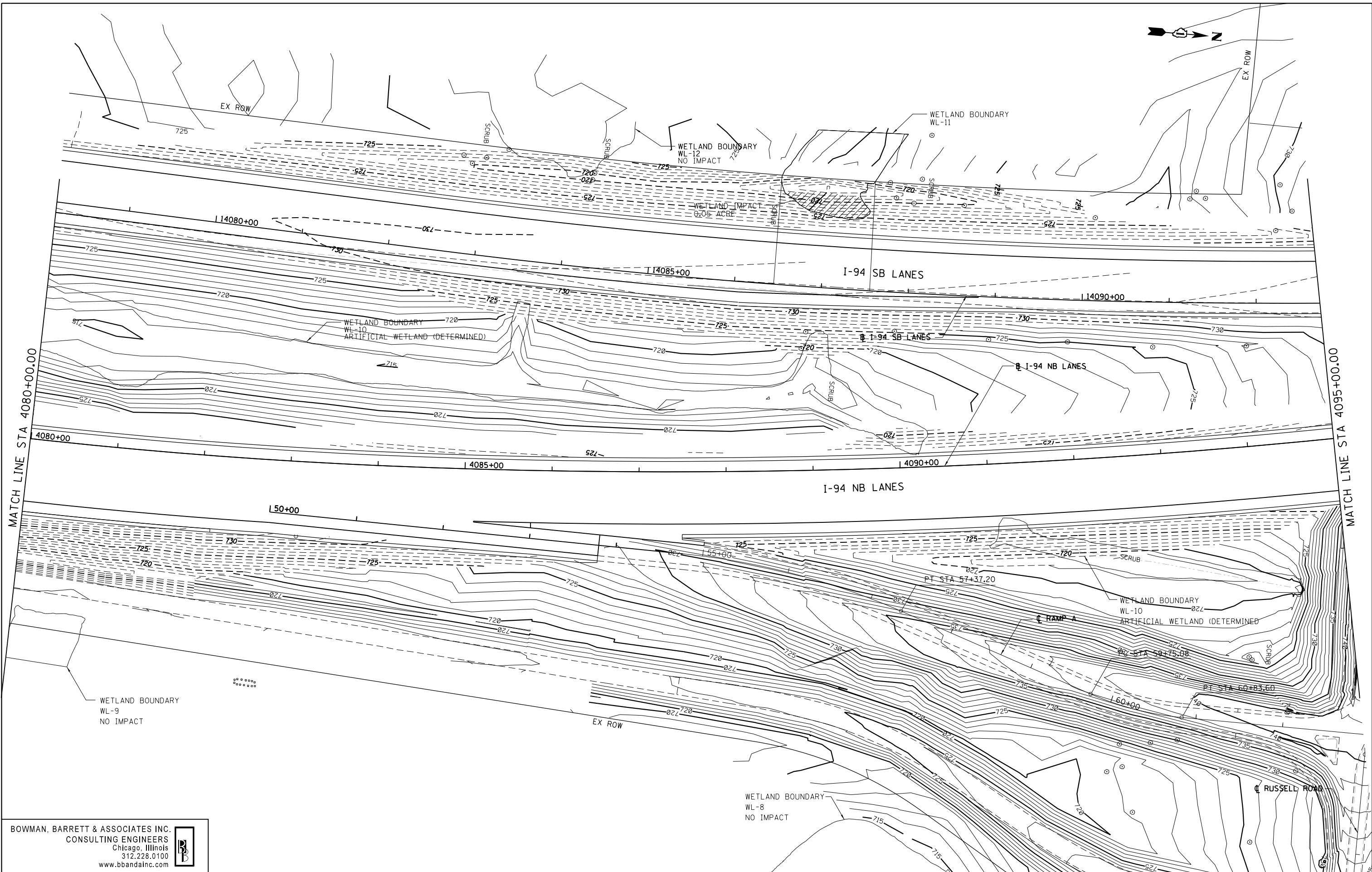

BOWMAN, BARRETT & ASSOCIATES INC.
 CONSULTING ENGINEERS
 Chicago, Illinois
 312.228.0100
 www.bbandainc.com

FILE NAME = \$FILES\$	USER NAME = default	DESIGNED - PTG	REVISED -
		DRAWN - PTG	REVISED -
	PLOT SCALE = Hgt=10' Vht=5'	CHECKED - RGR	REVISED -
	PLOT DATE = 6/20/2012	DATE - 6/19/2012	REVISED -

**STATE OF ILLINOIS
 DEPARTMENT OF TRANSPORTATION**

PROPOSED GRADING PLANS

SCALE: 1"=50' SHEET NO. 9 OF 15 SHEETS STA. 4080+00 TO STA. 4095+00

F.A. RTE.	SECTION	COUNTY	TOTAL SHEETS	SHEET NO.
94	49-1-R-1	LAKE	677	328
CONTRACT NO. 60L77				
ILLINOIS FED. AID PROJECT				

S:\1101\95\CADD\60L77_IL_175\60L77_Sheets\160L77-shr-contour.p09.dgn

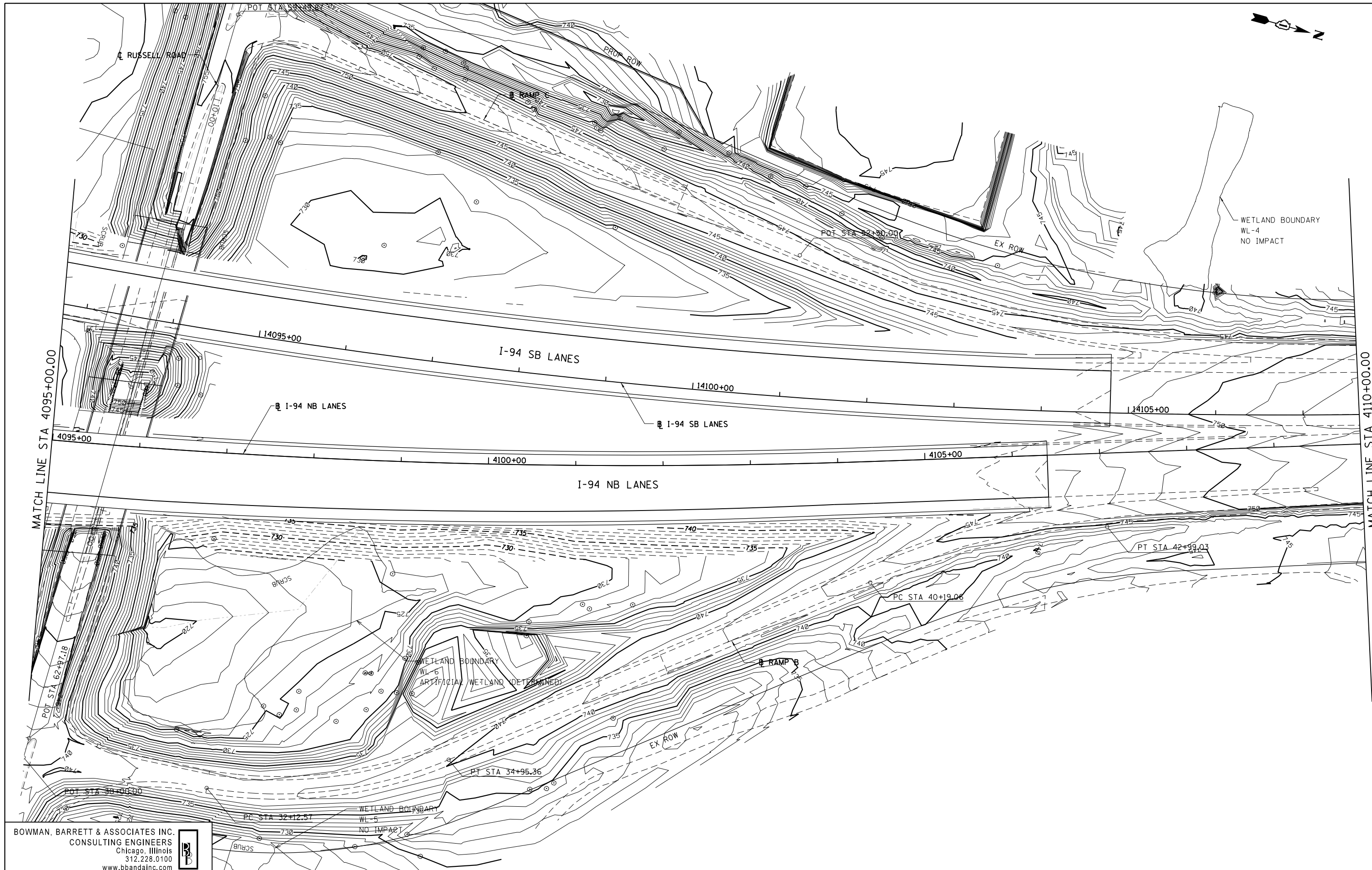

BOWMAN, BARRETT & ASSOCIATES INC.
 CONSULTING ENGINEERS
 Chicago, Illinois
 312.228.0100
 www.bbandainc.com

FILE NAME = \$FILES\$	USER NAME = default	DESIGNED - PTG	REVISED -
		DRAWN - PTG	REVISED -
	PLOT SCALE = H=1"=10' V=1"=5'	CHECKED - RGR	REVISED -
	PLOT DATE = 6/20/2012	DATE = 6/19/2012	REVISED -

**STATE OF ILLINOIS
 DEPARTMENT OF TRANSPORTATION**

PROPOSED GRADING PLAN
 SCALE: 1"=50' SHEET NO. 10 OF 15 SHEETS STA. 4095+00 TO STA. 4110+00

F.A. RTE.	SECTION	COUNTY	TOTAL SHEETS	SHEET NO.
94	49-1-R-1	LAKE	677	329
CONTRACT NO. 60L77				
ILLINOIS FED. AID PROJECT				

S:\1101\95\CADD\60L77_IL_175\60L77_Sheets\0160L77-INT-contour10.dgn

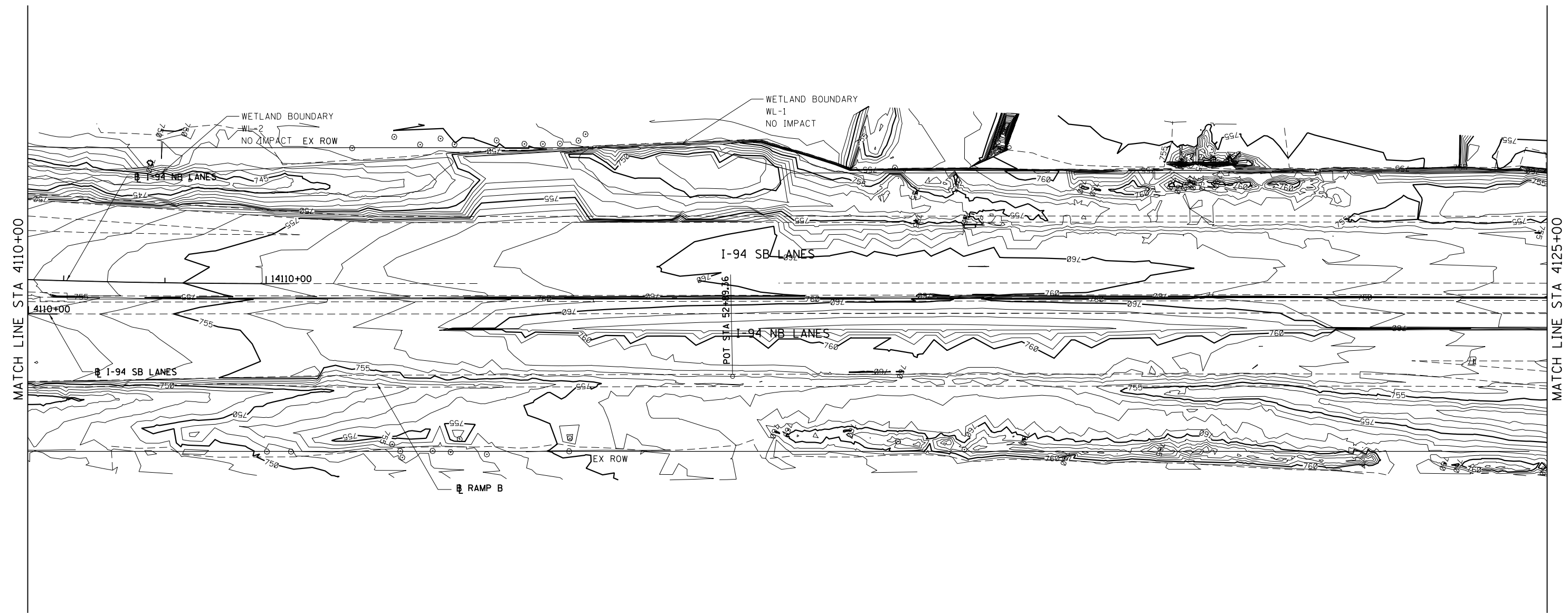

BOWMAN, BARRETT & ASSOCIATES INC.
 CONSULTING ENGINEERS
 Chicago, Illinois
 312.228.0100
 www.bbandainc.com



FILE NAME = \$FILES\$	USER NAME = default	DESIGNED - PTG	REVISED -
		DRAWN - PTG	REVISED -
	PLOT SCALE = Hgt=10' Wdt=5'	CHECKED - RGR	REVISED -
	PLOT DATE = 6/20/2012	DATE - 6/19/2012	REVISED -

STATE OF ILLINOIS
 DEPARTMENT OF TRANSPORTATION

PROPOSED GRADING PLAN

SCALE: 1"=50' SHEET NO. 11 OF 15 SHEETS STA. 4110+00 TO STA. 4125+00

F.A. RTE.	SECTION	COUNTY	TOTAL SHEETS	SHEET NO.
94	49-1-R-1	LAKE	677	330
CONTRACT NO. 60L77				
ILLINOIS FED. AID PROJECT				

S:\1101\95-CADD\60L77 IL 175\60L77 Sheets\0160L77-shr-contour-11.dgn

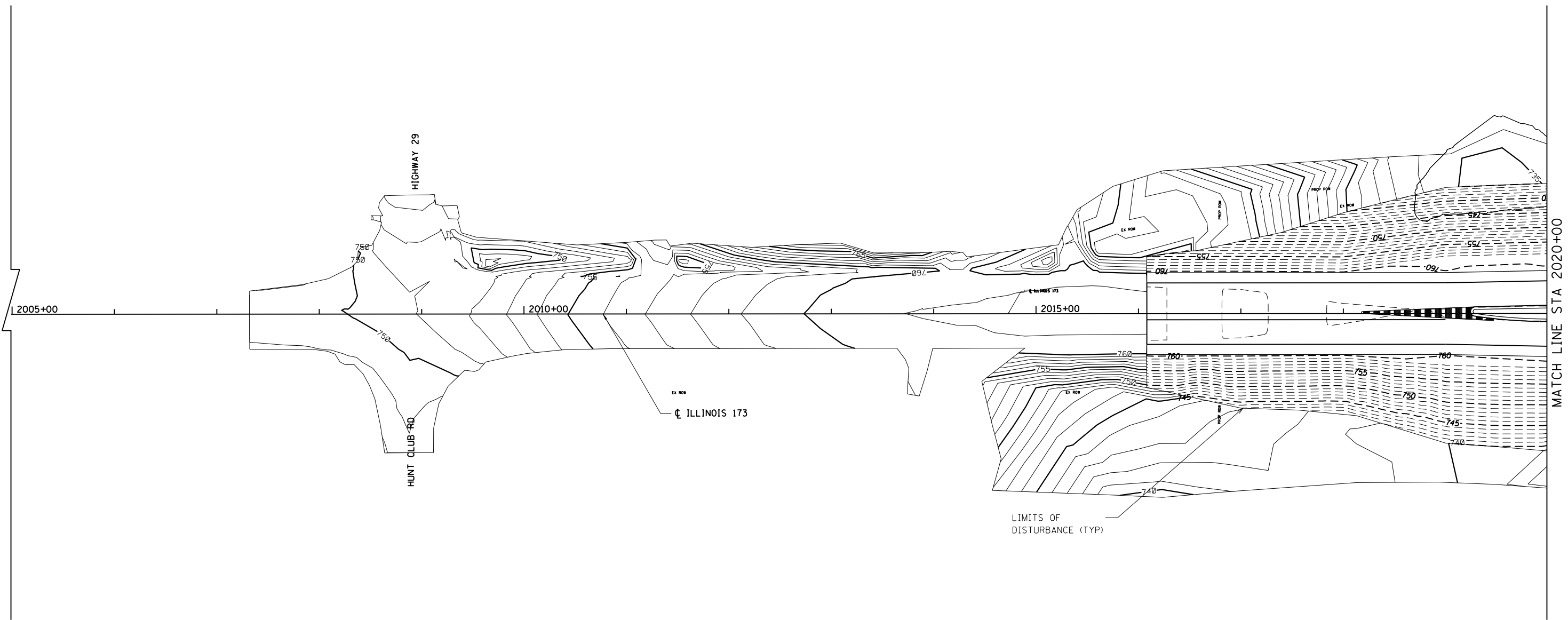

BOWMAN, BARRETT & ASSOCIATES INC.
 CONSULTING ENGINEERS
 Chicago, Illinois
 312.228.0100
 www.bbandainc.com



FILE NAME = \$FILES\$	USER NAME = default	DESIGNED - PTG	REVISED -
		DRAWN - PTG	REVISED -
	PLOT SCALE = Hgt=1/8" Vht=5'	CHECKED - RGR	REVISED -
	PLOT DATE = 6/20/2012	DATE - 6/19/2012	REVISED -

**STATE OF ILLINOIS
 DEPARTMENT OF TRANSPORTATION**

PROPOSED GRADING PLAN IL RTE 173
 SCALE: 1"=50' SHEET NO. 12 OF 15 SHEETS STA. 2005+00 TO STA. 2020+00

F.A. RTE.	SECTION	COUNTY	TOTAL SHEETS	SHEET NO.
94	49-1-R-1	LAKE	677	331
CONTRACT NO. 60L77				
ILLINOIS FED. AID PROJECT				

S:\1101\95\CADD\60L77_IL_173\60L77_Sheets\1160L77-shr-contour12.dgn

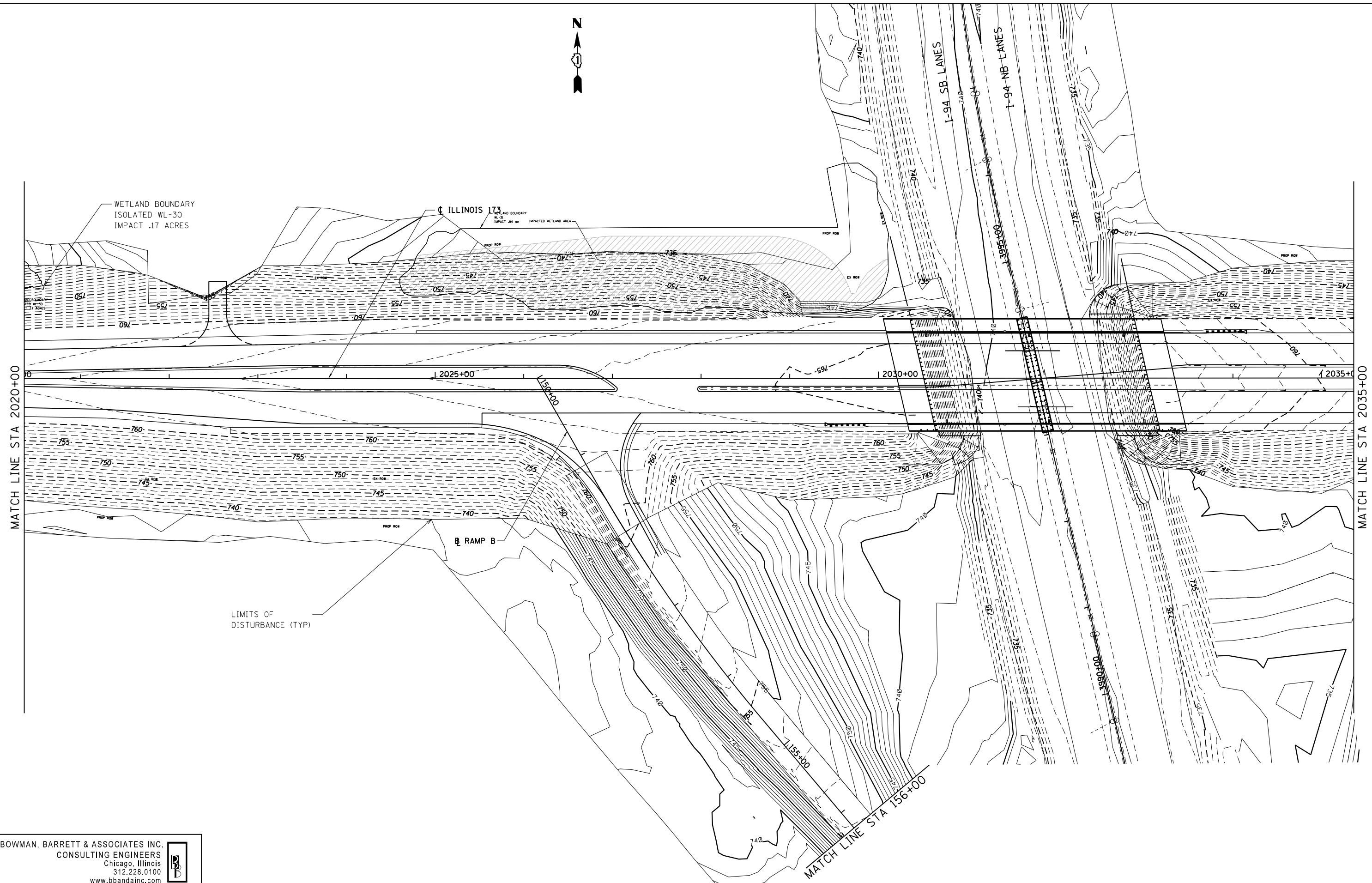

BOWMAN, BARRETT & ASSOCIATES INC.
 CONSULTING ENGINEERS
 Chicago, Illinois
 312.228.0100
 www.bbandainc.com



FILE NAME = \$FILES\$	USER NAME = default	DESIGNED - PTG	REVISED -
		DRAWN - PTG	REVISED -
	PLOT SCALE = Hgt=10' Vht=5'	CHECKED - RGR	REVISED -
	PLOT DATE = 6/20/2012	DATE - 6/19/2012	REVISED -

**STATE OF ILLINOIS
 DEPARTMENT OF TRANSPORTATION**

PROPOSED GRADING PLAN IL RTE 173

SCALE: 1"=50' SHEET NO. 13 OF 15 SHEETS STA. 2020+00 TO STA. 2035+00

F.A. RTE.	SECTION	COUNTY	TOTAL SHEETS	SHEET NO.
94	49-1-R-1	LAKE	677	331A
CONTRACT NO. 60L77				
ILLINOIS FED. AID PROJECT				

S:\1101\95\CADD\60L77_IL_173\60L77_Sheets\0160L77-shs-contour13.dgn

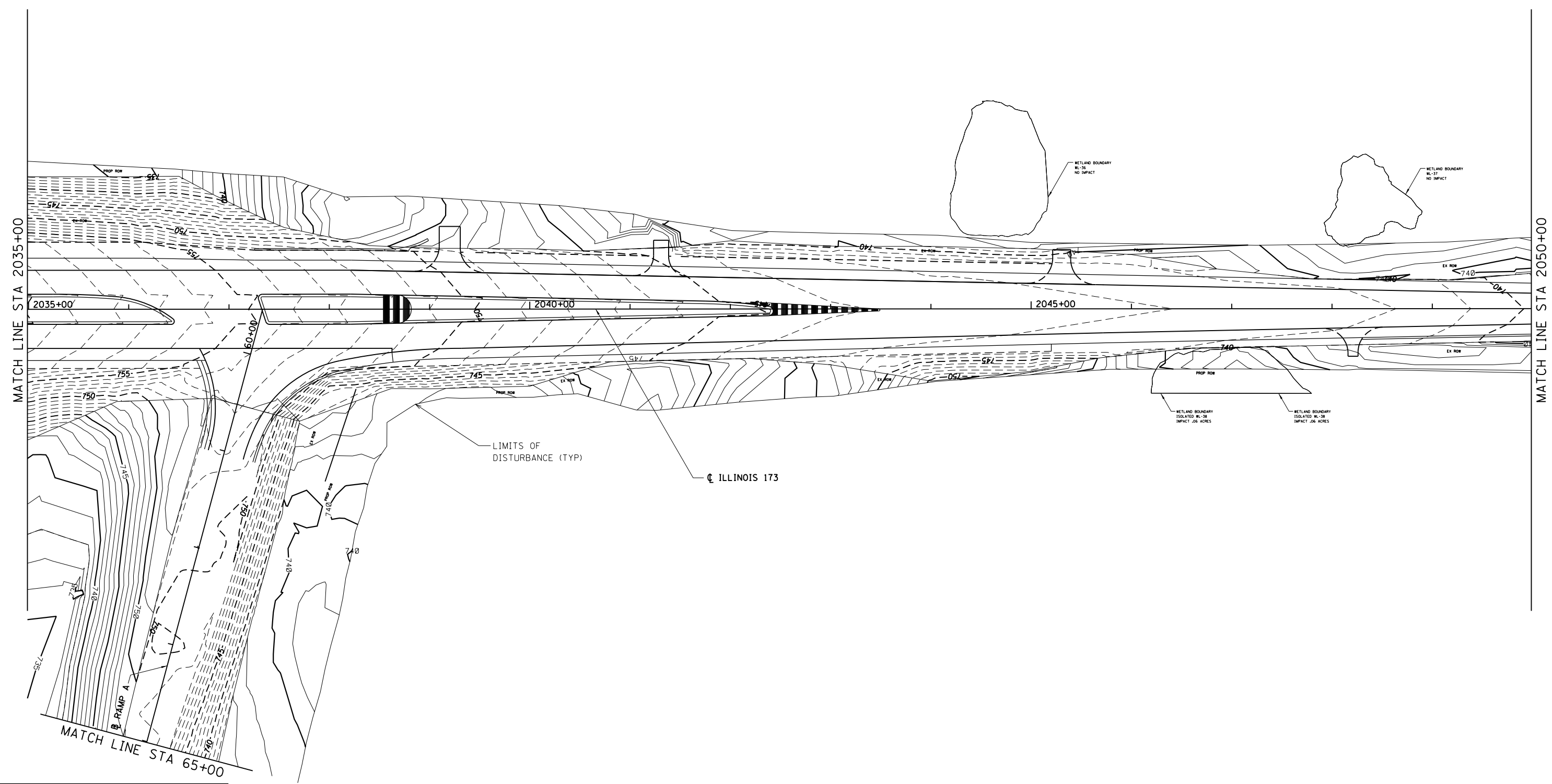

BOWMAN, BARRETT & ASSOCIATES INC.
 CONSULTING ENGINEERS
 Chicago, Illinois
 312.228.0100
 www.bbandainc.com



FILE NAME = \$FILES\$	USER NAME = default	DESIGNED - PTG	REVISED -
		DRAWN - PTG	REVISED -
	PLOT SCALE = Hgt=10' Vgt=5'	CHECKED - RGR	REVISED -
	PLOT DATE = 6/20/2012	DATE - 6/19/2012	REVISED -

**STATE OF ILLINOIS
 DEPARTMENT OF TRANSPORTATION**

PROPOSED GRADING PLAN IL RTE 173

SCALE: 1"=50' SHEET NO. 14 OF 15 SHEETS STA. 2035+00 TO STA. 2050+00

F.A. RTE.	SECTION	COUNTY	TOTAL SHEETS	SHEET NO.
94	49-1-R-1	LAKE	677	331B
CONTRACT NO. 60L77				
ILLINOIS FED. AID PROJECT				

S:\1101\95-CADD\60L77_IL_173\60L77_Sheets\0160L77-shs-contour14.dgn



MATCH LINE STA 2050+00

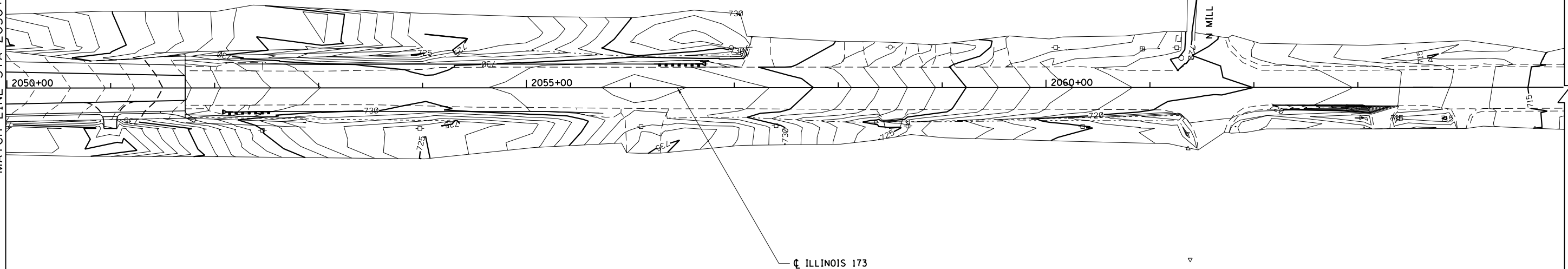

BOWMAN, BARRETT & ASSOCIATES INC.
 CONSULTING ENGINEERS
 Chicago, Illinois
 312.228.0100
 www.bbandainc.com



FILE NAME = \$FILES\$	USER NAME = default	DESIGNED - PTG	REVISED -
		DRAWN - PTG	REVISED -
	PLOT SCALE = Hgt=10' Vht=5'	CHECKED - RGR	REVISED -
	PLOT DATE = 6/20/2012	DATE - 6/19/2012	REVISED -

**STATE OF ILLINOIS
 DEPARTMENT OF TRANSPORTATION**

PROPOSED GRADING PLAN IL RTE 173

SCALE: 1"=50' SHEET NO. 15 OF 15 SHEETS STA. 2050+00 TO STA. 2065+00

F.A. RTE.	SECTION	COUNTY	TOTAL SHEETS	SHEET NO.
94	49-1-R-1	LAKE	677	331C
CONTRACT NO. 60L 77				
ILLINOIS FED. AID PROJECT				

S:\1101\95\CADD\60L77_IL_173\60L77_Sheets\0160L77-shs-contour15.dgn

TRAFFIC SIGNAL SUMMARY OF QUANTITIES

CODE NUMBER	ITEM	UNIT	TOTAL	IL RTE 173 AND I-94 RAMP B			IL RTE 173 AND I-94 RAMP A		IL RTE 173 AND HUNT CLUB ROAD	INTERCONNECT
				Y031 1F	Y031 3D*	LCDOT	Y031 1F	Y031 3D*	Y031 1F	Y031 1F
72000200	SIGN PANEL - TYPE 2	SQ FT	16.25				16.25			
80500020	SERVICE INSTALLATION - POLE MOUNTED	EACH	2	1			1			
81028200	UNDERGROUND CONDUIT, GALVANIZED STEEL, 2" DIA.	FOOT	4,329	621		690	1230	128	1660	
81028210	UNDERGROUND CONDUIT, GALVANIZED STEEL, 2 1/2" DIA.	FOOT	248	83			165			
81028220	UNDERGROUND CONDUIT, GALVANIZED STEEL, 3" DIA.	FOOT	202	39			163			
81028240	UNDERGROUND CONDUIT, GALVANIZED STEEL, 4" DIA.	FOOT	892	374			498	20		
81100600	CONDUIT ATTACHED TO STRUCTURE, 2" DIA., GALVANIZED STEEL	FOOT	325						325	
81400100	HANDHOLE	EACH	4	2			2			
81400200	HEAVY-DUTY HANDHOLE	EACH	13	4		1	4		4	
81400300	DOUBLE HANDHOLE	EACH	4	1			3			
85000200	MAINTENANCE OF EXISTING TRAFFIC SIGNAL INSTALLATION	EACH	1					1		
86400100	TRANSCEIVER - FIBER OPTIC	EACH	3	1			1	1		
87300925	ELECTRIC CABLE IN CONDUIT, TRACER, NO. 14 1C	FOOT	3,844			748			3096	
87301225	ELECTRIC CABLE IN CONDUIT, SIGNAL NO. 14 3C	FOOT	1,617		377	76		1164		
87301245	ELECTRIC CABLE IN CONDUIT, SIGNAL NO. 14 5C	FOOT	5,275	1325			3950			
87301255	ELECTRIC CABLE IN CONDUIT, SIGNAL NO. 14 7C	FOOT	574	574						
87301305	ELECTRIC CABLE IN CONDUIT, LEAD-IN, NO. 14 1 PAIR	FOOT	4,656	2077			2579			
87301805	ELECTRIC CABLE IN CONDUIT, SERVICE, NO. 6 2 C	FOOT	490	106			142	242		
87301900	ELECTRIC CABLE IN CONDUIT, EQUIPMENT GROUNDING CONDUCTOR, NO. 6 1C	FOOT	2,056	757			1071	228		
87502480	TRAFFIC SIGNAL POST, GALVANIZED STEEL 14 FT.	EACH	7	2			5			
87502500	TRAFFIC SIGNAL POST, GALVANIZED STEEL 16 FT.	EACH	1	1						
87700140	STEEL MAST ARM ASSEMBLY AND POLE, 20 FT.	EACH	1				1			
87700230	STEEL MAST ARM ASSEMBLY AND POLE, 38 FT.	EACH	1				1			
87702940	STEEL COMBINATION MAST ARM ASSEMBLY AND POLE 42 FT.	EACH	1				1			
87702990	STEEL COMBINATION MAST ARM ASSEMBLY AND POLE 54 FT.	EACH	1	1						
87702910	STEEL COMBINATION MAST ARM ASSEMBLY AND POLE 36 FT.	EACH	1	1						
87800100	CONCRETE FOUNDATION, TYPE A	FOOT	32	12			20			
87800150	CONCRETE FOUNDATION, TYPE C	FOOT	12	4			4	4		
87800400	CONCRETE FOUNDATION, TYPE E 30-INCH DIAMETER	FOOT	10				10			
87800415	CONCRETE FOUNDATION, TYPE E 36-INCH DIAMETER	FOOT	50	26			24			
87900200	DRILL EXISTING HANDHOLE	EACH	6			1		4	1	
87900205	DRILL EXISTING HEAVY DUTY HANDHOLE	EACH	1					1		
88030020	SIGNAL HEAD, LED, 1-FACE, 3-SECTION, MAST-ARM MOUNTED	EACH	10	4			6			
88030050	SIGNAL HEAD, LED, 1-FACE, 3-SECTION, BRACKET MOUNTED	EACH	9	2			7			
88030110	SIGNAL HEAD, LED, 1-FACE, 5-SECTION, MAST-ARM MOUNTED	EACH	1	1						
88030240	SIGNAL HEAD, LED, 2-FACE, 1-3 SECTION, 1-5 SECTION, BRACKET MOUNTED	EACH	1	1						
88200210	TRAFFIC SIGNAL BACKPLATE, LOUVERED, ALUMINUM	EACH	11	5			6			
88500100	INDUCTIVE LOOP DETECTOR	EACH	14	6			8			
88600700	PREFORMED DETECTOR LOOP	FOOT	1,050	279			771			
89000100	TEMPORARY TRAFFIC SIGNAL INSTALLATION	EACH	2	1			1			
89502300	REMOVE ELECTRIC CABLE FROM CONDUIT	FOOT	250					250		
89502375	REMOVE EXISTING TRAFFIC SIGNAL EQUIPMENT	EACH	3	1			1	1		
89502385	REMOVE EXISTING CONCRETE FOUNDATION	EACH	1					1		
X0324085	EMERGENCY VEHICLE PRIORITY SYSTEM LINE SENSOR CABLE, NO. 20 3/C	FOOT	1,508		378		1130			
85700200	FULL-ACTUATED CONTROLLER AND TYPE IV CABINET	EACH	3	1			1	1		
X8620200	UNINTERRUPTABLE POWER SUPPLY, SPECIAL	EACH	3	1			1	1		
X8710024	FIBER OPTIC CABLE IN CONDUIT, NO. 62.5/125, MM12F SM24F	FOOT	3,844			748			3096	
X8730800	ELECTRIC CABLE IN CONDUIT, VIDEO, NO. 20 4 C	FOOT	76			76				
X8950115	RELOCATE LIGHT DETECTOR	EACH	5	2			3			
X8950120	RELOCATE LIGHT DETECTOR AMPLIFIER	EACH	2	1			1			
Z0033056	OPTIMIZE TRAFFIC SIGNAL SYSTEM	EACH	1						1	
Z0073510	TEMPORARY TRAFFIC SIGNAL TIMING	EACH	2	1			1			
	RELOCATE WIRELESS INTERCONNECT (COMPLETE)	L SUM	1						1	
XX005940	REMOTE-CONTROLLED VIDEO SYSTEM	EACH	1			1				
XX007952	TERMINAL SERVER	EACH	1			1				
XX008253	VIDEO ENCODER	EACH	1			1				
	ELECTRIC CABLE IN CONDUIT, COAXIAL	FOOT	76			76				
X0327211	RELOCATE SWITCH	EACH	1			1				
	RELOCATE VIDEO VEHICLE DETECTION SYSTEM	EACH	2	1			1			
	ELECTRIC CABLE, COMMUNICATION, NO.22 4 PAIR	FOOT	942			942				

S:\Projects\3031 US 41-Wise to IL 173 - BBA\Project Work\Disciplines\Traffic Signals\Sheet\060777-811-tt-01.dgn



FILE NAME =	USER NAME = grai	DESIGNED - GR	REVISED -
		DRAWN - GR	REVISED -
	PLOT SCALE = none	CHECKED - BKS	REVISED -
	PLOT DATE = 6/18/2012	DATE - 06/19/2012	REVISED -

**STATE OF ILLINOIS
DEPARTMENT OF TRANSPORTATION**

TRAFFIC SIGNAL SUMMARY OF QUANTITIES			
IL RTE 173 AT I-94			
SCALE: NONE	SHEET NO. 1 OF 1 SHEETS	STA.	TO STA.

F.A.I. RTE. 94	SECTION 49-1-R-1	COUNTY LAKE	TOTAL SHEETS 677	SHEET NO. 332
CONTRACT NO. 60L77			ILLINOIS FED. AID PROJECT	

TS-01

LOOP DETECTOR NOTES

- EACH PAIR OF LOOP WIRES SHALL BE PLACED IN A SEPARATE EMPTY COILABLE NONMETALLIC CONDUIT FROM THE EDGE OF PAVEMENT TO THE HANDHOLE. SPACING BETWEEN THE HOLES DRILLED IN THE PAVEMENT SHALL NOT BE LESS THAN 6" (150 mm). EMPTY COILABLE NONMETALLIC CONDUIT SHALL BE INCLUDED IN THE COST OF THE LOOP WIRE.
- THE NUMBER OF LOOP TURNS SHALL BE AS RECOMMENDED BY THE AMPLIFIER MANUFACTURER. ALL ADJACENT SIDES OF THE LOOPS SHALL BE INSTALLED IN SUCH A WAY THAT THE CURRENT FLOW IS IN THE SAME DIRECTION TO REINFORCE ITS MAGNETIC FIELDS FOR SMALL VEHICLE DETECTION.
- EACH LOOP LEAD-IN SHALL BE IDENTIFIED AND PERMANENTLY TAGGED IN THE HANDHOLE. EACH LEAD-IN CABLE TAG SHALL INDICATE THE LOCATION OF THE LOOP, LOOP ROTATION (CLOCKWISE/COUNTERCLOCKWISE), LOOP LEAD-IN DIRECTION (IN OR OUT), LOOP CABLE NUMBER AND LOCATION IN CABINET, AND NUMBER OF TURNS IN THE DETECTOR LOOPS IN WATER PROOF INK AS INDICATED ON THE DISTRICT 1 STANDARD TRAFFIC SIGNAL DESIGN DETAIL. THE CONTRACTOR SHALL MARK LOOP LOCATIONS ON RECORD DRAWINGS AND PRESENT TO THE ENGINEER AFTER FINAL INSPECTION. LOOPS SHALL BE MARKED BY LANE AND LOOP NUMBER. SEE DETAIL BELOW.
- ALL LOOP CABLE SHALL BE FASTENED WITH PLASTIC TIE WRAP TO THE HANDHOLE HOOKS.
- IN ASPHALT PAVEMENT, LOOPS SHOULD BE PLACED IN THE BINDER AND DIVEHOLES MARKED AT THE CURB WITH A SAW-CUT. THE SAW-CUT SHALL BE CUT IN ACCORDANCE WITH LOCAL AND E.P.A. DUST CONTROL REQUIREMENTS. DETECTOR LOOP(S) SHALL NOT BE INSTALLED IN WET CONDITIONS AND THE SAW-CUTS MUST BE FREE OF DEBRIS AND RESIDUE SUCH AS DUST AND WATER WHICH IS TO BE ACHIEVED BY THE USE OF COMPRESSED AIR, WIRE BRUSHING AND HEAT DRYING ACCORDING TO SEALANT MANUFACTURER REQUIREMENTS. THE DETECTOR WIRE SHALL BE HELD IN PLACE BY THE USE OF FORM WEDGES. WEDGES SHALL BE SPACED NO MORE THAN 18" (450 mm) APART.
- LOOP SPLICES SHALL BE SOLDERED USING A SOLDERING IRON. BLOW TORCHES OR OTHER DEVICES WHICH OXIDIZE COPPER CABLE SHALL NOT BE ALLOWED FOR SOLDERING OPERATIONS. SEE DETAIL BELOW RIGHT.
- PREFORMED DETECTOR LOOPS SHALL BE USED, AS SHOWN ON THE PLANS, WHERE NEW CONCRETE PAVEMENT IS PROPOSED. THE INSTALLATION OF PREFORMED LOOPS SHALL BE IN ACCORDANCE WITH THE DISTRICT 1 SPECIFICATIONS OR AS DIRECTED BY THE ENGINEER.

LOOP LEAD-IN CABLE TAG

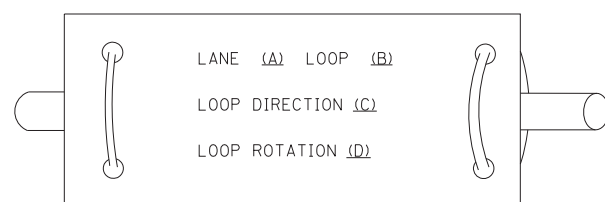

- LANE 1 IS THE LANE CLOSEST TO THE CENTERLINE OF THE ROADWAY
- LOOP #1 IS THE LOOP IN THE LANE CLOSEST TO THE INTERSECTION.
- LABEL LOOP CABLE "IN" OR LOOP CABLE "OUT".
- LABEL LOOP CABLE CLOCKWISE OR LOOP CABLE COUNTERCLOCKWISE.

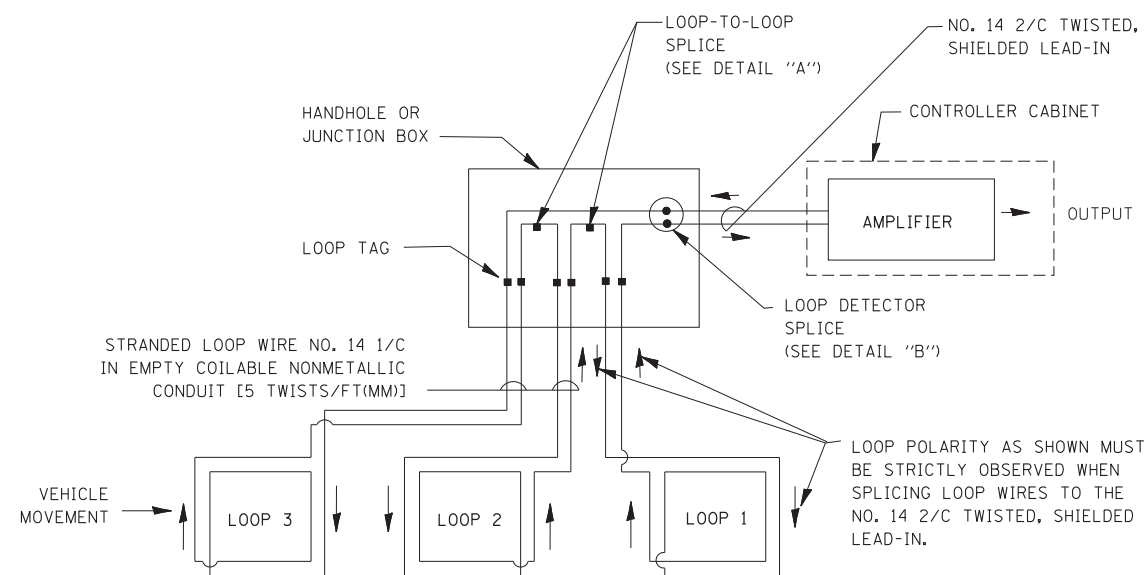

DETECTOR LOOP WIRING SCHEMATIC

- LOOPS SHALL BE SPLICED IN SERIES.
- SAW-CUTS SHALL BE A MINIMUM WIDTH OF 5/16" (8 mm).
- SAW-CUT DEPTHS SHALL BE 3" (75 mm). IF IN CONCRETE, THE SAW-CUT DEPTH SHALL BE TO THE TOP OF THE REINFORCEMENT.
- LOOP CORNERS SHALL BE DRILLED WITH A 2" (50 mm) DIAMETER CORE.

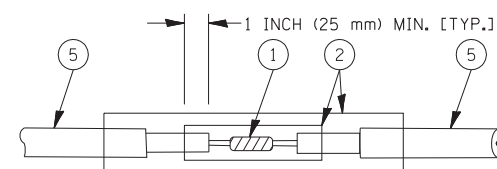

DETAIL "A"
LOOP-TO-LOOP SPLICE

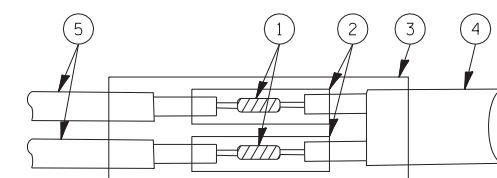

DETAIL "B"
LOOP-TO-CONTROLLER SPLICE

TYPE I LOOP

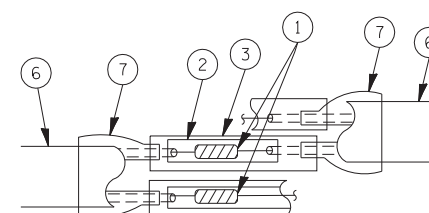

DETAIL "A"
LOOP-TO-LOOP SPLICE

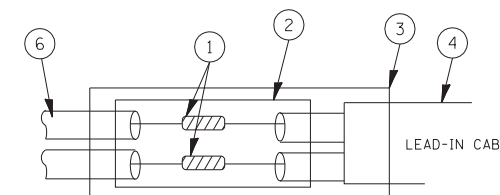

DETAIL "B"
LOOP-TO-CONTROLLER SPLICE

LOOP DETECTOR SPLICE

- WESTERN UNION SPLICE SOLDERED WITH ROSIN CORE FLUX. ALL EXPOSED SURFACES OF THE SOLDER SHALL BE SMOOTH.
- WCSMW 30/100 HEAT SHRINK TUBE, MINIMUM LENGTH 3" (75 mm), UNDERWATER GRADE.
- WCS 200/750 HEAT SHRINK TUBE, MINIMUM LENGTH 6" (150 mm), UNDERWATER GRADE.
- NO. 14 2/C TWISTED, SHIELDED CABLE.
- LOOP CONDUCTOR WITH FLEXIBLE PLASTIC TUBE.
- PREFORMED LOOP
- XL POLYOLEFIN 2 CONDUCTOR BREAKOUT SEALS. TYCO CBR-2 OR APPROVED EQUAL

FILE NAME =	USER NAME = bauerdl	DESIGNED - DAD	REVISED -
ct:\pw\work\PWIDOT\BAUERDL\d0108315\ts05.dgn		DRAWN - BCK	REVISED -
	PLOT SCALE = 50.0000' / IN.	CHECKED - DAD	REVISED -
	PLOT DATE = 11/4/2009	DATE - 10-28-09	REVISED -

STATE OF ILLINOIS
DEPARTMENT OF TRANSPORTATION

DISTRICT ONE
STANDARD TRAFFIC SIGNAL DESIGN DETAILS

SCALE: NONE SHEET NO. 1 OF 6 SHEETS STA. TO STA.

F.A. RTE.	SECTION	COUNTY	TOTAL SHEETS	SHEET NO.
94	49-1-R-1	LAKE	677	333
FED. ROAD DIST. NO. 1 ILLINOIS FED. AID PROJECT			CONTRACT NO. 60L77	

TS-02

TRAFFIC SIGNAL MAST ARM AND SIGNAL POST

MAST ARM MOUNTED SIGNALS IN EXISTING, PROPOSED OR FUTURE SIDEWALK/BICYCLE PATH AREA. INTERSECTION SHOWN WITH PEDESTRIAN SIGNALS AND PEDESTRIAN PUSHBUTTON DETECTORS.

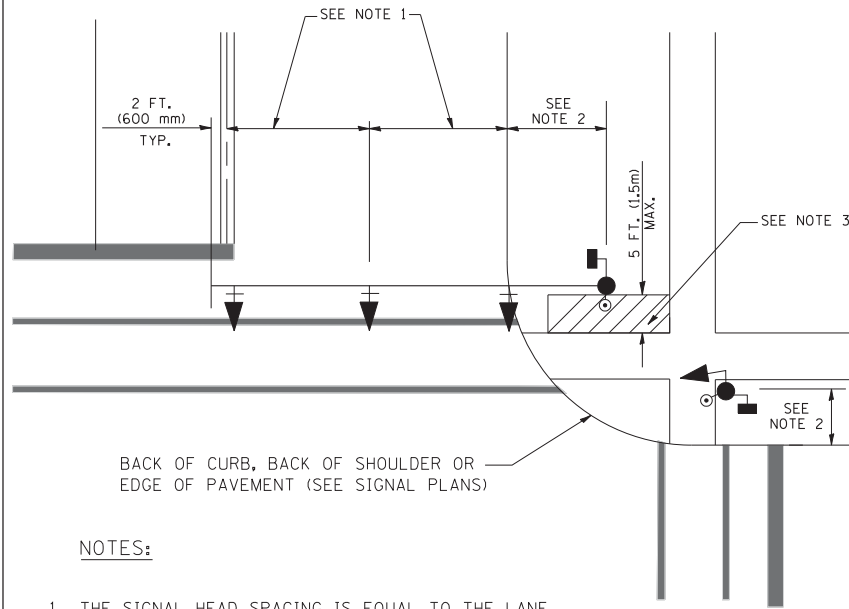

NOTES:

1. THE SIGNAL HEAD SPACING IS EQUAL TO THE LANE WIDTH OR AS SHOWN ON THE TRAFFIC SIGNAL PLAN.
2. REFER TO THE TRAFFIC SIGNAL EQUIPMENT OFFSET TABLE.
3. PROVIDE A LEVEL ALL-WEATHER SURFACE (CONCRETE SIDEWALK, ASPHALT BICYCLE PATH SURFACE OR MATCHING MATERIAL TO THE ADJACENT SURFACE) UP TO THE MAST ARM SHAFT OR THE SIGNAL POST.
4. THE FACE OF THE PEDESTRIAN PUSHBUTTON SHALL BE PARALLEL TO THE CROSSWALK TO BE USED.
5. THE LOCATIONS AND INSTALLATION OF PEDESTRIAN SIGNAL HEADS AND PEDESTRIAN PUSHBUTTONS SHALL MEET THE REQUIREMENTS OF THE MUTCD AND INFORMATION FOUND IN THE "AMERICANS WITH DISABILITIES ACT ACCESSIBILITY GUIDELINES FOR BUILDINGS AND FACILITIES."

PEDESTRIAN SIGNAL POST AND PEDESTRIAN PUSH BUTTON POST

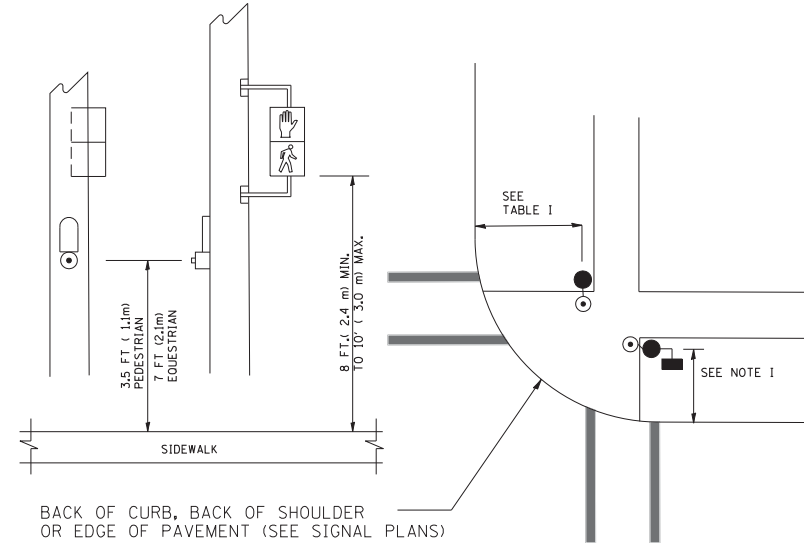

NOTES:

1. REFER TO THE TRAFFIC SIGNAL EQUIPMENT OFFSET TABLE.
2. PROVIDE A LEVEL ALL-WEATHER SURFACE (CONCRETE SIDEWALK, ASPHALT BICYCLE PATH SURFACE OR MATCHING MATERIAL TO THE ADJACENT SURFACE) UP TO THE PEDESTRIAN SIGNAL POST OR THE PEDESTRIAN PUSH BUTTON POST.
3. THE FACE OF THE PEDESTRIAN PUSHBUTTON SHALL BE PARALLEL TO THE CROSSWALK TO BE USED.
4. THE LOCATIONS AND INSTALLATION OF PEDESTRIAN SIGNAL HEADS AND PEDESTRIAN PUSHBUTTONS SHALL MEET THE REQUIREMENTS OF THE MUTCD AND INFORMATION FOUND IN THE "AMERICANS WITH DISABILITIES ACT ACCESSIBILITY GUIDELINES FOR BUILDINGS AND FACILITIES."

RECOMMENDED PUSHBUTTON LOCATIONS

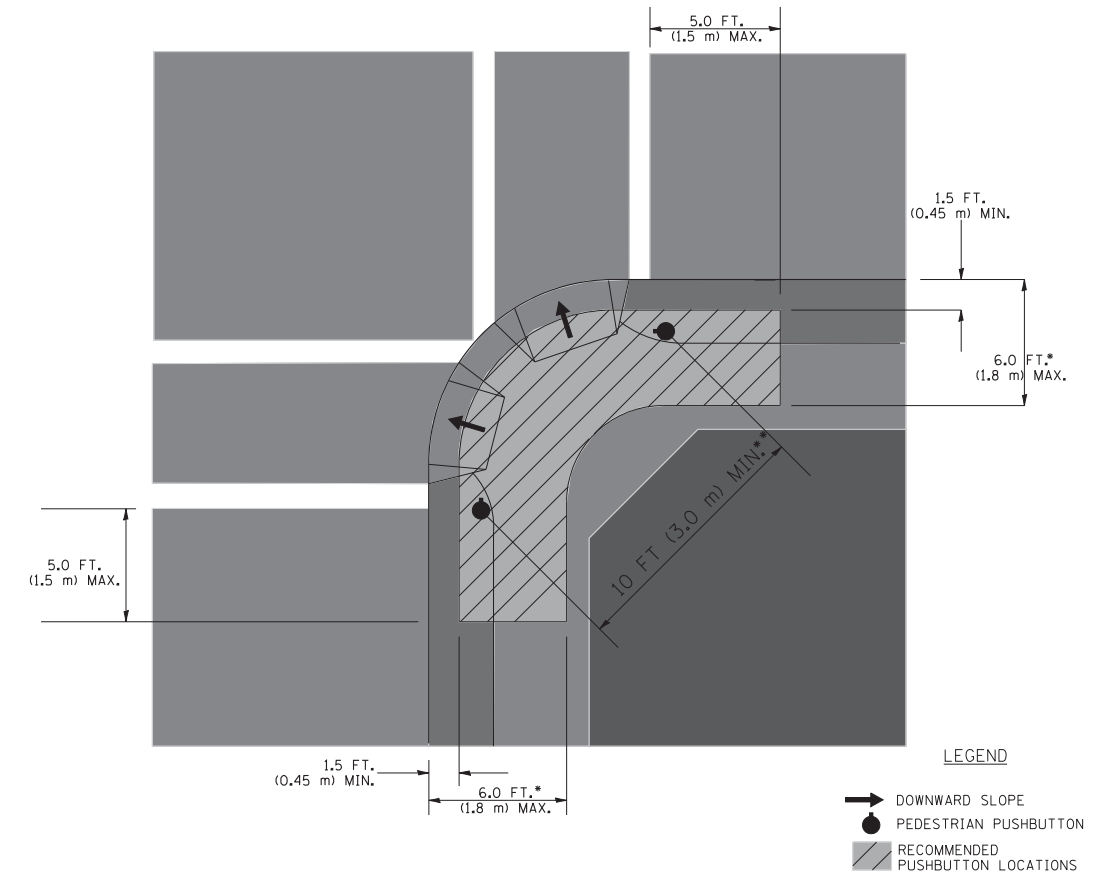

- WHERE THERE ARE CONSTRAINTS THAT MAKE IT IMPRACTICAL TO PLACE THE PEDESTRIAN PUSHBUTTON BETWEEN 1.5 FT (0.45 m) AND 6 FT (1.8 m) FROM THE EDGE OF THE CURB, SHOULDER, OR PAVEMENT, IT SHOULD NOT BE FURTHER THAN 10 FT (3 m) FROM THE EDGE OF CURB, SHOULDER, OR PAVEMENT.
- WHERE THERE ARE CONSTRAINTS ON A PARTICULAR CORNER THAT MAKE IT IMPRACTICAL TO PROVIDE THE 10 FT (3 m) SEPERATION BETWEEN THE TWO PEDESTRIAN PUSHBUTTONS, THE PUSHBUTTONS MAY BE PLACED CLOSER TOGETHER OR ON THE SAME POLE.

NOTES:

1. PEDESTRIAN SIGNAL HEADS SHALL BE MOUNTED WITH THE BOTTOM OF THE SIGNAL HOUSING INCLUDING BRACKETS NOT LESS THAN 8 FT (2.4 m) OR MORE THAN 10 FT (3 m) ABOVE SIDEWALK LEVEL, AND SHALL BE POSITIONED AND ADJUSTED TO PROVIDE MAXIMUM VISIBILITY AT THE BEGINNING OF THE CONTROLLED CROSSWALK.
2. THE BOTTOM OF THE SIGNAL HOUSING (INCLUDING BRACKETS) OF A VEHICULAR SIGNAL FACE THAT IS NOT LOCATED OVER A HIGHWAY SHALL BE AT LEAST 8 FT (2.4 m) BUT NOT MORE THAN 19 FT (5.8 m) ABOVE THE SIDEWALK OR, IF THERE IS NO SIDEWALK, ABOVE THE PAVEMENT GRADE AT THE CENTER OF THE ROADWAY.
3. THE BOTTOM OF THE SIGNAL HOUSING AND ANY RELATED ATTACHMENTS TO A SIGNAL FACE LOCATED OVER ANY PORTION OF A HIGHWAY SHALL BE ACCORDING TO CURRENT STATE STANDARDS 877001, 877002, 877006, 877011 AND 877012 WITH A MINIMUM OF 16 FT (5.0 m) AND A MAXIMUM OF 18 FT. (5.5 m) FROM THE HIGHEST POINT OF PAVEMENT.
4. THE BOTTOM OF THE TEMPORARY SPAN WIRE MOUNTED SIGNAL HOUSING AND ANY RELATED ATTACHMENTS TO A SIGNAL FACE LOCATED OVER ANY PORTION OF A HIGHWAY SHALL BE ACCORDING TO CURRENT STATE STANDARD 880001 WITH A MINIMUM OF 17 FT (5.18 m) FROM THE HIGHEST POINT OF PAVEMENT.
5. THE TOP OF THE SIGNAL HOUSING OF A SIGNAL FACE LOCATED OVER ANY PORTION OF A HIGHWAY SHALL NOT BE MORE THAN 25.6 FT (7.8 m) ABOVE THE PAVEMENT.

TRAFFIC SIGNAL EQUIPMENT OFFSET

TRAFFIC SIGNAL EQUIPMENT	COMBINATION CONCRETE CURB AND GUTTER (MINIMUM DISTANCE FROM BACK OF CURB TO CENTERLINE OF FOUNDATION)	SHOULDER/NON-CURBED AREA (MINIMUM DISTANCE FROM EDGE OF PAVEMENT TO CENTERLINE OF FOUNDATION)
TRAFFIC SIGNAL MAST ARM POLE	6 FT (1.8m)	SHOULDER WIDTH + 2 FT (0.6m), MINIMUM 10 FT (3.0m)
TRAFFIC SIGNAL POST	4 FT (1.2m)	SHOULDER WIDTH + 2 FT (0.6m), MINIMUM 10 FT (3.0m)
PEDESTRIAN SIGNAL POST	4 FT (1.2m)	SHOULDER WIDTH + 2 FT (0.6m), MINIMUM 10 FT (3.0m)
PEDESTRIAN PUSHBUTTON POST	4 FT (1.2m)	SHOULDER WIDTH + 2 FT (0.6m), MINIMUM 10 FT (3.0m)
TEMPORARY WOOD POLE	6 FT (1.8m)	SHOULDER WIDTH + 2 FT (0.6m), MINIMUM 10 FT (3.0m)
CONTROLLER CABINET	6 FT (1.8m) MINIMUM DISTANCE SEE NOTE 2	SHOULDER WIDTH + 6 FT (1.8m), MINIMUM 16 FT (4.9m) SEE NOTE 3.
SERVICE INSTALLATION, GROUND MOUNT	6 FT (1.8m) MINIMUM DISTANCE SEE NOTE 2	SHOULDER WIDTH + 6 FT (1.8m), MINIMUM 16 FT (4.9m) SEE NOTE 3.

NOTES:

1. CONTACT THE "AREA TRAFFIC SIGNAL MAINTENANCE AND OPERATIONS ENGINEER" FOR ASSISTANCE IN LOCATING THE TRAFFIC SIGNAL EQUIPMENT WHEN THERE ARE CONFLICTS WITH DITCHES OR THE MINIMUM OFFSET DISTANCES CANNOT BE MET.
2. MINIMUM DISTANCE FROM THE BACK OF CURB TO THE ROADWAY SIDE OF THE FOUNDATION.
3. MINIMUM DISTANCE FROM THE EDGE OF PAVEMENT TO THE ROADWAY SIDE OF THE FOUNDATION.
4. ANY CHANGES TO THE OFFSETS OF THE FOUNDATIONS, FROM THE MINIMUM DISTANCES LISTED IN THE "TRAFFIC SIGNAL EQUIPMENT OFFSET" CHART AND THE TRAFFIC SIGNAL INSTALLATION PLAN, COULD EFFECT THE PLACEMENT OF THE SIGNAL HEADS, PEDESTRIAN SIGNAL HEADS AND THE PEDESTRIAN PUSHBUTTONS. THE SIGNAL HEAD PLACEMENT ON THE MAST ARMS SHALL REMAIN AS PER THE TRAFFIC SIGNAL INSTALLATION PLAN AND THE "TRAFFIC SIGNAL MAST ARM AND SIGNAL POST" DETAIL ABOVE. THE PROPOSED MAST ARM LENGTHS MAY NEED TO BE REVISED TO MEET THE ABOVE REQUIREMENTS. THE PEDESTRIAN SIGNAL HEADS AND PEDESTRIAN PUSHBUTTONS MUST MEET THE REQUIREMENTS UNDER THE DETAILS ON THIS SHEET.

TS-03

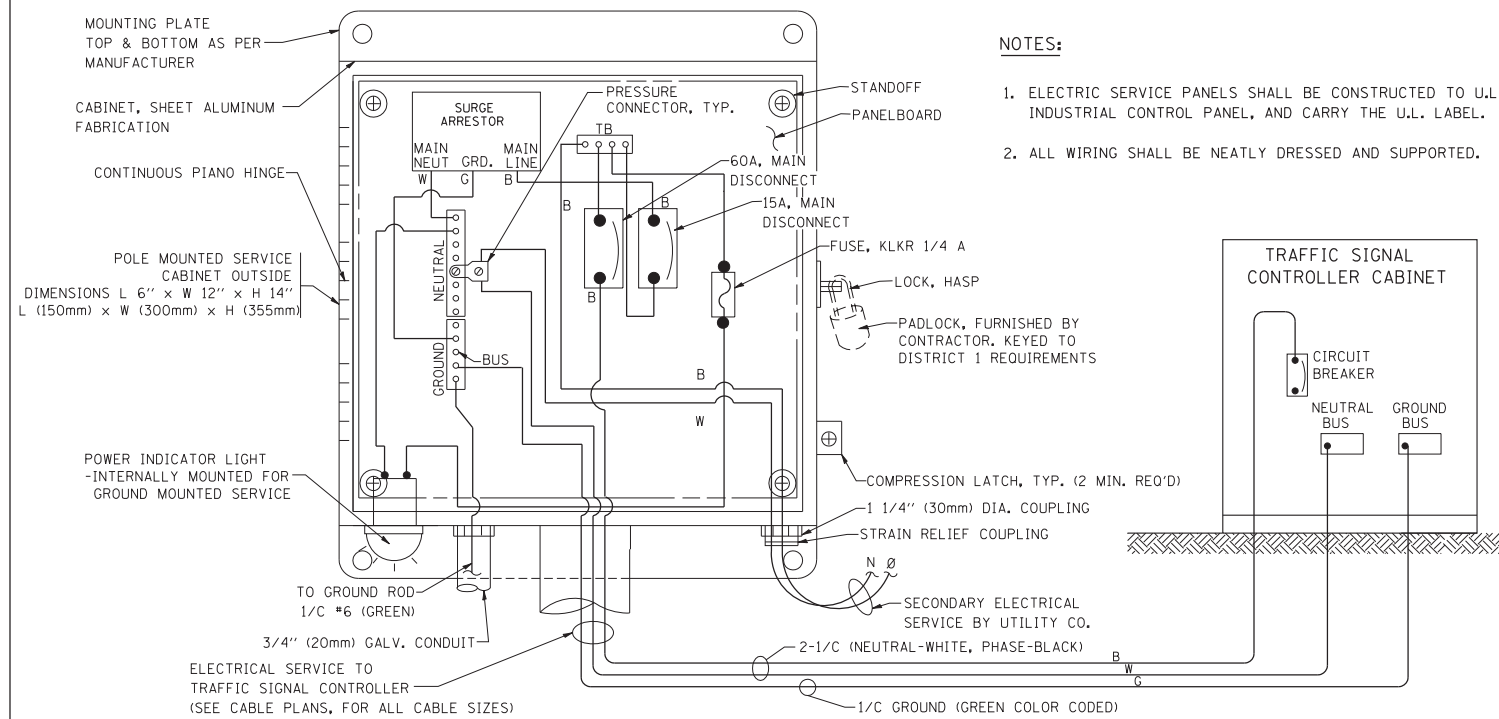

NOTES:

1. ELECTRIC SERVICE PANELS SHALL BE CONSTRUCTED TO U.L. STD 508, INDUSTRIAL CONTROL PANEL, AND CARRY THE U.L. LABEL.
2. ALL WIRING SHALL BE NEATLY DRESSED AND SUPPORTED.

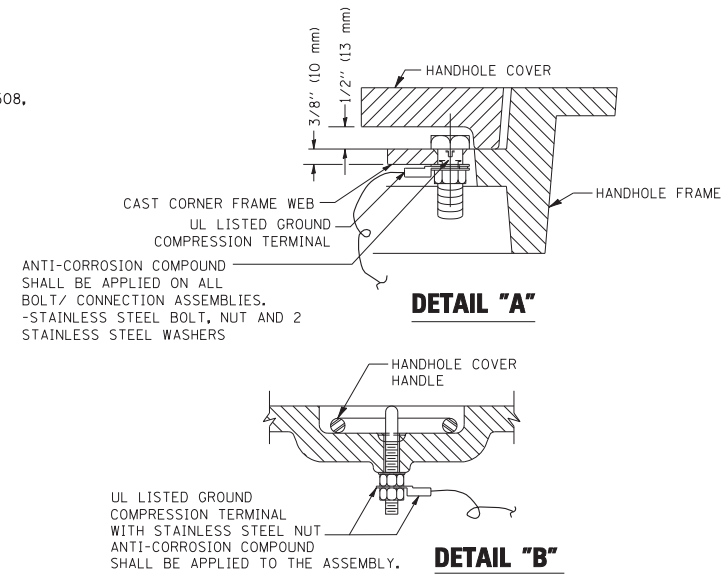

NOTES:

GROUNDING SYSTEM

1. THE GROUNDING SYSTEM SHALL CONSIST OF AN INSULATED CONDUCTOR TYPE XLP, NO. 6 A.W.G., STRANDED COPPER TO BE INSTALLED IN RACEWAYS. THE GROUNDING CABLE SHALL BE INSTALLED IN A CONTINUOUS MANNER AS SHOWN ON THE CABLE PLAN PROVIDED. ALL GROUNDING CONDUCTORS SHALL BE BONDED TO METAL ENCLOSURE (HANDHOLE, POST, MAST ARM, CONTROLLER, ETC.). GROUND ROD SHALL BE 3/4" DIA. x 10'-0" (20mm x 3.0m) LONG, COPPER CLAD. ONE GROUND ROD SHALL BE INSTALLED AT ALL POST FOUNDATIONS, POLE FOUNDATIONS, CONTROLLER CABINET FOUNDATION AND ELECTRICAL SERVICE INSTALLATION AS INDICATED ON THE CABLE PLAN. IF THERE ARE ANY SPECIAL CONDITIONS SUCH AS SUB-SURFACE CONDITIONS OR INSTALLATION PROBLEMS, THE RESIDENT ENGINEER SHALL BE NOTIFIED OR CONTACT THE BUREAU OF TRAFFIC, ILLINOIS DEPARTMENT OF TRANSPORTATION DISTRICT ONE AT (847) 705-4139.
2. THE NEUTRAL CONDUCTOR AND THE GROUND CONDUCTOR SHALL BE CONNECTED IN THE SERVICE INSTALLATION. AT NO OTHER POINT IN THE TRAFFIC SIGNAL SYSTEM SHALL THE NEUTRAL AND GROUND CONDUCTORS BE CONNECTED.
3. ALL EQUIPMENT GROUNDING CONDUCTORS SHALL TERMINATE AT THE GROUND BUS IN THE CONTROLLER CABINET.
4. THE CONTRACTOR SHALL PROVIDE A GROUND CABLE WITH CONNECTORS BETWEEN THE HANDHOLE COVER AND HANDHOLE FRAME.

ELECTRICAL SERVICE - PANEL DIAGRAM (TYPICAL FOR POLE AND GROUND MOUNTED SERVICE)

SERVICE INSTALLATION POLE MOUNT (SHOWN)
(NOT TO SCALE)

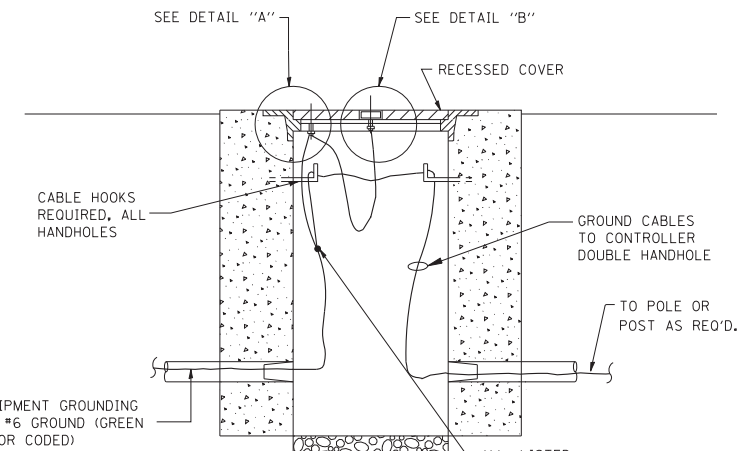

HANDHOLE COVER & FRAME - GROUNDING DETAIL

(NOT TO SCALE)

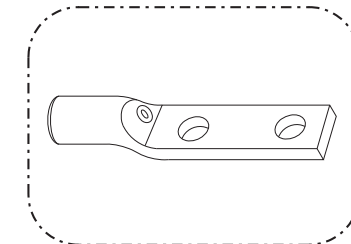

HEAVY-DUTY COMPRESSION TERMINAL (BURNDY TYPE YGHA OR APPROVED EQUAL)

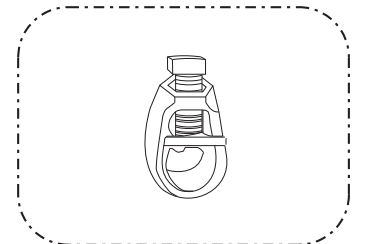

3/4" (20mm) HEAVY-DUTY GROUND ROD CLAMP (BURNDY TYPE GRC OR APPROVED EQUAL)

NOTES:

- ALL CLAMPS SHALL BE BRONZE OR COPPER, UL APPROVED.
- GROUND CABLE SHALL BE LOOPED OVER HOOKS IN THE HANDHOLES 6.5' (2.0m) SLACK SHALL BE PROVIDED IN SINGLE HANDHOLES 13' (4.0m) OF SLACK SHALL BE PROVIDED IN DOUBLE HANDHOLES. 5' (1.4m) OF SLACK SHALL BE PROVIDED BETWEEN FRAME AND COVER.

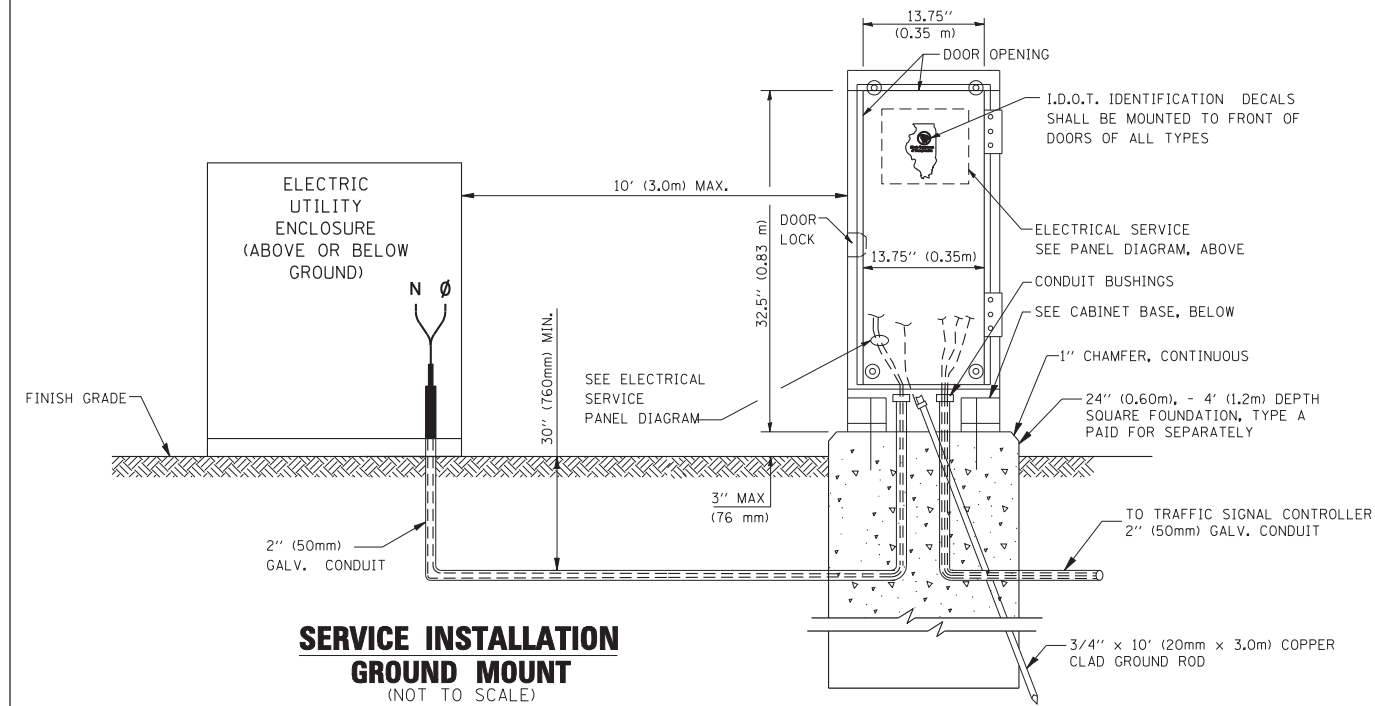

SERVICE INSTALLATION GROUND MOUNT
(NOT TO SCALE)

CABINET - BASE BOLT PATTERN
(NOT TO SCALE)

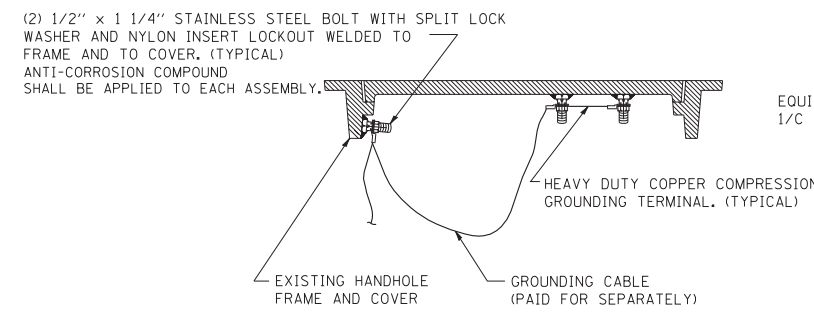
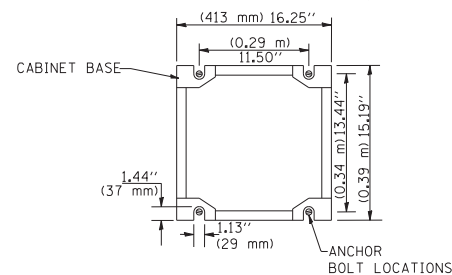

EXISTING HANDHOLE COVER & FRAME - GROUNDING DETAIL

(NOT TO SCALE)

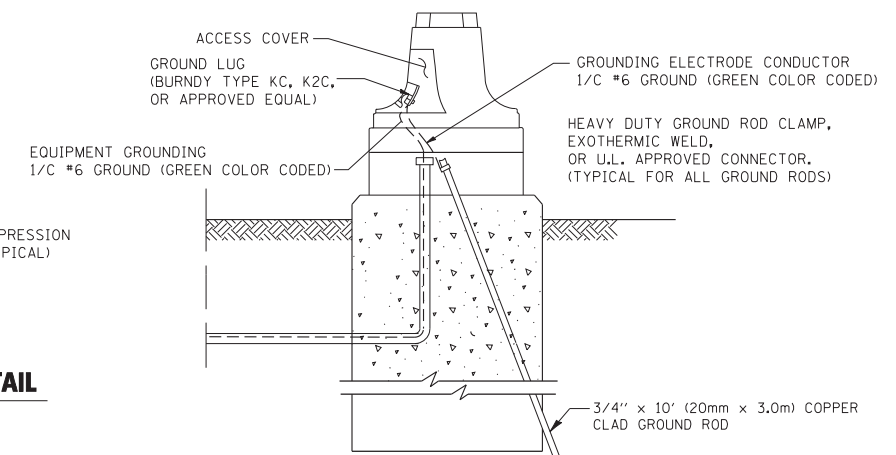

MAST ARM POLE / POST-GROUNDING DETAIL

(NOT TO SCALE)

FILE NAME =	USER NAME = kanthapixaybc	DESIGNED - DAD	REVISED -
cs:\pw\work\PWIDOT\KANTHAPHIXAYBC\d011264\tr of fic.legend.v7.dgn		DRAWN - BCK	REVISED -
		CHECKED - DAD	REVISED -
		DATE - 10/28/09	REVISED -

**STATE OF ILLINOIS
DEPARTMENT OF TRANSPORTATION**

DISTRICT 1
STANDARD TRAFFIC SIGNAL DESIGN DETAILS

SCALE: SHEET NO. OF SHEETS STA. TO STA.

F.A. RTE.	SECTION	COUNTY	TOTAL SHEETS	SHEET NO.
94	49-1-R-1	LAKE	677	335
FED. ROAD DIST. NO. ILLINOIS FED. AID PROJECT			CONTRACT NO. 60L77	

TS-04

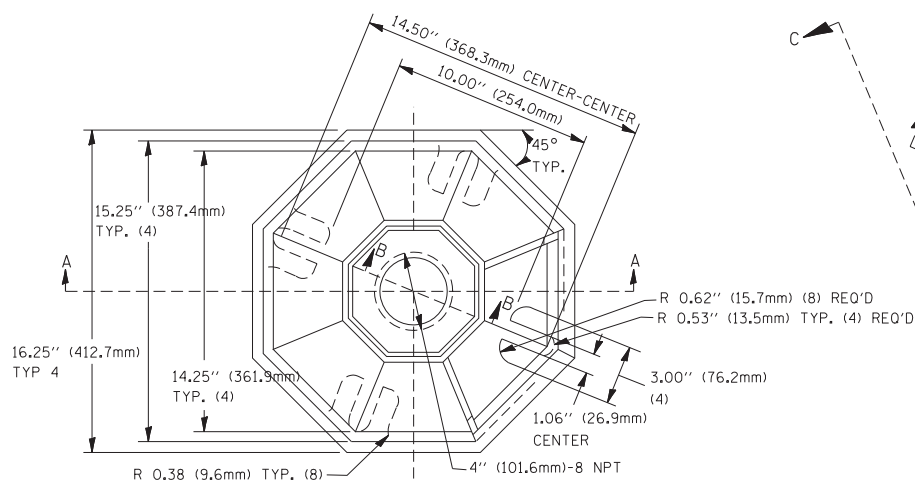

TOP VIEW

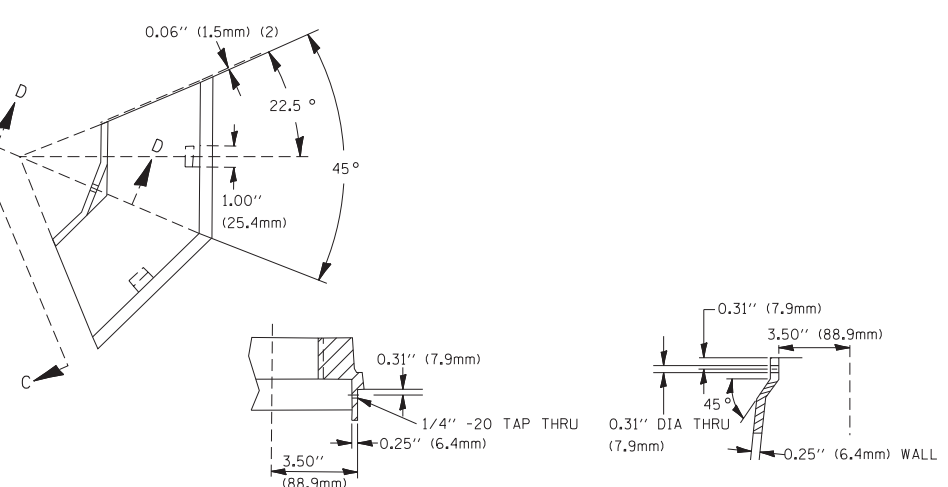

SECTION B-B

SECTION D-D

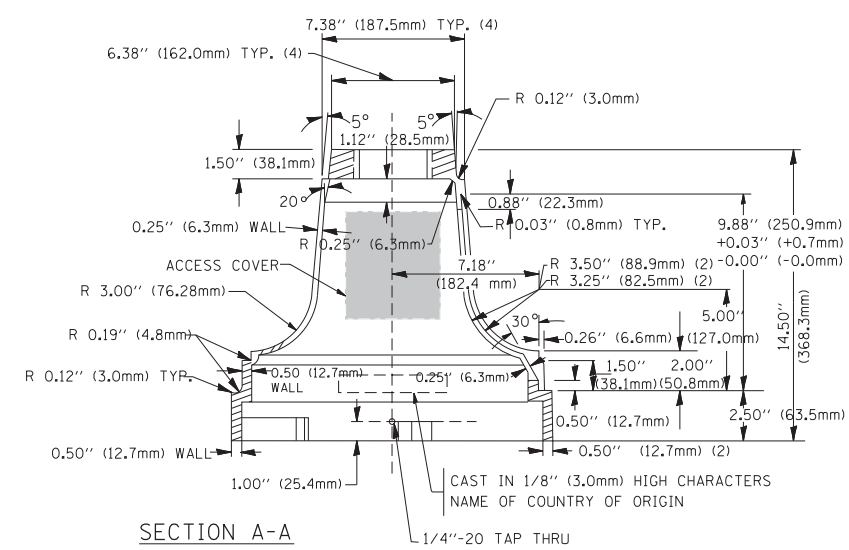

SECTION A-A

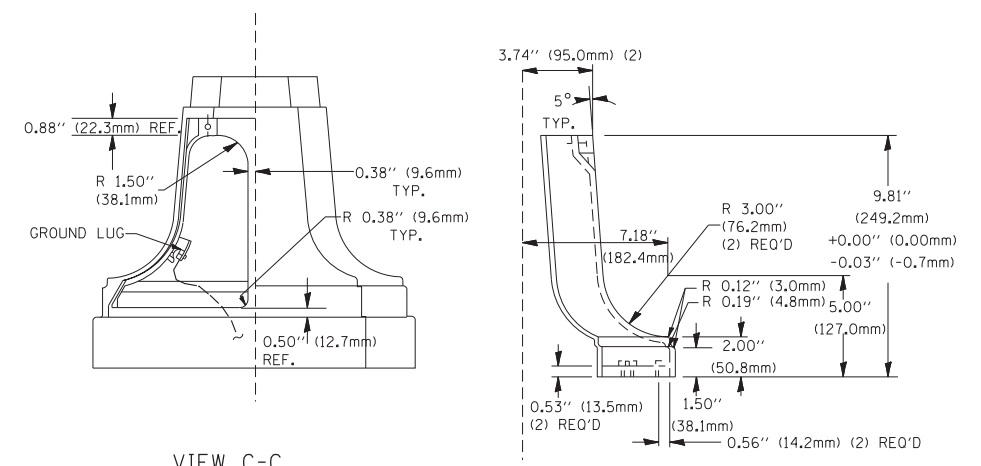

VIEW C-C

TRAFFIC SIGNAL POST - MOUNTING BASE - TYPE A

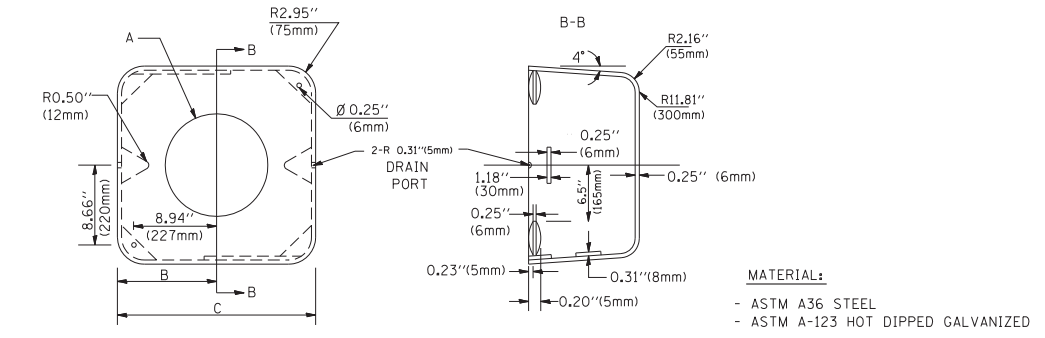

SHROUD

A	B	C	HEIGHT	WEIGHT
VARIES	9.5\"(241mm)	19\"(483mm)	7\"(178mm) - 12\"(300mm)	53 lbs (24kg)
VARIES	10.75\"(273mm)	21.5\"(546mm)	7\"(178mm) - 12\"(300mm)	68 lbs (31 kg)
VARIES	13.0\"(330mm)	26\"(660mm)	7\"(178mm) - 12\"(300mm)	81 lbs (37 kg)
VARIES	18.5\"(470mm)	37\"(940mm)	7\"(178mm) - 12\"(300mm)	126 lbs (57 kg)

NOTES:

- DIMENSION "A" IS EQUAL TO THE DIAMETER OF THE MAST ARM POLE AT THE TOP OF THE SHROUD. THE SHROUD SHALL BE TIGHT TO THE MAST ARM POLE.
- THE SUPPLIER SHALL VERIFIED THE ABOVE DIMENSIONS BASED ON MAST ARM REQUIREMENTS.
- THE HEIGHT OF THE SHROUD SHALL COVER THE ANCHOR BOLTS, NUTS AND MAST ARM POLE BASE.

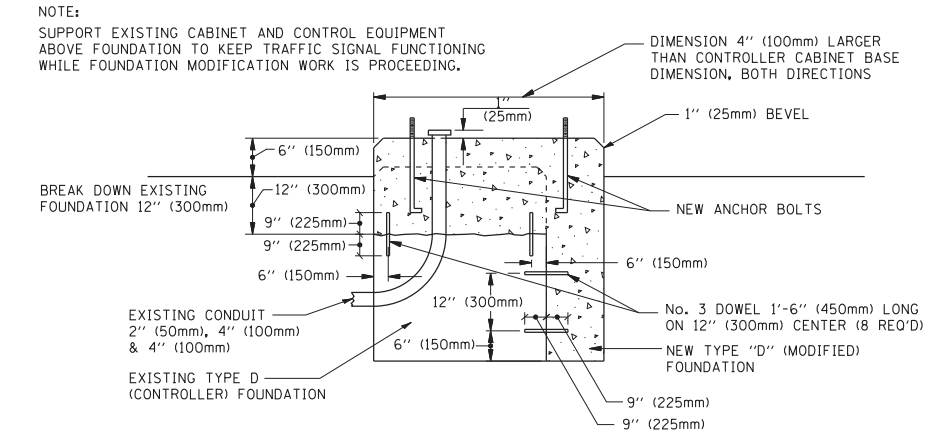

MODIFY EXISTING TYPE "D" FOUNDATION

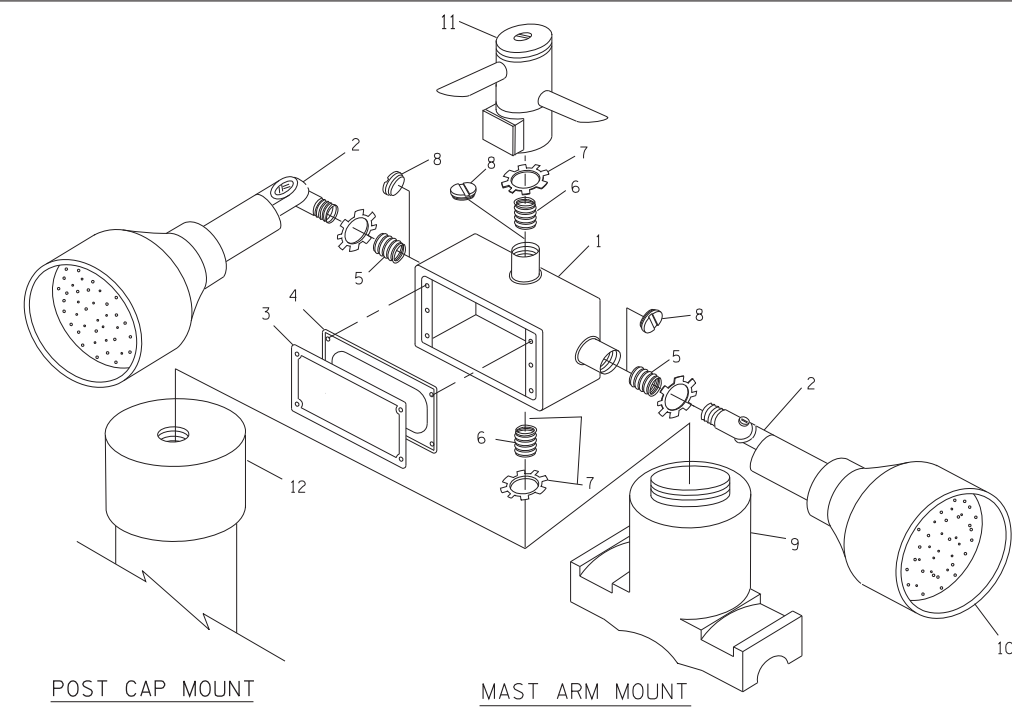

POST CAP MOUNT

MAST ARM MOUNT

EMERGENCY VEHICLE DETECTOR WITH CONFIRMATION BEACON MOUNTING DETAIL

ITEM NO.	IDENTIFICATION
1	OUTLET BOX- GALV. 21 CU.IN. (0.000344 CU-M)
2	LAMP HOLDER AND COVER
3	OUTLET BOX COVER
4	RUBBER COVER GASKET
5	REDUCING BUSHING
6	3/4\"(19 mm) CLOSE NIPPLE
7	3/4\"(19 mm) LOCKNUT
8	3/4\"(19 mm) HOLE PLUG
9	SADDLE BRACKET - GALV.
10	6 WATT PAR 38 LED FLOOD LAMP
11	DETECTOR UNIT
12	POST CAP [18 FT. (5.4 m) POST MIN.]

NOTES:

- ALL ELECTRICAL ITEMS, EXCEPT ITEMS #2 AND #11 SHALL BE ALUMINUM OR GALVANIZED
- ITEM #1- OZ/GEDNEY FSX-1-50 OR EQUIVALENT
ITEM #2- MULBERRY CON-0-SHADE LAMP SHIELD OR EQUIVALENT
ITEM #9- "BAND-IT" SADDLE BRACKET OR EQUIVALENT
- WHEN POST MOUNTING IS SPECIFIED, ITEM #9 SHALL NOT BE REQUIRED. THE DETECTION UNIT SHALL BE MOUNTED DIRECTLY ON TOP OF THE CAP BY DRILLING AND TAPPING A 3/4\"(19 mm) HOLE WITH PIPE THREADS. THE POST CAP SHALL EITHER BE SCREWED TO THE TOP OF THE POST OR A MINIMUM OF 3 TIGHTENING SCREWS SHALL BE REQUIRED ON EACH CAP.

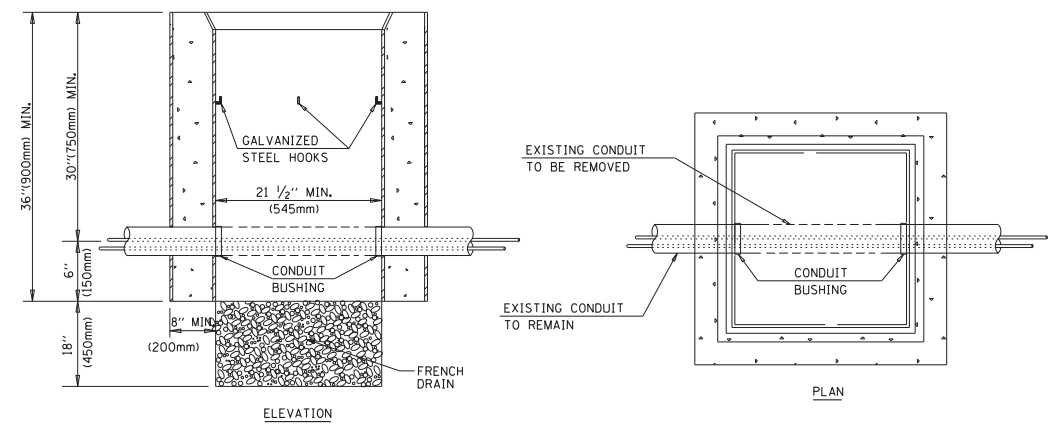

HANDHOLE TO INTERCEPT EXISTING CONDUIT

NOTES:

- HANDHOLE CONSTRUCTED PER STATE STANDARD 814001.
- REMOVAL OF THE EXISTING CONDUIT FROM THE HANDHOLE AND THE INSTALLATION OF THE CONDUIT BUSHINGS SHALL BE INCIDENTAL TO THE HANDHOLE.

FILE NAME =	USER NAME = bauerdl	DESIGNED - DAD	REVISED -
ca:\pwork\p\WIDOT\BAUERDL\d0108315\ts05.dgn		DRAWN - BCK	REVISED -
		CHECKED - DAD	REVISED -
		DATE - 10-28-09	REVISED -

STATE OF ILLINOIS
DEPARTMENT OF TRANSPORTATION

DISTRICT ONE
STANDARD TRAFFIC SIGNAL DESIGN DETAILS

SCALE: NONE SHEET NO. 4 OF 6 SHEETS STA. TO STA.

F.A. RTE.	SECTION	COUNTY	TOTAL SHEETS	SHEET NO.
94	49-1-R-1	LAKE	677	336
CONTRACT NO. 60L77				
FED. ROAD DIST. NO. 1 ILLINOIS FED. AID PROJECT				

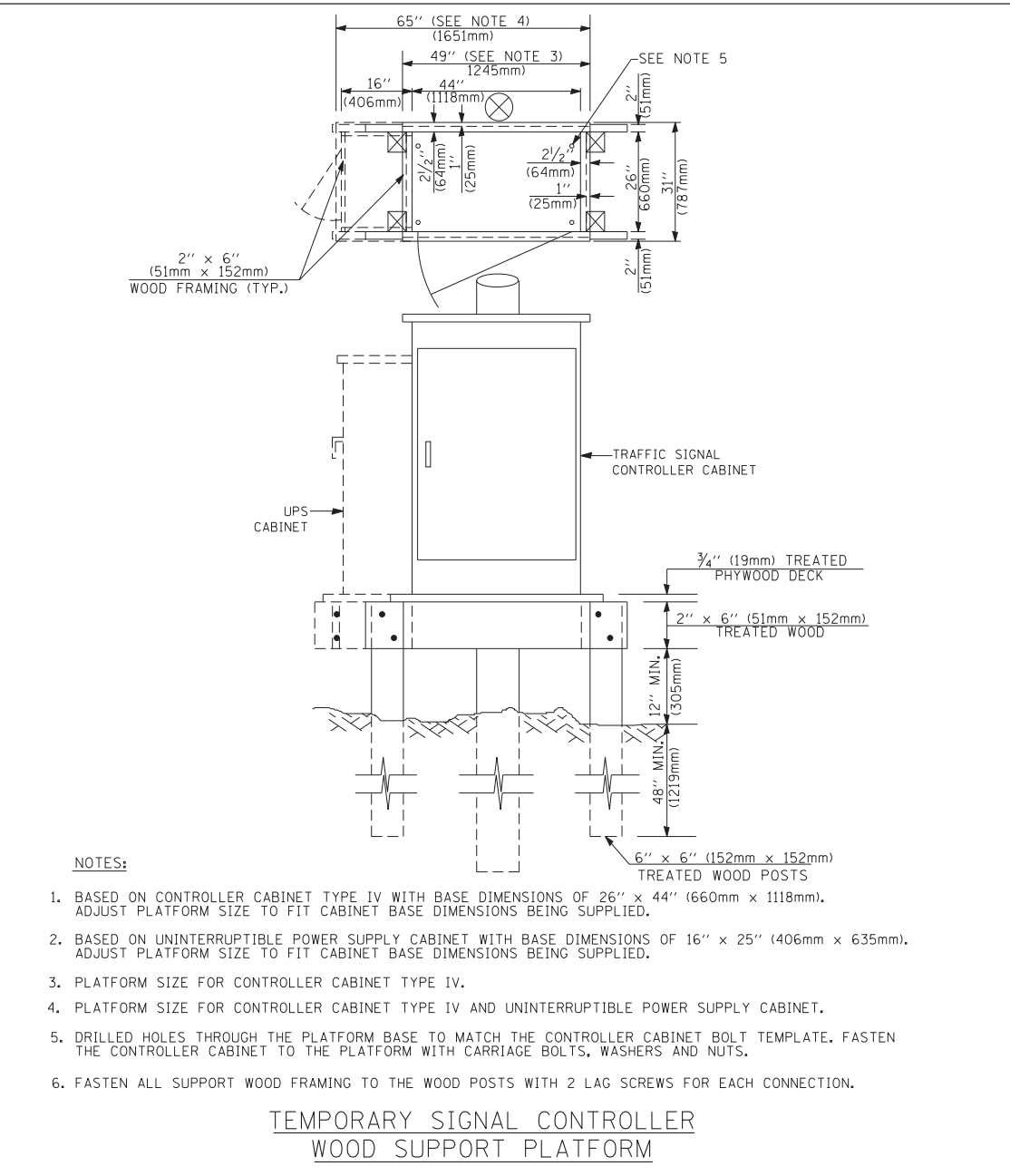
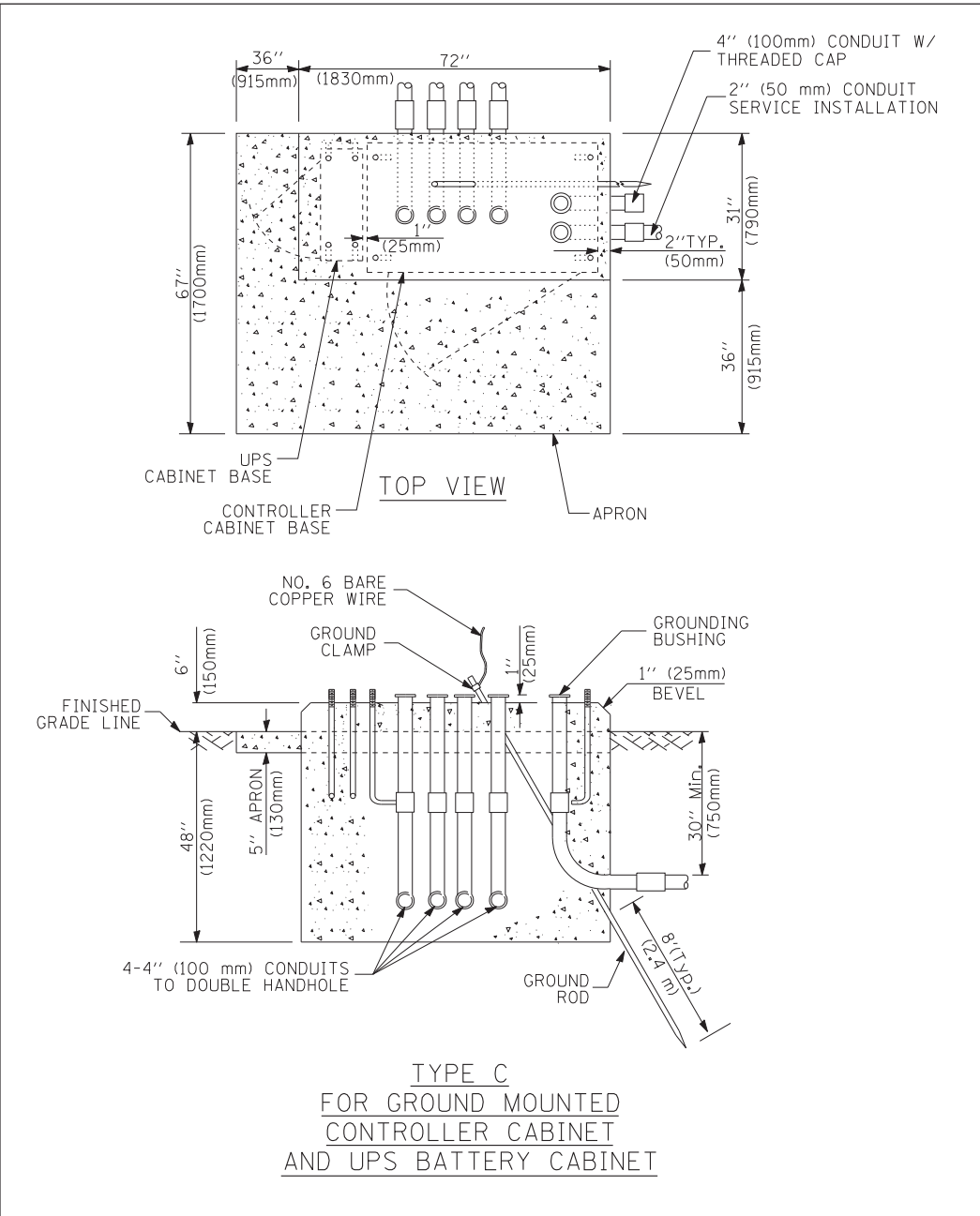
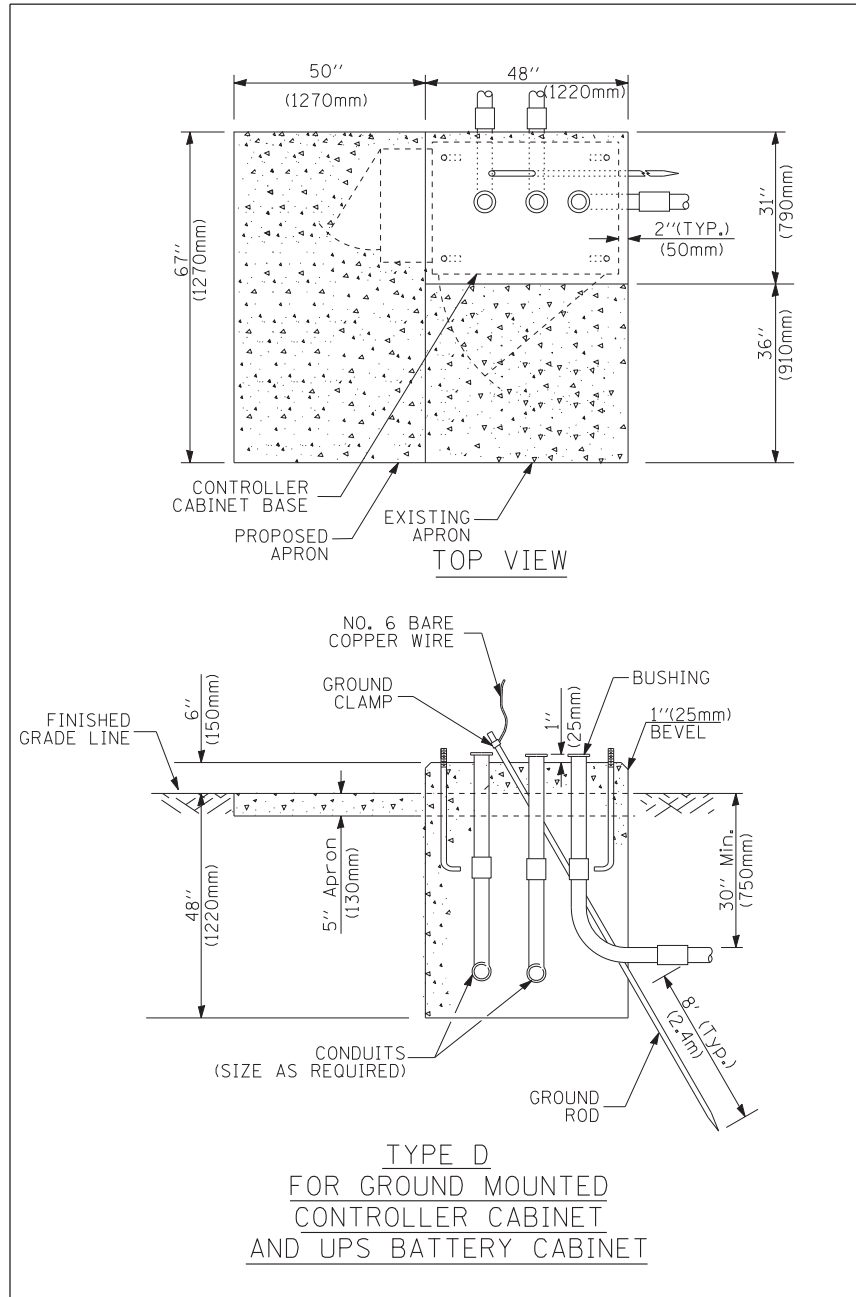

- NOTES:**
- BASED ON CONTROLLER CABINET TYPE IV WITH BASE DIMENSIONS OF 26" x 44" (660mm x 1118mm). ADJUST PLATFORM SIZE TO FIT CABINET BASE DIMENSIONS BEING SUPPLIED.
 - BASED ON UNINTERRUPTIBLE POWER SUPPLY CABINET WITH BASE DIMENSIONS OF 16" x 25" (406mm x 635mm). ADJUST PLATFORM SIZE TO FIT CABINET BASE DIMENSIONS BEING SUPPLIED.
 - PLATFORM SIZE FOR CONTROLLER CABINET TYPE IV.
 - PLATFORM SIZE FOR CONTROLLER CABINET TYPE IV AND UNINTERRUPTIBLE POWER SUPPLY CABINET.
 - DRILLED HOLES THROUGH THE PLATFORM BASE TO MATCH THE CONTROLLER CABINET BOLT TEMPLATE. FASTEN THE CONTROLLER CABINET TO THE PLATFORM WITH CARRIAGE BOLTS, WASHERS AND NUTS.
 - FASTEN ALL SUPPORT WOOD FRAMING TO THE WOOD POSTS WITH 2 LAG SCREWS FOR EACH CONNECTION.

CABLE SLACK LENGTH	FEET	METER
HANDHOLE	6.5	2.0
DOUBLE HANDHOLE	13.0	4.0
SIGNAL POST	2.0	0.6
MAST ARM	2.0	0.6
CONTROLLER CABINET	1.5	0.5
FIBER OPTIC AT CABINET	13.0	4.0
ELECTRIC SERVICE AT (CABINET OR SERVICE LOCATION)	1.5	0.5
GROUND CABLE (SIGNAL POST, MAST ARM, CABINET)	1.5	0.5
GROUND CABLE (BETWEEN FRAME AND COVER)	5.0	1.6

CABLE SLACK

VERTICAL CABLE LENGTH	FEET	METER
MAST ARM POLE (MAST ARM MOUNTED SIGNAL HEAD) (L = MAST ARM LENGTH - DISTANCE TO SIGNAL HEAD FROM END OF ARM)	20.0+L	6.0+L
BRACKET MOUNTED (MAST ARM POLE OR SIGNAL POLE)	13.0	4.0
PEDESTRIAN PUSH BUTTON	6.0	2.0
SERVICE INSTALLATION POLE MOUNT TO SERVICE DROP	13.5	4.1
SERVICE INSTALLATION POLE MOUNT TO GROUND	13.5	4.1
SERVICE INSTALLATION GROUND MOUNT	6.0	2.0
FOUNDATION (SIGNAL POST, MAST ARM POLE, CONTROLLER CABINET, SERVICE-GROUND MOUNT)	3.0	1.0

VERTICAL CABLE LENGTH

FOUNDATION	DEPTH
TYPE A - Signal Post	4'-0" (1.2m)
TYPE C - CONTROLLER W/ UPS	4'-0" (1.2m)
TYPE D - CONTROLLER	4'-0" (1.2m)
SERVICE INSTALLATION, GROUND MOUNT, TYPE A - SQUARE	4'-0" (1.2m)

DEPTH OF FOUNDATION

MAST ARM LENGTH	FOUNDATION DEPTH	FOUNDATION DIAMETER	SPIRAL DIAMETER	QUANTITY OF REBARS	SIZE OF REBARS
Less than 30' (9.1 m)	10'-0" (3.0 m)	30" (750mm)	24" (600mm)	8	6(19)
Greater than or equal to 30' (9.1 m) and less than 40' (12.2 m)	13'-6" (4.1 m)	30" (750mm)	24" (600mm)	8	6(19)
	11'-0" (3.4 m)	36" (900mm)	30" (750mm)	12	7(22)
Greater than or equal to 40' (12.2 m) and less than 50' (15.2 m)	13'-0" (4.0 m)	36" (900mm)	30" (750mm)	12	7(22)
	15'-0" (4.6 m)	36" (900mm)	30" (750mm)	12	7(22)
Greater than or equal to 56' (16.8 m) and less than 65' (19.8 m)	21'-0" (6.4 m)	42" (1060mm)	36" (900mm)	16	8(25)
Greater than or equal to 65' (19.8 m) and up to 75' (22.9 m)	25'-0" (7.6 m)	42" (1060mm)	36" (900mm)	16	8(25)

- NOTES:**
- These foundation depths are for sites which have cohesive soils (clayey silt, sandy clay, etc.) along the length of the shaft, with an average Unconfined Compressive Strength (Qu) > 1.0 tsf (100 kpa). This strength shall be verified by boring data prior to construction or with testing by the Engineer during foundation drilling. The Bureau of Bridges & structures should be contacted for a revised design if other conditions are encountered.
 - Combination mast arm assemblies under 55 feet (16.8 m) shall use 36" (900 mm) diameter foundations.
 - Combination mast arm assemblies under 56 feet (16.8 m) through 75 feet (22.9 m) shall use 42" (1060 mm) diameter foundations.
 - For mast arm assemblies with dual arms refer to state standard 878001.

DEPTH OF MAST ARM FOUNDATIONS, TYPE E

TS-06

FILE NAME =	USER NAME = kanthapixaybc	DESIGNED - DAG	REVISED -
cs:\pwork\PWIDOT\KANTHAPIXAYBC\d011264\tr of fic.legend.v7.dgn		DRAWN - BCK	REVISED -
		CHECKED - DAD	REVISED -
		DATE - 10/28/09	REVISED -

**STATE OF ILLINOIS
DEPARTMENT OF TRANSPORTATION**

**DISTRICT 1
STANDARD TRAFFIC SIGNAL DESIGN DETAILS**

SCALE: SHEET NO. OF SHEETS STA. TO STA.

F.A. RTE.	SECTION	COUNTY	TOTAL SHEETS	SHEET NO.
94	49-1-R-1	LAKE	677	337
FED. ROAD DIST. NO. ILLINOIS FED. AID PROJECT			CONTRACT NO. 60L77	

TRAFFIC SIGNAL LEGEND

ITEM	REMOVAL	EXISTING	PROPOSED	ITEM	REMOVAL	EXISTING	PROPOSED	ITEM	REMOVAL	EXISTING	PROPOSED
CONTROLLER CABINET				EMERGENCY VEHICLE LIGHT DETECTOR				ELECTRIC CABLE IN CONDUIT, TRACER, NO. 14 1/C, UNLESS NOTED OTHERWISE			
RAILROAD CONTROL CABINET				CONFIRMATION BEACON				COAXIAL CABLE			
COMMUNICATIONS CABINET				HANDHOLE				VENDOR CABLE FOR CAMERA			
MASTER CONTROLLER				HEAVY DUTY HANDHOLE				COPPER INTERCONNECT CABLE, NO. 18 3 PAIR TWISTED, SHIELDED			
MASTER MASTER CONTROLLER				DOUBLE HANDHOLE				FIBER OPTIC CABLE NO. 62.5/125, MM12F			
UNINTERRUPTIBLE POWER SUPPLY				JUNCTION BOX				FIBER OPTIC CABLE NO. 62.5/125, MM12F SM12F			
SERVICE INSTALLATION, (P) POLE OR (G) GROUND MOUNT				GALVANIZED STEEL CONDUIT IN TRENCH (T) OR PUSHED (P)				FIBER OPTIC CABLE NO. 62.5/125, MM12F 24F			
TELEPHONE CONNECTION (P) POLE OR (G) GROUND MOUNT				TEMPORARY SPAN WIRE, TETHER WIRE, AND CABLE				FIBER OPTIC CABLE NO. 62.5/125, MM12F 24F			
STEEL MAST ARM ASSEMBLY AND POLE				COMMON TRENCH				FIBER OPTIC CABLE NO. 62.5/125, (NUMBER OF FIBERS & TYPE TO BE NOTED ON PLANS)			
ALUMINUM MAST ARM ASSEMBLY AND POLE				COILABLE NONMETALLIC CONDUIT (EMPTY)				GROUND ROD AT (C) CONTROLLER, (H) HANDHOLE, (P) POST, (M) MAST ARM, OR (S) SERVICE			
STEEL COMBINATION MAST ARM ASSEMBLY AND POLE WITH LUMINAIRE				SYSTEM ITEM		S	S	CONTROLLER CABINET AND FOUNDATION TO BE REMOVED			
STEEL COMBINATION MAST ARM ASSEMBLY AND POLE WITH PTZ CAMERA				INTERSECTION ITEM		I	IP	STEEL MAST ARM POLE AND FOUNDATION TO BE REMOVED			
SIGNAL POST				REMOVE ITEM	R			ALUMINUM MAST ARM POLE AND FOUNDATION TO BE REMOVED			
TEMPORARY WOOD POLE (CLASS 5 OR BETTER) 45 FOOT (13.7m) MINIMUM				RELOCATE ITEM	RL			STEEL COMBINATION MAST ARM ASSEMBLY AND POLE WITH LUMINAIRE AND FOUNDATION TO BE REMOVED			
GUY WIRE				ABANDON ITEM	A			SIGNAL POST AND FOUNDATION TO BE REMOVED			
SIGNAL HEAD				12" (300mm) TRAFFIC SIGNAL SECTION				INTERSECTION & SAMPLING (SYSTEM) DETECTOR			
SIGNAL HEAD CONSTRUCTION STAGES (NUMBERS INDICATE THE CONSTRUCTION STAGE)				12" (300mm) RED WITH 8" (200mm) YELLOW AND GREEN TRAFFIC SIGNAL FACE				SAMPLING (SYSTEM) DETECTOR			
SIGNAL HEAD WITH BACKPLATE				SIGNAL FACE				EXISTING INTERSECTION LOOP DETECTOR PROPOSED INTERSECTION AND SAMPLING (SYSTEM) DETECTOR			
SIGNAL HEAD OPTICALLY PROGRAMMED				SIGNAL FACE WITH BACKPLATE, "P" INDICATES PROGRAMMED HEAD				EXISTING PREFORMED INTERSECTION LOOP DETECTOR PROPOSED INTERSECTION AND SAMPLING (SYSTEM) DETECTOR			
FLASHER INSTALLATION (S DENOTES SOLAR POWER)				12" (300mm) PEDESTRIAN SIGNAL HEAD WALK/DON'T WALK SYMBOL				PREFORMED INTERSECTION AND SAMPLING (SYSTEM) DETECTOR			
PEDESTRIAN SIGNAL HEAD				12" (300mm) PEDESTRIAN SIGNAL HEAD INTERNATIONAL SYMBOL, OUTLINED				PREFORMED SAMPLING (SYSTEM) DETECTOR			
PEDESTRIAN PUSHBUTTON DETECTOR				12" (300mm) PEDESTRIAN SIGNAL HEAD INTERNATIONAL SYMBOL, SOLID				RAILROAD SYMBOLS			
ACCESSIBLE PEDESTRIAN PUSHBUTTON DETECTOR				PEDESTRIAN SIGNAL HEAD, INTERNATIONAL SYMBOL, WITH COUNTDOWN TIMER				RAILROAD CONTROL CABINET			
ILLUMINATED SIGN "NO LEFT TURN"				RADIO INTERCONNECT				RAILROAD CANTILEVER MAST ARM			
ILLUMINATED SIGN "NO RIGHT TURN"				RADIO REPEATER				FLASHING SIGNAL			
DETECTOR LOOP, TYPE I				DENOTES NUMBER OF CONDUCTORS, ELECTRIC CABLE NO. 14, UNLESS NOTED OTHERWISE, ALL DETECTOR LOOP CABLE TO BE SHIELDED				CROSSING GATE			
PREFORMED DETECTOR LOOP				GROUND CABLE IN CONDUIT NO. 6 SOLID COPPER (GREEN)				CROSSBUCK			
MICROWAVE VEHICLE SENSOR											
VIDEO DETECTION CAMERA											
VIDEO DETECTION ZONE											
PAN, TILT, ZOOM CAMERA											
WIRELESS DETECTOR SENSOR											
WIRELESS ACCESS POINT											

NOTES FOR TEMPORARY TRAFFIC SIGNALS:

- ONLY CONTROLLERS SUPPLIED BY ONE OF THE DISTRICT APPROVED CLOSED LOOP EQUIPMENT MANUFACTURERS WILL BE APPROVED FOR USE AT TEMPORARY SIGNAL LOCATIONS. ALL CONTROLLERS USED FOR TEMPORARY TRAFFIC SIGNALS SHALL BE FULLY ACTUATED NEMA MICROPROCESSOR BASED WITH RS232 DATA ENTRY PORTS COMPATIBLE WITH EXISTING MONITORING SOFTWARE APPROVED BY IDOT DISTRICT 1, INSTALLED IN A NEMA TS1 OR TS2 CABINET. ONLY ONE BRAND OF CONTROLLER WILL BE ACCEPTED FOR ANY ONE CONTRACT.
- ALL TRAFFIC SIGNAL SECTIONS AND PEDESTRIAN SIGNAL SECTIONS SHALL BE LED AND 12" (300mm) DIAMETER. HEADS SHALL BE PLACED AS INDICATED ON THE TEMPORARY TRAFFIC SIGNAL PLAN OR AS DIRECTED BY THE ENGINEER. PEDESTRIAN SIGNALS SHALL INCLUDE SOLID INTERNATIONAL SYMBOLS. PEDESTRIAN SIGNALS WITH COUNTDOWN TIMERS SHALL BE USED WHEN THE EXISTING INSTALLATION UTILIZES COUNTDOWN TYPE OR AS DIRECTED BY THE ENGINEER. COUNTDOWN TYPE PEDESTRIAN SIGNALS ARE NOT TO BE INSTALLED AT A RAILROAD INTERSECTION. THE CONTRACTOR SHALL FURNISH ENOUGH CABLE SLACK TO RELOCATE HEADS TO ANY POSITION ON THE SPAN WIRE OR AT LOCATIONS ILLUSTRATED ON THE PLANS FOR CONSTRUCTION STAGING. THE TEMPORARY TRAFFIC SIGNAL SHALL REMAIN IN OPERATION DURING ALL SIGNAL HEAD RELOCATIONS. EACH TEMPORARY TRAFFIC SIGNAL HEAD SHALL HAVE ITS OWN CABLE FROM THE CONTROLLER CABINET TO THE SIGNAL HEAD.
- ALL EXISTING STREET NAME AND INTERSECTION REGULATORY SIGNS SHALL BE REMOVED FROM EXISTING POLES, RELOCATED AND SECURELY FASTENED TO THE SIGNAL SPAN WIRE OR WOOD POLE AS DIRECTED BY THE ENGINEER.
- ANY TEMPORARY SIGNAL WITHIN AN EXISTING CLOSED LOOP TRAFFIC SIGNAL SYSTEM SHALL BE INTERCONNECTED TO THAT SYSTEM USING SIMILAR BRAND CONTROL EQUIPMENT.
- TRAFFIC SIGNAL MANAGEMENT SYSTEMS SHALL BE MAINTAINED IN OPERATION AS INDICATED ON THE PLANS OR AS DIRECTED BY THE ENGINEER. REQUIRED EQUIPMENT SHALL BE AS SHOWN ON THE PLANS AND THE CONTRACTOR SHALL PLACE THE EQUIPMENT IN OPERATION TO THE SATISFACTION OF THE ENGINEER AND THE AGENCY RESPONSIBLE FOR THE TRAFFIC SIGNAL MANAGEMENT SYSTEM.
- DETECTION AT TEMPORARY TRAFFIC SIGNALS SHALL BE INCLUDED FOR ALL APPROACHES OF THE INTERSECTION UNLESS INDICATED OTHERWISE ON THE PLANS. THE DETECTION SYSTEM MUST MEET THE SPECIFICATIONS OF DISTRICT 1 AND THE CONTRACTOR SHALL PLACE THE DETECTORS INTO OPERATION TO THE SATISFACTION OF THE ENGINEER.
- SIGNAL HEAD SHALL BE BAGGED AND DE-ENERGIZED DURING STAGES 1A AND 2A. SIGNAL HEAD SHALL BE ACTIVATED DURING STAGE 1B.
- BAG AND DE-ENERGIZE LEFT TURN ARROW SECTIONS FOR THE DURATION OF STAGES 1A AND 2A. ACTIVATE LEFT TURN ARROW SECTIONS FOR THE DURATION OF STAGE 1B.
- BAG AND DE-ENERGIZE LEFT TURN ARROW SECTIONS FOR THE DURATION OF STAGE 1A. ROTATE SIGNAL HEAD TO FACE WESTBOUND TRAFFIC AND ACTIVATE LEFT TURN ARROW SECTIONS DURING STAGE 1B. BAG AND DE-ENERGIZE LEFT TURN ARROW SECTIONS AND ROTATE SIGNAL HEAD TO FACE EASTBOUND TRAFFIC FOR THE DURATION OF STAGE 2A.
- SIGNAL HEADS SHALL BE BAGGED AND DE-ENERGIZED FOR THE DURATION OF STAGE 1B. ACTIVATE DURING STAGES 1A AND 2A.
- CONTRACTOR SHALL PROGRAM A QUEUE DETECTOR FOR THE WESTBOUND LEFT TURN LANE AT THE DIRECTION OF THE ENGINEER FOR ANY STAGES WITHOUT A LEFT TURN LANE.
- RELOCATION OF EMERGENCY VEHICLE PREEMPTION EQUIPMENT AND VIDEO DETECTION EQUIPMENT FOR TEMPORARY TRAFFIC SIGNALS IS INCLUDED IN THE COST FOR TEMPORARY TRAFFIC SIGNAL INSTALLATION.

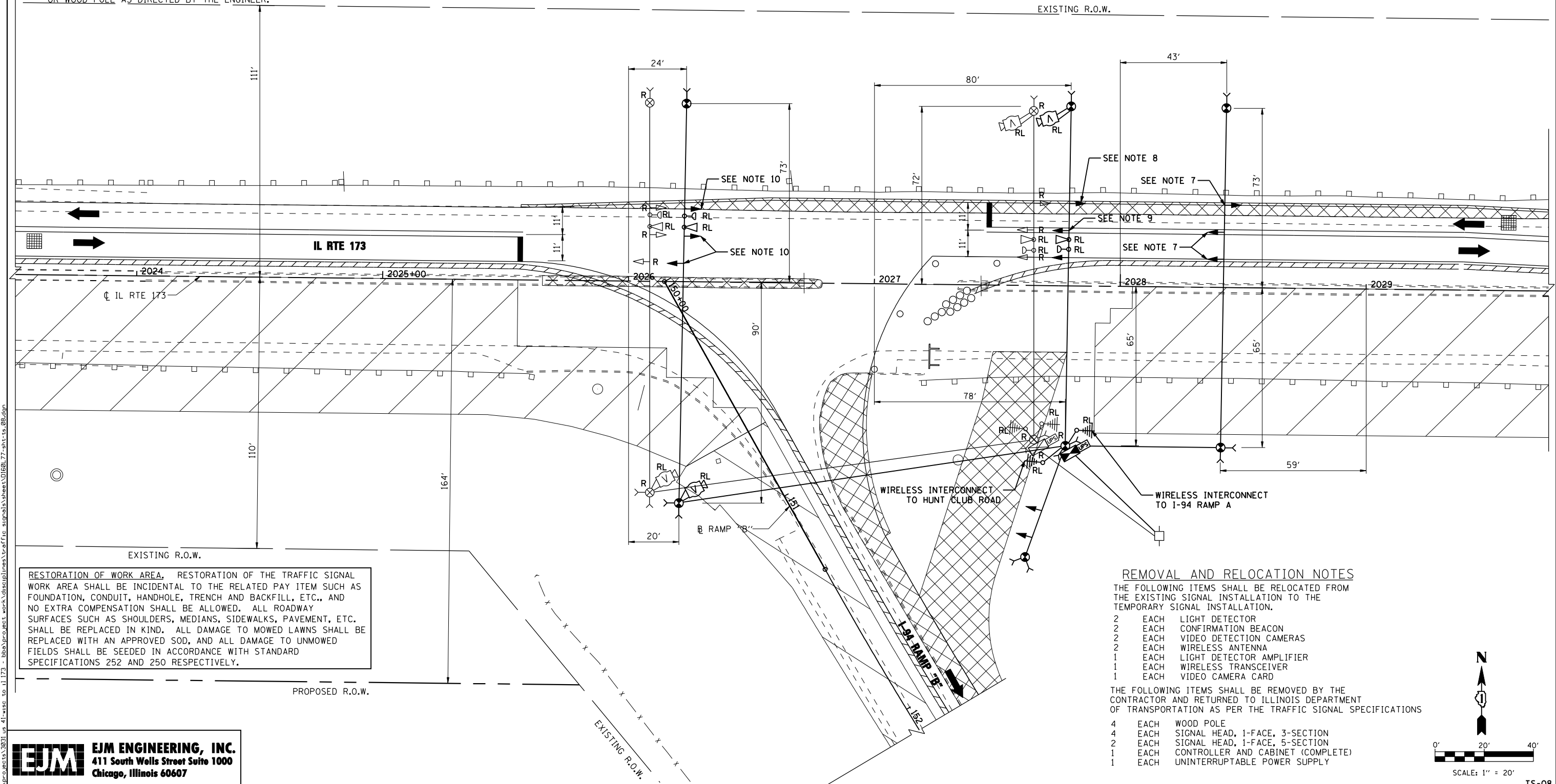

RESTORATION OF WORK AREA. RESTORATION OF THE TRAFFIC SIGNAL WORK AREA SHALL BE INCIDENTAL TO THE RELATED PAY ITEM SUCH AS FOUNDATION, CONDUIT, HANDHOLE, TRENCH AND BACKFILL, ETC., AND NO EXTRA COMPENSATION SHALL BE ALLOWED. ALL ROADWAY SURFACES SUCH AS SHOULDERS, MEDIANS, SIDEWALKS, PAVEMENT, ETC. SHALL BE REPLACED IN KIND. ALL DAMAGE TO MOWED LAWNS SHALL BE REPLACED WITH AN APPROVED SOD, AND ALL DAMAGE TO UNMOWED FIELDS SHALL BE SEEDING IN ACCORDANCE WITH STANDARD SPECIFICATIONS 252 AND 250 RESPECTIVELY.

REMOVAL AND RELOCATION NOTES

- THE FOLLOWING ITEMS SHALL BE RELOCATED FROM THE EXISTING SIGNAL INSTALLATION TO THE TEMPORARY SIGNAL INSTALLATION.
- 2 EACH LIGHT DETECTOR
 - 2 EACH CONFIRMATION BEACON
 - 2 EACH VIDEO DETECTION CAMERAS
 - 2 EACH WIRELESS ANTENNA
 - 1 EACH LIGHT DETECTOR AMPLIFIER
 - 1 EACH WIRELESS TRANSCIVER
 - 1 EACH VIDEO CAMERA CARD
- THE FOLLOWING ITEMS SHALL BE REMOVED BY THE CONTRACTOR AND RETURNED TO ILLINOIS DEPARTMENT OF TRANSPORTATION AS PER THE TRAFFIC SIGNAL SPECIFICATIONS
- 4 EACH WOOD POLE
 - 4 EACH SIGNAL HEAD, 1-FACE, 3-SECTION
 - 2 EACH SIGNAL HEAD, 1-FACE, 5-SECTION
 - 1 EACH CONTROLLER AND CABINET (COMPLETE)
 - 1 EACH UNINTERRUPTABLE POWER SUPPLY

EJM ENGINEERING, INC.
 411 South Wells Street Suite 1000
 Chicago, Illinois 60607

FILE NAME =	USER NAME = gra1	DESIGNED - GR	REVISED -
		DRAWN - GR	REVISED -
		CHECKED - BKS	REVISED -
		DATE - 06/19/2012	REVISED -

**STATE OF ILLINOIS
 DEPARTMENT OF TRANSPORTATION**

**TEMPORARY TRAFFIC SIGNAL INSTALLATION
 IL RTE 173 AT I-94 RAMP "B" - STAGE 1A**

SCALE: 1" = 20' SHEET NO. 1 OF 1 SHEETS STA. 2023+52 TO STA. 2029+75

F.A.I. RTE.	SECTION	COUNTY	TOTAL SHEETS	SHEET NO.
94	49-1-R-1	LAKE	677	339
CONTRACT NO. 60L77			ILLINOIS FED. AID PROJECT	

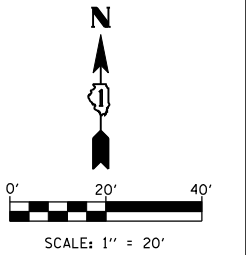

TS-08

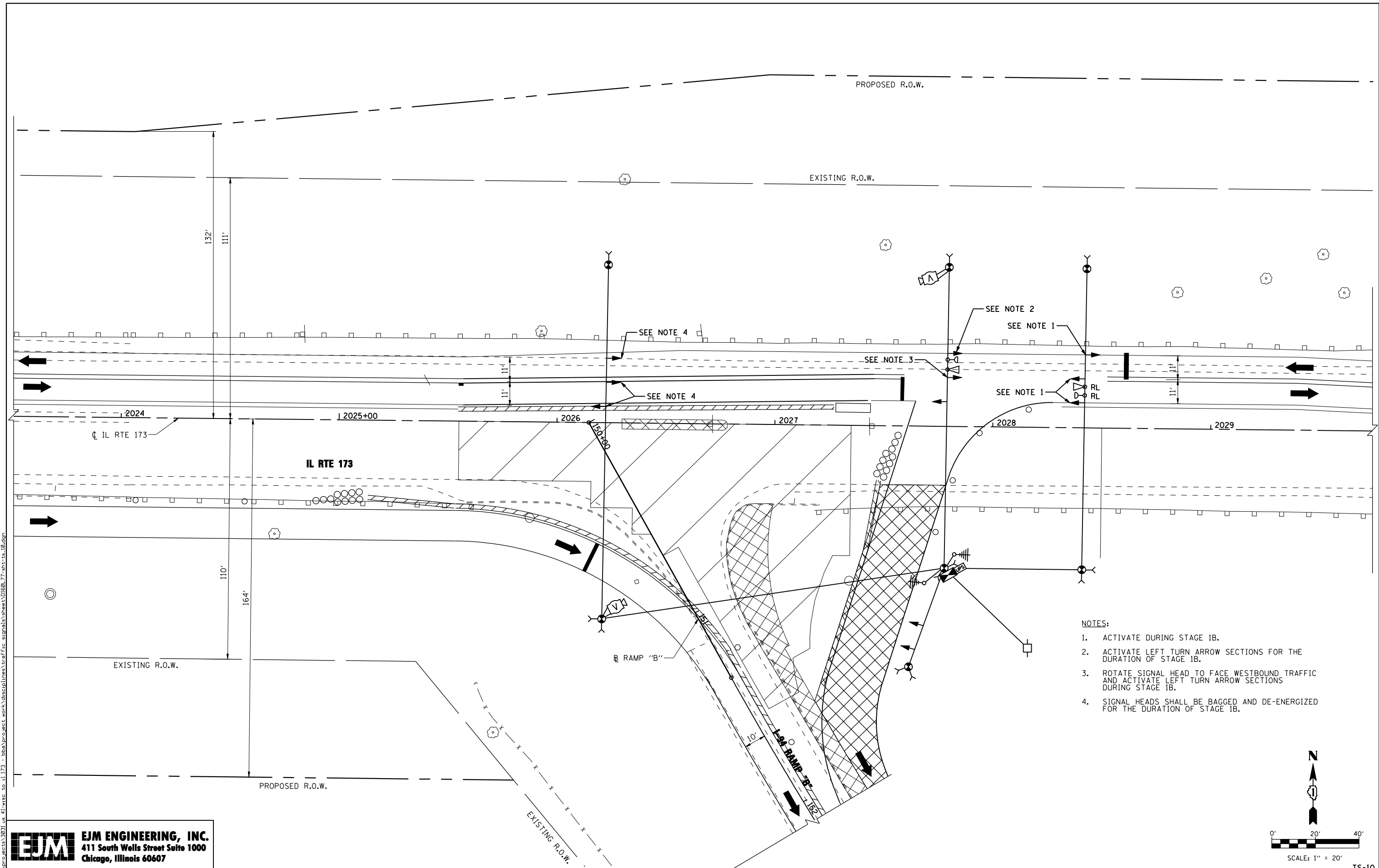

- NOTES:**
1. ACTIVATE DURING STAGE 1B.
 2. ACTIVATE LEFT TURN ARROW SECTIONS FOR THE DURATION OF STAGE 1B.
 3. ROTATE SIGNAL HEAD TO FACE WESTBOUND TRAFFIC AND ACTIVATE LEFT TURN ARROW SECTIONS DURING STAGE 1B.
 4. SIGNAL HEADS SHALL BE BAGGED AND DE-ENERGIZED FOR THE DURATION OF STAGE 1B.

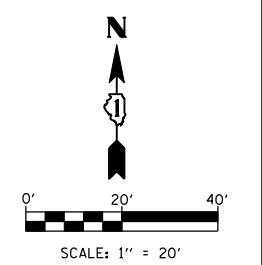

EJM ENGINEERING, INC.
 411 South Wells Street Suite 1000
 Chicago, Illinois 60607

FILE NAME =	USER NAME = grai	DESIGNED - GR	REVISED -
		DRAWN - GR	REVISED -
	PLOT SCALE = 40,0000' / IN.	CHECKED - BKS	REVISED -
	PLOT DATE = 6/18/2012	DATE - 06/19/2012	REVISED -

**STATE OF ILLINOIS
 DEPARTMENT OF TRANSPORTATION**

**TEMPORARY TRAFFIC SIGNAL INSTALLATION
 IL RTE 173 AT I-94 RAMP "B" - STAGE 1B**

SCALE: 1" = 20' SHEET NO. 1 OF 1 SHEETS STA. 2023+52 TO STA. 2029+75

F.A.I. RTE.	SECTION	COUNTY	TOTAL SHEETS	SHEET NO.
94	49-1-R-1	LAKE	677	341
CONTRACT NO. 60L77			ILLINOIS FED. AID PROJECT	

TS-10

NOTES:

1. BAG AND DE-ENERGIZE SIGNAL HEADS DURING STAGE 2A.
2. BAG AND DE-ENERGIZE LEFT TURN ARROW SECTIONS FOR THE DURATION OF STAGE 2A.
3. BAG AND DE-ENERGIZE LEFT TURN ARROW SECTIONS AND ROTATE SIGNAL HEAD TO FACE EASTBOUND TRAFFIC FOR THE DURATION OF STAGE 2A.
4. SIGNAL HEADS SHALL BE ACTIVATED DURING STAGE 2A.

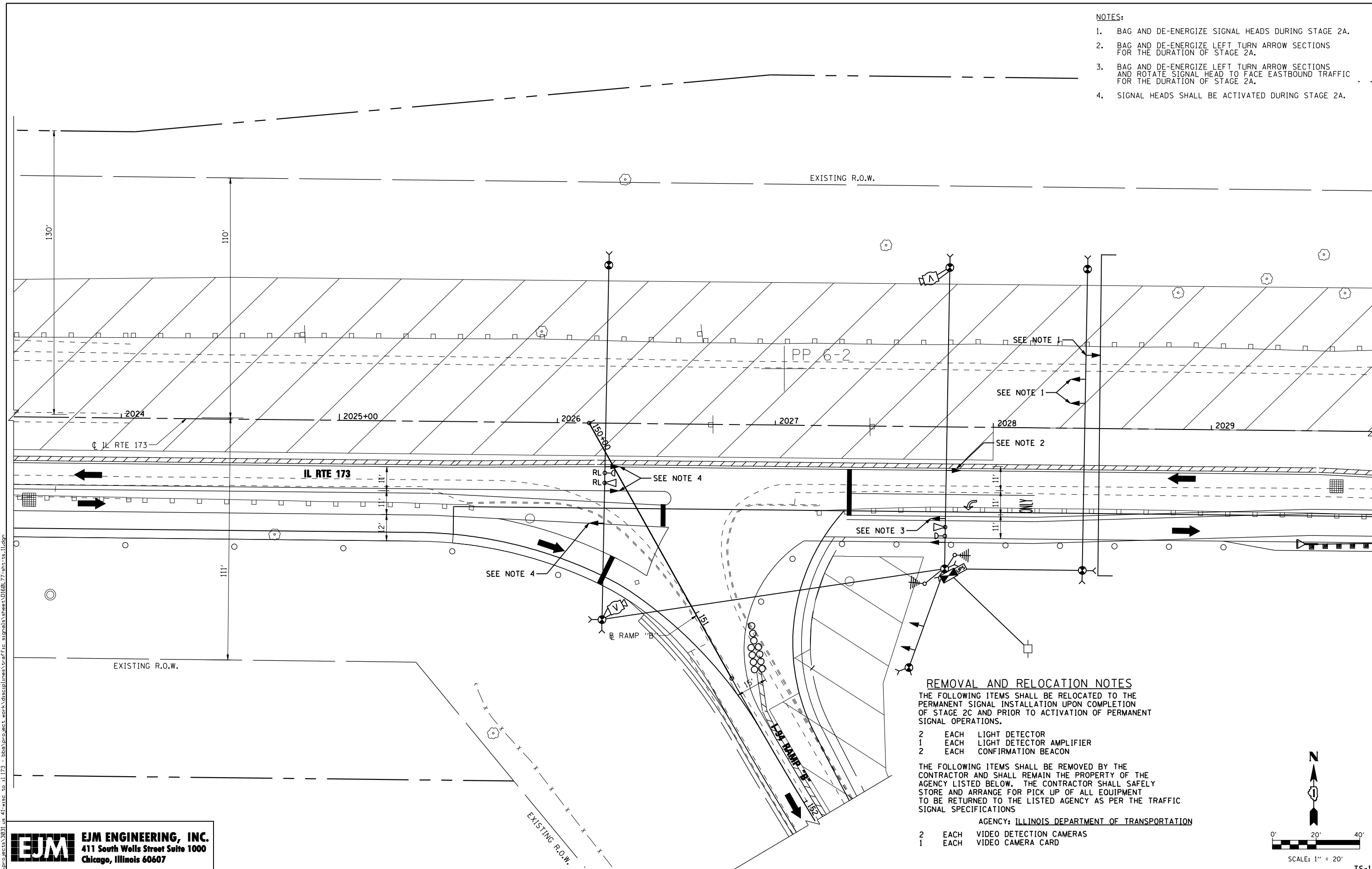

REMOVAL AND RELOCATION NOTES

THE FOLLOWING ITEMS SHALL BE RELOCATED TO THE PERMANENT SIGNAL INSTALLATION UPON COMPLETION OF STAGE 2C AND PRIOR TO ACTIVATION OF PERMANENT SIGNAL OPERATIONS.

- 2 EACH LIGHT DETECTOR
- 1 EACH LIGHT DETECTOR AMPLIFIER
- 2 EACH CONFIRMATION BEACON

THE FOLLOWING ITEMS SHALL BE REMOVED BY THE CONTRACTOR AND SHALL REMAIN THE PROPERTY OF THE AGENCY LISTED BELOW. THE CONTRACTOR SHALL SAFELY STORE AND ARRANGE FOR PICK UP OF ALL EQUIPMENT TO BE RETURNED TO THE LISTED AGENCY AS PER THE TRAFFIC SIGNAL SPECIFICATIONS

- 2 EACH VIDEO DETECTION CAMERAS
- 1 EACH VIDEO CAMERA CARD

AGENCY: ILLINOIS DEPARTMENT OF TRANSPORTATION

EJM ENGINEERING, INC.
 411 South Wells Street Suite 1000
 Chicago, Illinois 60607

FILE NAME =	USER NAME = gra1	DESIGNED - GR	REVISED -
		DRAWN - GR	REVISED -
		CHECKED - BKS	REVISED -
		DATE - 06/19/2012	REVISED -

**STATE OF ILLINOIS
 DEPARTMENT OF TRANSPORTATION**

**TEMPORARY TRAFFIC SIGNAL INSTALLATION
 IL RTE 173 AT I-94 RAMP "B" - STAGE 2A**

SCALE: 1" = 20' SHEET NO. 1 OF 1 SHEETS STA. 2023+52 TO STA. 2029+75

F.A.I. RTE.	SECTION	COUNTY	TOTAL SHEETS	SHEET NO.
94	49-1-R-1	LAKE	677	342
CONTRACT NO. 60L77			ILLINOIS FED. AID PROJECT	

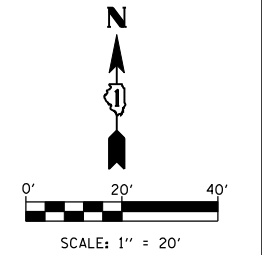

TS-11

RESTORATION OF WORK AREA, RESTORATION OF THE TRAFFIC SIGNAL WORK AREA SHALL BE INCIDENTAL TO THE RELATED PAY ITEM SUCH AS FOUNDATION, CONDUIT, HANDHOLE, TRENCH AND BACKFILL, ETC., AND NO EXTRA COMPENSATION SHALL BE ALLOWED. ALL ROADWAY SURFACES SUCH AS SHOULDERS, MEDIANS, SIDEWALKS, PAVEMENT, ETC. SHALL BE REPLACED IN KIND. ALL DAMAGE TO MOWED LAWNS SHALL BE REPLACED WITH AN APPROVED SOD, AND ALL DAMAGE TO UNMOWED FIELDS SHALL BE SEEDED IN ACCORDANCE WITH STANDARD SPECIFICATIONS 252 AND 250 RESPECTIVELY.

NOTES:

- EMERGENCY VEHICLE PREEMPTION EQUIPMENT SHALL BE RELOCATED FROM THE TEMPORARY SIGNAL INSTALLATION.
- THE PTZ CAMERA SHALL BE MOUNTED ON THE LUMINAIRE MAST ARM AS DIRECTED BY THE ENGINEER. PTZ MOUNTING TO BE COORDINATED WITH LAKE COUNTY DIVISION OF TRANSPORTATION.
- RELOCATE EXISTING SWITCH (SPECIAL) (1 EA) FROM EXISTING HAR CABINET (SEE SHEET TS-13) TO TRAFFIC SIGNAL CABINET. INSTALL VIDEO ENCODER (1 EA) AND TERMINAL SERVER (1 EA) IN THE TRAFFIC SIGNAL CABINET.

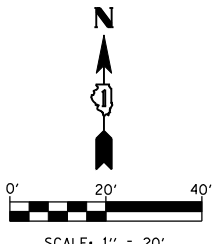
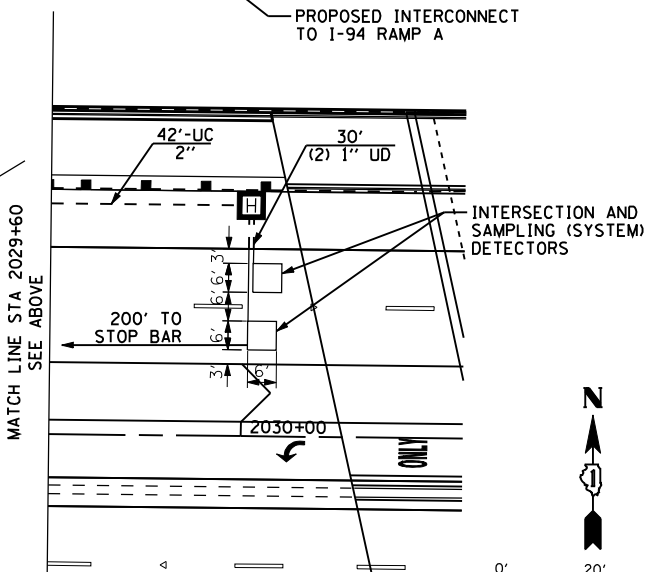
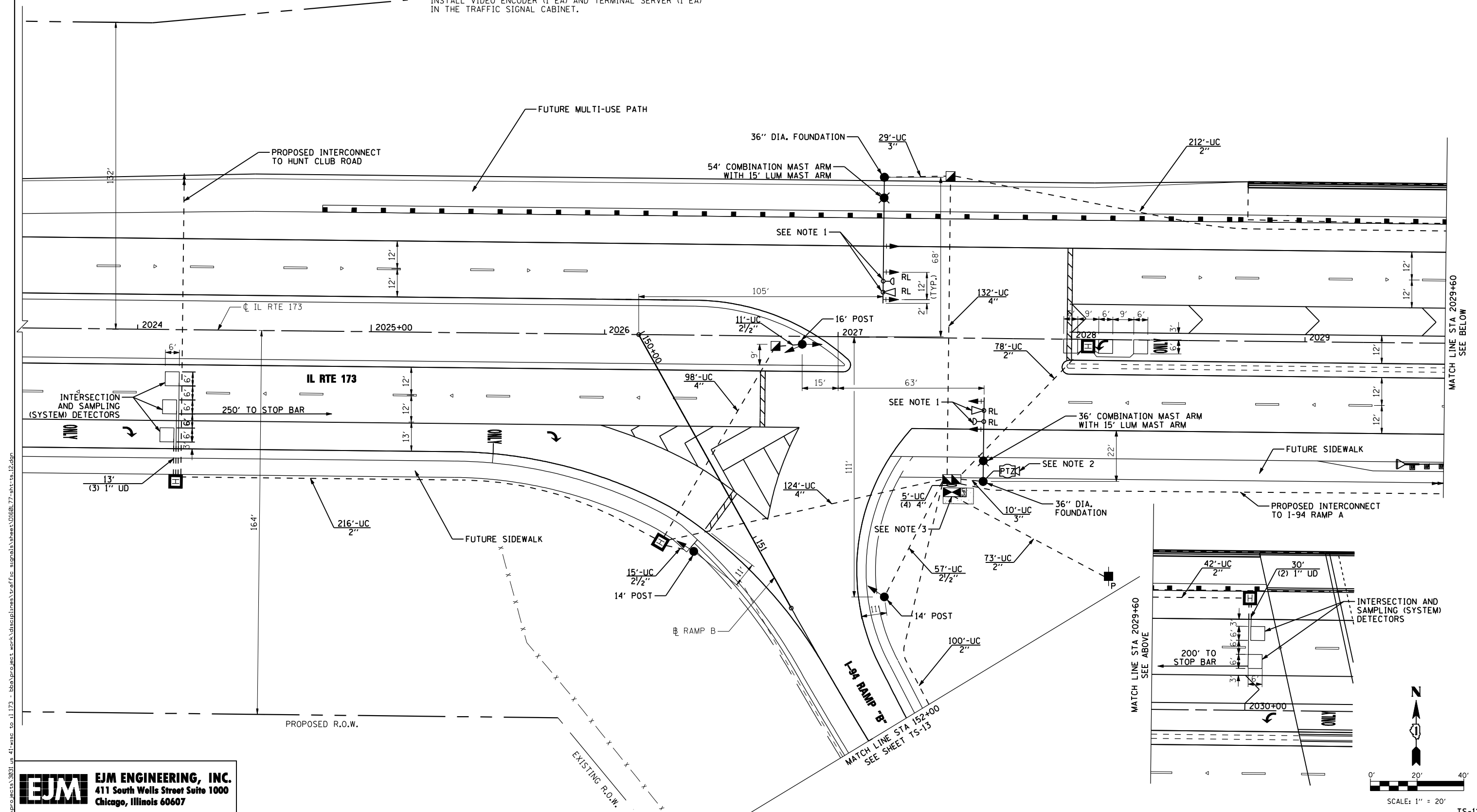

s:\projects\3021.us_41-usa-to-11-173-bba\p\sect-work\disiplines\tr-off\tr-signal\sheet\01606L77-sht-ts-12.dwg

EJM ENGINEERING, INC.
411 South Wells Street Suite 1000
Chicago, Illinois 60607

FILE NAME =	USER NAME = gra1	DESIGNED - GR	REVISED -
		DRAWN - GR	REVISED -
	PLOT SCALE = 40,0000' / IN.	CHECKED - BKS	REVISED -
	PLOT DATE = 6/18/2012	DATE - 06/19/2012	REVISED -

**STATE OF ILLINOIS
DEPARTMENT OF TRANSPORTATION**

**TRAFFIC SIGNAL INSTALLATION
IL RTE 173 AT I-94 RAMP "B"**

SCALE: 1" = 20' SHEET NO. 1 OF 1 SHEETS STA. 2023+52 TO STA. 2030+46

F.A.I. RTE.	SECTION	COUNTY	TOTAL SHEETS	SHEET NO.
94	49-1-R-1	LAKE	677	343
ILLINOIS FED. AID PROJECT			CONTRACT NO. 60L77	

TS-12

s:\projects\3021.us_41-usa_to_11.172 - bba\proj\sect_work\disiplines\tr-offic_signals\shes\0160L77-shr-ts.13.dgn

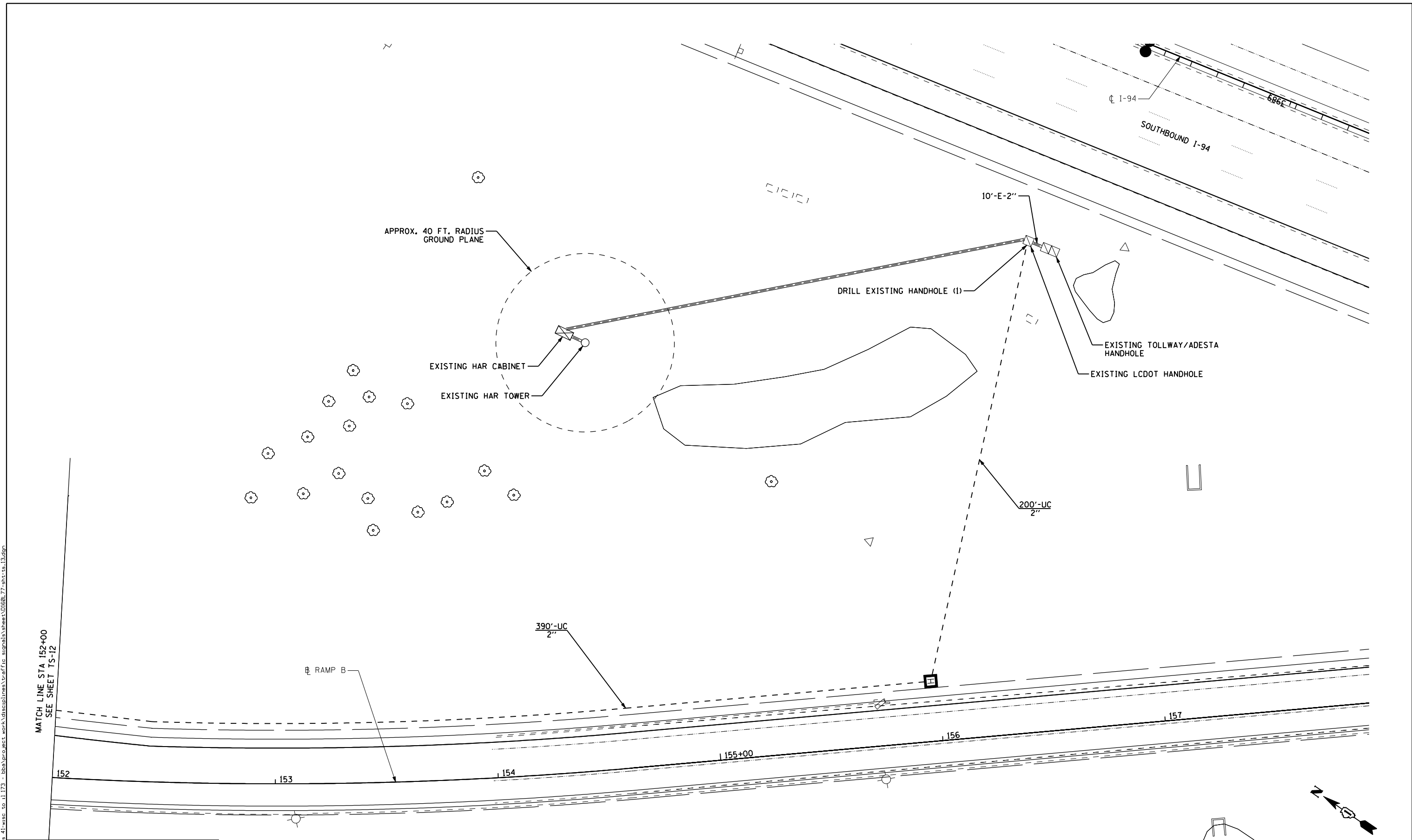

EJM ENGINEERING, INC.
 411 South Wells Street Suite 1000
 Chicago, Illinois 60607

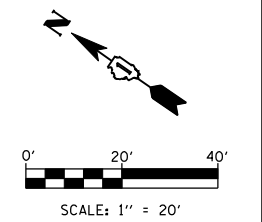

FILE NAME =	USER NAME = gra1	DESIGNED - GR	REVISED -
		DRAWN - GR	REVISED -
	PLOT SCALE = 40,0000 ' / IN.	CHECKED - BKS	REVISED -
	PLOT DATE = 6/18/2012	DATE - 06/19/2012	REVISED -

STATE OF ILLINOIS
DEPARTMENT OF TRANSPORTATION

HAR TOWER
I-94 RAMP "B" INFIELD

SCALE: 1" = 20' SHEET NO. 1 OF 1 SHEETS STA. 152+00 TO STA. 157+92

F.A.I. RTE.	SECTION	COUNTY	TOTAL SHEETS	SHEET NO.
94	49-1-R-1	LAKE	677	344
CONTRACT NO. 60L77			ILLINOIS FED. AID PROJECT	

TS-13

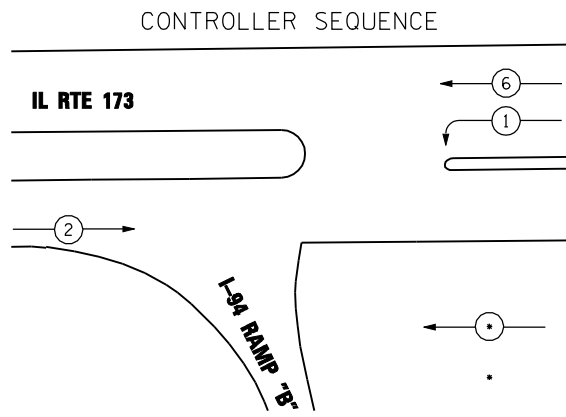

PHASE DESIGNATION DIAGRAM

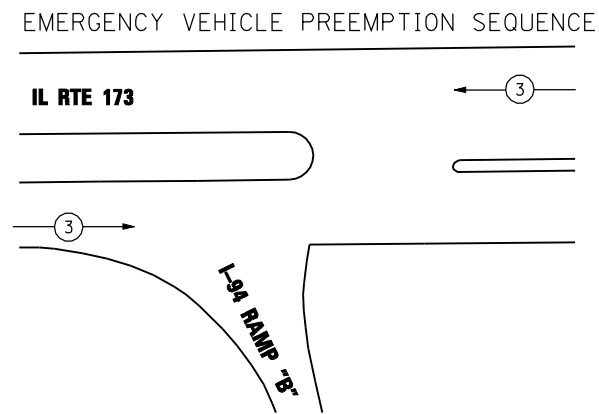

PROPOSED EMERGENCY VEHICLE PREEMPTORS	
EMERGENCY VEHICLE PREEMPTOR	3
MOVEMENT	← →

s:\projects\3031.us_41-usse-to-11.173 - bba\p\proj\est\work\desig\lines\tr-off\fig_signals\sheet\1606.77-shr-ts-14.dgn

I.D.O.T.
TRAFFIC SIGNAL INSTALLATION
ELECTRICAL SERVICE REQUIREMENTS

TYPE	NO. OF LAMPS	WATTAGE		% OPERATIONS	TOTAL
		INCAND.	LED		
SIGNAL (RED)	9	135	17	0.50	76.5
(YELLOW)	9	135	25	0.25	56.25
(GREEN)	9	135	15	0.25	33.75
ARROW	4	135	12	0.10	4.8
PED. SIGNAL	-	90	25	1.00	-
CONTROLLER	1	100	100	1.00	100
ILLUM. SIGN	-	-	25	0.50	-
PTZ CAMERA	1	65	-	1.00	65

ENERGY COSTS TO: TOTAL = 336.3

ILLINOIS DEPARTMENT OF TRANSPORTATION

DIVISION OF HIGHWAYS/DISTRICT 1
201 WEST CENTER COURT/SCHAUMBURG, IL 60196

ENERGY SUPPLY: CONTACT: DOROTHY PROSEN
PHONE: (847) 816-5323
COMPANY: COM ED



SCHEDULE OF QUANTITIES

CODE NUMBER	ITEM	UNIT	TOTAL
80500020	SERVICE INSTALLATION - POLE MOUNTED	EACH	1
81028200	UNDERGROUND CONDUIT, GALVANIZED STEEL, 2" DIA.	FOOT	1311
81028210	UNDERGROUND CONDUIT, GALVANIZED STEEL, 2 1/2" DIA.	FOOT	83
81028220	UNDERGROUND CONDUIT, GALVANIZED STEEL, 3" DIA.	FOOT	39
81028240	UNDERGROUND CONDUIT, GALVANIZED STEEL, 4" DIA.	FOOT	374
81400100	HANDHOLE	EACH	2
81400200	HEAVY-DUTY HANDHOLE	EACH	5
81400300	DOUBLE HANDHOLE	EACH	1
86400100	TRANSCIVER - FIBER OPTIC	EACH	1
87300925	ELECTRIC CABLE IN CONDUIT, TRACER, NO. 14 1C	FOOT	748
87301225	ELECTRIC CABLE IN CONDUIT, SIGNAL NO. 14 3C	FOOT	453
87301245	ELECTRIC CABLE IN CONDUIT, SIGNAL NO. 14 5C	FOOT	1325
87301255	ELECTRIC CABLE IN CONDUIT, SIGNAL NO. 14 7C	FOOT	574
87301305	ELECTRIC CABLE IN CONDUIT, LEAD-IN, NO. 14 1 PAIR	FOOT	2077
87301805	ELECTRIC CABLE IN CONDUIT, SERVICE, NO. 6 2 C	FOOT	106
87301900	ELECTRIC CABLE IN CONDUIT, EQUIPMENT GROUNDING CONDUCTOR, NO. 6 1C	FOOT	757
87502480	TRAFFIC SIGNAL POST, GALVANIZED STEEL 14 FT.	EACH	2
87502500	TRAFFIC SIGNAL POST, GALVANIZED STEEL 16 FT.	EACH	1
87702990	STEEL COMBINATION MAST ARM ASSEMBLY AND POLE 54 FT.	EACH	1
87702910	STEEL COMBINATION MAST ARM ASSEMBLY AND POLE 36 FT.	EACH	1
87800100	CONCRETE FOUNDATION, TYPE A	FOOT	12
87800150	CONCRETE FOUNDATION, TYPE C	FOOT	4
87800415	CONCRETE FOUNDATION, TYPE E 36-INCH DIAMETER	FOOT	26
87900200	DRILL EXISTING HANDHOLE	EACH	1
88030020	SIGNAL HEAD, LED, 1-FACE, 3-SECTION, MAST-ARM MOUNTED	EACH	4
88030050	SIGNAL HEAD, LED, 1-FACE, 3-SECTION, BRACKET MOUNTED	EACH	2
88030110	SIGNAL HEAD, LED, 1-FACE, 5-SECTION, MAST-ARM MOUNTED	EACH	1
88030240	SIGNAL HEAD, LED, 2-FACE, 1-3 SECTION, 1-5 SECTION, BRACKET MOUNTED	EACH	1
88200210	TRAFFIC SIGNAL BACKPLATE, LOUVERED, ALUMINUM	EACH	5
88500100	INDUCTIVE LOOP DETECTOR	EACH	6
88600700	PREFORMED DETECTOR LOOP	FOOT	279
89000100	TEMPORARY TRAFFIC SIGNAL INSTALLATION	EACH	1
89502375	REMOVE EXISTING TRAFFIC SIGNAL EQUIPMENT	EACH	1
X0324085	EMERGENCY VEHICLE PRIORITY SYSTEM LINE SENSOR CABLE, NO. 20 3/C	FOOT	378
85700200	FULL-ACTUATED CONTROLLER AND TYPE IV CABINET	EACH	1
X8620200	UNINTERRUPTABLE POWER SUPPLY, SPECIAL	EACH	1
X8710024	FIBER OPTIC CABLE IN CONDUIT, NO. 62.5/125, MM12F 5M24F	FOOT	748
X8730800	ELECTRIC CABLE IN CONDUIT, VIDEO, NO. 20 4 C	FOOT	76
X8950115	RELOCATE LIGHT DETECTOR	EACH	2
X8950120	RELOCATE LIGHT DETECTOR AMPLIFIER	EACH	1
Z0073510	TEMPORARY TRAFFIC SIGNAL TIMING	EACH	1
XX005940	REMOTE-CONTROLLED VIDEO SYSTEM	EACH	1
XX007952	TERMINAL SERVER	EACH	1
XX008253	VIDEO ENCODER	EACH	1
X0327211	ELECTRIC CABLE IN CONDUIT, COAXIAL	FOOT	76
X0327211	RELOCATE SWITCH	EACH	1
X0327211	RELOCATE VIDEO VEHICLE DETECTION SYSTEM	EACH	1
X0327211	ELECTRIC CABLE, COMMUNICATION, NO.22 4 PAIR	FOOT	942

CABLE PLAN

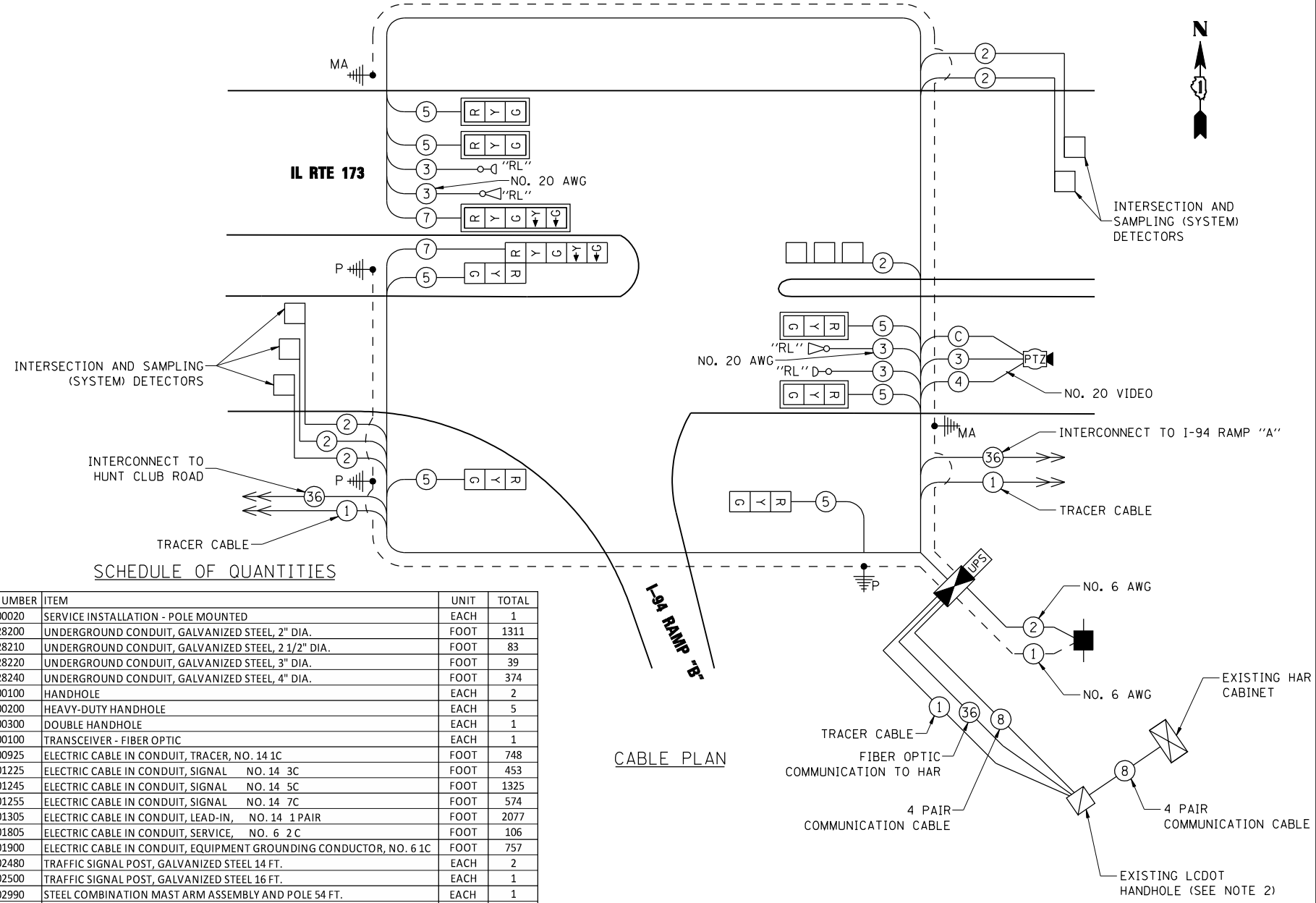

RESTORATION OF WORK AREA, RESTORATION OF THE TRAFFIC SIGNAL WORK AREA SHALL BE INCIDENTAL TO THE RELATED PAY ITEM SUCH AS FOUNDATION, CONDUIT, HANDHOLE, TRENCH AND BACKFILL, ETC., AND NO EXTRA COMPENSATION SHALL BE ALLOWED. ALL ROADWAY SURFACES SUCH AS SHOULDERS, MEDIANS, SIDEWALKS, PAVEMENT, ETC. SHALL BE REPLACED IN KIND. ALL DAMAGE TO MOWED LAWNS SHALL BE REPLACED WITH AN APPROVED SOD, AND ALL DAMAGE TO UNMOWED FIELDS SHALL BE SEEDED IN ACCORDANCE WITH STANDARD SPECIFICATIONS 252 AND 250 RESPECTIVELY.

- NOTES:
- THE EMERGENCY VEHICLE PREEMPTION EQUIPMENT SHALL BE RELOCATED FROM THE TEMPORARY TRAFFIC SIGNAL INSTALLATION.
 - FIBER OPTIC CABLE SHALL BE SPLICED IN THE EXISTING SPLICE ENCLOSURE AT THE TOLLWAY/ADESTA HANDHOLE. SEE SHEET TS-15 FOR SPLICING DETAILS.

FILE NAME =	USER NAME = gcr1	DESIGNED - GR	REVISED -
		DRAWN - GR	REVISED -
	PLOT SCALE = none	CHECKED - BKS	REVISED -
	PLOT DATE = 6/18/2012	DATE - 06/19/2012	REVISED -

STATE OF ILLINOIS
DEPARTMENT OF TRANSPORTATION

SCHEDULE OF QUANTITIES, CABLE PLAN,
AND PHASE DESIGNATION DIAGRAM
IL RTE 173 AT I-94 RAMP "B"

SCALE: NONE SHEET NO. 1 OF 1 SHEETS STA. TO STA.

F.A.I. RTE.	SECTION	COUNTY	TOTAL SHEETS	SHEET NO.
94	49-1-R-1	LAKE	677	345
CONTRACT NO.			60L77	
ILLINOIS FED. AID PROJECT				

TS-14

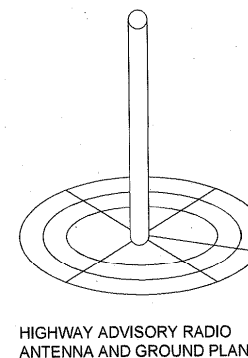
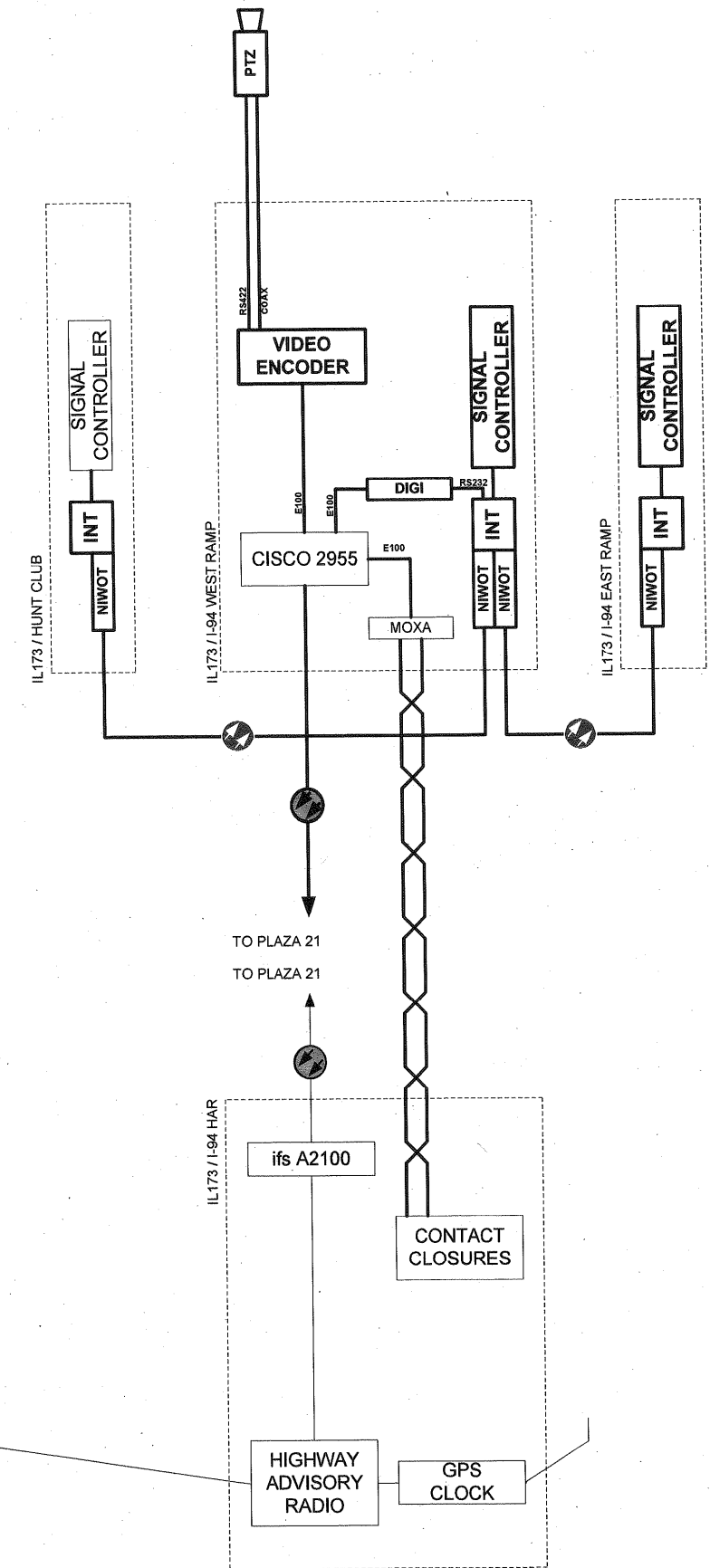
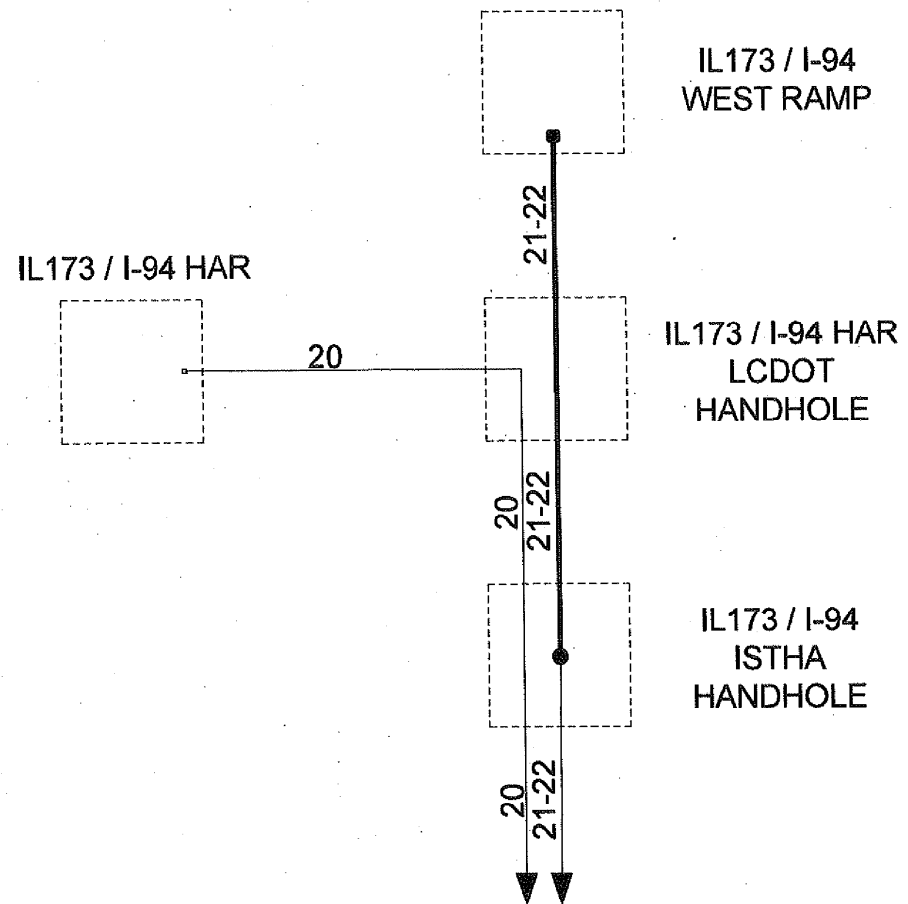
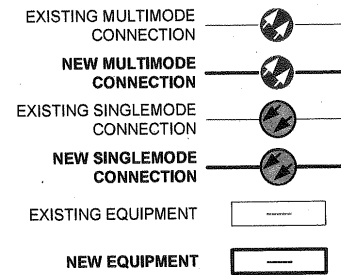
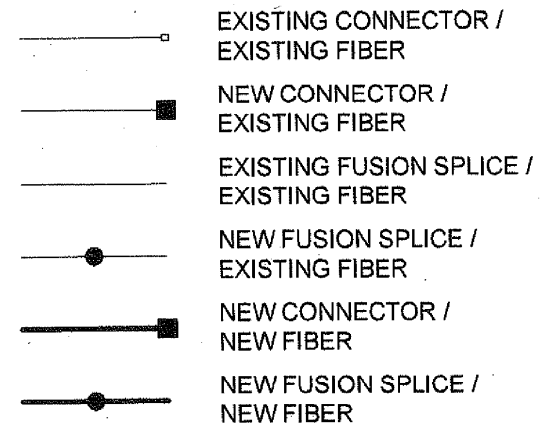

s:\projects\3021.us_41-usa_to_il173 - bba\project_work\disciplines\tr-offic_signals\sheet\0160L77-sht-ts_15.dgn



FILE NAME =	USER NAME = grai	DESIGNED - GR	REVISED -
		DRAWN - GR	REVISED -
	PLOT SCALE = none	CHECKED - BKS	REVISED -
	PLOT DATE = 6/18/2012	DATE - 06/19/2012	REVISED -

STATE OF ILLINOIS
DEPARTMENT OF TRANSPORTATION

FIBER OPTIC CABLE SPLIC DETAIL
IL RTE 173 AT I-94 RAMP "B" INFIELD

SCALE: NONE SHEET NO. 1 OF 1 SHEETS STA. TO STA.

F.A.I. RTE.	SECTION	COUNTY	TOTAL SHEETS	SHEET NO.
94	49-1-R-1	LAKE	677	346
CONTRACT NO.			60L77	
ILLINOIS FED. AID PROJECT				

TS-15

NOTES FOR TEMPORARY TRAFFIC SIGNALS:

1. ONLY CONTROLLERS SUPPLIED BY ONE OF THE DISTRICT APPROVED CLOSED LOOP EQUIPMENT MANUFACTURERS WILL BE APPROVED FOR USE AT TEMPORARY SIGNAL LOCATIONS. ALL CONTROLLERS USED FOR TEMPORARY TRAFFIC SIGNALS SHALL BE FULLY ACTUATED NEMA MICROPROCESSOR BASED WITH RS232 DATA ENTRY PORTS COMPATIBLE WITH EXISTING MONITORING SOFTWARE APPROVED BY IDOT DISTRICT 1, INSTALLED IN A NEMA TS1 OR TS2 CABINET. ONLY ONE BRAND OF CONTROLLER WILL BE ACCEPTED FOR ANY ONE CONTRACT.
2. ALL TRAFFIC SIGNAL SECTIONS AND PEDESTRIAN SIGNAL SECTIONS SHALL BE LED AND 12" (300mm) DIAMETER. HEADS SHALL BE PLACED AS INDICATED ON THE TEMPORARY TRAFFIC SIGNAL PLAN OR AS DIRECTED BY THE ENGINEER. PEDESTRIAN SIGNALS SHALL INCLUDE SOLID INTERNATIONAL SYMBOLS. PEDESTRIAN SIGNALS WITH COUNTDOWN TIMERS SHALL BE USED WHEN THE EXISTING INSTALLATION UTILIZES COUNTDOWN TYPE OR AS DIRECTED BY THE ENGINEER. COUNTDOWN TYPE PEDESTRIAN SIGNALS ARE NOT TO BE INSTALLED AT A RAILROAD INTERSECTION. THE CONTRACTOR SHALL FURNISH ENOUGH CABLE SLACK TO RELOCATE HEADS TO ANY POSITION ON THE SPAN WIRE OR AT LOCATIONS ILLUSTRATED ON THE PLANS FOR CONSTRUCTION STAGING. THE TEMPORARY TRAFFIC SIGNAL SHALL REMAIN IN OPERATION DURING ALL SIGNAL HEAD RELOCATIONS. EACH TEMPORARY TRAFFIC SIGNAL HEAD SHALL HAVE ITS OWN CABLE FROM THE CONTROLLER CABINET TO THE SIGNAL HEAD.

3. ALL EXISTING STREET NAME AND INTERSECTION REGULATORY SIGNS SHALL BE REMOVED FROM EXISTING POLES, RELOCATED AND SECURELY FASTENED TO THE SIGNAL SPAN WIRE OR WOOD POLE AS DIRECTED BY THE ENGINEER.
4. ANY TEMPORARY SIGNAL WITHIN AN EXISTING CLOSED LOOP TRAFFIC SIGNAL SYSTEM SHALL BE INTERCONNECTED TO THAT SYSTEM USING SIMILAR BRAND CONTROL EQUIPMENT.
5. TRAFFIC SIGNAL MANAGEMENT SYSTEMS SHALL BE MAINTAINED IN OPERATION AS INDICATED ON THE PLANS OR AS DIRECTED BY THE ENGINEER. REQUIRED EQUIPMENT SHALL BE AS SHOWN ON THE PLANS AND THE CONTRACTOR SHALL PLACE THE EQUIPMENT IN OPERATION TO THE SATISFACTION OF THE ENGINEER AND THE AGENCY RESPONSIBLE FOR THE TRAFFIC SIGNAL MANAGEMENT SYSTEM.
6. DETECTION AT TEMPORARY TRAFFIC SIGNALS SHALL BE INCLUDED FOR ALL APPROACHES OF THE INTERSECTION UNLESS INDICATED OTHERWISE ON THE PLANS. THE DETECTION SYSTEM MUST MEET THE SPECIFICATIONS OF DISTRICT 1 AND THE CONTRACTOR SHALL PLACE THE DETECTORS INTO OPERATION TO THE SATISFACTION OF THE ENGINEER.
7. SIGNAL HEAD SHALL BE BAGGED AND DE-ENERGIZED PRIOR TO ACTIVATION OF THIS STAGE.

8. SIGNAL HEAD SHALL BE BAGGED AND DE-ENERGIZED AT THE END OF THIS STAGE, PRIOR TO BEGINNING OF STAGE 1B.
9. SIGNAL HEAD SHALL BE ROTATED TO FACE EASTBOUND TRAFFIC DURING THIS STAGE. AT THE END OF THIS STAGE AND PRIOR TO BEGINNING OF STAGE 1B, SIGNAL HEAD SHALL BE ROTATED TO FACE WESTBOUND TRAFFIC.
10. TEMPORARY SIGN AND MOUNTING IS INCIDENTAL TO THE COST OF TEMPORARY SIGNAL INSTALLATION.
11. RELOCATION OF EMERGENCY VEHICLE PREEMPTION EQUIPMENT AND VIDEO DETECTION EQUIPMENT FOR TEMPORARY TRAFFIC SIGNALS IS INCLUDED IN THE COST FOR TEMPORARY TRAFFIC SIGNAL INSTALLATION.

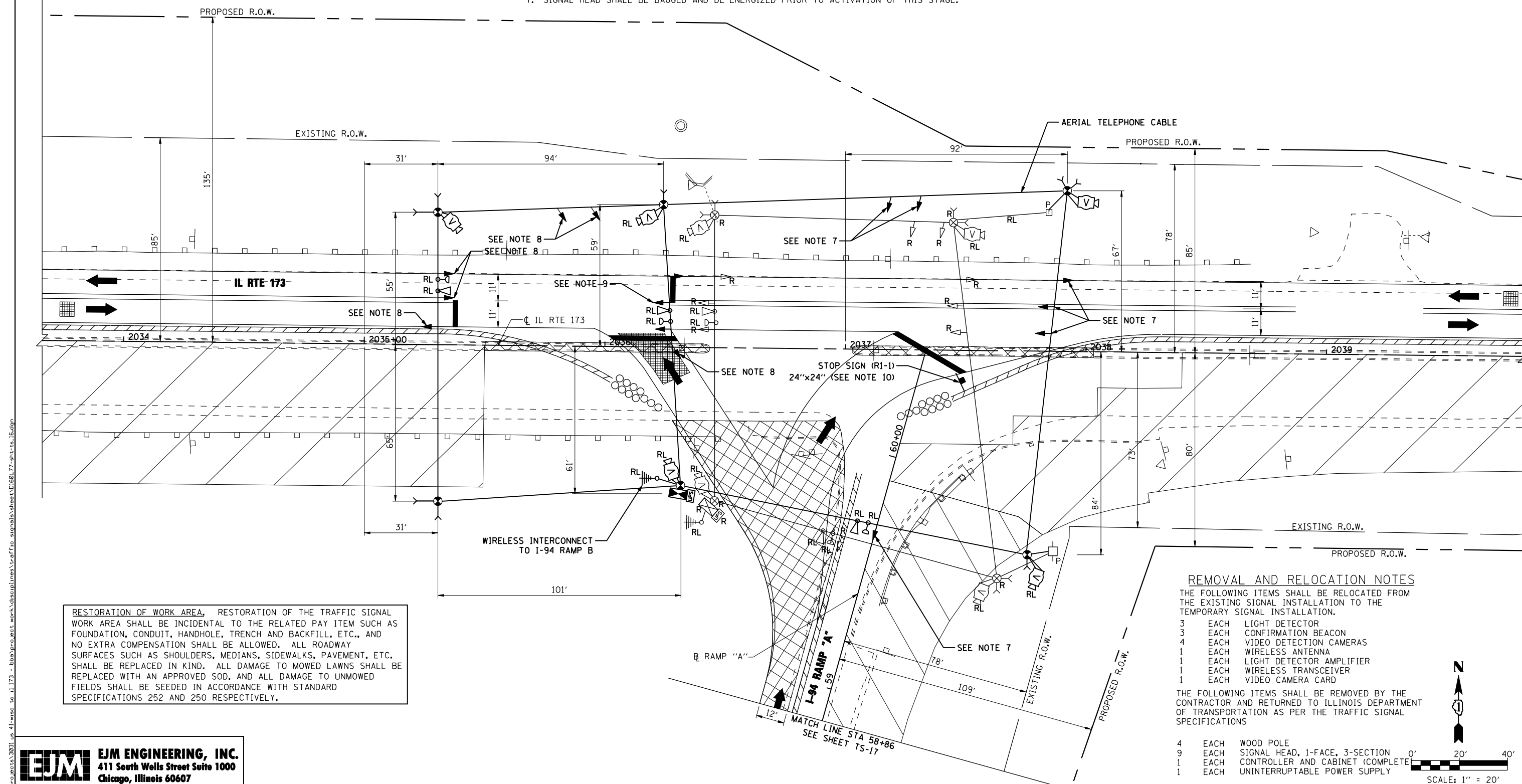

RESTORATION OF WORK AREA. RESTORATION OF THE TRAFFIC SIGNAL WORK AREA SHALL BE INCIDENTAL TO THE RELATED PAY ITEM SUCH AS FOUNDATION, CONDUIT, HANDHOLE, TRENCH AND BACKFILL, ETC., AND NO EXTRA COMPENSATION SHALL BE ALLOWED. ALL ROADWAY SURFACES SUCH AS SHOULDERS, MEDIANS, SIDEWALKS, PAVEMENT, ETC. SHALL BE REPLACED IN KIND. ALL DAMAGE TO MOWED LAWNS SHALL BE REPLACED WITH AN APPROVED SOD, AND ALL DAMAGE TO UNMOWED FIELDS SHALL BE SEEDED IN ACCORDANCE WITH STANDARD SPECIFICATIONS 252 AND 250 RESPECTIVELY.

REMOVAL AND RELOCATION NOTES

THE FOLLOWING ITEMS SHALL BE RELOCATED FROM THE EXISTING SIGNAL INSTALLATION TO THE TEMPORARY SIGNAL INSTALLATION.

- 3 EACH LIGHT DETECTOR
- 3 EACH CONFIRMATION BEACON
- 4 EACH VIDEO DETECTION CAMERAS
- 1 EACH WIRELESS ANTENNA
- 1 EACH LIGHT DETECTOR AMPLIFIER
- 1 EACH WIRELESS TRANSCIEIVER
- 1 EACH VIDEO CAMERA CARD

THE FOLLOWING ITEMS SHALL BE REMOVED BY THE CONTRACTOR AND RETURNED TO ILLINOIS DEPARTMENT OF TRANSPORTATION AS PER THE TRAFFIC SIGNAL SPECIFICATIONS

- 4 EACH WOOD POLE
- 9 EACH SIGNAL HEAD, 1-FACE, 3-SECTION
- 1 EACH CONTROLLER AND CABINET (COMPLETE)
- 1 EACH UNINTERRUPTABLE POWER SUPPLY

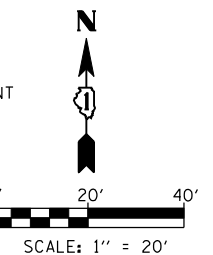

EJM ENGINEERING, INC.
411 South Wells Street Suite 1000
Chicago, Illinois 60607

FILE NAME =	USER NAME = gra1	DESIGNED - GR	REVISED -
		DRAWN - GR	REVISED -
		CHECKED - BKS	REVISED -
		DATE - 06/19/2012	REVISED -

**STATE OF ILLINOIS
DEPARTMENT OF TRANSPORTATION**

**TEMPORARY TRAFFIC SIGNAL INSTALLATION
IL RTE 173 AT I-94 RAMP "A" - STAGE 1A**

SCALE: 1" = 20' SHEET NO. 1 OF 2 SHEETS STA. 2033+67 TO STA. 2039+83

F.A.I. RTE.	SECTION	COUNTY	TOTAL SHEETS	SHEET NO.
94	49-1-R-1	LAKE	677	347
ILLINOIS FED. AID PROJECT			CONTRACT NO. 60L77	

TS-16

NOTES:

1. VIDEO DETECTION ZONES SHALL BE PROGRAMMED IN THE FIELD BY THE CONTRACTOR AND APPROVED BY THE ENGINEER.

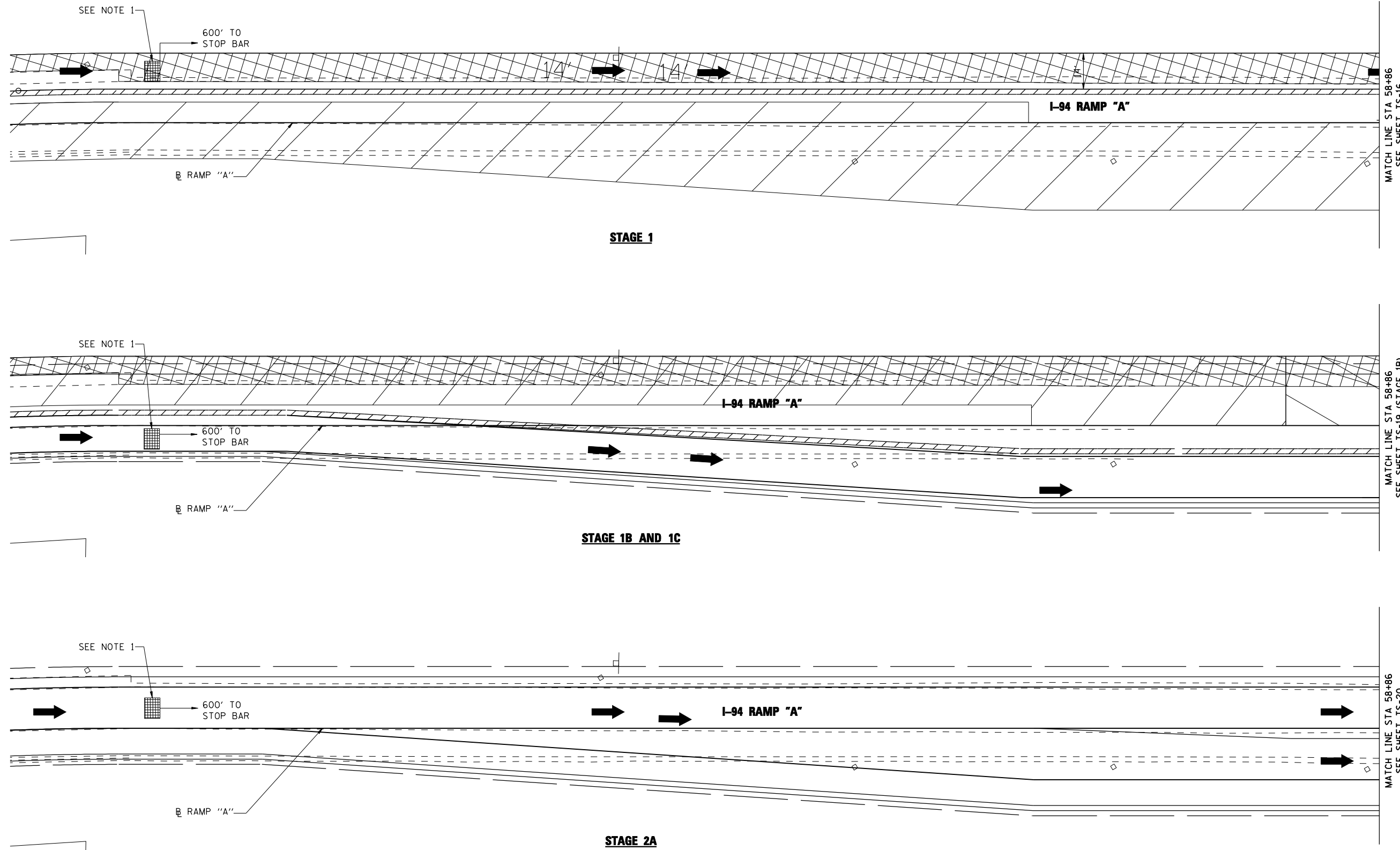

s:\projects\3021.us_41-usa_to_11.173 - bba\p\sect_work\displines\tr-offic_signals\shes\01606L77-sh1-ts-17.dgn

EJM ENGINEERING, INC.
 411 South Wells Street Suite 1000
 Chicago, Illinois 60607

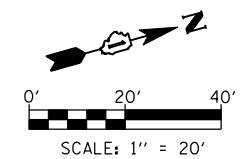

FILE NAME =	USER NAME = gra1	DESIGNED - GR	REVISED -
		DRAWN - GR	REVISED -
	PLOT SCALE = 40,0000' / IN.	CHECKED - BKS	REVISED -
	PLOT DATE = 6/18/2012	DATE - 06/19/2012	REVISED -

**STATE OF ILLINOIS
 DEPARTMENT OF TRANSPORTATION**

**TEMPORARY TRAFFIC SIGNAL INSTALLATION
 IL RTE 173 AT I-94 RAMP "A" - STAGE 1A, 1B, AND 2A**

SCALE: 1" = 20' SHEET NO. 2 OF 2 SHEETS STA. 321+95 TO STA. 327+01

F.A.I. RTE.	SECTION	COUNTY	TOTAL SHEETS	SHEET NO.
94	49-1-R-1	LAKE	677	348
CONTRACT NO.			60L77	
ILLINOIS FED. AID PROJECT				

TS-17

CONTROLLER SEQUENCE

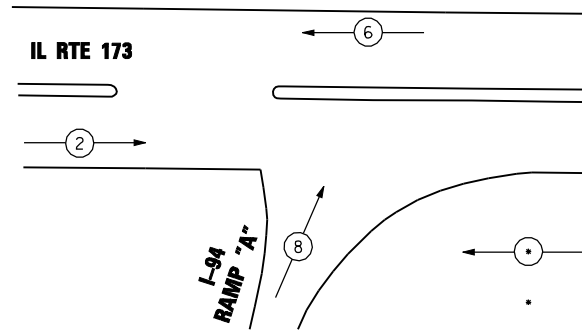

LEGEND
 DUAL ENTRY PHASE
 NUMBER REFERS TO ASSOCIATED PHASE

PHASE DESIGNATION DIAGRAM

EMERGENCY VEHICLE PREEMPTION SEQUENCE

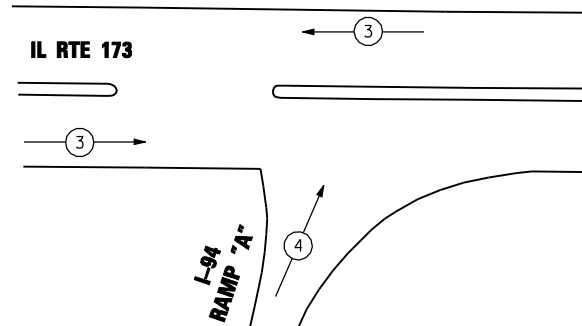

PROPOSED EMERGENCY VEHICLE PREEMPTORS		
EMERGENCY VEHICLE PREEMPTOR	3	4
MOVEMENT	←	↑

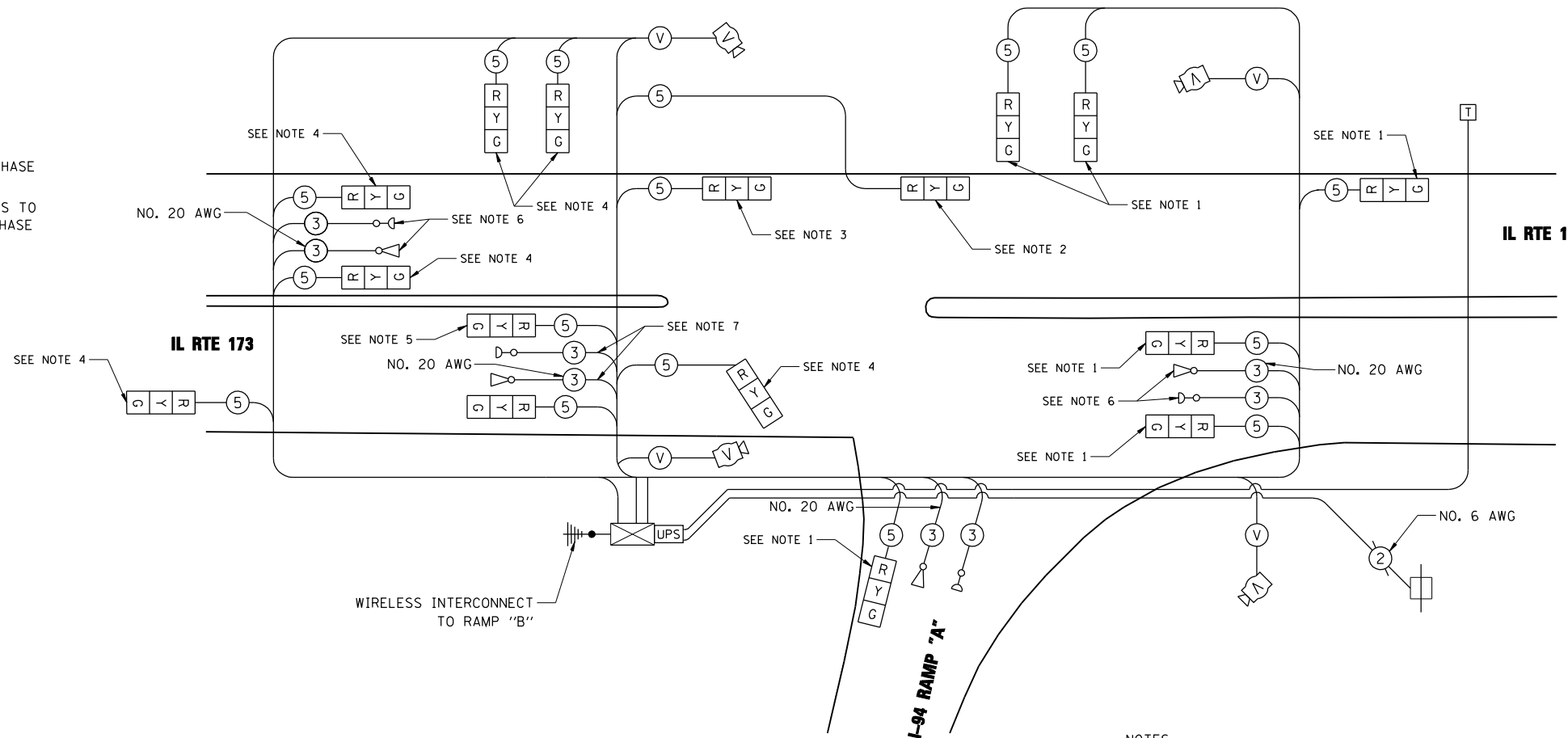

CABLE PLAN

CABLE PLAN

NOTES:

- SIGNAL HEAD SHALL BE BAGGED AND DE-ENERGIZED DURING STAGES 1A AND 1C. SIGNAL HEAD SHALL BE ACTIVATED DURING STAGES 1B AND 2A.
- SIGNAL HEAD SHALL BE INSTALLED AND ACTIVATED FOR STAGE 1C ONLY. SIGNAL HEAD SHALL BE REMOVED UPON COMPLETION OF STAGE 1C.
- SIGNAL HEAD SHALL BE BAGGED AND DE-ENERGIZED DURING STAGE 1C. SIGNAL HEAD SHALL BE ACTIVATED DURING STAGES 1A, 1B AND 2A.
- SIGNAL HEAD SHALL BE BAGGED AND DE-ENERGIZED DURING STAGES 1B AND 2A. SIGNAL HEAD SHALL BE ACTIVATED DURING STAGES 1A AND 1C.
- SIGNAL HEAD SHALL BE ROTATED TO FACE EASTBOUND TRAFFIC DURING STAGES 1A AND 1C. SIGNAL HEAD SHALL BE ROTATED TO FACE WESTBOUND TRAFFIC DURING STAGES 1B AND 2A.
- EMERGENCY VEHICLE PREEMPTION EQUIPMENT RELOCATED BETWEEN STAGES 1A, 1B, 1C, AND 2A.
- EMERGENCY VEHICLE PREEMPTION DETECTOR AND CONFIRMATION BEACON SHALL BE ROTATED TO FACE EASTBOUND TRAFFIC DURING STAGES 1A AND 1C. EMERGENCY VEHICLE PREEMPTION DETECTOR AND CONFIRMATION BEACON SHALL BE ROTATED TO FACE WESTBOUND TRAFFIC DURING STAGES 1B AND 2A.
- THE EMERGENCY VEHICLE PREEMPTION EQUIPMENT FOR THIS INTERSECTION SHALL BE "OPTICOM" TO MATCH THE TOWNSHIP SYSTEM.

RESTORATION OF WORK AREA, RESTORATION OF THE TRAFFIC SIGNAL WORK AREA SHALL BE INCIDENTAL TO THE RELATED PAY ITEM SUCH AS FOUNDATION, CONDUIT, HANDHOLE, TRENCH AND BACKFILL, ETC., AND NO EXTRA COMPENSATION SHALL BE ALLOWED. ALL ROADWAY SURFACES SUCH AS SHOULDERS, MEDIANS, SIDEWALKS, PAVEMENT, ETC. SHALL BE REPLACED IN KIND. ALL DAMAGE TO MOWED LAWNS SHALL BE REPLACED WITH AN APPROVED SOD, AND ALL DAMAGE TO UNMOWED FIELDS SHALL BE SEEDED IN ACCORDANCE WITH STANDARD SPECIFICATIONS 252 AND 250 RESPECTIVELY.

I.D.O.T.
 TRAFFIC SIGNAL INSTALLATION
 ELECTRICAL SERVICE REQUIREMENTS

TYPE	NO. OF LAMPS	WATTAGE		% OPERATIONS	TOTAL WATTAGE
		INCAND.	LED		
SIGNAL (RED)	9	135	17	0.50	76.5
(YELLOW)	9	135	25	0.25	56.25
(GREEN)	9	135	15	0.25	33.75
ARROW	-	135	12	0.10	-
PED. SIGNAL	-	90	25	1.00	-
CONTROLLER	1	100	100	1.00	100
ILLUM. SIGN			25	0.50	

ENERGY COSTS TO: TOTAL = 266.5

ILLINOIS DEPARTMENT OF TRANSPORTATION

DIVISION OF HIGHWAYS/DISTRICT 1
 201 WEST CENTER COURT/SCHAUMBURG, IL 60196

ENERGY SUPPLY: CONTACT: DOROTHY PROSEN
 PHONE: (847) 816-5323
 COMPANY: COM ED

EJM ENGINEERING, INC.
 411 South Wells Street Suite 1000
 Chicago, Illinois 60607

FILE NAME =	USER NAME = gra1	DESIGNED - GR	REVISED -
		DRAWN - GR	REVISED -
	PLOT SCALE = none	CHECKED - BKS	REVISED -
	PLOT DATE = 6/18/2012	DATE - 06/19/2012	REVISED -

STATE OF ILLINOIS
 DEPARTMENT OF TRANSPORTATION

TEMPORARY CABLE PLAN, TEMPORARY PHASE DESIGNATION DIAGRAM,
 AND TEMPORARY EMERGENCY VEHICLE PREEMPTION SEQUENCE
 IL RTE 173 AT I-94 RAMP "A"

SCALE: NONE SHEET NO. 1 OF 1 SHEETS STA. TO STA.

F.A.I. RTE. 94	SECTION 49-1-R-1	COUNTY LAKE	TOTAL SHEETS 677	SHEET NO. 349
ILLINOIS FED. AID PROJECT			CONTRACT NO. 60L77	

TS-18

NOTES:

1. SIGNAL HEAD SHALL BE BAGGED AND DE-ENERGIZED PRIOR TO ACTIVATION OF THIS STAGE.
2. SIGNAL HEAD SHALL BE BAGGED AND DE-ENERGIZED AT THE END OF THIS STAGE, PRIOR TO BEGINNING OF STAGE 1C.
3. SIGNAL HEAD SHALL BE ROTATED TO FACE WESTBOUND TRAFFIC DURING THIS STAGE. AT THE END OF THIS STAGE AND PRIOR TO BEGINNING OF STAGE 1C, SIGNAL HEAD SHALL BE ROTATED TO FACE EASTBOUND TRAFFIC.
4. TEMPORARY SIGN AND MOUNTING IS INCIDENTAL TO THE COST OF TEMPORARY SIGNAL INSTALLATION.

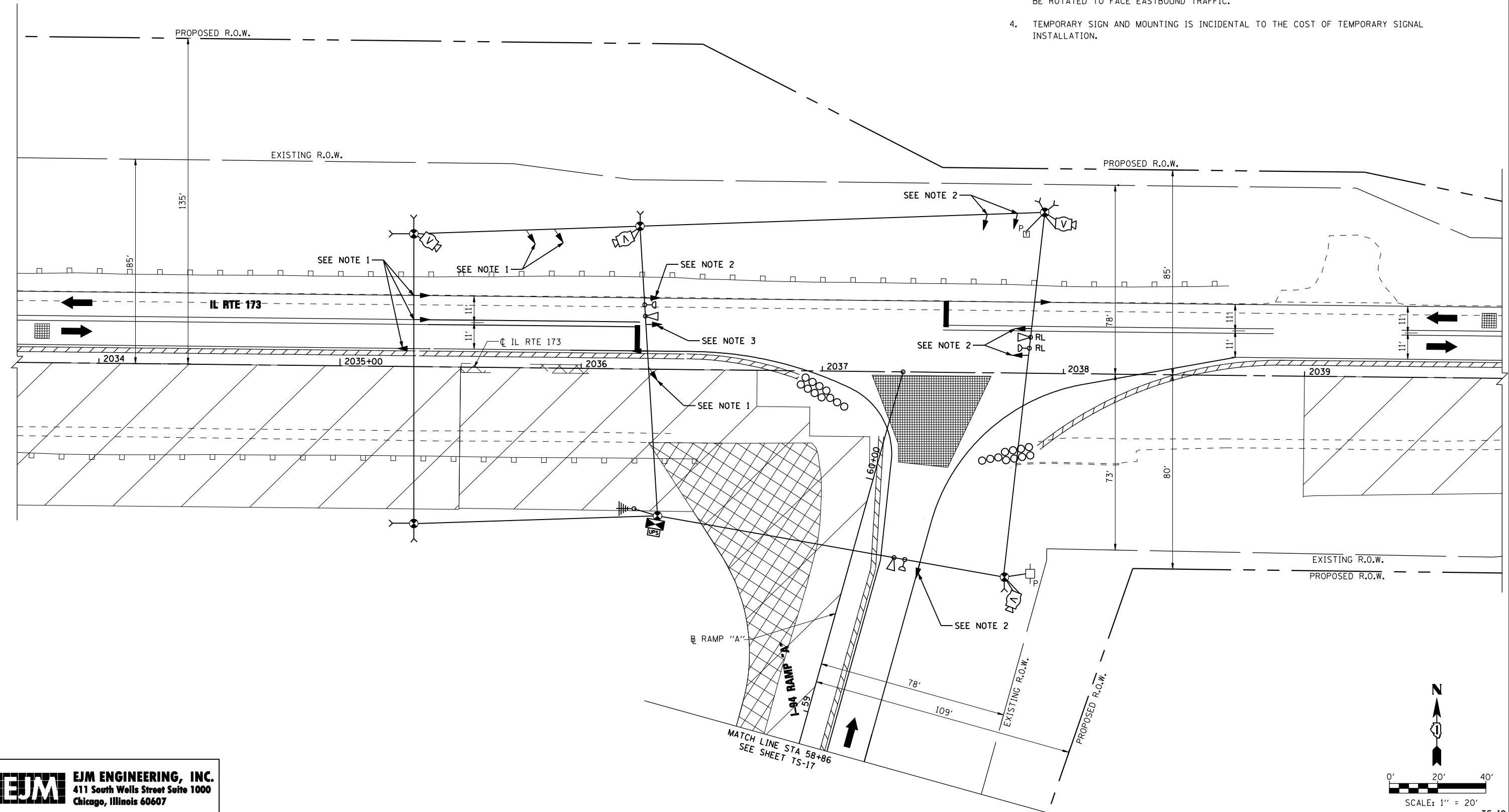

s:\projects\3021.us_41-usa_to_11.173 - bba\proj\sect_work\disuplines\tr-offic_signals\sheet\01606L77-sh1-ts_19.dgn

EJM ENGINEERING, INC.
 411 South Wells Street Suite 1000
 Chicago, Illinois 60607

FILE NAME =	USER NAME = grai	DESIGNED - GR	REVISED -
		DRAWN - GR	REVISED -
	PLOT SCALE = 40,0000' / IN.	CHECKED - BKS	REVISED -
	PLOT DATE = 6/18/2012	DATE - 06/19/2012	REVISED -

**STATE OF ILLINOIS
 DEPARTMENT OF TRANSPORTATION**

**TEMPORARY TRAFFIC SIGNAL INSTALLATION
 IL RTE 173 AT I-94 RAMP "A" - STAGE 1B**

SCALE: 1" = 20' SHEET NO. 1 OF 2 SHEETS STA. 2033+67 TO STA. 2039+83

F.A.I. RTE.	SECTION	COUNTY	TOTAL SHEETS	SHEET NO.
94	49-1-R-1	LAKE	677	350
CONTRACT NO. 60L77			ILLINOIS FED. AID PROJECT	

TS-19

NOTES:

1. SIGNAL HEAD SHALL BE BAGGED AND DE-ENERGIZED PRIOR TO ACTIVATION OF THIS STAGE.
2. SIGNAL HEAD SHALL BE BAGGED AND DE-ENERGIZED AT THE END OF THIS STAGE, PRIOR TO BEGINNING OF STAGE 2A.
3. SIGNAL HEAD SHALL BE ROTATED TO FACE EASTBOUND TRAFFIC DURING THIS STAGE. AT THE END OF THIS STAGE AND PRIOR TO BEGINNING OF STAGE 1C, SIGNAL HEAD SHALL BE ROTATED TO FACE WESTBOUND TRAFFIC.
4. TEMPORARY SIGN AND MOUNTING IS INCIDENTAL TO THE COST OF TEMPORARY SIGNAL INSTALLATION.
5. INSTALL TEMPORARY WOOD POLE, SIGNAL HEAD, SPAN WIRE, CABLE AND ALL APPURTENANCES PRIOR TO ACTIVATION OF STAGE 1C. INSTALL "STOP HERE ON RED" SIGN R10-6 (24"x36") ON WOOD POLE. AT THE END OF THIS STAGE, PRIOR TO ACTIVATION OF STAGE 2A, REMOVE THE SIGNAL HEAD AND SIGN PANEL. REMOVE WOOD POLE, SPAN WIRE AND CABLE AFTER STAGE 1C. THIS WORK, INCLUDING ALL MATERIAL AND LABOR, SHALL BE INCLUDED IN THE COST OF TEMPORARY SIGNAL INSTALLATION

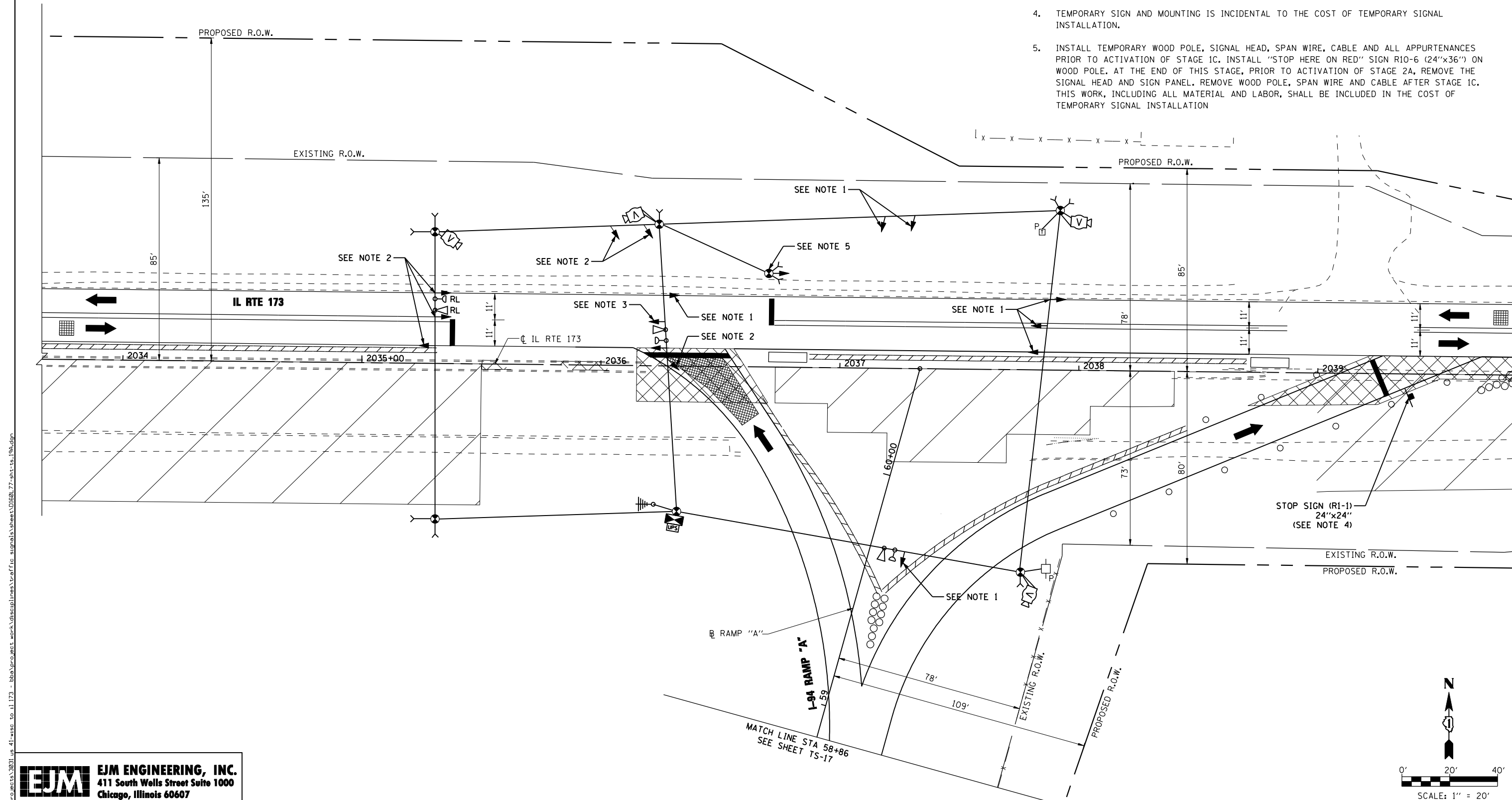

s:\projects\3021.us_41-usa_to_il_173 - bba\proj\sect_work\disuplines\tr-offic_signals\sheet\0160L77-sh1-ts_19a.dgn

EJM ENGINEERING, INC.
 411 South Wells Street Suite 1000
 Chicago, Illinois 60607

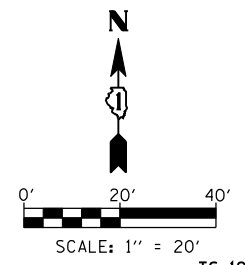

FILE NAME =	USER NAME = grai	DESIGNED - GR	REVISED -
		DRAWN - GR	REVISED -
	PLOT SCALE = 40,0000' / IN.	CHECKED - BKS	REVISED -
	PLOT DATE = 6/18/2012	DATE - 06/19/2012	REVISED -

**STATE OF ILLINOIS
 DEPARTMENT OF TRANSPORTATION**

**TEMPORARY TRAFFIC SIGNAL INSTALLATION
 IL RTE 173 AT I-94 RAMP "A" - STAGE 1C**

SCALE: 1" = 20' SHEET NO. 1 OF 2 SHEETS STA. 2033+67 TO STA. 2039+83

F.A.I. RTE.	SECTION	COUNTY	TOTAL SHEETS	SHEET NO.
94	49-1-R-1	LAKE	677	350A
CONTRACT NO. 60L77			ILLINOIS FED. AID PROJECT	

TS-19A

NOTES:

1. SIGNAL HEAD SHALL BE BAGGED AND DE-ENERGIZED PRIOR TO ACTIVATION OF THIS STAGE.
2. SIGNAL HEAD SHALL BE ROTATED TO FACE WESTBOUND TRAFFIC DURING THIS STAGE.
3. TEMPORARY SIGN AND MOUNTING IS INCIDENTAL TO THE COST OF TEMPORARY SIGNAL INSTALLATION.

REMOVAL AND RELOCATION NOTES

THE FOLLOWING ITEMS SHALL BE RELOCATED TO THE PERMANENT SIGNAL INSTALLATION UPON COMPLETION OF STAGE 2A AND PRIOR TO ACTIVATION OF PERMANENT SIGNAL OPERATIONS.

- 3 EACH LIGHT DETECTOR
- 1 EACH LIGHT DETECTOR AMPLIFIER
- 3 EACH CONFIRMATION BEACON

THE FOLLOWING ITEMS SHALL BE REMOVED BY THE CONTRACTOR AND SHALL REMAIN THE PROPERTY OF THE AGENCY LISTED BELOW. THE CONTRACTOR SHALL SAFELY STORE AND ARRANGE FOR PICK UP OF ALL EQUIPMENT TO BE RETURNED TO THE LISTED AGENCY AS PER THE TRAFFIC SIGNAL SPECIFICATIONS

AGENCY: ILLINOIS DEPARTMENT OF TRANSPORTATION

- 4 EACH VIDEO DETECTION CAMERAS
- 1 EACH VIDEO CAMERA CARD

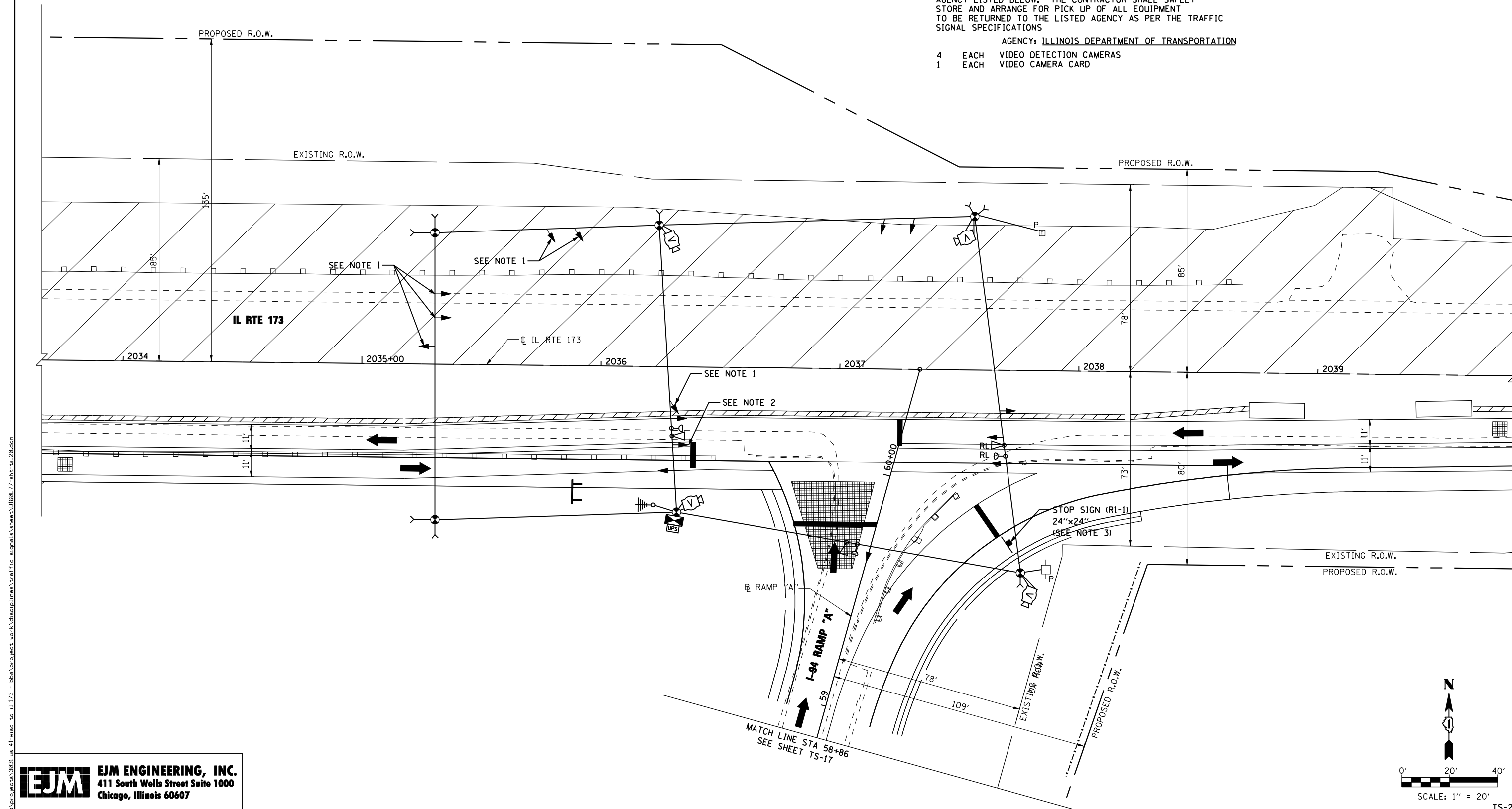

s:\projects\3021.us_41-usa_to_il_173 - bba\proj\sect_work\disuplines\tr-offic_signals\sheet\60L77-sht-ts-20.dgn

EJM ENGINEERING, INC.
 411 South Wells Street Suite 1000
 Chicago, Illinois 60607

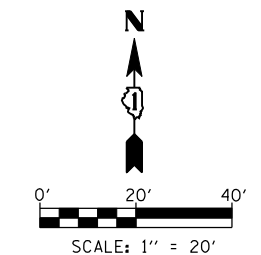

FILE NAME =	USER NAME = grai	DESIGNED - GR	REVISED -
		DRAWN - GR	REVISED -
	PLOT SCALE = 40,0000' / IN.	CHECKED - BKS	REVISED -
	PLOT DATE = 6/18/2012	DATE - 06/19/2012	REVISED -

**STATE OF ILLINOIS
 DEPARTMENT OF TRANSPORTATION**

**TEMPORARY TRAFFIC SIGNAL INSTALLATION
 IL RTE 173 AT I-94 RAMP "A" - STAGE 2A**
 SCALE: 1" = 20' SHEET NO. 1 OF 2 SHEETS STA. 2033+67 TO STA. 2039+83

F.A.I. RTE.	SECTION	COUNTY	TOTAL SHEETS	SHEET NO.
94	49-1-R-1	LAKE	677	351
CONTRACT NO. 60L77			ILLINOIS FED. AID PROJECT	

TS-20

RESTORATION OF WORK AREA, RESTORATION OF THE TRAFFIC SIGNAL WORK AREA SHALL BE INCIDENTAL TO THE RELATED PAY ITEM SUCH AS FOUNDATION, CONDUIT, HANDHOLE, TRENCH AND BACKFILL, ETC., AND NO EXTRA COMPENSATION SHALL BE ALLOWED. ALL ROADWAY SURFACES SUCH AS SHOULDERS, MEDIANS, SIDEWALKS, PAVEMENT, ETC. SHALL BE REPLACED IN KIND. ALL DAMAGE TO MOWED LAWNS SHALL BE REPLACED WITH AN APPROVED SOD, AND ALL DAMAGE TO UNMOWED FIELDS SHALL BE SEEDED IN ACCORDANCE WITH STANDARD SPECIFICATIONS 252 AND 250 RESPECTIVELY.

NOTES:

- EMERGENCY VEHICLE PREEMPTION EQUIPMENT SHALL BE RELOCATED FROM THE TEMPORARY SIGNAL INSTALLATION.

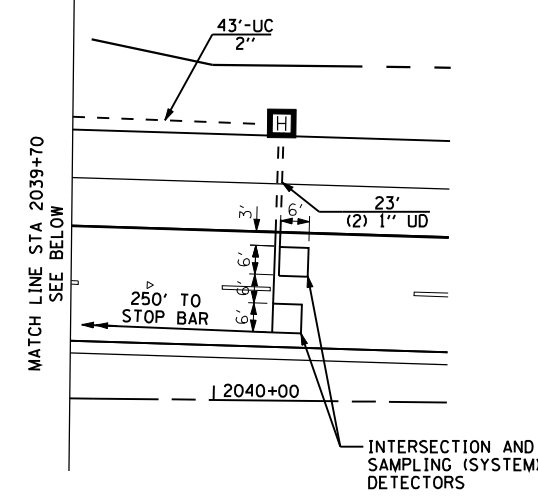
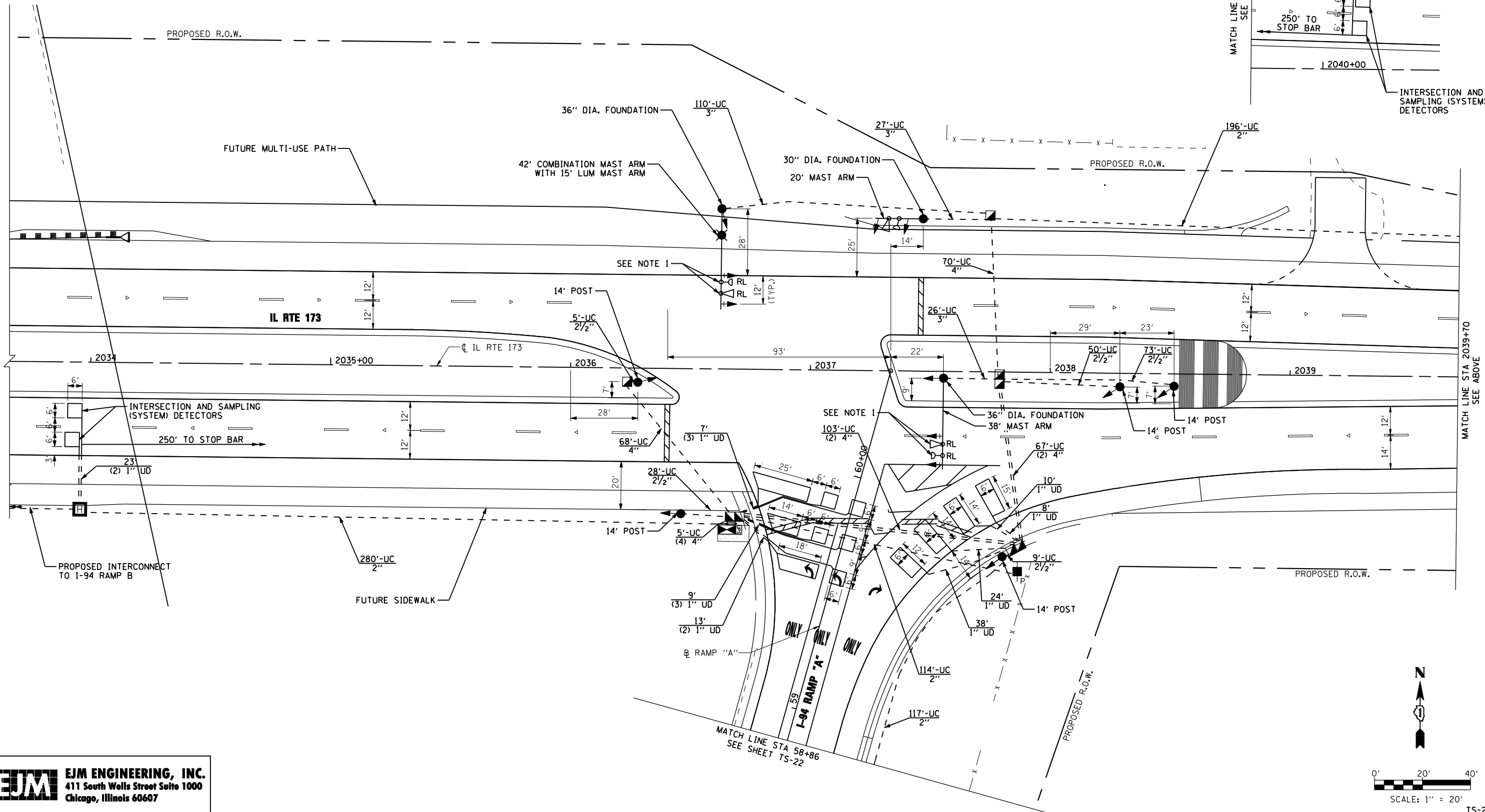

s:\projects\3021.us_41-usa.to.il.173 - bba\p\sect\work\disup\lines\tr-offic_signals\sheet\60L77-sht-ts-21.dgn

EJM ENGINEERING, INC.
411 South Wells Street Suite 1000
Chicago, Illinois 60607

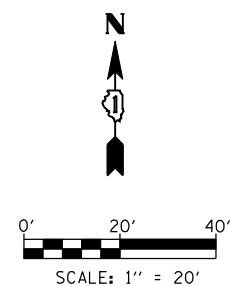

FILE NAME =	USER NAME = grai	DESIGNED - GR	REVISED -
		DRAWN - GR	REVISED -
	PLOT SCALE = 40,0000' / IN.	CHECKED - BKS	REVISED -
	PLOT DATE = 6/18/2012	DATE - 06/19/2012	REVISED -

**STATE OF ILLINOIS
DEPARTMENT OF TRANSPORTATION**

**TRAFFIC SIGNAL INSTALLATION
IL RTE 173 AT I-94 RAMP "A"**

SCALE: 1" = 20' SHEET NO. 1 OF 2 SHEETS STA. 2033+67 TO STA. 2039+83

F.A.I. RTE.	SECTION	COUNTY	TOTAL SHEETS	SHEET NO.
94	49-1-R-1	LAKE	677	352
CONTRACT NO. 60L77			ILLINOIS FED. AID PROJECT	

TS-21

RESTORATION OF WORK AREA, RESTORATION OF THE TRAFFIC SIGNAL WORK AREA SHALL BE INCIDENTAL TO THE RELATED PAY ITEM SUCH AS FOUNDATION, CONDUIT, HANDHOLE, TRENCH AND BACKFILL, ETC., AND NO EXTRA COMPENSATION SHALL BE ALLOWED. ALL ROADWAY SURFACES SUCH AS SHOULDERS, MEDIANS, SIDEWALKS, PAVEMENT, ETC. SHALL BE REPLACED IN KIND. ALL DAMAGE TO MOWED LAWNS SHALL BE REPLACED WITH AN APPROVED SOD, AND ALL DAMAGE TO UNMOWED FIELDS SHALL BE SEEDED IN ACCORDANCE WITH STANDARD SPECIFICATIONS 252 AND 250 RESPECTIVELY.

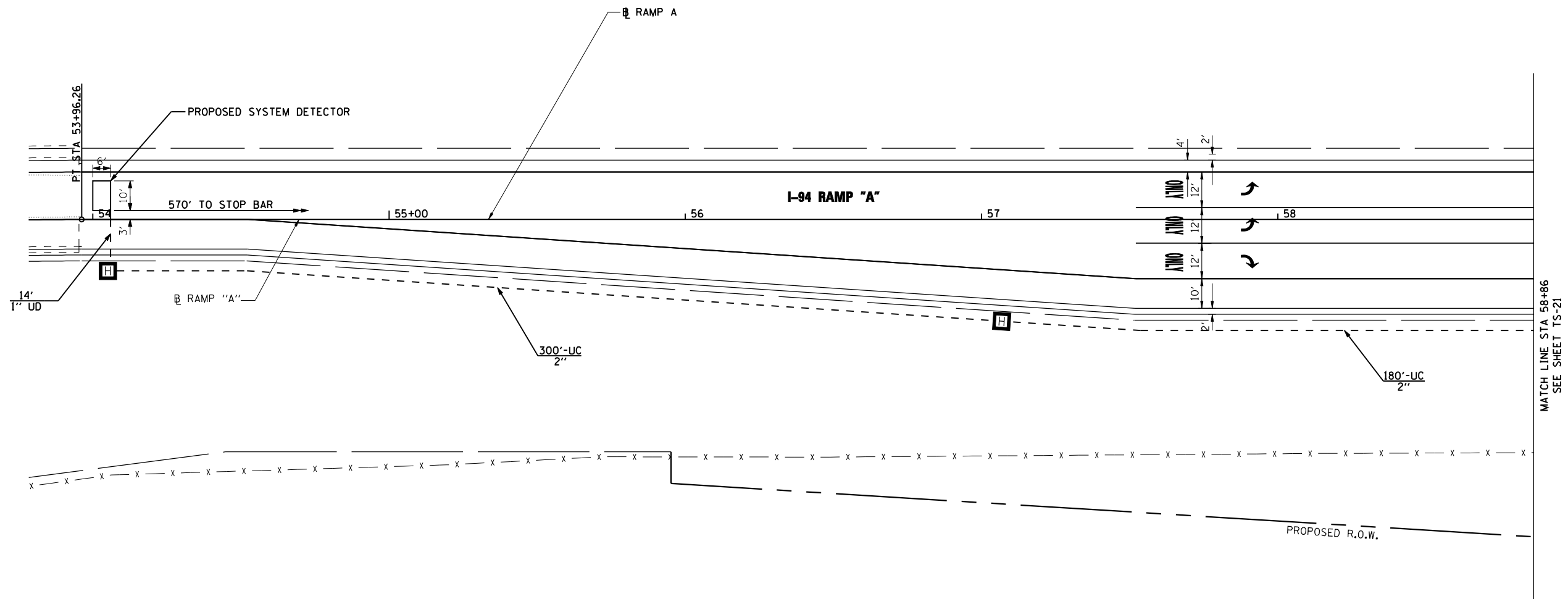

s:\projects\3021.us_41-usa.to.il.173 - bba\project\work\disiplines\traffic_signals\sheet\ts-22.dgn

EJM **EJM ENGINEERING, INC.**
 411 South Wells Street Suite 1000
 Chicago, Illinois 60607



FILE NAME =	USER NAME = grai	DESIGNED - GR	REVISED -
		DRAWN - GR	REVISED -
	PLOT SCALE = 40,0000 ' / IN.	CHECKED - BKS	REVISED -
	PLOT DATE = 6/18/2012	DATE - 06/19/2012	REVISED -

STATE OF ILLINOIS
DEPARTMENT OF TRANSPORTATION

TRAFFIC SIGNAL INSTALLATION
IL RTE 173 AT I-94 RAMP "A"

SCALE: 1" = 20' SHEET NO. 2 OF 2 SHEETS STA. 321+95 TO STA. 327+01

F.A.I. RTE.	SECTION	COUNTY	TOTAL SHEETS	SHEET NO.
94	49-1-R-1	LAKE	677	353
CONTRACT NO.			60L77	
ILLINOIS FED. AID PROJECT				

TS-22

CONTROLLER SEQUENCE

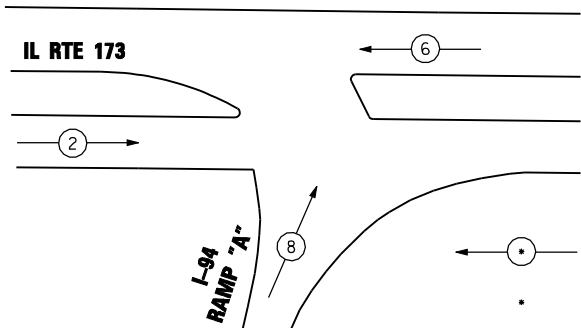

LEGEND

- DUAL ENTRY PHASE
- NUMBER REFERS TO ASSOCIATED PHASE

PHASE DESIGNATION DIAGRAM

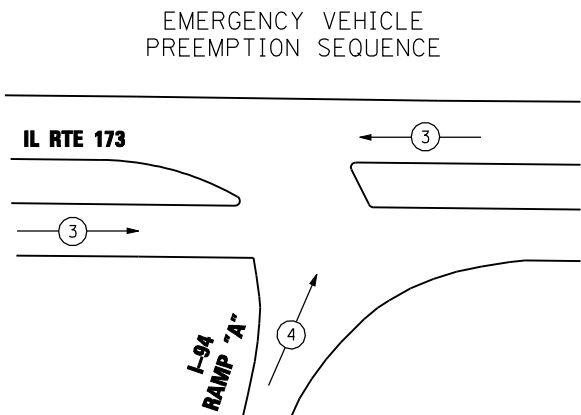

PROPOSED EMERGENCY VEHICLE PREEMPTORS		
EMERGENCY VEHICLE PREEMPTOR	3	4
MOVEMENT	←	↑

I.D.O.T. TRAFFIC SIGNAL INSTALLATION ELECTRICAL SERVICE REQUIREMENTS

TYPE	NO. OF LAMPS	WATTAGE		% OPERATIONS	TOTAL WATTAGE
		INCAND.	LED		
SIGNAL (RED)	12	135	17	0.50	102
(YELLOW)	12	135	25	0.25	75
(GREEN)	12	135	15	0.25	45
ARROW	-	135	12	0.10	-
PED. SIGNAL	-	90	25	1.00	-
CONTROLLER	1	100	100	1.00	100
ILLUM. SIGN	-	-	25	0.50	-

ENERGY COSTS TO: TOTAL = 322.0

ILLINOIS DEPARTMENT OF TRANSPORTATION

DIVISION OF HIGHWAYS/DISTRICT 1
201 WEST CENTER COURT/SCHAUMBURG, IL 60196

ENERGY SUPPLY: CONTACT: DOROTHY PROSEN
PHONE: (847) 816-5323
COMPANY: COM ED

SCHEDULE OF QUANTITIES

CODE NUMBER	ITEM	UNIT	TOTAL
72000200	SIGN PANEL - TYPE 2	SQ FT	16.25
80500020	SERVICE INSTALLATION - POLE MOUNTED	EACH	1
81028200	UNDERGROUND CONDUIT, GALVANIZED STEEL, 2" DIA.	FOOT	1230
81028210	UNDERGROUND CONDUIT, GALVANIZED STEEL, 2 1/2" DIA.	FOOT	165
81028220	UNDERGROUND CONDUIT, GALVANIZED STEEL, 3" DIA.	FOOT	163
81028240	UNDERGROUND CONDUIT, GALVANIZED STEEL, 4" DIA.	FOOT	498
81400100	HANDHOLE	EACH	2
81400200	HEAVY-DUTY HANDHOLE	EACH	4
81400300	DOUBLE HANDHOLE	EACH	3
86400100	TRANSCEIVER - FIBER OPTIC	EACH	1
87301225	ELECTRIC CABLE IN CONDUIT, SIGNAL NO. 14 3C	FOOT	1164
87301245	ELECTRIC CABLE IN CONDUIT, SIGNAL NO. 14 5C	FOOT	3950
87301305	ELECTRIC CABLE IN CONDUIT, LEAD-IN, NO. 14 1 PAIR	FOOT	2579
87301805	ELECTRIC CABLE IN CONDUIT, SERVICE, NO. 6 2 C	FOOT	142
87301900	ELECTRIC CABLE IN CONDUIT, EQUIPMENT GROUNDING CONDUCTOR, NO. 6 1C	FOOT	1071
87502480	TRAFFIC SIGNAL POST, GALVANIZED STEEL 14 FT.	EACH	5
87700140	STEEL MAST ARM ASSEMBLY AND POLE, 20 FT.	EACH	1
87700230	STEEL MAST ARM ASSEMBLY AND POLE, 38 FT.	EACH	1
87702940	STEEL COMBINATION MAST ARM ASSEMBLY AND POLE 42 FT.	EACH	1
87800100	CONCRETE FOUNDATION, TYPE A	FOOT	20
87800150	CONCRETE FOUNDATION, TYPE C	FOOT	4
87800400	CONCRETE FOUNDATION, TYPE E 30-INCH DIAMETER	FOOT	10
87800415	CONCRETE FOUNDATION, TYPE E 36-INCH DIAMETER	FOOT	24
88030020	SIGNAL HEAD, LED, 1-FACE, 3-SECTION, MAST-ARM MOUNTED	EACH	6
88030050	SIGNAL HEAD, LED, 1-FACE, 3-SECTION, BRACKET MOUNTED	EACH	7
88200210	TRAFFIC SIGNAL BACKPLATE, LOUVERED, ALUMINUM	EACH	6
88500100	INDUCTIVE LOOP DETECTOR	EACH	8
88600700	PREFORMED DETECTOR LOOP	FOOT	771
89000100	TEMPORARY TRAFFIC SIGNAL INSTALLATION	EACH	1
89502375	REMOVE EXISTING TRAFFIC SIGNAL EQUIPMENT	EACH	1
X0324085	EMERGENCY VEHICLE PRIORITY SYSTEM LINE SENSOR CABLE, NO. 20 3/C	FOOT	1130
85700200	FULL-ACTUATED CONTROLLER AND TYPE IV CABINET	EACH	1
X8620200	UNINTERRUPTIBLE POWER SUPPLY, SPECIAL	EACH	1
X8950115	RELOCATE LIGHT DETECTOR	EACH	3
X8950120	RELOCATE LIGHT DETECTOR AMPLIFIER	EACH	1
Z0073510	TEMPORARY TRAFFIC SIGNAL TIMING	EACH	1
	RELOCATE VIDEO VEHICLE DETECTION SYSTEM	EACH	1

EJM EJM ENGINEERING, INC.
411 South Wells Street Suite 1000
Chicago, Illinois 60607

FILE NAME =	USER NAME = gra1	DESIGNED - GR	REVISED -
		DRAWN - GR	REVISED -
	PLOT SCALE = none	CHECKED - BKS	REVISED -
	PLOT DATE = 6/18/2012	DATE - 06/19/2012	REVISED -

STATE OF ILLINOIS
DEPARTMENT OF TRANSPORTATION

SCHEDULE OF QUANTITIES, CABLE PLAN,
AND PHASE DESIGNATION DIAGRAM
IL RTE 173 AT I-94 RAMP "A"

SCALE: NONE SHEET NO. 1 OF 1 SHEETS STA. TO STA.

F.A.I. RTE.	SECTION	COUNTY	TOTAL SHEETS	SHEET NO.
94	49-1-R-1	LAKE	677	354
ILLINOIS FED. AID PROJECT			CONTRACT NO. 60L77	

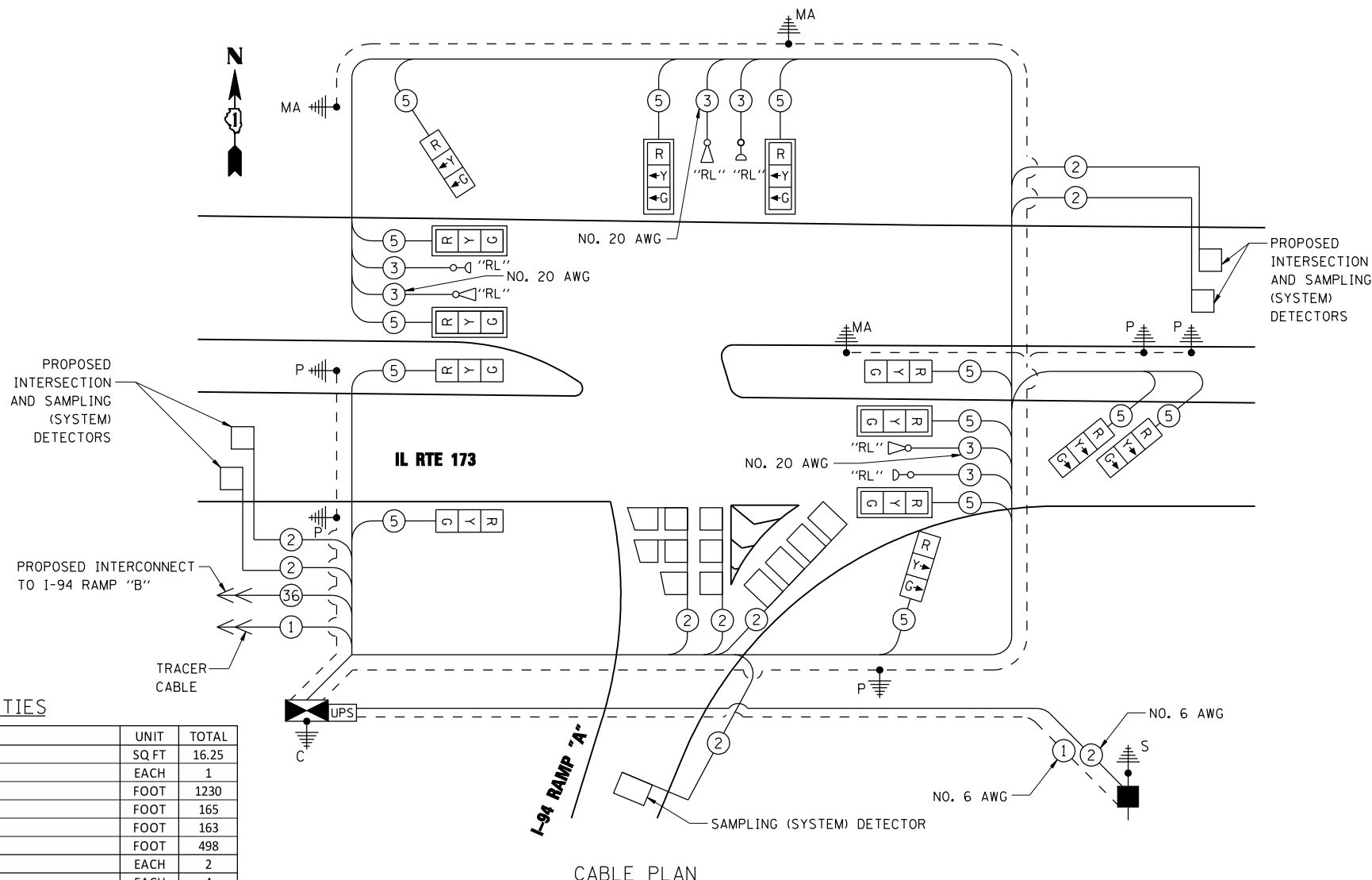

RESTORATION OF WORK AREA, RESTORATION OF THE TRAFFIC SIGNAL WORK AREA SHALL BE INCIDENTAL TO THE RELATED PAY ITEM SUCH AS FOUNDATION, CONDUIT, HANDHOLE, TRENCH AND BACKFILL, ETC., AND NO EXTRA COMPENSATION SHALL BE ALLOWED. ALL ROADWAY SURFACES SUCH AS SHOULDERS, MEDIANS, SIDEWALKS, PAVEMENT, ETC. SHALL BE REPLACED IN KIND. ALL DAMAGE TO MOWED LAWNS SHALL BE REPLACED WITH AN APPROVED SOD, AND ALL DAMAGE TO UNMOWED FIELDS SHALL BE SEEDED IN ACCORDANCE WITH STANDARD SPECIFICATIONS 252 AND 250 RESPECTIVELY.

- NOTES:
- THE EMERGENCY VEHICLE PREEMPTION EQUIPMENT SHALL BE RELOCATED FROM THE TEMPORARY TRAFFIC SIGNAL INSTALLATION.

TS-23

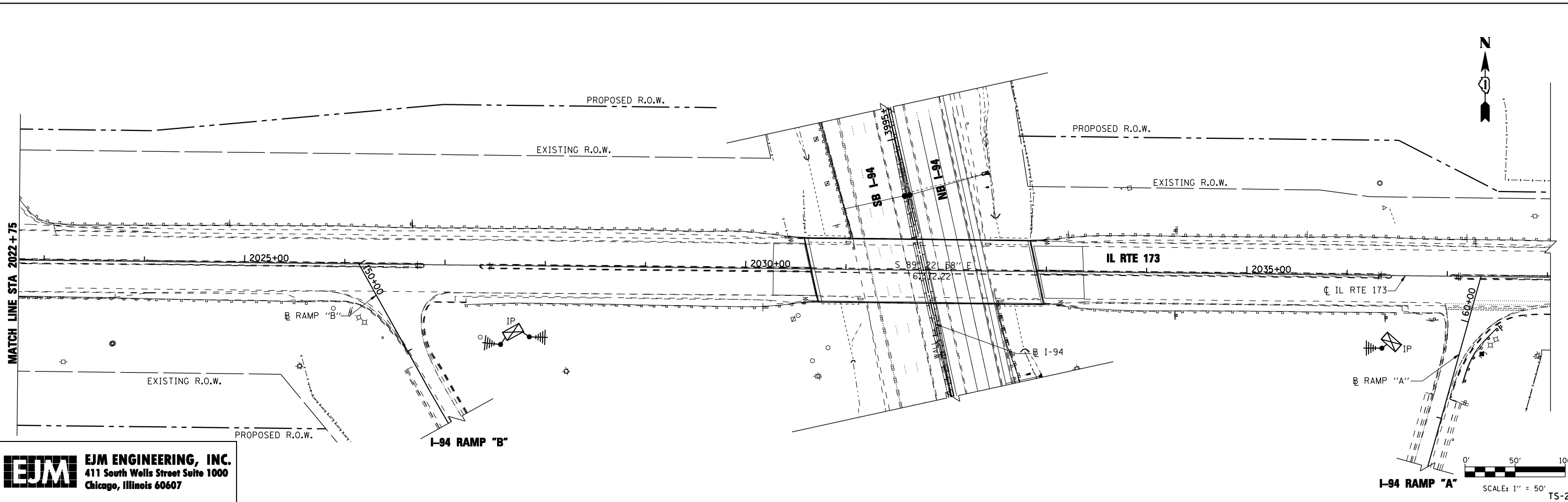
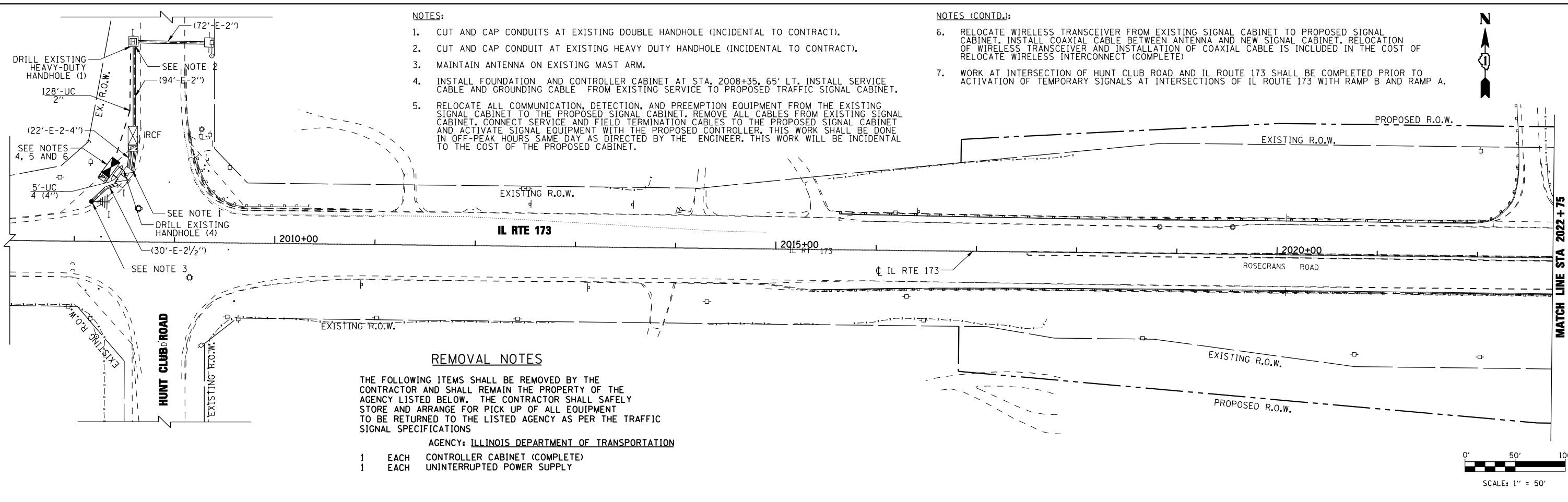

s:\projects\3021.us_41-usa_to_il_173 - bba\p\sect_work\disiplines\tr-offic_signals\sheet\60L77-shr-ts-24.dgn

EJM ENGINEERING, INC.
 411 South Wells Street Suite 1000
 Chicago, Illinois 60607

FILE NAME =	USER NAME = grai	DESIGNED - GR	REVISED -
		DRAWN - GR	REVISED -
	PLOT SCALE = 100.0000' / IN.	CHECKED - BKS	REVISED -
	PLOT DATE = 6/18/2012	DATE - 06/19/2012	REVISED -

**STATE OF ILLINOIS
 DEPARTMENT OF TRANSPORTATION**

**TEMPORARY INTERCONNECT PLAN
 IL RTE 173 - HUNT CLUB ROAD TO I-94 RAMP "A"**

SCALE: 1" = 50' SHEET NO. 1 OF 1 SHEETS STA. 2007+36 TO STA. 2038+03

F.A.I. RTE.	SECTION	COUNTY	TOTAL SHEETS	SHEET NO.
94	49-1-R-1	LAKE	677	355
			CONTRACT NO. 60L77	
ILLINOIS FED. AID PROJECT				

TS-24

IL ROUTE 173 AND HUNT CLUB ROAD
SCHEDULE OF QUANTITIES

CODE NUMBER	ITEM	UNIT	TOTAL
81028200	UNDERGROUND CONDUIT, GALVANIZED STEEL, 2" DIA.	FOOT	128
81028240	UNDERGROUND CONDUIT, GALVANIZED STEEL, 4" DIA.	FOOT	20
85000200	MAINTENANCE OF EXISTING TRAFFIC SIGNAL INSTALLATION	EACH	1
86400100	TRANSCEIVER - FIBER OPTIC	EACH	1
87301805	ELECTRIC CABLE IN CONDUIT, SERVICE, NO. 6 2 C	FOOT	242
87301900	ELECTRIC CABLE IN CONDUIT, EQUIPMENT GROUNDING CONDUCTOR, NO. 6 1C	FOOT	228
87800150	CONCRETE FOUNDATION, TYPE C	FOOT	4
87900200	DRILL EXISTING HANDHOLE	EACH	4
87900205	DRILL EXISTING HEAVY DUTY HANDHOLE	EACH	1
89502300	REMOVE ELECTRIC CABLE FROM CONDUIT	FOOT	250
89502375	REMOVE EXISTING TRAFFIC SIGNAL EQUIPMENT	EACH	1
89502385	REMOVE EXISTING CONCRETE FOUNDATION	EACH	1
85700200	FULL-ACTUATED CONTROLLER AND TYPE IV CABINET	EACH	1
X8620200	UNINTERRUPTABLE POWER SUPPLY, SPECIAL	EACH	1

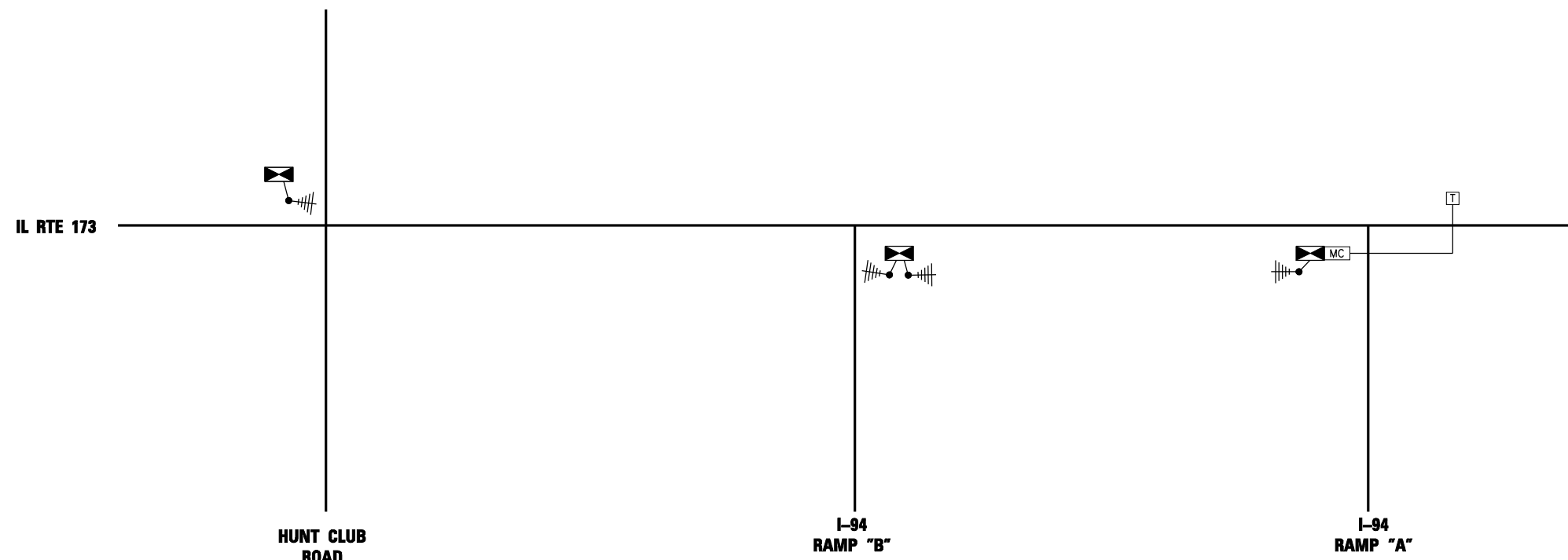

TEMPORARY INTERCONNECT
SCHEDULE OF QUANTITIES

CODE NUMBER	ITEM	UNIT	TOTAL
Z0033056	OPTIMIZE TRAFFIC SIGNAL SYSTEM	EACH	1
	RELOCATE WIRELESS INTERCONNECT (COMPLETE)	L SUM	1

NOTES:

- ALL WIRELESS TRANSCEIVERS, ANTENNAS, AND COAXIAL CABLE REQUIRED TO PLACE THE WIRELESS INTERCONNECT IN SATISFACTORY OPERATION ARE INCLUDED IN THE COST OF THE ITEM "RELOCATE WIRELESS INTERCONNECT (COMPLETE)."
- THE CONTRACTOR SHALL MAINTAIN THE WIRELESS INTERCONNECT AND THE INTERSECTION OF IL RTE 173 AT HUNT CLUB ROAD FOR THE FULL DURATION OF THE CONTRACT. THIS WORK IS INCLUDED IN THE COST OF THE ITEM "MAINTENANCE OF EXISTING TRAFFIC SIGNAL INSTALLATION."
- THE CONTRACTOR IS REQUIRED TO MAINTAIN AND ADJUST CONTROLLER TIMINGS AS DIRECTED BY THE ENGINEER FOR THE FULL DURATION OF THE CONTRACT, WHICH SHALL BE CONSIDERED AS INCLUDED IN THE COST OF "OPTIMIZE TRAFFIC SIGNAL SYSTEM".

c:\projects\3021.us_41-usa_to_il_173 - bba\project\work\disciplines\traffic_signals\sheet\ts_25.dgn



FILE NAME =	USER NAME = grai	DESIGNED - GR	REVISED -
		DRAWN - GR	REVISED -
	PLOT SCALE = none	CHECKED - BKS	REVISED -
	PLOT DATE = 6/18/2012	DATE - 06/19/2012	REVISED -

STATE OF ILLINOIS
DEPARTMENT OF TRANSPORTATION

TEMPORARY INTERCONNECT SCHEMATIC
IL RTE 173 - HUNT CLUB ROAD TO I-94 RAMP "A"

SCALE: NONE SHEET NO. 1 OF 1 SHEETS STA. TO STA.

F.A.I. RTE.	SECTION	COUNTY	TOTAL SHEETS	SHEET NO.
94	49-1-R-1	LAKE	677	356
ILLINOIS FED. AID PROJECT			CONTRACT NO. 60L77	

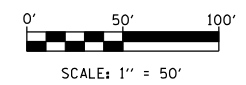
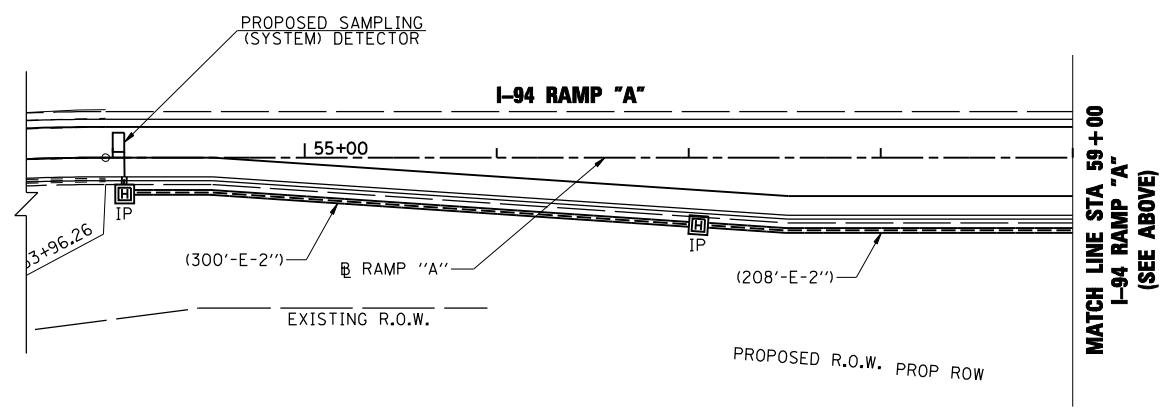
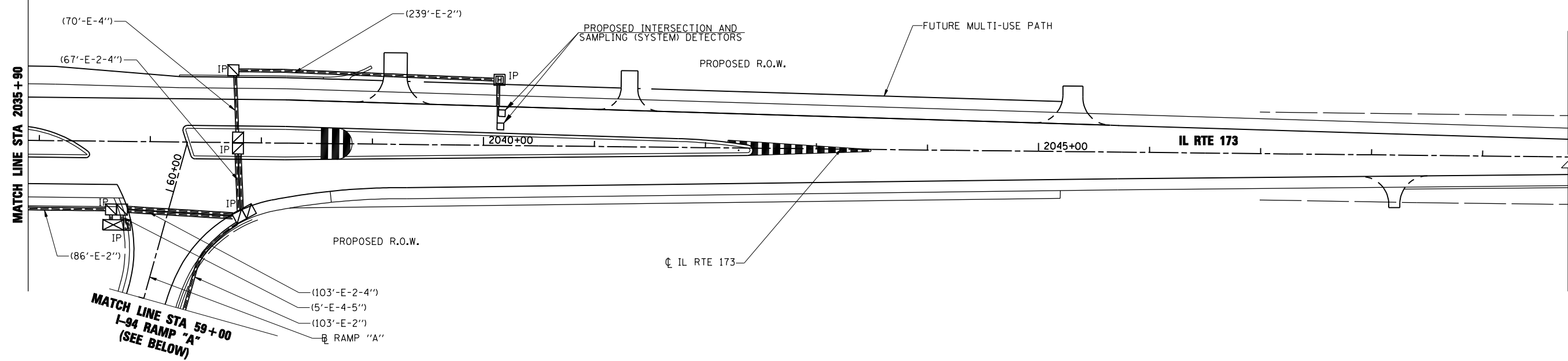

s:\projects\3021.us_41-usa_to_il_173 - bba\proj\sect_work\disiplines\tr-offic_signals\shes\01606L77-shr-ts-27.dgn

EJM ENGINEERING, INC.
 411 South Wells Street Suite 1000
 Chicago, Illinois 60607

FILE NAME =	USER NAME = gra1	DESIGNED - GR	REVISED -
		DRAWN - GR	REVISED -
		CHECKED - BKS	REVISED -
		DATE - 06/19/2012	REVISED -

STATE OF ILLINOIS
DEPARTMENT OF TRANSPORTATION

INTERCONNECT PLAN
IL RTE 173 - HUNT CLUB ROAD TO I-94 RAMP "A"
 SCALE: 1" = 50' SHEET NO. 2 OF 2 SHEETS STA. TO STA.

F.A.I. RTE.	SECTION	COUNTY	TOTAL SHEETS	SHEET NO.
94	49-1-R-1	LAKE	677	358
CONTRACT NO. 60L77			ILLINOIS FED. AID PROJECT	

TS-27

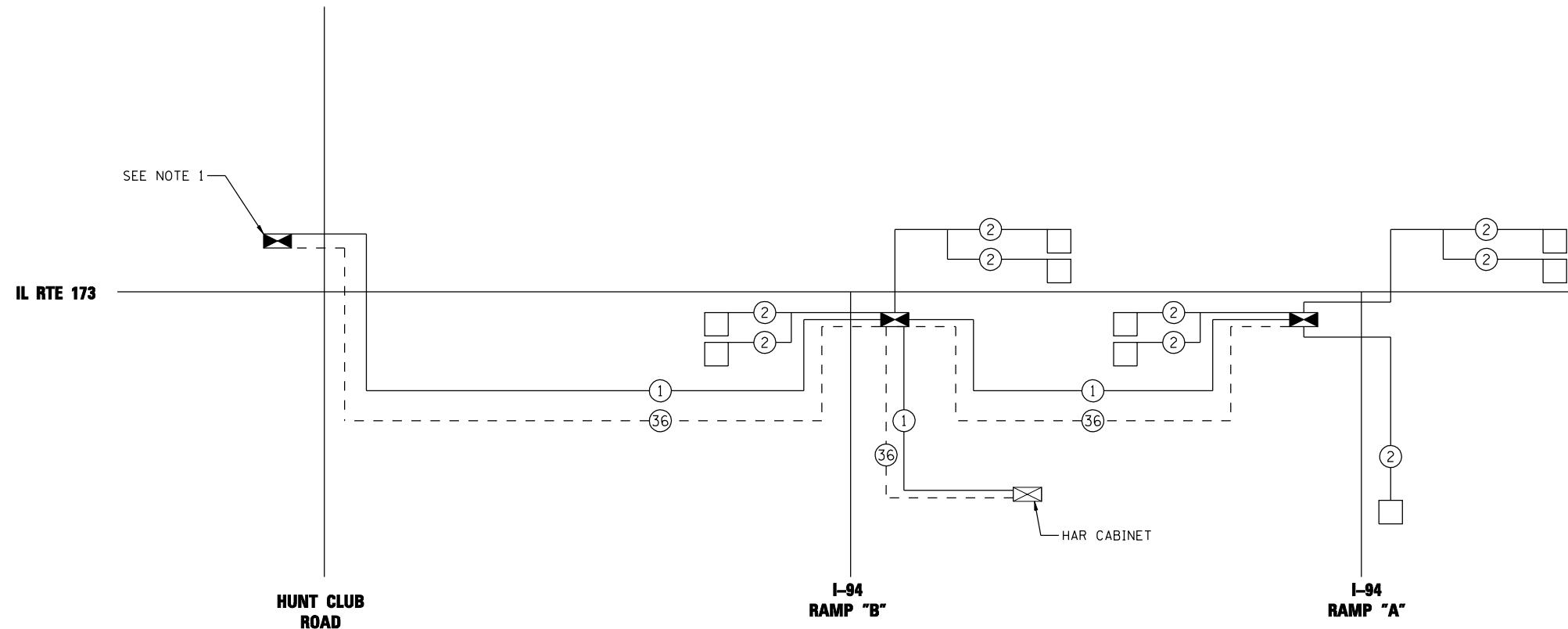

INTERCONNECT SCHEDULE OF QUANTITIES

CODE NUMBER	ITEM	UNIT	TOTAL
81028200	UNDERGROUND CONDUIT, GALVANIZED STEEL, 2" DIA.	FOOT	1660
81100600	CONDUIT ATTACHED TO STRUCTURE, 2" DIA., GALVANIZED STEEL	FOOT	325
81400200	HEAVY-DUTY HANDHOLE	EACH	4
87300925	ELECTRIC CABLE IN CONDUIT, TRACER, NO. 14 1C	FOOT	3096
87900200	DRILL EXISTING HANDHOLE	EACH	1
X8710024	FIBER OPTIC CABLE IN CONDUIT, NO. 62.5/125, MM12F SM24F	FOOT	3096
Z0033056	OPTIMIZE TRAFFIC SIGNAL SYSTEM	EACH	1

NOTES:

- REMOVAL OF THE WIRELESS INTERCONNECT SHALL BE CONSIDERED INCLUDED IN THE COST OF REMOVAL OF THE TEMPORARY SIGNALS. THE TEMPORARY WIRELESS SYSTEM SHALL BE RETURNED TO THE ILLINOIS DEPARTMENT OF TRANSPORTATION.

EJM **EJM ENGINEERING, INC.**
 411 South Wells Street Suite 1000
 Chicago, Illinois 60607

FILE NAME =	USER NAME = grai	DESIGNED - GR	REVISED -
		DRAWN - GR	REVISED -
	PLOT SCALE = none	CHECKED - BKS	REVISED -
	PLOT DATE = 6/18/2012	DATE - 06/19/2012	REVISED -

STATE OF ILLINOIS
DEPARTMENT OF TRANSPORTATION

INTERCONNECT SCHEMATIC	
IL RTE 173 - HUNT CLUB ROAD TO I-94 RAMP "A"	
SCALE: NONE	SHEET NO. 1 OF 1 SHEETS
STA.	TO STA.

F.A.I. RTE.	SECTION	COUNTY	TOTAL SHEETS	SHEET NO.
94	49-1-R-1	LAKE	677	359
CONTRACT NO.			60L77	
ILLINOIS FED. AID PROJECT				

s:\projects\3021.us_41-usa-to-il-173-bba\project\work\disciplines\traffic_signals\sheet\0160L77-sht-ts-28.dgn

NOTE: SIGN DIMENSIONS ARE IN ENGLISH UNITS

PANEL SIGN DESIGN TYPE 2

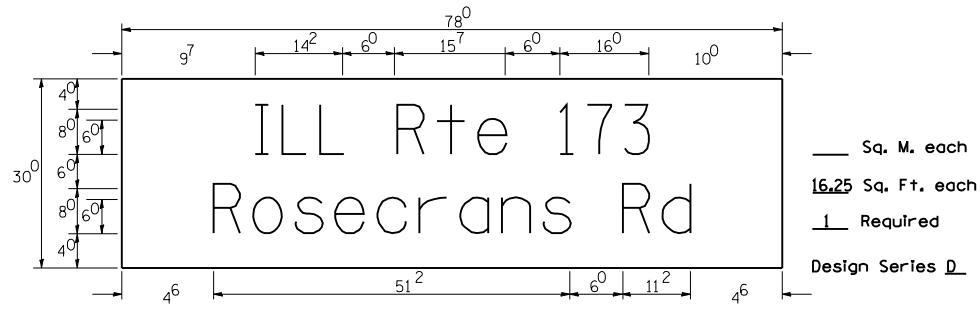

SUPPORTING CHANNELS

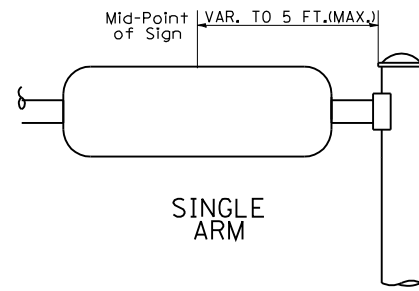
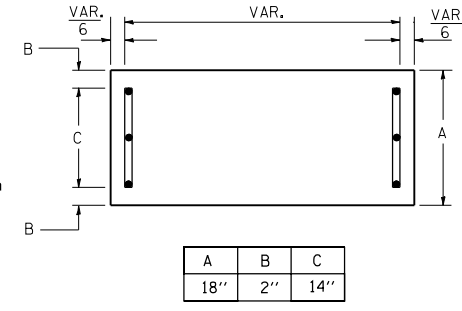

SINGLE ARM

SUPPORTING CHANNELS

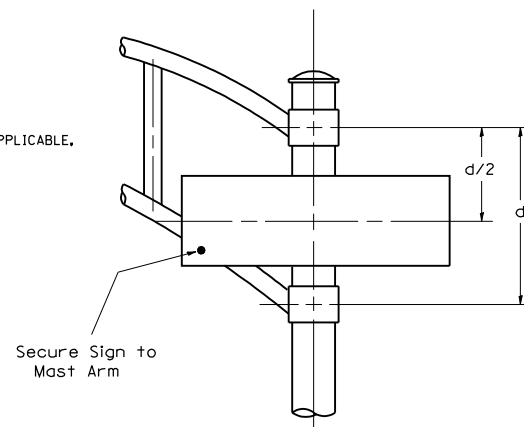
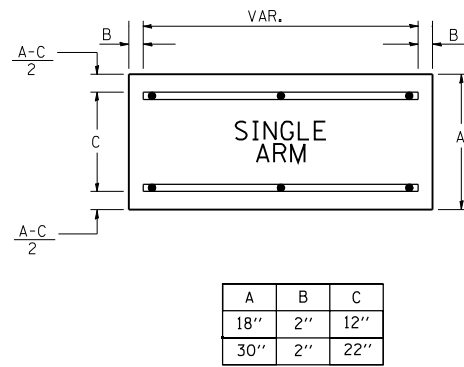

DUAL ARM

SIGNFIX ALUMINUM CHANNEL FRAMING SYSTEM
Shall be used. See Note #5.

GENERAL NOTES

- WHERE MAST ARM MOUNTED STREET NAME SIGNS ARE SPECIFIED, THE MAST ARM ASSEMBLY AND POLES SHALL BE DESIGNED TO SUPPORT THE LOADINGS CALLED FOR ON STANDARDS 877001, 877002, 877006, 877001 AND 877012, AS APPLICABLE, PLUS TWO (2) SIGN PANELS 2'-6" x 8'-0" MOUNTED AS SHOWN. THE DESIGN SHALL BE IN ACCORDANCE WITH THE REQUIREMENTS OF THE CURRENT "STANDARD SPECIFICATIONS FOR STRUCTURAL SUPPORTS FOR HIGHWAY SIGNS, LUMINAIRES, AND TRAFFIC SIGNALS" AS PUBLISHED BY THE AMERICAN ASSOCIATION OF STATE HIGHWAY AND TRANSPORTATION OFFICIALS FOR 80 M.P.H. WIND VELOCITY.
- ALL SIGNS SHALL HAVE A WHITE REFLECTORIZED LEGEND AND BORDER ON A GREEN REFLECTORIZED BACKGROUND, TYPE A SHEETING.
- THE SIGN LENGTH SHOULD BE INCREASED IN 6-INCH INCREMENTS, BUT THE OVERALL LENGTH SHOULD NOT EXCEED 8'-0".
- ALL BORDERS SHALL BE 3/4" WIDE AND CORNER RADIUS SHALL BE 2-1/4".
- SIGNFIX ALUMINUM CHANNEL FRAMING SYSTEM SHALL BE USED FOR ALL SIGNS ATTACHED TO SIGNAL POLES AND POSTS. LOCAL SUPPLIERS OF THE SIGNFIX ALUMINUM CHANNEL FRAMING SYSTEM ARE:
* J.D. HERBERT CO. MIDLOTHIAN, VA. * WESTERN REMAC INC. WOODRIDGE, IL.

PARTS LISTING:
SIGN CHANNEL PART *HPN053 (MED. CHANNEL)
SIGN SCREWS 1/4" x 14 x 1" H.W.H. #3
 SELF TAPPING WITH NEOPRENE WASHER
BRACKETS PART *HPN034 (UNIVERSAL)
 CHANNEL CLAMPS WITH STAINLESS STEEL STRAPPING
OTHER BRANDS OF MOUNTING HARDWARE ARE ACCEPTABLE, BASED UPON THE DEPARTMENT'S APPROVAL AND COMPATIBILITY WITH THE CHANNEL/BACKET OF THE ABOVE PRODUCT.

Upper Case To Lower Case
Spacing Chart 8-6 Inch Series "C & D"

EXAMPLE, 2³ DENOTES 3/8"

FIRST LETTER	SECOND LETTER															
	a c d e		b h i k l		f w		j		s t		v y		x		z	
	C	D	C	D	C	D	C	D	C	D	C	D	C	D	C	D
A W X	12	14	14	15	12	14	06	10	11	14	06	10	11	12	12	14
B	14	15	20	21	14	15	11	12	14	15	12	14	12	14	16	17
C E G	14	15	20	21	12	14	06	10	12	14	12	14	14	15	14	15
D O Q R	14	15	20	21	14	15	06	10	12	14	12	14	14	15	14	15
F	05	06	14	15	06	10	05	06	06	10	06	10	06	10	11	12
H I M N	20	21	22	24	20	21	14	15	16	17	16	17	20	21	20	21
J U	20	21	20	21	16	17	14	15	16	17	16	17	16	17	20	21
K L	11	12	16	17	11	12	05	06	11	12	11	12	11	12	12	14
P	12	14	14	15	12	14	05	06	11	12	11	12	12	14	12	14
S	12	14	16	17	12	14	06	10	12	14	12	14	12	14	12	14
T	11	12	16	17	06	10	06	10	11	12	11	12	11	12	12	14
V	06	10	14	15	11	12	06	10	12	14	12	14	12	14	12	14
Y	05	06	14	15	06	10	05	06	05	07	05	06	06	10	11	12
Z	16	17	22	24	16	17	12	14	16	17	16	17	16	17	20	21

Lower Case To Lower Case
Spacing Chart 6 Inch Series "C & D"

FIRST LETTER	SECOND LETTER															
	a c d e		b h i k l		f w		j		s t		v y		x		z	
	C	D	C	D	C	D	C	D	C	D	C	D	C	D	C	D
a d h g i j	16	17	22	24	16	17	12	14	14	15	14	15	16	17	16	17
l m n q u																
b f k o p s	12	14	16	17	11	12	05	06	11	12	11	12	12	14	12	14
c e	12	14	16	17	12	14	06	10	12	14	12	14	12	14	12	14
r	06	10	12	14	06	10	03	03	05	06	05	06	06	10	06	10
t z	12	14	16	17	12	14	06	10	11	12	11	12	12	14	12	14
v y	11	12	14	15	11	12	05	06	06	10	06	10	11	12	11	12
w	11	12	14	15	11	12	05	06	11	12	11	12	11	12	12	14
x	12	14	16	17	11	12	05	06	11	12	11	12	11	12	12	14

Number To Number
Spacing Chart 8 Inch Series "C & D"

FIRST NUMBER	SECOND NUMBER																			
	0		1		2		3		4		5		6		7		8		9	
	C	D	C	D	C	D	C	D	C	D	C	D	C	D	C	D	C	D	C	D
0 9	16	17	16	17	14	15	12	14	14	15	14	15	16	17	12	14	16	17	16	17
1	20	21	20	21	20	21	16	17	14	15	20	21	20	21	14	15	20	21	20	21
2 3 4	14	15	14	15	14	15	12	14	14	15	14	15	14	15	11	12	16	17	14	15
5	14	15	14	15	14	15	11	12	11	12	14	15	14	15	11	12	14	15	14	15
6	16	17	14	15	14	15	12	15	12	14	14	15	14	15	11	12	14	15	14	15
7	12	14	12	14	14	15	12	15	05	06	12	14	14	15	11	12	14	15	12	14
8	16	17	16	17	14	15	12	15	12	14	14	15	16	17	12	14	16	17	14	15

UPPER AND LOWER CASE
LETTER WIDTHS

LETTERS	6 INCH UPPER CASE LETTERS		8 INCH UPPER CASE LETTERS		LETTERS	6 INCH LOWER CASE LETTERS	
	SERIES		SERIES			SERIES	
	C	D	C	D		C	D
A	3 ⁶	5 ⁰	5 ⁰	6 ⁵	a	3 ⁵	4 ²
B	3 ²	4 ⁰	4 ³	5 ³	b	3 ⁵	4 ²
C	3 ²	4 ⁰	4 ³	5 ³	c	3 ⁵	4 ¹
D	3 ²	4 ⁰	4 ³	5 ³	d	3 ⁵	4 ²
E	3 ⁰	3 ⁵	4 ⁰	4 ⁷	e	3 ⁵	4 ²
F	3 ⁰	3 ⁵	4 ⁰	4 ⁷	f	2 ³	2 ⁶
G	3 ²	4 ⁰	4 ³	5 ³	g	3 ⁵	4 ²
H	3 ²	4 ⁰	4 ³	5 ³	h	3 ⁵	4 ²
I	0 ⁷	0 ⁷	1 ¹	1 ²	i	1 ¹	1 ¹
J	3 ⁰	3 ⁶	4 ⁰	5 ⁰	j	2 ⁰	2 ²
K	3 ²	4 ¹	4 ³	5 ⁴	k	3 ⁵	4 ²
L	3 ⁰	3 ⁵	4 ⁰	4 ⁷	l	1 ¹	1 ¹
M	3 ⁷	4 ⁵	5 ¹	6 ¹	m	6 ⁰	7 ⁰
N	3 ²	4 ⁰	4 ³	5 ³	n	3 ⁵	4 ²
O	3 ⁴	4 ²	4 ⁵	5 ⁵	o	3 ⁶	4 ³
P	3 ²	4 ⁰	4 ³	5 ³	p	3 ⁵	4 ²
Q	3 ⁴	4 ²	4 ⁵	5 ⁵	q	3 ⁵	4 ²
R	3 ²	4 ⁰	4 ³	5 ³	r	2 ⁶	3 ²
S	3 ²	4 ⁰	4 ³	5 ³	s	3 ⁶	4 ²
T	3 ⁰	3 ⁵	4 ⁰	4 ⁷	t	2 ⁷	3 ²
U	3 ²	4 ⁰	4 ³	5 ³	u	3 ⁵	4 ²
V	3 ⁵	4 ⁴	4 ⁷	6 ⁰	v	4 ²	4 ⁷
W	4 ⁴	5 ²	6 ⁰	7 ⁰	w	5 ⁵	6 ⁴
X	3 ⁴	4 ⁰	4 ⁵	5 ³	x	4 ⁴	5 ¹
Y	3 ⁶	5 ⁰	5 ⁰	6 ⁶	y	4 ⁶	5 ³
Z	3 ²	4 ⁰	4 ³	5 ³	z	3 ⁶	4 ³

NUMBER	6 INCH SERIES		8 INCH SERIES	
	C	D	C	D
1	1 ²	1 ⁴	1 ⁵	2 ⁰
2	3 ²	4 ⁰	4 ³	5 ³
3	3 ²	4 ⁰	4 ³	5 ³
4	3 ⁵	4 ³	4 ⁷	5 ⁷
5	3 ²	4 ⁰	4 ³	5 ³
6	3 ²	4 ⁰	4 ³	5 ³
7	3 ²	4 ⁰	4 ³	5 ³
8	3 ²	4 ⁰	4 ³	5 ³
9	3 ²	4 ⁰	4 ³	5 ³
0	3 ⁴	4 ²	4 ⁵	5 ⁵

FILE NAME =	USER NAME = grot	DESIGNED - CDM	REVISED -
*FILE#		DRAWN - CDM	REVISED -
	PLOT SCALE = 106.0000' / IN.	CHECKED - BKS	REVISED -
	PLOT DATE = 6/18/2012	DATE - 11-21-2011	REVISED -

STATE OF ILLINOIS
DEPARTMENT OF TRANSPORTATION

DISTRICT 1		
MAST ARM MOUNTED STREET NAME SIGNS		
SCALE: NONE	SHEET NO. 1 OF 1 SHEETS	STA. TO STA.

F.A.I. RTE. 94	SECTION 49-1-R-1	COUNTY LAKE	TOTAL SHEETS 677	SHEET NO. 360
ILLINOIS FED. AID PROJECT			CONTRACT NO. 60L77	

IDOT LEGEND

	EXISTING IDOT LIGHTING UNIT
	PROPOSED LIGHTING UNIT 47.5' M.H., 6' D.A., WITH 400W, 240V PHASE TO NEUTRAL HPS LUMINAIRE, MC III
	PROPOSED LIGHTING UNIT 47.5' M.H., 15' D.A., WITH 400W, 240V PHASE TO NEUTRAL HPS LUMINAIRE, MC III WITH TRANSFORMER BASE BREAKAWAY DEVICE
	PROPOSED LIGHTING UNIT ON COMBINATION TRAFFIC SIGNAL POLE 45' M.H., 15' D.A., WITH 400W, 240V PHASE TO NEUTRAL HPS LUMINAIRE, MC III
	PROPOSED LIGHTING UNIT 47.5' M.H., 10' D.A., WITH 400W, 240V PHASE TO NEUTRAL HPS LUMINAIRE, MC III WITH TRANSFORMER BASE BREAKAWAY DEVICE
	PROPOSED 180 DEGREE DUAL ARM LIGHTING UNIT 47.5' M.H., DUAL 6' D.A., WITH 400W, 240V HPS LUMINAIRES
	PROPOSED 90 DEGREE DUAL ARM LIGHTING UNIT 47.5' M.H., DUAL 10' D.A., WITH 400W, 240V HPS LUMINAIRES
	PROPOSED 90 DEGREE DUAL ARM LIGHTING UNIT 47.5' M.H., DUAL 15' D.A., WITH 400W, 240V HPS LUMINAIRES
	TEMPORARY LIGHTING UNIT 50' M.H., 15' MAST ARM., WITH 400W, 240V HPS LUMINAIRE, TYPE III, 6 AMP FUSE
	EXISTING TEMPORARY LIGHTING UNIT INSTALLED IN PREVIOUS CONTRACT 60L76 (TO BE REMOVED IN THIS CONTRACT)
	EXISTING LIGHTING UNIT TO BE REMOVED AND SALVAGED
	EXISTING UNDERPASS LUMINAIRE TO BE REMOVED
	PROPOSED UNDERPASS LUMINAIRE, WATTAGE AND TYPE PER PLANS
	UNDERGROUND RIGID GALVANIZED STEEL CONDUIT (RGSC) SIZE AND LENGTH AS INDICATED
	UNIT DUCT, AS SPECIFIED IN PLANS
	EXISTING CABLE AND CONDUIT TO REMAIN IN PLACE
	EXISTING OVERHEAD UTILITY POWER LINE
	AERIAL CABLE, AS SPECIFIED IN PLANS
	PROPOSED LIGHTING CONTROLLER CABINET, SINGLE DOOR, CONSOLE TYPE, 240/480V, SINGLE PHASE, 3 WIRE
	PROPOSED LIGHTING CONTROLLER CABINET, DOUBLE DOOR, CONSOLE TYPE, RADIO CONTROLLED CONTROLLER 240/480V, SINGLE PHASE, 3 WIRE
	EXISTING LIGHTING CONTROLLER CABINET
	EXISTING LIGHTING CONTROLLER CABINET TO BE REMOVED
	GROUND ROD, 5/8" DIA. X 10 FT
	WOOD POLE, SIZE AS NOTED
	PROPOSED ELECTRIC UTILITY SERVICE TRANSFORMER
	EXISTING ELECTRIC UTILITY SERVICE TRANSFORMER
	JUNCTION BOX, SIZE AND TYPE AS NOTED
	EXISTING HANDHOLE TO BE REMOVED

IDOT ELECTRICAL BILL OF MATERIALS

ITEM	UNIT	QUANTITY
ELECTRIC SERVICE INSTALLATION	EACH	3
ELECTRIC UTILITY SERVICE CONNECTION	L SUM	1
UNDERGROUND CONDUIT, GALVANIZED STEEL, 3" DIA.	FOOT	2253
CONDUIT ATTACHED TO STRUCTURE, 1" DIA., PVC COATED GALVANIZED STEEL	FOOT	1103
CONDUIT EMBEDDED IN STRUCTURE, 2" DIA., PVC	FOOT	463
JUNCTION BOX, STAINLESS STEEL, ATTACHED TO STRUCTURE, 6" X 6" X 4"	EACH	14
JUNCTION BOX, STAINLESS STEEL, ATTACHED TO STRUCTURE, 12" X 10" X 6"	EACH	20
JUNCTION BOX, STAINLESS STEEL, ATTACHED TO STRUCTURE, 16" X 14" X 6"	EACH	2
UNIT DUCT, 600V, 3-1/C NO.2, 1/C NO.4 GROUND, (XLP-TYPE USE), 1 1/2" DIA. POLYETHYLENE	FOOT	3616
UNIT DUCT, 600V, 3-1/C NO.4, 1/C NO.6 GROUND, (XLP-TYPE USE), 1 1/4" DIA. POLYETHYLENE	FOOT	33129
ELECTRIC CABLE IN CONDUIT, 600V (XLP-TYPE USE) 1/C NO. 10	FOOT	4557
ELECTRIC CABLE IN CONDUIT, 600V (XLP-TYPE USE) 1/C NO. 2	FOOT	105
ELECTRIC CABLE IN CONDUIT, 600V (XLP-TYPE USE) 1/C 350 MCM	FOOT	150
AERIAL CABLE, 3-1/C NO. 4 WITH MESSENGER WIRE	FOOT	7273
LUMINAIRE, SODIUM VAPOR, HORIZONTAL MOUNT, 400 WATT	EACH	172
UNDERPASS LUMINAIRE, 70 WATT, HIGH PRESSURE SODIUM VAPOR	EACH	6
UNDERPASS LUMINAIRE, 100 WATT, HIGH PRESSURE SODIUM VAPOR	EACH	8
LIGHTING CONTROLLER, BASE MOUNTED, 480VOLT, 100AMP	EACH	1
LIGHT POLE, ALUMINUM, 47.5 FT. M.H., 6 FT. DAVIT ARM	EACH	2
LIGHT POLE, ALUMINUM, 47.5 FT. M.H., 10 FT. DAVIT ARM	EACH	104
LIGHT POLE, ALUMINUM, 47.5 FT. M.H., 15 FT. DAVIT ARM	EACH	19
LIGHT POLE, ALUMINUM, 47.5 FT. M.H., 2-6 FT. DAVIT ARMS	EACH	5
LIGHT POLE, WOOD, 60 FOOT, CLASS 4, WITH 15FT MAST ARM	EACH	30
LIGHT POLE FOUNDATION, 24" DIAMETER	FOOT	1200
BREAKAWAY DEVICE, TRANSFORMER BASE, 15 INCH BOLT CIRCLE	EACH	126
REMOVAL OF TEMPORARY LIGHTING UNIT	EACH	51
REMOVAL OF LIGHTING UNIT, SALVAGE	EACH	25
REMOVAL OF POLE FOUNDATION	EACH	19
REMOVAL OF LIGHTING CONTROLLER	EACH	1
REMOVAL OF LIGHTING CONTROLLER FOUNDATION	EACH	1
REMOVE EXISTING HANDHOLE	EACH	2
WOOD POLE, 60 FT, CLASS 4	EACH	1
TEMPORARY LIGHTING CONTROLLER	EACH	1
LIGHTING CONTROLLER, BASE MOUNTED, 480VOLT, 200AMP (DUAL), RADIO SCADA	EACH	1
LUMINAIRE SAFETY CABLE ASSEMBLY	EACH	142
MAINTENANCE OF LIGHTING SYSTEM	CAL MO	11
JUNCTION BOX, NON-METALLIC, EMBEDDED IN STRUCTURE, 12" X 10" X 6"	EACH	4
LIGHT POLE, ALUMINUM, 47.5 FT. M.H., 2-15 FT. DAVIT ARMS	EACH	1
LIGHT POLE, ALUMINUM, 47.5 FT. M.H., 2-10 FT. DAVIT ARMS	EACH	2

GENERAL NOTES:

- BREAKAWAY DEVICE, TRANSFORMER BASE, 9", FOR 47.5' LIGHT POLES SHALL BE INSTALLED ON ALL GROUND MOUNTED POLES WITH 15" BOLT CIRCLE ON 24" DIA. FOUNDATION AS SHOWN IN THE PLANS.
- WHEREVER TEMPORARY AERIAL CABLE IS REQUIRED TO CROSS AN EXISTING AND/OR PROPOSED ROADWAY, THE CONTRACTOR SHALL MAINTAIN A MINIMUM OF 20 FEET OF VERTICAL CLEARANCE OVER THE ROADWAY AT ALL TIMES.
- SETBACKS ARE MEASURED FROM EDGE OF TRAVELED PAVEMENT TO CENTER OF POLE.
- OFFSETS FOR TEMPORARY LIGHT POLES ARE MEASURED TO CENTER OF WOOD POLE.
- REMOVAL OF SIGN LIGHTING (INCLUDING ALL ASSOCIATED CONDUIT, WIRE, JUNCTION BOXES, AND HARDWARE) FOR OVERHEAD SIGN STRUCTURES TO BE REMOVED IS INCLUDED IN THE PRICE OF THE SIGN STRUCTURE REMOVAL.

CALL-OUT SAMPLES

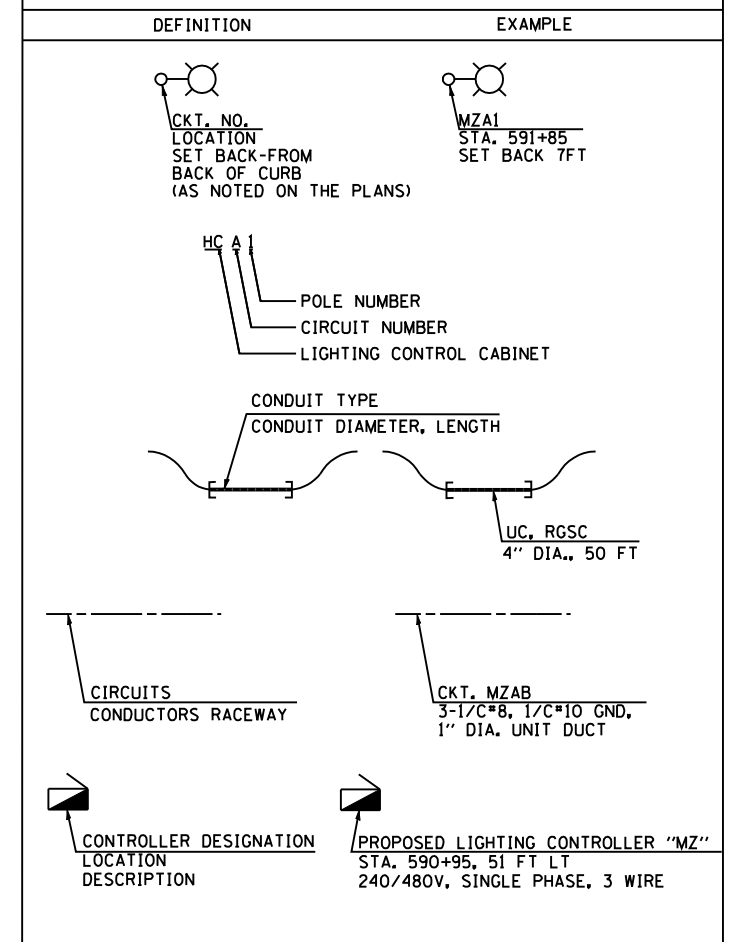

ABBREVIATIONS

ABBREVIATION	DESCRIPTION
AC	ALTERNATING CURRENT
A/C	AERIAL CABLE
AFG	ABOVE FINISHED GRADE
CB	CIRCUIT BREAKER
CKT	CIRCUIT
CM	CENTIMETER
CNC	COILABLE NONMETALLIC CONDUIT
CT	CURRENT TRANSFORMER
CP	CONTROL PANEL
D.A.	DAVIT ARM
DIA.	DIAMETER
E	EXISTING UNIT TO REMAIN
ECA	ELECTRIC CABLE ASSEMBLY
FT	FEET OR FOOT
FND MET	FOUNDATION METAL
FU	FUSE
GND	GROUND
HID	HIGH INTENSITY DISCHARGE
HPS	HIGH PRESSURE SODIUM
JB	JUNCTION BOX
KVA	KILOVOLT-AMPERE
KW	KILOWATTS
LP	LIGHT POLE
M	METER
M.A.	MAST ARM
M.H.	MOUNTING HEIGHT
NO. #	NUMBER
RGSC	RIGID GALVANIZED STEEL CONDUIT
STA	STATION
T	TEMPORARY LIGHTING UNIT
TB	TRANSFORMER BASE
TMP	TEMPORARY
UC	UNDERGROUND CONDUIT
UD	UNIT DUCT
WP	WOOD POLE
XFMR	TRANSFORMER

S:\Projects\3831 US 41\Draws to IL\73 - BBA\Project Work\Disciplines\Electrical\Sheets\068-77-ah-1-light-01.dgn



FILE NAME	USER NAME = rsonson	DESIGNED - RAS	REVISED -
		DRAWN - BHH	REVISED -
	PLOT SCALE = NONE / IN.	CHECKED - MKR	REVISED -
	PLOT DATE = 6/18/2012	DATE - 6/19/2012	REVISED -

**STATE OF ILLINOIS
DEPARTMENT OF TRANSPORTATION**

**IDOT LIGHTING GENERAL NOTES AND LEGEND
I-94 FROM ROSECRANS RD TO STATE LINE**

SCALE: NONE	SHEET NO. 1 OF 53 SHEETS	STA. TO STA.	F.A. RTE.	SECTION	COUNTY	TOTAL SHEETS	SHEET NO.
			94	49-I-R-1	LAKE	677	361
						CONTRACT NO. 60L77	
ILLINOIS FED. AID PROJECT							

s:\projects\2012\11-173 - bba\proj\set\work\disciplines\electrical\sheet\0166-77-11-173-11-173-11-173.dwg

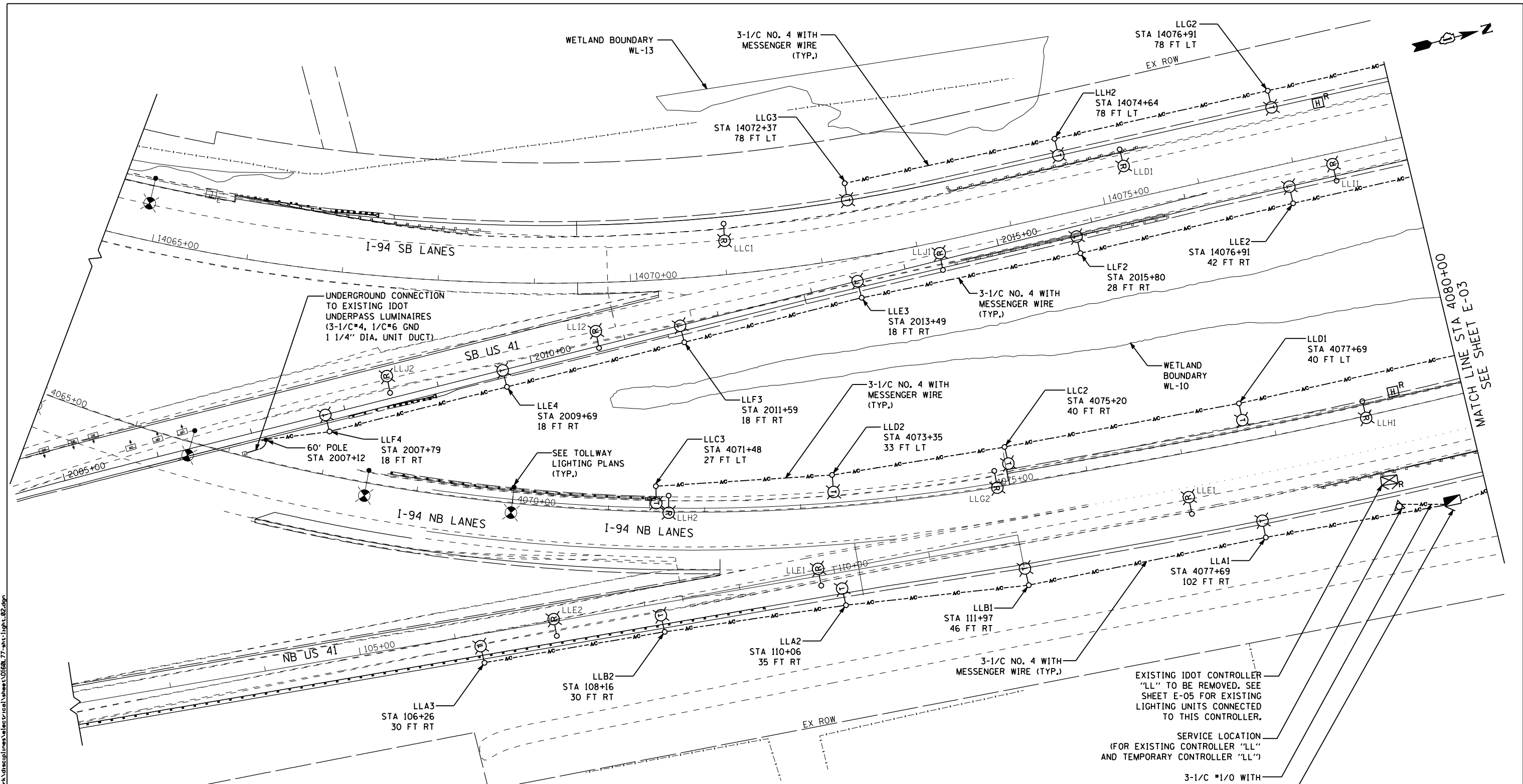

EXISTING IDOT CONTROLLER "LL" TO BE REMOVED. SEE SHEET E-05 FOR EXISTING LIGHTING UNITS CONNECTED TO THIS CONTROLLER.
 SERVICE LOCATION (FOR EXISTING CONTROLLER "LL" AND TEMPORARY CONTROLLER "LL")
 3-1/8" #1/0 WITH MESSENGER WIRE (SEE NOTE 2)
 TEMPORARY IDOT LIGHTING CONTROLLER "LL" (SEE NOTE 3)

- NOTES:**
- EXISTING REMOVED IDOT LIGHTING UNITS SHALL BE SALVAGED TO IDOT IN ACCORDANCE WITH ARTICLE 842.03(b) OF THE STANDARD SPECIFICATIONS.
 - SERVICE CABLE FOR TEMPORARY CONTROLLER "LL" IS INCLUDED IN THE COST OF THE TEMPORARY CONTROLLER.
 - TEMPORARY CONTROLLER "LL" SHALL BE PER DISTRICT ONE DETAIL BE-215, BUT SHALL BE MOUNTED ON A WOOD PLATFORM IN PLACE OF A CONCRETE FOUNDATION.
 - OFFSETS FOR TEMPORARY LIGHT POLES ARE MEASURED TO CENTER OF WOOD POLE.

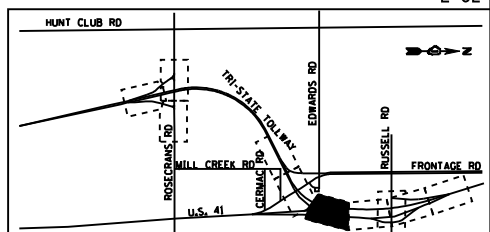
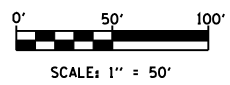

EJM ENGINEERING, INC.
 411 South Wells Street Suite 1000
 Chicago, Illinois 60607

FILE NAME	USER NAME = rsonson	DESIGNED - RAS	REVISED -
		DRAWN - BHH	REVISED -
		CHECKED - MKR	REVISED -
		DATE - 6/19/2012	REVISED -

STATE OF ILLINOIS
DEPARTMENT OF TRANSPORTATION

IDOT TEMPORARY LIGHTING AND REMOVAL PLAN
I-94 FROM ROSECRANS RD TO STATE LINE
 SCALE: 1"=50' SHEET NO. 2 OF 53 SHEETS STA. 4065+00 TO STA. 4080+00

F.A. RTE.	SECTION	COUNTY	TOTAL SHEETS	SHEET NO.
94	49-1-R-1	LAKE	677	362
CONTRACT NO. 60L77				
ILLINOIS FED. AID PROJECT				

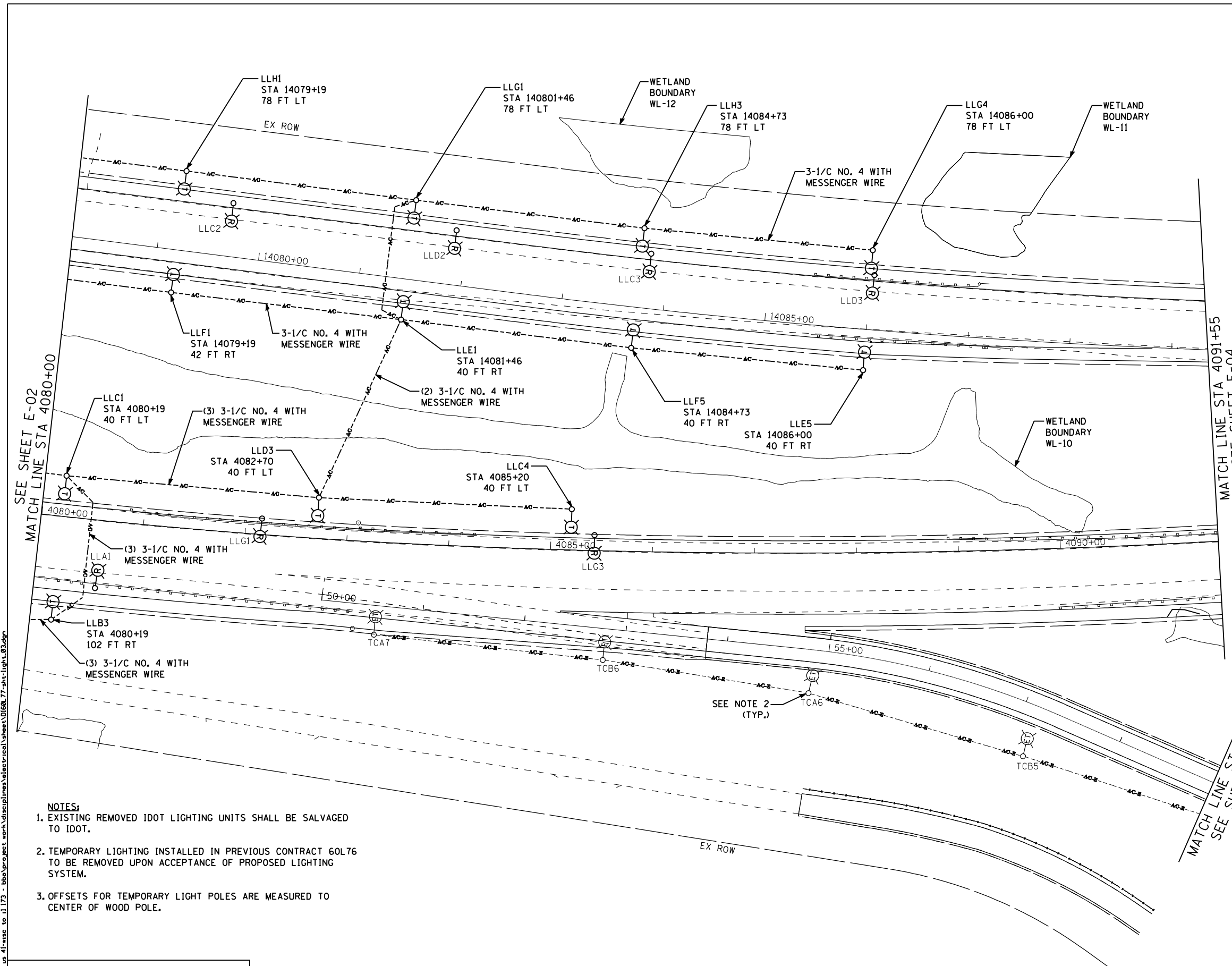

- NOTES:**
- EXISTING REMOVED IDOT LIGHTING UNITS SHALL BE SALVAGED TO IDOT.
 - TEMPORARY LIGHTING INSTALLED IN PREVIOUS CONTRACT 60L76 TO BE REMOVED UPON ACCEPTANCE OF PROPOSED LIGHTING SYSTEM.
 - OFFSETS FOR TEMPORARY LIGHT POLES ARE MEASURED TO CENTER OF WOOD POLE.

EJM ENGINEERING, INC.
 411 South Wells Street Suite 1000
 Chicago, Illinois 60607

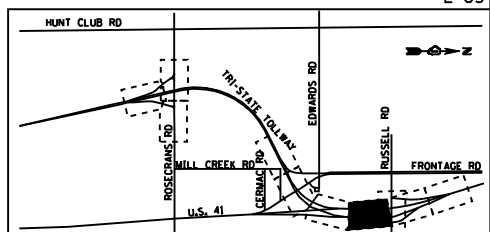
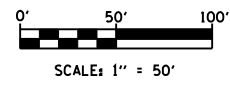

FILE NAME	USER NAME = rsonson	DESIGNED - RAS	REVISED -
		DRAWN - BHH	REVISED -
		CHECKED - MKR	REVISED -
		DATE - 6/19/2012	REVISED -

**STATE OF ILLINOIS
 DEPARTMENT OF TRANSPORTATION**

**IDOT TEMPORARY LIGHTING AND REMOVAL PLAN
 I-94 FROM ROSECRANS RD TO STATE LINE**

SCALE: 1"=50' SHEET NO. 4 OF 53 SHEETS STA. 4080+00 TO STA. 4091+55

F.A. RTE.	SECTION	COUNTY	TOTAL SHEETS	SHEET NO.
94	49-1-R-1	LAKE	677	363
CONTRACT NO. 60L77				
ILLINOIS FED. AID PROJECT				

s:\projects\2012\11-173 - bba\proj\set work\disciplines\electrical\sheet\1173-light_03.dwg

MATCH LINE STA 4091+55
 SEE SHEET E-04

MATCH LINE STA 4080+00
 SEE SHEET E-02

MATCH LINE STA 59+00
 SEE SHEET E-04

E-03

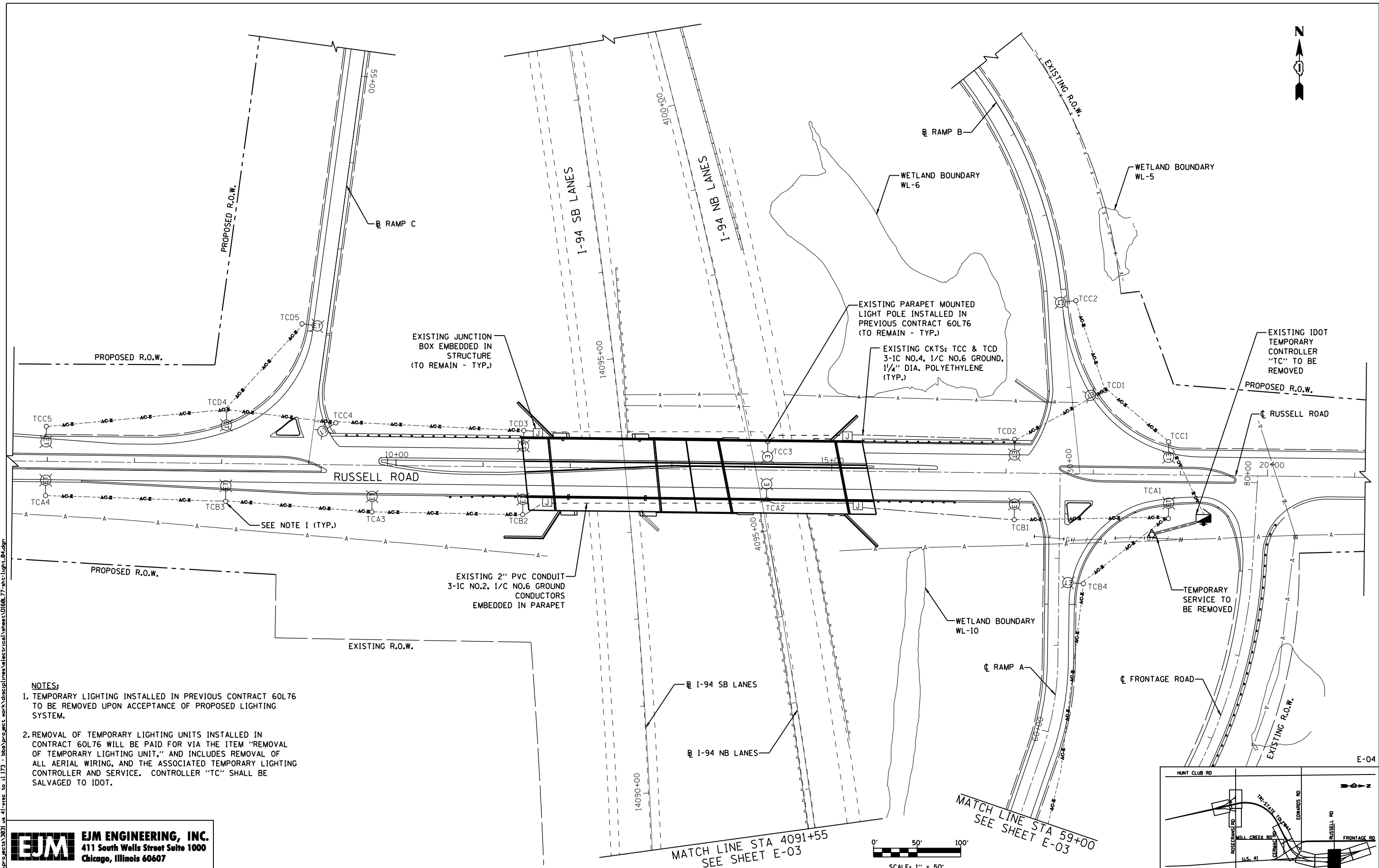

- NOTES:**
1. TEMPORARY LIGHTING INSTALLED IN PREVIOUS CONTRACT 60L76 TO BE REMOVED UPON ACCEPTANCE OF PROPOSED LIGHTING SYSTEM.
 2. REMOVAL OF TEMPORARY LIGHTING UNITS INSTALLED IN CONTRACT 60L76 WILL BE PAID FOR VIA THE ITEM "REMOVAL OF TEMPORARY LIGHTING UNIT," AND INCLUDES REMOVAL OF ALL AERIAL WIRING, AND THE ASSOCIATED TEMPORARY LIGHTING CONTROLLER AND SERVICE. CONTROLLER "TC" SHALL BE SALVAGED TO IDOT.

EJM ENGINEERING, INC.
 411 South Wells Street Suite 1000
 Chicago, Illinois 60607

FILE NAME	USER NAME = rsonson	DESIGNED - RAS	REVISED -
		DRAWN - BHH	REVISED -
		CHECKED - MKR	REVISED -
		DATE - 6/19/2012	REVISED -

**STATE OF ILLINOIS
 DEPARTMENT OF TRANSPORTATION**

**IDOT TEMPORARY LIGHTING AND REMOVAL PLAN
 RUSSELL ROAD**
 SCALE: 1" = 50' SHEET NO. 5 OF 53 SHEETS STA. 5+60 TO STA. 21+13

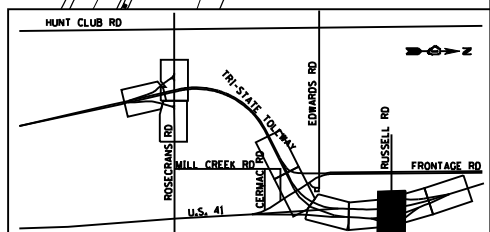

F.A. RTE.	SECTION	COUNTY	TOTAL SHEETS	SHEET NO.
94	49-1-R-1	LAKE	677	364
CONTRACT NO. 60L77				
ILLINOIS FED. AID PROJECT				

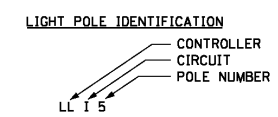
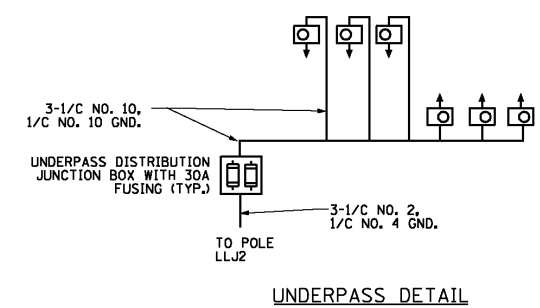
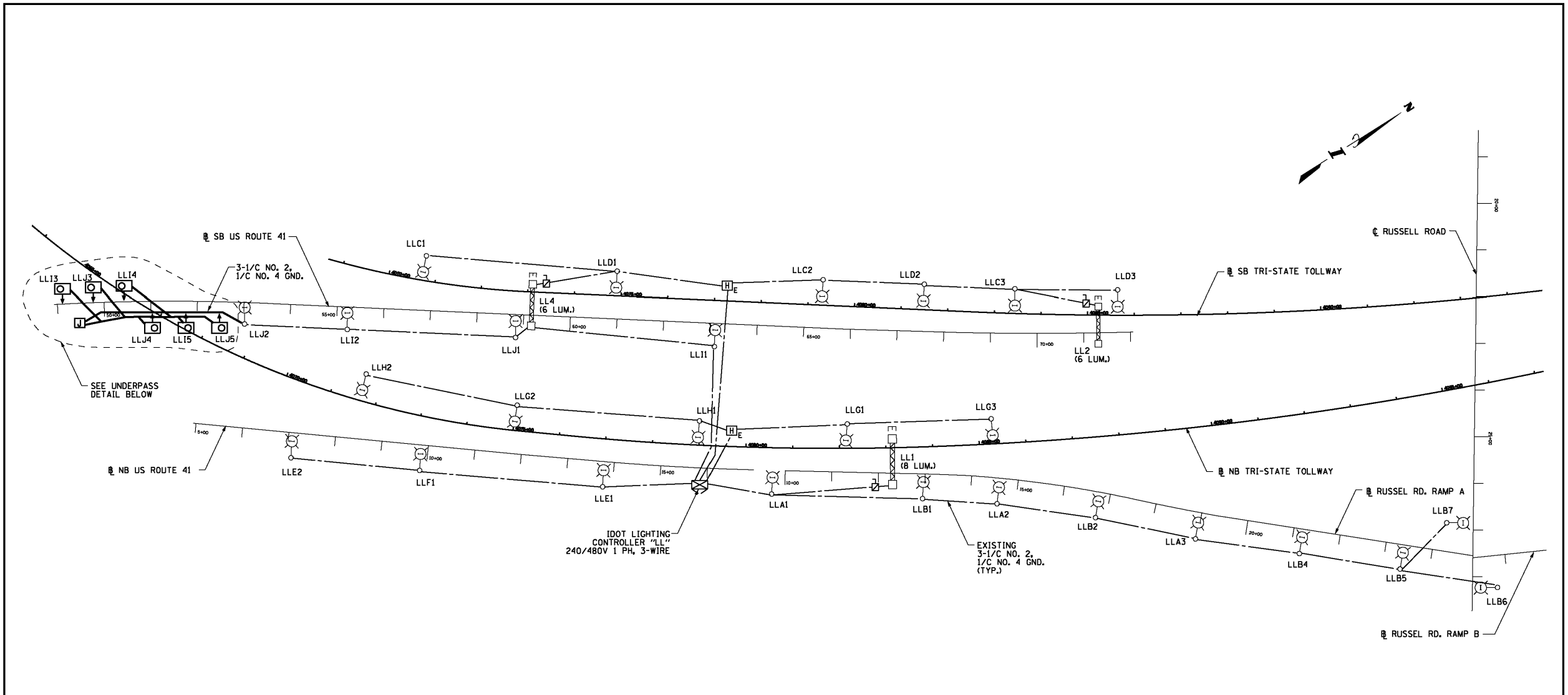

- LEGEND:**
- ◻ EXISTING IDOT OVERHEAD LIGHTED SIGN
 - EXISTING IDOT LIGHT POLE WITH 200W, LUMINAIRE UNLESS NOTED OTHERWISE.
 - ⊕ PROPOSED 70W HPS UNDERPASS LUMINAIRE
 - ⊞ FUSED DISCONNECT

LOAD TABULATION FOR LIGHTING CONTROLLER "LL"
SYSTEM VOLTAGE 240/480V, SINGLE PHASE, 4-WIRE

CKTS #	DESCRIPTION	PHASE A AMPS	PHASE B AMPS
A	3-200W HPS LUM., 4 SIGN LUM.	6.1	
B	6-200W HPS LUM., 4 SIGN LUM.		9.4
C	3-200W HPS LUM., 6 SIGN LUM.	7.5	
D	3-200W HPS LUM., 6 SIGN LUM.		7.5
E	2-200W HPS LUM.	2.2	
F	1-200W HPS LUM.		1.1
G	3-200W HPS LUM.	3.3	
H	2-200W HPS LUM.		2.2
I	2-200W HPS LUM., 3-70W UNDERPASS LUM.	4.6	
J	2-200W HPS LUM., 3-70W UNDERPASS LUM.		4.6
TOTAL		23.7	24.8

200W HPS LUMINAIRE - 1.1A
SIGN LUMINAIRE - 0.7A
70W HPS UNDERPASS LUMINAIRE - 0.8 AMP

DRAWN BY... *MLB* DATE 10/16/2008
CHECKED BY... *MLL* SCALE NONE

ENGINEERING CONSULTANT
CG **Ciorba Group, Inc.**
CONSULTING ENGINEERS
5507 North Cumberland Avenue, Suite 402 Chicago, Illinois 60656
Tel. 773.775.4009 Fax 773.775.4014 Email: chicago@ciorba.com

THE ILLINOIS STATE TOLL HIGHWAY AUTHORITY
2700 OGDEN AVENUE
DOWNERS GROVE, ILLINOIS 60515

REVISIONS	
NO.	DESCRIPTION

CONTRACT NO. I-07-5237
LIGHTING CONTROLLER "LL"
SINGLE LINE DIAGRAM

DRAWING NO. .223. OF .402.

EJM ENGINEERING, INC.
411 South Wells Street Suite 1000
Chicago, Illinois 60607

FILE NAME	USER NAME	DESIGNED	REVISED
	rasonson	- RAS	-
		DRAWN - BHH	REVISED -
		CHECKED - MKR	REVISED -
		DATE - 6/19/2012	REVISED -

**STATE OF ILLINOIS
DEPARTMENT OF TRANSPORTATION**

**I-94 FROM ROSECRANS RD TO STATE LINE
SINGLE LINE DIAGRAM - EXISTING IDOT CONTROLLER "LL"**
SCALE: NONE SHEET NO. 3 OF 53 SHEETS STA. TO STA.

F.A. RTE.	SECTION	COUNTY	TOTAL SHEETS	SHEET NO.
94	49-I-R-1	LAKE	677	365
CONTRACT NO. 60L77				
ILLINOIS FED. AID PROJECT				

FOR REFERENCE ONLY

E-05

I:\projects\2011 us 41-mse to i173 - bba\proj\set work\disciplines\electrical\sheet\01686-77-1ht-light_06.dwg

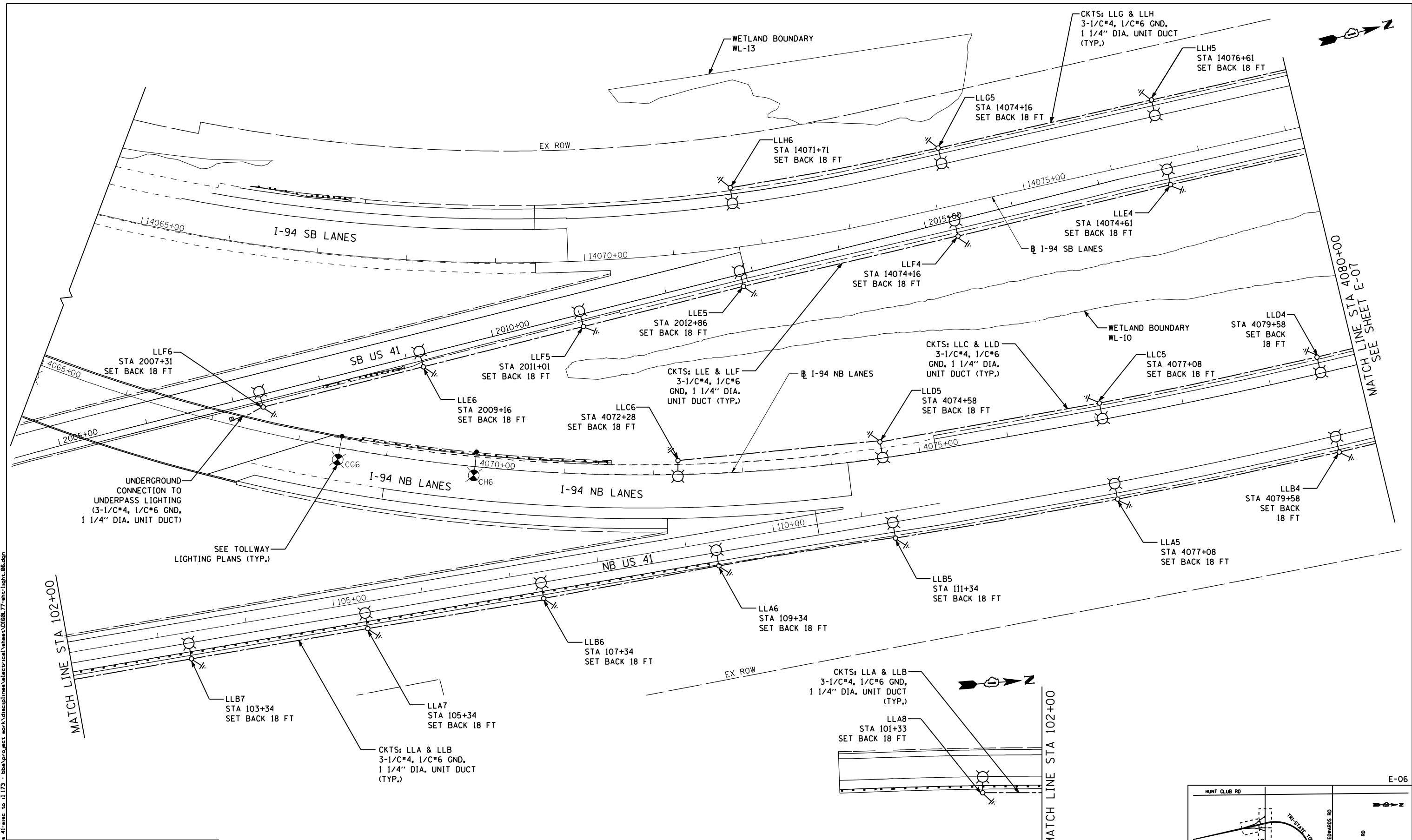

NOTES:
1. SETBACKS ARE MEASURED FROM EDGE OF TRAVELED PAVEMENT TO CENTER OF POLE.

EJM ENGINEERING, INC.
411 South Wells Street Suite 1000
Chicago, Illinois 60607

FILE NAME	USER NAME = rsonson	DESIGNED - RAS	REVISED -
		DRAWN - BHH	REVISED -
		CHECKED - MKR	REVISED -
		DATE - 6/19/2012	REVISED -

**STATE OF ILLINOIS
DEPARTMENT OF TRANSPORTATION**

PROPOSED IDOT LIGHTING PLAN
I-94 FROM ROSECRANS RD TO STATE LINE

SCALE: 1"=50' SHEET NO. 6 OF 53 SHEETS STA. 4065+00 TO STA. 4080+00

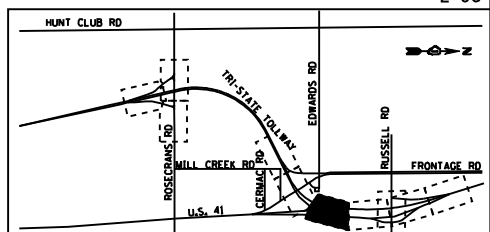
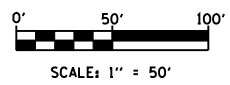

F.A. RTE.	SECTION	COUNTY	TOTAL SHEETS	SHEET NO.
94	49-1-R-1	LAKE	677	366
CONTRACT NO. 60L77				
ILLINOIS FED. AID PROJECT				

s:\projects\2012\11-173 - bba\proj\set work\disciplines\electrical\sheet\0606-77-sh-1-light-06.dgn

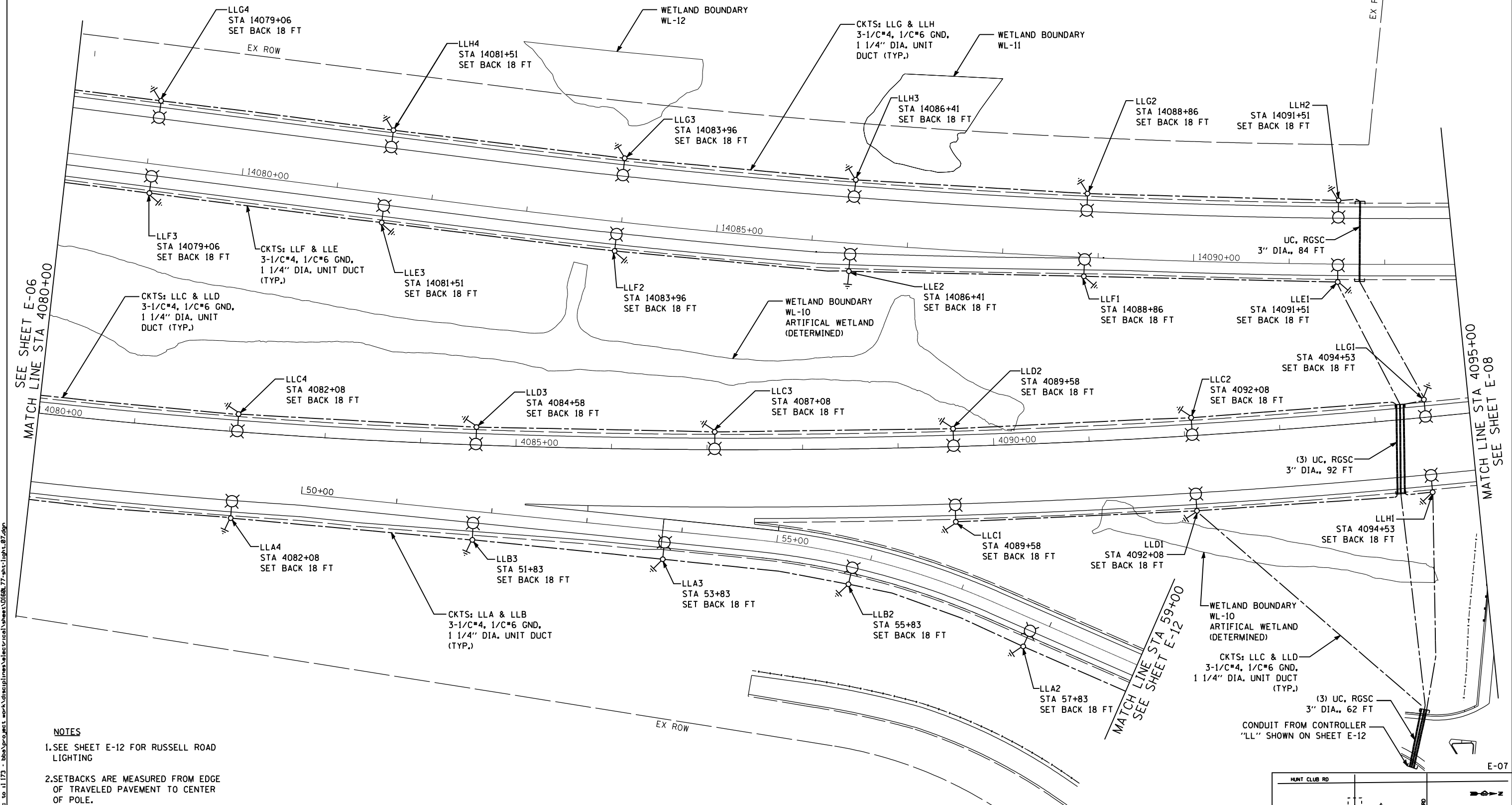

SEE SHEET E-06
MATCH LINE STA 4080+00

MATCH LINE STA 4095+00
SEE SHEET E-08

MATCH LINE STA 59+00
SEE SHEET E-12

- NOTES**
- SEE SHEET E-12 FOR RUSSELL ROAD LIGHTING
 - SETBACKS ARE MEASURED FROM EDGE OF TRAVELED PAVEMENT TO CENTER OF POLE.

EJM ENGINEERING, INC.
411 South Wells Street Suite 1000
Chicago, Illinois 60607

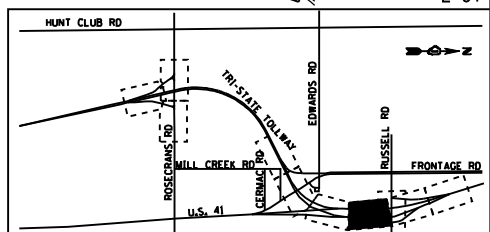
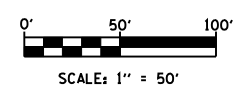

FILE NAME	USER NAME = rsonson	DESIGNED - RAS	REVISED -
		DRAWN - BHH	REVISED -
		CHECKED - MKR	REVISED -
		DATE - 6/19/2012	REVISED -

**STATE OF ILLINOIS
DEPARTMENT OF TRANSPORTATION**

**PROPOSED IDOT LIGHTING PLAN
I-94 FROM ROSECRANS RD TO STATE LINE**

SCALE: 1"=50' SHEET NO. 7 OF 53 SHEETS STA. 4080+00 TO STA. 4095+00

F.A. RTE.	SECTION	COUNTY	TOTAL SHEETS	SHEET NO.
94	49-1-R-1	LAKE	677	367
CONTRACT NO. 60L77				
ILLINOIS FED. AID PROJECT				

- NOTES**
- SEE SHEET E-12 FOR RUSSELL ROAD LIGHTING
 - SETBACKS ARE MEASURED FROM EDGE OF TRAVELED PAVEMENT TO CENTER OF POLE.

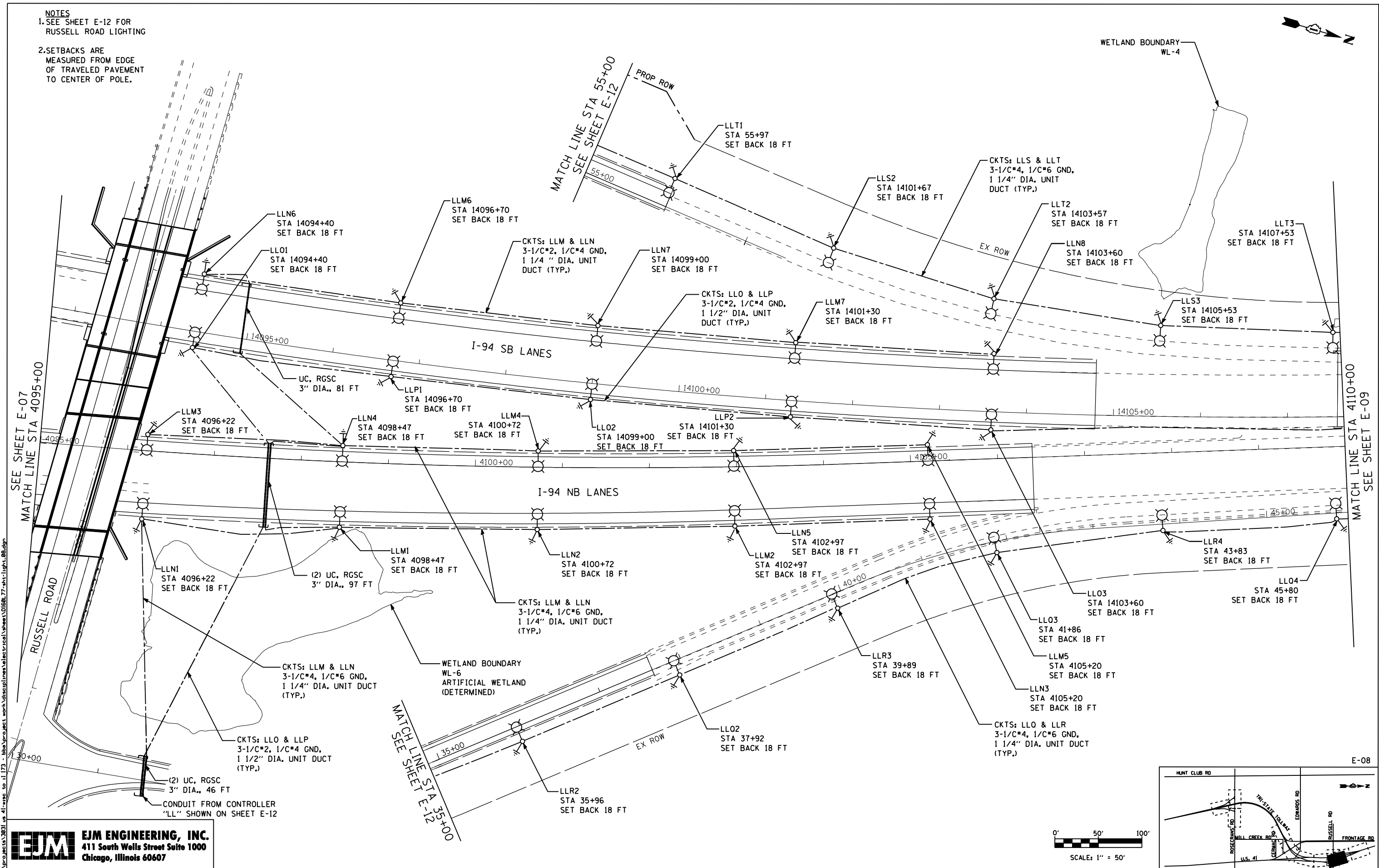

I:\projects\3931\p_41\mss_01173 - bba\project_work\disciplines\electrical\sheet\01666_77-int-light_08.dwg
 6/19/2012 10:41:55 AM

EJM ENGINEERING, INC.
 411 South Wells Street Suite 1000
 Chicago, Illinois 60607

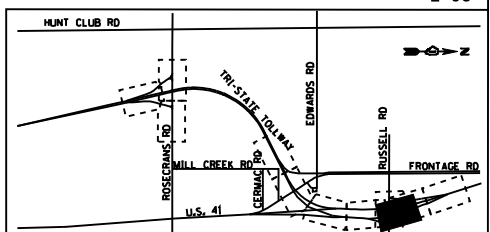
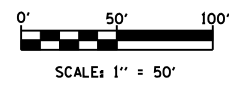

FILE NAME	USER NAME: rsonson	DESIGNED - RAS	REVISED -
		DRAWN - BHH	REVISED -
		CHECKED - MKR	REVISED -
		DATE - 6/19/2012	REVISED -

**STATE OF ILLINOIS
 DEPARTMENT OF TRANSPORTATION**

**PROPOSED IDOT LIGHTING PLAN
 I-94 FROM ROSECRANS RD TO STATE LINE**

SCALE: 1"=50' SHEET NO. 8 OF 53 SHEETS STA. 4095+00 TO STA. 4110+00

F.A. RTE.	SECTION	COUNTY	TOTAL SHEETS	SHEET NO.
94	49-1-R-1	LAKE	677	368
CONTRACT NO. 60L77				
ILLINOIS FED. AID PROJECT				

- NOTES**
- 5 FOUNDATIONS IN MEDIAN ARE EXISTING. INSTALL PROPOSED LIGHT POLES WITH DUAL ARMS ON EXISTING CENTER MEDIAN FOUNDATIONS.
 - INSTALL PROPOSED UNIT DUCT IN EXISTING 4" PVC RACEWAY EMBEDDED IN CENTER MEDIAN.
 - SETBACKS ARE MEASURED FROM EDGE OF TRAVELED PAVEMENT TO CENTER OF POLE.

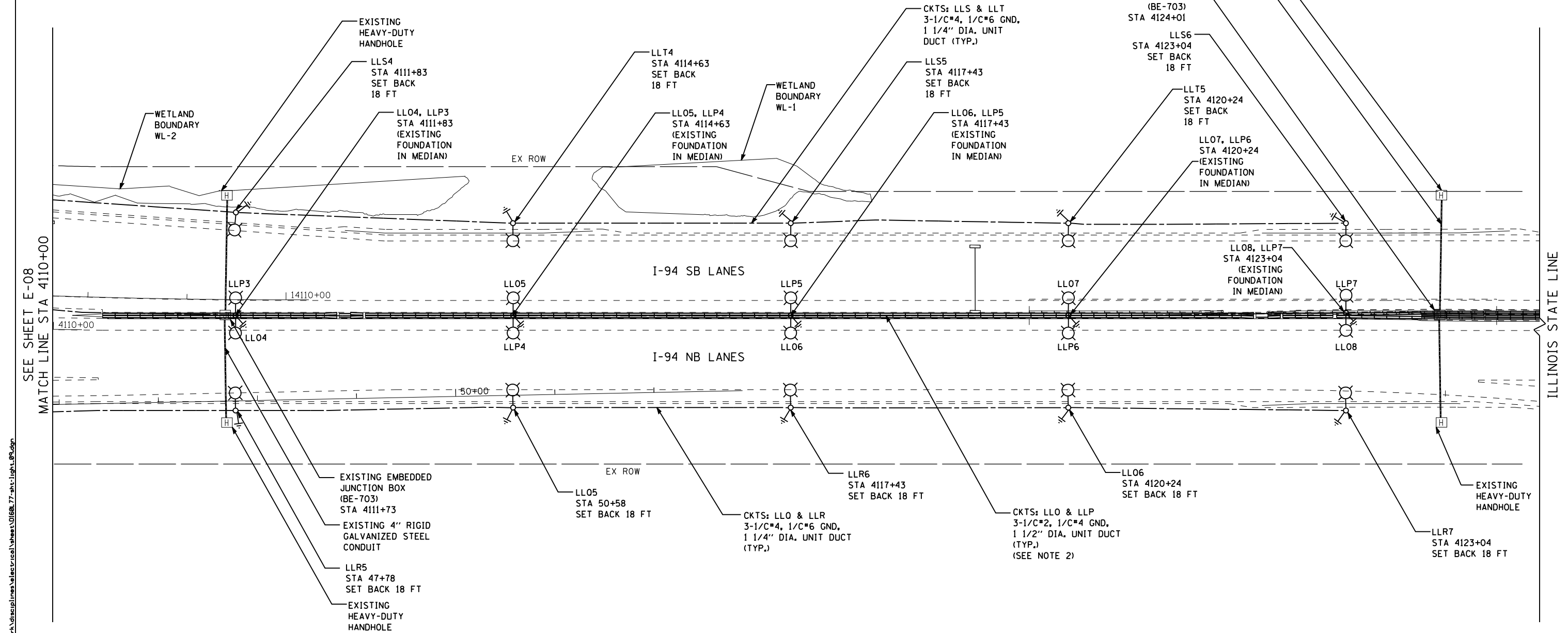

s:\projects\2012\11-173 - bba\proj\set\work\disciplines\electrical\sheet\1173-11-173-light_09.dwg
 4/11/2012 11:41:11 AM to 11/173 - bba\proj\set\work\disciplines\electrical\sheet\1173-11-173-light_09.dwg

EJM ENGINEERING, INC.
 411 South Wells Street Suite 1000
 Chicago, Illinois 60607

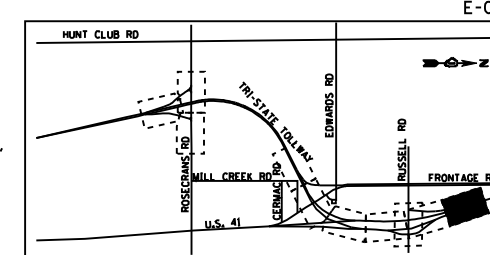
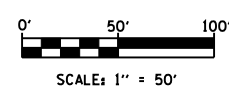

FILE NAME	USER NAME = rsonson	DESIGNED - RAS	REVISED -
		DRAWN - BHH	REVISED -
		CHECKED - MKR	REVISED -
		DATE - 6/19/2012	REVISED -

**STATE OF ILLINOIS
 DEPARTMENT OF TRANSPORTATION**

**PROPOSED IDOT LIGHTING PLAN
 I-94 FROM ROSECRANS RD TO STATE LINE**

SCALE: 1"=50' SHEET NO. 9 OF 53 SHEETS STA. 4110+00 TO STA. 4125+00

F.A. RTE.	SECTION	COUNTY	TOTAL SHEETS	SHEET NO.
94	49-1-R-1	LAKE	677	369
CONTRACT NO. 60L77				
ILLINOIS FED. AID PROJECT				

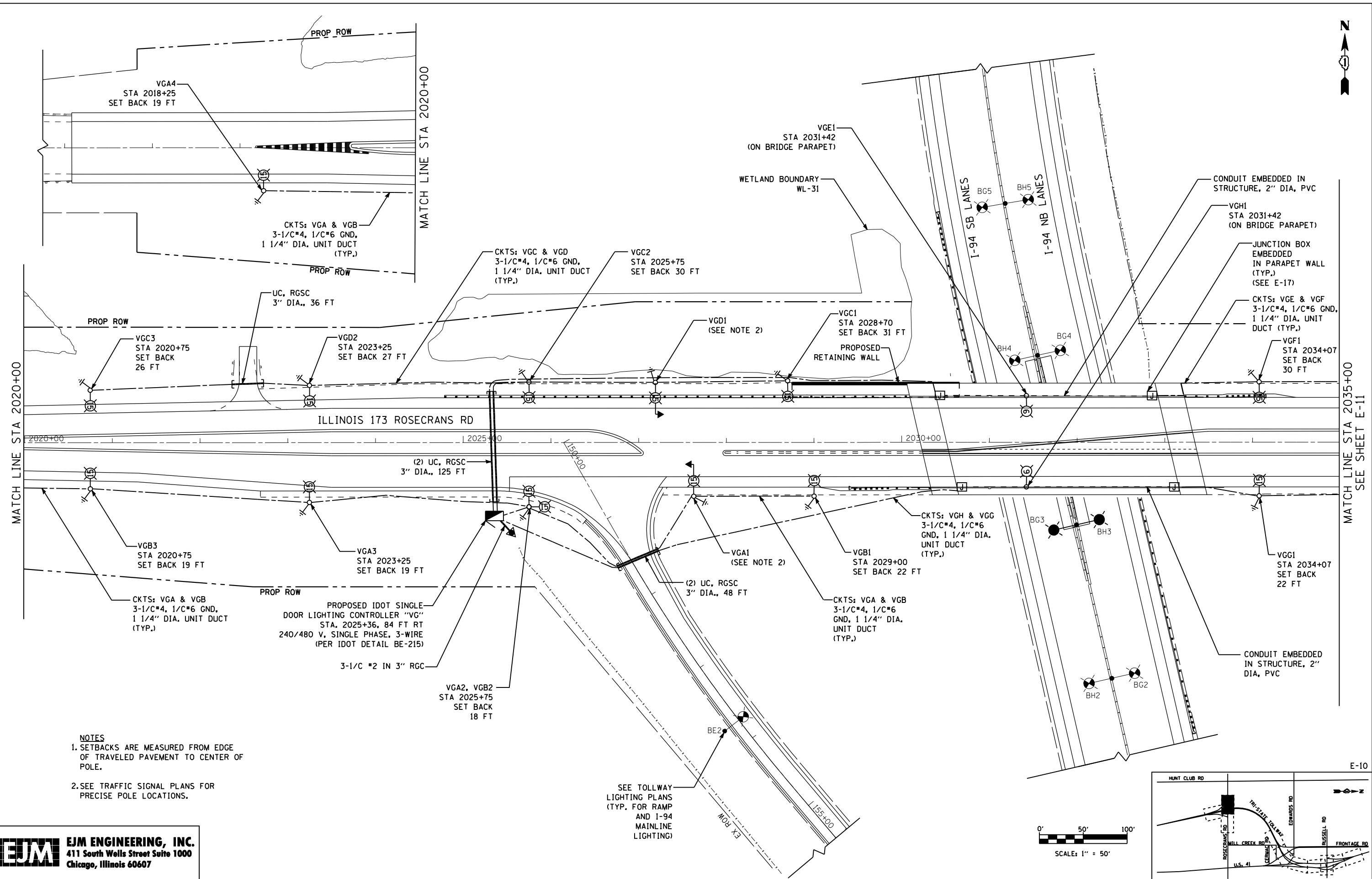

- NOTES**
1. SETBACKS ARE MEASURED FROM EDGE OF TRAVELED PAVEMENT TO CENTER OF POLE.
 2. SEE TRAFFIC SIGNAL PLANS FOR PRECISE POLE LOCATIONS.

SEE TOLLWAY LIGHTING PLANS (TYP. FOR RAMP AND I-94 MAINLINE LIGHTING)

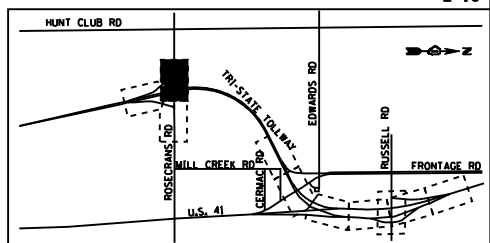
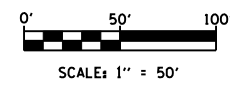

EJM ENGINEERING, INC.
 411 South Wells Street Suite 1000
 Chicago, Illinois 60607

FILE NAME	USER NAME = rsonson	DESIGNED - RAS	REVISED -
		DRAWN - BHH	REVISED -
		CHECKED - MKR	REVISED -
		DATE - 6/19/2012	REVISED -

**STATE OF ILLINOIS
 DEPARTMENT OF TRANSPORTATION**

PROPOSED IDOT LIGHTING PLAN ILLINOIS 173 ROSECRANS RD			
SCALE: 1"=50'	SHEET NO. 10 OF 53 SHEETS	STA. 2020+00 TO STA. 2035+00	

F.A. RTE. 94	SECTION 49-1-R-1	COUNTY LAKE	TOTAL SHEETS 677	SHEET NO. 370
CONTRACT NO. 60L77				
ILLINOIS FED. AID PROJECT				

s:\projects\2012\11-173 - bba\p\set work\disciplines\electrical\sheet\1066-77-11-173.dgn

- NOTES
1. SETBACKS ARE MEASURED FROM EDGE OF TRAVELED PAVEMENT TO CENTER OF POLE.
 2. SEE TRAFFIC SIGNAL PLANS FOR PRECISE POLE LOCATIONS.

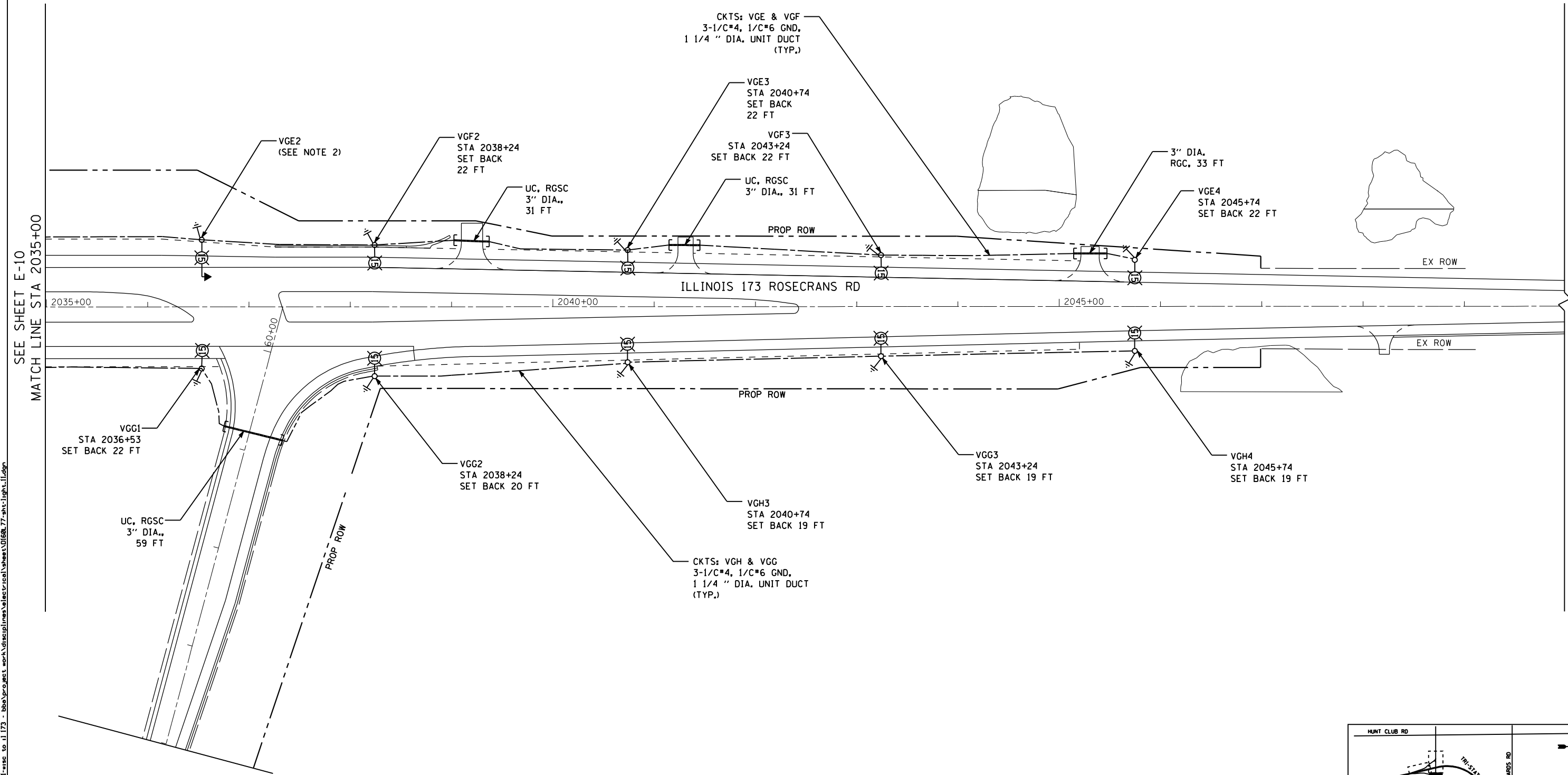

s:\projects\2011 us 41-mse to il 173 - bba\proj\set work\disciplines\electrical\sheet\01666-77-ah-light-11.dgn

EJM ENGINEERING, INC.
 411 South Wells Street Suite 1000
 Chicago, Illinois 60607

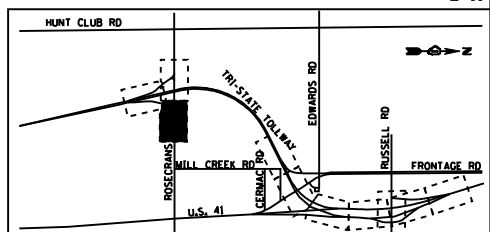
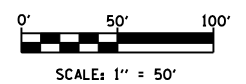

FILE NAME	USER NAME = rsonson	DESIGNED - RAS	REVISED -
		DRAWN - BHH	REVISED -
	PLOT SCALE = 100.0000 / IN.	CHECKED - MKR	REVISED -
	PLOT DATE = 6/18/2012	DATE - 6/19/2012	REVISED -

**STATE OF ILLINOIS
 DEPARTMENT OF TRANSPORTATION**

**PROPOSED IDOT LIGHTING PLAN
 ILLINOIS 173 ROSECRANS RD**

SCALE: 1"=50' SHEET NO. 11 OF 53 SHEETS STA. 2035+00 TO STA. 2050+00

F.A. RTE.	SECTION	COUNTY	TOTAL SHEETS	SHEET NO.
94	49-1-R-1	LAKE	677	371
CONTRACT NO. 60L77				
ILLINOIS FED. AID PROJECT				

E-11

s:\projects\2012\11-173 - bba\proj\set_work\disciplines\electrical\sheet\1173-1173-1173.dgn

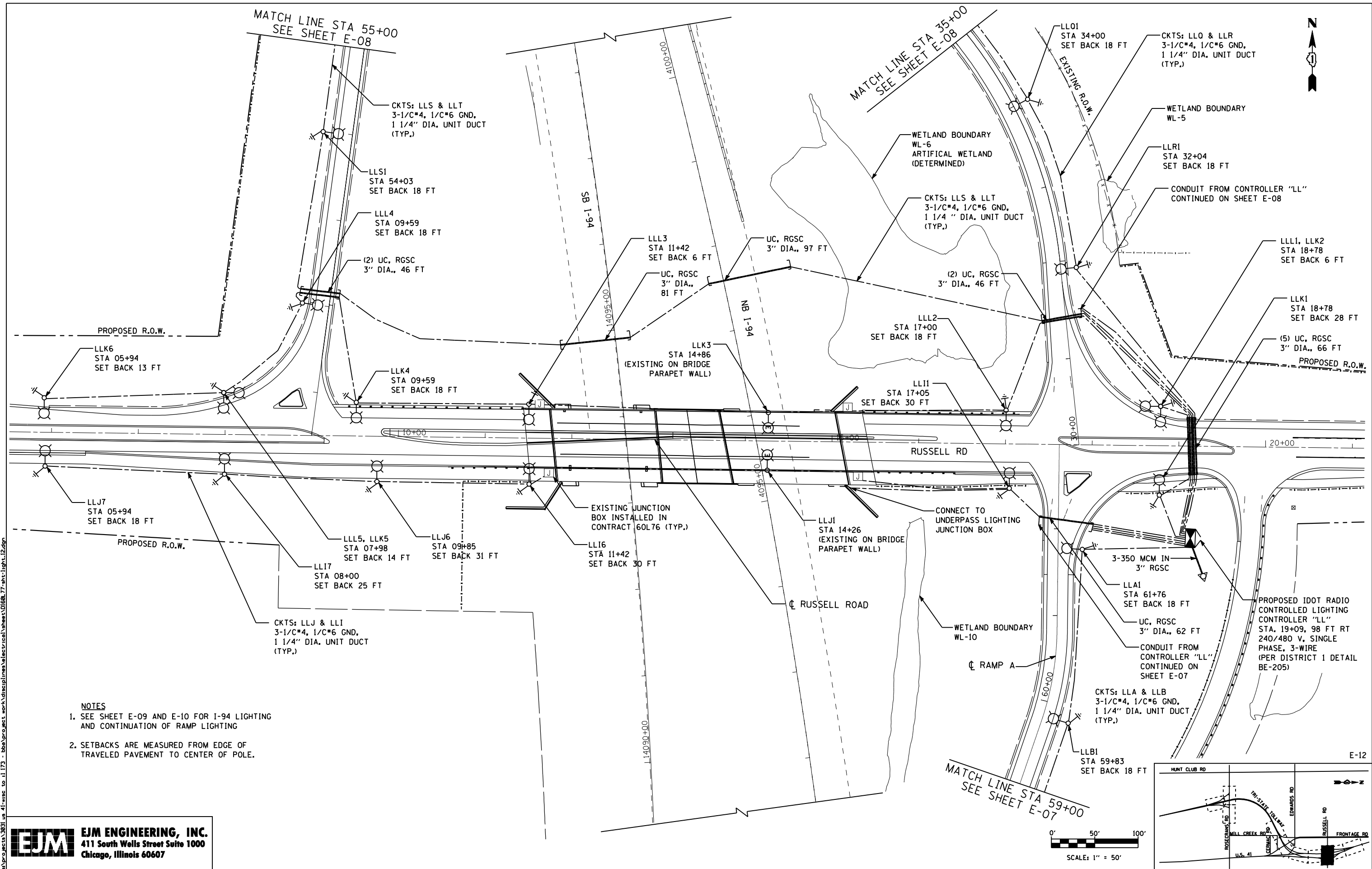

- NOTES**
- SEE SHEET E-09 AND E-10 FOR I-94 LIGHTING AND CONTINUATION OF RAMP LIGHTING
 - SETBACKS ARE MEASURED FROM EDGE OF TRAVELED PAVEMENT TO CENTER OF POLE.

EJM ENGINEERING, INC.
 411 South Wells Street Suite 1000
 Chicago, Illinois 60607

FILE NAME	USER NAME = rsonson	DESIGNED - RAS	REVISED -
		DRAWN - BHH	REVISED -
		CHECKED - MKR	REVISED -
		DATE - 6/19/2012	REVISED -

**STATE OF ILLINOIS
 DEPARTMENT OF TRANSPORTATION**

PROPOSED IDOT LIGHTING PLAN RUSSELL ROAD		
SCALE: 1" = 50'	SHEET NO. 12 OF 53 SHEETS	STA. 4091+52 TO STA. 4100+59

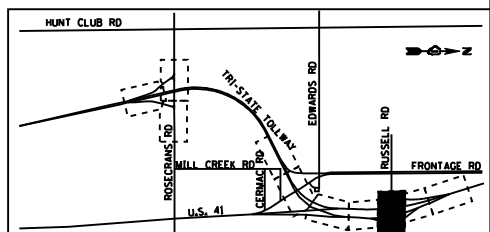

F.A. RTE.	SECTION	COUNTY	TOTAL SHEETS	SHEET NO.
94	49-1-R-1	LAKE	677	372
CONTRACT NO. 60L77				
ILLINOIS FED. AID PROJECT				

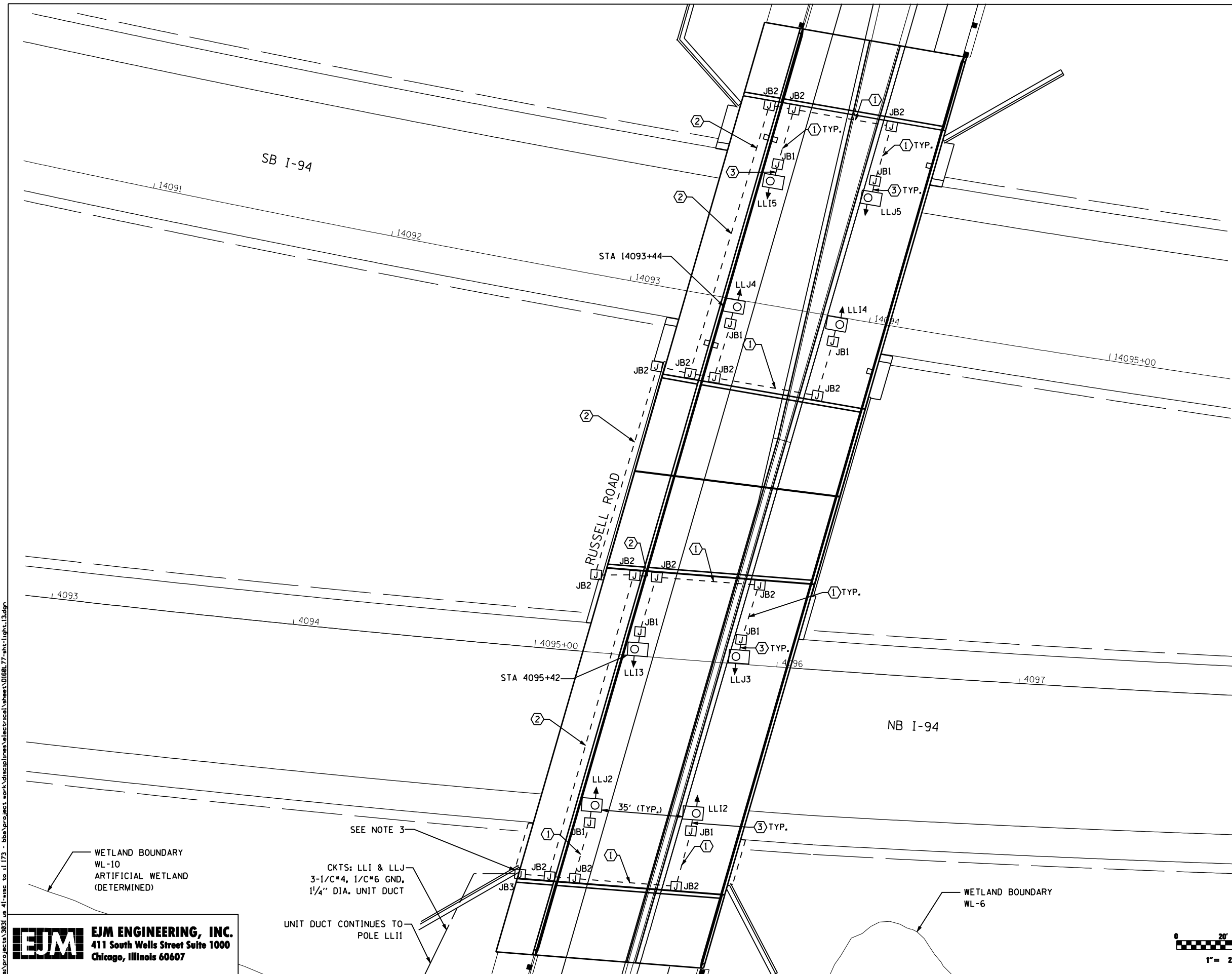

- NOTES:**
- SEE DRAWING E-01 FOR ELECTRICAL SYMBOLS AND ABBREVIATIONS.
 - ALL PROPOSED UNDERPASS LIGHTING UNITS SHOWN ON THIS DRAWING WILL BE FED FROM LIGHT POLE LL11. SEE DRAWING E-15 FOR SINGLE LINE DIAGRAM OF LIGHTING CONTROLLER "LL."
 - PROVIDE 30A FUSES WITH DISCONNECT TYPE FUSE HOLDERS FOR PHASE WIRES AT MAIN JUNCTION BOX. THE COST OF THIS WORK IS INCLUDED IN THE PRICE OF THE JUNCTION BOX.
 - LIQUID TIGHT FLEXIBLE CONDUIT BETWEEN EACH UNDERPASS LUMINAIRE AND THE ADJACENT JUNCTION BOX IS INCLUDED IN THE COST OF THE UNDERPASS LUMINAIRE.
 - SEE SHEET E-29 FOR INSTALLATION DETAILS.
 - ALL UNDERPASS LUMINAIRES AT THIS LOCATION SHALL BE 100 WATT, TYPE IV.
 - PROPOSED UNDERPASS LUMINAIRES SHALL BE INSTALLED AT A 2 FT SETBACK FROM THE EDGE OF TRAVELED WAY.

JUNCTION BOX SCHEDULE		
NO.	SIZE	DESCRIPTION
JB1	6"x6"x4"	STAINLESS STEEL, ATTACHED TO STRUCTURE, UNDERPASS LIGHTING
JB2	12"x10"x6"	STAINLESS STEEL, ATTACHED TO STRUCTURE, UNDERPASS LIGHTING
JB3	16"x14"x6"	STAINLESS STEEL, ATTACHED TO STRUCTURE, UNDERPASS LIGHTING

CABLE /CONDUIT SCHEDULE	
①	2-1/C*10, 1-1/C*10 GND IN 1" DIA PVC RGC ATTACHED TO STRUCTURE (CKTS AS INDICATED ON THIS DRAWING)
②	3-1/C*10, 1-1/C*10 GND IN 1" DIA PVC RGC ATTACHED TO STRUCTURE (CKTS AS INDICATED ON THIS DRAWING)
③	2-1/C*10, 1-1/C*10 GND IN 3/4" DIA LIQUID TIGHT FLEXIBLE CONDUIT (CKTS AS INDICATED ON THIS DRAWING)

s:\projects\3931\041\173 - bba\project_work\disciplines\electrical\sheet\light\13.dwg
 6/18/2012 10:41:55 AM

WETLAND BOUNDARY
WL-10
ARTIFICIAL WETLAND
(DETERMINED)

CKTS: LLI & LLJ
3-1/C*4, 1/C*6 GND,
1/4" DIA. UNIT DUCT

UNIT DUCT CONTINUES TO
POLE LL11

WETLAND BOUNDARY
WL-6

SEE NOTE 3

35' (TYP.)

EJM ENGINEERING, INC.
411 South Wells Street Suite 1000
Chicago, Illinois 60607

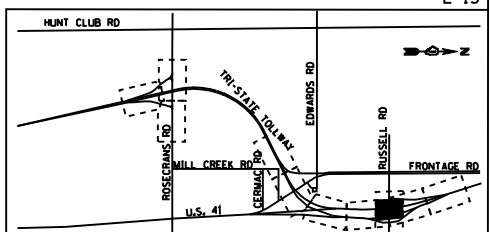
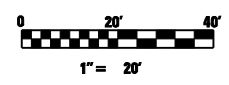

FILE NAME	USER NAME : rsonson	DESIGNED - RAS	REVISED -
		DRAWN - BHH	REVISED -
		CHECKED - MKR	REVISED -
		DATE - 6/19/2012	REVISED -

**STATE OF ILLINOIS
DEPARTMENT OF TRANSPORTATION**

**I-94 AT RUSSELL ROAD
IDOT UNDERPASS LIGHTING PLAN**

SCALE: 1"=20' SHEET NO. 13 OF 53 SHEETS STA. TO STA.

F.A. RTE.	SECTION	COUNTY	TOTAL SHEETS	SHEET NO.
94	49-1-R-1	LAKE	677	373
CONTRACT NO. 60L77				
ILLINOIS FED. AID PROJECT				

E-13

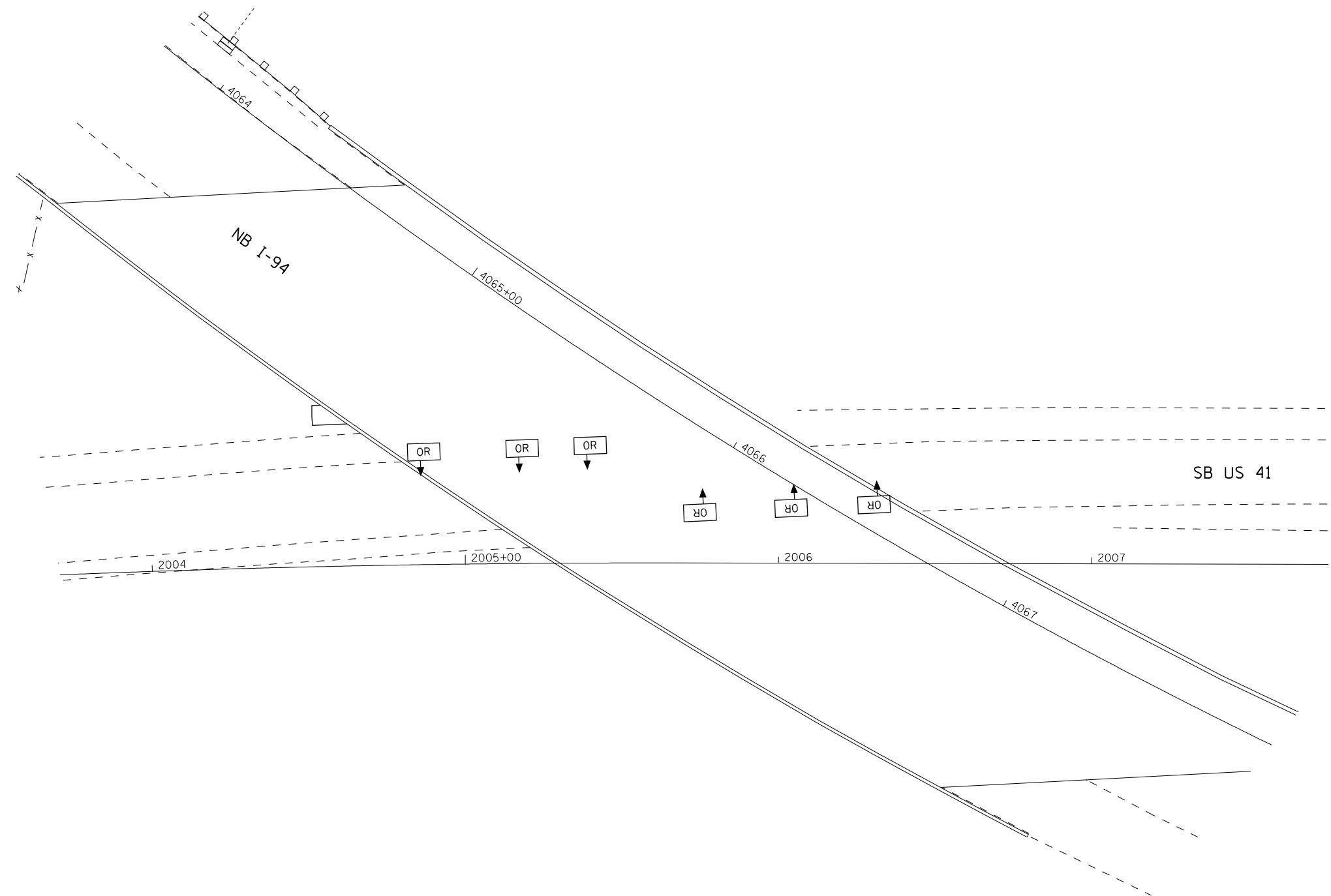

- NOTES:**
1. THE REMOVAL OF EXISTING UNDERPASS LUMINAIRES MUST INCLUDE THE REMOVAL OF ALL CABLES, CONDUIT, JUNCTION BOXES, AND HARDWARE ASSOCIATED WITH THE EXISTING UNDERPASS LIGHTING. THE COST OF THIS WORK WILL NOT BE PAID FOR SEPARATELY, BUT WILL BE INCLUDED AS PART OF THE "REMOVAL OF LIGHTING UNIT, SALVAGE" PAY ITEM.
 2. THE EXISTING UNDERPASS LIGHTING SHALL NOT BE REMOVED UNTIL THE PROPOSED UNDERPASS LIGHTING SYSTEM HAS BEEN ACTIVATED.



SCALE: 1" = 20'

E-13A

s:\projects\2012 us 41-usa to il 173 - bba\project work\disciplines\electrical\sheet\13A.dgn

EJM ENGINEERING, INC.
 411 South Wells Street Suite 1000
 Chicago, Illinois 60607

FILE NAME	USER NAME = rsonson	DESIGNED - RAS	REVISED -
		DRAWN - BHH	REVISED -
	PLOT SCALE = 40.0000' / IN.	CHECKED - MKR	REVISED -
	PLOT DATE = 6/18/2012	DATE - 6/19/2012	REVISED -

**STATE OF ILLINOIS
 DEPARTMENT OF TRANSPORTATION**

**NB I-94 AT SB US 41
 UNDERPASS LIGHTING REMOVAL PLAN**

SCALE: 1"=20' SHEET NO. 13A OF 53 SHEETS STA. TO STA.

F.A. RTE.	SECTION	COUNTY	TOTAL SHEETS	SHEET NO.
94	49-1-R-1	LAKE	677	373A
CONTRACT NO. 60L77			ILLINOIS FED. AID PROJECT	

NOTES:

1. SEE DRAWING E-01 FOR ELECTRICAL SYMBOLS AND ABBREVIATIONS.
2. PROVIDE 30A FUSES WITH DISCONNECT TYPE FUSE HOLDERS FOR PHASE WIRES AT MAIN JUNCTION BOX. THE COST OF THIS WORK IS INCLUDED IN THE PRICE OF THE JUNCTION BOX.
3. LIQUID TIGHT FLEXIBLE CONDUIT BETWEEN EACH UNDERPASS LUMINAIRE AND THE ADJACENT JUNCTION BOX IS INCLUDED IN THE COST OF THE UNDERPASS LUMINAIRE.
4. SEE SHEET E-29 FOR INSTALLATION DETAILS.
5. PROPOSED UNDERPASS LUMINAIRES SHALL BE INSTALLED AT A 2 FT SETBACK FROM THE EDGE OF TRAVELED WAY.
6. ALL UNDERPASS LUMINAIRES AT THIS LOCATION SHALL BE TO WATT, TYPE III.

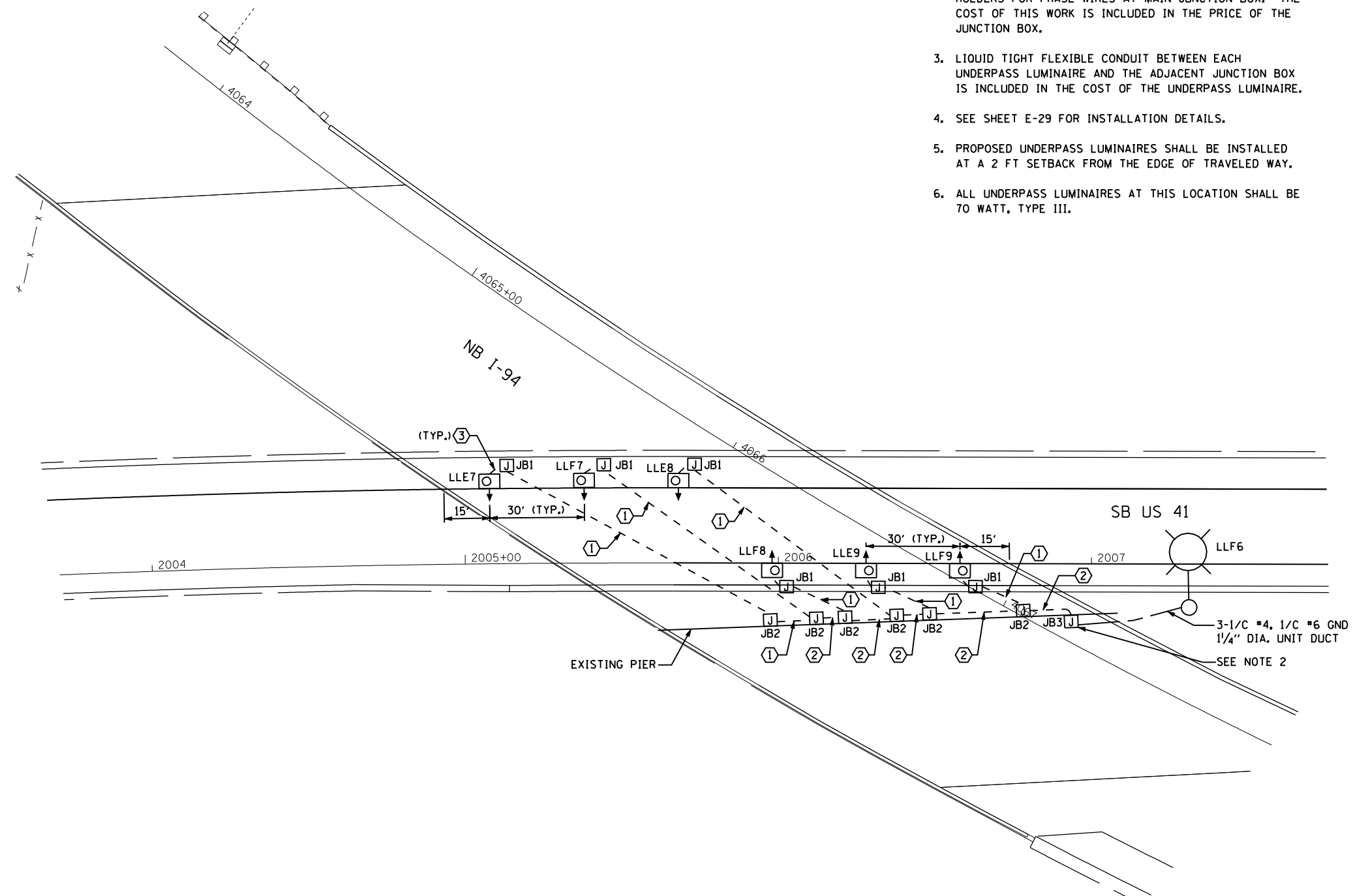

CABLE /CONDUIT SCHEDULE	
①	2-1/C#10, 1-1/C#10 GND IN 1" DIA PVCC RGC ATTACHED TO STRUCTURE (CKTS AS INDICATED ON THIS DRAWING)
②	3-1/C#10, 1-1/C#10 GND IN 1" DIA PVCC RGC ATTACHED TO STRUCTURE (CKTS AS INDICATED ON THIS DRAWING)
③	2-1/C#10, 1-1/C#10 GND IN 3/4" DIA LIQUID TIGHT FLEXIBLE CONDUIT (CKTS AS INDICATED ON THIS DRAWING)

JUNCTION BOX SCHEDULE		
NO.	SIZE	DESCRIPTION
JB1	6"x6"x4"	STAINLESS STEEL, ATTACHED TO STRUCTURE, UNDERPASS LIGHTING
JB2	12"x10"x6"	STAINLESS STEEL, ATTACHED TO STRUCTURE, UNDERPASS LIGHTING
JB3	16"x14"x6"	STAINLESS STEEL, ATTACHED TO STRUCTURE, UNDERPASS LIGHTING

EJM ENGINEERING, INC.
 411 South Wells Street Suite 1000
 Chicago, Illinois 60607



FILE NAME	USER NAME = rsonson	DESIGNED - RAS	REVISED -
		DRAWN - BHH	REVISED -
	PLOT SCALE = 40.0000' / IN.	CHECKED - MKR	REVISED -
	PLOT DATE = 6/18/2012	DATE - 6/19/2012	REVISED -

**STATE OF ILLINOIS
 DEPARTMENT OF TRANSPORTATION**

**NB I-94 AT SB US 41
 IDOT UNDERPASS LIGHTING PLAN**

SCALE: 1"=20' SHEET NO. 14 OF 53 SHEETS STA. TO STA.

F.A. RTE.	SECTION	COUNTY	TOTAL SHEETS	SHEET NO.
94	49-1-R-1	LAKE	677	374
CONTRACT NO. 60L77				
ILLINOIS FED. AID PROJECT				

s:\projects\3031 us 41-usa to il 173 - bba\proj\set work\disciplines\electrical\sheet\11186-77-sh-11ght-14.dgn



**LOAD TABLE
LIGHTING CONTROLLER "LL"
(@ 240 VOLT)**

CIRCUIT	RED PHASE (RED CABLE)		CIRCUIT	BLACK PHASE (BLACK CABLE)	
	AMPS	WATTS		AMPS	WATTS
A	16	3840	B	14	3360
C	12	2880	D	10	2400
E	13.2	3168	F	13.2	3168
G	10	2400	H	12	2880
I	8.2	1960	J	8.2	1960
K	12	2880	L	12	2880
M	14	3360	N	16	3840
O	16	3840	P	14	3360
O	12	2880	R	14	3360
S	12	2880	T	10	2400
U			V		
TOTAL	125.4	30088	TOTAL	123.4	29608

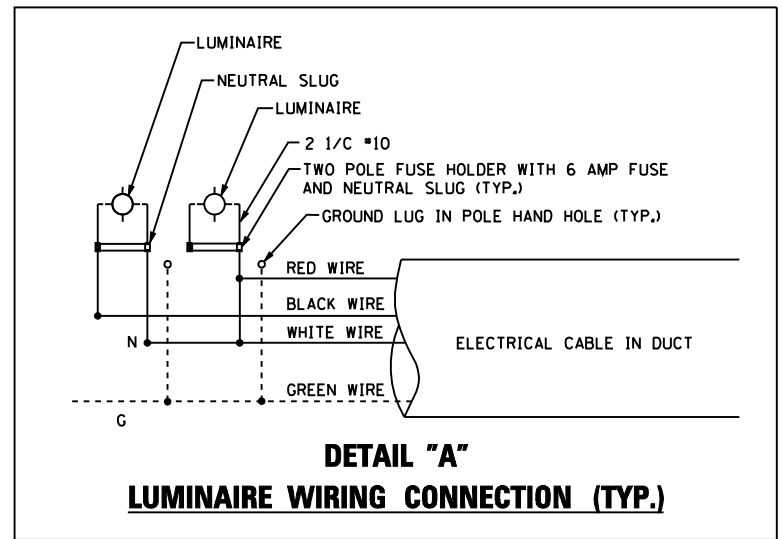
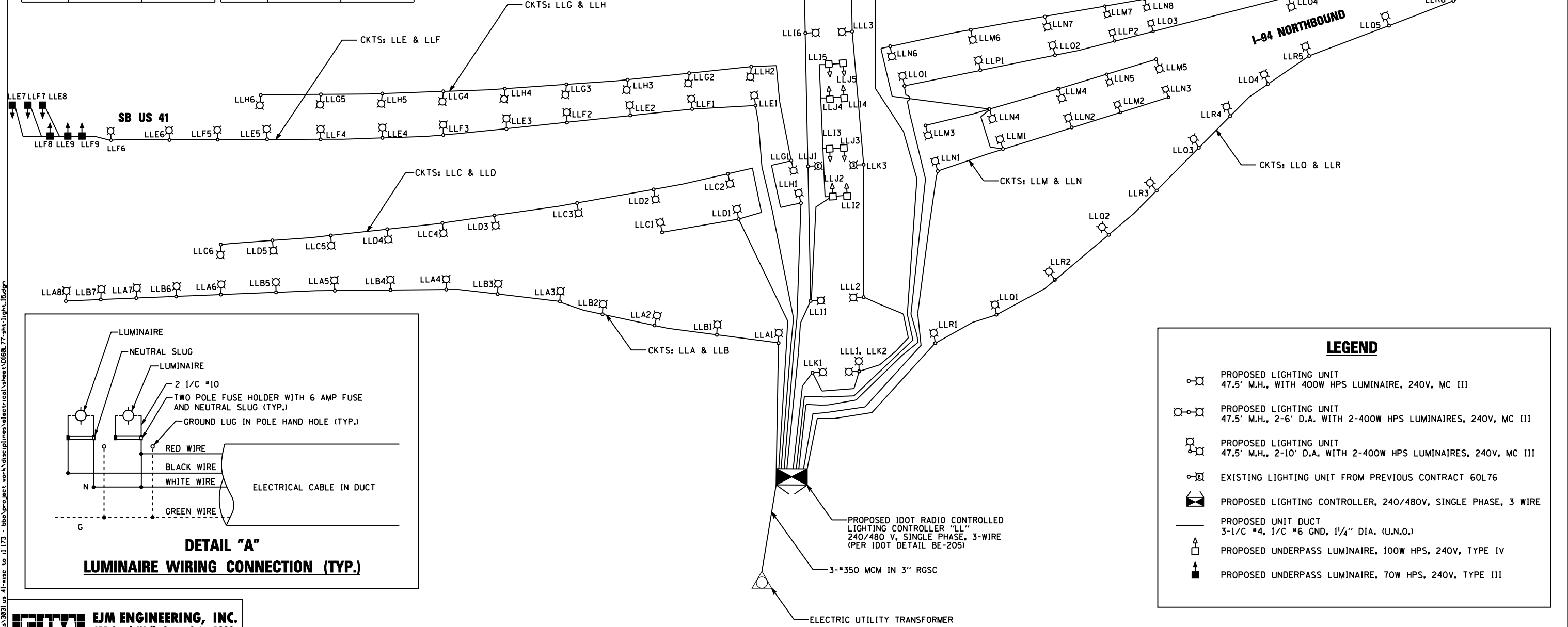

LEGEND

- PROPOSED LIGHTING UNIT
47.5' M.H., WITH 400W HPS LUMINAIRE, 240V, MC III
- PROPOSED LIGHTING UNIT
47.5' M.H., 2-6' D.A. WITH 2-400W HPS LUMINAIRE, 240V, MC III
- PROPOSED LIGHTING UNIT
47.5' M.H., 2-10' D.A. WITH 2-400W HPS LUMINAIRE, 240V, MC III
- EXISTING LIGHTING UNIT FROM PREVIOUS CONTRACT 60L76
- PROPOSED LIGHTING CONTROLLER, 240/480V, SINGLE PHASE, 3 WIRE
- PROPOSED UNIT DUCT
3-1/C #4, 1/C #6 GND, 1 1/4" DIA. (U.N.O.)
- PROPOSED UNDERPASS LUMINAIRE, 100W HPS, 240V, TYPE IV
- PROPOSED UNDERPASS LUMINAIRE, 70W HPS, 240V, TYPE III

EJM ENGINEERING, INC.
411 South Wells Street Suite 1000
Chicago, Illinois 60607

FILE NAME	USER NAME = rsonson	DESIGNED - RAS	REVISED -
		DRAWN - BHH	REVISED -
		CHECKED - MKR	REVISED -
		DATE - 6/19/2012	REVISED -

**STATE OF ILLINOIS
DEPARTMENT OF TRANSPORTATION**

**I-94 FROM ROSECRANS RD TO STATE LINE
SINGLE LINE DIAGRAM - IDOT CONTROLLER "LL"**

SCALE: NONE SHEET NO. 15 OF 53 SHEETS STA. TO STA.

F.A. RTE.	SECTION	COUNTY	TOTAL SHEETS	SHEET NO.
94	49-1-R-1	LAKE	677	375
CONTRACT NO. 60L77				
ILLINOIS FED. AID PROJECT				



LOAD TABLE PROPOSED LIGHTING CONTROLLER "VG" (@ 240 VOLT)					
CIRCUIT	RED PHASE (RED CABLE)		CIRCUIT	BLACK PHASE (BLACK CABLE)	
	AMPS	WATTS		AMPS	WATTS
A	8	1920	B	6	1440
C	6	1440	D	4	960
E	8	1920	F	6	1440
G	6	1440	H	8	1920
TOTAL	28	6720	TOTAL	24	5760

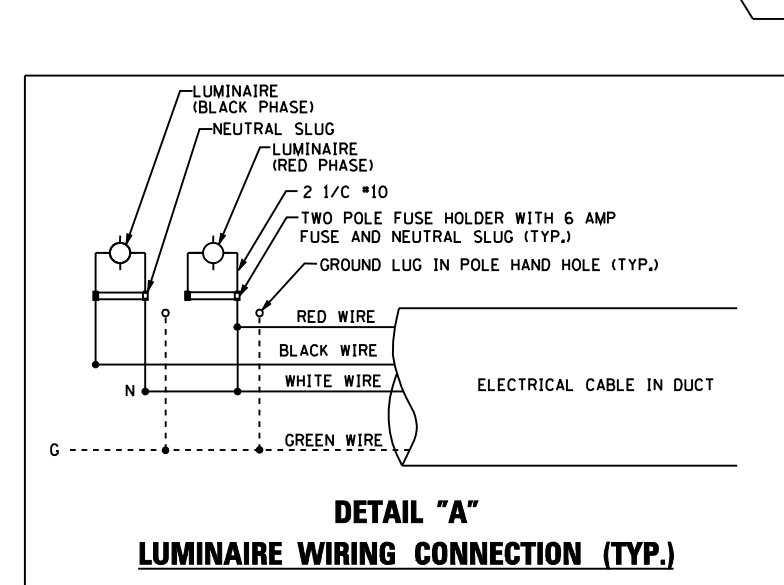
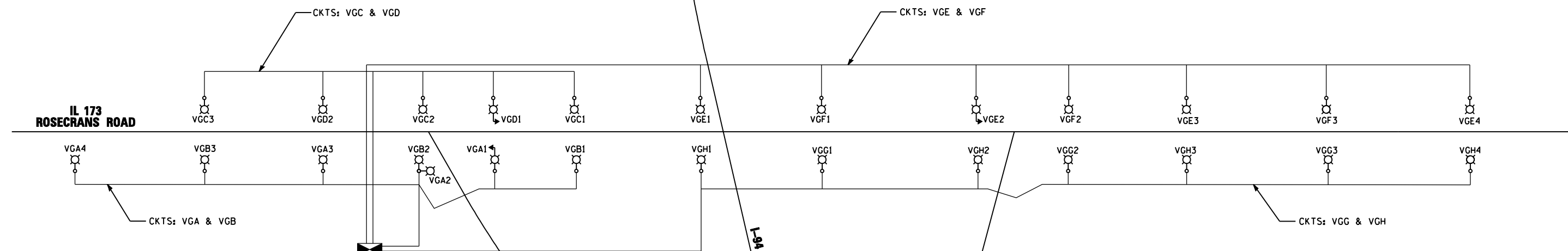

PROPOSED IDOT LIGHTING CONTROLLER "VG" 240/480V, SINGLE PHASE, 3-WIRE NON-RADIO SINGLE DOOR CABINET (PER IDOT DETAIL BE-215)

LEGEND	
	PROPOSED LIGHTING UNIT ON COMBINATION TRAFFIC SIGNAL POLE 45' M.H., WITH 400W HPS LUMINAIRE, 240V, MCIII
	PROPOSED LIGHTING UNIT 47.5' M.H., 2-15' D.A. WITH 2-400W HPS LUMINAIRES, 240V, MC III
	PROPOSED LIGHTING UNIT 47.5' M.H., WITH 400W HPS LUMINAIRE, 240V, MC III
	PROPOSED LIGHTING CONTROLLER, 240/480V, 1 PHASE, 3 WIRE
	PROPOSED UNIT DUCT 1 1/4" DIAMETER, 3-1/2" #4, 1/2" #6 GROUND

EJM ENGINEERING, INC.
411 South Wells Street Suite 1000
Chicago, Illinois 60607

FILE NAME	USER NAME = rsonson	DESIGNED - RAS	REVISED -
		DRAWN - BHH	REVISED -
		CHECKED - MKR	REVISED -
		DATE - 6/19/2012	REVISED -

STATE OF ILLINOIS
DEPARTMENT OF TRANSPORTATION

ROSECRANS RD SINGLE LINE DIAGRAM - IDOT CONTROLLER "VG"			
SCALE: NONE	SHEET NO. 16 OF 53 SHEETS	STA.	TO STA.

F.A. RTE.	SECTION	COUNTY	TOTAL SHEETS	SHEET NO.
94	49-1-R-1	LAKE	677	376
CONTRACT NO. 60L77				
ILLINOIS FED. AID PROJECT				

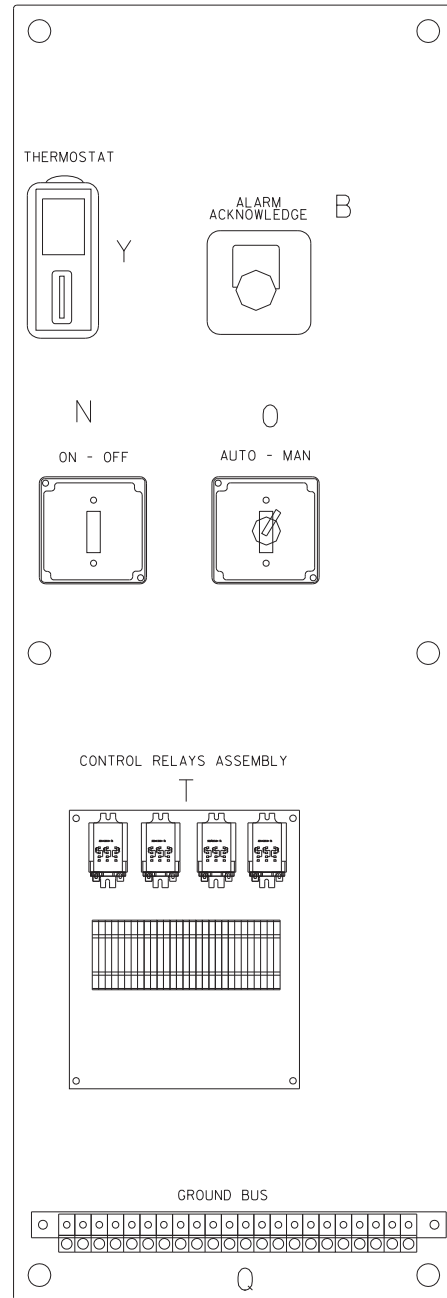
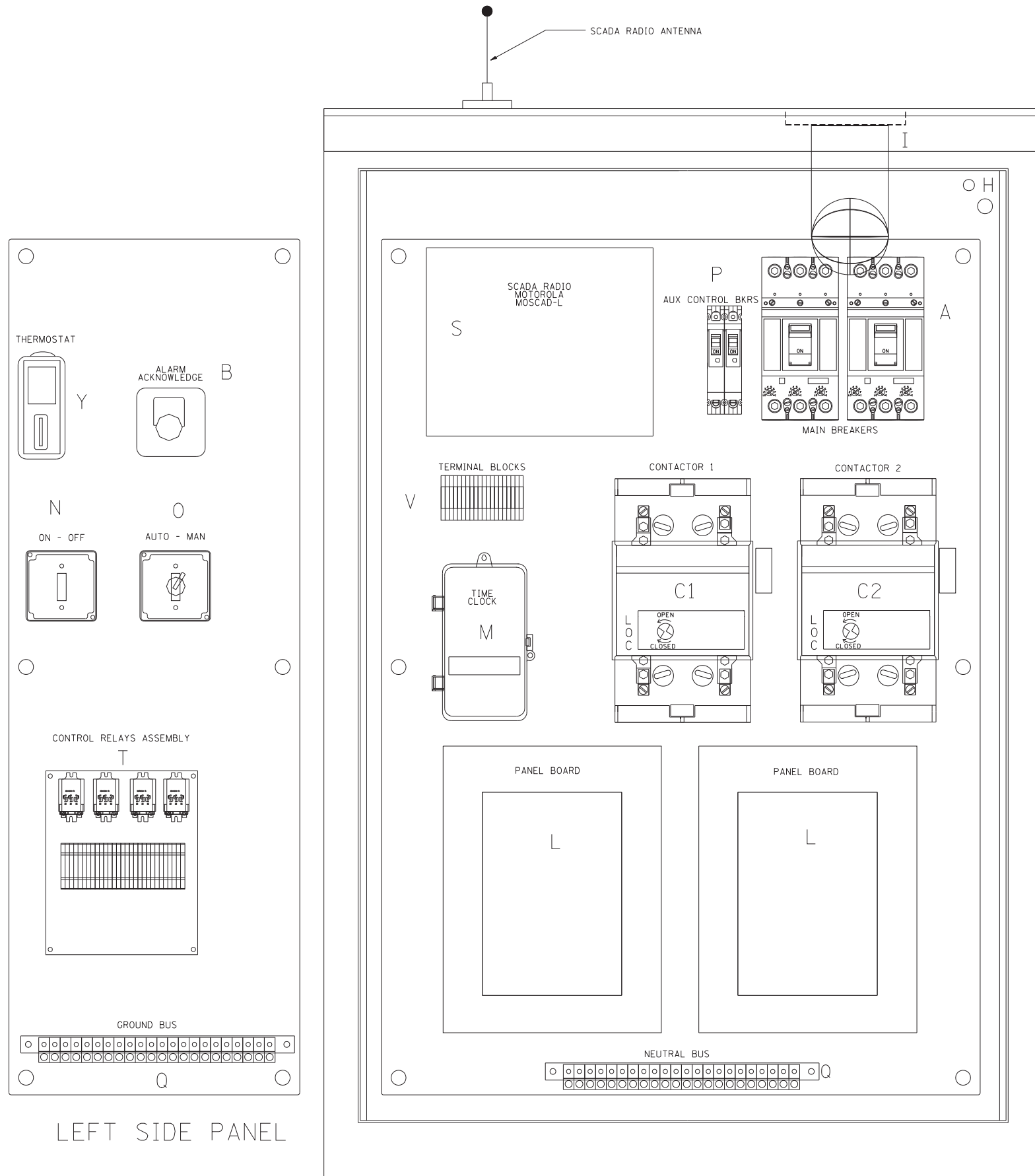

LEFT SIDE PANEL

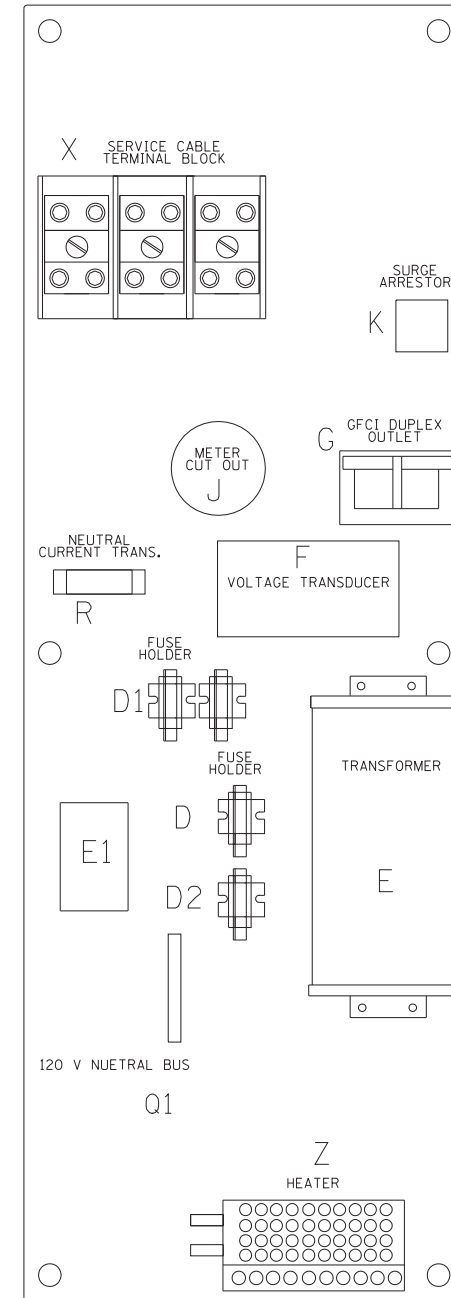

RIGHT SIDE PANEL

BILL OF MATERIALS		
ITEM	QTY	DESCRIPTION
A	2	MAIN CIRCUIT BREAKERS 2 POLE 175 AMP WITH AUX CONTACT
B	1	ACKNOWLEDGE SWITCH, PUSH BUTTON WITH YELLOW INSERT
C1, C2 *	2	CONTACTOR 2 POLE 200 AMP 240V COIL WITH AUX CONTACTS
D	1	FINGERSAFE FUSE HOLDER WITH KTK-20 FUSE
D1	2	FINGERSAFE FUSE HOLDER WITH KTK-1/2 FUSE
D2	1	FINGERSAFE FUSE HOLDER WITH KTK-2A FUSE
E	1	2.0 KVA 277V-240/120 TRANSFORMER
E1	1	0.25 KVA 240/120 - 24 VAC TRANSFORMER
F	1	VOLTAGE TRANSDUCER WITH COVERED TERMINALS
G	1	20 AMP GFCI DUPLEX OUTLET W/COVER
H	2	DOOR SWITCH
I	1	LIGHT FIXTURE
J	1	METER FITTING 1 PHASE 3 WIRE 200 AMP
K	1	SURGE ARRESTER
L	2	PANEL BOARD 480/240V 1 PHASE, 250 AMP COPPER BUS
M	1	2 CHANNEL DIGITAL TIME CLOCK
N	1	MOMENTARY SWITCH ON - OFF
O	1	SQUARE D, 9001KS11BH13, 2 POSITION SWITCH IN 9001KY1 ENCLOSURE OR APPROVED EQUAL
P	2	BREAKER 1P 15A
Q	2	COPPER GROUND AND NEUTRAL BUS 1 x 16 x 1/4
Q1	1	COPPER NEUTRAL BUS WITH 1 #6 AND 8 #12 CONDUCTOR POINTS
R	1	CURRENT TRANSDUCER
S	1	MOTOROLA MOSCAD-L RADIO, 240 V
T *	1	CONTROL RELAY ASSEMBLY 240V COILS WITH 4 3 PDT 25A RELAYS (W389ACX-15) (R1, R2, R3, R4) . QTY 32 TERMINAL BLOCKS
V	20	TERMINAL BLOCKS
X *	1	620 AMP SLIPICE BLOCK
Y	1	40-80 DEG THERMOSTAT
Z	1	375 WATT HEATER

* TERMINALS SHALL BE COVERED WITH CLEAR PLEXIGLASS SHEET

FILE NAME =	USER NAME = drivakosgn	DESIGNED -	REVISED - R. TOMSONS 08-19-04
ct:\pwwork\pwidot\DRIVAKOSGN\d0108315\be205.dgn		DRAWN -	REVISED - R. TOMSONS 05-11-09
		CHECKED -	REVISED -
		DATE -	REVISED -

STATE OF ILLINOIS
DEPARTMENT OF TRANSPORTATION

LIGHTING CONTROLLER, RADIO CONTROL
DUPLIX TYPE WITH SCADA

SCALE: NONE SHEET NO. 18 OF 53 SHEETS STA. TO STA.

F.A. RTE.	SECTION	COUNTY	TOTAL SHEETS	SHEET NO.
94	49-1-R-1	LAKE	677	378
BE-205			CONTRACT NO. 60L77	
FED. ROAD DIST. NO. 1 ILLINOIS FED. AID PROJECT				

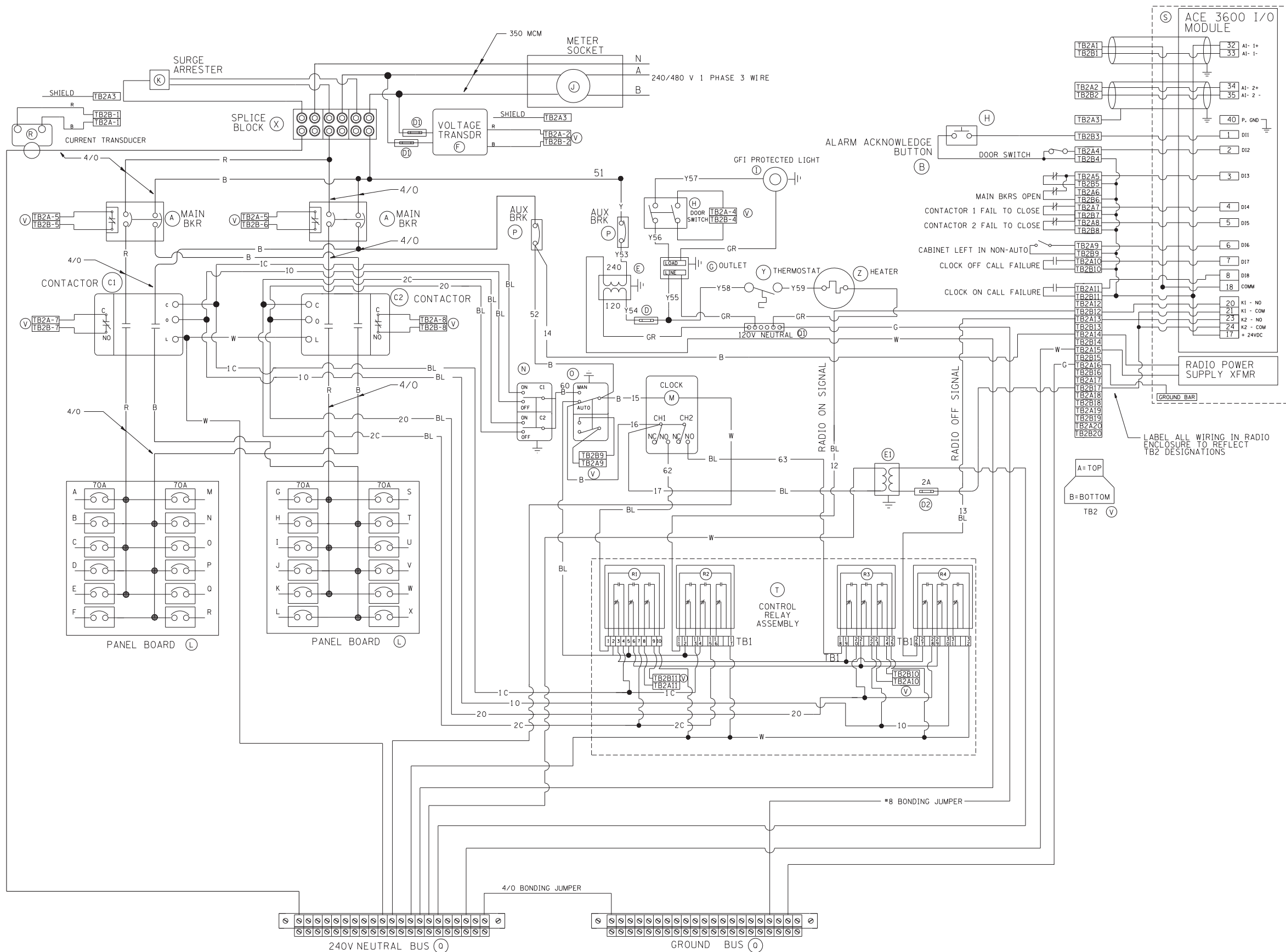

BILL OF MATERIALS		
ITEM #	QTY	DESCRIPTION
A	2	MAIN CIRCUIT BREAKERS 2 POLE 175 AMP WITH AUX CONTACT
B	1	ACKNOWLEDGE SWITCH, PUSH BUTTON WITH YELLOW INSERT
C1, C2	2	CONTACTOR 2 POLE 200 AMP 240V COIL WITH AUX CONTACTS
D	1	FINGERSAFE FUSE HOLDER WITH KTK-20A FUSE
D1	2	FINGERSAFE FUSE HOLDER WITH KTK-1/2 FUSE
D2	1	FINGERSAFE FUSE HOLDER WITH KTK- 2A FUSE
E	1	2.0 KVA 277V-240/120 TRANSFORMER
E1	1	0.25 KVA 240/120-24 VAC TRANSFORMER
F	1	VOLTAGE TRANSDUCER
G	1	15 AMP GFCI DUPLEX OUTLET W/COVER
H	2	DOOR SWITCH A-20G0-B7-K
I	1	LIGHT FIXTURE
J	1	METER FITTING 1 PHASE 3 WIRE 200 AMP
K	1	SURGE ARRESTER
L	2	PANEL BOARD 480/240V 1 PHASE, 250 AMP COPPER BUS
M	1	2 CHANNEL DIGITAL TIME CLOCK
N	1	MOMENTARY SWITCH ON - OFF
O	1	SQUARE D, 900IKS1BH13, 2 POSITION SWITCH IN 900IKY1 ENCLOSURE
P	2	BREAKER IP 15A
Q	2	COPPER GROUND AND NEUTRAL BUS 1 x 16 x 1/4
Q1	1	COPPER NEUTRAL BUS WITH 1 1/0 AND *6 CONDUCTOR POINTS
R	1	CURRENT TRANSDUCER
S	1	MOTOROLA ACE 3600
T	1	CONTROL RELAY ASSEMBLY 240V COILS WITH 4 3 PDT 25A RELAYS (W389ACX-15) (R1, R2, R3, R4) . QTY 32
V	20	TERMINAL BLOCKS
X	1	620 AMP SPLICE BLOCK
Y	1	40-80 DEG THERMOSTAT
Z	1	375 WATT HEATER

FILE NAME = USER NAME = drivakosgn
 DESIGNED - R. TOMSONS 08-19-04
 DRAWN - R. TOMSONS 05-11-09
 PLOT SCALE = 50.000' / IN.
 CHECKED -
 DATE -

**STATE OF ILLINOIS
DEPARTMENT OF TRANSPORTATION**

**LIGHTING CONTROLLER, RADIO CONTROL
DUPLIX TYPE WITH SCADA**

SCALE: NONE SHEET NO. 19 OF 53 SHEETS STA. TO STA.

F.A. RFE.	SECTION	COUNTY	TOTAL SHEETS	SHEET NO.
94	49-1-R-1	LAKE	677	379
BE-205		CONTRACT NO. 60L77		
FED. ROAD DIST. NO. 1 ILLINOIS FED. AID PROJECT				

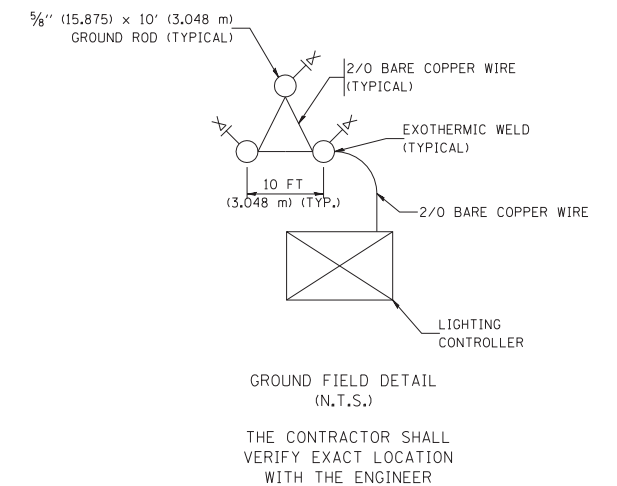
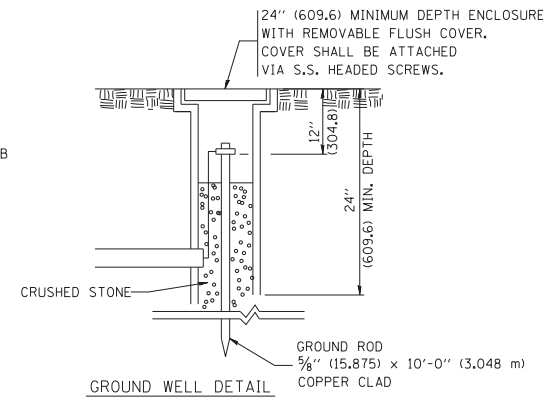
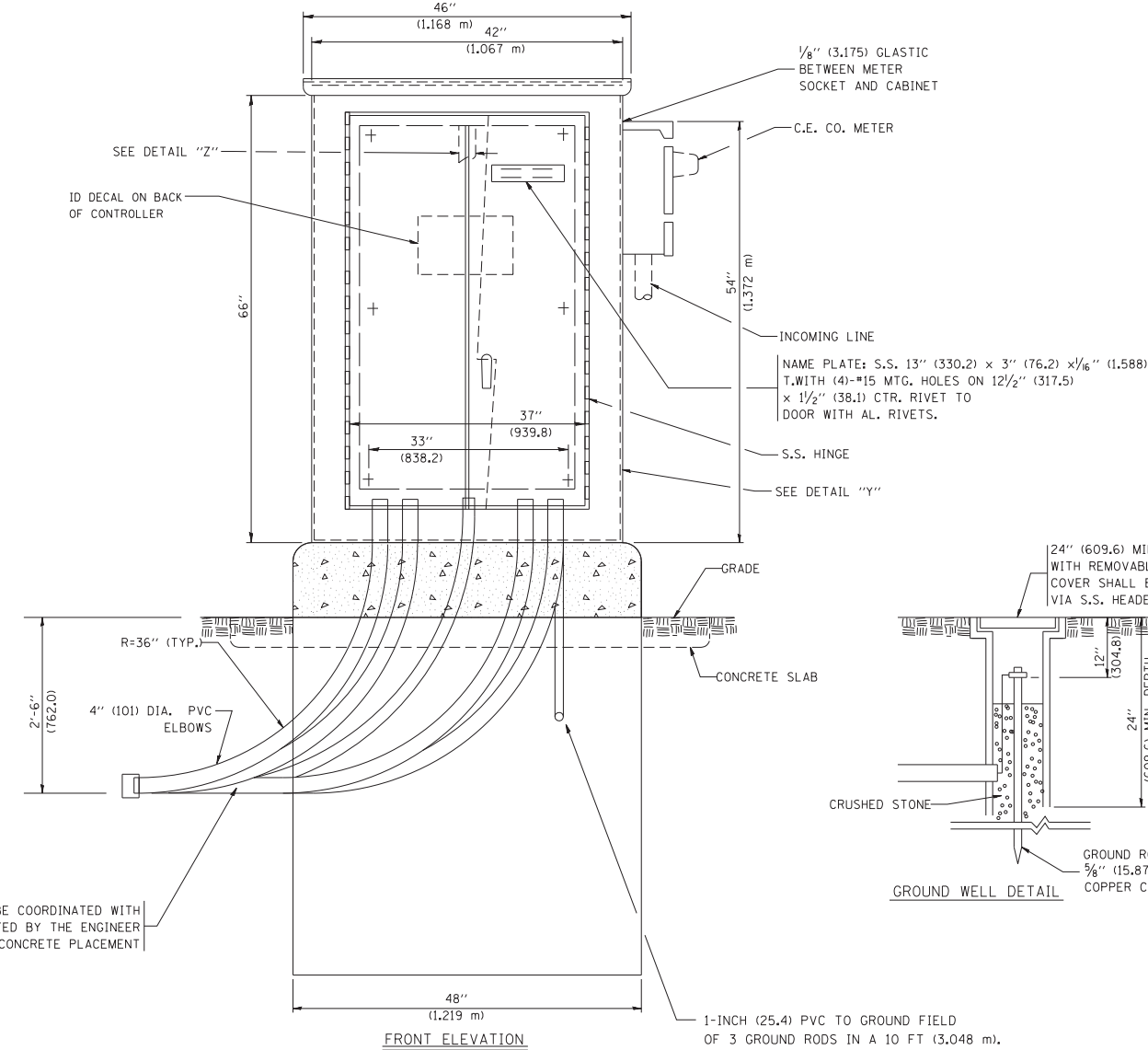
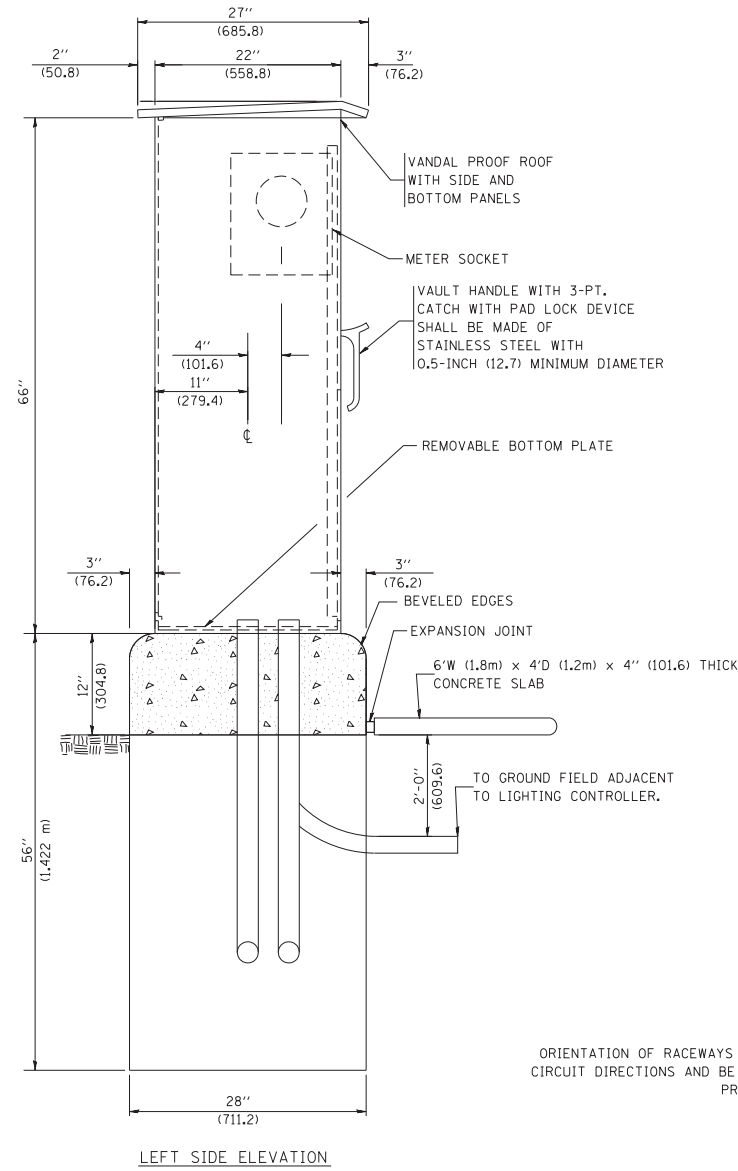
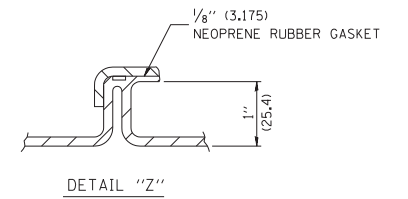
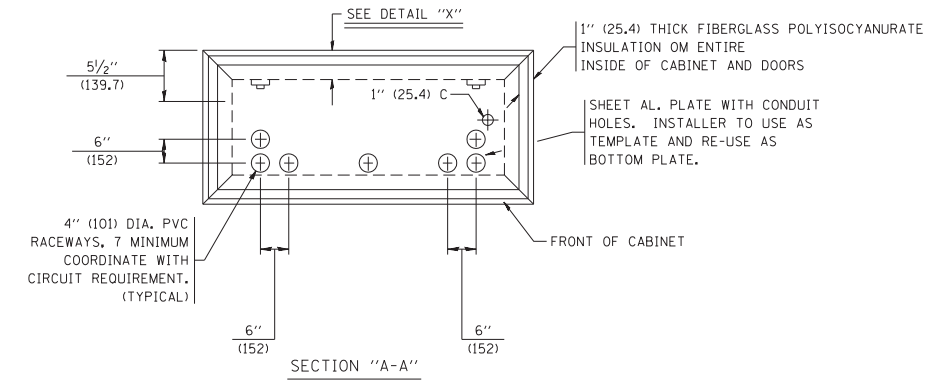
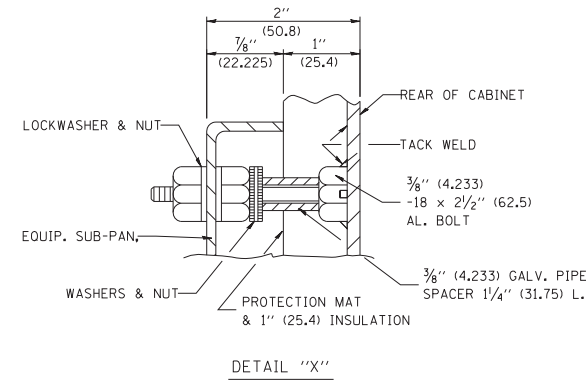
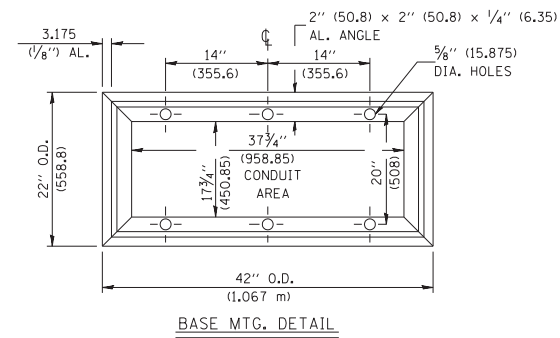
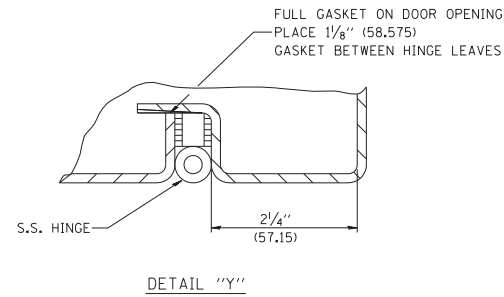

ORIENTATION OF RACEWAYS SHALL BE COORDINATED WITH CIRCUIT DIRECTIONS AND BE INSPECTED BY THE ENGINEER PRIOR TO CONCRETE PLACEMENT

1-INCH (25.4) PVC TO GROUND FIELD OF 3 GROUND RODS IN A 10 FT (3,048 m). TRIANGLE CONNECTED VIA BARE COPPER WIRE. VERIFY EXACT LOCATION OF GROUND FIELD WITH THE ENGINEER. NO GROUND WELL SHALL BE PLACED IN CONCRETE PAD IN FRONT OF CONTROLLER.

FILE NAME =	USER NAME = drivakosgn	DESIGNED -	REVISED - R. TOMSONS 08-19-04
c:\pwwork\pwwid\DRIVAKOSGN\d108315\be205.dgn		DRAWN -	REVISED - R. TOMSONS 05-11-09
		PLOT SCALE = 50.000' / IN.	REVISED -
		PLOT DATE = 5/11/2009	REVISED -

STATE OF ILLINOIS
DEPARTMENT OF TRANSPORTATION

LIGHTING CONTROLLER, RADIO CONTROL
DUPLIX TYPE WITH SCADA

SCALE: NONE SHEET NO. 20 OF 53 SHEETS STA. TO STA.

F.A. RTE.	SECTION	COUNTY	TOTAL SHEETS	SHEET NO.
94	49-1-R-1	LAKE	677	380
BE-205		CONTRACT NO. 60L77		
FED. ROAD DIST. NO. 1 ILLINOIS FED. AID PROJECT				

NOTES

- CABINET SHALL BE FABRICATED FROM 0.125-INCH (3.175) SHEET ALUMINUM #3003H14, FORMED AND ARC WELDED.
- ALL SCREWS AND HARDWARE SHALL BE PLATED, GALVANIZED, OR MADE OF BRASS, ALUMINUM OR STAINLESS STEEL, UNLESS OTHERWISE NOTED.
- NAME PLATE SHALL HAVE ENGRAVED 0.75-INCH (19.05) HIGH LETTERS FILLED IN BLACK: "STATE OF ILLINOIS LIGHTING CONTROLS" UNLESS OTHERWISE SPECIFIED.
- ONE INCH THICK POLYISOCYANURATE INSULATION SHALL BE INSTALL AND PERMANENTLY CEMENTED ON ALL SIDES OF THE CABINET AND DOORS.
- CABINET SHALL BE PRIMED AND PAINTED AS SPECIFIED.
- ELECTRIC UTILITY METER BOX SHALL BE MOUNTED ON THE SIDE OF CONTROL CABINET AS SHOWN ON THE PANEL LAYOUT DIAGRAM.
- THE COMPLETED CONTROLLER SHALL BE U.L. LISTED AS AN INDUSTRIAL CONTROL PANEL UNDER UL508.
- METAL MOUNTING PANEL SHALL BE FABRICATED FROM THE SAME MATERIAL AS THE CABINET AND SHALL BE FLANGED BACK 0.75-INCHES I.D. ON 4 SIDES.
- CIRCUIT BREAKERS AND CONTACTORS AND OTHER COMPONENTS SHALL BE MOUNTED ON 0.125-INCH (3.175) THICK GLASTIC INSULATION BACK PANEL.
- ALL DEVICES SHALL BE FRONT REMOVABLE.
- TIME CLOCK CHANNEL 1 N.O. CONTACT IS CLOSED NIGHT AND OPEN DAY (LIGHTS ON).
- SET LATITUDE TO 42 DEGREES, SET CH.1 TO 23 MINUTES AFTER ASTRONOMICAL SUNSET, 50 MINUTES BEFORE ASTRONOMICAL SUNRISE. SET CH.2 TO 60 MINUTES AFTER ASTRONOMICAL SUNSET (WITH A SIGNAL LENGTH OF 1 SECOND), +28 MINUTES AFTER ASTRONOMICAL SUNRISE (WITH A SIGNAL LENGTH OF 7 SECONDS.)
- BUS BAR SHALL HAVE 22 LUG TERMINALS SIZED TO ACCOMMODATE REQUIRED WIRE SIZES. 240V NEUTRAL BUS SHALL BE PAINTED WHITE, GROUND BUS SHALL BE PAINTED GREEN, AND THE 120V NEUTRAL BUS SHALL BE PAINTED GREY.
- ALL LUGS SHALL BE OF COPPER SCREWS AND CONNECTORS, SPRING HELD.
- ALL WIRING TERMINATIONS SHALL BE RATED NOT LESS THAN 75 DEGREE CENTIGRADE.
- ALL CONTROL WIRING SHALL BE 600V #12 TYPE MTW, SCADA WIRING SHALL BE #18.
- ALL POWER WIRING SHALL BE 600V TYPE RHH/RHW.
- ALL WIRING WITHIN THE CABINET SHALL BE COLOR CODED AS INDICATED:

R - RED	Y - YELLOW
B - BLACK	W - WHITE
BL- BLUE	G - GREEN
	GR - GREY
- MOSCAD I/O WIRING SHALL BE:
 - DIGITAL INPUT (DI) WIRING SHALL BE #18 MTW PURPLE.
 - ANALOG INPUT (AI) WIRING SHALL BE #18, 2/C SHIELDED.
 - AI AND DI WIRING MAY BE BUNDLED TOGETHER, BUT SHALL NOT BE BUNDLED WITH OTHER WIRING.
- ALL DIMENSIONS ARE IN INCHES (MILLIMETERS) UNLESS OTHERWISE INDICATED.
- SCHEMATIC SHOWN WITH BREAKER OPEN, CONTACTOR OPEN, CABINET DOOR CLOSED, CLOCK NOT ACTIVE (DE-ENERGIZED STATE).
- A LAMINATED COPY OF THE CIRCUIT SCHEMATIC AND SCADA I/O DIAGRAM (NO SMALLER THAN 11"x17" EACH) SHALL BE ATTACHED TO THE INSIDE OF THE CONTROLLER WITH STAINLESS STEEL SCREWS.

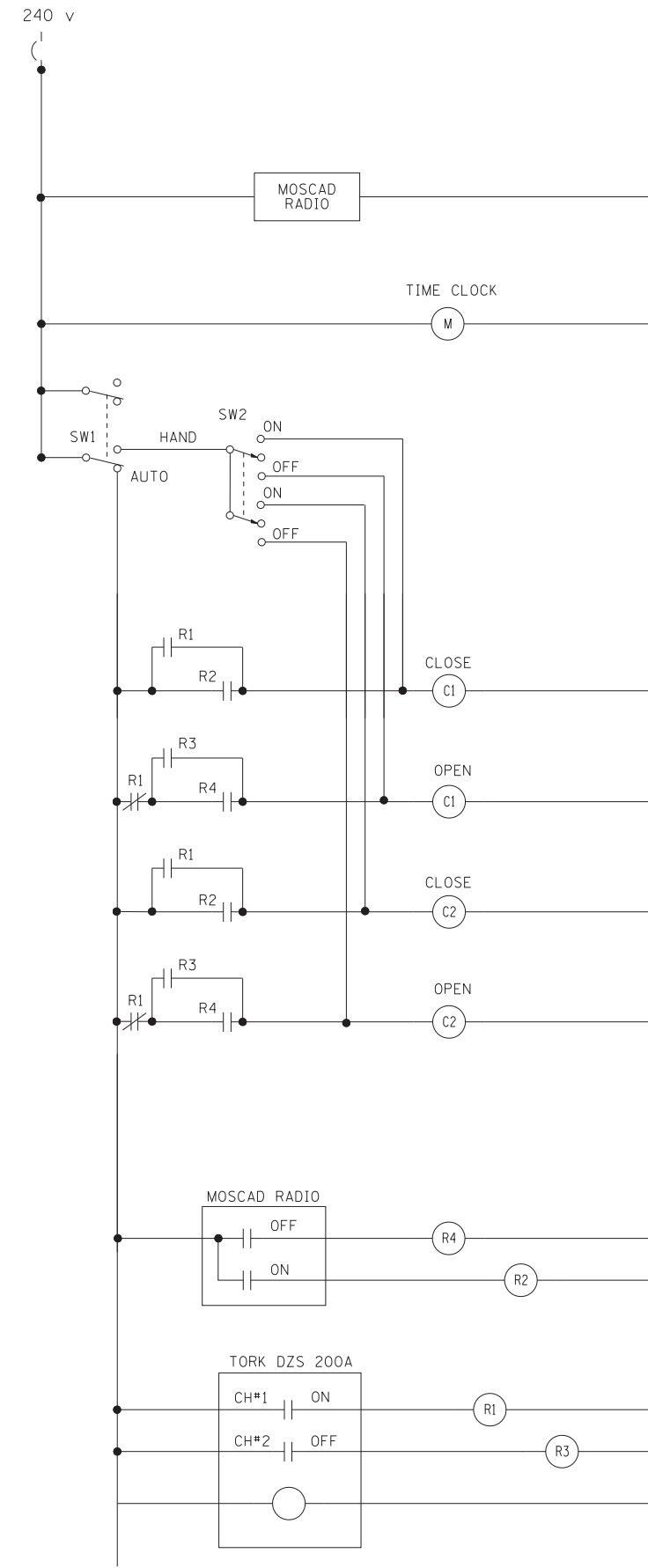

CONTROL CIRCUIT LADDER LOGIC DIAGRAM

MOSCAD I/O ASSIGNMENTS		
TERM	MOSCAD DESTINATION	DESCRIPTION OF INPUT
1	DIGITAL INPUT 1	ALARM KNOWLEDGE
2	DIGITAL INPUT 2	DOOR OPEN
3	DIGITAL INPUT 3	MAINS) BREAKER OPEN
4	DIGITAL INPUT 4	CONTACTOR 1 OPEN
5	DIGITAL INPUT 5	CONTACTOR 2 OPEN
6	DIGITAL INPUT 6	CABINET IN NON-AUTO
7	DIGITAL INPUT 7	BACK-UP CLOCK OFF CALL
8	DIGITAL INPUT 8	BACK-UP CLOCK ON CALL
17	24 V+	24+VDC
18	DI COMMON	COMMON
21	K1 C	K1 COMMON
22	K1 NO	LIGHTS ON CALL
24	K2 C	K2 COMMON
25	K2 NO	LIGHTS OFF CALL
32	ANALOG INPUT 1 (+)	CABINET NEUTRAL CURRENT
33	ANALOG INPUT 1 (-)	CABINET NEUTRAL CURRENT
34	ANALOG INPUT 2 (+)	CABINET SERVICE VOLTAGE
35	ANALOG INPUT 2 (-)	CABINET SERVICE VOLTAGE
40	P. GROUND	GROUND

ALL ANALOG INPUTS WILL BE 4-20 MA ONLY. DIGITAL OUTPUT RELAYS WILL BE ELECTRICALLY ENERGIZED AND MOMENTARILY HELD
MIXED I/O MODULE MODEL NUMBER V436

FILE NAME =	USER NAME = drivakosgn	DESIGNED -	REVISED - R. TOMSONS 08-19-04
ct:\pwwork\pwidot\DRIVAKOSGN\d0108315\be205.dgn		DRAWN -	REVISED - R. TOMSONS 05-11-09
	PLOT SCALE = 50.000' / IN.	CHECKED -	REVISED -
	PLOT DATE = 5/11/2009	DATE -	REVISED -

STATE OF ILLINOIS
DEPARTMENT OF TRANSPORTATION

LIGHTING CONTROLLER, RADIO CONTROL
DUPLIX TYPE WITH SCADA

SCALE: NONE SHEET NO. 21 OF 53 SHEETS STA. TO STA.

F.A. RTE.	SECTION	COUNTY	TOTAL SHEETS	SHEET NO.
94	49-1-R-1	LAKE	677	381
BE-205		CONTRACT NO. 60L77		
FED. ROAD DIST. NO. 1 ILLINOIS FED. AID PROJECT				

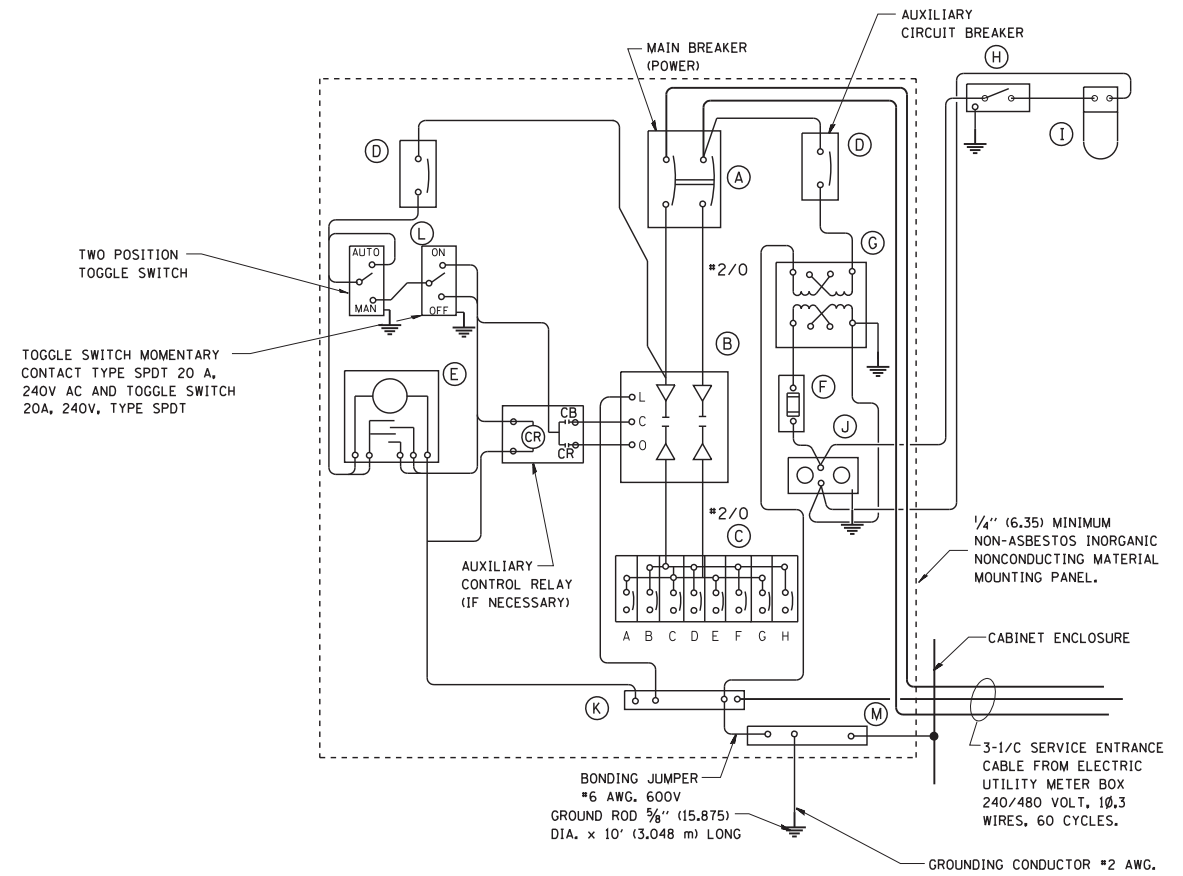

PANEL WIRING DIAGRAM

PANEL EQUIPMENT

BILL OF MATERIAL		
ITEM	QUANTITY	DESCRIPTION
A	1	MAIN CIRCUIT BREAKER, 2 POLE, 600 VOLT 100 AMP. FRAME, 100 AMP. NON-INTERCHANGEABLE TRIP INTERRUPTING RATING NEMA-22000 AMP. AT 480 VOLT.
B	1	REMOTE CONTROL SWITCH, ELECTRICALLY OPERATED, MECHANICALLY HELD, 2 POLE, SINGLE THROW, 100 AMP., 600 VOLTS CONTROL CIRCUIT 240 VOLT.
C	8	CIRCUIT BREAKERS, 1 POLE, 100AMP. FRAME, 50 AMP. NON-INTERCHANGEABLE TRIP INTERRUPTING RATING NEMA-10,000 AMP. AT 240 V.
D	2	CONTROL CIRCUIT-CIRCUIT BREAKER, 1 POLE, 240 V., 100 AMP. FRAME, 15 AMP. NON-INTERCHANGEABLE TRIP INTERRUPTING RATING NEMA-5000 AMP. AT 240 V.
E	1	ASTRONOMIC MICROPROCESSOR-BASED 2-CHANNEL CONTROLLER (TIME SWITCH).
F	1	20 A., 120 V. FUSE.
G	1	1.5 KVA, SINGLE PHASE, ENCAPSULATED TRANSFORMER 240 X 480 / 120 X 240 VOLT, 60 Hz.
H	1	SPST 20A SWITCH ON DOOR, TO TURN LIGHT ON WHEN DOOR IS OPEN.
I	1	INCANDESCENT LIGHTING FIXTURE ENCLOSED AND GASKETED WITH 60 WATT, 120 V. LAMP.
J	1	20 A., 120 V., DUPLEX RECEPTACLE, GFCI.
K	1	COPPER GROUND BUS 1/4" (6.35) X 1" (25.4) X 12" (304.8 mm) LONG MOUNTED ON PANEL WITH LUGS AND 4 SPARE LUGS
L	1	TOGGLE SWITCHES MOUNTED IN 4" (101.6) X 4" (101.6 mm) BOX.
M	1	COPPER GROUND BUS 1/4" (6.35) X 1" (25.4) X 12" (304.8 mm) LONG MOUNTED ON PANEL WITH LUGS AND SPARE LUGS

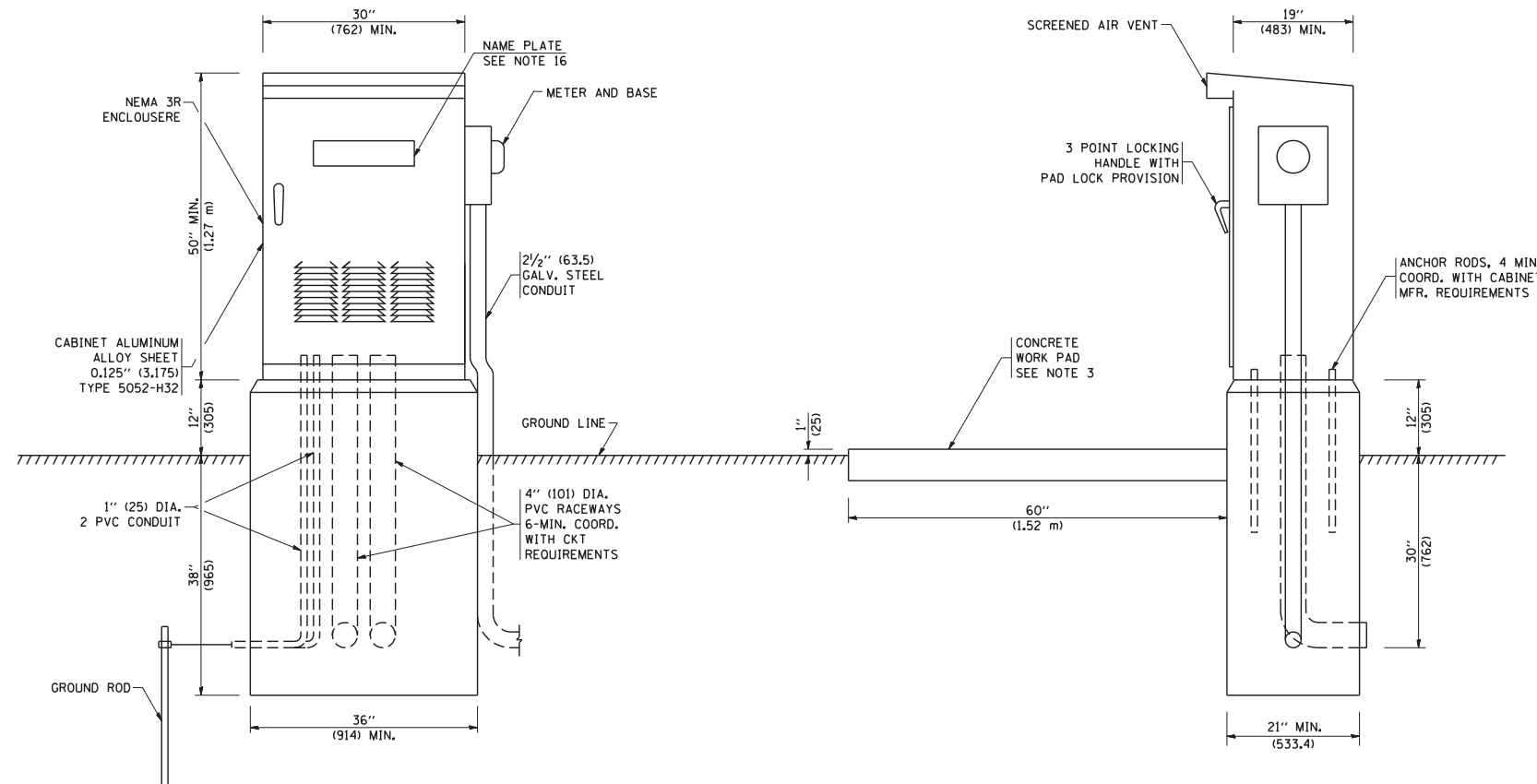

NOTES:

- ALL DIMENSIONS ARE IN INCHES (MILLIMETERS) UNLESS OTHERWISE SHOWN.
- FOUNDATION SIZE SHALL BE COORDINATED WITH CABINET SIZE AND MFR.
- IN FRONT OF CONTROL CABINET DOOR, REMOVE VEGETATION AND 2" (50.8 mm) TOP SOIL, LEVEL THE AREA AND ON TOP, PLACE LENGTH WISE PARALLEL TO CONTROL CABINET, A CONCRETE PAD 36" (914.4 mm) x 60" (18.288 m) x 4" (101 mm) MIN. SIZE. THE COST OF LABOR AND MATERIALS ARE INCLUDED IN THE COST OF THE CONTROLLER.
- DOOR SHALL BE CONSTRUCTED FROM SAME TYPE OF MATERIAL AND THICKNESS AS CABINET.
- DOOR SHALL BE EQUIPPED WITH THREE POINT LATCHING MECHANISM WITH NYLON ROLLERS AT TOP THE BOTTOM.
- DOOR HINGE SHALL BE A HEAVY GAUGE CONTINUOUS HINGE WITH A 1/4" (6.35 mm) DIA. STAINLESS STEEL HINGE PIN.
- ALL EXTERNAL HARDWARE SHALL BE STAINLESS STEEL.
- CONTROL WIRING TO BE #12 AWG, 600V, TYPE "SIS" GRAY SWITCH BOARD WIRE, STRANDED COPPER.
- METER BOX SHALL BE MOUNTED ON THE SIDE OF CONTROL CABINET, NEAR TO THE SERVICE POLE.
- CABINETS SHALL BE PRIMED AND PAINTED AS SPECIFIED.
- THE HEADS OF CONNECTORS SCREWS SHALL BE PAINTED WHITE FOR NEUTRAL BAR CONNECTION AND GREEN FOR GROUND BAR CONNECTORS.
- ALL WIRING WITHIN THE CABINET SHALL BE COLOR CODED AS INDICATED.
R = RED BL = BLUE W = WHITE
B = BLACK Y = YELLOW G = GREEN
- PROVIDE SEALING GROMMETS FOR ALL OPEN WIRING EXTENDED FROM DEVICES IN BOXES OR CABINETS WITHIN THE CONTROL CABINET.
- ALL WIRING SHALL BE NEATLY DRESSED AND SUPPORTED.
- THE CONTROLLER SHALL BE CONSTRUCTED TO U.L. STD. 508 AND BEAR THE U.L. LABEL "ENCLOSED INDUSTRIAL CONTROL PANEL".
- 12" (304.8) X 16" (406.4 mm) STAINLESS STEEL EXTERIOR NAMEPLATE SHALL BE ENGRAVED TO "STATE OF ILLINOIS LIGHTING CONTROLS" UNLESS OTHERWISE SPECIFIED.

FILE NAME =	USER NAME = geglantobt	DESIGNED -	REVISED - 08-20-04
W:\diststd\22x34\be215.dgn		DRAWN -	REVISED -
		CHECKED -	REVISED -
		DATE -	REVISED -

**STATE OF ILLINOIS
DEPARTMENT OF TRANSPORTATION**

LIGHTING CONTROLLER SINGLE DOOR	
SCALE: NONE	SHEET NO. 22 OF 53 SHEETS
STA.	TO STA.

F.A. RTE.	SECTION	COUNTY	TOTAL SHEETS	SHEET NO.
94	4-1-R-1	LAKE	677	382
BE-215		CONTRACT NO. 60L77		
FED. ROAD DIST. NO. 1 ILLINOIS FED. AID PROJECT				

LIGHT POLE FOUNDATION DEPTH TABLE
40 FT. (12.192 m) TO 47.5 FT. (14.478 m) MOUNTING HEIGHT

SOIL CONDITIONS	DESIGN DEPTH "D" OF FOUNDATION	
	SINGLE ARM POLE	TWIN ARM POLE
SOFT CLAY O _u = 0.375 TON/SO. FT.	13'-0" (3.96 m)	15'-0" (4.57 m)
MEDIUM CLAY O _u = 0.75 TON/SO.FT	9'-6" (2.93 m)	10'-9" (3.23 m)
STIFF CLAY O _u = 1.50 TON/SO. FT.	7'-0" (2.13 m)	8'-0" (2.44 m)
LOOSE SAND φ = 34°	9'-0" (2.74 m)	10'-0" (3.05 m)
MEDIUM SAND φ = 37.5°	8'-3" (2.52 m)	9'-0" (2.74 m)
DENSE SAND φ = 40°	7'-9" (2.36 m)	9'-0" (2.74 m)

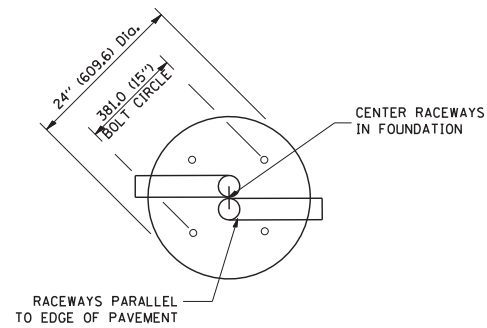

TOP VIEW

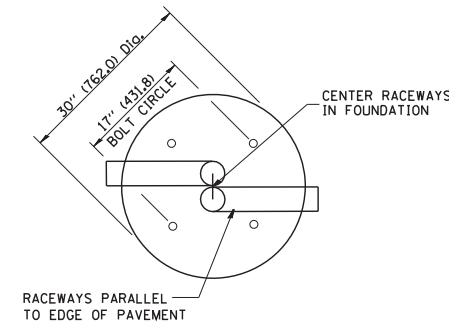

TOP VIEW

NOTES

- ALL DIMENSIONS ARE IN INCHES (MILLIMETERS) UNLESS OTHERWISE SHOWN.
- THE ANCHOR RODS AND RACEWAYS SHALL BE PROPERLY SECURED IN PLACE BEFORE THE CONCRETE IS PLACED.
- THE FOUNDATION SHALL NOT PROTRUDE MORE THAN 100MM (4 IN.) ABOVE THE FINISHED GRADE WITHIN A 60 IN. (1.5 m) CHORD ACROSS THE FOUNDATION, WITH ANCHOR RODS INCLUDED, IN ACCORDANCE WITH AASHTO GUIDELINES. IF THE FOUNDATION HEIGHT, INCLUDING ANCHOR RODS, EXTENDS BEYOND THESE SPECIFIED LIMITS, THE FOUNDATION SHALL BE REPLACED AT THE CONTRACTOR'S EXPENSE. SEE FOUNDATION EXTENSION DETAIL.
- THE HOLE FOR THE FOUNDATION SHALL BE MADE BY DRILLING WITH AN AUGER, OF THE SAME DIAMETER AS THE FOUNDATION. IF SOIL CONDITIONS REQUIRE THE USE OF A LINER TO FORM THE HOLE, THE LINER SHALL BE WITHDRAWN AS THE CONCRETE IS DEPOSITED.
- THE TOP OF THE FOUNDATION SHALL BE CONSTRUCTED LEVEL. A LINER OR FORM SHALL BE USED TO PRODUCE A UNIFORM SMOOTH SIDE TO THE TOP OF THE FOUNDATION. FOUNDATION TOP SHALL BE CHAMFERED 3/4-IN. (20 mm).
- THE CONCRETE SHALL BE CLASS SI. CONCRETE SHALL CURE ACCORDING TO ARTICLE 1020.13 BEFORE LIGHT POLES ARE INSTALLED.
- THE ANCHOR ROD SHALL BE A HOOK ROD TYPE. COLD BENDING OF THE ANCHOR ROD WILL NOT BE ALLOWED. THE RADIUS OF THE HOOK BEND SHALL NOT BE LESS THAN 4 TIMES THE NOMINAL DIAMETER OF THE ANCHOR ROD. A TACK WELDED ANCHOR ROD MAY BE SUBSTITUTED WITH THE APPROVAL OF THE ENGINEER.
- THE ANCHOR RODS SHALL BE ACCORDING TO ASTM F1554 GRADE 725 (GRADE 105). NUTS SHALL BE HEXAGON NUTS ACCORDING TO ASTM A 194 2H OR ASTM A 563 DH, AND WASHERS SHALL BE ACCORDING TO ASTM F 436.
- ANCHOR RODS, NUTS AND WASHERS SHALL BE COMPLETELY GALVANIZED BY EITHER THE HOT-DIPPED PROCESS CONFORMING WITH AASHTO M 232, THE MECHANICAL PLATING METHOD CONFORMING TO AASHTO M 298, CLASS 50 WITH A MAXIMUM COATING THICKNESS OF 150 UMG MILS) OR THE ELECTROLYTIC PROCESS ACCORDING TO ASTM F 1136.
- THE ANCHOR RODS SHALL BE THREADED A MINIMUM OF 6 INCHES (150 mm) WITH A MINIMUM OF 3 INCHES (75 mm) OF THREADED ANCHOR ROD EMBEDDED IN THE FOUNDATION.
- ANCHOR RODS SHALL PROJECT 2 3/4" (69.9 mm) ABOVE THE TOP OF THE FOUNDATION. IF BREAKAWAY COUPLINGS ARE SPECIFIED, THE CONTRACTOR SHALL CAREFULLY COORDINATE THE ANCHOR ROD PROJECTION WITH THE INSTALLATION REQUIREMENTS OF THE BREAKAWAY COUPLINGS.
- THE CONTRACTOR SHALL USE A #3 SPIRAL AT 6" (152.4 mm) PITCH OR MAY SUBSTITUTE #3 TIES AT 12" (304.8 mm) O.C. WITH THE APPROVAL OF THE ENGINEER.
- THE CABLE TRENCHES AND FOUNDATION SHALL BE BACK FILLED AND COMPACTED AS SPECIFIED BEFORE THE LIGHT POLE IS ERECTED.
- THE RACEWAYS SHALL PROJECT 1" (25.4 mm) ABOVE THE TOP OF THE FOUNDATION.

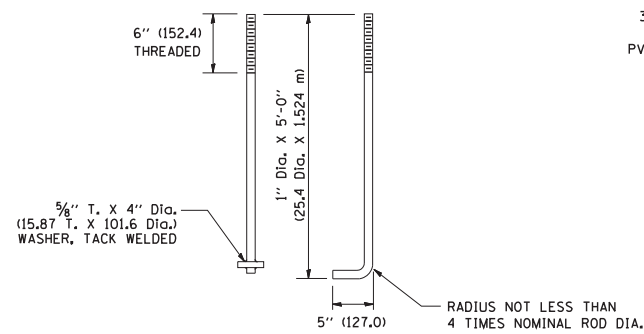

ANCHOR ROD DETAIL

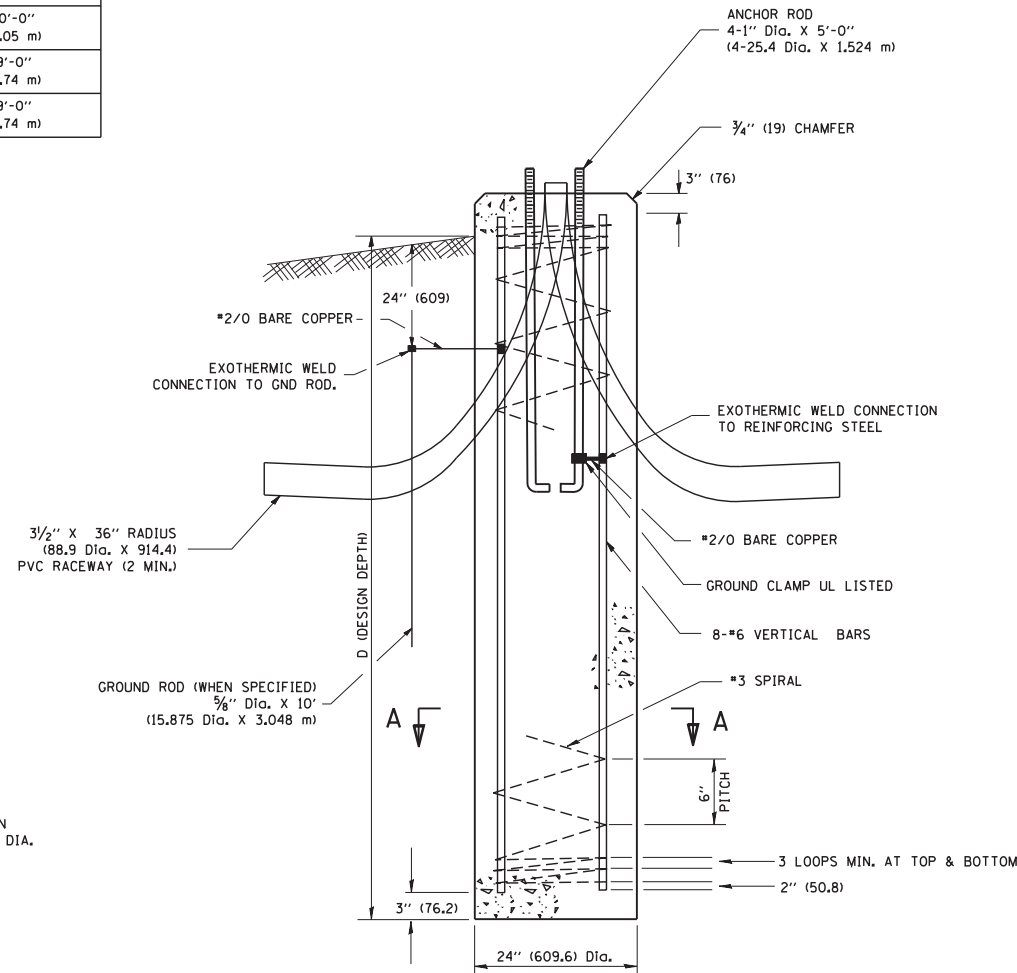

FOUNDATION DETAIL

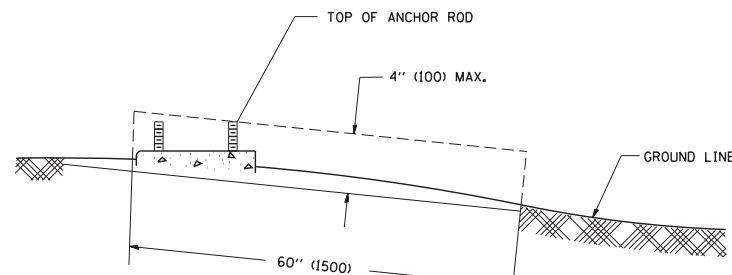

FOUNDATION EXTENSION DETAIL

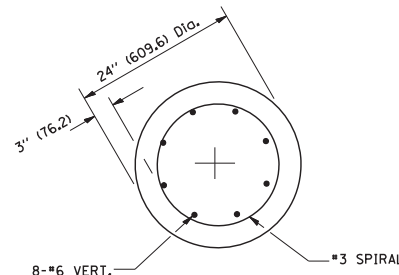

SECTION A-A

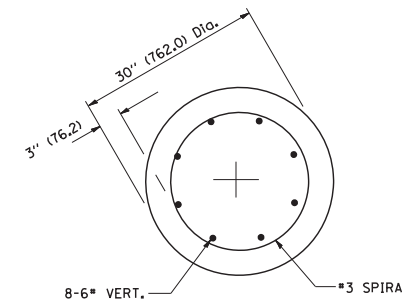

SECTION A-A

FILE NAME = W:\diststd\22x34\be301.dgn	USER NAME = gaglionobt	DESIGNED -	REVISED - 04-22-02
		DRAWN -	REVISED -
		CHECKED -	REVISED -
		DATE -	REVISED -

STATE OF ILLINOIS
DEPARTMENT OF TRANSPORTATION

LIGHT POLE FOUNDATION
40' (12.192 m) TO 47' 1/2' (14.478 m) M.H. 15" (381 mm) BOLT CIRCLE
SCALE: NONE SHEET NO. 23 OF 53 SHEETS STA. TO STA.

F.A. RTE. 94	SECTION 49-1-R-1	COUNTY LAKE	TOTAL SHEETS 677	SHEET NO. 383
BE-301		CONTRACT NO. 60L77		
FED. ROAD DIST. NO. 1 ILLINOIS FED. AID PROJECT				

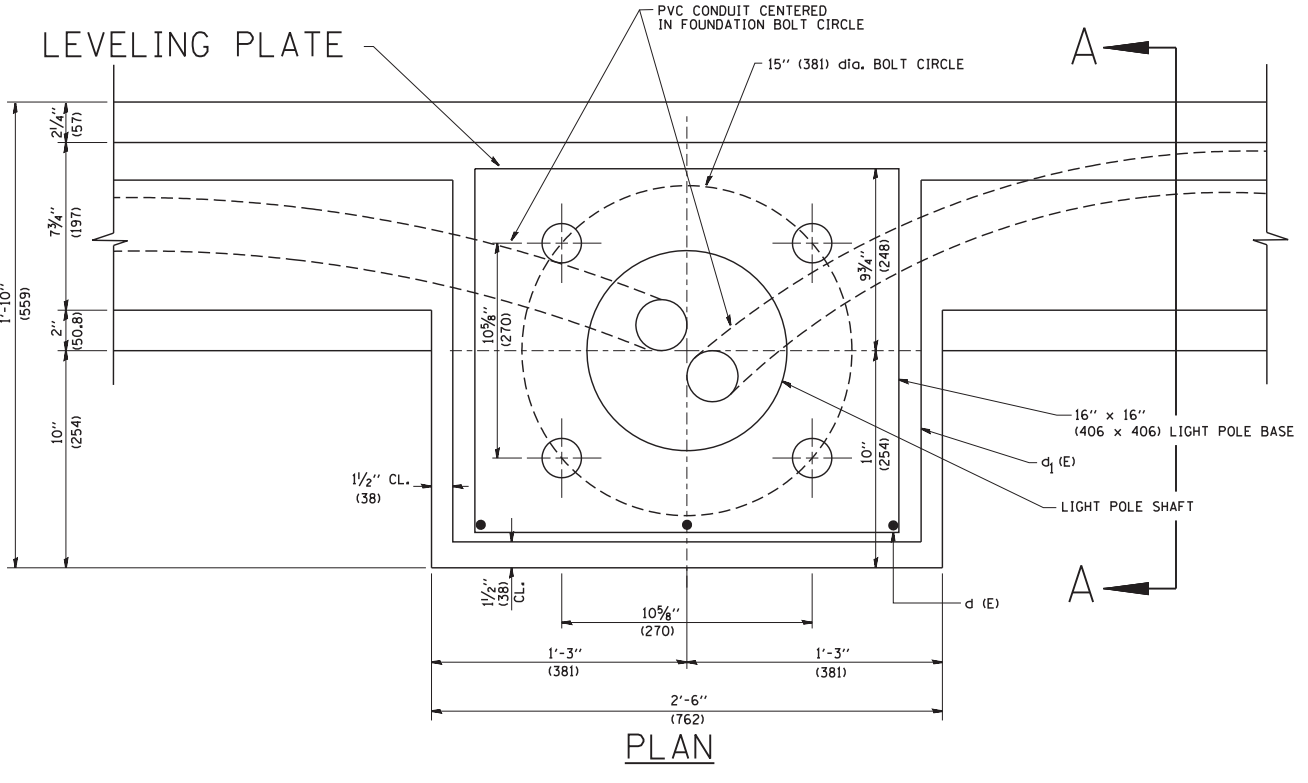
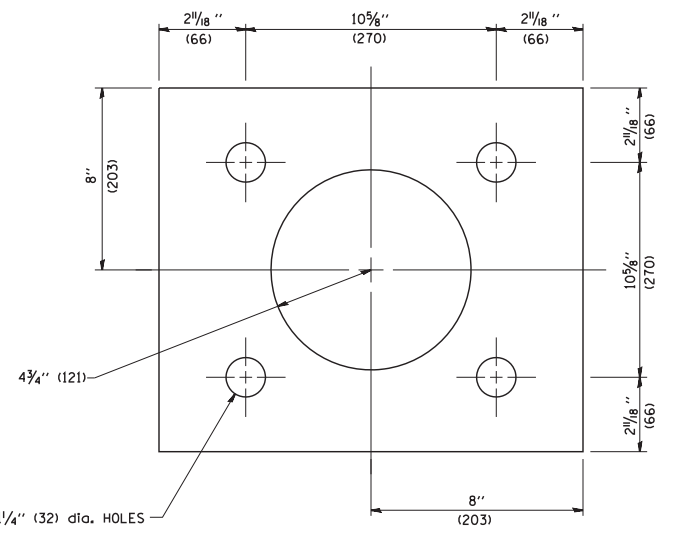
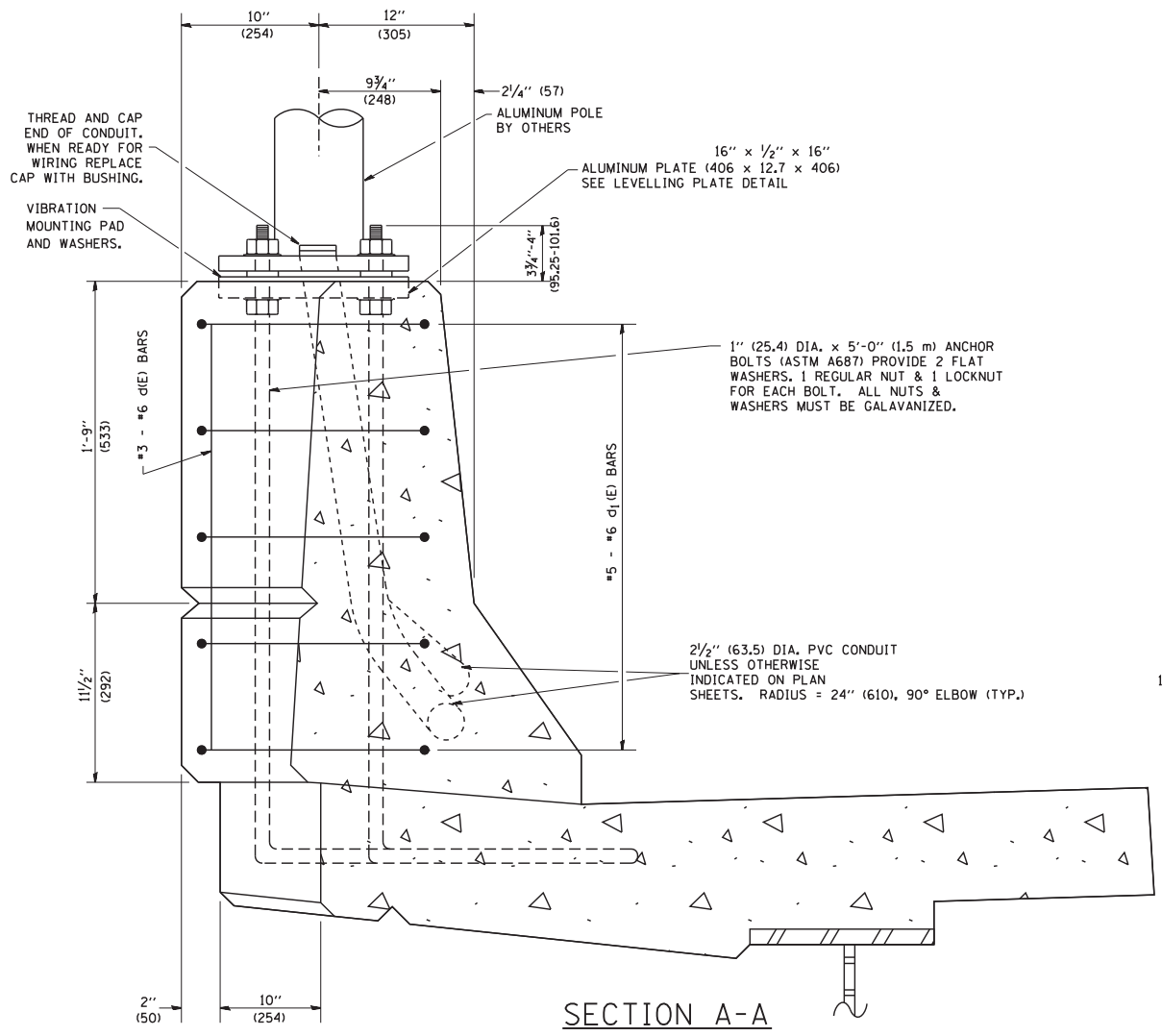
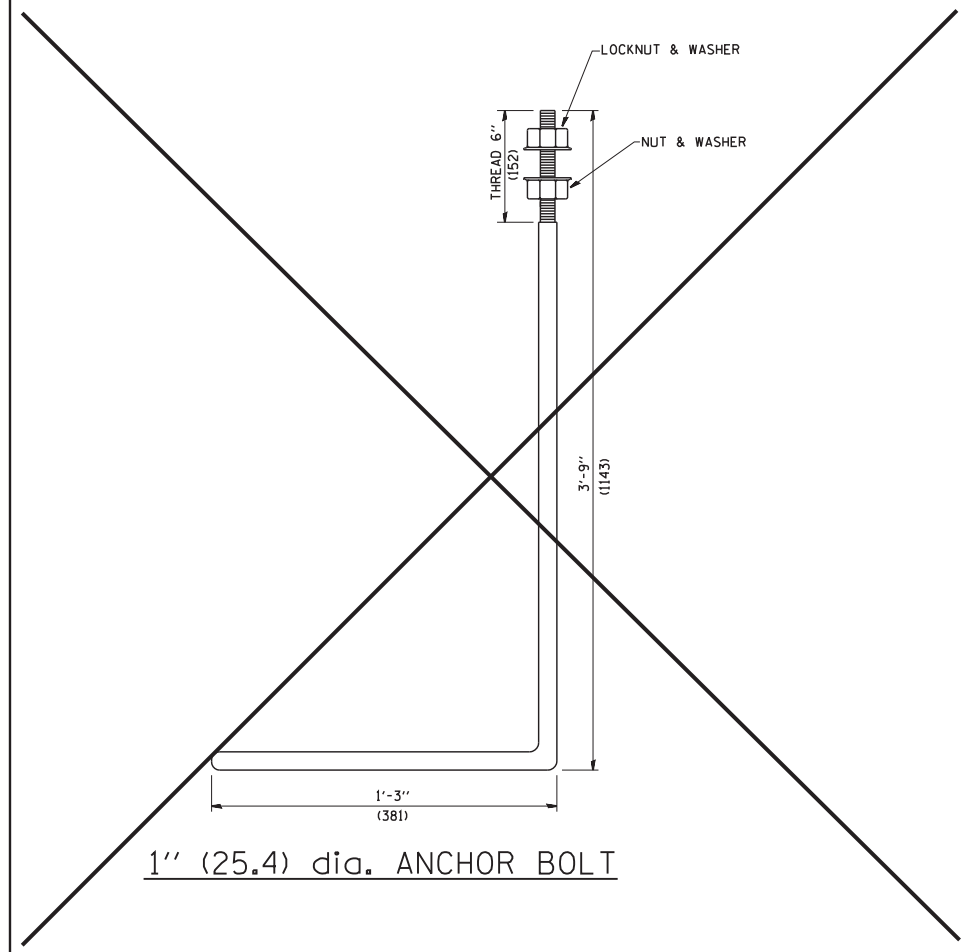
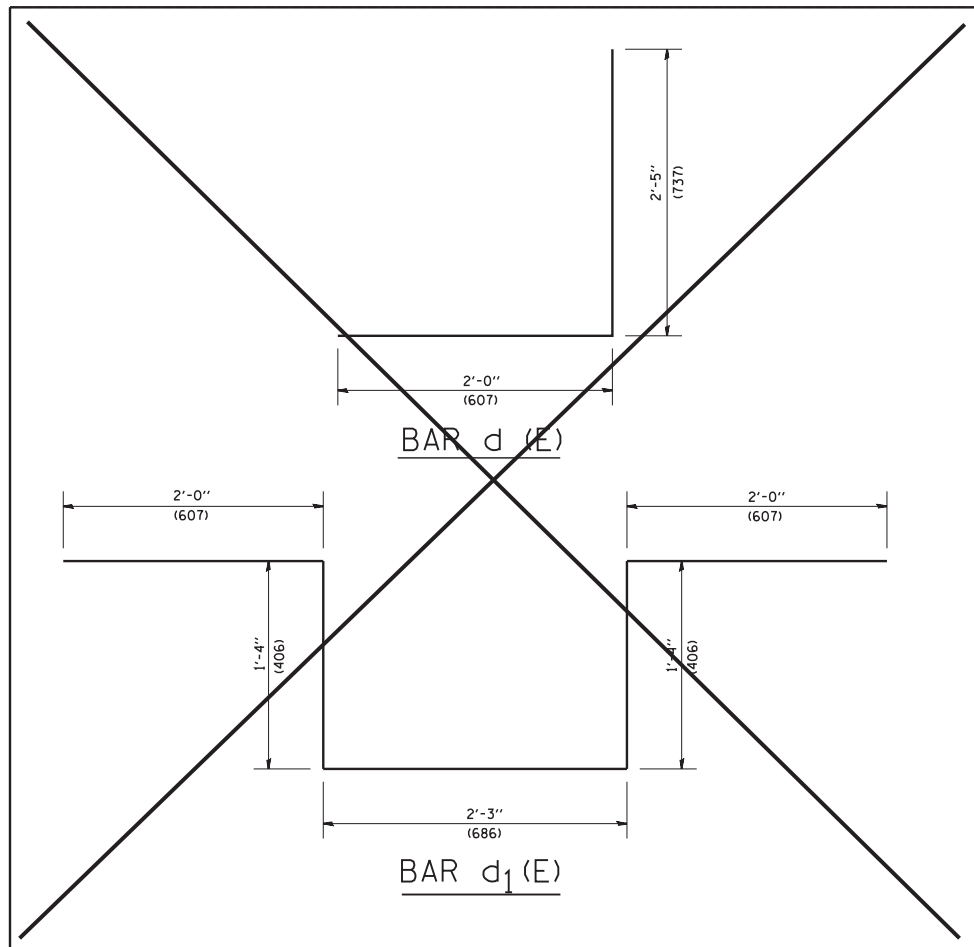

- NOTES**
1. ALL DIMENSIONS ARE IN INCHES (MILLIMETERS) UNLESS OTHERWISE SHOWN.
 2. LEVEL LIGHT POLE PLATES, USING THE FLANGE NUTS, PRIOR TO POURING THE PARAPET WALL. THE TOP OF THE PLATE SHALL BE AT THE SAME ELEVATION AS THE FINISHED CONCRETE PARAPET.
 3. THE COST OF ANCHOR BOLTS, CONDUIT, LEVELLING PLATE AND FOUNDATION IS INCLUDED IN THE COST OF THE BRIDGE STRUCTURE.
 4. SEE BRIDGE PLANS FOR ANCHOR BOLT, REINFORCEMENT, AND PARAPET DIMENSION DETAILS.

FILE NAME = W:\diststd\22x34\be330.dgn	USER NAME = gaglionobt	DESIGNED -	REVISED - 04-22-02
		DRAWN -	REVISED -
		CHECKED -	REVISED -
		DATE -	REVISED -

**STATE OF ILLINOIS
DEPARTMENT OF TRANSPORTATION**

**LIGHT POLE MOUNTED ON CONCRETE PARAPET WALL
15" (381 mm) BOLT CIRCLE**

SCALE: NONE SHEET NO. 24 OF 53 SHEETS STA. TO STA.

F.A. RTE. 94	SECTION 49-1-R-1	COUNTY LAKE	TOTAL SHEETS 677	SHEET NO. 384
BE-330		CONTRACT NO. 60L77		
FED. ROAD DIST. NO. 1 ILLINOIS FED. AID PROJECT				

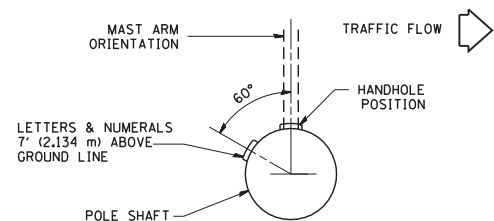

POSITION OF HANDHOLE AND POLE NUMBER FOR SINGLE MAST ARM POLES MOUNTED ON BRIDGE PARAPET OR BARRIER WALL

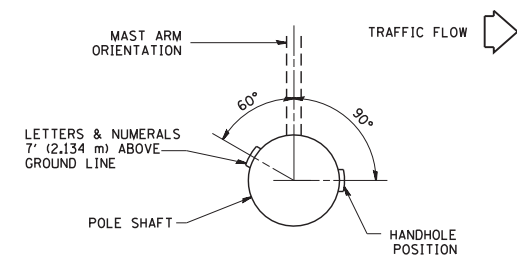

POSITION OF HANDHOLE AND POLE NUMBER FOR SINGLE MAST ARM POLES

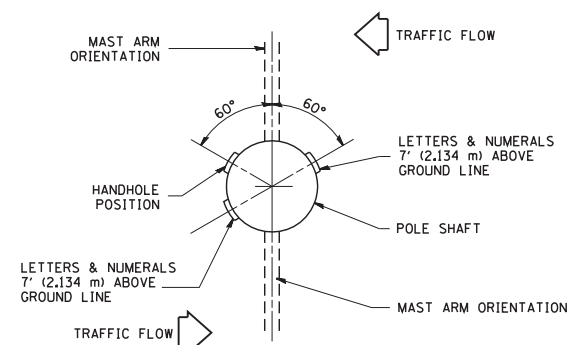

POSITION OF HANDHOLE AND POLE NUMBER FOR TWIN MAST ARM POLES

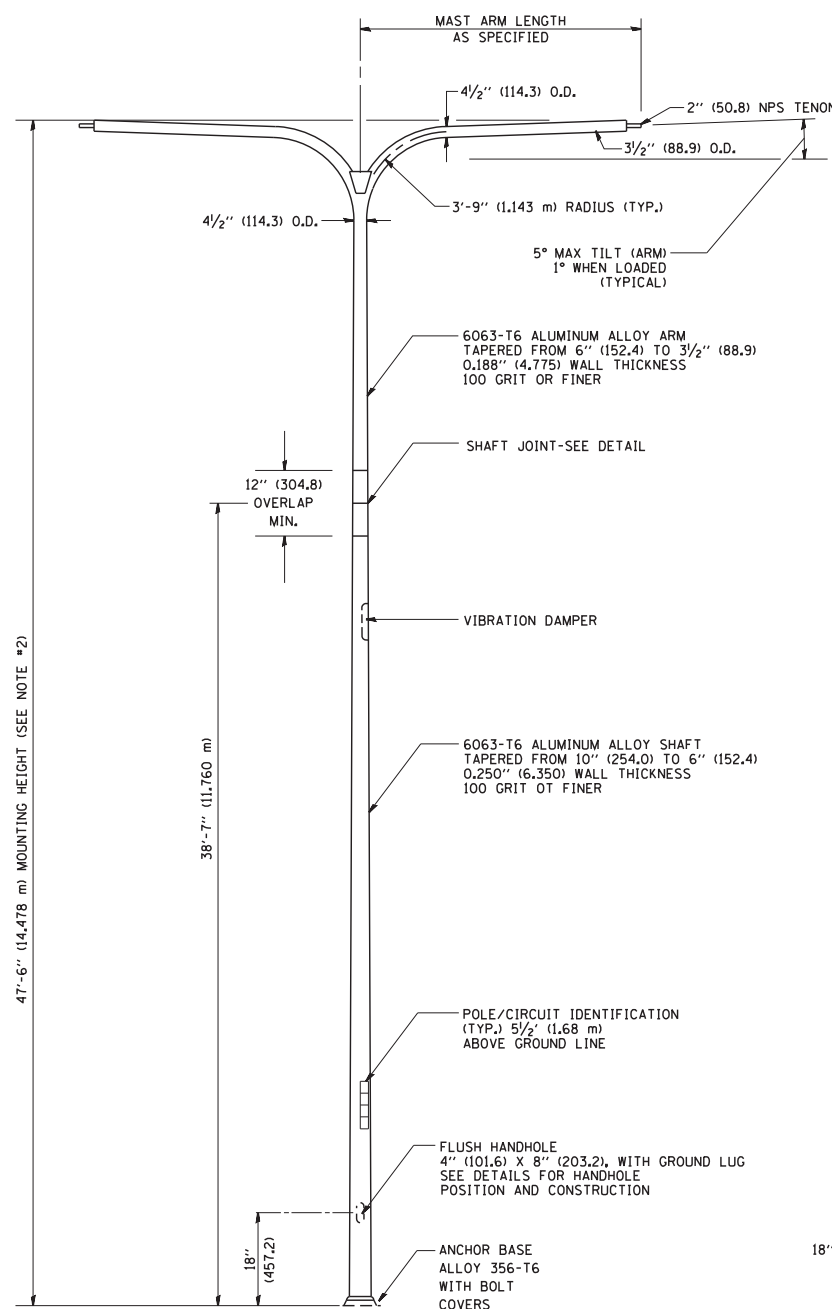

TWIN ARM POLE

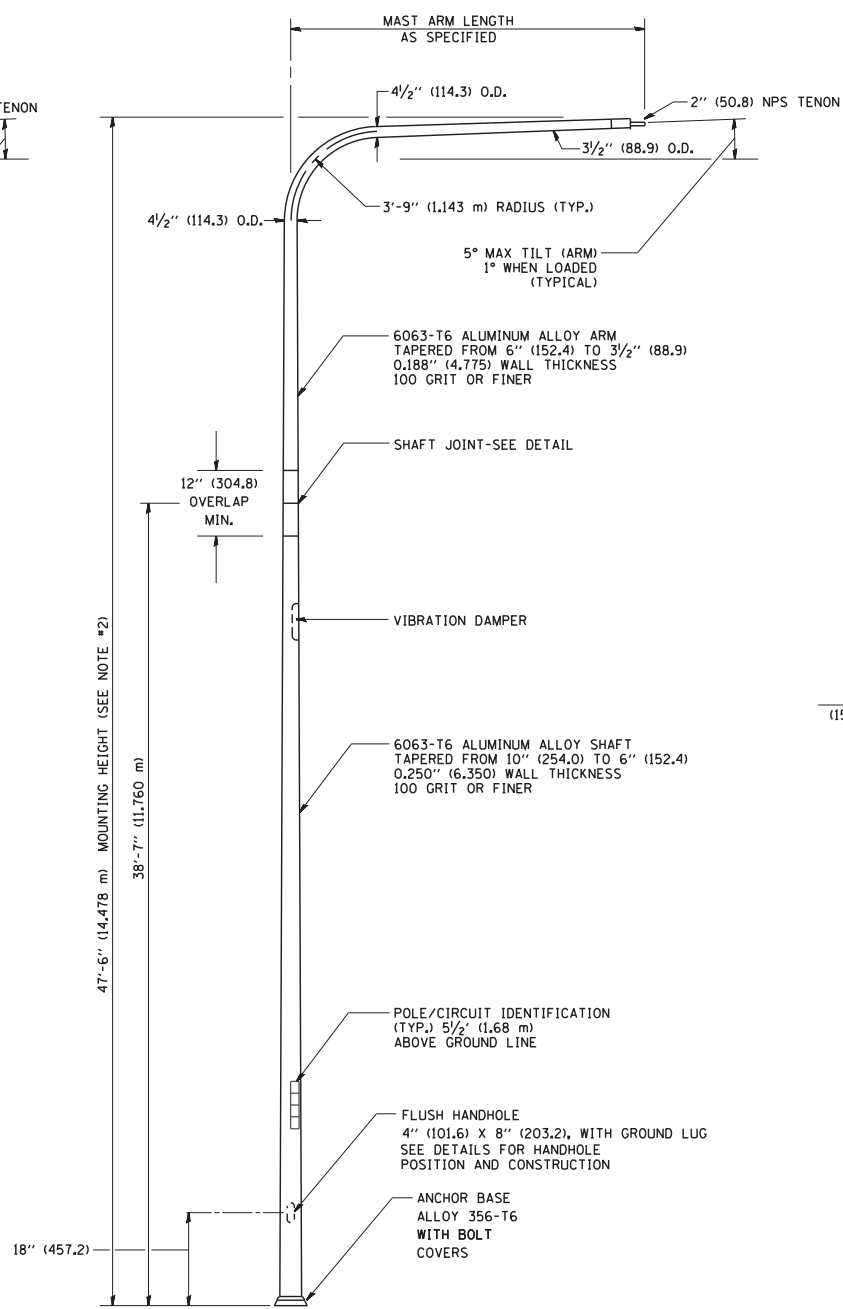

SINGLE ARM POLE

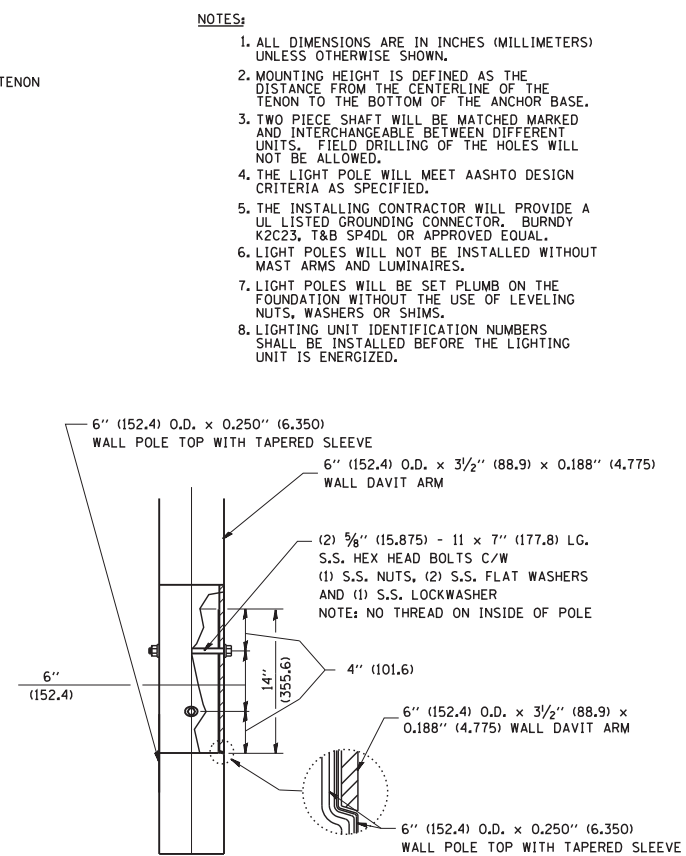

DAVIT ARM CONNECTION [14" (355.6) OVERLAP SHOWN]

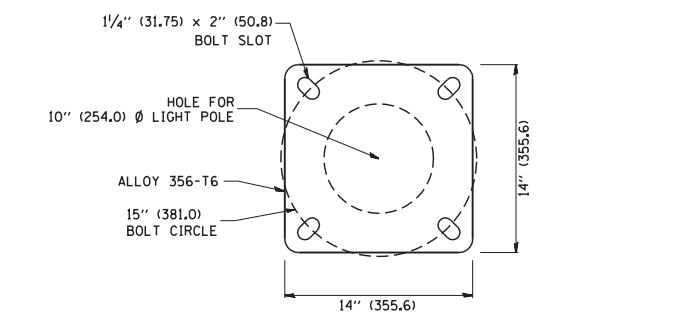

LIGHT POLE BASE PLATE DETAIL (FOR POLE MOUNTED ON 15 INCH (381.0) BOLT CIRCLE FOUNDATION)

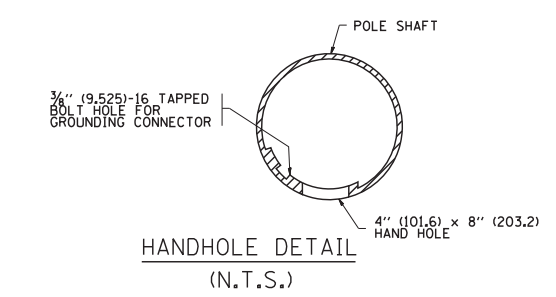

HANDHOLE DETAIL (N.T.S.)

- NOTES:
1. ALL DIMENSIONS ARE IN INCHES (MILLIMETERS) UNLESS OTHERWISE SHOWN.
 2. MOUNTING HEIGHT IS DEFINED AS THE DISTANCE FROM THE CENTERLINE OF THE TENON TO THE BOTTOM OF THE ANCHOR BASE.
 3. TWO PIECE SHAFT WILL BE MATCHED MARKED AND INTERCHANGEABLE BETWEEN DIFFERENT UNITS. FIELD DRILLING OF THE HOLES WILL NOT BE ALLOWED.
 4. THE LIGHT POLE WILL MEET AASHTO DESIGN CRITERIA AS SPECIFIED.
 5. THE INSTALLING CONTRACTOR WILL PROVIDE A UL LISTED GROUNDING CONNECTOR, BURNDY K2C23, T&B SP40L OR APPROVED EQUAL.
 6. LIGHT POLES WILL NOT BE INSTALLED WITHOUT MAST ARMS AND LUMINAIRES.
 7. LIGHT POLES WILL BE SET PLUMB ON THE FOUNDATION WITHOUT THE USE OF LEVELING NUTS, WASHERS OR SHIMS.
 8. LIGHTING UNIT IDENTIFICATION NUMBERS SHALL BE INSTALLED BEFORE THE LIGHTING UNIT IS ENERGIZED.

FILE NAME = W:\diststd\22x34\be410.dgn	USER NAME = gaglionobt	DESIGNED -	REVISED - D. DREW 04-02-92	STATE OF ILLINOIS DEPARTMENT OF TRANSPORTATION	DAVIT LIGHT POLE 47'-6" (14.478 m) MOUNTING HEIGHT			F.A. RTE. = 94	SECTION = 49-1-R-1	COUNTY = LAKE	TOTAL SHEETS = 677	SHEET NO. = 385
	PLOT SCALE = 50.0000' / IN.	DRAWN - LEY	REVISED - D. DREW 05-07-92		SCALE: NONE	SHEET NO. 25 OF 53 SHEETS	STA. TO STA.	BE-410		CONTRACT NO. 60L77		
	PLOT DATE = 1/4/2008	CHECKED -	REVISED - R. TOMSONS 09-06-00					FED. ROAD DIST. NO. 1 ILLINOIS FED. AID PROJECT				
		DATE -	REVISED - R. TOMSONS 09-02-03									

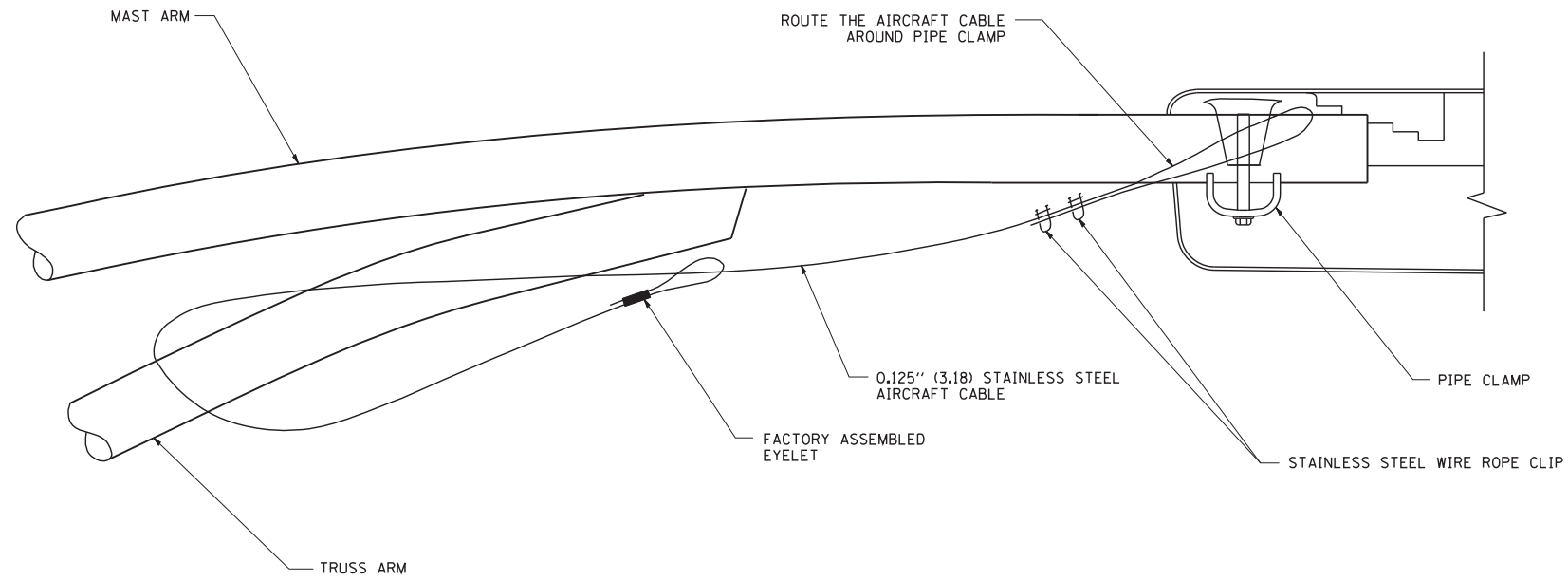

SIDE VIEW (TRUSS ARM)
N.T.S.

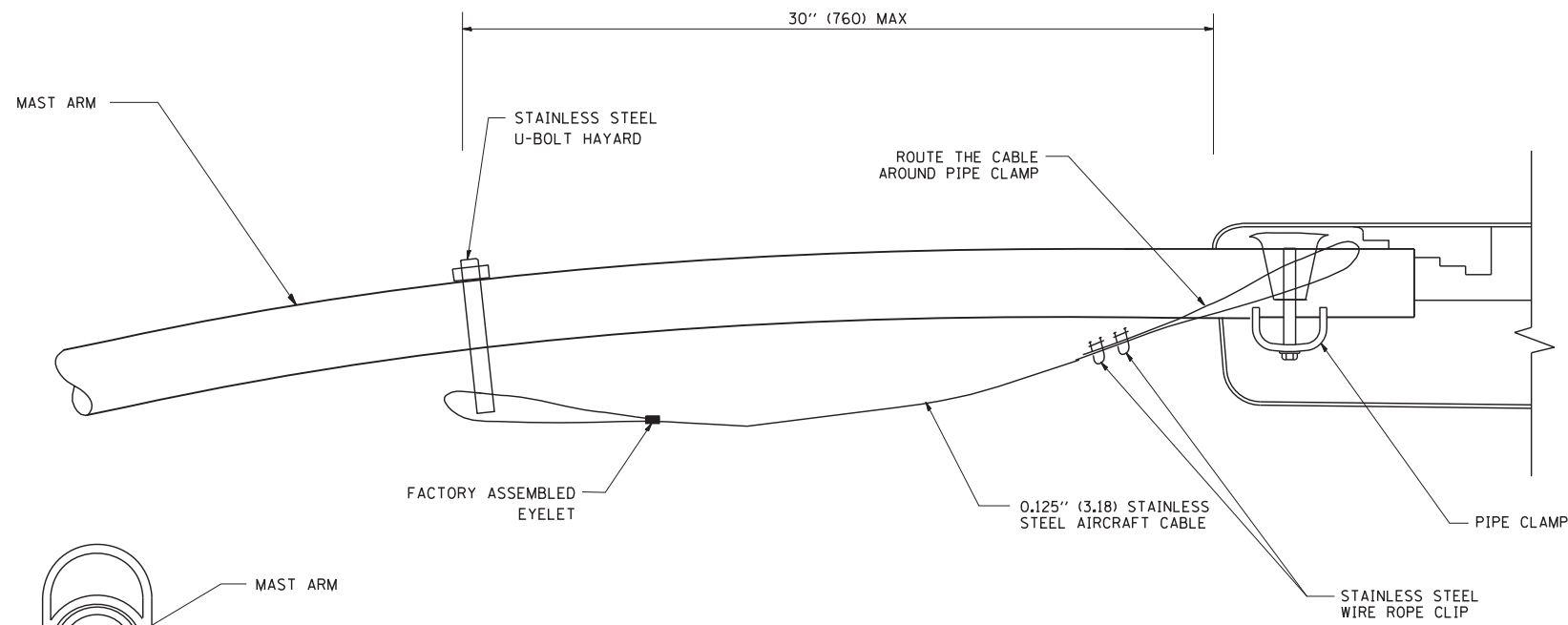

SIDE VIEW (SINGLE MEMBER OR DAVIT ARM)
N.T.S.

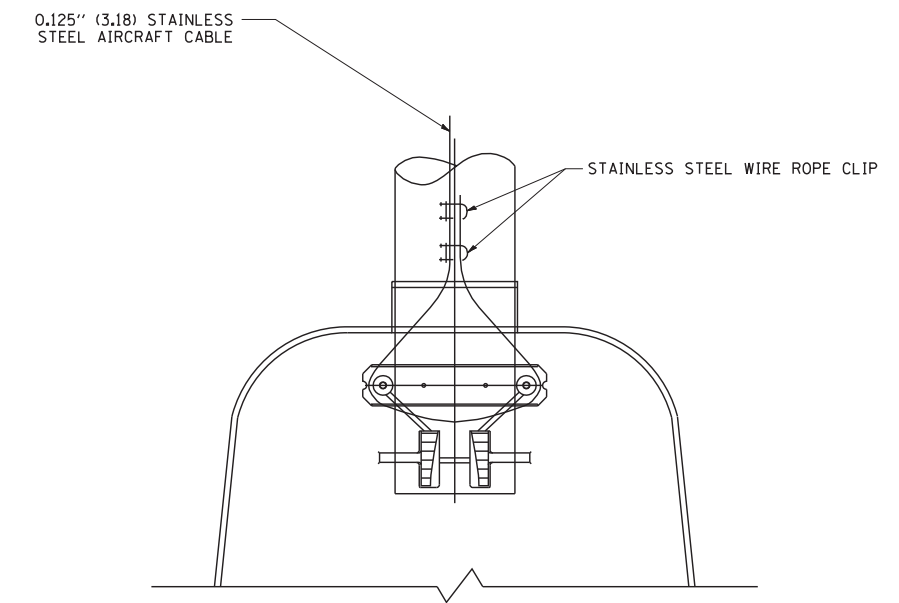
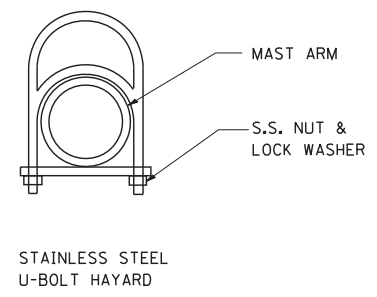

BOTTOM VIEW
N.T.S.

NOTES:

1. ALL DIMENSIONS ARE IN MILLIMETERS (INCHES) UNLESS OTHERWISE SHOWN.
2. CONTRACTOR SHALL ADJUST THE WIRE CLIP TO ELIMINATE ANY SLACK FROM THE WIRE ROPE.
3. THE 0.125" (3.18) STAINLESS STEEL AIRCRAFT CABLE SHALL REMAIN VISIBLE FROM THE GROUND LEVEL.
4. THE BREAKING STRENGTH OF THE CABLE SHALL BE 1700 LBS. MIN.

FILE NAME = W:\diststd\22x34\be701.dgn	USER NAME = gaglionobt	DESIGNED -	REVISED - 08-08-03	STATE OF ILLINOIS DEPARTMENT OF TRANSPORTATION	LUMINAIRE SAFETY CABLE ASSEMBLY			F.A. RTE. =	SECTION	COUNTY	TOTAL SHEETS	SHEET NO.
	PLOT SCALE = 50.000' / IN.	CHECKED -	REVISED -					94	4-1-R-1	LAKE	677	386
PLOT DATE = 1/4/2008	DATE -	REVISED -	REVISED -	SCALE: NONE	SHEET NO. 26 OF 53 SHEETS	STA.	TO STA.	BE-701		CONTRACT NO. 60L77		
								FED. ROAD DIST. NO. 1 ILLINOIS FED. AID PROJECT				

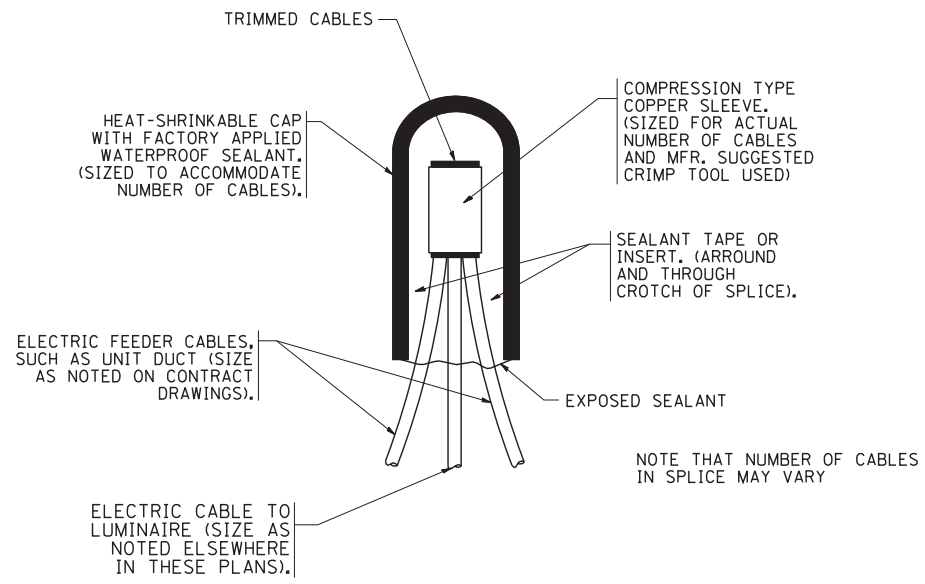

TYPICAL SPLICE DETAIL

N.T.S.

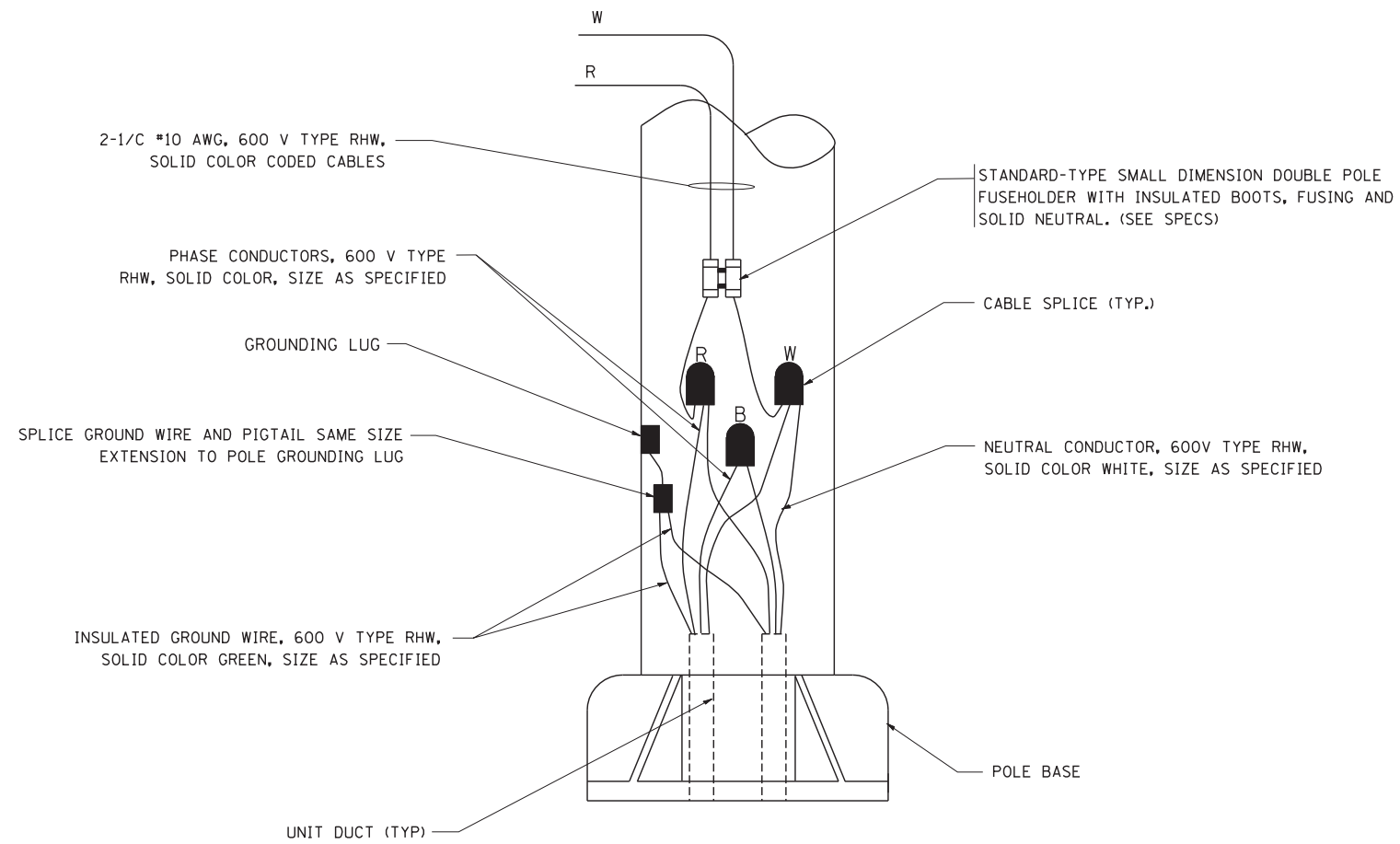

POLE WIRING DETAIL

N.T.S.

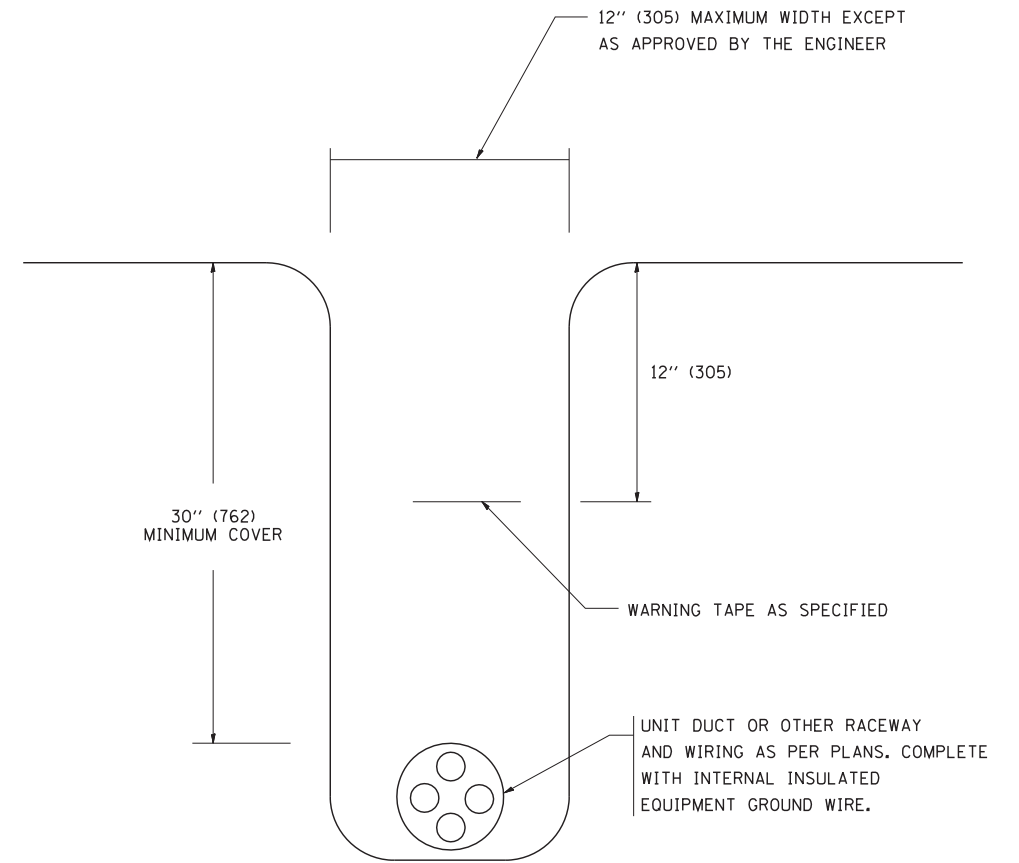

TYPICAL WIRING IN TRENCH DETAIL

N.T.S.

FILE NAME =	USER NAME = gegltonbt
W:\diststd\22x34\be702.dgn	
PLOT SCALE = 50.000' / IN.	
PLOT DATE = 1/4/2008	

DESIGNED -	REVISED - 08-08-03
DRAWN -	REVISED -
CHECKED -	REVISED -
DATE -	REVISED -

**STATE OF ILLINOIS
DEPARTMENT OF TRANSPORTATION**

MISC. ELECTRICAL DETAILS SHEET A			
SCALE: NONE	SHEET NO. 27 OF 53 SHEETS	STA.	TO STA.

F.A. RTE.	SECTION	COUNTY	TOTAL SHEETS	SHEET NO.
94	49-1-R-1	LAKE	677	387
BE-702			CONTRACT NO. 60L77	
FED. ROAD DIST. NO. 1 ILLINOIS FED. AID PROJECT				

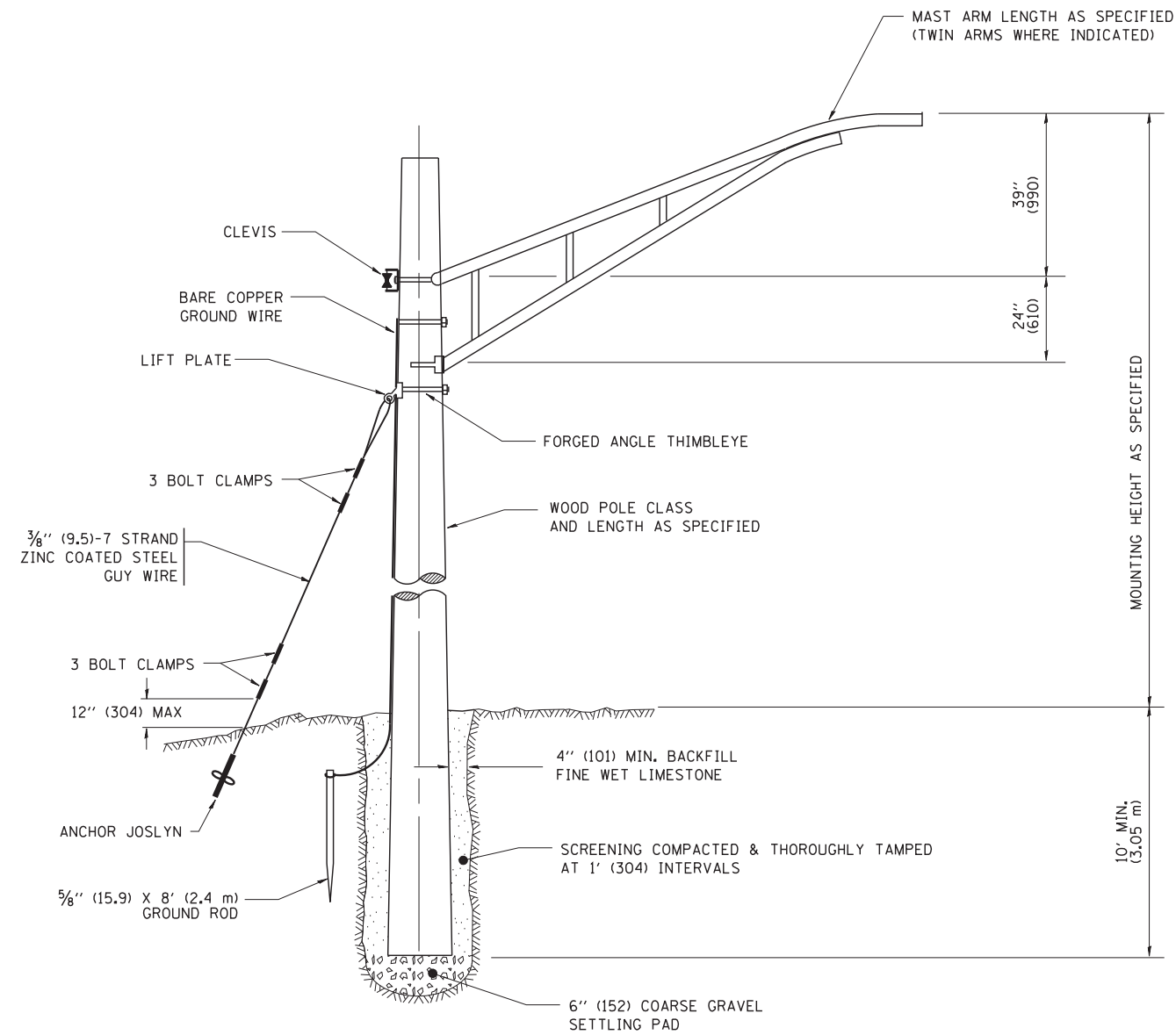

TEMPORARY LIGHT POLE DETAIL

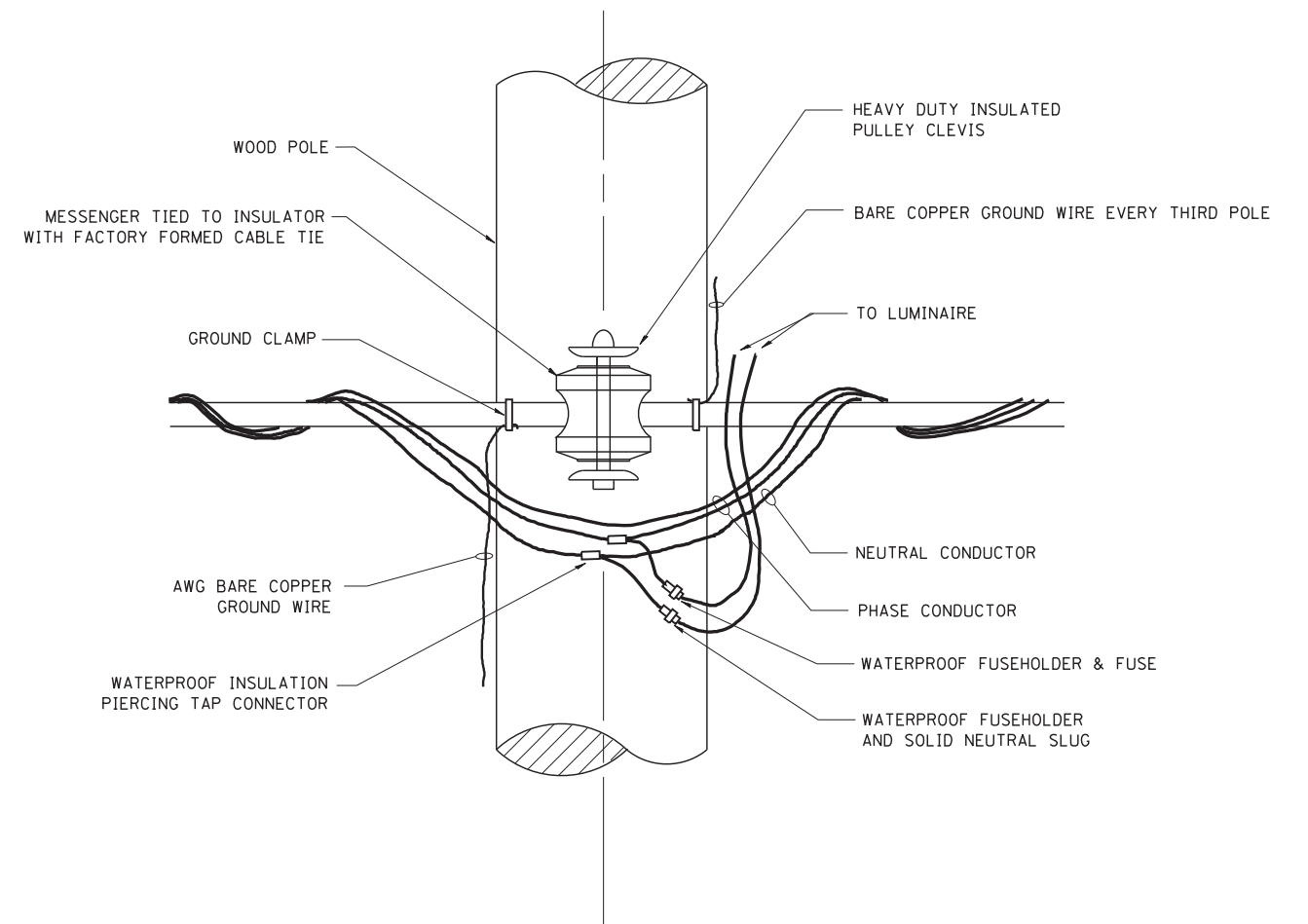

TEMPORARY LIGHT POLE ATTACHMENT DETAIL

NOTES:

1. ALL DIMENSIONS IN INCHES (MILLIMETERS) UNLESS OTHERWISE INDICATED

FILE NAME = W:\diststd\22x34\be800.dgn	USER NAME = gaglionobt	DESIGNED -	REVISED - 08-08-03
		DRAWN -	REVISED -
	PLOT SCALE = 50.000' / IN.	CHECKED -	REVISED -
	PLOT DATE = 1/4/2008	DATE -	REVISED -

**STATE OF ILLINOIS
DEPARTMENT OF TRANSPORTATION**

TEMPORARY LIGHT POLE DETAILS

SCALE: NONE SHEET NO. 28 OF 53 SHEETS STA. TO STA.

F.A. RTE. 94	SECTION 49-1-R-1	COUNTY LAKE	TOTAL SHEETS 677	SHEET NO. 388
BE-800		CONTRACT NO. 60L77		
FED. ROAD DIST. NO. 1 ILLINOIS FED. AID PROJECT				

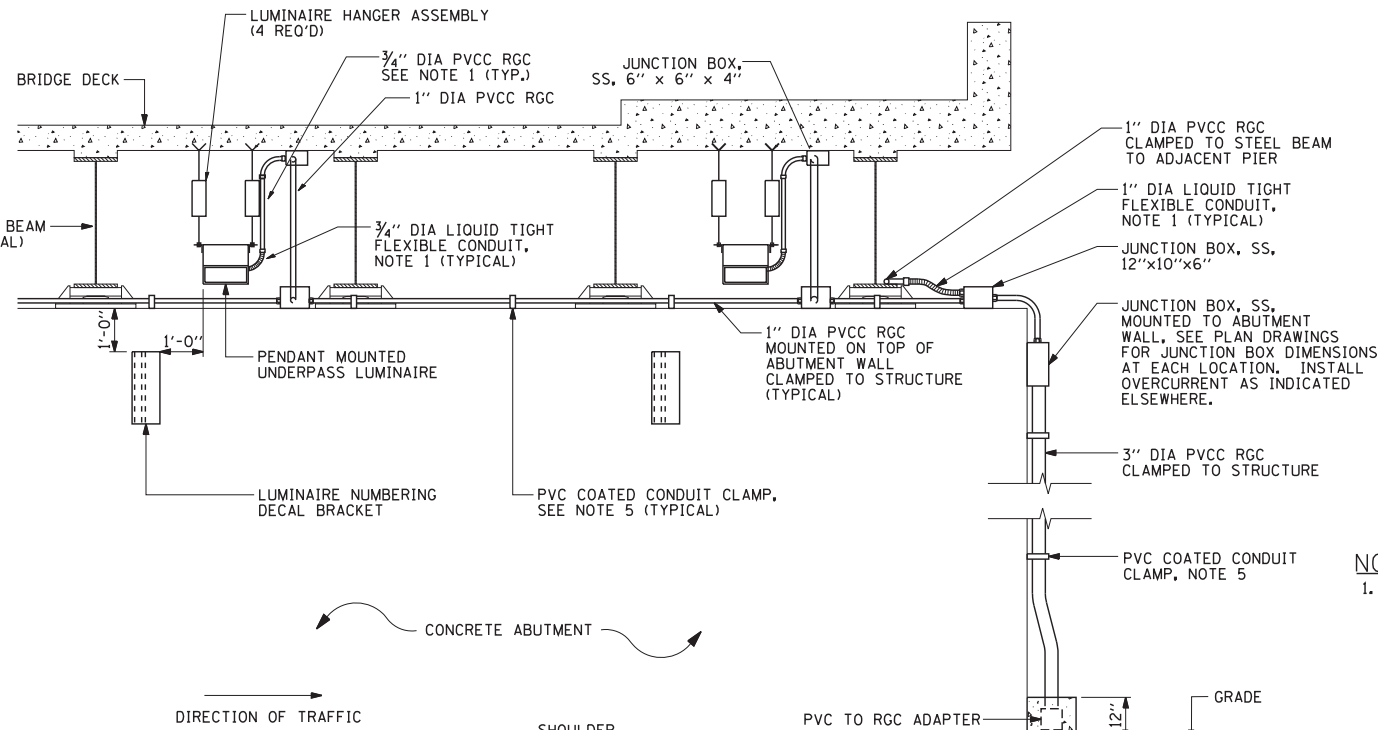
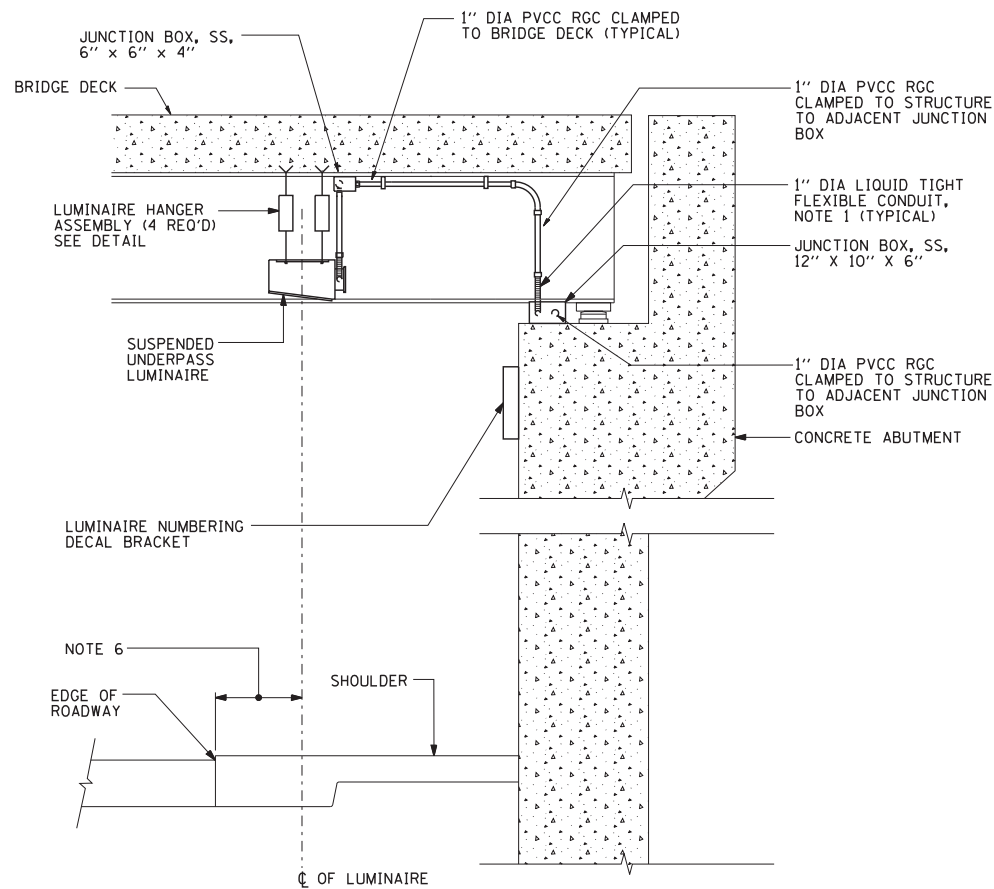

NOTES:

- LIQUID TIGHT FLEXIBLE METAL CONDUIT, MAXIMUM LENGTH 6'-0", TYPICAL FOR EACH INSTANCE AS SHOWN. PROVIDE PVC COATED RIGID GALVANIZED STEEL CONDUIT AS REQUIRED NOT TO EXCEED 6'-0" OF FLEXIBLE LIQUID TIGHT METAL CONDUIT. LIQUID TIGHT FLEXIBLE METAL CONDUIT WILL BE INCLUDED IN THE COST OF THE CONDUIT ATTACHED TO STRUCTURE OF THE CORRESPONDING DIA., GALVANIZED STEEL, PVC COATED PAY ITEM EXCEPT THAT 3/4" DIA. CONDUIT AND 3/4" DIA. FLEXIBLE CONDUIT SHALL BE INCLUDED IN THE COST OF UNDERPASS LUMINAIRE INSTALLATION.
- SEE UNDERPASS LIGHTING PLANS FOR INSTALLATION LOCATION OF UNDERPASS LIGHTING LUMINAIRES.
- THE CONTRACTOR SHALL USE APPROVED SINGLE COIL FLARED LOOP INSERTS WHEN SUSPENDED MOUNTING AN UNDERPASS LUMINAIRE TO A NEW BRIDGE DECK. THE FLARED LOOP INSERTS MUST BE CAST INTO THE CONCRETE DECK. THE CONTRACTOR IS RESPONSIBLE FOR LOCATING AND COORDINATING THE INSERT LOCATIONS FOR MOUNTING THE UNDERPASS LIGHTING SYSTEM AS SHOWN ON THE PLANS WITH THE BRIDGE DECK CONTRACTOR. SEE DETAIL.
- THE UNDERPASS LUMINAIRE HANGER ASSEMBLY COMPLETE WITH HEAVY DUTY ANCHORS/INSERTS AND ALL APPLICABLE HARDWARE SHALL BE INCLUDED IN THE COST OF THE UNDERPASS LUMINAIRE PAY ITEM.
- SECURE THE CONDUIT WITH PVC COATED CONDUIT CLAMPS OR CONDUIT BEAM CLAMPS AS SHOWN AT 5'-0" INTERVALS FOR LATERALS AND WITHIN 2'-0" MAXIMUM FROM ANY JUNCTION BOX, FLEXIBLE CONDUIT, OR CHANGE IN DIRECTION. ALL PVC COATED CONDUIT CLAMPS OR BEAM CLAMPS SHALL BE INCLUDED WITH THE COST OF THE "CONDUIT ATTACHED TO STRUCTURE OF THE CORRESPONDING DIA., GALVANIZED STEEL, PVC COATED" PAY ITEM.
- ALL UNDERPASS LUMINAIRES MUST BE CENTERED IN THE BEAM SPACE AS INDICATED ON THE PLANS UNLESS OTHERWISE DIRECTED BY THE ENGR. LUMINAIRE SETBACK SHALL BE AS INDICATED IN PLANS FOR EACH SPECIFIC UNDERPASS
- THE CONCRETE ENCASED CONDUIT TRANSITION SHALL BE INCLUDED IN THE COST OF THE GALVANIZED RIGID STEEL CONDUIT PAY ITEMS.
- ALL CONDUIT ATTACHED TO STRUCTURE SHALL BE PVC COATED RIGID STEEL CONDUIT (PVCC RGC) TYPICAL.

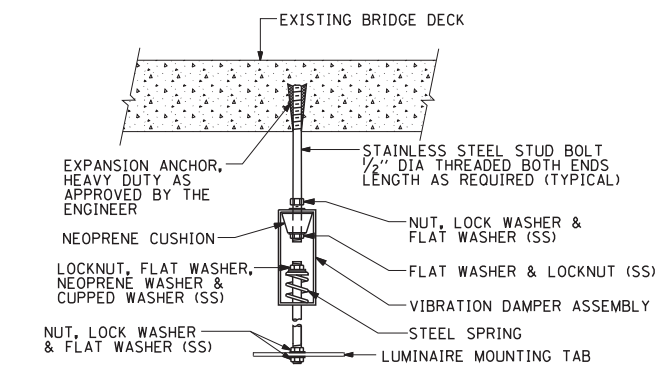

EXISTING BRIDGE DECK INSTALLATION

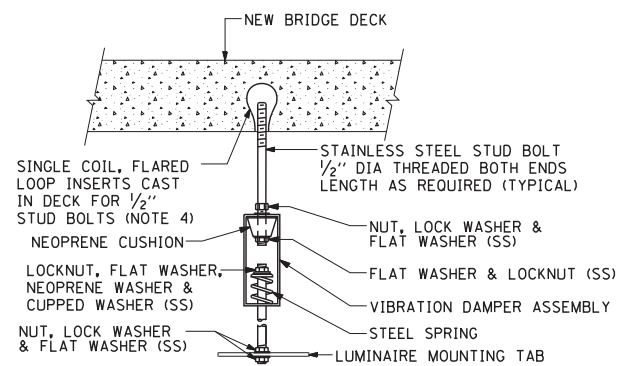

NEW BRIDGE DECK INSTALLATION

TYPICAL LUMINAIRE HANGER ASSEMBLY DETAILS

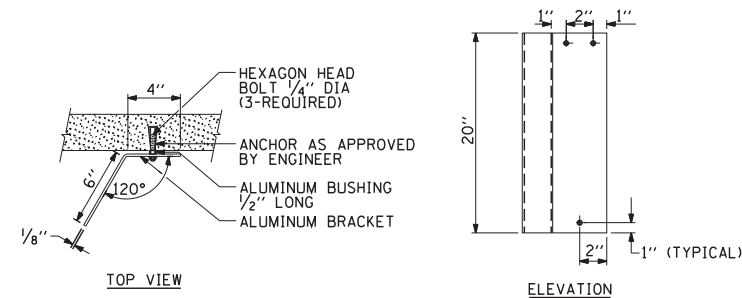

LUMINAIRE NUMBERING DECAL BRACKET NOT TO SCALE

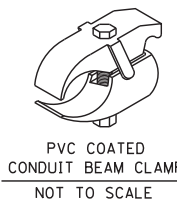

FILE NAME = W:\diststd\22x34\be900.dgn	USER NAME = gaglionobt	DESIGNED -	REVISED - 12-12-05
		DRAWN -	REVISED -
	PLOT SCALE = 50.000' / IN.	CHECKED -	REVISED -
	PLOT DATE = 1/4/2008	DATE -	REVISED -

















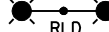

**STATE OF ILLINOIS
DEPARTMENT OF TRANSPORTATION**

**SUSPENDED MOUNT UNDERPASS
LUMINAIRE INSTALLATION DETAILS**

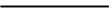
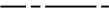
SCALE: NONE SHEET NO. 29 OF 53 SHEETS STA. TO STA.

F.A. RTE. 94	SECTION 49-1R-1	COUNTY LAKE	TOTAL SHEETS 677	SHEET NO. 389
BE-900		CONTRACT NO. 60L77		
FED. ROAD DIST. NO. 1 ILLINOIS FED. AID PROJECT				



TOLLWAY LEGEND

-  EXISTING SINGLE ARM LIGHT POLE TO REMAIN
-  EXISTING DUAL ARM LIGHT POLE TO REMAIN
-  TEMPORARY WOOD POLE, 60 FT.
-  TEMPORARY WOOD POLE, 60 FT., 15FT. MAST ARM, WITH 400 WATT HPS LUMINAIRE, TYPE M-C-II, 480 V (PHASE TO PHASE) MOUNTING HEIGHT AS SPECIFIED.
-  EXISTING LIGHT POLE TO BE RELOCATED
-  EXISTING LIGHT POLE AND FOUNDATION TO BE REMOVED
-  EXISTING OUTDOOR ROADWAY LIGHTING CONSOLE
-  EXISTING HANDHOLE TO BE REMOVED
-  PROPOSED TOLLWAY HANDHOLE
-  RELOCATED SINGLE ARM LIGHT POLE
-  RELOCATED DUAL ARM LIGHT POLE
-  UNIT DUCT OR CONDUIT TAG, SEE CONDUIT AND CABLE SCHEDULE FOR DESCRIPTION
-  NEW UNIT DUCT OR CONDUIT IN CASING
-  EXISTING CONDUIT
-  NEW UNIT DUCT OR CONDUIT
-  TEMPORARY AERIAL CABLE, AS NOTED ON PLANS
-  EXISTING UNDERPASS LUMINAIRE
-  NEW UNDERPASS LUMINAIRE, 150W
-  REMOVE UNDERPASS LUMINAIRE
-  EXISTING JUNCTION BOX
-  NEW JUNCTION BOX, SIZE AND TYPE PER PLANS

TOLLWAY LIGHTING SCHEDULE OF QUANTITIES

CODE NO.	ITEM	UNIT	QUANTITY
81028390	UNDERGROUND CONDUIT, PVC, 4" DIA.	FOOT	80
81200270	CONDUIT EMBEDDED IN STRUCTURE, 4" DIA., PVC	FOOT	194
84400105	RELOCATE EXISTING LIGHTING UNIT	EACH	19
89502380	REMOVE EXISTING HANDHOLE	EACH	1
JS811032	CONDUIT ATTACHED TO STRUCTURE, 1" DIA. PVC COATED GALVANIZED STEEL	FOOT	244
JS813001	JUNCTION BOX, STAINLESS STEEL, EMBEDDED IN STRUCTURE, 20" X 12" X 8"	EACH	1
JS813022	JUNCTION BOX, STAINLESS STEEL, ATTACHED TO STRUCTURE, 6" X 6" X 4"	EACH	10
JS813073	JUNCTION BOX, STAINLESS STEEL, ATTACHED TO STRUCTURE, 16" X 14" X 6"	EACH	1
JS814001	HANDHOLE, TOLLWAY	EACH	1
JS816074	UNIT DUCT, WITH 2-1/C NO. 4 AND 1/C NO. 6 GROUND, 600V (XLP-TYPE USE), 2" DIA. CNC	FOOT	891
JS816078	UNIT DUCT, WITH 4-1/C NO. 4 AND 1/C NO. 6 GROUND, 600V (XLP-TYPE USE), 2" DIA. CNC	FOOT	2923
JS817211	ELECTRIC CABLE IN CONDUIT, 600V (XLP-TYPE USE) 1/C NO. 10	FOOT	1356
JS821002	UNDERPASS LUMINAIRE, 150 WATT, HIGH PRESSURE SODIUM VAPOR	EACH	10
JS836001	LIGHT POLE FOUNDATION (ROADWAY) STEEL HELIX (7 FT) OR CONCRETE	EACH	18
JS836005	LIGHT POLE FOUNDATION (ROADWAY) MEDIAN, TYPE 1	EACH	1
JS842080	REMOVAL OF EXISTING LIGHTING UNIT, SALVAGE	EACH	1
JS842100	REMOVAL OF UNDERPASS LUMINAIRE	EACH	6
JS842105	POLE FOUNDATION, REMOVED	EACH	20
JS846001	MAINTAIN LIGHTING SYSTEM	L SUM	1
X8140115	HANDHOLE TO BE ADJUSTED	EACH	2
	UNIT DUCT, WITH 4-1/C NO. 2 AND 1/C NO. 4 GROUND, 600V (XLP-TYPE USE), 2" DIA. CNC	FOOT	836

TOLLWAY CONDUIT TAGS:

- | TAG | DESCRIPTION |
|---|---|
|  | 2" DIA. UNIT DUCT WITH 4-1/C NO. 4, 1-1/C NO. 6 GND |
|  | 2" DIA. UNIT DUCT WITH 2-1/C NO. 4, 1-1/C NO. 6 GND |
|  | 2" DIA. UNIT DUCT WITH 4-1/C NO. 2, 1-1/C NO. 4 GND |

GENERAL NOTES:

- TOLLWAY LIGHTING WORK SHALL BE IN ACCORDANCE WITH THE IDOT STANDARD SPECIFICATIONS FOR ROAD AND BRIDGE CONSTRUCTION AND THE TOLLWAY SUPPLEMENTAL SPECIFICATIONS TO SAME.
- EXISTING LIGHTING UNITS TO BE RELOCATED ARE TO BE REINSTALLED ON A NEW FOUNDATION AND OPERATIONAL BY DUSK OF THE SAME WORKING DAY.

CALL-OUT LEGEND

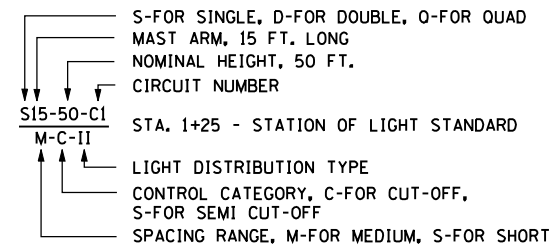

s:\projects\2012\11-173 - bba\p\0\set work\disciplines\electrical\sheet\lighting\30.dgn

EJM ENGINEERING, INC.
411 South Wells Street Suite 1000
Chicago, Illinois 60607

FILE NAME	USER NAME = rsonson	DESIGNED - RAS	REVISED -
		DRAWN - BHH	REVISED -
		CHECKED - MKR	REVISED -
		DATE - 6/19/2012	REVISED -

**STATE OF ILLINOIS
DEPARTMENT OF TRANSPORTATION**

**TOLLWAY LIGHTING GENERAL NOTES AND LEGEND
I-94 FROM ROSECRANS RD TO STATE LINE**

SCALE: NONE SHEET NO. 30 OF 53 SHEETS STA. TO STA.

F.A. RTE.	SECTION	COUNTY	TOTAL SHEETS	SHEET NO.
94	49-1-R-1	LAKE	677	390
ILLINOIS FED. AID PROJECT			CONTRACT NO. 60L77	

NOTES
 1. ALL LIGHTING SHOWN ON THIS SHEET IS TOLLWAY-MAINTAINED.

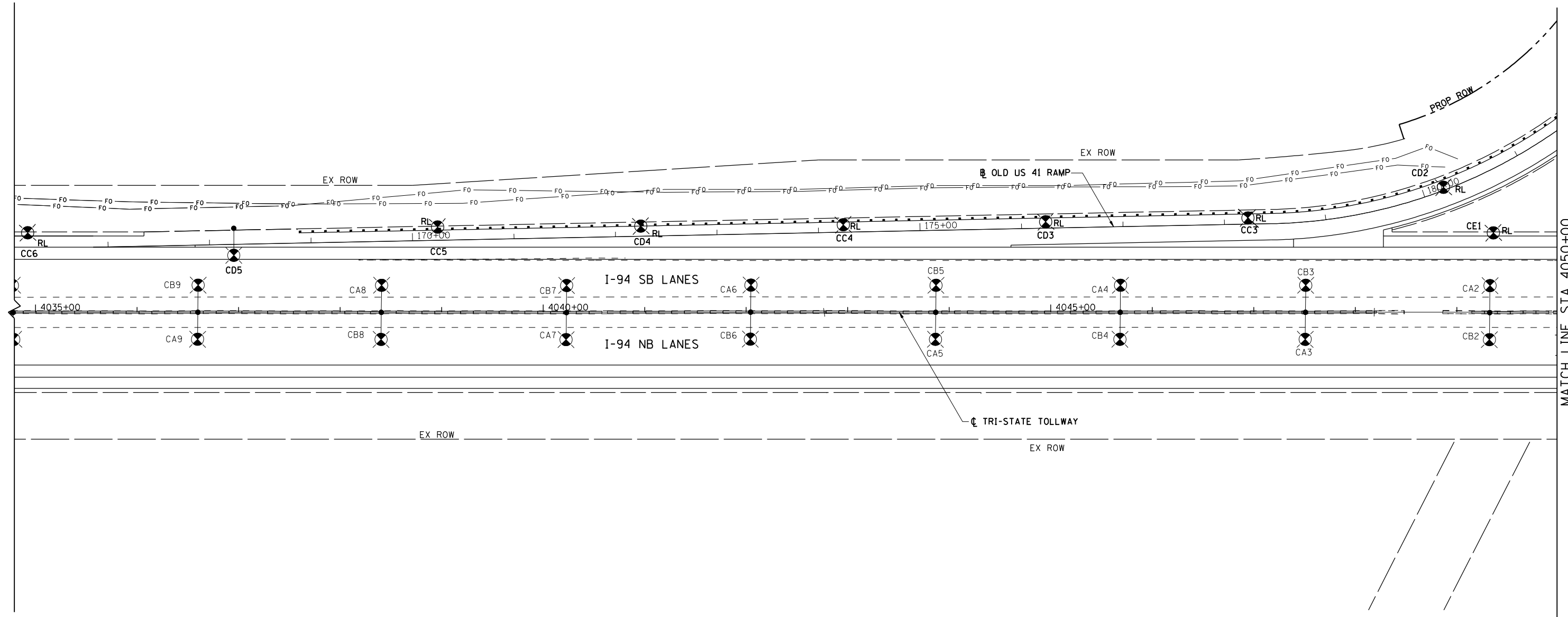
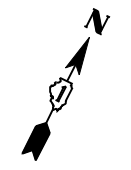

MATCH LINE STA 4050+00
 SEE SHEET E-32

s:\projects\2012\us_41\misc to il 173 - bba\proj\set work\disciplines\electrical\sheet\173-eh-1-light-31.dgn

EJM ENGINEERING, INC.
 411 South Wells Street Suite 1000
 Chicago, Illinois 60607

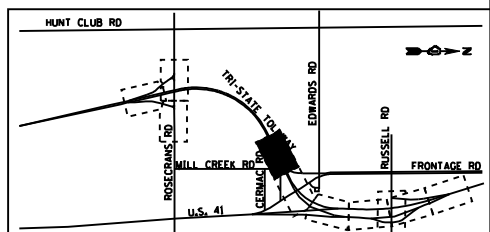
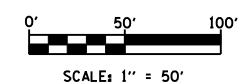

E-31

FILE NAME	USER NAME = rsonson	DESIGNED - RAS	REVISED -
		DRAWN - BHH	REVISED -
	PLOT SCALE = 100.0000' / IN.	CHECKED - MKR	REVISED -
	PLOT DATE = 6/18/2012	DATE - 6/19/2012	REVISED -

**STATE OF ILLINOIS
 DEPARTMENT OF TRANSPORTATION**

**TOLLWAY LIGHTING AND RELOCATION PLAN
 I-94 FROM ROSECRANS RD TO STATE LINE**

SCALE: 1"=50' SHEET NO. 31 OF 53 SHEETS STA. 4035+00 TO STA. 4050+00

F.A. RTE.	SECTION	COUNTY	TOTAL SHEETS	SHEET NO.
94	49-1-R-1	LAKE	677	391
CONTRACT NO. 60L77				
ILLINOIS FED. AID PROJECT				

s:\projects\2012\11-1173 - bba\proj\set\work\disciplines\electrical\sheet\0166-77-sh1-light-32.dgn

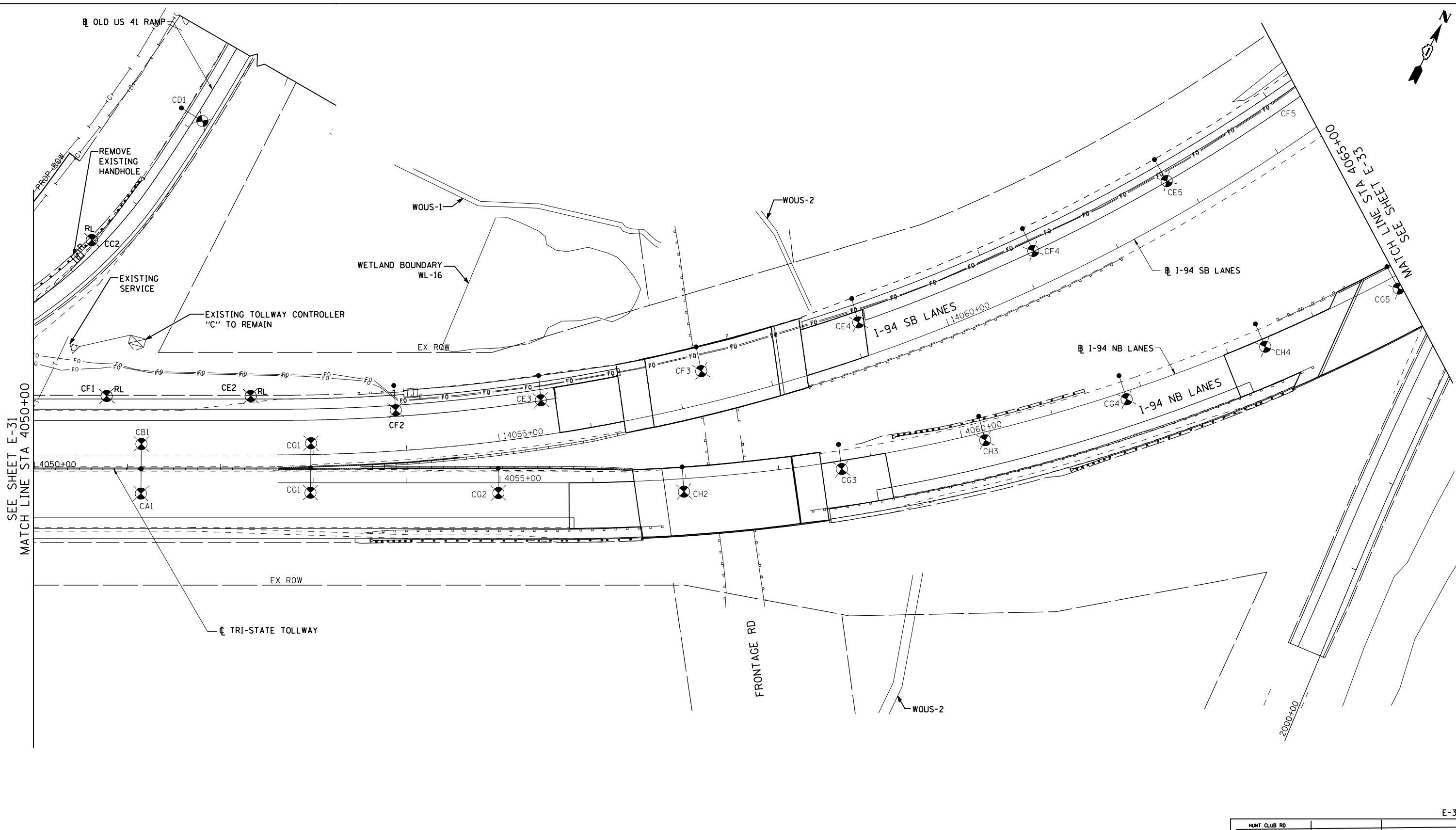

NOTES
 1. ALL LIGHTING SHOWN ON THIS SHEET IS TOLLWAY-MAINTAINED.

EJM ENGINEERING, INC.
 411 South Wells Street Suite 1000
 Chicago, Illinois 60607

FILE NAME	USER NAME = rsonson	DESIGNED - RAS	REVISED -
		DRAWN - BHH	REVISED -
		CHECKED - MKR	REVISED -
		DATE - 6/19/2012	REVISED -

**STATE OF ILLINOIS
 DEPARTMENT OF TRANSPORTATION**

**TOLLWAY LIGHTING AND RELOCATION PLAN
 I-94 FROM ROSECRANS RD TO STATE LINE**
 SCALE: 1"=50' SHEET NO. 32 OF 53 SHEETS STA. 4050+00 TO STA. 4065+00

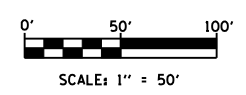

E-32

F.A. RTE.	SECTION	COUNTY	TOTAL SHEETS	SHEET NO.
94	49-1-R-1	LAKE	677	392
CONTRACT NO. 60L77				
ILLINOIS FED. AID PROJECT				

s:\projects\2012\11-41-mse to 11-173 - bba\project\work\disciplines\electrical\sheet\11-41-mse-light-33.dwg

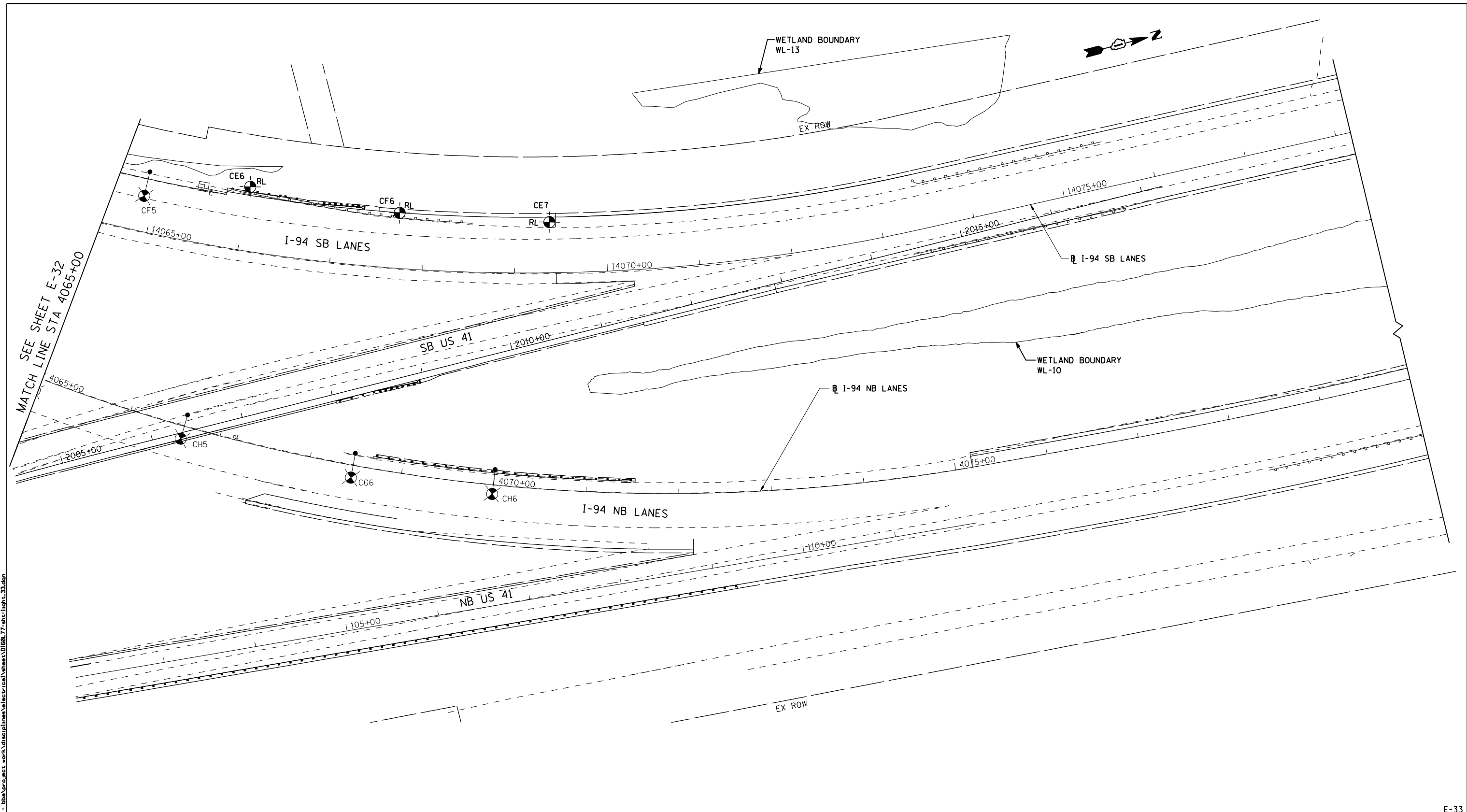

EJM ENGINEERING, INC.
 411 South Wells Street Suite 1000
 Chicago, Illinois 60607

FILE NAME	USER NAME = rsonson	DESIGNED - RAS	REVISED -
		DRAWN - BHH	REVISED -
		CHECKED - MKR	REVISED -
		DATE - 6/19/2012	REVISED -

STATE OF ILLINOIS
DEPARTMENT OF TRANSPORTATION

TOLLWAY LIGHTING AND RELOCATION PLAN
I-94 FROM ROSECRANS RD TO STATE LINE
 SCALE: 1"=50' SHEET NO. 33 OF 53 SHEETS STA. 4065+00 TO STA. 4080+00

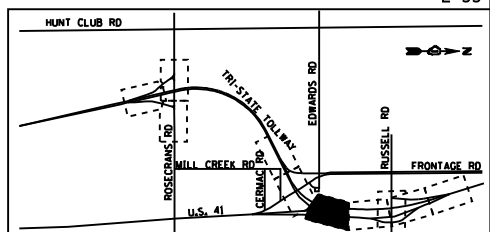
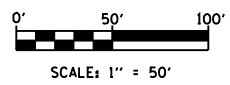

F.A. RTE.	SECTION	COUNTY	TOTAL SHEETS	SHEET NO.
94	49-1-R-1	LAKE	677	393
CONTRACT NO. 60L77				
ILLINOIS FED. AID PROJECT				

E-33

- NOTES:**
- CONNECT EXISTING LIGHT POLE AERIALLY AS SHOWN ON PLAN BEFORE INSTALLING PROPOSED POLE FOUNDATION. AERIAL CABLING SHALL BE TEMPORARILY DISCONNECTED AND RECONNECTED TO ACCOMODATE POLE RELOCATION. SEE SHEET E-40 FOR PROPOSED POLE LOCATION.
 - THE COST OF ALL LABOR, EQUIPMENT, AND MATERIALS (INCLUDING WOOD POLES, AERIAL CABLE, AND ANCILLARIES) REQUIRED TO MAINTAIN OPERATION OF THE EXISTING TOLLWAY LIGHTING SYSTEM IS INCLUDED IN THE PRICE OF THE ITEM "MAINTAIN LIGHTING SYSTEM."

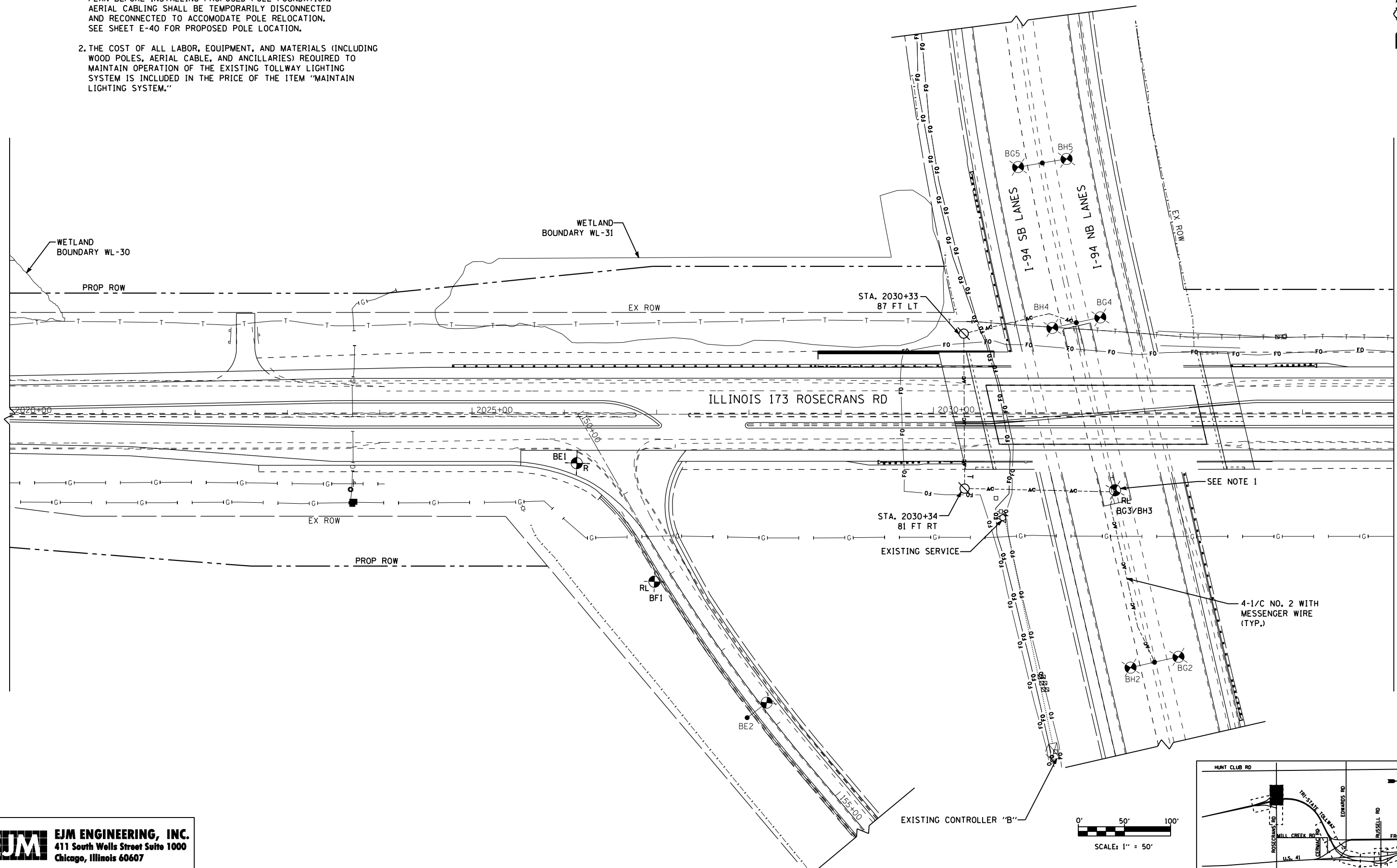

MATCH LINE STA 2035+00
SEE SHEET E-35

s:\projects\2012\11-173 - bba\proj\set work\disciplines\electrical\sheet\1173-light_34.dgn

EJM ENGINEERING, INC.
411 South Wells Street Suite 1000
Chicago, Illinois 60607

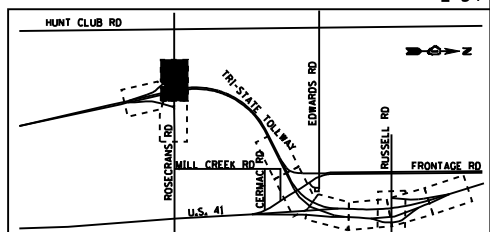
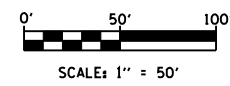

FILE NAME	USER NAME = rsonson	DESIGNED - RAS	REVISED -
		DRAWN - BHH	REVISED -
		CHECKED - MKR	REVISED -
		DATE - 6/19/2012	REVISED -

**STATE OF ILLINOIS
DEPARTMENT OF TRANSPORTATION**

**TOLLWAY LIGHTING AND RELOCATION PLAN
ILLINOIS 173 ROSECRANS RD**

SCALE: 1"=50' SHEET NO. 34 OF 53 SHEETS STA. 2020+00 TO STA. 2035+00

F.A. RTE.	SECTION	COUNTY	TOTAL SHEETS	SHEET NO.
94	49-1-R-1	LAKE	677	394
CONTRACT NO. 60L77				
ILLINOIS FED. AID PROJECT				

E-34



s:\projects\2012 us 41-mse to il 173 - bba\proj\set work\disciplines\electrical\sheet\1173-rlt-light-35.dgn

SEE SHEET E-34
MATCH LINE STA 2035+00

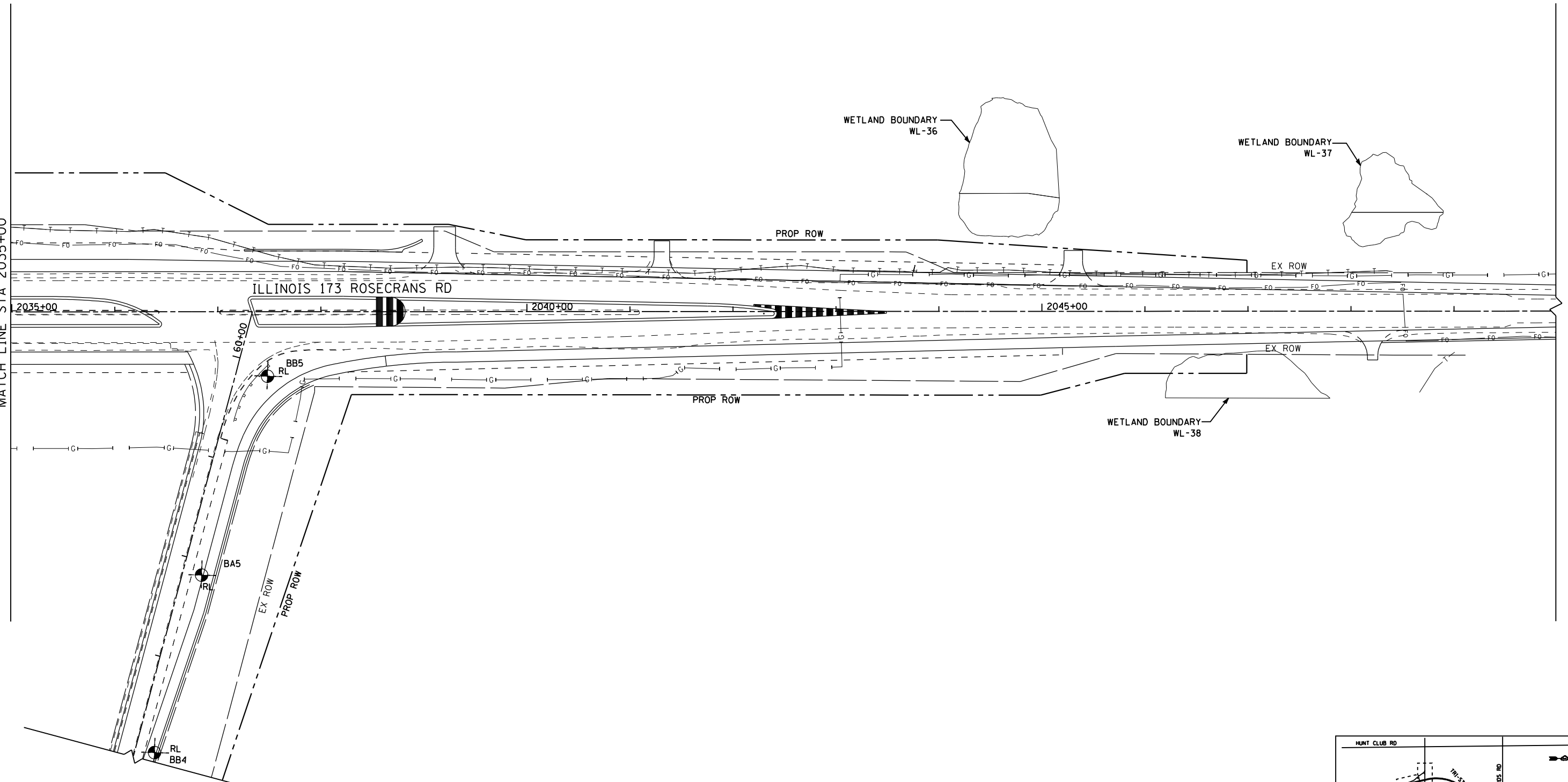

EJM ENGINEERING, INC.
411 South Wells Street Suite 1000
Chicago, Illinois 60607

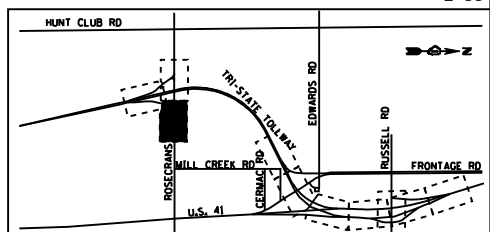
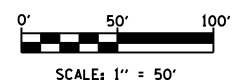

FILE NAME	USER NAME = rsonson	DESIGNED - RAS	REVISED -
		DRAWN - BHH	REVISED -
	PLOT SCALE = 100.0000 / IN.	CHECKED - MKR	REVISED -
	PLOT DATE = 6/18/2012	DATE - 6/19/2012	REVISED -

**STATE OF ILLINOIS
DEPARTMENT OF TRANSPORTATION**

**TOLLWAY LIGHTING AND RELOCATION PLAN
ILLINOIS 173 ROSECRANS RD**

SCALE: 1"=50' SHEET NO. 35 OF 53 SHEETS STA. 2035+00 TO STA. 2050+00

F.A. RTE.	SECTION	COUNTY	TOTAL SHEETS	SHEET NO.
94	49-1-R-1	LAKE	677	395
CONTRACT NO. 60L77				
ILLINOIS FED. AID PROJECT				

E-35

- NOTES:**
- EXISTING LIGHTING UNITS INSTALLED IN TOLLWAY CONTRACTS I-07-5236 AND I-07-5237.
 - EXISTING LIGHTING UNITS TO BE RELOCATED (RLD) ARE SHOWN IN PROPOSED LOCATION.
 - ALL LIGHTING SHOWN ON THIS SHEET IS TOLLWAY-MAINTAINED.
 - ALL OFFSETS AND LIGHT STANDARD FOUNDATIONS FOR GROUND MOUNTED POLES ARE PER TOLLWAY STANDARD DETAIL HI-01, UNLESS NOTED OTHERWISE.

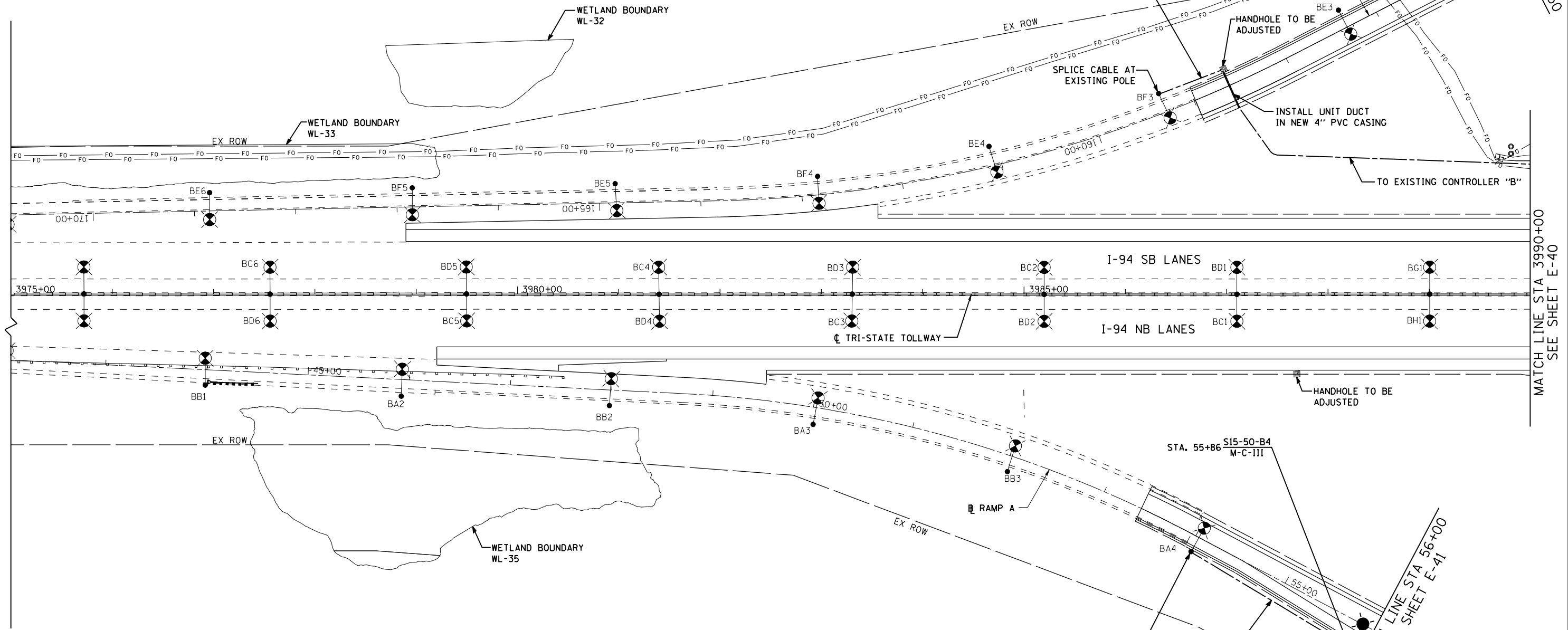

TOLLWAY CONDUIT TAGS:

TAG	DESCRIPTION
(A)	2" DIA. UNIT DUCT WITH 4-1/C NO. 4, 1-1/C NO. 6 GND
(B)	2" DIA. UNIT DUCT WITH 2-1/C NO. 4, 1-1/C NO. 6 GND
(C)	2" DIA. UNIT DUCT WITH 4-1/C NO. 2, 1-1/C NO. 4 GND

EJM ENGINEERING, INC.
 411 South Wells Street Suite 1000
 Chicago, Illinois 60607

FILE NAME	USER NAME = rsonson	DESIGNED - RAS	REVISED -
		DRAWN - BHH	REVISED -
		CHECKED - MKR	REVISED -
		DATE - 6/19/2012	REVISED -

**STATE OF ILLINOIS
 DEPARTMENT OF TRANSPORTATION**

PROPOSED TOLLWAY LIGHTING PLAN			
I-94 FROM ROSECRANS RD TO STATE LINE			
SCALE: 1"=50'	SHEET NO. 36 OF 53 SHEETS	STA. 3975+00 TO STA. 3990+00	

F.A. RTE.	SECTION	COUNTY	TOTAL SHEETS	SHEET NO.
94	49-1-R-1	LAKE	677	396
CONTRACT NO. 60L77				
ILLINOIS FED. AID PROJECT				

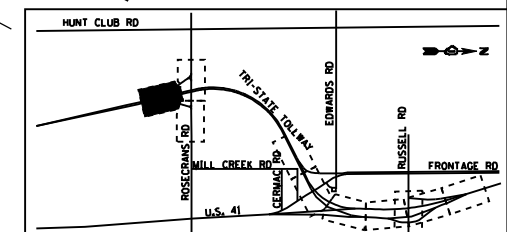
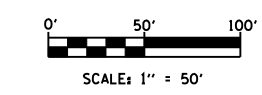

s:\projects\2012\11-173 - bba\proj\set work\disciplines\electrical\sheet\light\light_36.dgn

NOTES:

1. EXISTING LIGHTING UNITS INSTALLED IN TOLLWAY CONTRACTS I-07-5236 AND I-07-5237.
2. EXISTING LIGHTING UNITS TO BE RELOCATED (RLD) ARE SHOWN IN PROPOSED LOCATION.
3. ALL LIGHTING SHOWN ON THIS SHEET IS TOLLWAY-MAINTAINED.
4. ALL OFFSETS AND LIGHT STANDARD FOUNDATIONS FOR GROUND MOUNTED POLES ARE PER TOLLWAY STANDARD DETAIL HI-01, UNLESS NOTED OTHERWISE.

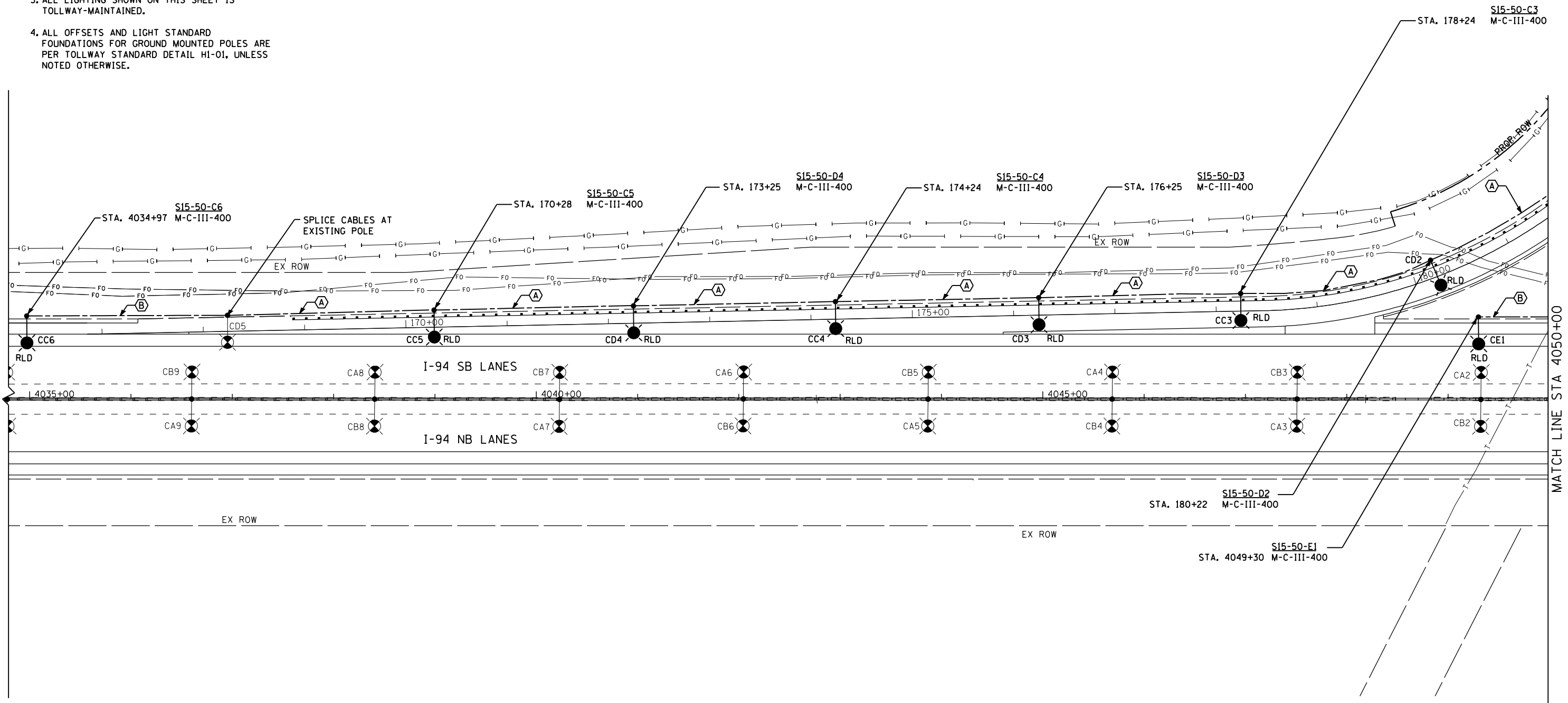

TOLLWAY CONDUIT TAGS:

TAG	DESCRIPTION
(A)	2" DIA. UNIT DUCT WITH 4-1/C NO. 4, 1-1/C NO. 6 GND
(B)	2" DIA. UNIT DUCT WITH 2-1/C NO. 4, 1-1/C NO. 6 GND
(C)	2" DIA. UNIT DUCT WITH 4-1/C NO. 2, 1-1/C NO. 4 GND

EJM ENGINEERING, INC.
 411 South Wells Street Suite 1000
 Chicago, Illinois 60607

FILE NAME	USER NAME = rsonson	DESIGNED - RAS	REVISED -
		DRAWN - BHH	REVISED -
		CHECKED - MKR	REVISED -
		DATE - 6/19/2012	REVISED -

**STATE OF ILLINOIS
 DEPARTMENT OF TRANSPORTATION**

**PROPOSED TOLLWAY LIGHTING PLAN
 I-94 FROM ROSECRANS RD TO STATE LINE**

SCALE: 1"=50' SHEET NO. 37 OF 53 SHEETS STA. 4035+00 TO STA. 4050+00

E-37

F.A. RTE.	SECTION	COUNTY	TOTAL SHEETS	SHEET NO.
94	49-1-R-1	LAKE	677	397

CONTRACT NO. 60L77
 ILLINOIS FED. AID PROJECT

s:\projects\2012\11-173 - bba\proj\set work\disciplines\electrical\sheet\1173-light-37.dwg

MATCH LINE STA 4050+00
 SEE SHEET E-38

- NOTES:**
- EXISTING LIGHTING UNITS INSTALLED IN TOLLWAY CONTRACTS I-07-5236 AND I-07-5237.
 - EXISTING LIGHTING UNITS TO BE RELOCATED (RLD) ARE SHOWN IN PROPOSED LOCATION.
 - ALL LIGHTING SHOWN ON THIS SHEET IS TOLLWAY-MAINTAINED.
 - ALL OFFSETS AND LIGHT STANDARD FOUNDATIONS FOR GROUND MOUNTED POLES ARE PER TOLLWAY STANDARD DETAIL HI-01, UNLESS NOTED OTHERWISE.

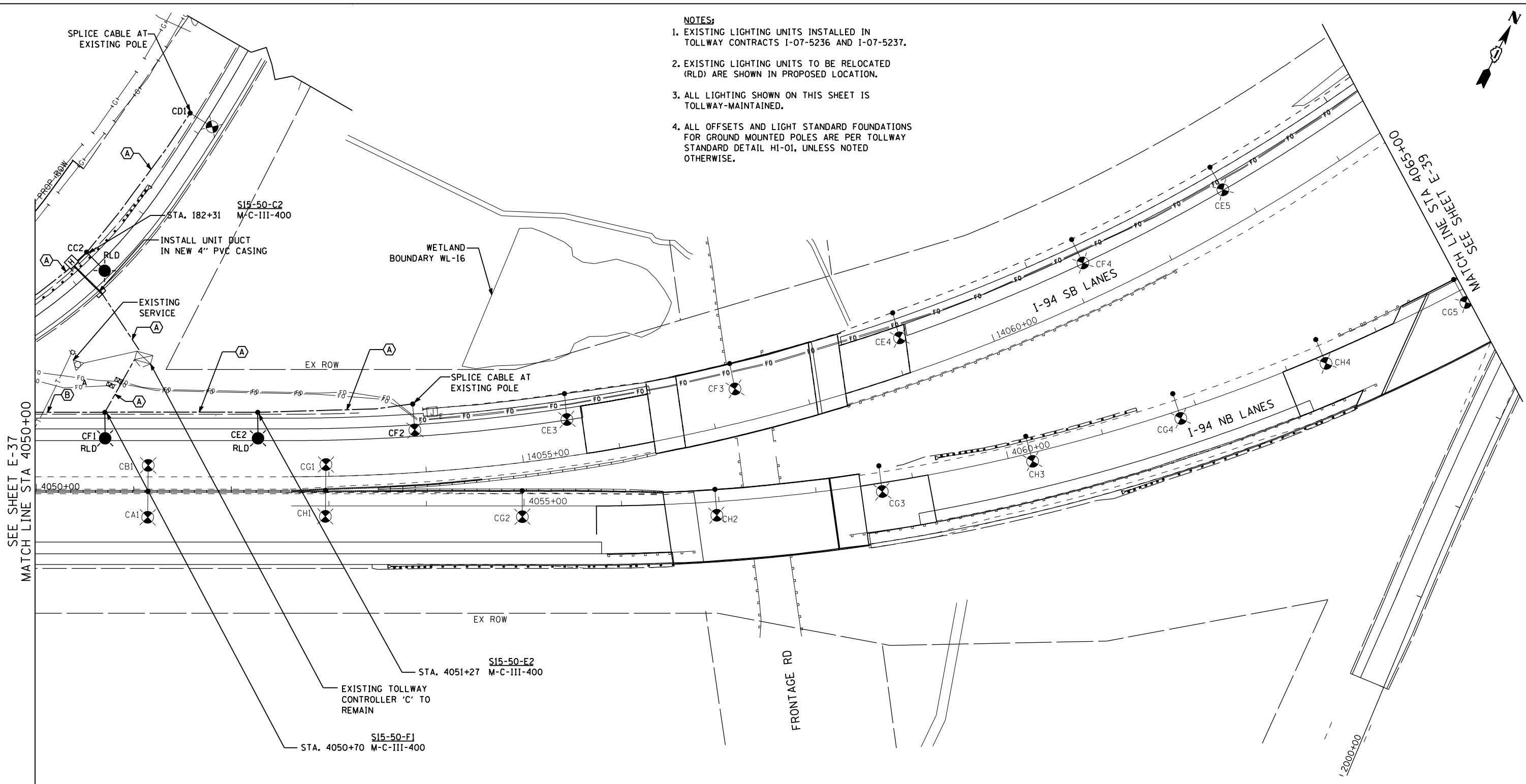

TOLLWAY CONDUIT TAGS:

TAG	DESCRIPTION
(A)	2" DIA. UNIT DUCT WITH 4-1/C NO. 4, 1-1/C NO. 6 GND
(B)	2" DIA. UNIT DUCT WITH 2-1/C NO. 4, 1-1/C NO. 6 GND
(C)	2" DIA. UNIT DUCT WITH 4-1/C NO. 2, 1-1/C NO. 4 GND

EJM ENGINEERING, INC.
 411 South Wells Street Suite 1000
 Chicago, Illinois 60607

FILE NAME	USER NAME = rsonson	DESIGNED - RAS	REVISED -
		DRAWN - BHH	REVISED -
	PLOT SCALE = 100.0000' / IN.	CHECKED - MKR	REVISED -
	PLOT DATE = 6/18/2012	DATE - 6/19/2012	REVISED -

**STATE OF ILLINOIS
 DEPARTMENT OF TRANSPORTATION**

**PROPOSED TOLLWAY LIGHTING PLAN
 I-94 FROM ROSECRANS RD TO STATE LINE**

SCALE: 1"=50' SHEET NO. 38 OF 53 SHEETS STA. 4050+00 TO STA. 4065+00

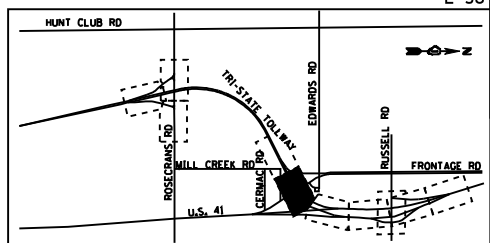
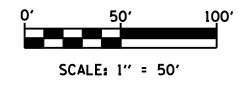

F.A. RTE.	SECTION	COUNTY	TOTAL SHEETS	SHEET NO.
94	49-1-R-1	LAKE	677	398
CONTRACT NO. 60L77				
ILLINOIS FED. AID PROJECT				

s:\projects\2012\11-1173 - bba\proj\set\work\disciplines\electrical\sheet\060677-ht-light_38.dwg

s:\projects\2012\11-173 - bba\proj\met_work\disciplines\electrical\sheet\1173-1173-light_39.dwg

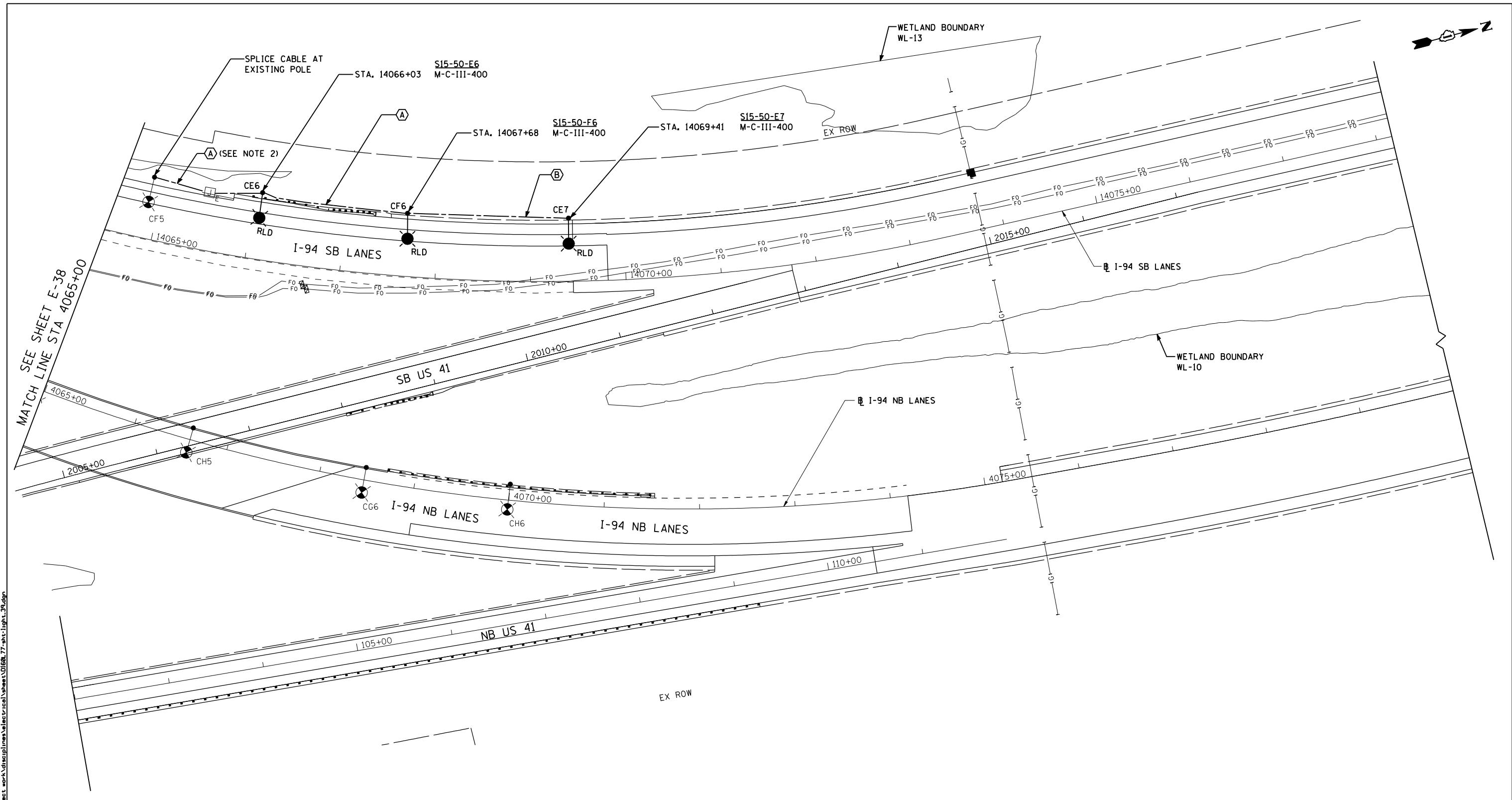

- NOTES:**
1. ALL OFFSETS AND LIGHT STANDARD FOUNDATIONS FOR GROUND MOUNTED POLES ARE PER TOLLWAY STANDARD DETAIL HI-01, UNLESS NOTED OTHERWISE.
 2. INSTALL UNIT DUCT IN EXISTING 2" EMBEDDED CONDUIT BETWEEN POLE CF5 AND EXISTING JUNCTION BOX. REMOVAL OF THE EXISTING UNIT DUCT IS INCLUDED IN THE COST OF THE NEW UNIT DUCT.

- TOLLWAY CONDUIT TAGS:**
- | TAG | DESCRIPTION |
|-----|---|
| (A) | 2" DIA. UNIT DUCT WITH 4-1/C NO. 4, 1-1/C NO. 6 GND |
| (B) | 2" DIA. UNIT DUCT WITH 2-1/C NO. 4, 1-1/C NO. 6 GND |
| (C) | 2" DIA. UNIT DUCT WITH 4-1/C NO. 2, 1-1/C NO. 4 GND |

EJM ENGINEERING, INC.
 411 South Wells Street Suite 1000
 Chicago, Illinois 60607

FILE NAME	USER NAME = rsonson	DESIGNED - RAS	REVISED -
		DRAWN - BHH	REVISED -
	PLOT SCALE = 100.0000' / IN.	CHECKED - MKR	REVISED -
	PLOT DATE = 6/18/2012	DATE - 6/19/2012	REVISED -

**STATE OF ILLINOIS
 DEPARTMENT OF TRANSPORTATION**

**PROPOSED TOLLWAY LIGHTING PLAN
 I-94 FROM ROSECRANS RD TO STATE LINE**

SCALE: 1"=50' SHEET NO. 39 OF 53 SHEETS STA. 4065+00 TO STA. 4080+00

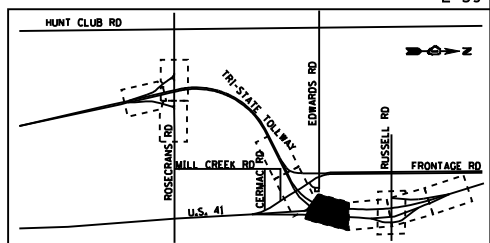
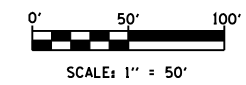

F.A. RTE.	SECTION	COUNTY	TOTAL SHEETS	SHEET NO.
94	49-1-R-1	LAKE	677	399
CONTRACT NO. 60L77				
ILLINOIS FED. AID PROJECT				

TOLLWAY CONDUIT TAGS:

TAG	DESCRIPTION
(A)	2" DIA. UNIT DUCT WITH 4-1/C NO. 4, 1-1/C NO. 6 GND
(B)	2" DIA. UNIT DUCT WITH 2-1/C NO. 4, 1-1/C NO. 6 GND
(C)	2" DIA. UNIT DUCT WITH 4-1/C NO. 2, 1-1/C NO. 4 GND

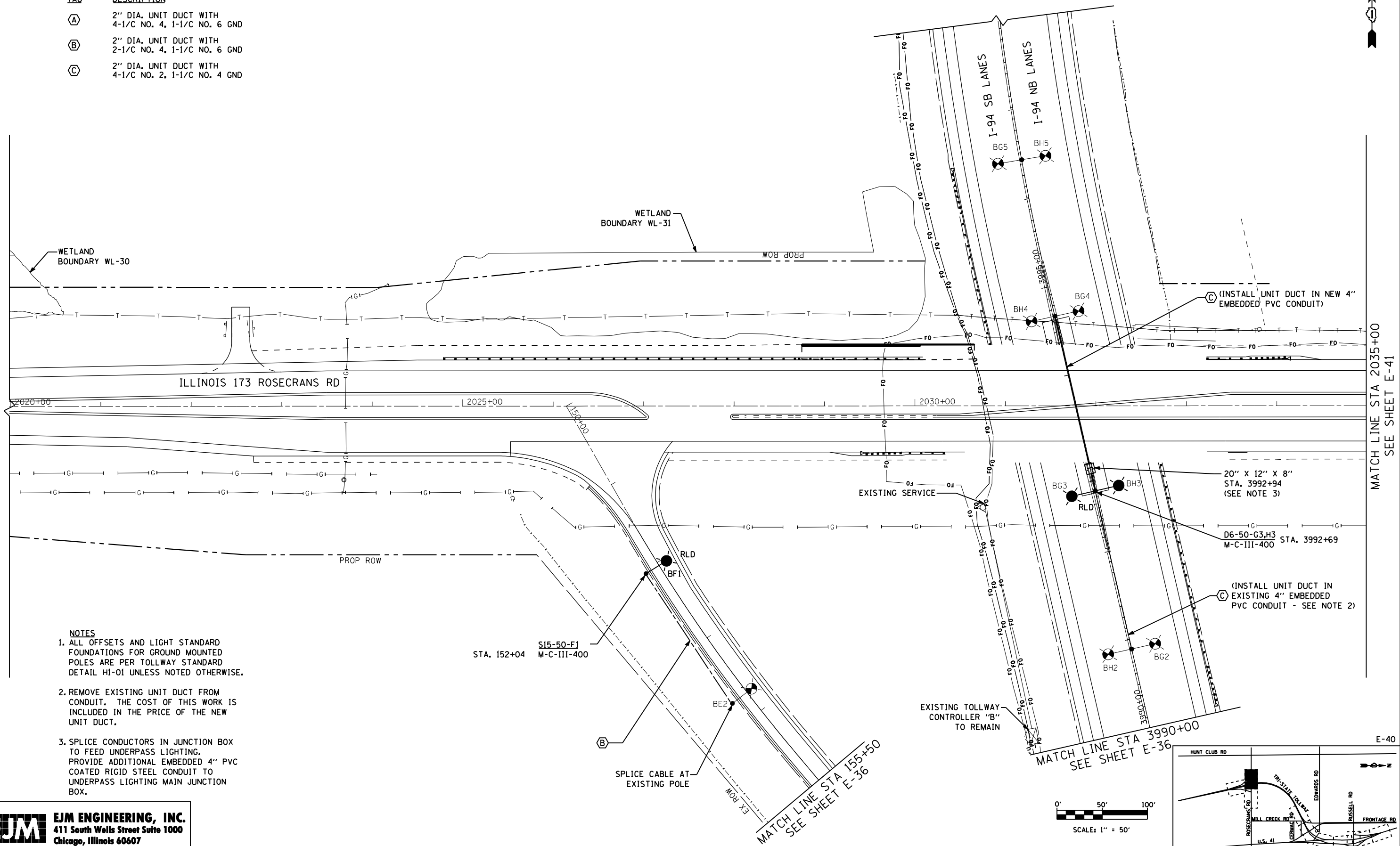

- NOTES**
- ALL OFFSETS AND LIGHT STANDARD FOUNDATIONS FOR GROUND MOUNTED POLES ARE PER TOLLWAY STANDARD DETAIL HI-01 UNLESS NOTED OTHERWISE.
 - REMOVE EXISTING UNIT DUCT FROM CONDUIT. THE COST OF THIS WORK IS INCLUDED IN THE PRICE OF THE NEW UNIT DUCT.
 - SPLICE CONDUCTORS IN JUNCTION BOX TO FEED UNDERPASS LIGHTING. PROVIDE ADDITIONAL EMBEDDED 4" PVC COATED RIGID STEEL CONDUIT TO UNDERPASS LIGHTING MAIN JUNCTION BOX.

s:\projects\2011 us 41 - msc to il 173 - bba\proj\set work\disciplines\electrical\sheet\1173-light-40.dwg

EJM ENGINEERING, INC.
 411 South Wells Street Suite 1000
 Chicago, Illinois 60607

FILE NAME	USER NAME = rsonson	DESIGNED - RAS	REVISED -
		DRAWN - BHH	REVISED -
		CHECKED - MKR	REVISED -
		DATE - 6/19/2012	REVISED -

**STATE OF ILLINOIS
 DEPARTMENT OF TRANSPORTATION**

**PROPOSED TOLLWAY LIGHTING PLAN
 ILLINOIS 173 ROSECRANS RD**

SCALE: 1" = 50' SHEET NO. 40 OF 53 SHEETS STA. 2020+00 TO STA. 2035+00

E-40

F.A. RTE.	SECTION	COUNTY	TOTAL SHEETS	SHEET NO.
94	49-1-R-1	LAKE	677	400

CONTRACT NO. 60L77
 ILLINOIS FED. AID PROJECT