



PLAN

CONCRETE FOUNDATION GRADING PLAN WITH FRONT SLOPES

NOTES:

1. AT LOCATIONS NOT SHIELDED BY GUARDRAIL, THE SLOPE ADJACENT TO EACH FOUNDATION SHALL BE GRADED LEVEL SO THAT THE LIGHT POLE FOUNDATION IS FLUSH WITH GRADE ON ANY FACE. THE TOP OF THE FOUNDATION SHALL BE AT THE SAME ELEVATION AS THE TOP OF GUTTER OR AGGREGATE SHOULDER.
2. 3/4" PVC CONDUIT IN CONCRETE FOUNDATION FOR NO. 6 BARE COPPER GROUND WIRE.
3. CADWELD NO. 6 BARE COPPER GROUND CABLE TO GROUND ROD.
4. WHERE THE GRADING SLOPES DOWNWARD THE AREA BEHIND EACH LIGHT POLE FOUNDATION SHALL BE GRADED LEVEL FOR 5' BEFORE SLOPING DOWN.
5. THE LEVEL AREA SHALL EXTEND PARALLEL TO THE ROADWAY 10' ON EITHER SIDE OF THE LIGHT POLE FOUNDATION.
6. ALL SLOPES ARE EXPRESSED AS UNITS OF VERTICAL DISPLACEMENT TO UNITS OF HORIZONTAL DISPLACEMENT (V:H).
7. ALL GROUND MOUNTED LIGHT POLES SHALL BE PROVIDED WITH AN ACCEPTED FHWA BREAKAWAY BASE OR DEVICE.
8. THE MINIMUM LIGHT POLE SETBACK DISTANCE FROM EDGE OF ROADWAY TO CL OF POLE AND FOUNDATION SHALL BE 11'-0" WHEN THE PAVED SHOULDER WIDTH IS LESS THAN 10'-0".

 APPROVED: CHIEF ENGINEER DATE 2-7-2012 ...

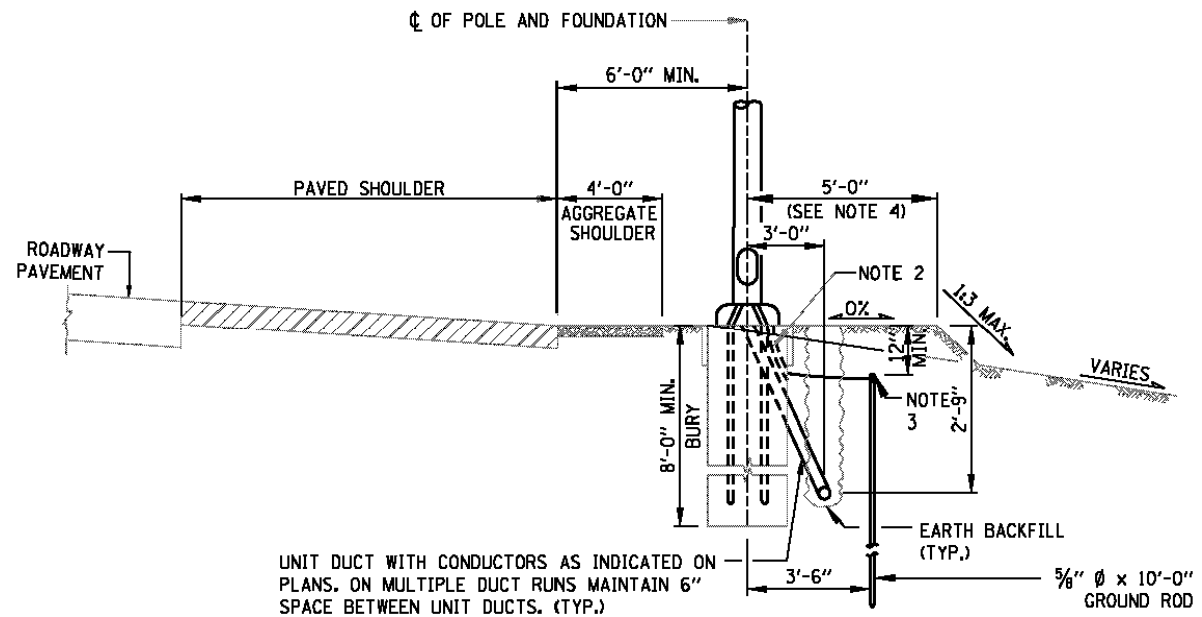

CONCRETE FOUNDATION ADJACENT TO AGGREGATE SHOULDER WITH FORESLOPE

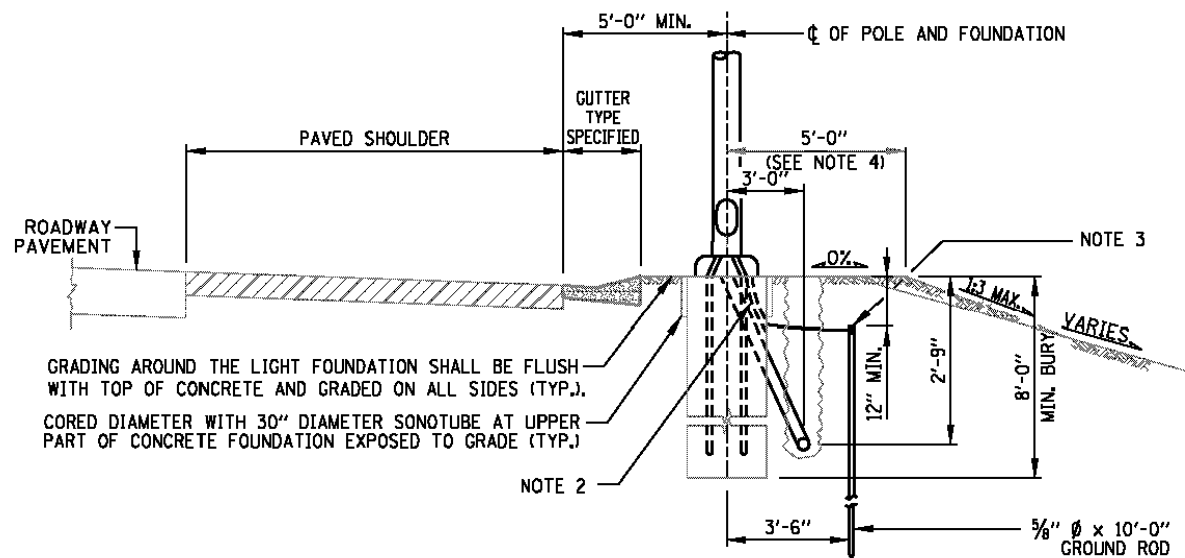

CONCRETE FOUNDATION ADJACENT TO GUTTER WITH FORESLOPE

SHEET 1 OF 6



DATE	REVISIONS
2-7-2012	MODIFIED FOUNDATION DETAILS, REVISED
	NOTES

LIGHT STANDARD FOUNDATION
 STANDARD H1-01

EJM ENGINEERING, INC.
 411 South Wells Street Suite 1000
 Chicago, Illinois 60607

FILE NAME	USER NAME: rsonson	DESIGNED - RAS	REVISED -
		DRAWN - BHH	REVISED -
		CHECKED - MKR	REVISED -
		DATE - 6/19/2012	REVISED -

STATE OF ILLINOIS
 DEPARTMENT OF TRANSPORTATION

TOLLWAY STANDARD DRAWINGS

SCALE: NONE SHEET NO. 46 OF 53 SHEETS STA. TO STA.

F.A. RTE.	SECTION	COUNTY	TOTAL SHEETS	SHEET NO.
94	49-1-R-1	LAKE	677	406
CONTRACT NO. 60L77				
ILLINOIS FED. AID PROJECT				

E-46