

INSTRUCTIONS

ABOUT IDOT PROPOSALS: All proposals are potential bidding proposals. Each proposal contains all certifications and affidavits, a proposal signature sheet and a proposal bid bond.

PREQUALIFICATION

Any contractor who desires to become pre-qualified to bid on work advertised by IDOT must submit the properly completed pre-qualification forms to the Bureau of Construction no later than 4:30 p.m. prevailing time twenty-one days prior to the letting of interest. This pre-qualification requirement applies to first time contractors, contractors renewing expired ratings, contractors maintaining continuous pre-qualification or contractors requesting revised ratings. To be eligible to bid, existing pre-qualification ratings must be effective through the date of the letting.

WHO CAN BID?

Bids will be accepted from only those companies that request and receive written Authorization to Bid from IDOT's Central Bureau of Construction.

REQUESTS FOR AUTHORIZATION TO BID

Contractors wanting to bid on items included in a particular letting must submit the properly completed "Request for Authorization to Bid/or Not For Bid Status" (BDE 124) and the ORIGINAL "Affidavit of Availability: (BC 57) to the proper office no later than 4:30 p.m. prevailing time, three (3) days prior to the letting date.

WHAT CONSTITUTES WRITTEN AUTHORIZATION TO BID?: When a prospective prime bidder submits a "Request for Authorization to Bid or Not for Bid Status" (BDE 124) he/she must indicate at that time which items are being requested For Bidding purposes. Only those items requested For Bidding will be analyzed. After the request has been analyzed, the bidder will be issued an **Authorization to Bid or Not for Bid Report**, approved by the Central Bureau of Construction and the Chief Procurement Officer that indicates which items have been approved For Bidding. If **Authorization to Bid** cannot be approved, the **Authorization to Bid or Not for Bid Report** will indicate the reason for denial.

ABOUT AUTHORIZATION TO BID: Firms that have not received an Authorization to Bid or Not For Bid Report within a reasonable time of complete and correct original document submittal should contact the department as to the status. Firms unsure as to authorization status should call the Prequalification Section of the Bureau of Construction at the number listed at the end of these instructions. These documents must be received three days before the letting date.

ADDENDA AND REVISIONS: It is the bidder's responsibility to determine which, if any, addenda or revisions pertain to any project they may be bidding. Failure to incorporate all relevant addenda or revisions may cause the bid to be declared unacceptable.

Each addendum or revision will be included with the Electronic Plans and Proposals. Addenda and revisions will also be placed on the Addendum/Revision Checklist and each subscription service subscriber will be notified by e-mail of each addendum and revision issued.

The Internet is the Department's primary way of doing business. The subscription server e-mails are an added courtesy the Department provides. It is suggested that bidders check IDOT's website at <http://www.dot.il.gov/desenv/delett.html> before submitting final bid information.

IDOT IS NOT RESPONSIBLE FOR ANY E-MAIL FAILURES.

Addenda questions may be directed to the Contracts Office at (217)782-7806 or D&Econtracts@dot.il.gov

Technical questions about downloading these files may be directed to Tim Garman at (217)524-1624 or Timothy.Garman@illinois.gov.

BID SUBMITTAL GUIDELINES AND CHECKLIST

- All pages should be single sided.
- Use the Cover Page that is provided in the Bid Proposal (posted on the IDOT Web Site) as the first page of your submitted bid. It has the Item number in large bold type in the upper left-hand corner of the page.
- Do not use report covers, presentation folders or special bindings and do not staple multiple times on left side like a book. Use only 1 staple in the upper left hand corner.
- Do not include any certificates of eligibility, your authorization to bid, Addendum Letters or affidavit of availability.
- Do not include the Subcontractor Documentation with your bid (pages 30-38).
- Use the envelope cover sheet (provided with the proposal) as the cover for the proposal envelope.
- Do not rely on overnight services to deliver your proposal prior to 10 AM on letting day. It will not be read if it is delivered after 10 AM.
- Do not submit your Substance Abuse Prevention Program (SAPP) with your bid. If you are awarded the contract this form is to be submitted to the Division Construction Engineer at the pre-construction conference.

BID SUBMITTAL CHECKLIST

Cover page (the sheet that has the item number on it) – This should be the first page of your proposal, **followed by your bid (the Pay Items)**. If you are using special software or CBID to generate your schedule of prices, do not include the blank schedule of prices that came with the proposal package.

Page 4 (Item 10) - Check “YES” if you will use a subcontractor(s) with an annual value over \$50,000. Include the subcontractor(s) name, address, general type of work to be performed and the dollar amount. If you will use subcontractor(s) but are uncertain who or the dollar amount; check “YES” but leave the lines blank.

After Page 4 – Insert the following documents: The **Illinois Office Affidavit** (Not applicable to federally funded projects) followed by Cost Adjustments for Steel, Bituminous, and Fuel (if applicable) and the Contractor Letter of Assent (if applicable). The general rule should be, if you don’t know where it goes, put it after page 4.

Page 10 (Paragraph J) - Check “YES” or “NO” whether your company has any business in Iran.

Page 10 (Paragraph K) – (Not applicable to federally funded projects) List the name of the apprenticeship and training program sponsor holding the certificate of registration from the US Department of Labor. If no applicable program exists, please indicate the work/job category. **Your bid will not be read if this is not completed.** Do not include certificates with your bid. Keep the certificates in your office in case they are requested by IDOT.

Page 11 (Paragraph M) – Indicate if your company has hired a lobbyist in connection with the job for which you are submitting the bid proposal.

Page 12 (Paragraph C) - This is a work sheet to determine if a completed Form A is required. It is not part of the form and you do not need to make copies for each Form A that is filled out.

Pages 14-17 (Form A) - One Form A (4 pages) is required for each applicable person in your company. Copies of the Forms can be used and only need to be changed when the financial information changes. The certification signature and date must be original for each letting. **Do not staple the forms together.** If you answered “NO” to all of the questions in Paragraph C (page 12), complete the first section (page 14) with your company information and then sign and date the Not Applicable statement on page 17.

Page 18 (Form B) - If you check “YES” to having other current or pending contracts it is acceptable to use the phrase, “See Affidavit of Availability on file”. **Ownership Certification** (at the bottom of the page) – Check N/A if the Form A you submitted accounts for 100 percent of the company ownership. Check YES if any percentage of ownership falls outside of the parameters that require reporting on the Form A. Checking NO indicates that the Form A you submitted is not correct and you will be required to submit a revised Form A.

Pages 20-21 (Workforce Projection) - Be sure to include the Duration of the Project. It is acceptable to use the phrase “Per Contract Specifications”.

Bid Bond – (After the Proposal Signature Page) Submit your bid bond (if applicable) using the current Bid Bond Form provided in the proposal package. The Power of Attorney page should be stapled to the Bid Bond. If you are using an electronic bond, include your bid bond number on the form and attach the Proof of Insurance printed from the Surety 2000 Web Site.

Disadvantaged Business Utilization Plan and/or Good Faith Effort - The last item in your bid should be the DBE Utilization Plan (SBE 2026), followed by the DBE Participation Statement (SBE 2025) and supporting paperwork. If you have documentation for a Good Faith Effort, it should follow the SBE Forms.

7A

RETURN WITH BID

Proposal Submitted By	
Name	
Address	
City/State	9 Digit Zip Code
Telephone No.	Fax No.
Federal Employer Identification No. (FEIN)	
Email Address	

Letting August 2, 2013

NOTICE TO PROSPECTIVE BIDDERS

This proposal can be used for bidding purposes by only those companies that request and receive written AUTHORIZATION TO BID from IDOT's Central Bureau of Construction.
BIDDERS NEED NOT RETURN THE ENTIRE PROPOSAL

Notice to Bidders, Specifications, Proposal, Contract and Contract Bond



Illinois Department of Transportation
DIVISION OF AERONAUTICS

Contract No. LK010
Lake in the Hills Airport
Lake in the Hills, Illinois
McHenry County
Illinois Project No. 3CK-4283
SBG Project No. TBD

For engineering information, contact Matthew N. Demos, P.E. of Crawford, Murphy and Tilly, Inc. at (312) 357-2066.

FAA rules prohibit the use of escalation clauses for materials. Therefore, the Division of Aeronautics cannot offer any material cost adjustment provisions for projects that utilize Federal funds.

PLEASE MARK THE APPROPRIATE BOX BELOW:

- A Bid Bond is included.
- A Cashier's Check or a Certified Check is included.



PROPOSAL

TO THE DEPARTMENT OF TRANSPORTATION

1. Proposal of _____

Taxpayer Identification Number (Mandatory) _____

For the improvement identified and advertised for bids in the Invitation for Bids as:

Contract No. LK010
Lake in the Hills Airport
Lake in the Hills, Illinois
McHenry County
Illinois Project No. 3CK-4283
SBG Project No. TBD

Construct Apron for the Fuel Facility and Relocate Fuel Facility

2. The undersigned bidder will furnish all labor, material and equipment to complete the above described project in a good workmanlike manner as provided in the contract documents provided by the Department of Transportation. This proposal will become part of the contract and the terms and conditions contained in the contract documents shall govern performance and payments.
3. **COMPLETION TIME/LIQUIDATED DAMAGES.** It being understood and agreed that the completion within the time limit is an essential part of the contract, the bidder agrees to complete the work within 59 calendar days, unless additional time is granted by the Engineer in accordance with the provisions of the specifications. In case of failure to complete the work on or before the time named herein, or within such extra time as may have been allowed by extensions, the bidder agrees that the Department of Transportation shall withhold from such sum as may be due him/her under the terms of this contract, the costs, as set forth below, which costs shall be considered and treated not as a penalty but as damages due to the State from the bidder by reason of the failure of the bidder to complete the work within the time specified in the contract.

Schedule of Deductions for Each Day of Overrun in Contract Time			
Original Contract Amount		Daily Charges	
From More Than	To and Including	Calendar Day	Work Day
\$ 0	\$ 100,000	\$ 475	\$ 675
100,000	500,000	750	1,050
500,000	1,000,000	1,025	1,425
1,000,000	3,000,000	1,275	1,725
3,000,000	6,000,000	1,425	2,000
6,000,000	12,000,000	2,300	3,450
12,000,000	And over	5,800	8,125

A daily charge shall be made for every day shown on the calendar beyond the specified contract time in calendar days.

RETURN WITH BID

7. COMBINATION BIDS. The undersigned further agrees that if awarded the contract for the sections contained in the following combination, he/she will perform the work in accordance with the requirements of each individual proposal comprising the combination bid specified in the schedule below, and that the combination bid shall be prorated against each section in proportion to the bid submitted for the same. If an error is found to exist in the gross sum bid for one or more of the individual sections included in a combination, the combination bid shall be corrected as provided in the specifications.

When a combination bid is submitted, the schedule below must be completed in each proposal comprising the combination.

If alternate bids are submitted for one or more of the sections comprising the combination, a combination bid must be submitted for each alternate.

Schedule of Combination Bids

Combination No.	Sections Included in Combination	Combination Bid	
		Dollars	Cents

8. SCHEDULE OF PRICES. The undersigned submits herewith, in accordance with the rules and instructions, a schedule of prices for the items of work for which bids are sought. The unit prices bid are in U.S. dollars and cents, and all extensions and summations have been made. The bidder understands that the quantities appearing in the bid schedule are approximate and are provided for the purpose of obtaining a gross sum for the comparison of bids. If there is an error in the extension of the unit prices, the unit prices shall govern. Payment to the contractor awarded the contract will be made only for actual quantities of work performed and accepted or materials furnished according to the contract. The scheduled quantities of work to be done and materials to be furnished may be increased, decreased or omitted as provided elsewhere in the contract.

9. AUTHORITY TO DO BUSINESS IN ILLINOIS. Section 20-43 of the Illinois Procurement Code (the Code) (30 ILCS 500/20-43) provides that a person (other than an individual acting as a sole proprietor) must be a legal entity authorized to do business in the State of Illinois prior to submitting the bid.

10. The services of a subcontractor will be used.

Check box Yes
 Check box No

For known subcontractors with subcontracts with an annual value of more than \$50,000, the contract shall include their name, address, general type of work to be performed, and the dollar allocation for each subcontractor. (30 ILCS 500/20-120)

11. EXECUTION OF CONTRACT. The Department of Transportation will, in accordance with the rules governing Department procurements, execute the contract and shall be the sole entity having the authority to accept performance and make payments under the contract. Execution of the contract by the Chief Procurement Officer (CPO) or the State Purchasing Officer (SPO) is for approval of the procurement process and execution of the contract by the Department. Neither the CPO nor the SPO shall be responsible for administration of the contract or determinations respecting the performance or payment there under except as otherwise permitted in the Code.

STATE JOB #- - - -

ILLINOIS DEPARTMENT OF TRANSPORTATION
 SCHEDULE OF PRICES
 CONTRACT NUMBER - LK010

ECMS002 DTGECM03 ECMR003 PAGE 1
 RUN DATE - 06/28/13
 RUN TIME - 183102

COUNTY NAME	CODE	DIST	AIRPORT NAME	FED PROJECT	ILL PROJECT
MCHENRY	111	01	LAKE IN THE HILLS	- - -	3C-K -4283

ITEM NUMBER	PAY ITEM DESCRIPTION	UNIT OF MEASURE	QUANTITY	UNIT PRICE		TOTAL PRICE	
				DOLLARS	CENTS	DOLLARS	CTS
AR150510	ENGINEER'S FIELD OFFICE	L.S.	1.000 X		=		
AR150520	MOBILIZATION	L.S.	1.000 X		=		
AR152410	UNCLASSIFIED EXCAVATION	C.Y.	250.000 X		=		
AR152442	OFFSITE BORROW EXCAVATION	C.Y.	1,020.000 X		=		
AR156510	SILT FENCE	L.F.	670.000 X		=		
AR156520	INLET PROTECTION	EACH	8.000 X		=		
AR209608	CRUSHED AGG. BASE COURSE - 8"	S.Y.	231.000 X		=		
AR209612	CRUSHED AGG. BASE COURSE - 12"	S.Y.	923.000 X		=		
AR401610	BITUMINOUS SURFACE COURSE	TON	85.000 X		=		
AR403610	BITUMINOUS BASE COURSE	TON	140.000 X		=		
AR501508	8" PCC PAVEMENT	S.Y.	212.000 X		=		
AR602510	BITUMINOUS PRIME COAT	GAL.	300.000 X		=		
AR603510	BITUMINOUS TACK COAT	GAL.	140.000 X		=		
AR620520	PAVEMENT MARKING-WATERBORNE	S.F.	530.000 X		=		
AR701512	12" RCP, CLASS IV	L.F.	185.000 X		=		

LAKE IN THE HILLS
MCHENRY

ILLINOIS DEPARTMENT OF TRANSPORTATION
SCHEDULE OF PRICES
CONTRACT NUMBER - LK010

ECMS002 DTGECM03 ECMR003 PAGE 2
RUN DATE - 06/28/13
RUN TIME - 183102

ITEM NUMBER	PAY ITEM DESCRIPTION	UNIT OF MEASURE	QUANTITY	UNIT PRICE		TOTAL PRICE	
				DOLLARS	CENTS	DOLLARS	CTS
AR705900	REMOVE UNDERDRAIN	L.F.	50.000 X		=		
AR705902	REMOVE UNDERDRAIN END SECTION	EACH	1.000 X		=		
AR751411	INLET-TYPE A	EACH	1.000 X		=		
AR751540	MANHOLE 4'	EACH	2.000 X		=		
AR751550	MANHOLE 5'	EACH	1.000 X		=		
AR752412	PRECAST REINFORCED CONC. FES 12"	EACH	1.000 X		=		
AR800012	REMOVE FUEL FARM	L.S.	1.000 X		=		
AR800013	FUEL STORAGE TANK (100LL)	EACH	1.000 X		=		
AR800014	FUEL STORAGE TANK (JET A)	EACH	1.000 X		=		
AR800040	CREDIT CARD READER	EACH	1.000 X		=		
AR800041	OIL/WATER SEPARATOR	EACH	1.000 X		=		
AR800042	PLUG VALVE	EACH	2.000 X		=		
AR800129	CONTAMINATED SOIL REMOVAL	C.Y.	50.000 X		=		
AR800169	FUEL FARM ELECTRIC SERVICE	L.S.	1.000 X		=		
AR800194	REMOVE ELEVATED RETROREFLECTIVE M	EACH	4.000 X		=		

LAKE IN THE HILLS
MCHENRY

ILLINOIS DEPARTMENT OF TRANSPORTATION
SCHEDULE OF PRICES
CONTRACT NUMBER - LK010

ECMS002 DTGECM03 ECMR003 PAGE 3
RUN DATE - 06/28/13
RUN TIME - 183102

ITEM NUMBER	PAY ITEM DESCRIPTION	UNIT OF MEASURE	QUANTITY	UNIT PRICE		TOTAL PRICE	
				DOLLARS	CENTS	DOLLARS	CTS
AR901510	SEEDING	ACRE	0.600 X			=	
AR908510	MULCHING	ACRE	0.600 X			=	
AR910110	RDWY LIGHT POLE W/FIXTURE	EACH	1.000 X			=	
AR910420	BOLLARD	EACH	20.000 X			=	
TOTAL						\$	

NOTE:

1. EACH PAY ITEM SHOULD HAVE A UNIT PRICE AND A TOTAL PRICE.
2. THE UNIT PRICE SHALL GOVERN IF NO TOTAL PRICE IS SHOWN OR IF THERE IS A DISCREPANCY BETWEEN THE PRODUCT OF THE UNIT PRICE MULTIPLIED BY THE QUANTITY.
3. IF A UNIT PRICE IS OMITTED, THE TOTAL PRICE WILL BE DIVIDED BY THE QUANTITY IN ORDER TO ESTABLISH A UNIT PRICE.
4. A BID MAY BE DECLARED UNACCEPTABLE IF NEITHER A UNIT PRICE NOR A TOTAL PRICE IS SHOWN.

RETURN WITH BID

STATE REQUIRED ETHICAL STANDARDS GOVERNING CONTRACT PROCUREMENT: ASSURANCES, CERTIFICATIONS AND DISCLOSURES

I. GENERAL

A. Article 50 of the Code establishes the duty of all State CPOs, SPOs, and their designees to maximize the value of the expenditure of public moneys in procuring goods, services, and contracts for the State of Illinois and to act in a manner that maintains the integrity and public trust of State government. In discharging this duty, they are charged by law to use all available information, reasonable efforts, and reasonable actions to protect, safeguard, and maintain the procurement process of the State of Illinois.

B. In order to comply with the provisions of Article 50 and to carry out the duty established therein, all bidders are to adhere to ethical standards established for the procurement process, and to make such assurances, disclosures and certifications required by law. Except as otherwise required in subsection III, paragraphs J-M, by execution of the Proposal Signature Sheet, the bidder indicates that each of the mandated assurances has been read and understood, that each certification is made and understood, and that each disclosure requirement has been understood and completed.

C. In addition to all other remedies provided by law, failure to comply with any assurance, failure to make any disclosure or the making of a false certification shall be grounds for the CPO to void the contract, and may result in the suspension or debarment of the bidder or subcontractor. If a false certification is made by a subcontractor, the contractor's submitted bid and the executed contract may not be declared void unless the contractor refuses to terminate the subcontract upon the States' request after a finding that the subcontractor's certification was false.

II. ASSURANCES

The assurances hereinafter made by the bidder are each a material representation of fact upon which reliance is placed should the Department enter into the contract with the bidder.

A. Conflicts of Interest

1. The Code provides in pertinent part:

Section 50-13. Conflicts of Interest.

(a) Prohibition. It is unlawful for any person holding an elective office in this State, holding a seat in the General Assembly, or appointed to or employed in any of the offices or agencies of state government and who receives compensation for such employment in excess of 60% of the salary of the Governor of the State of Illinois, or who is an officer or employee of the Capital Development Board or the Illinois Toll Highway Authority, or who is the spouse or minor child of any such person to have or acquire any contract, or any direct pecuniary interest in any contract therein, whether for stationery, printing, paper, or any services, materials, or supplies, that will be wholly or partially satisfied by the payment of funds appropriated by the General Assembly of the State of Illinois or in any contract of the Capital Development Board or the Illinois Toll Highway Authority.

(b) Interests. It is unlawful for any firm, partnership, association or corporation, in which any person listed in subsection (a) is entitled to receive (i) more than 7 1/2% of the total distributable income or (ii) an amount in excess of the salary of the Governor, to have or acquire any such contract or direct pecuniary interest therein.

(c) Combined interests. It is unlawful for any firm, partnership, association, or corporation, in which any person listed in subsection (a) together with his or her spouse or minor children is entitled to receive (i) more than 15%, in the aggregate, of the total distributable income or (ii) an amount in excess of 2 times the salary of the Governor, to have or acquire any such contract or direct pecuniary interest therein.

(d) Securities. Nothing in this Section invalidates the provisions of any bond or other security previously offered or to be offered for sale or sold by or for the State of Illinois.

(e) Prior interests. This Section does not affect the validity of any contract made between the State and an officer or employee of the State or member of the General Assembly, his or her spouse, minor child or any combination of those persons if that contract was in existence before his or her election or employment as an officer, member, or employee. The contract is voidable, however, if it cannot be completed within 365 days after the officer, member, or employee takes office or is employed.

The current salary of the Governor is \$177,412.00. Sixty percent of the salary is \$106,447.20.

RETURN WITH BID

2. The bidder assures the Department that the award and execution of the contract would not cause a violation of Section 50-13, or that an effective exemption has been issued by the Board of Ethics to any individual subject to the Section 50-13 prohibitions pursuant to the provisions of Section 50-20 of the Code and Executive Order Number 3 (1998). Information concerning the exemption process is available from the Department upon request.

B. Negotiations

1. The Code provides in pertinent part:

Section 50-15. Negotiations.

(a) It is unlawful for any person employed in or on a continual contractual relationship with any of the offices or agencies of State government to participate in contract negotiations on behalf of that office or agency with any firm, partnership, association, or corporation with whom that person has a contract for future employment or is negotiating concerning possible future employment.

2. The bidder assures the Department that the award and execution of the contract would not cause a violation of Section 50-15, and that the bidder has no knowledge of any facts relevant to the kinds of acts prohibited therein.

C. Inducements

1. The Code provides:

Section 50-25. Inducement. Any person who offers or pays any money or other valuable thing to any person to induce him or her not to bid for a State contract or as recompense for not having bid on a State contract is guilty of a Class 4 felony. Any person who accepts any money or other valuable thing for not bidding for a State contract or who withholds a bid in consideration of the promise for the payment of money or other valuable thing is guilty of a Class 4 felony.

2. The bidder assures the Department that the award and execution of the contract would not cause a violation of Section 50-25, and that the bidder has no knowledge of any facts relevant to the kinds of acts prohibited therein.

D. Revolving Door Prohibition

1. The Code provides:

Section 50-30. Revolving door prohibition. CPOs, SPOs, procurement compliance monitors, their designees whose principal duties are directly related to State procurement, and executive officers confirmed by the Senate are expressly prohibited for a period of 2 years after terminating an affected position from engaging in any procurement activity relating to the State agency most recently employing them in an affected position for a period of at least 6 months. The prohibition includes, but is not limited to: lobbying the procurement process; specifying; bidding; proposing bid, proposal, or contract documents; on their own behalf or on behalf of any firm, partnership, association, or corporation. This Section applies only to persons who terminate an affected position on or after January 15, 1999.

2. The bidder assures the Department that the award and execution of the contract would not cause a violation of Section 50-30, and that the bidder has no knowledge of any facts relevant to the kinds of acts prohibited therein.

E. Reporting Anticompetitive Practices

1. The Code provides:

Section 50-40. Reporting anticompetitive practices. When, for any reason, any vendor, bidder, contractor, CPO, SPO, designee, elected official, or State employee suspects collusion or other anticompetitive practice among any bidders, offers, contractors, proposers, or employees of the State, a notice of the relevant facts shall be transmitted to the Attorney General and the CPO.

2. The bidder assures the Department that it has not failed to report any relevant facts concerning the practices addressed in Section 50-40 which may involve the contract for which the bid is submitted.

F. Confidentiality

1. The Code provides:

Section 50-45. Confidentiality. Any CPO, SPO, designee, or executive officer who willfully uses or allows the use of specifications, competitive bid documents, proprietary competitive information, proposals, contracts, or selection information to compromise the fairness or integrity of the procurement, bidding, or contract process shall be subject to immediate dismissal, regardless of the Personnel code, any contract, or any collective bargaining agreement, and may in addition be subject to criminal prosecution.

2. The bidder assures the Department that it has no knowledge of any fact relevant to the practices addressed in Section 50-45 which may involve the contract for which the bid is submitted.

RETURN WITH BID

G. Insider Information

1. The Code provides:

Section 50-50. Insider information. It is unlawful for any current or former elected or appointed State official or State employee to knowingly use confidential information available only by virtue of that office or employment for actual or anticipated gain for themselves or another person.

2. The bidder assures the Department that it has no knowledge of any facts relevant to the practices addressed in Section 50-50 which may involve the contract for which the bid is submitted.

III. CERTIFICATIONS

The certifications hereinafter made by the bidder are each a material representation of fact upon which reliance is placed should the Department enter into the contract with the bidder. Section 50-2 of the Code provides that every person that has entered into a multi-year contract and every subcontractor with a multi-year subcontract shall certify, by July 1 of each fiscal year covered by the contract after the initial fiscal year, to the responsible CPO whether it continues to satisfy the requirements of Article 50 pertaining to the eligibility for a contract award. If a contractor or subcontractor is not able to truthfully certify that it continues to meet all requirements, it shall provide with its certification a detailed explanation of the circumstances leading to the change in certification status. A contractor or subcontractor that makes a false statement material to any given certification required under Article 50 is, in addition to any other penalties or consequences prescribed by law, subject to liability under the Whistleblower Reward and Protection Act for submission of a false claim.

A. Bribery

1. The Code provides:

Section 50-5. Bribery.

(a) Prohibition. No person or business shall be awarded a contract or subcontract under this Code who:

(1) has been convicted under the laws of Illinois or any other state of bribery or attempting to bribe an officer or employee of the State of Illinois or any other state in that officer's or employee's official capacity; or

(2) has made an admission of guilt of that conduct that is a matter of record but has not been prosecuted for that conduct.

(b) Businesses. No business shall be barred from contracting with any unit of State or local government, or subcontracting under such a contract, as a result of a conviction under this Section of any employee or agent of the business if the employee or agent is no longer employed by the business and:

(1) the business has been finally adjudicated not guilty; or

(2) the business demonstrates to the governmental entity with which it seeks to contract, or which is signatory to the contract which the subcontract relates, and that entity finds that the commission of the offense was not authorized, requested, commanded, or performed by a director, officer, or high managerial agent on behalf of the business as provided in paragraph (2) of subsection (a) of Section 5-4 of the Criminal Code of 1961.

(c) Conduct on behalf of business. For purposes of this Section, when an official, agent, or employee of a business committed the bribery or attempted bribery on behalf of the business and in accordance with the direction or authorization of a responsible official of the business, the business shall be chargeable with the conduct.

(d) Certification. Every bid submitted to and contract executed by the State, and every subcontract subject to Section 20-120 of the Code shall contain a certification by the contractor or the subcontractor, respectively, that the contractor or subcontractor is not barred from being awarded a contract or subcontract under this Section and acknowledges that the CPO may declare the related contract void if any certifications required by this Section are false. A contractor who makes a false statement, material to the certification, commits a Class 3 felony.

2. The contractor or subcontractor certifies that it is not barred from being awarded a contract under Section 50.5.

B. Felons

1. The Code provides:

Section 50-10. Felons. Unless otherwise provided, no person or business convicted of a felony shall do business with the State of Illinois or any State agency, or enter into a subcontract, from the date of conviction until 5 years after the date of completion of the sentence for that felony, unless no person held responsible by a prosecutorial office for the facts upon which the conviction was based continues to have any involvement with the business.

2. Certification. Every bid submitted to and contract executed by the State and every subcontract subject to Section 20-120 of the Code shall contain a certification by the bidder or contractor or subcontractor, respectively, that the bidder, contractor, or subcontractor is not barred from being awarded a contract or subcontract under this Section and acknowledges that the CPO may declare the related contract void if any of the certifications required by this Section are false.

RETURN WITH BID

C. Debt Delinquency

1. The Code provides:

Section 50-11 and 50-12. Debt Delinquency.

The contractor or bidder or subcontractor, respectively, certifies that it, or any affiliate, is not barred from being awarded a contract or subcontract under the Code. Section 50-11 prohibits a person from entering into a contract with a State agency, or entering into a subcontract, if it knows or should know that it, or any affiliate, is delinquent in the payment of any debt to the State as defined by the Debt Collection Board. Section 50-12 prohibits a person from entering into a contract with a State agency, or entering into a subcontract, if it, or any affiliate, has failed to collect and remit Illinois Use Tax on all sales of tangible personal property into the State of Illinois in accordance with the provisions of the Illinois Use Tax Act. The bidder or contractor or subcontractor, respectively, further acknowledges that the CPO may declare the related contract void if this certification is false or if the bidder, contractor, or subcontractor, or any affiliate, is determined to be delinquent in the payment of any debt to the State during the term of the contract.

D. Prohibited Bidders, Contractors and Subcontractors

1. The Code provides:

Section 50-10.5 and 50-60(c). Prohibited bidders, contractors and subcontractors.

The bidder or contractor or subcontractor, respectively, certifies in accordance with 30 ILCS 500/50-10.5 that no officer, director, partner or other managerial agent of the contracting business has been convicted of a felony under the Sarbanes-Oxley Act of 2002 or a Class 3 or Class 2 felony under the Illinois Securities Law of 1953 or if in violation of Subsection (c) for a period of five years from the date of conviction. Every bid submitted to and contract executed by the State and every subcontract subject to Section 20-120 of the Code shall contain a certification by the bidder, contractor, or subcontractor, respectively, that the bidder, contractor, or subcontractor is not barred from being awarded a contract or subcontract under this Section and acknowledges that the CPO shall declare the related contract void if any of the certifications completed pursuant to this Section are false.

E. Section 42 of the Environmental Protection Act

The bidder or contractor or subcontractor, respectively, certifies in accordance with 30 ILCS 500/50-14 that the bidder, contractor, or subcontractor, is not barred from being awarded a contract or entering into a subcontract under this Section which prohibits the bidding on or entering into contracts with the State of Illinois or a State agency, or entering into any subcontract, that is subject to the Code by a person or business found by a court or the Pollution Control Board to have committed a willful or knowing violation of Section 42 of the Environmental Protection Act for a period of five years from the date of the order. The bidder or contractor or subcontractor, respectively, acknowledges that the CPO may declare the contract void if this certification is false.

F. Educational Loan

1. Section 3 of the Educational Loan Default Act provides:

§ 3. No State agency shall contract with an individual for goods or services if that individual is in default, as defined in Section 2 of this Act, on an educational loan. Any contract used by any State agency shall include a statement certifying that the individual is not in default on an educational loan as provided in this Section.

2. The bidder, if an individual as opposed to a corporation, partnership or other form of business organization, certifies that the bidder is not in default on an educational loan as provided in Section 3 of the Act.

G. Bid-Rigging/Bid Rotating

1. Section 33E-11 of the Criminal Code of 1961 provides:

§ 33E-11. (a) Every bid submitted to and public contract executed pursuant to such bid by the State or a unit of local government shall contain a certification by the prime contractor that the prime contractor is not barred from contracting with any unit of State or local government as a result of a violation of either Section 33E-3 or 33E-4 of this Article. The State and units of local government shall provide the appropriate forms for such certification.

- (b) A contractor who makes a false statement, material to the certification, commits a Class 3 felony.

A violation of Section 33E-3 would be represented by a conviction of the crime of bid-rigging which, in addition to Class 3 felony sentencing, provides that any person convicted of this offense or any similar offense of any state or the United States which contains the same elements as this offense shall be barred for 5 years from the date of conviction from contracting with any unit of State or local government. No corporation shall be barred from contracting with any unit of State or local government as a result of a conviction under this Section of any employee or agent of such corporation if the employee so convicted is no longer employed by the corporation and: (1) it has been finally adjudicated not guilty or (2) if it demonstrates to the governmental entity with which it seeks to contract and that entity finds that the commission of the offense was neither authorized, requested, commanded, nor performed by a director, officer or a high managerial agent in behalf of the corporation.

RETURN WITH BID

A violation of Section 33E-4 would be represented by a conviction of the crime of bid-rotating which, in addition to Class 2 felony sentencing, provides that any person convicted of this offense or any similar offense of any state or the United States which contains the same elements as this offense shall be permanently barred from contracting with any unit of State or local government. No corporation shall be barred from contracting with any unit of State or local government as a result of a conviction under this Section of any employee or agent of such corporation if the employee so convicted is no longer employed by the corporation and: (1) it has been finally adjudicated not guilty or (2) if it demonstrates to the governmental entity with which it seeks to contract and that entity finds that the commission of the offense was neither authorized, requested, commanded, nor performed by a director, officer or a high managerial agent in behalf of the corporation.

2. The bidder certifies that it is not barred from contracting with the Department by reason of a violation of either Section 33E-3 or Section 33E-4.

H. International Anti-Boycott

1. Section 5 of the International Anti-Boycott Certification Act provides:

§ 5. State contracts. Every contract entered into by the State of Illinois for the manufacture, furnishing, or purchasing of supplies, material, or equipment or for the furnishing of work, labor, or services, in an amount exceeding the threshold for small purchases according to the purchasing laws of this State or \$10,000.00, whichever is less, shall contain certification, as a material condition of the contract, by which the contractor agrees that neither the contractor nor any substantially-owned affiliated company is participating or shall participate in an international boycott in violation of the provisions of the U.S. Export Administration Act of 1979 or the regulations of the U.S. Department of Commerce promulgated under that Act.

2. The bidder makes the certification set forth in Section 5 of the Act.

I. Drug Free Workplace

1. The Illinois "Drug Free Workplace Act" applies to this contract and it is necessary to comply with the provisions of the "Act" if the contractor is a corporation, partnership, or other entity (including a sole proprietorship) which has 25 or more employees.

2. The bidder certifies that if awarded a contract in excess of \$5,000 it will provide a drug free workplace by:

(a) Publishing a statement notifying employees that the unlawful manufacture, distribution, dispensation, possession or use of a controlled substance, including cannabis, is prohibited in the contractor's workplace; specifying the actions that will be taken against employees for violations of such prohibition; and notifying the employee that, as a condition of employment on such contract, the employee shall abide by the terms of the statement, and notify the employer of any criminal drug statute conviction for a violation occurring in the workplace no later than five (5) days after such conviction.

(b) Establishing a drug free awareness program to inform employees about the dangers of drug abuse in the workplace; the contractor's policy of maintaining a drug free workplace; any available drug counseling, rehabilitation, and employee assistance programs; and the penalties that may be imposed upon employees for drug violations.

(c) Providing a copy of the statement required by subparagraph (1) to each employee engaged in the performance of the contract and to post the statement in a prominent place in the workplace.

(d) Notifying the Department within ten (10) days after receiving notice from an employee or otherwise receiving actual notice of the conviction of an employee for a violation of any criminal drug statute occurring in the workplace.

(e) Imposing or requiring, within 30 days after receiving notice from an employee of a conviction or actual notice of such a conviction, an appropriate personnel action, up to and including termination, or the satisfactory participation in a drug abuse assistance or rehabilitation program approved by a federal, state or local health, law enforcement or other appropriate agency.

(f) Assisting employees in selecting a course of action in the event drug counseling, treatment, and rehabilitation is required and indicating that a trained referral team is in place.

(g) Making a good faith effort to continue to maintain a drug free workplace through implementation of the actions and efforts stated in this certification.

RETURN WITH BID

J. Disclosure of Business Operations in Iran

Section 50-36 of the Code, 30ILCS 500/50-36 provides that each bid, offer, or proposal submitted for a State contract shall include a disclosure of whether or not the Company acting as the bidder, offeror, or proposing entity, or any of its corporate parents or subsidiaries, within the 24 months before submission of the bid, offer, or proposal had business operations that involved contracts with or provision of supplies or services to the Government of Iran, companies in which the Government of Iran has any direct or indirect equity share, consortiums or projects commissioned by the Government of Iran, or companies involved in consortiums or projects commissioned by the Government of Iran and either of the following conditions apply:

- (1) More than 10% of the Company's revenues produced in or assets located in Iran involve oil-related activities or mineral-extraction activities; less than 75% of the Company's revenues produced in or assets located in Iran involve contracts with or provision of oil-related or mineral-extraction products or services to the Government of Iran or a project or consortium created exclusively by that government; and the Company has failed to take substantial action.
- (2) The Company has, on or after August 5, 1996, made an investment of \$20 million or more, or any combination of investments of at least \$10 million each that in the aggregate equals or exceeds \$20 million in any 12-month period, which directly or significantly contributes to the enhancement of Iran's ability to develop petroleum resources of Iran.

The terms "Business operations", "Company", "Mineral-extraction activities", "Oil-related activities", "Petroleum resources", and "Substantial action" are all defined in the Code.

Failure to make the disclosure required by the Code shall cause the bid, offer or proposal to be considered not responsive. The disclosure will be considered when evaluating the bid, offer, or proposal or awarding the contract. The name of each Company disclosed as doing business or having done business in Iran will be provided to the State Comptroller.

Check the appropriate statement:

Company has no business operations in Iran to disclose.

Company has business operations in Iran as disclosed in the attached document.

K. Apprenticeship and Training Certification (Does not apply to federal aid projects)

In accordance with the provisions of Section 30-22 (6) of the Code, the bidder certifies that it is a participant, either as an individual or as part of a group program, in the approved apprenticeship and training programs applicable to each type of work or craft that the bidder will perform with its own forces. The bidder further certifies for work that will be performed by subcontract that each of its subcontractors submitted for approval either (a) is, at the time of such bid, participating in an approved, applicable apprenticeship and training program; or (b) will, prior to commencement of performance of work pursuant to this contract, begin participation in an approved apprenticeship and training program applicable to the work of the subcontract. The Department, at any time before or after award, may require the production of a copy of each applicable Certificate of Registration issued by the United States Department of Labor evidencing such participation by the contractor and any or all of its subcontractors. Applicable apprenticeship and training programs are those that have been approved and registered with the United States Department of Labor. The bidder shall list in the space below, the official name of the program sponsor holding the Certificate of Registration for all of the types of work or crafts in which the bidder is a participant and that will be performed with the bidder's forces. Types of work or craft work that will be subcontracted shall be included and listed as subcontracted work. The list shall also indicate any type of work or craft job category that does not have an applicable apprenticeship or training program. **The bidder is responsible for making a complete report and shall make certain that each type of work or craft job category that will be utilized on the project as reported on the Construction Employee Workforce Projection (Form BC-1256) and returned with the bid is accounted for and listed.**

NA-FEDERAL

The requirements of this certification and disclosure are a material part of the contract, and the contractor shall require this certification provision to be included in all approved subcontracts. In order to fulfill this requirement, it shall not be necessary that an applicable program sponsor be currently taking or that it will take applications for apprenticeship, training or employment during the performance of the work of this contract.

RETURN WITH BID

L. Political Contributions and Registration with the State Board of Elections.

Sections 20-160 and 50-37 of the Code regulate political contributions from business entities and any affiliated entities or affiliated persons bidding on or contracting with the state. Generally under Section 50-37, any business entity, and any affiliated entity or affiliated person of the business entity, whose current year contracts with all state agencies exceed an awarded value of \$50,000, are prohibited from making any contributions to any political committees established to promote the candidacy of the officeholder responsible for the awarding of the contracts or any other declared candidate for that office for the duration of the term of office of the incumbent officeholder or a period 2 years after the termination of the contract, whichever is longer. Any business entity and affiliated entities or affiliated persons whose state contracts in the current year do not exceed an awarded value of \$50,000, either alone or in combination with contracts not exceeding \$50,000, are prohibited from making any political contributions to any political committee established to promote the candidacy of the officeholder responsible for awarding the pending contract during the period beginning on the date the invitation for bids or request for proposals is issued and ending on the day after the date of award or selection if the entity was not awarded or selected. Section 20-160 requires certification of registration of affected business entities in accordance with procedures found in Section 9-35 of The Election Code

By submission of a bid, the contractor business entity acknowledges and agrees that it has read and understands Sections 20-160 and 50-37 of the Code, and that it makes the following certification:

The undersigned business entity certifies that it has registered as a business with the State Board of Elections and acknowledges a continuing duty to update the registration in accordance with the above referenced statutes. If the business entity is required to register, the CPO shall verify that it is in compliance on the date the bid or proposal is due. The CPO shall not accept a bid or proposal if the business entity is not in compliance with the registration requirements.

These requirements and compliance with the above referenced statutory sections are a material part of the contract, and any breach thereof shall be cause to void the contract under Section 50-60 of the Code. This provision does not apply to Federal-aid contracts.

M. Lobbyist Disclosure

Section 50-38 of the Code requires that any bidder or offeror on a State contract that hires a person required to register under the Lobbyist Registration Act to assist in obtaining a contract shall:

- (i) Disclose all costs, fees, compensation, reimbursements, and other remunerations paid or to be paid to the lobbyist related to the contract,
- (ii) Not bill or otherwise cause the State of Illinois to pay for any of the lobbyist's costs, fees, compensation, reimbursements, or other remuneration, and
- (iii) Sign a verification certifying that none of the lobbyist's costs, fees, compensation, reimbursements, or other remuneration were billed to the State.

This information, along with all supporting documents, shall be filed with the agency awarding the contract and with the Secretary of State. The CPO shall post this information, together with the contract award notice, in the online Procurement Bulletin.

Pursuant to Subsection (c) of this Section, no person or entity shall retain a person or entity to attempt to influence the outcome of a procurement decision made under the Code for compensation contingent in whole or in part upon the decision or procurement. Any person who violates this subsection is guilty of a business offense and shall be fined not more than \$10,000.

Bidder acknowledges that it is required to disclose the hiring of any person required to register pursuant to the Illinois Lobbyist Registration Act (25 ILCS 170) in connection with this contract.

Bidder has not hired any person required to register pursuant to the Illinois Lobbyist Registration Act in connection with this contract.

Or

Bidder has hired the following persons required to register pursuant to the Illinois Lobbyist Registration Act in connection with the contract:

Name and address of person: _____
All costs, fees, compensation, reimbursements and other remuneration paid to said person: _____

RETURN WITH BID

IV. DISCLOSURES

- A. The disclosures hereinafter made by the bidder are each a material representation of fact upon which reliance is placed should the Department enter into the contract with the bidder. The bidder further certifies that the Department has received the disclosure forms for each bid.

The CPO may void the bid, or contract, respectively, if it is later determined that the bidder or subcontractor rendered a false or erroneous disclosure. A contractor or subcontractor may be suspended or debarred for violations of the Code. Furthermore, the CPO may void the contract and the surety providing the performance bond shall be responsible for completion of the contract.

B. Financial Interests and Conflicts of Interest

1. Section 50-35 of the Code provides that all bids of more than \$25,000 shall be accompanied by disclosure of the financial interests of the bidder. This disclosed information for the successful bidder, will be maintained as public information subject to release by request pursuant to the Freedom of Information Act, filed with the Procurement Policy Board, and shall be incorporated as a material term of the contract. Furthermore, pursuant to Section 5-5, the Procurement Policy Board may review a proposal, bid, or contract and issue a recommendation to void a contract or reject a proposal or bid based on any violation of the Code or the existence of a conflict of interest as provided in subsections (b) and (d) of Section 50-35.

The financial interests to be disclosed shall include ownership or distributive income share that is in excess of 5%, or an amount greater than 60% of the annual salary of the Governor, of the bidding entity or its parent entity, whichever is less, unless the contractor or bidder is a publicly traded entity subject to Federal 10K reporting, in which case it may submit its 10K disclosure in place of the prescribed disclosure. If a bidder is a privately held entity that is exempt from Federal 10K reporting, but has more than 200 shareholders, it may submit the information that Federal 10K companies are required to report, and list the names of any person or entity holding any ownership share that is in excess of 5%. The disclosure shall include the names, addresses, and dollar or proportionate share of ownership of each person making the disclosure, their instrument of ownership or beneficial relationship, and notice of any potential conflict of interest resulting from the current ownership or beneficial interest of each person making the disclosure having any of the relationships identified in Section 50-35 and on the disclosure form.

The current annual salary of the Governor is \$177,412.00

In addition, all disclosures shall indicate any other current or pending contracts, proposals, leases, or other ongoing procurement relationships the bidding entity has with any other unit of state government and shall clearly identify the unit and the contract, proposal, lease, or other relationship.

2. Disclosure Forms. Disclosure Form A is attached for use concerning the individuals meeting the above ownership or distributive share requirements. A separate Disclosure Form A must be submitted with the bid for each individual meeting the above requirements. In addition, a second form (Disclosure Form B) provides for the disclosure of current or pending procurement relationships with other (non-IDOT) state agencies and a total ownership certification. **The forms must be included with each bid.**

C. Disclosure Form Instructions

Form A Instructions for Financial Information & Potential Conflicts of Interest

If the bidder is a publicly traded entity subject to Federal 10K reporting, the 10K Report may be submitted to meet the requirements of Form A. If a bidder is a privately held entity that is exempt from Federal 10K reporting, but has more than 400 shareholders, it may submit the information that Federal 10K companies are required to report, and list the names of any person or entity holding any ownership share that is in excess of 5%. If a bidder is not subject to Federal 10K reporting, the bidder must determine if any individuals are required by law to complete a financial disclosure form. To do this, the bidder should answer each of the following questions. A "YES" answer indicates Form A must be completed. If the answer to each of the following questions is "NO", then the NOT APPLICABLE STATEMENT on Form A must be signed and dated by a person that is authorized to execute contracts for the bidding company. Note: These questions are for assistance only and are not required to be completed.

1. Does anyone in your organization have a direct or beneficial ownership share of greater than 5% of the bidding entity or parent entity? YES _____ NO _____
2. Does anyone in your organization have a direct or beneficial ownership share of less than 5%, but which has a value greater than 60% of the annual salary of the Governor? YES _____ NO _____
3. Does anyone in your organization receive more than 60% of the annual salary of the Governor of the bidding entity's or parent entity's distributive income? (Note: Distributive income is, for these purposes, any type of distribution of profits. An annual salary is not distributive income.) YES _____ NO _____
4. Does anyone in your organization receive greater than 5% of the bidding entity's or parent entity's total distributive income, but which is less than 60% of the annual salary of the Governor? YES _____ NO _____

(Note: Only one set of forms needs to be completed per person per bid even if a specific individual would require a yes answer to more than one question.)

A "YES" answer to any of these questions requires the completion of Form A. The bidder must determine each individual in the bidding entity or the bidding entity's parent company that would cause the questions to be answered "Yes". Each form must be signed and dated by a person that is authorized to execute contracts for your organization. **Photocopied or stamped signatures are not acceptable.** The person signing can be, but does not have to be, the person for which the form is being completed. The bidder is responsible for the accuracy of any information provided.

If the answer to each of the above questions is "NO", then the NOT APPLICABLE STATEMENT of Form A must be signed and dated by a person that is authorized to execute contracts for your company.

RETURN WITH BID

Form B: Instructions for Identifying Other Contracts & Procurement Related Information

Disclosure Form B must be completed for each bid submitted by the bidding entity. *Note: Checking the NOT APPLICABLE STATEMENT on Form A does not allow the bidder to ignore Form B. Form B must be completed, checked, and dated or the bidder may be considered nonresponsive and the bid will not be accepted.*

The Bidder shall identify, by checking Yes or No on Form B, whether it has any pending contracts (including leases), bids, proposals, or other ongoing procurement relationship with any other (non-IDOT) State of Illinois agency. If "No" is checked, the bidder only needs to complete the check box on the bottom of Form B. If "Yes" is checked, the bidder must do one of the following:

Option I: If the bidder did not submit an Affidavit of Availability to obtain authorization to bid, the bidder must list all non-IDOT State of Illinois agency pending contracts, leases, bids, proposals, and other ongoing procurement relationships. These items may be listed on Form B or on an attached sheet(s). Do not include IDOT contracts. Contracts with cities, counties, villages, etc. are not considered State of Illinois agency contracts and are not to be included. Contracts with other State of Illinois agencies such as the Department of Natural Resources or the Capital Development Board must be included. Bidders who submit Affidavits of Availability are suggested to use Option II.

Option II: If the bidder is required and has submitted an Affidavit of Availability in order to obtain authorization to bid, the bidder may write or type "See Affidavit of Availability" which indicates that the Affidavit of Availability is incorporated by reference and includes all non-IDOT State of Illinois agency pending contracts, leases, bids, proposals, and other ongoing procurement relationships. For any contracts that are not covered by the Affidavit of Availability, the bidder must identify them on Form B or on an attached sheet(s). These might be such things as leases.

RETURN WITH BID

**ILLINOIS DEPARTMENT
OF TRANSPORTATION**

**Form A
Financial Information &
Potential Conflicts of Interest
Disclosure**

Contractor Name		
Legal Address		
City, State, Zip		
Telephone Number	Email Address	Fax Number (if available)

Disclosure of the information contained in this Form is required by the Section 50-35 of the Code (30 ILCS 500). Vendors desiring to enter into a contract with the State of Illinois must disclose the financial information and potential conflict of interest information as specified in this Disclosure Form. This information shall become part of the publicly available contract file. This Form A must be completed for bids in excess of \$25,000, and for all open-ended contracts. **A publicly traded company may submit a 10K disclosure (or equivalent if applicable) in satisfaction of the requirements set forth in Form A. See Disclosure Form Instructions.**
The current salary of the Governor is \$177,412.00.

DISCLOSURE OF FINANCIAL INFORMATION

1. Disclosure of Financial Information. The individual named below has an interest in the BIDDER (or its parent) in terms of ownership or distributive income share in excess of 5%, or an interest which has a value of more than 60% of the annual salary of the Governor. **(Make copies of this form as necessary and attach a separate Disclosure Form A for each individual meeting these requirements)**

FOR INDIVIDUAL (type or print information)	
NAME:	_____
ADDRESS	_____
Type of ownership/distributable income share:	
stock _____	sole proprietorship _____
partnership _____	other: (explain on separate sheet)
% or \$ value of ownership/distributable income share: _____	

2. Disclosure of Potential Conflicts of Interest. Check "Yes" or "No" to indicate which, if any, of the following potential conflict of interest relationships apply. If the answer to any question is "Yes", please attach additional pages and describe.

(a) State employment, currently or in the previous 3 years, including contractual employment of services. Yes____ No____ If your answer is yes, please answer each of the following questions.

1. Are you currently an officer or employee of either the Capitol Development Board or the Illinois State Toll Highway Authority? Yes____ No____
2. Are you currently appointed to or employed by any agency of the State of Illinois? If you are currently appointed to or employed by any agency of the State of Illinois, and your annual salary exceeds 60% of the annual salary of the Governor, provide the name of the State agency for which you are employed and your annual salary. _____

RETURN WITH BID

- 3. If you are currently appointed to or employed by any agency of the State of Illinois, and your annual salary exceeds 60% of the annual salary of the Governor, are you entitled to receive (i) more than 7 1/2% of the total distributable income of your firm, partnership, association or corporation, or (ii) an amount in excess of 100% of the annual salary of the Governor? Yes _____ No _____
- 4. If you are currently appointed to or employed by any agency of the State of Illinois, and your annual salary exceeds 60% of the annual salary of the Governor, are you and your spouse or minor children entitled to receive (i) more than 15 % in the aggregate of the total distributable income of your firm, partnership, association or corporation, or (ii) an amount in excess of two times the salary of the Governor? Yes _____ No _____

(b) State employment of spouse, father, mother, son, or daughter, including contractual employment for services in the previous 2 years. Yes _____ No _____

If your answer is yes, please answer each of the following questions.

- 1. Is your spouse or any minor children currently an officer or employee of the Capital Development Board or the Illinois State Toll Highway Authority? Yes _____ No _____
- 2. Is your spouse or any minor children currently appointed to or employed by any agency of the State of Illinois? If your spouse or minor children is/are currently appointed to or employed by any agency of the State of Illinois, and his/her annual salary exceeds 60% of the annual salary of the Governor, provide the name of your spouse and/or minor children, the name of the State agency for which he/she is employed and his/her annual salary. _____

- 3. If your spouse or any minor children is/are currently appointed to or employed by any agency of the State of Illinois, and his/her annual salary exceeds 60% of the annual salary of the Governor, are you entitled to receive (i) more than 7 1/2% of the total distributable income of your firm, partnership, association or corporation, or (ii) an amount in excess of 100% of the annual salary of the Governor? Yes _____ No _____
- 4. If your spouse or any minor children are currently appointed to or employed by any agency of the State of Illinois, and his/her annual salary exceeds 60% of the annual salary of the Governor, are you and your spouse or minor children entitled to receive (i) more than 15% in the aggregate of the total distributable income of your firm, partnership, association or corporation, or (ii) an amount in excess of two times the salary of the Governor? Yes _____ No _____

(c) Elective status; the holding of elective office of the State of Illinois, the government of the United States, any unit of local government authorized by the Constitution of the State of Illinois or the statutes of the State of Illinois currently or in the previous 3 years. Yes _____ No _____

(d) Relationship to anyone holding elective office currently or in the previous 2 years; spouse, father, mother, son, or daughter Yes _____ No _____

(e) Appointive office; the holding of any appointive government office of the State of Illinois, the United States of America, or any unit of local government authorized by the Constitution of the State of Illinois or the statutes of the State of Illinois, which office entitles the holder to compensation in excess of the expenses incurred in the discharge of that office currently or in the previous 3 years. Yes _____ No _____

(f) Relationship to anyone holding appointive office currently or in the previous 2 years; spouse, father, mother, son, or daughter. Yes _____ No _____

(g) Employment, currently or in the previous 3 years, as or by any registered lobbyist of the State government. Yes _____ No _____

RETURN WITH BID

(h) Relationship to anyone who is or was a registered lobbyist in the previous 2 years; spouse, father, mother, son, or daughter. Yes____ No____

(i) Compensated employment, currently or in the previous 3 years, by any registered election or reelection committee registered with the Secretary of State or any county clerk of the State of Illinois, or any political action committee registered with either the Secretary of State or the Federal Board of Elections
Yes____ No____

(j) Relationship to anyone; spouse, father, mother, son, or daughter; who was a compensated employee in the last 2 years by any registered election or re-election committee registered with the Secretary of State or any county clerk of the State of Illinois, or any political action committee registered with either the Secretary of State or the Federal Board of Elections.
Yes____ No____

3. Communication Disclosure.

Disclose the name and address of each lobbyist and other agent of the bidder or offeror who is not identified in Section 2 of this form, who has communicated, is communicating, or may communicate with any State officer or employee concerning the bid or offer. This disclosure is a continuing obligation and must be promptly supplemented for accuracy throughout the process and throughout the term of the contract. If no person is identified, enter "None" on the line below:

Name and address of person(s): _____

RETURN WITH BID

4. Debarment Disclosure. For each of the persons identified under Sections 2 and 3 of this form, disclose whether any of the following has occurred within the previous 10 years: debarment from contracting with any governmental entity; professional licensure discipline; bankruptcies; adverse civil judgments and administrative findings; and criminal felony convictions. This disclosure is a continuing obligation and must be promptly supplemented for accuracy throughout the procurement process and term of the contract. If no person is identified, enter "None" on the line below:

Name of person(s): _____

Nature of disclosure: _____

APPLICABLE STATEMENT

This Disclosure Form A is submitted on behalf of the INDIVIDUAL named on previous page. Under penalty of perjury, I certify the contents of this disclosure to be true and accurate to the best of my knowledge.

Completed by:

Signature of Individual or Authorized Officer

Date

NOT APPLICABLE STATEMENT

Under penalty of perjury, I have determined that no individuals associated with this organization meet the criteria that would require the completion of this Form A.

This Disclosure Form A is submitted on behalf of the CONTRACTOR listed on the previous page.

Signature of Authorized Officer

Date

The bidder has a continuing obligation to supplement these disclosures under Sec. 50-35 of the Code.

RETURN WITH BID

ILLINOIS DEPARTMENT OF TRANSPORTATION

Form B Other Contracts & Procurement Related Information Disclosure

Contractor Name, Legal Address, City, State, Zip, Telephone Number, Email Address, Fax Number (if available)

Disclosure of the information contained in this Form is required by the Section 50-35 of the Code (30 ILCS 500). This information shall become part of the publicly available contract file. This Form B must be completed for bids in excess of \$25,000, and for all open-ended contracts.

DISCLOSURE OF OTHER CONTRACTS AND PROCUREMENT RELATED INFORMATION

1. Identifying Other Contracts & Procurement Related Information. The BIDDER shall identify whether it has any pending contracts (including leases), bids, proposals, or other ongoing procurement relationship with any other State of Illinois agency: Yes _____ No _____ If "No" is checked, the bidder only needs to complete the signature box on the bottom of this page.

2. If "Yes" is checked. Identify each such relationship by showing State of Illinois agency name and other descriptive information such as bid or project number (attach additional pages as necessary). SEE DISCLOSURE FORM INSTRUCTIONS:

THE FOLLOWING STATEMENT MUST BE CHECKED

Signature of Authorized Representative, Date

OWNERSHIP CERTIFICATION

Please certify that the following statement is true if the individuals for all submitted Form A disclosures do not total 100% of ownership.

Any remaining ownership interest is held by individuals receiving less than \$106,447.20 of the bidding entity's or parent entity's distributive income or holding less than a 5% ownership interest.

Yes No N/A (Form A disclosure(s) established 100% ownership)

RETURN WITH BID

SPECIAL NOTICE TO CONTRACTORS

The following requirements of the Illinois Department of Human Rights' Rules and Regulations are applicable to bidders on all construction contracts advertised by the Illinois Department of Transportation:

CONSTRUCTION EMPLOYEE UTILIZATION PROJECTION

- (a) All bidders on construction contracts shall complete and submit, along with and as part of their bids, a Bidder's Employee Utilization Form (Form BC-1256) setting forth a projection and breakdown of the total workforce intended to be hired and/or allocated to such contract work by the bidder including a projection of minority and female employee utilization in all job classifications on the contract project.
- (b) The Department of Transportation shall review the Employee Utilization Form, and workforce projections contained therein, of the contract awardee to determine if such projections reflect an underutilization of minority persons and/or women in any job classification in accordance with the Equal Employment Opportunity Clause and Section 7.2 of the Illinois Department of Human Rights' Rules and Regulations for Public Contracts adopted as amended on September 17, 1980. If it is determined that the contract awardee's projections reflect an underutilization of minority persons and/or women in any job classification, it shall be advised in writing of the manner in which it is underutilizing and such awardee shall be considered to be in breach of the contract unless, prior to commencement of work on the contract project, it submits revised satisfactory projections or an acceptable written affirmative action plan to correct such underutilization including a specific timetable geared to the completion stages of the contract.
- (c) The Department of Transportation shall provide to the Department of Human Rights a copy of the contract awardee's Employee Utilization Form, a copy of any required written affirmative action plan, and any written correspondence related thereto. The Department of Human Rights may review and revise any action taken by the Department of Transportation with respect to these requirements.

RETURN WITH BID

**Contract No. LK010
Lake in the Hills Airport
Lake in the Hills, Illinois
McHenry County
Illinois Project No. 3CK-4283
SBG Project No. TBD**

PART II. WORKFORCE PROJECTION - continued

- B. Included in "Total Employees" under Table A is the total number of **new hires** that would be employed in the event the undersigned bidder is awarded this contract.

The undersigned bidder projects that: (number) _____ new hires would be recruited from the area in which the contract project is located; and/or (number) _____ new hires would be recruited from the area in which the bidder's principal office or base of operation is located.

- C. Included in "Total Employees" under Table A is a projection of numbers of persons to be employed directly by the undersigned bidder as well as a projection of numbers of persons to be employed by subcontractors.

The undersigned bidder estimates that (number) _____ persons will be directly employed by the prime contractor and that (number) _____ persons will be employed by subcontractors.

PART III. AFFIRMATIVE ACTION PLAN

- A. The undersigned bidder understands and agrees that in the event the foregoing minority and female employee utilization projection included under **PART II** is determined to be an underutilization of minority persons or women in any job category, and in the event that the undersigned bidder is awarded this contract, he/she will, prior to commencement of work, develop and submit a written Affirmative Action Plan including a specific timetable (geared to the completion stages of the contract) whereby deficiencies in minority and/or female employee utilization are corrected. Such Affirmative Action Plan will be subject to approval by the contracting agency and the **Department of Human Rights**.
- B. The undersigned bidder understands and agrees that the minority and female employee utilization projection submitted herein, and the goals and timetable included under an Affirmative Action Plan if required, are deemed to be part of the contract specifications.

Company _____

Telephone Number _____

Address _____

NOTICE REGARDING SIGNATURE

The Bidder's signature on the Proposal Signature Sheet will constitute the signing of this form. The following signature block needs to be completed only if revisions are required.

Signature: _____ Title: _____ Date: _____

Instructions: All tables must include subcontractor personnel in addition to prime contractor personnel.

Table A - Include both the number of employees that would be hired to perform the contract work and the total number currently employed (Table B) that will be allocated to contract work, and include all apprentices and on-the-job trainees. The "Total Employees" column should include all employees including all minorities, apprentices and on-the-job trainees to be employed on the contract work.

Table B - Include all employees currently employed that will be allocated to the contract work including any apprentices and on-the-job trainees currently employed.

Table C - Indicate the racial breakdown of the total apprentices and on-the-job trainees shown in Table A.

RETURN WITH BID

ADDITIONAL FEDERAL REQUIREMENTS

In addition to the Required Contract Provisions for Federally funded airport construction contracts, all bidders make the following certifications.

A. By the execution of this proposal, the signing bidder certifies that the bidding entity has not, either directly or indirectly, entered into any agreement, participated in any collusion, or otherwise taken any action, in restraint of free competitive bidding in connection with the submitted bid. This statement made by the undersigned bidder is true and correct under penalty of perjury under the laws of the United States.

B. CERTIFICATION, EQUAL EMPLOYMENT OPPORTUNITY

1. Have you participated in any previous contracts or subcontracts subject to the equal opportunity clause?
Yes____ No____

2. If your answer is yes, have you filed with the Joint Reporting Committee, the Director of OFCC, any Federal agency, or the former President's Committee on Equal Employment Opportunity, all reports due under the applicable filing requirements of those organizations? Yes____ No____

RETURN WITH BID

**Contract No. LK010
Lake in the Hills Airport
Lake in the Hills, Illinois
McHenry County
Illinois Project No. 3CK-4283
SBG Project No. TBD**

PROPOSAL SIGNATURE SHEET

The undersigned bidder hereby makes and submits this bid on the subject Proposal, thereby assuring the Department that all requirements of the Invitation for Bids and rules of the Department have been met, that there is no misunderstanding of the requirements of paragraph 4 of this Proposal, and that the contract will be executed in accordance with the rules of the Department if an award is made on this bid.

Firm Name _____

(IF AN INDIVIDUAL) Signature of Owner _____

Business Address _____

Firm Name _____

By _____

(IF A CO-PARTNERSHIP) Business Address _____

Name and Address of All Members of the Firm:

Corporate Name _____

By _____

(IF A CORPORATION) Signature of Authorized Representative _____

Typed or printed name and title of Authorized Representative _____

(IF A JOINT VENTURE, USE THIS SECTION FOR THE MANAGING PARTY AND THE SECOND PARTY SHOULD SIGN BELOW) Attest _____

Signature _____

Business Address _____

Corporate Name _____

By _____

(IF A JOINT VENTURE) Signature of Authorized Representative _____

Typed or printed name and title of Authorized Representative _____

Attest _____

Signature _____

Business Address _____

If more than two parties are in the joint venture, please attach additional signature sheet



Sponsor _____ Item No. _____

IL Proj. No. _____ SBG Pr. No. _____ Letting Date _____

KNOW ALL MEN BY THESE PRESENTS, That We _____

_____ as PRINCIPAL, and _____

_____ as SURETY, are held jointly, severally and firmly bound unto the SPONSOR identified above, in the penal sum of 5 percent of the total bid price, or for the amount specified in Section 6, Proposal Guaranty of the Proposal Document, whichever is the lesser sum, well and truly to be paid unto said SPONSOR, for the payment of which we bind ourselves, our heirs, executors, administrators, successors and assigns.

THE CONDITION OF THE FOREGOING OBLIGATION IS SUCH, that whereas, the PRINCIPAL has submitted a bid proposal to the SPONSOR through its AGENT, the State of Illinois, Department of Transportation, Division of Aeronautics, for the improvement designated by the Transportation Bulletin Item Number and Letting Date indicated above.

NOW, THEREFORE, if the SPONSOR through its AGENT shall accept the bid proposal of the PRINCIPAL; and if the PRINCIPAL shall, and as specified in the bidding and contract documents, submit a DBE Utilization Plan that is accepted and approved by the AGENT; and if, after the award by AGENT on behalf of SPONSOR, the PRINCIPAL shall enter into a contract in accordance with the terms of the bidding and contract documents, including evidence of the required insurance coverages and providing such bond as specified with good and sufficient surety for the faithful performance of such contract and for the prompt payment of labor and material furnished in the prosecution thereof; or if, in the event of the failure of the PRINCIPAL to make the required DBE submission or to enter into such contract and to give the specified bond, the PRINCIPAL pays to the SPONSOR the difference not to exceed the penalty hereof between the amount specified in the bid proposal and such larger amount for which the SPONSOR may contract with another party to perform the work covered by said bid proposal, then this obligation shall be null and void, otherwise, it shall remain in full force and effect.

IN THE EVENT the SPONSOR acting through its AGENT determines the PRINCIPAL has failed to comply with any requirement as set forth in the preceding paragraph, then SURETY shall pay the penal sum to the SPONSOR within fifteen (15) days of written demand therefor. If SURETY does not make full payment within such period of time, the AGENT may bring an action to collect the amount owed. SURETY is liable to the SPONSOR and to the AGENT for all its expenses, including attorney's fees, incurred in any litigation in which SPONSOR or AGENT prevail either in whole or in part.

In TESTIMONY WHEREOF, the said PRINCIPAL and the said SURETY have caused this instrument to be signed by their respective officers _____ day of _____ A.D., _____ .

PRINCIPAL

SURETY

(Company Name)

(Company Name)

By _____
(Signature & Title)

By: _____
(Signature of Attorney-in-Fact)

Notary Certification for Principal and Surety

STATE OF ILLINOIS,
County of _____

I, _____, a Notary Public in and for said County, do hereby certify that _____ and _____
(Insert names of individuals signing on behalf of PRINCIPAL & SURETY)

who are each personally known to me to be the same persons whose names are subscribed to the foregoing instrument on behalf of PRINCIPAL and SURETY, appeared before me this day in person and acknowledged respectively, that they signed and delivered said instrument as their free and voluntary act for the uses and purposes therein set forth.

Given under my hand and notarial seal this _____ day of _____ A.D. _____

My commission expires _____

Notary Public

In lieu of completing the above section of the Proposal Bid Form, the Principal may file an Electronic Bid Bond. By signing the proposal and marking the check box next to the Signature and Title line below, the Principal is ensuring the identified electronic bid bond has been executed and the Principal and Surety are firmly bound unto the SPONSOR through its AGENT under the conditions of the bid bond as shown above.

Electronic Bid Bond ID# _____ Company / Bidder Name _____ Signature and Title _____



PROPOSALS

for construction work advertised for bids by the
Illinois Department of Transportation

Item No.	Item No.	Item No.

Submitted By:

Name:
Address:
Phone No.

Bidders should use an IDOT proposal envelope or affix this form to the front of a 10" x 13" envelope for the
submission of bids. If proposals are mailed, they should be enclosed in a second or outer envelope addressed to:

Engineer of Design and Environment - Room 326
Illinois Department of Transportation
2300 South Dirksen Parkway
Springfield, Illinois 62764

NOTICE

**Individual bids, including Bid Bond and/or supplemental information if required, should be securely
stapled.**

CONTRACTOR OFFICE COPY OF CONTRACT SPECIFICATIONS

NOTICE

None of the following material needs to be returned with the bid package unless the special provisions require documentation and/or other information to be submitted.

**Contract No. LK010
Lake in the Hills Airport
Lake in the Hills, Illinois
McHenry County
Illinois Project No. 3CK-4283
SBG Project No. TBD**



Illinois Department of Transportation

SUBCONTRACTOR DOCUMENTATION

Public Acts 96-0795, 96-0920, and 97-0895 enacted substantial changes to the provisions of the Code (30 ILCS 500). Among the changes are provisions affecting subcontractors. The Contractor awarded this contract will be required as a material condition of the contract to implement and enforce the contract requirements applicable to subcontractors that entered into a contractual agreement with a total value of \$50,000 or more with a person or entity who has a contract subject to the Code and approved in accordance with Section 80-01 of the Illinois Standard Specifications for Construction of Airports.

If the Contractor seeks approval of subcontractors to perform a portion of the work, and approval is granted by the Department, the Contractor shall provide a copy of the subcontract to the Illinois Department of Transportation's CPO upon request within 15 calendar days after execution of the subcontract.

Financial disclosures required pursuant to Section 50-35 of the Code must be submitted for all applicable subcontractors. The subcontract shall contain the certifications required to be made by subcontractors pursuant to Article 50 of the Code. This Notice to Bidders includes a document incorporating all required subcontractor certifications and disclosures for use by the Contractor in compliance with this mandate. The document is entitled State Required Ethical Standards Governing Subcontractors.

RETURN WITH SUBCONTRACT

STATE ETHICAL STANDARDS GOVERNING SUBCONTRACTORS

Article 50 of the Code establishes the duty of all State CPOs, SPOs, and their designees to maximize the value of the expenditure of public moneys in procuring goods, services, and contracts for the State of Illinois and to act in a manner that maintains the integrity and public trust of State government. In discharging this duty, they are charged by law to use all available information, reasonable efforts, and reasonable actions to protect, safeguard, and maintain the procurement process of the State of Illinois.

The certifications hereinafter made by the subcontractor are each a material representation of fact upon which reliance is placed should the Department approve the subcontractor. The CPO may terminate or void the contract approval if it is later determined that the bidder or subcontractor rendered a false or erroneous certification. If a false certification is made by a subcontractor the contractor's submitted bid and the executed contract may not be declared void unless the contractor refuses to terminate the subcontract upon the State's request after a finding that the subcontractor's certification was false.

Section 50-2 of the Code provides that every person that has entered into a multi-year contract and every subcontractor with a multi-year subcontract shall certify, by July 1 of each fiscal year covered by the contract after the initial fiscal year, to the responsible CPO whether it continues to satisfy the requirements of Article 50 pertaining to the eligibility for a contract award. If a contractor or subcontractor is not able to truthfully certify that it continues to meet all requirements, it shall provide with its certification a detailed explanation of the circumstances leading to the change in certification status. A contractor or subcontractor that makes a false statement material to any given certification required under Article 50 is, in addition to any other penalties or consequences prescribed by law, subject to liability under the Whistleblower Reward and Protection Act for submission of a false claim.

A. Bribery

1. The Code provides:

Section 50-5. Bribery.

(a) Prohibition. No person or business shall be awarded a contract or subcontract under this Code who:

(1) has been convicted under the laws of Illinois or any other state of bribery or attempting to bribe an officer or employee of the State of Illinois or any other state in that officer's or employee's official capacity; or

(2) has made an admission of guilt of that conduct that is a matter of record but has not been prosecuted for that conduct.

(b) Businesses. No business shall be barred from contracting with any unit of State or local government, or subcontracting under such a contract, as a result of a conviction under this Section of any employee or agent of the business if the employee or agent is no longer employed by the business and:

(1) the business has been finally adjudicated not guilty; or

(2) the business demonstrates to the governmental entity with which it seeks to contract, or which is signatory to the contract to which the subcontract relates, and that entity finds that the commission of the offense was not authorized, requested, commanded, or performed by a director, officer, or high managerial agent on behalf of the business as provided in paragraph (2) of subsection (a) of Section 5-4 of the Criminal Code of 1961.

(c) Conduct on behalf of business. For purposes of this Section, when an official, agent, or employee of a business committed the bribery or attempted bribery on behalf of the business and in accordance with the direction or authorization of a responsible official of the business, the business shall be chargeable with the conduct.

(d) Certification. Every bid submitted to and contract executed by the State, and every subcontract subject to Section 20-120 of the Code shall contain a certification by the contractor or the subcontractor, respectively, that the contractor or subcontractor is not barred from being awarded a contract or subcontract under this Section and acknowledges that the CPO may declare the related contract void if any certifications required by this Section are false. A contractor who makes a false statement, material to the certification, commits a Class 3 felony.

2. The contractor or subcontractor certifies that it is not barred from being awarded a contract under Section 50.5.

B. Felons

1. The Code provides:

Section 50-10. Felons. Unless otherwise provided, no person or business convicted of a felony shall do business with the State of Illinois or any State agency, or enter into a subcontract, from the date of conviction until 5 years after the date of completion of the sentence for that felony, unless no person held responsible by a prosecutorial office for the facts upon which the conviction was based continues to have any involvement with the business.

2. Certification. Every bid submitted to and contract executed by the State and every subcontract subject to Section 20-120 of the Code shall contain a certification by the bidder or contractor or subcontractor, respectively, that the bidder, contractor, or subcontractor is not barred from being awarded a contract or subcontract under this Section and acknowledges that the CPO may declare the related contract void if any of the certifications required by this Section are false.

RETURN WITH SUBCONTRACT

C. Debt Delinquency

1. The Code provides:

Section 50-11 and 50-12. Debt Delinquency.

The contractor or bidder or subcontractor, respectively, certifies that it, or any affiliate, is not barred from being awarded a contract or subcontract under the Code. Section 50-11 prohibits a person from entering into a contract with a State agency, or entering into a subcontract, if it knows or should know that it, or any affiliate, is delinquent in the payment of any debt to the State as defined by the Debt Collection Board. Section 50-12 prohibits a person from entering into a contract with a State agency, or entering into a subcontract, if it, or any affiliate, has failed to collect and remit Illinois Use Tax on all sales of tangible personal property into the State of Illinois in accordance with the provisions of the Illinois Use Tax Act. The bidder or contractor or subcontractor, respectively, further acknowledges that the CPO may declare the related contract void if this certification is false or if the bidder, contractor, or subcontractor, or any affiliate, is determined to be delinquent in the payment of any debt to the State during the term of the contract.

D. Prohibited Bidders, Contractors and Subcontractors

1. The Code provides:

Section 50-10.5 and 50-60(c). Prohibited bidders, contractors and subcontractors.

The bidder or contractor or subcontractor, respectively, certifies in accordance with 30 ILCS 500/50-10.5 that no officer, director, partner or other managerial agent of the contracting business has been convicted of a felony under the Sarbanes-Oxley Act of 2002 or a Class 3 or Class 2 felony under the Illinois Securities Law of 1953 or if in violation of Subsection (c) for a period of five years from the date of conviction. Every bid submitted to and contract executed by the State and every subcontract subject to Section 20-120 of the Code shall contain a certification by the bidder, contractor, or subcontractor, respectively, that the bidder, contractor, or subcontractor is not barred from being awarded a contract or subcontract under this Section and acknowledges that the CPO shall declare the related contract void if any of the certifications completed pursuant to this Section are false.

E. Section 42 of the Environmental Protection Act

The bidder or contractor or subcontractor, respectively, certifies in accordance with 30 ILCS 500/50-14 that the bidder, contractor, or subcontractor, is not barred from being awarded a contract or entering into a subcontract under this Section which prohibits the bidding on or entering into contracts with the State of Illinois or a State agency, or entering into any subcontract, that is subject to the Code by a person or business found by a court or the Pollution Control Board to have committed a willful or knowing violation of Section 42 of the Environmental Protection Act for a period of five years from the date of the order. The bidder or contractor or subcontractor, respectively, acknowledges that the CPO may declare the contract void if this certification is false.

The undersigned, on behalf of the subcontracting company, has read and understands the above certifications and makes the certifications as required by law.

<hr/>		
Name of Subcontracting Company		
<hr/>		<hr/>
Authorized Officer		Date

RETURN WITH SUBCONTRACT

SUBCONTRACTOR DISCLOSURES

I. DISCLOSURES

- A. The disclosures hereinafter made by the subcontractor are each a material representation of fact upon which reliance is placed. The subcontractor further certifies that the Department has received the disclosure forms for each subcontract.

The CPO may void the bid, contract, or subcontract, respectively, if it is later determined that the bidder or subcontractor rendered a false or erroneous disclosure. A contractor or subcontractor may be suspended or debarred for violations of the Code. Furthermore, CPO may void the contract.

B. Financial Interests and Conflicts of Interest

1. Section 50-35 of the Code provides that all subcontracts with a total value of \$50,000 or more from subcontractors identified in Section 20-120 of the Code shall be accompanied by disclosure of the financial interests of the subcontractor. This disclosed information for the subcontractor, will be maintained as public information subject to release by request pursuant to the Freedom of Information Act, filed with the Procurement Policy Board, and shall be incorporated as a material term of the Prime Contractor's contract. Furthermore, pursuant to this Section, the Procurement Policy Board may recommend to allow or void a contract or subcontract based on a potential conflict of interest.

The financial interests to be disclosed shall include ownership or distributive income share that is in excess of 5%, or an amount greater than 60% of the annual salary of the Governor, of the subcontracting entity or its parent entity, whichever is less, unless the subcontractor is a publicly traded entity subject to Federal 10K reporting, in which case it may submit its 10K disclosure in place of the prescribed disclosure. If a subcontractor is a privately held entity that is exempt from Federal 10K reporting, but has more than 400 shareholders, it may submit the information that Federal 10K companies are required to report, and list the names of any person or entity holding any ownership share that is in excess of 5%. The disclosure shall include the names, addresses, and dollar or proportionate share of ownership of each person making the disclosure, their instrument of ownership or beneficial relationship, and notice of any potential conflict of interest resulting from the current ownership or beneficial interest of each person making the disclosure having any of the relationships identified in Section 50-35 and on the disclosure form.

The current annual salary of the Governor is \$177,412.00.

In addition, all disclosures shall indicate any other current or pending contracts, subcontracts, proposals, leases, or other ongoing procurement relationships the subcontracting entity has with any other unit of state government and shall clearly identify the unit and the contract, subcontract, proposal, lease, or other relationship.

2. Disclosure Forms. Disclosure Form A is attached for use concerning the individuals meeting the above ownership or distributive share requirements. A separate Disclosure Form A must be submitted with the bid for each individual meeting the above requirements. In addition, a second form (Disclosure Form B) provides for the disclosure of current or pending procurement relationships with other (non-IDOT) state agencies and a total ownership certification. **The forms must be included with each bid.**

C. Disclosure Form Instructions

Form A Instructions for Financial Information & Potential Conflicts of Interest

If the subcontractor is a publicly traded entity subject to Federal 10K reporting, the 10K Report may be submitted to meet the requirements of Form A. If a subcontractor is a privately held entity that is exempt from Federal 10K reporting, but has more than 400 shareholders, it may submit the information that Federal 10K companies are required to report, and list the names of any person or entity holding any ownership share that is in excess of 5%. If a subcontractor is not subject to Federal 10K reporting, the subcontractor must determine if any individuals are required by law to complete a financial disclosure form. To do this, the subcontractor should answer each of the following questions. A "YES" answer indicates Form A must be completed. If the answer to each of the following questions is "NO", then the NOT APPLICABLE STATEMENT on the second page of Form A must be signed and dated by a person that is authorized to execute contracts for the subcontracting company. Note: These questions are for assistance only and are not required to be completed.

1. Does anyone in your organization have a direct or beneficial ownership share of greater than 5% of the bidding entity or parent entity?
YES _____ NO _____
2. Does anyone in your organization have a direct or beneficial ownership share of less than 5%, but which has a value greater than 60% of the annual salary of the Governor? YES _____ NO _____
3. Does anyone in your organization receive more than 60% of the annual salary of the Governor of the subcontracting entity's or parent entity's distributive income? (Note: Distributive income is, for these purposes, any type of distribution of profits. An annual salary is not distributive income.) YES _____ NO _____
4. Does anyone in your organization receive greater than 5% of the subcontracting entity's or parent entity's total distributive income, but which is less than 60% of the annual salary of the Governor? YES _____ NO _____

(Note: Only one set of forms needs to be completed per person per subcontract even if a specific individual would require a yes answer to more than one question.)

A "YES" answer to any of these questions requires the completion of Form A. The subcontractor must determine each individual in the subcontracting entity or the subcontracting entity's parent company that would cause the questions to be answered "Yes". Each form must be signed and dated by a person that is authorized to execute contracts for your organization. **Photocopied or stamped signatures are not acceptable.** The person signing can be, but does not have to be, the person for which the form is being completed. The subcontractor is responsible for the accuracy of any information provided.

If the answer to each of the above questions is "NO", then the NOT APPLICABLE STATEMENT on page 2 of Form A must be signed and dated by a person that is authorized to execute contracts for your company.

RETURN WITH SUBCONTRACT

Form B: Instructions for Identifying Other Contracts & Procurement Related Information

Disclosure Form B must be completed for each subcontract submitted by the subcontracting entity. *Note: Checking the NOT APPLICABLE STATEMENT on Form A does not allow the subcontractor to ignore Form B. Form B must be completed, checked, and dated or the subcontract will not be approved.*

The Subcontractor shall identify, by checking Yes or No on Form B, whether it has any pending contracts, subcontracts, leases, bids, proposals, or other ongoing procurement relationship with any other (non-IDOT) State of Illinois agency. If "No" is checked, the subcontractor only needs to complete the check box on the bottom of Form B. If "Yes" is checked, the subcontractor must list all non-IDOT State of Illinois agency pending contracts, subcontracts, leases, bids, proposals, and other ongoing procurement relationships. These items may be listed on Form B or on an attached sheet(s). Contracts with cities, counties, villages, etc. are not considered State of Illinois agency contracts and are not to be included. Contracts or subcontracts with other State of Illinois agencies such as the Department of Natural Resources or the Capital Development Board must be included.

**ILLINOIS DEPARTMENT
OF TRANSPORTATION**

**Form A
Subcontractor: Financial
Information & Potential Conflicts
of Interest Disclosure**

Subcontractor Name		
Legal Address		
City, State, Zip		
Telephone Number	Email Address	Fax Number (if available)

Disclosure of the information contained in this Form is required by the Section 50-35 of the Code (30 ILCS 500). Subcontractors desiring to enter into a subcontract of a State of Illinois contract must disclose the financial information and potential conflict of interest information as specified in this Disclosure Form. This information shall become part of the publicly available contract file. This Form A must be completed for subcontracts with a total value of \$50,000 or more, from subcontractors identified in Section 20-120 of the Code, and for all open-ended contracts. **A publicly traded company may submit a 10K disclosure (or equivalent if applicable) in satisfaction of the requirements set forth in Form A. See Disclosure Form Instructions.**

The current annual salary of the Governor is \$177,412.00.

DISCLOSURE OF FINANCIAL INFORMATION

1. Disclosure of Financial Information. The individual named below has an interest in the SUBCONTRACTOR (or its parent) in terms of ownership or distributive income share in excess of 5%, or an interest which has a value of more than 60% of the annual salary of the Governor. **(Make copies of this form as necessary and attach a separate Disclosure Form A for each individual meeting these requirements)**

FOR INDIVIDUAL (type or print information)	
NAME:	_____
ADDRESS	_____
Type of ownership/distributable income share:	
stock _____	sole proprietorship _____ Partnership _____ other: (explain on separate sheet):
% or \$ value of ownership/distributable income share: _____	

2. Disclosure of Potential Conflicts of Interest. Check "Yes" or "No" to indicate which, if any, of the following potential conflict of interest relationships apply. If the answer to any question is "Yes", please attach additional pages and describe.

(a) State employment, currently or in the previous 3 years, including contractual employment of services. Yes _____ No _____

If your answer is yes, please answer each of the following questions.

- Are you currently an officer or employee of either the Capitol Development Board or the Illinois State Toll Highway Authority? Yes _____ No _____
- Are you currently appointed to or employed by any agency of the State of Illinois? If you are currently appointed to or employed by any agency of the State of Illinois, and your annual salary exceeds 60% of the annual salary of the Governor, provide the name the State agency for which you are employed and your annual salary _____

RETURN WITH SUBCONTRACT

- 3. If you are currently appointed to or employed by any agency of the State of Illinois, and your annual salary exceeds 60% of the annual salary of the Governor, are you entitled to receive (i) more than 7 1/2% of the total distributable income of your firm, partnership, association or corporation, or (ii) an amount in excess of 100% of the annual salary of the Governor? Yes _____ No _____
- 4. If you are currently appointed to or employed by any agency of the State of Illinois, and your annual salary exceeds 60% of the annual salary of the Governor, are you and your spouse or minor children entitled to receive (i) more than 15 % in the aggregate of the total distributable income of your firm, partnership, association or corporation, or (ii) an amount in excess of two times the salary of the Governor? Yes _____ No _____

(b) State employment of spouse, father, mother, son, or daughter, including contractual employment services in the previous 2 years. Yes _____ No _____

If your answer is yes, please answer each of the following questions.

- 1. Is your spouse or any minor children currently an officer or employee of the Capitol Development Board or the Illinois State Toll Highway Authority? Yes _____ No _____
- 2. Is your spouse or any minor children currently appointed to or employed by any agency of the State of Illinois? If your spouse or minor children is/are currently appointed to or employed by any agency of the State of Illinois, and his/her annual salary exceeds 60% of the annual salary of the Governor, provide the name of your spouse and/or minor children, the name of the State agency for which he/she is employed and his/her annual salary. _____
- 3. If your spouse or any minor children is/are currently appointed to or employed by any agency of the State of Illinois, and his/her annual salary exceeds 60% of the annual salary of the Governor, are you entitled to receive (i) more than 7 1/2% of the total distributable income of your firm, partnership, association or corporation, or (ii) an amount in excess of the salary of the Governor? Yes _____ No _____
- 4. If your spouse or any minor children are currently appointed to or employed by any agency of the State of Illinois, and his/her annual salary exceeds 60% of the annual salary of the Governor, are you and your spouse or minor children entitled to receive (i) more than 15 % in the aggregate of the total distributable income of your firm, partnership, association or corporation, or (ii) an amount in excess of 2 times the salary of the Governor? Yes _____ No _____

(c) Elective status; the holding of elective office of the State of Illinois, the government of the United States, any unit of local government authorized by the Constitution of the State of Illinois or the statutes of the State of Illinois currently or in the previous 3 years. Yes _____ No _____

(d) Relationship to anyone holding elective office currently or in the previous 2 years; spouse, father, mother, son, or daughter. Yes _____ No _____

(e) Appointive office; the holding of any appointive government office of the State of Illinois, the United States of America, or any unit of local government authorized by the Constitution of the State of Illinois or the statutes of the State of Illinois, which office entitles the holder to compensation in excess of the expenses incurred in the discharge of that office currently or in the previous 3 years. Yes _____ No _____

(f) Relationship to anyone holding appointive office currently or in the previous 2 years; spouse, father, mother, son, or daughter. Yes _____ No _____

(g) Employment, currently or in the previous 3 years, as or by any registered lobbyist of the State government. Yes _____ No _____

RETURN WITH SUBCONTRACT

(h) Relationship to anyone who is or was a registered lobbyist in the previous 2 years; spouse, father, mother, son, or daughter. Yes _____ No _____

(i) Compensated employment, currently or in the previous 3 years, by any registered election or reelection committee registered with the Secretary of State or any county clerk of the State of Illinois, or any political action committee registered with either the Secretary of State or the Federal Board of Elections. Yes _____ No _____

(j) Relationship to anyone; spouse, father, mother, son, or daughter; who was a compensated employee in the last 2 years by any registered election or re-election committee registered with the Secretary of State or any county clerk of the State of Illinois, or any political action committee registered with either the Secretary of State or the Federal Board of Elections. Yes _____ No _____

3. Communication Disclosure.

Disclose the name and address of each lobbyist and other agent of the bidder or offeror who is not identified in Section 2 of this form, who has communicated, is communicating, or may communicate with any State officer or employee concerning the bid or offer. This disclosure is a continuing obligation and must be promptly supplemented for accuracy throughout the process and throughout the term of the contract. If no person is identified, enter "None" on the line below:

Name and address of person(s): _____

RETURN WITH SUBCONTRACT

4. Debarment Disclosure. For each of the persons identified under Sections 2 and 3 of this form, disclose whether any of the following has occurred within the previous 10 years: debarment from contracting with any governmental entity; professional licensure discipline; bankruptcies; adverse civil judgments and administrative findings; and criminal felony convictions. This disclosure is a continuing obligation and must be promptly supplemented for accuracy throughout the procurement process and term of the contract. If no person is identified, enter "None" on the line below:

Name of person(s): _____

Nature of disclosure: _____

APPLICABLE STATEMENT

This Disclosure Form A is submitted on behalf of the INDIVIDUAL named on previous page. Under penalty of perjury, I certify the contents of this disclosure to be true and accurate to the best of my knowledge.

Completed by:

Signature of Individual or Authorized Officer

Date

NOT APPLICABLE STATEMENT

Under penalty of perjury, I have determined that no individuals associated with this organization meet the criteria that would require the completion of this Form A.

This Disclosure Form A is submitted on behalf of the SUBCONTRACTOR listed on the previous page.

Signature of Authorized Officer

Date

RETURN WITH SUBCONTRACT

ILLINOIS DEPARTMENT OF TRANSPORTATION

Form B Subcontractor: Other Contracts & Procurement Related Information Disclosure

Form with fields: Subcontractor Name, Legal Address, City, State, Zip, Telephone Number, Email Address, Fax Number (if available)

Disclosure of the information contained in this Form is required by the Section 50-35 of the Code (30 ILCS 500). This information shall become part of the publicly available contract file. This Form B must be completed for subcontracts with a total value of \$50,000 or more, from subcontractors identified in Section 20-120 of the Code, and for all open-ended contracts.

DISCLOSURE OF OTHER CONTRACTS, SUBCONTRACTS, AND PROCUREMENT RELATED INFORMATION

1. Identifying Other Contracts & Procurement Related Information. The SUBCONTRACTOR shall identify whether it has any pending contracts, subcontracts, including leases, bids, proposals, or other ongoing procurement relationship with any other State of Illinois agency: Yes _____ No _____ If "No" is checked, the subcontractor only needs to complete the signature box on the bottom of this page.

2. If "Yes" is checked. Identify each such relationship by showing State of Illinois agency name and other descriptive information such as bid or project number (attach additional pages as necessary). SEE DISCLOSURE FORM INSTRUCTIONS:

THE FOLLOWING STATEMENT MUST BE CHECKED

Signature box with fields: Signature of Authorized Officer, Date

OWNERSHIP CERTIFICATION

Please certify that the following statement is true if the individuals for all submitted Form A disclosures do not total 100% of ownership.

Any remaining ownership interest is held by individuals receiving less than \$106,447.20 of the bidding entity's or parent entity's distributive income or holding less than a 5% ownership interest.

Yes No N/A (Form A disclosure(s) established 100% ownership)



NOTICE TO BIDDERS

1. **TIME AND PLACE OF OPENING BIDS.** Sealed proposals for the improvement described herein will be received by the Department of Transportation at the Harry R. Hanley Building, 2300 South Dirksen Parkway in Springfield, Illinois until 10:00 o'clock a.m., August 2, 2013. All bids will be gathered, sorted, publicly opened and read in the auditorium at the Department of Transportation's Harry R. Hanley Building shortly after the 10:00 a.m. cut off time.

2. **DESCRIPTION OF WORK.** The proposed improvement is identified and advertised for bids in the Invitation for Bids as:

**Contract No. LK010
Lake in the Hills Airport
Lake in the Hills, Illinois
McHenry County
Illinois Project No. 3CK-4283
SBG Project No. TBD**

Construct Apron for the Fuel Facility and Relocate Fuel Facility

3. **INSTRUCTIONS TO BIDDERS.**

(a) This Notice, the invitation for bids, proposal and letter of award shall, together with all other documents in accordance with Article 10-18 of the Illinois Standard Specifications for Construction of Airports, become part of the contract. Bidders are cautioned to read and examine carefully all documents, to make all required inspections, and to inquire or seek explanation of the same prior to submission of a bid.

(b) State law, and, if the work is to be paid wholly or in part with Federal-aid funds, Federal law requires the bidder to make various certifications as a part of the proposal and contract. By execution and submission of the proposal, the bidder makes the certification contained therein. A false or fraudulent certification shall, in addition to all other remedies provided by law, be a breach of contract and may result in termination of the contract.

4. **AWARD CRITERIA AND REJECTION OF BIDS.** This contract will be awarded within 60 calendar days to the lowest responsive and responsible bidder considering conformity with the terms and conditions established by the Department in the proposal and contract documents. The issuance of plans and proposal forms for bidding based upon a prequalification rating shall not be the sole determinant of responsibility. The Department reserves the right to determine responsibility at the time of award, to reject any or all proposals, to readvertise the proposed improvement, and to waive technicalities.

5. **PRE-BID CONFERENCE.** There will be a pre-bid conference held at N/A at the Lake in the Hills Airport administration building. For engineering information, contact Matthew N. Demos, P.E. of Crawford, Murphy and Tilly, Inc. at (312) 357-2066.

6. **DISADVANTAGED BUSINESS POLICY.** The DBE goal for this contract is 7.9%.

7. **SPECIFICATIONS AND DRAWINGS.** The work shall be done in accordance with the Illinois Standard Specifications for Construction of Airports, the Illinois Division of Aeronautics Supplemental Specifications and Recurring Special Provisions, the Special Provisions dated July 8, 2013 and the Construction Plans dated July 8, 2013 as approved by the Department of Transportation, Division of Aeronautics.

8. **BIDDING REQUIREMENTS AND BASIS OF AWARD.** When alternates are included in the proposal, the following shall apply:

a. Additive Alternates

(1) Bidders must submit a bid for the Base Bid and for all Additive Alternates.

(2) Award of this contract will be made to the lowest responsible qualified bidder computed as follows:

The lowest aggregate amount of (i) the Base Bid plus (ii) any Additive Alternate(s) which the Department elects to award.

The Department may elect not to award any Additive Alternates. In that case, award will be to the lowest responsible qualified bidder of the Base Bid.

b. Optional Alternates

(1) Bidders must submit a bid for the Base Bid and for either Alternate A or Alternate B or for both Alternate A and Alternate B.

(2) Award of this contract will be made to the lowest responsible qualified bidder computed as follows:

The lower of the aggregate of either (i) the Base Bid plus Alternate A or (ii) the Base Bid plus Alternate B.

9. CONTRACT TIME. The Contractor shall complete all work within the specified contract time. Any calendar day extension beyond the specified contract time must be fully justified, requested by the Contractor in writing, and approved by the Engineer, or be subject to liquidated damages.

The contract time for this contract is 59 calendar days.

10. INDEPENDENT WEIGHT CHECKS. The Department reserves the right to conduct random unannounced independent weight checks on any delivery for bituminous, aggregate or other pay item for which the method of measurement for payment is based on weight. The weight checks will be accomplished by selecting, at random, a loaded truck and obtaining a loaded and empty weight on an independent scale. In addition, the department may perform random weight checks by obtaining loaded and empty truck weights on portable scales operated by department personnel.

11. GOOD FAITH COMPLIANCE. The Illinois Department of Transportation has made a good faith effort to include all statements, requirements, and other language required by federal and state law and by various offices within federal and state governments whether that language is required by law or not. If anything of this nature has been left out or if additional language etc. is later required, the bidder/contractor shall cooperate fully with the Department to modify the contract or bid documents to correct the deficiency. If the change results in increased operational costs, the Department shall reimburse the contractor for such costs as it may find to be reasonable.

By Order of the
Illinois Department of Transportation

Susan R. Shea, Ph.D.,
Director, Division of Aeronautics

ILLINOIS DEPARTMENT OF TRANSPORTATION
DIVISION OF AERONAUTICS

**REQUIRED CONTRACT PROVISIONS FOR FEDERALLY FUNDED AIRPORT CONSTRUCTION
CONTRACTS**

The work in this contract is included in the federal FAA Airport Improvement Program and is being undertaken and accomplished by the Illinois Department of Transportation, Division of Aeronautics and the Municipality, hereinafter called the Co-Sponsors, in accordance with the terms and conditions of a Grant Agreement between the Co-Sponsors and the United States, under the Airport and Airway Improvement Act of 1982 (Public Law 97-248; Title V, Section 501 et seq., September 3, 1982; 96 Stat. 671; codified at 49 U.S.C Section 2201 et seq.) and Part 152 of the Federal Aviation Regulations (14 CFR Part 152), pursuant to which the United States has agreed to pay a certain percentage of the costs of the Project that are determined to be allowable Project costs under the Act. The United States is not a party to this contract and no reference in this contract to FAA or representative thereof, or to any rights granted to the FAA or any representative thereof, or the United States, by the contract, makes the United States a party to this contract.

Consent of Assignment. The Contractor shall obtain the prior written consent of the Co-Sponsors to any proposed assignment of any interest in or part of this contract.

Provisions for all Construction Contracts

BUY AMERICAN PREFERENCE (Title 49 U.S.C., Chapter 501)

- (a) The Aviation Safety and Capacity Expansion Act of 1990 provides that preference be given to steel and manufactured products produced in the United States when funds are expended pursuant to a grant issued under the Airport Improvement Program (AIP).
- (b) Any and all steel products used in the performance of this contract by the Contractor, subcontractors, producers, and suppliers are required to adhere to the Illinois Steel Products Procurement Act, which requires that all steel items be of 100 percent domestic origin and manufacture. Any products listed under the Federal Aviation Administration's (FAA) nationwide approved list of "Equipment Meeting Buy American Requirements" shall be deemed as meeting the requirements of the Illinois Steel Products Procurement Act.
- (c) The successful bidder will be required to assure that only domestic steel and domestically manufactured products will be used by the Contractor, subcontractors, producers, and suppliers in the performance of this contract. The North American Free Trade Agreement (NAFTA) specifically excluded federal grant programs such as the AIP. Therefore, NAFTA does not change the requirement to comply with the Buy American requirement in the Act. Exceptions to this are for products, other than steel, that:
 - (1) the FAA has determined, under the Aviation Safety and Capacity Expansion Act of 1990, are not produced in the United States in sufficient and reasonably available quantities or of a satisfactory quality;
 - (2) the FAA has determined, under the Aviation Safety and Capacity Expansion Act of 1990, that domestic preference would be inconsistent with the public interest;
 - (3) the FAA has determined that inclusion of domestic material will increase the cost of the overall project contract by more than 25 percent; or
 - (4) the FAA has determined, under the Aviation Safety and Capacity Expansion Act of 1990,
 - (i) the cost of components and subcomponents produced in the United States is more than 60 percent of the cost of all components of the facility or equipment, and
 - (ii) final assembly of the facility or equipment has occurred in the United States.

The FAA must grant waivers for any items that are included in these above exceptions. Bidders can review items already approved under the FAA nationwide approved list of "Equipment Meeting Buy American Requirements" on the FAA website, which do not require a specific FAA waiver.

All waivers are the responsibility of the Contractor, must be obtained prior to the Notice to Proceed, and must be submitted to the Division of Aeronautics for review and approval before being forwarded to the FAA. Any products used on the project that cannot meet the domestic requirement, and for which a waiver prior to the Notice to Proceed was not obtained, will be rejected for use and subject to removal and replacement with no additional compensation, and the contractor deemed non-responsive.

CIVIL RIGHTS ACT OF 1964, TITLE VI – CONTRACTOR CONTRACTUAL REQUIREMENTS (Title 49 CFR Part 21)

During the performance of this contract, the contractor, for itself, its assignees and successors in interest (hereinafter referred to as the "contractor") agrees as follows:

1.1 Compliance with Regulations. The contractor shall comply with the Regulations relative to nondiscrimination in federally assisted programs of the Department of Transportation (hereinafter, "DOT") Title 49, Code of Federal Regulations, Part 21, as they may be amended from time to time (hereinafter referred to as the Regulations), which are herein incorporated by reference and made a part of this contract.

1.2 Nondiscrimination. The contractor, with regard to the work performed by it during the contract, shall not discriminate on the grounds of race, color, or national origin in the selection and retention of subcontractors, including procurements of materials and leases of equipment. The contractor shall not participate either directly or indirectly in the discrimination prohibited by section 21.5 of the Regulations, including employment practices when the contract covers a program set forth in Appendix B of the Regulations.

1.3 Solicitations for Subcontracts, Including Procurements of Materials and Equipment. In all solicitations either by competitive bidding or negotiation made by the contractor for work to be performed under a subcontract, including procurements of materials or leases of equipment, each potential subcontractor or supplier shall be notified by the contractor of the contractor's obligations under this contract and the Regulations relative to nondiscrimination on the grounds of race, color, or national origin.

1.4 Information and Reports. The contractor shall provide all information and reports required by the Regulations or directives issued pursuant thereto and shall permit access to its books, records, accounts, other sources of information, and its facilities as may be determined by the Co-Sponsors or the Federal Aviation Administration (FAA) to be pertinent to ascertain compliance with such Regulations, orders, and instructions. Where any information required of a contractor is in the exclusive possession of another who fails or refuses to furnish this information, the contractor shall so certify to the Co-Sponsors or the FAA, as appropriate, and shall set forth what efforts it has made to obtain the information.

1.5 Sanctions for Noncompliance. In the event of the contractor's noncompliance with the nondiscrimination provisions of this contract, the Co-Sponsor shall impose such contract sanctions as it or the FAA may determine to be appropriate, including, but not limited to:

- a. Withholding of payments to the contractor under the contract until the contractor complies, and/or
- b. Cancellation, termination, or suspension of the contract, in whole or in part.

1.6 Incorporation of Provisions. The contractor shall include the provisions of paragraphs 1 through 5 in every subcontract, including procurements of materials and leases of equipment, unless exempt by the Regulations or directives issued pursuant thereto. The contractor shall take such action with respect to any subcontract or procurement as the Co-Sponsor or the FAA may direct as a means of enforcing such provisions including sanctions for noncompliance. Provided, however, that in the event a contractor becomes involved in, or is threatened with, litigation with a subcontractor or supplier as a result of such direction, the contractor may request the Co-Sponsor to enter into such litigation to protect the interests of the Co-Sponsor and, in addition, the contractor may request the United States to enter into such litigation to protect the interests of the United States.

AIRPORT AND AIRWAY IMPROVEMENT ACT OF 1982, SECTION 520 - GENERAL CIVIL RIGHTS PROVISIONS (Title 49 U.S.C. 47123)

The contractor assures that it will comply with pertinent statutes, Executive orders and such rules as are promulgated to assure that no person shall, on the grounds of race, creed, color, national origin, sex, age, or handicap be excluded from participating in any activity conducted with or benefiting from Federal assistance. This provision obligates the tenant/concessionaire/lessee or its transferee for the period during which Federal assistance is extended to the airport a program, except where Federal assistance is to provide, or is in the form of personal property or real property or interest therein or structures or improvements thereon. In these cases the provision obligates the party or any transferee for the longer of the following periods: (a) the period during which the property is used by the airport sponsor or any transferee for a purpose for which Federal assistance is extended, or for another purpose involving the provision of similar services or benefits or (b) the period during which the airport sponsor or any transferee retains ownership or possession of the property. In the case of contractors, this provision binds the contractors from the bid solicitation period through the completion of the contract. This provision is in addition to that required of Title VI of the Civil Rights Act of 1964.

LOBBYING AND INFLUENCING FEDERAL EMPLOYEES (Title 49 CFR Part 20)

The undersigned bidder certifies, to the best of his or her knowledge and belief, that:

- (1) No Federal appropriated funds have paid or will be paid, by or behalf of the undersigned, to any person for influencing or attempting to influence an officer or employee of any agency, a Member of Congress, an Officer or employee of Congress, or an employee of a Member of Congress in connection with the awarding of any Federal contract, the making of any Federal grant, the making of any Federal loan, the entering into of any cooperative agreement, and the extension, continuation, renewal, amendment, or modification of any Federal contract, grant, loan, or cooperative agreement.
- (2) If any funds other than Federal appropriated funds have been paid or will be paid to any person for influencing or attempting to influence an officer or employee of any agency, a Member of Congress, an officer or employee of Congress, or an employee of a Member of Congress in connection with this Federal contract, grant, loan, or cooperative agreement, the undersigned shall complete and submit Standard Form-LLL, "Disclosure Form to Report Lobbying", in accordance with its instructions.
- (3) The undersigned shall require that the language of this certification be included in the award documents for all subawards at all tiers (including subcontracts, subgrants, and contracts under grants, loans, and cooperative agreements) and that all subrecipients shall certify and disclose accordingly.

This certification is a material representation of fact upon which reliance was placed when this transaction was made or entered into. Submission of this certification is a prerequisite for making or entering into this transaction imposed by Section 1352, title 31, U.S. Code. Any person who fails to file the required certification shall be subject to a civil penalty of not less than \$10,000 and not more than \$100,000 for each such failure.

ACCESS TO RECORDS AND REPORTS (Title 49 CFR Part 18.36)

The Contractor shall maintain an acceptable cost accounting system. The Co-Sponsors, the FAA, and the Comptroller General of the United States shall have access to any books, documents, paper, and records of the Contractor which are directly pertinent to the specific contract for the purposes of making an audit, examination, excerpts, and transcriptions. The Contractor shall maintain all required records for three years after the Co-Sponsor makes final payment and all other pending matters are closed.

DISADVANTAGED BUSINESS ENTERPRISES (Title 49 CFR Part 26)

Contract Assurance (§26.13) - The contractor or subcontractor shall not discriminate on the basis of race, color, national origin, or sex in the performance of this contract. The contractor shall carry out applicable requirements of 49 CFR Part 26 in the award and administration of DOT assisted contracts. Failure by the contractor to carry out these requirements is a material breach of this contract, which may result in the termination of this contract or such other remedy, as the recipient deems appropriate.

ENERGY CONSERVATION REQUIREMENTS (Title 49 CFR Part 18.36)

The contractor agrees to comply with mandatory standards and policies relating to energy efficiency that are contained in the state energy conservation plan issued in compliance with the Energy Policy and Conservation Act (Public Law 94-163)

BREACH OF CONTRACT TERMS (Title 49 CFT Part 18.36)

Any violation or breach of terms of this contract on the part of the contractor or their subcontractors may result in the suspension or termination of this contract or such other action that may be necessary to enforce the rights of the parties of this agreement. The duties and obligations imposed by the Contract Documents and the rights and remedies available thereunder shall be in addition to and not a limitation of any duties, obligations, rights and remedies otherwise imposed or available by law.

RIGHTS TO INVENTIONS (Title 49 CFR Part 18.36)

All rights to inventions and materials generated under this contract are subject to Illinois law and to regulations issued by the FAA and the Co-Sponsors of the Federal grant under which this contract is executed.

TRADE RESTRICTION CLAUSE (Title 49 CFR Part30)

The Contractor or subcontractor, by submission of an offer and/or execution of a contract, certifies that it:

- a. is not owned or controlled by one or more citizens or nationals of a foreign country included in the list of countries that discriminate against U.S. firms published by the Office of the United States Trade Representative (USTR);
- b. has not knowingly entered into any contract or subcontract for this project with a Contractor that is a citizen or national of a foreign country on said list, or is owned or controlled directly or indirectly by one or more citizens or nationals of a foreign country on said list.

- c. has not procured any product nor subcontracted for the supply of any product for use on the project that is produced in a foreign country on said list.

Unless the restrictions of this clause are waived by the Secretary of Transportation in accordance with 49 CFR 30.17, no contract shall be awarded to a Contractor or subcontractor who is unable to certify to the above. If the Contractor knowingly procures or subcontracts for the supply of any product or service of a foreign country on the said list for use on the project, the Federal Aviation Administration may direct, through the Co-Sponsors, cancellation of the contract at no cost to the Government.

Further, the Contractor agrees that, if awarded a contract resulting from this solicitation, it will incorporate this provision for certification without modification in each contract and in all lower tier subcontracts. The Contractor may rely upon the certification of a prospective subcontractor unless it has knowledge that the certification is erroneous.

The Contractor shall provide immediate written notice to the Co-Sponsors if the Contractor learns that its certification or that of a subcontractor was erroneous when submitted or has become erroneous by reason of changed circumstances. The subcontractor agrees to provide immediate written notice to the Contractor, if at any time it learns that its certification was erroneous by reason of changed circumstances.

This certification is a material representation of fact upon which reliance was placed when making the award. If it is later determined that the Contractor or subcontractor knowingly rendered an erroneous certification, the Federal Aviation Administration may direct, through this Co-Sponsor, cancellation of the contract or subcontract for default at no cost to the Government.

Nothing contained in the foregoing shall be construed to require establishment of a system of records in order to render, in good faith, the certification required by this provision. The knowledge and information of a Contractor is not required to exceed that which is normally possessed by a prudent person in the ordinary course of business dealings.

This certification concerns a matter within the jurisdiction of an agency of the United States of America and the making of false, fictitious, or fraudulent certification may render the maker subject to prosecution under Title 18, United States Code, Section 1001.

VETERAN'S PREFERENCE (Title 49 U.S.C. 47112)

In the employment of labor (except in executive, administrative, and supervisory positions), preference shall be given to Veterans of the Vietnam era and disabled veterans as defined in Section 515(c)(1) and (2) of the Airport and Airway Improvement Act of 1982. However, this preference shall apply only where the individuals are available and qualified to perform the work to which the employment relates.

Additional Provisions for Construction Contracts Exceeding \$2,000

DAVIS BACON LABOR PROVISIONS (Title 29 Part 5)

(1) Minimum Wages.

(i) All laborers and mechanics employed or working upon the site of the work will be paid unconditionally and not less often than once a week, and without subsequent deduction or rebate on any account (except such payroll deductions as are permitted by regulations issued by the Secretary of Labor under the Copeland Act (29 CFR Part 3)), the full amount of wages and bona fide fringe benefits (or cash equivalents thereof) due at time of payment computed at rates not less than those contained in the wage determination of the Secretary of Labor.

Contributions made or costs reasonably anticipated for bona fide fringe benefits under section 1(b)(2) of the Davis-Bacon Act on behalf of laborers or mechanics are considered wages paid to such laborers or mechanics, subject to the provision of paragraph (a)(1)(iv) of this section; also, regular contributions made or costs incurred for more than a weekly period (but not less often than quarterly) under plans, funds, or programs which cover the particular weekly period, are deemed to be constructively made or incurred during such weekly period. Such laborers and mechanics shall be paid the appropriate wage rate and fringe benefits on the wage determination for the classification of work actually performed, without regard to skill, except as provided in paragraph 5.5(a)(4). Laborers or mechanics performing work in more than one classification may be compensated at the rate specified for each classification for the time actually worked therein: *Provided*, That the employer's payroll records accurately set forth the time spent in each classification in which work is performed. The wage determination (including any additional classification and wage rates conformed under paragraph (a)(1)(ii) of this section) and the Davis-Bacon poster (WH-1321) shall be posted at all times by the Contractor and its subcontractors at the site of the work in a prominent and accessible place where it can be easily seen by the workers.

(ii)(A) The contracting officer shall require that any class of laborers or mechanics which is not listed in the wage determination and which is to be employed under the contract shall be classified in conformance with the wage determination. The contracting officer shall approve an additional classification and wage rate and fringe benefits therefore only when the following criteria have been met:

- (1)The work to be performed by the classification requested is not performed by a classification in the wage determination;
- and

(2)The classification is utilized in the area by the construction industry; and

(3)The proposed wage rate, including any bona fide fringe benefits, bears a reasonable relationship to the wage rates contained in the wage determination.

(B) If the Contractor and the laborers and mechanics to be employed in the classification (if known), or their representatives, and the contracting officer agree on the classification and wage rate (including the amount designated for fringe benefits where appropriate), a report of the action taken shall be sent by the contracting officer to the Administrator of the Wage and Hour Division, Employment Standards Administration, U.S. Department of Labor, Washington, D.C. 20210. The Administrator, or an authorized representative, will approve, modify, or disapprove every additional classification action within 30 days of receipt and so advise the contracting officer or will notify the contracting officer within the 30-day period that additional time is necessary.

(C) In the event the Contractor, the laborers or mechanics to be employed in the classification or their representatives, and the contracting officer do not agree on the proposed classification and wage rate (including the amount designated for fringe benefits, where appropriate), the contracting officer shall refer the questions, including the views of all interested parties and the recommendation of the contracting officer, to the Administrator for determination. The Administrator, or an authorized representative, will issue a determination within 30 days of receipt and so advise the contracting officer or will notify the contracting officer within the 30-day period that additional time is necessary.

(D) The wage rate (including fringe benefits where appropriate) determined pursuant to subparagraphs (1)(ii) (B) or (C) of this paragraph, shall be paid to all workers performing work in the classification under this contract from the first day on which work is performed in the classification.

(iii) Whenever the minimum wage rate prescribed in the contract for a class of laborers or mechanics includes a fringe benefit which is not expressed as an hourly rate, the Contractor shall either pay the benefit as stated in the wage determination or shall pay another bona fide fringe benefit or an hourly cash equivalent thereof.

(iv) If the Contractor does not make payments to a trustee or other third person, the Contractor may consider as part of the wages of any laborer or mechanic the amount of any costs reasonably anticipated in providing bona fide fringe benefits under a plan or program, *Provided*, That the Secretary of Labor has found, upon the written request of the Contractor, that the applicable standards of the Davis-Bacon Act have been met. The Secretary of Labor may require the Contractor to set aside in a separate account assets for the meeting of obligations under the plan or program.

(2) Withholding.

The Federal Aviation Administration shall upon its own action or written request of an authorized representative of the Department of Labor withhold or cause to be withheld from the Contractor under this contract or any other Federal contract with the same prime Contractor, or any other Federally-assisted contract subject to Davis-Bacon prevailing wage requirements, which is held by the same prime Contractor, so much of the accrued payments or advances as may be considered necessary to pay laborers and mechanics, including apprentices, trainees, and helpers, employed by the Contractor or any subcontractor the full amount of wages required by the contract. In the event of failure to pay any laborer or mechanic, including any apprentice, trainee, or helper, employed or working on the site of the work, all or part of the wages required by the contract, the (Agency) may, after written notice to the Contractor, sponsor, applicant, or owner, take such action as may be necessary to cause the suspension of any further payment, advance, or guarantee of funds until such violations have ceased.

(3) Payrolls and basic records.

(i) Payrolls and basic records relating thereto shall be maintained by the Contractor during the course of the work and preserved for a period of three years thereafter for all laborers and mechanics working at the site of the work. Such records shall contain the name, address, and social security number of each such work, his or her correct classification, hourly rates of wages paid (including rates of contributions or costs anticipated for bona fide fringe benefits or cash equivalents thereof of the types described in section 1(b)(2)(B) of the Davis-Bacon Act), daily and weekly number of hours worked, deductions made and actual wages paid. Whenever the Secretary of Labor has found under 29 CFR 5.5(a)(1)(iv) that the wages of any laborer or mechanic include the amount of any costs reasonably anticipated in providing benefits under a plan or program described in section 1(b)(2)(B) of the Davis-Bacon Act, the Contractor shall maintain records which show that the commitment to provide such benefits is enforceable, that the plan or program is financially responsible, and that the plan or program has been communicated in writing to the laborers or mechanics affected, and records which show the costs anticipated or the actual cost incurred in providing such benefits. Contractors employing apprentices or trainees under approved programs shall maintain written evidence of the registration of apprenticeship programs and certification of trainee programs, the registration of the apprentices and trainees, and the ratios and wage rates prescribed in the applicable programs.

(ii)(A) The Contractor shall submit weekly for each week in which any contract work is performed a copy of all payrolls to the Federal Aviation Administration if the agency is a party to the contract, but if the agency is not such a party, the Contractor will submit the payrolls to the applicant, sponsor, or owner, as the case may be, for transmission to the Federal Aviation Administration. The payrolls submitted shall set out accurately and completely all of the information required to be maintained under paragraph 5.5(a)(3)(i) of Regulations, 29 CFR Part 5. This information may be submitted in any form desired. Optional Form WH-347 is available for this purpose and may be purchased from the Superintendent of Documents (Federal Stock Number 029-005-00014-

1), U.S. Government Printing Office, Washington, D.C. 20402. The prime Contractor is responsible for the submission of copies of payrolls by all subcontractors.

(B) Each payroll submitted shall be accompanied by a "Statement of Compliance," signed by the Contractor, or subcontractor or his or her agent who pays or supervises the payment of the persons employed under the contract and shall certify the following:

(1) That the payroll for the payroll period contains the information required to be maintained under paragraph (3)(i) above and that such information is correct and complete;

(2) That each laborer or mechanic (including each helper, apprentice, and trainee) employed on the contract during the payroll period has been paid the full weekly wages earned, without rebate, either directly or indirectly, and that no deductions have been made either directly or indirectly from the full wages earned, other than permissible deductions as set forth in Regulations, 29 CFR Part 3;

(3) That each laborer or mechanic has been paid not less than the applicable wage rates and fringe benefits or cash equivalents for the classification of work performed as specified in the applicable wage determination incorporated into the contract.

(C) The weekly submission of a properly executed certification set forth on the reverse side of Optional Form WH-347 shall satisfy the requirement for submission of the "Statement of Compliance" required by paragraph (3)(ii)(B) of this section.

(D) The falsification of any of the above certifications may subject the Contractor or subcontractor to civil or criminal prosecution under Section 1001 of Title 18 and Section 231 of Title 31 of the United States Code.

(iii) The Contractor or subcontractor shall make the records required under paragraph (3)(i) of this section available for inspection, copying, or transcription by authorized representatives of the (write the name of the agency) or the Department of Labor, and shall permit such representatives to interview employees during working hours on the job. If the Contractor or subcontractor fails to submit the required records or to make them available, the Federal agency may, after written notice to the Contractor, sponsor, applicant, or owner, take such action as may be necessary to cause the suspension of any further payment, advance, or guarantee of funds. Furthermore, failure to submit the required records upon request or to make such records available may be grounds for debarment action pursuant to 29 CFR 5.12.

(4) Apprentices and Trainees

(i) Apprentices. Apprentices will be permitted to work at less than the predetermined rate for the work they performed when they are employed pursuant to and individually registered in a bona fide apprenticeship program registered with the U.S. Department of Labor, Employment and Training Administration, Bureau of Apprenticeship and Training, or with a State Apprenticeship Agency recognized by the Bureau, or if a person is employed in his or her first 90 days of probationary employment as an apprentice in such an apprenticeship program, who is not individually registered in the program, but who has been certified by the Bureau of Apprenticeship and Training or a State Apprenticeship Agency (where appropriate) to be eligible for probationary employment as an apprentice. The allowable ratio of apprentices to journeymen on the job site in any craft classification shall not be greater than the ratio permitted to the Contractor as to the entire work force under the registered program. Any worker listed on a payroll at an apprentice wage rate, who is not registered or otherwise employed as stated above, shall be paid not less than the applicable wage rate on the wage determination for the classification of work actually performed. In addition, any apprentice performing work on the job site in excess of the ratio permitted under the registered program shall be paid not less than the applicable wage rate on the wage determination for the work actually performed. Where a Contractor is performing construction on a project in a locality other than that in which its program is registered, the ratios and wage rates (expressed in percentages of the journeyman's hourly rate) specified in the Contractor's or subcontractor's registered program shall be observed. Every apprentice must be paid at not less than the rate specified in the registered program for the apprentice's level of progress, expressed as a percentage of the journeymen hourly rate specified in the applicable wage determination. Apprentices shall be paid fringe benefits in accordance with the provisions of the apprenticeship program. If the apprenticeship program does not specify fringe benefits, apprentices must be paid the full amount of fringe benefits listed on the wage determination for the applicable classification. If the Administrator determines that a different practice prevails for the applicable apprentice classification, fringes shall be paid in accordance with that determination. In the event the Bureau of Apprenticeship and Training, or a State Apprenticeship Agency recognized by the Bureau, withdraws approval of an apprenticeship program, the Contractor will no longer be permitted to utilize apprentices at less than the applicable predetermined rate for the work performed until an acceptable program is approved.

(ii) Trainees. Except as provided in 29 CFR 5.16, trainees will not be permitted to work at less than the predetermined rate for the work performed unless they are employed pursuant to and individually registered in a program which has received prior approval, evidenced by formal certification by the U.S. Department of Labor, Employment and Training Administration. The ratio of trainees to journeymen on the job site shall not be greater than permitted under the plan approved by the Employment and Training Administration. Every trainee must be paid at not less than the rate specified in the approved program for the trainee's level of progress, expressed as a percentage of the journeyman hourly rate specified in the applicable wage determination. Trainees shall be paid fringe benefits in accordance with the provisions of the trainee program. If the trainee program does not mention fringe benefits, trainees shall be paid the full amount of fringe benefits listed on the wage determination unless the Administrator of the Wage and Hour Division determines that there is an apprenticeship program associated with the corresponding journeyman wage rate on the wage determination which provides for less than full fringe benefits for apprentices. Any employee listed on the payroll at a trainee rate who is not registered and participating in a training plan approved by the Employment and Training Administration

shall be paid not less than the applicable wage rate on the wage determination for the classification of work actually performed. In addition, any trainee performing work on the job site in excess of the ration permitted under the registered program shall be paid not less than the applicable wage rate on the wage determination for the work actually performed. In the event the Employment and Training Administration withdraws approval of a training program, the contract will no longer be permitted to utilize trainees at less than the applicable predetermined rate for the work performed until an acceptable program is approved.

(iii) Equal employment opportunity. The utilization of apprentices, trainees and journeymen under this part shall be in conformity with the equal employment opportunity requirements of Executive Order 11246, as amended, and 29 CFR Part 30.

(5) Compliance with Copeland Act Requirements.

The Contractor shall comply with the requirements of 29 CFR Part 3, which are incorporated by reference in this contract.

(6) Subcontracts.

The Contractor or subcontractor shall insert in any subcontracts the clauses contained in 29 CFR Part 5.5(a)(1) through (10) and such other clauses as the Federal Aviation Administration may by appropriate instructions require, and also a clause requiring the subcontractors to include these clauses in any lower tier subcontracts. The prime Contractor shall be responsible for the compliance by an subcontractor or lower tier subcontractor with all the contract clauses in 29 CFR Part 5.5.

(7) Contract Termination: Debarment.

A breach of these contract clauses paragraphs (1) through (10) of this section may be grounds for termination of the contract and for debarment as a Contractor and a subcontractor as provided in 29 CFR Part 5.12.

(8) Compliance with Davis-Bacon and Related Act Requirements.

All rulings and interpretations of the Davis-Bacon and Related Acts contained in 29 CFR Parts 1, 3, and 5 are herein incorporated by referenced in this contract.

(9) Disputes Concerning Labor Standards.

Disputes arising out of the labor standards provisions of this contract shall not be subject to the general disputes clause of this contract. Such disputes shall be resolved in accordance with the procedures of the Department of Labor set forth in 29 CFR Parts 5, 6, and 7. Disputes within the meaning of this clause include disputes between the Contractor (or any of its subcontractors) and the contracting agency, the U.S. Department of Labor, or the employees or their representatives.

(10) Certification of Eligibility.

(i) By entering into this contract, the Contractor certifies that neither it (nor he or she) nor any person or firm who has an interest in the Contractor's firm is a person or firm ineligible to be awarded Government contracts by virtue of section 3(a) of the Davis-Bacon Act or 29 CFR 5.12(a)(1).

(ii) No part of this contract shall be subcontracted to any person or firm ineligible for award of a Government contract by virtue of section 3(a) of the Davis-Bacon Act or 29 CFR 5.12(a)(1).

(iii) The penalty for making false statements is prescribed in the U.S. Criminal Code, 18 U.S.C. 1001.

MINIMUM WAGES FOR FEDERAL AND FEDERALLY ASSISTED CONSTRUCTION CONTRACTS

This project is funded, in part, with Federal-aid funds and, as such, is subject to the provisions of the Davis-Bacon Act of March 3, 1931, as amended (46 Sta. 1494, as amended, 40 U.S.C. 276a) and of other Federal statutes referred to in a 29 CFR Part 1, Appendix A, as well as such additional statutes as may from time to time be enacted containing provisions for the payment of wages determined to be prevailing by the Secretary of Labor in accordance with the Davis-Bacon Act and pursuant to the provisions of 29 CFR Part 1. The prevailing rates and fringe benefits shown in the General Wage Determination Decisions issued by the U.S. Department of Labor shall, in accordance with the provisions of the foregoing statutes, constitute the minimum wages payable on Federal and federally assisted construction projects to laborers and mechanics of the specified classes engaged on contract work of the character and in the localities described therein.

General Wage Determination Decisions, modifications and supersedes decisions thereto are to be used in accordance with the provisions of 29 CFR Parts 1 and 5. Accordingly, the applicable decision, together with any modifications issued, must be made a part of every contract for performance of the described work within the geographic area indicated as required by an applicable DBRA Federal prevailing wage law and 29 CFR Part 5. The wage rates and fringe benefits contained in the General Wage Determination Decision shall be the minimum paid by contractors and subcontractors to laborers and mechanics.

NOTICE

The most current **General Wage Determination Decisions** (wage rates) are available on the IDOT web site. They are located on the Letting and Bidding page at <http://www.dot.state.il.us/desenv/delett.html>.

In addition, ten (10) days prior to the letting, the applicable Federal wage rates will be e-mailed to subscribers. It is recommended that all contractors subscribe to the Federal Wage Rates List or the Contractor's Packet through IDOT's subscription service.

PLEASE NOTE: if you have already subscribed to the Contractor's Packet you will automatically receive the Federal Wage Rates.

The instructions for subscribing are at <http://www.dot.state.il.us/desenv/subsc.html>.

If you have any questions concerning the wage rates, please contact IDOT's Chief Contract Official at 217-782-7806.

Additional Provisions for Construction Contracts Exceeding \$10,000

EQUAL EMPLOYMENT OPPORTUNITY - 41 CFR PART 60-1.4(b)

During the performance of this contract, the contractor agrees as follows:

1. The contractor will not discriminate against any employee or applicant for employment because of race, color, religion, sex, or national origin. The contractor will take affirmative action to ensure that applicants are employed, and that employees are treated during employment without regard to their race, color, religion, sex, or national origin. Such action shall include, but not be limited to the following: Employment, upgrading, demotion, or transfer; recruitment or recruitment advertising; layoff or termination; rates of pay or other forms of compensation; and selection for training, including apprenticeship. The contractor agrees to post in conspicuous places, available to employees and applicants for employment, notices to be provided setting forth the provisions of this nondiscrimination clause.
2. The contractor will, in all solicitations or advertisements for employees placed by or on behalf of the contractor, state that all qualified applicants will receive considerations for employment without regard to race, color, religion, sex, or national origin.
3. The contractor will send to each labor union or representative of workers with which s/he has a collective bargaining agreement or other contract or understanding, a notice to be provided advising the said labor union or workers' representatives of the contractor's commitments under this section, and shall post copies of the notice in conspicuous places available to employees and applicants for employment.
4. The contractor will comply with all provisions of Executive Order 11246 of September 24, 1965, as amended, and of the rules, regulations, and relevant orders of the Secretary of Labor.
5. The contractor will furnish all information and reports required by Executive Order 11246 of September 24, 1965, and by rules, regulations, and orders of the Secretary of Labor, or pursuant thereto, and will permit access to his books, records, and accounts by the administering agency and the Secretary of Labor for purposes of investigation to ascertain compliance with such rules, regulations, and orders.
6. In the event of the contractor's noncompliance with the nondiscrimination clauses of this contract or with any of the said rules, regulations, or orders, this contract may be canceled, terminated or suspended in whole or in part and the contractor may be declared ineligible for further Government contracts or federally assisted construction contracts in accordance with procedure authorized in Executive Order 11246 of September 24, 1965, and such other sanctions may be imposed and remedies invoked as provided in Executive Order 11246 of September 24, 1965, or by rule, regulation, or order of the Secretary of Labor, or as otherwise provided by law.
7. The contractor will include the portion of the sentence immediately preceding paragraph (1) and the provisions of paragraphs (1) through (7) in every subcontract or purchase order unless exempted by rules, regulations, or orders of the Secretary of Labor issued pursuant to section 204 of Executive Order 11246 of September 24, 1965, so that such provisions will be binding upon each subcontractor or vendor. The contractor will take such action with respect to any subcontract or purchase order as the administering agency may direct as a means of enforcing such provision, including sanctions for noncompliance: *Provided, however*, that in the event a contractor becomes involved in, or is threatened with, litigation with a subcontractor or vendor as a result of such direction by the administering agency the contractor may request the United States to enter into such litigation to protect the interests of the United States.

CERTIFICATION OF NONSEGREGATED FACILITIES (41 CFR PART 60-1.8)

The federally-assisted construction contractor certifies that she or he does not maintain or provide, for his employees, any segregated facilities at any of his establishments and that she or he does not permit his employees to perform their services at any location, under his control, where segregated facilities are maintained. The federally-assisted construction contractor certifies that she or he will not

maintain or provide, for his employees, segregated facilities at any of his establishments and that she or he will not permit his employees to perform their services at any location under his control where segregated facilities are maintained. The federally-assisted construction contractor agrees that a breach of this certification is a violation of the Equal Opportunity Clause in this contract.

As used in this certification, the term "segregated facilities" means any waiting rooms, work areas, restrooms, and washrooms, restaurants and other eating areas, timeclocks, locker rooms and other storage or dressing areas, parking lots, drinking fountains, recreation or entertainment areas, transportation, and housing facilities provided for employees which are segregated by explicit directives or are, in fact, segregated on the basis of race, color, religion, or national origin because of habit, local custom, or any other reason. The federally-assisted construction contractor agrees that (except where she or he has obtained identical certifications from proposed subcontractors for specific time periods) she or he will obtain identical certifications from proposed subcontractors prior to the award of subcontracts exceeding \$10,000 which are not exempt from the provisions of the Equal Opportunity Clause and that she or he will retain such certifications in his files.

NOTICE OF REQUIREMENT FOR AFFIRMATIVE ACTION (Title 41 CFR Part 60-4.2)

1. The Offeror's or Bidder's attention is called to the "Equal Opportunity Clause" and the "Standard Federal Equal Employment Opportunity Construction Contract Specifications" set forth herein.

2. The goals and timetables for minority and female participation, expressed in percentage terms for the Contractor's aggregate workforce in each trade on all construction work in the covered area, are as follows:

APPENDIX A

The following goal for female utilization in each construction craft and trade shall apply to all Contractors holding Federal and federally assisted construction contracts and subcontracts in excess of \$10,000. The goal is applicable to the Contractor's total on-site construction workforce, regardless of whether or not part of that workforce is performing work on a Federal, federally assisted or nonfederally related construction contract or subcontract.

AREA COVERED (STATEWIDE)

Goals for Women apply nationwide.

GOAL

	Goal (percent)
Female Utilization.....	6.9

APPENDIX B

Until further notice, the following goals for minority utilization in each construction craft and trade shall apply to all Contractors holding Federal and federally-assisted construction contracts and subcontracts in excess of \$10,000. to be performed in the respective geographical areas. The goals are applicable to the Contractor's total on-site construction workforce, regardless of whether or not part of that workforce is performing work on a Federal, federally-assisted or nonfederally related construction contract or subcontract.

<u>Economic Area</u>	<u>Goal (percent)</u>
056 Paducah, KY:	
Non-SMSA Counties -	5.2
IL - Hardin, Massac, Pope	
KY - Ballard, Caldwell, Calloway, Carlisle, Crittenden,	
Fulton, Graves, Hickman, Livingston, Lyon, McCracken, Marshall	
080 Evansville, IN:	
Non-SMSA Counties -	3.5
IL - Edwards, Gallatin, Hamilton, Lawrence, Saline, Wabash, White	
IN - Dubois, Knox, Perry, Pike, Spencer	
KY - Hancock, Hopkins, McLean, Mublenberg, Ohio, Union, Webster	
081 Terre Haute, IN:	
Non-SMSA Counties -	2.5
IL - Clark, Crawford	
IN - Parke	

083 Chicago, IL:	
SMSA Counties:	19.6
1600 Chicago, IL -	
IL - Cook, DuPage, Kane, Lake, McHenry, Will	
3740 Kankakee, IL -	9.1
IL - Kankakee	
Non-SMSA Counties	18.4
IL - Bureau, DeKalb, Grundy, Iroquois, Kendall, LaSalle, Livingston,	
Putnam	
IN - Jasper, Laporte, Newton, Pulaski, Starke	
084 Champaign - Urbana, IL:	
SMSA Counties:	
1400 Champaign - Urbana - Rantoul, IL -	7.8
IL - Champaign	
Non-SMSA Counties -	4.8
IL - Coles, Cumberland, Douglas, Edgar, Ford, Piatt, Vermilion	
085 Springfield - Decatur, IL:	
SMSA Counties:	
2040 Decatur, IL -	7.6
IL - Macon	
7880 Springfield, IL -	4.5
IL - Mendard, Sangamon	
Non-SMSA Counties	4.0
IL - Cass, Christian, Dewitt, Logan, Morgan, Moultrie, Scott, Shelby	
086 Quincy, IL:	
Non-SMSA Counties	3.1
IL - Adams, Brown, Pike	
MO - Lewis, Marion, Pike, Ralls	
087 Peoria, IL:	
SMSA Counties:	
1040 Bloomington - Normal, IL -	2.5
IL - McLean	
6120 Peoria, IL -	4.4
IL - Peoria, Tazewell, Woodford	
Non-SMSA Counties -	3.3
IL - Fulton, Knox, McDonough, Marshall, Mason, Schuyler, Stark, Warren	
088 Rockford, IL:	
SMSA Counties:	
6880 Rockford, IL -	6.3
IL - Boone, Winnebago	
Non-SMSA Counties -	4.6
IL - Lee, Ogle, Stephenson	
098 Dubuque, IA:	
Non-SMSA Counties -	0.5
IL - JoDaviess	
IA - Atlamakee, Clayton, Delaware, Jackson, Winnesheik	
WI - Crawford, Grant, Lafayette	

099 Davenport, Rock Island, Moline, IA - IL:	
SMSA Counties:	
1960 Davenport, Rock Island, Moline, IA - IL -	4.6
IL - Henry, Rock Island	
IA - Scott	
Non-SMSA Counties -	3.4
IL - Carroll, Hancock, Henderson, Mercer, Whiteside	
IA - Clinton, DesMoines, Henry, Lee, Louisa, Muscatine	
MO - Clark	
107 St. Louis, MO:	
SMSA Counties:	
7040 St. Louis, MO - IL -	14.7
IL - Clinton, Madison, Monroe, St. Clair	
MO - Franklin, Jefferson, St. Charles, St. Louis, St. Louis City	
Non-SMSA Counties -	11.4
IL - Alexander, Bond, Calhoun, Clay, Effingham, Fayette, Franklin, Greene,	
Jackson, Jasper, Jefferson, Jersey, Johnson, Macoupin, Marion,	
Montgomery, Perry, Pulaski, Randolph, Richland, Union, Washington,	
Wayne, Williamson	
MO - Bollinger, Butler, Cape Girardeau, Carter, Crawford, Dent, Gasconade,	
Iron, Lincoln, Madison, Maries, Mississippi, Montgomery, Perry, Phelps,	
Reynolds, Ripley, St. Francois, St. Genevieve, Scott, Stoddard, Warren,	
Washington, Wayne	

These goals are applicable to all the Contractor's construction work (whether or not it is Federal or federally assisted) performed in the covered area. If the Contractor performs construction work in a geographical area located outside of the covered area, it shall apply the goals established for such geographical area where the work is actually performed. With regard to this second area, the Contractor also is subject to the goals for both its federally involved and nonfederally involved construction.

The Contractor's compliance with Executive Order and the regulations in 41 CFR Part 60-4 shall be based on its implementation of the Equal Opportunity Clause, specific affirmative action obligations required by the provisions and specifications set forth in its federally assisted contracts, and its efforts to meet the goals established for the geographical area where the contract resulting from this solicitation is to be performed. The hours of minority and female employment and training must be substantially uniform throughout the length of the contract, and in each trade, and the Contractor shall make a good faith effort to employ minorities and women evenly on each of its projects. The transfer of minority or female employees or trainees from Contractor to Contractor or from project to project for the sole purpose of meeting the Contractor's goals shall be a violation of the contract, the Executive Order and the regulations in 41 CFR Part 60-4. Compliance with the goals will be measured against the total work hours performed.

3. The Illinois Division of Aeronautics will provide written notification to the Director of the Office of Federal Contract Compliance Programs within 10 working days of award of any construction contract and/or subcontract in excess of \$10,000 at any tier for construction work under the contract resulting from this solicitation. This notification will list the name, address and telephone number of the subcontractor; employer identification number; estimated dollar amount of the subcontract; estimated starting and completion dates of the subcontract; and the geographical area in which the contract is to be performed.

4. As used in this Notice, and in the contract resulting from this solicitation, the "covered area" is the entire State of Illinois for the goal set forth in APPENDIX A and the county or counties in which the work is located for the goals set forth in APPENDIX B.

EQUAL EMPLOYMENT OPPORTUNITY SPECIFICATION (Title 41 CFR Part 60-4.3)

1. As used in these specifications:
 - a) "Covered area" means the geographical area described in the solicitation from which this contract resulted;
 - b) "Director" means Director, Office of Federal Contract Compliance Programs, United States Department of Labor, or any person to whom the Director delegates authority;
 - c) "Employer identification number" means the Federal Social Security number used on the Employer's Quarterly Federal Tax Return, U.S. Treasury Department Form 941;
 - d) "Minority" includes:
 - (i) Black (all persons having origins in any of the Black African racial groups not of Hispanic origin);
 - (ii) Hispanic (all persons of Mexican, Puerto Rican, Cuban, Central or South American or other Spanish Culture or origin, regardless of race);
 - (iii) Asian and Pacific Islander (all persons having origins in any of the original peoples of the Far East, Southeast Asia, the Indian Subcontinent, or the Pacific Islands); and
 - (iv) American Indian or Alaskan Native (all persons having origins in any of the original peoples of North America and maintaining identifiable tribal affiliations through membership and participation or community identification).

2. Whenever the Contractor, or any Subcontractor at any tier, subcontracts a portion of the work involving any construction trade, it shall physically include in each subcontract in excess of \$10,000. the provisions of these specifications and the Notice which contains the applicable goals for minority and female participation and which is set forth in the solicitations from which this contract resulted.
3. If the Contractor is participating (pursuant to 41 CFR 60-4.5) in a Hometown Plan approved by the U.S. Department of Labor in the covered area either individually or through an association, its affirmative action obligations on all work in the plan area (including goals and timetables) shall be in accordance with that Plan for those trades which have unions participating in the Plan. Contractors must be able to demonstrate their participation in and compliance with the provisions of any such Hometown Plan. Each Contractor or Subcontractor participating in an approved Plan is individually required to comply with its obligations under the EEO clause, and to make a good faith effort to achieve each goal under the Plan in each trade in which it has employees. The overall good faith performance by other Contractors or Subcontractors toward a goal in an approved Plan does not excuse any covered Contractor's or Subcontractor's failure to take good faith efforts to achieve the Plan goals and timetables.
4. The Contractor shall implement the specific affirmative action standards provided in paragraphs 7a through p of these specifications. The goals set forth in the solicitation from which this contract resulted are expressed as percentages of the total hours of employment and training of minority and female utilization the Contractor should reasonably be able to achieve in each construction trade in which it has employees in the covered area. Covered Construction Contractors performing construction work in geographical areas where they do not have a Federal or federally assisted construction contract shall apply the minority and female goals established for the geographical area where the work is being performed. Goals are published periodically in the Federal Register in notice form, and such notices may be obtained from any Office of Federal Contract Compliance Programs office or from Federal procurement contracting officers. The Contractor is expected to make substantially uniform progress toward its goals in each craft during the period specified.
5. Neither the provisions of any collective bargaining agreement, nor the failure by a union with whom the Contractor has a collective bargaining agreement, to refer either minorities or women shall excuse the Contractor's obligations under these specifications, Executive Order 11246, or the regulations promulgated pursuant thereto.
6. In order for the nonworking training hours of apprentices and trainees to be counted in meeting the goals, such apprentices and trainees must be employed by the Contractor during the training period, and the Contractor must have made a commitment to employ the apprentices and trainees at the completion of their training, subject to the availability of employment opportunities. Trainees must be trained pursuant to training programs approved by the U.S. Department of Labor.
7. The Contractor shall take specific affirmative actions to ensure equal employment opportunity. The evaluation of the Contractor's compliance with these specifications shall be based upon its effort to achieve maximum results from its actions. The Contractor shall document these efforts fully, and shall implement affirmative action steps at least as extensive as the following:
 - a) Ensure and maintain a working environment free of harassment, intimidation, and coercion at all sites, and in all facilities at which the Contractor's employees are assigned to work. The Contractor, where possible, will assign two or more women to each construction project. The Contractor shall specifically ensure that all foremen, superintendents, and other on-site supervisory personnel are aware of and carry out the Contractor's obligation to maintain such a working environment, with specific attention to minority or female individuals working as such sites or in such facilities.
 - b) Establish and maintain a current list of minority and female recruitment sources, provide written notification to minority and female recruitment sources and to community organizations when the Contractor or its unions have employment opportunities available, and maintain a record of the organizations' responses.
 - c) Maintain a current file of the names, addresses and telephone numbers of each minority and female off-the-street applicant and minority or female referral from a union, a recruitment source or community organization and of what action was taken with respect to each such individual. If such individual was sent to the union hiring hall for referral and was not referred back to the Contractor by the union or, if referred, not employed by the Contractor, this shall be documented in the file with the reason therefor, along with whatever additional actions the Contractors may have taken.
 - d) Provide immediate written notification to the Director when the union or unions with which the Contractor has a collective bargaining agreement has not referred to the Contractor a minority person or woman sent by the Contractor, or when the Contractor has other information that the union referral process has impeded the Contractor's efforts to meet its obligations.
 - e) Develop on-the-job training opportunities and/or participate in training programs for the area which expressly include minorities and women, including upgrading programs and apprenticeship and trainee programs relevant to the Contractor's employment needs, especially those programs funded or approved by the Department of Labor. The Contractor shall provide notice of these programs to the sources compiled under 7b above.

- f) Disseminate the Contractor's EEO policy by providing notice of the policy to unions and training programs and requesting their cooperation in assisting the Contractor in meeting its EEO obligations; by including it in any policy manual and collective bargaining agreements; by publicizing it in the company newspaper, annual report, etc.; by specific review of the policy with all management personnel and with all minority and female employees at least once a year; and by posting the company EEO policy on bulletin boards accessible to all employees at each location where construction work is performed.
 - g) Review, at least annually, the company's EEO policy and affirmative action obligations under these specifications with all employees having any responsibility for hiring, assignment, layoff, termination or other employment decisions including specific review of these items with onsite supervisory personnel such as Superintendents, General Foreman, etc., prior to the initiation of construction work at any job site. A written record shall be made and maintained identifying the time and place of these meetings, persons attending, subject matter discussed, and disposition of the subject matter.
 - h) Disseminate the Contractor's EEO policy externally by including it in any advertising in the news media, specifically including minority and female news media, and providing written notification to and discussing the Contractor's EEO policy with other Contractors and Subcontractors with whom the Contractor does or anticipates doing business.
 - i) Direct its recruitment efforts, both oral and written, to minority, female and community organizations, to schools with minority and female students and to minority and female recruitment and training organizations serving the Contractor's recruitment area and employment needs. Not later than one month prior to the date for the acceptance of applications for apprenticeship or other training by any recruitment source, the Contractor shall send written notification to organizations such as the above, describing the openings, screening procedures, and tests to be used in the selection process.
 - j) Encourage present minority and female employees to recruit other minority persons and women and, where reasonable, provide after school, summer and vacation employment to minority and female youth both on the site and in other areas of a Contractor's workforce.
 - k) Validate all tests and other selection requirements where there is an obligation to do so under 41 CFR Part 60-3.
 - l) Conduct, at least annually, an inventory and evaluation at least of all minority and female personnel for promotional opportunities and encourage these employees to seek or to prepare for, through appropriate training, etc., such opportunities.
 - m) Ensure that seniority practices, job classifications, work assignments and other personnel practices, do not have a discriminatory effect by continually monitoring all personnel and employment related activities to ensure that the EEO policy and the Contractor's obligations under these specifications are being carried out.
 - n) Ensure that all facilities and company activities are nonsegregated except that separate or single-user toilet and necessary changing facilities shall be provided to assure privacy between the sexes.
 - o) Document and maintain a record of all solicitations of offers for subcontracts from minority and female construction Contractors and suppliers, including circulation of solicitations to minority and female Contractor associations and other business associations.
 - p) Conduct a review, at least annually, of all supervisors' adherence to and performance under the Contractor's EEO policies and affirmative action obligations.
8. Contractors are encouraged to participate in voluntary associations which assist in fulfilling one or more of their affirmative action obligations (7a through p). The efforts of a Contractor association, joint Contractor-union, Contractor-community, or other similar group of which the Contractor is a member and participant, may be asserted as fulfilling any one or more of its obligations under 7a through p of these Specifications provided that the Contractor actively participates in the group, makes every effort to assure that the group has a positive impact on the employment of minorities and women in the industry, ensures that the concrete benefits of the program are reflected in the Contractor's minority and female workforce participation makes a good faith effort to meet its individual goals and timetables, and can provide access to documentation which demonstrates the effectiveness of actions taken on behalf of the Contractor. The obligation to comply, however, is the Contractor's and failure of such a group to fulfill an obligation shall not be a defense for the Contractor's noncompliance.
9. A single goal for minorities and a separate single goal for women have been established. The Contractor, however, is required to provide equal employment opportunity and to take affirmative action for all minority groups, both male and female, and all women, both minority and non-minority. Consequently, the Contractor may be in violation of the Executive Order if a particular group is employed in a substantially disparate manner (for example, even though the Contractor has achieved its goals for women generally, the Contractor may be in violation of the Executive Order if a specified minority group of women is underutilized).

10. The Contractor shall not use the goals and timetables or affirmative action standards to discriminate against any person because of race, color, religion, sex, or national origin.
11. The Contractor shall not enter into any Subcontract with any person or firm debarred from Government contracts pursuant to Executive Order 11246.
12. The Contractor shall carry out such sanctions and penalties for violation of these specifications and of the Equal Opportunity Clause, including suspension, termination and cancellation of existing subcontracts as may be imposed or ordered pursuant to Executive Order 11246, as amended, and its implementing regulations, by the Office of Federal Contract Compliance Programs. Any Contractor who fails to carry out such sanctions and penalties shall be in violation of these specifications and Executive Order 11246, as amended.
13. The Contractor, in fulfilling its obligations under these specifications, shall implement specific affirmative action steps, at least as extensive as those standards prescribed in paragraph 7 of these specifications, so as to achieve maximum results from its efforts to ensure equal opportunity. If the Contractor fails to comply with the requirements of the Executive Order, the implementing regulations, or these specifications, the Director shall proceed in accordance with 41 CFR 60-4.8.
14. The Contractor shall designate a responsible official to monitor all employment related activity to ensure that the company EEO policy is being carried out, to submit reports relating to the provisions hereof as may be required by the Government and to keep records. Records shall at least include for each employee the name, address, telephone numbers, construction trade, union affiliation if any, employee identification number when assigned, social security number, race, sex, status (e.g., mechanic, apprentice, trainee, helper, or laborer), dates of changes in status, hours worked per week in the indicated trade, rate of pay, and locations at which the work was performed. Records shall be maintained in an easily understandable and retrievable form; however, to the degree that existing records satisfy his requirement, Contractors shall not be required to maintain separate records.
15. Nothing herein provided shall be construed as a limitation upon the application of other laws which establish different standards of compliance or upon the application of requirements for the hiring of local or other area residents (e.g., those under the Public Works Employment Act of 1977 and the Community Development Block Grant Program).

TERMINATION OF CONTRACT (Title 49 CFR Part 18.36)

1. The Co-Sponsor may, by written notice, terminate this contract in whole or in part at any time, either for the Co-Sponsor's convenience or because of failure to fulfill the contract obligations. Upon receipt of such notice services shall be immediately discontinued (unless the notice directs otherwise) and all materials as may have been accumulated in performing this contract, whether completed or in progress, delivered to the Co-Sponsor.
2. If the termination is for the convenience of the Co-Sponsor, an equitable adjustment in the contract price shall be made, but no amount shall be allowed for anticipated profit on unperformed services.
3. If the termination is due to failure to fulfill the Contractor's obligations, the Co-Sponsor may take over the work and prosecute the same to completion by contract or otherwise. In such case, the Contractor shall be liable to the Co-Sponsor for any additional cost occasioned to the Co-Sponsor thereby.
4. If, after notice of termination for failure to fulfill contract obligations, it is determined that the Contractor had not so failed, the termination shall be deemed to have been effected for the convenience of the Co-Sponsor. In such event, adjustment in the contract price shall be made as provided in paragraph 2 of this clause.
5. The rights and remedies of the Co-Sponsor provided in this clause are in addition to any other rights and remedies provided by law or under this contract.

Additional Provisions for Construction Contracts Exceeding \$25,000

CERTIFICATION REGARDING DEBARMENT, SUSPENSION, INELIGIBILITY AND VOLUNTARY EXCLUSION (Title 49 CFR Part 29)

Instructions for Certification

1. By signing and submitting this proposal, the prospective primary participant is providing the certification set out below.
2. The inability of a person to provide the certification required below will not necessarily result in denial of participation in this covered transaction. The prospective participant shall submit an explanation of why it cannot provide the certification set out below. The certification or explanation will be considered in connection with the department or agency's determination whether to enter into this transaction. However, failure of the prospective primary participant to furnish a certification or an explanation shall disqualify such person from participation in this transaction.

3. The certification in this clause is a material representation of fact upon which reliance was placed when the department or agency determined to enter into this transaction. If it is later determined that the prospective primary participant knowingly rendered an erroneous certification in addition to other remedies available to the Federal Government, the department or agency may terminate this transaction for cause of default.
4. The prospective primary participant shall provide immediate written notice to the department or agency to whom this proposal is submitted if at any time the prospective primary participant learns that its certification was erroneous when submitted or has become erroneous by reason of changed circumstances.
5. The terms "covered transaction" "debarred" "suspended" "ineligible" "lower tier covered transaction" "participant" "person" "primary covered transaction" "principal" "proposal" and "voluntarily excluded" as used in this clause have the meaning set out in the Definitions and Coverage sections of the rules implementing Executive Order 12540. You may contact the department or agency to which this proposal is being submitted for assistance in obtaining a copy of those regulations.
6. The prospective primary participant agrees by submitting this proposal that should the proposed covered transaction be entered into, it shall not knowingly enter into any lower tier covered transaction with a person who is debarred, suspended, declared ineligible, or voluntarily excluded from participation in this covered transaction unless authorized by the department or agency entering into this transaction.
7. The prospective primary participant further agrees by submitting this proposal that it will include the clause titled "Certification Regarding Debarment, Suspension, Ineligibility and Voluntary Exclusion - Lower Tier Transaction", provided by the department or agency entering into this covered transaction without modification in all lower covered transactions and in all solicitations for lower covered transactions.
8. A participant in a covered transaction may rely upon a certification of a prospective participant in a lower tier covered transaction that it is not debarred, suspended, ineligible, or voluntarily excluded from the covered transaction unless it knows that the certification is erroneous. A participant may decide the method and frequency by which it determines the eligibility of its principals. Each participant may, but is not required to check the Nonprocurement List (Tel. #).
9. Nothing contained in the foregoing shall be construed to require establishment of a system of records in order to render in good faith the certification required by this clause. The knowledge and information of a participant is not required to exceed that which is normally possessed by a prudent person in the ordinary course of business dealings.
10. Except for transactions authorized under paragraph 8 of these instructions, if a participant in a covered transaction knowingly enters into a lower tier covered transaction with a person who is suspended, debarred, ineligible, or voluntarily excluded from participation in this transaction, in addition to other remedies available to the Federal Government, the department or agency may terminate this transaction for cause or default.

Certification Regarding Debarment, Suspension, Ineligibility and Voluntary Exclusion
Primary Covered Transactions

1. The prospective primary participant certifies to the best of its knowledge and belief that it and its principals:
 - a. Are not presently debarred, suspended, proposed for debarment, declared ineligible, or voluntarily excluded from covered transactions by an Federal department or agency;
 - b. Have not within a three-year period preceding this proposal been convicted of or had a civil judgment rendered against them for commission of fraud or a criminal offense in connection with obtaining, attempting to obtain or performing a public (Federal, State or Local) transaction or contract under a public transaction: violation of Federal or State antitrust statutes or commission of embezzlement, theft, forgery, bribery, falsification or destruction of records, making false statements, or receiving stolen property;
 - c. Are not presently indicted for or otherwise criminally or civilly charged by a governmental entity (Federal, State or local) with commission of any of the offenses enumerated in paragraph (1)(b) of this certification; and
 - d. Have not within a three-period preceding this application/proposal had one or more public transactions (Federal, State or local) terminated for cause or default.
2. Where the prospective primary participant is unable to certify to any of the statements in this certification, such prospective participant shall attach an explanation to this proposal.

EACH PRIME CONTRACTOR SHALL INSERT IN EACH SUBCONTRACT THE CERTIFICATION IN APPENDIX B, AND FURTHER, SHALL REQUIRE ITS INCLUSION IN ANY LOWER TIER SUBCONTRACT, PURCHASE ORDER, OR TRANSACTION THAT MAY IN TURN BE MADE.

Appendix B of 49 CFR Part 29

Certification Regarding Debarment, Suspension, Ineligibility and Voluntary Exclusion--Lower Tier Covered Transactions

This certification applies to subcontractors, material suppliers, vendors and other lower tier participants.

Instructions for Certification

1. By signing and submitting this proposal, the prospective lower tier participant is providing the certification set out below.
2. The certification in this clause is a material representation of fact upon which reliance was placed when this transaction was entered into. If it is later determined that the prospective lower tier participant knowingly rendered an erroneous certification, in addition to other remedies available to the Federal Government, the department or agency with which this transaction originated may pursue available remedies, including suspension and/or debarment.
3. The prospective lower tier participant shall provide immediate written notice to the person to which this proposal is submitted if at any time the prospective lower tier participant learns that its certification was erroneous when submitted or has become erroneous by reason of changed circumstances.
4. The terms "covered transaction," "debarred," "suspended," "ineligible," "lower tier covered transaction," "participant," "person," "primary covered transaction," "principal," "proposal," and "voluntarily excluded," as used in this clause sections of rules implementing Executive Order 12549. You may contact the person to which this proposal is submitted for assistance in obtaining a copy of those regulations.
5. The prospective lower tier participant agrees by submitting this proposal that, should the proposed covered transaction be entered into, it shall not knowingly enter into any lower tier covered transaction with a person who is debarred, suspended, declared ineligible, or voluntarily excluded from participation in this covered transaction, unless authorized by the department or agency with which this transaction originated.
6. The prospective lower tier participant further agrees by submitting this proposal that it will include this clause titled "Certification Regarding Debarment, Suspension, Ineligibility and Voluntary Exclusion--Lower Tier Covered Transaction," without modification, in all lower tier covered transactions and in all solicitations for lower tier covered transactions.
7. A participant in a covered transaction may rely upon a certification of a prospective participant in a lower tier covered transaction that it is not debarred, suspended, ineligible, or voluntarily excluded from the covered transaction, unless it knows that the certification is erroneous. A participant may decide the method and frequency by which it determines the eligibility of its principals. Each participant may, but is not required to, check the Nonprocurement List.
8. Nothing contained in the foregoing shall be construed to require establishment of a system of records in order to render in good faith the certification required by this clause. The knowledge and information of a participant is not required to exceed that which is normally possessed by a prudent person in the ordinary course of business dealings.
9. Except for transactions authorized under paragraph 5 of these instructions, if a participant in a covered transaction knowingly enters into a lower tier covered transaction with a person who is suspended, debarred, ineligible, or voluntarily excluded from participation in this transaction, in addition to other remedies available to the Federal Government, the department or agency with which this transaction originated may pursue available remedies, including suspension and/or debarment.

Certification Regarding Debarment, Suspension, Ineligibility and Voluntary Exclusion **Lower Tier Covered Transactions**

1. The prospective lower tier participant certifies, by submission of this proposal, that neither it nor its principals is presently debarred, suspended, proposed for debarment, declared ineligible, or voluntarily excluded from participation in this transaction by any Federal department or agency.
2. Where the prospective lower tier participant is unable to certify to any of the statements in this certification, such prospective participant shall attach an explanation to this proposal.

Additional Provisions for Construction Contracts Exceeding \$100,000

CONTRACT WORKHOURS AND SAFETY STANDARDS ACT REQUIREMENTS (Title 29 CFR Part 5)

(1) Overtime requirements:

No Contractor or subcontractor contracting for any part of the contract work which may require or involve the employment of laborers, mechanics, watchmen or guards (including apprentices and trainees described in paragraphs 5 and 6 above) shall require or permit any laborer, mechanic, watchman or guard in any workweek in which he/she is employed on such work, to work

in excess of 40 hours in such workweek unless such laborer, mechanic, watchman or guard receives compensation at a rate not less than one and one-half times his/her basic rate of pay for all hours worked in excess of 40 hours in such workweek.

(2) Violations: Liability for Unpaid Wages; Liquidated Damages:

In the event of any violation of the clause set forth in paragraph (1) above, the Contractor and any subcontractor responsible therefore shall be liable for the unpaid wages. In addition, such Contractor and subcontractor shall be liable to the United States (in case of work done under contract for the District of Columbia or a territory, to such District or to such territory), for liquidated damages. Such liquidated damages shall be computed with respect to each individual laborer, mechanic, including watchmen and guards, employed in violation of the clause set forth in paragraph (1) above, in the sum of \$10.00 for each calendar day on which such employee was required or permitted to work in excess of the standard workweek of 40 hours without payment of the overtime wages required by the clause set forth in paragraph (1) above.

(3) Withholding for Unpaid Wages and Liquidated Damages.

The Federal Aviation Administration or the Co-Sponsor shall upon its own action or upon written request of an authorized representative of the Department of Labor withhold or cause to be withheld, from any moneys payable on account of work performed by the Contractor or subcontractor under any such contract or any other Federal contract with the same prime Contractor, or any other Federally-assisted contract subject to the Contract Work Hours and Safety Standards Act, which is held by the same prime Contractor, such sums as may be determined to be necessary to satisfy any liabilities of such Contractor or subcontractor for unpaid wages and liquidated damages as provided in the clause set forth in paragraph (2) above.

(4) Subcontracts.

The Contractor or subcontractor shall insert in any subcontracts the clauses set forth in paragraph (1) through (4) and also a clause requiring the subcontractors to include these clauses in any lower tier subcontracts. The prime Contractor shall be responsible for compliance by any subcontractor or lower tier subcontractor with the clauses set forth in paragraphs (1) through (4) of this section.

(5) Working Conditions.

No Contractor or subcontractor may require any laborer or mechanic employed in the performance of any contract to work in surroundings or under working conditions that are unsanitary, hazardous, or dangerous to his health or safety as determined under construction safety and health standards (29 CFR 1926) issued by Department of Labor.

CLEAN AIR AND WATER POLLUTION CONTROL (Title 49 CFR Part 18.36(i)(12))

In connection with the administration of the Clean Air Act and the Water Pollution Control Act with respect to Federal Grants, specific requirements have been imposed of any contract which is not exempt under the provisions of 40 CFR 15.5.

(1) Any facility listed on the EPA List of Violating Facilities pursuant to Paragraph 15.20 of 40 CFR as of the date of the contract award will not be utilized in the performance of any non-exempt contract or subcontract.

(2) The Contractor shall comply with all the requirements of Section 114 of the Clean Air Act, as amended, 42 USC 1857 et seq. and Section 308 of the Federal Water Pollution Control Act, as amended, 33 USC 1251 et seq. relating to inspection, monitoring, entry, reports and information, as well as all other requirements specified in Section 114 and Section 308 of the Air Act and Water Act, respectively, and all regulations and guidelines issued thereunder after the award of the contract.

(3) Prompt notification shall be required prior to contract award to the awarding official by the Contractor who will receive the award of the receipt of any communication from the Director, Office of Federal Activities, U.S. Environmental Protection Agency, indicating that a facility to be utilized for the contract is under consideration to be listed on the EPA List of Violating Facilities.

(4) The Contractor shall include or cause to be included the criteria and requirements in paragraphs 1 through 4 in any non-exempt subcontract and will take such action as the Government may direct as a means of enforcing such provisions.

ILLINOIS DEPARTMENT OF TRANSPORTATION
DIVISION OF AERONAUTICS

**REQUIRED CONTRACT PROVISIONS FOR
STATE FUNDED AIRPORT CONSTRUCTION PROJECTS**

The following provisions are State of Illinois requirements and are in addition to the REQUIRED CONTRACT PROVISIONS FOR FEDERALLY FUNDED AIRPORT CONSTRUCTION CONTRACTS

DISADVANTAGED BUSINESS POLICY

NOTICE: This proposal contains the special provision entitled "Disadvantaged Business Participation." Inclusion of this Special Provision in this contract satisfies the obligations of the Department of Transportation under federal law as implemented by 49 CFR 23 and under the Illinois "Minority and Female Business Enterprise Act."

POLICY: It is public policy that the businesses defined in 49 CFR Part 23 shall have the maximum opportunity to participate in the performance of contracts financed in whole or in part with State or Federal funds. Consequently, the requirements of 49 CFR Part 23 apply to this contract.

OBLIGATION: The Contractor agrees to ensure that the businesses defined in 49 CFR Part 23 have the maximum opportunity to participate in the performance of this contract. In this regard, the Contractor shall take all necessary and reasonable steps, in accordance with 49 CFR Part 23, to ensure that the said businesses have the maximum opportunity to compete for and perform portions of this contract. The Contractor shall not discriminate on the basis of race, color, national origin, or sex in the selection and retention of subcontractors, including procurement of materials and leases of equipment.

The Contractor shall include the above Policy and Obligation statements of this Special Provision in every subcontract, including procurement of materials and leases of equipment.

DBE/WBE CONTRACTOR FINANCE PROGRAM: On contracts where a loan has been obtained through the DBE/WBE Contractor Finance Program, the Contractor shall cooperate with the Department by making all payments due to the DBE/WBE Contractor by means of a two-payee check payable to the Lender (Bank) and the Borrower (DBE/WBE Contractor).

BREACH OF CONTRACT: Failure to carry out the requirements set forth above and in the Special Provision shall constitute a breach of contract and may result in termination of the contract or liquidated damages as provided in the special provision.

SPECIAL PROVISION FOR DISADVANTAGED BUSINESS ENTERPRISE PARTICIPATION

Revised: August 2, 2011

FEDERAL OBLIGATION: The Department of Transportation, as a recipient of federal financial assistance, is required to take all necessary and reasonable steps to ensure nondiscrimination in the award and administration of contracts. Consequently, the federal regulatory provisions of 49 CFR part 26 apply to this contract concerning the utilization of disadvantaged business enterprises. For the purposes of this Special Provision, a disadvantaged business enterprise (DBE) means a business certified by the Department in accordance with the requirements of 49 CFR part 26 and listed in the Illinois Unified Certification Program (IL UCP) DBE Directory

STATE OBLIGATION. This Special Provision will also be used by the Department to satisfy the requirements of the Business Enterprise for Minorities, Females, and Persons with Disabilities Act, 30 ILCS 575. When this Special Provision is used to satisfy state law requirements on 100 percent state-funded contracts, the federal government has no involvement in such contracts (not a federal-aid contract) and no responsibility to oversee the implementation of this Special Provision by the Department on those contracts. DBE participation on 100 percent state-funded contracts will not be credited toward fulfilling the Department's annual overall DBE goal required by the US Department of Transportation to comply with the federal DBE program requirements.

CONTRACTOR ASSURANCE: The Contractor makes the following assurance and agrees to include the assurance in each subcontract that the Contractor signs with a subcontractor:

The Contractor, subrecipient or subcontractor shall not discriminate on the basis of race, color, national origin, or sex in the performance of this contract. The Contractor shall carry out applicable requirements of 49 CFR part 26 in the award and administration of contracts funded in whole or in part with federal or state funds. Failure by the contractor to carry out these requirements is a material breach of this contract, which may result in the termination of this contract or such other remedy as the recipient deems appropriate.

OVERALL GOAL SET FOR THE DEPARTMENT: As a requirement of compliance with 49 CFR part 26, the Department has set an overall goal for DBE participation in its federally assisted contracts. That goal applies to all federal-aid funds the Department will expend in its federally assisted contracts for the subject reporting fiscal year. The Department is required to make a good faith effort to

achieve the overall goal. The dollar amount paid to all approved DBE companies performing work called for in this contract is eligible to be credited toward fulfillment of the Department's overall goal.

CONTRACT GOAL TO BE ACHIEVED BY THE CONTRACTOR: This contract includes a specific DBE utilization goal established by the Department. The goal has been included because the Department has determined that the work of this contract has subcontracting opportunities that may be suitable for performance by DBE companies. This determination is based on an assessment of the type of work, the location of the work, and the availability of DBE companies to do a part of the work. The assessment indicates that, in the absence of unlawful discrimination, and in an arena of fair and open competition, DBE companies can be expected to perform **7.9%** of the work. This percentage is set as the DBE participation goal for this contract. Consequently, in addition to the other award criteria established for this contract, the Department will only award this contract to a bidder who makes a good faith effort to meet this goal of DBE participation in the performance of the work. A bidder makes a good faith effort for award consideration if either of the following is done in accordance with the procedures set forth in this Special Provision:

- (a) The bidder documents that enough DBE participation has been obtained to meet the goal; or
- (b) The bidder documents that a good faith effort has been made to meet the goal, even though the effort did not succeed in obtaining enough DBE participation to meet the goal.

DBE LOCATOR REFERENCES: Bidders shall consult the IL UCP DBE Directory as a reference source for DBE-certified companies. In addition, the Department maintains a letting and item specific DBE locator information system whereby DBE companies can register their interest in providing quotes on particular bid items advertised for letting. Information concerning DBE companies willing to quote work for particular contracts may be obtained by contacting the Department's Bureau of Small Business Enterprises at telephone number (217)785-4611, or by visiting the Department's web site at www.dot.il.gov.

BIDDING PROCEDURES: Compliance with this Special Provision is a material bidding requirement. The failure of the bidder to comply will render the bid not responsive.

- (a) The bidder shall submit a Disadvantaged Business Utilization Plan on Department forms SBE 2025 and 2026 with the bid.
- (b) The Utilization Plan shall indicate that the bidder either has obtained sufficient DBE participation commitments to meet the contract goal or has not obtained enough DBE participation commitments in spite of a good faith effort to meet the goal. The Utilization Plan shall further provide the name, telephone number and telefax number of a responsible official of the bidder designated for purposes of notification of plan approval or disapproval under the procedures of this Special Provision.
- (c) The Utilization Plan shall include a DBE Participation Commitment Statement, Department form SBE 2025, for each DBE proposed for the performance of work to achieve the contract goal. For bidding purposes, submission of the completed SBE 2025 forms, signed by the DBEs and faxed to the bidder will be acceptable as long as the original is available and provided upon request. All elements of information indicated on the said form shall be provided, including but not limited to the following:
 - (1) The name and address of DBE firms that will participate in the contract;
 - (2) A description, including pay item numbers, of the work each DBE will perform;
 - (3) The dollar amount of the participation of each DBE firm participating. The dollar amount of participation for identified work shall specifically state the quantity, unit price and total subcontract price for the work to be completed by the DBE. If partial pay items are to be performed by the DBE, indicate the portion of each item, a unit price where appropriate and the subcontract price amount;
 - (4) DBE Participation Commitment Statements, form SBE 2025, signed by the bidder and each participating DBE firm documenting the commitment to use the DBE subcontractors whose participation is submitted to meet the contract goal;
 - (5) If the bidder is a joint venture comprised of DBE companies and non-DBE companies, the plan must also include a clear identification of the portion of the work to be performed by the DBE partner(s); and,
 - (6) If the contract goal is not met, evidence of good faith efforts.

GOOD FAITH EFFORT PROCEDURE: The contract will not be awarded until the Utilization Plan submitted by the apparent successful bidder is approved. All information submitted by the bidder must be complete, accurate and adequately document that enough DBE participation has been obtained or document the good faith efforts of the bidder, in the event enough DBE participation has not been obtained, before the Department will commit to the performance of the contract by the bidder. The Utilization Plan will be approved by the Department if the Utilization Plan commits sufficient commercially useful DBE work performance to meet the contract goal or the bidder submits sufficient documentation of a good faith effort to meet the contract goal pursuant to 49 CFR part 26, Appendix A.

The Utilization Plan will not be approved by the Department if the Utilization Plan does not commit sufficient DBE participation to meet the contract goal unless the apparent successful bidder documented in the Utilization Plan that it made a good faith effort to meet the goal. This means that the bidder must show that all necessary and reasonable steps were taken to achieve the contract goal. Necessary and reasonable steps are those which, by their scope, intensity and appropriateness to the objective, could reasonably be

expected to obtain sufficient DBE participation, even if they were not successful. The Department will consider the quality, quantity, and intensity of the kinds of efforts that the bidder has made. Mere *pro forma* efforts, in other words, efforts done as a matter of form, are not good faith efforts; rather, the bidder is expected to have taken genuine efforts that would be reasonably expected of a bidder actively and aggressively trying to obtain DBE participation sufficient to meet the contract goal.

- (a) The following is a list of types of action that the Department will consider as part of the evaluation of the bidder's good faith efforts to obtain participation. These listed factors are not intended to be a mandatory checklist and are not intended to be exhaustive. Other factors or efforts brought to the attention of the Department may be relevant in appropriate cases, and will be considered by the Department.
- (1) Soliciting through all reasonable and available means (e.g. attendance at pre-bid meetings, advertising and/or written notices) the interest of all certified DBE companies that have the capability to perform the work of the contract. The bidder must solicit this interest within sufficient time to allow the DBE companies to respond to the solicitation. The bidder must determine with certainty if the DBE companies are interested by taking appropriate steps to follow up initial solicitations.
 - (2) Selecting portions of the work to be performed by DBE companies in order to increase the likelihood that the DBE goals will be achieved. This includes, where appropriate, breaking out contract work items into economically feasible units to facilitate DBE participation, even when the prime Contractor might otherwise prefer to perform these work items with its own forces.
 - (3) Providing interested DBE companies with adequate information about the plans, specifications, and requirements of the contract in a timely manner to assist them in responding to a solicitation.
 - (4) a. Negotiating in good faith with interested DBE companies. It is the bidder's responsibility to make a portion of the work available to DBE subcontractors and suppliers and to select those portions of the work or material needs consistent with the available DBE subcontractors and suppliers, so as to facilitate DBE participation. Evidence of such negotiation includes the names, addresses, and telephone numbers of DBE companies that were considered; a description of the information provided regarding the plans and specifications for the work selected for subcontracting; and evidence as to why additional agreements could not be reached for DBE companies to perform the work.

b. A bidder using good business judgment would consider a number of factors in negotiating with subcontractors, including DBE subcontractors, and would take a firm's price and capabilities as well as contract goals into consideration. However, the fact that there may be some additional costs involved in finding and using DBE companies is not in itself sufficient reason for a bidder's failure to meet the contract DBE goal, as long as such costs are reasonable.

Also, the ability or desire of a bidder to perform the work of a contract with its own organization does not relieve the bidder of the responsibility to make good faith efforts. Bidders are not, however, required to accept higher quotes from DBE companies if the price difference is excessive or unreasonable.
 - (5) Not rejecting DBE companies as being unqualified without sound reasons based on a thorough investigation of their capabilities. The bidder's standing within its industry, membership in specific groups, organizations, or associations and political or social affiliations (for example union vs. non-union employee status) are not legitimate causes for the rejection or non-solicitation of bids in the bidder's efforts to meet the project goal.
 - (6) Making efforts to assist interested DBE companies in obtaining bonding, lines of credit, or insurance as required by the recipient or Contractor.
 - (7) Making efforts to assist interested DBE companies in obtaining necessary equipment, supplies, materials, or related assistance or services.
 - (8) Effectively using the services of available minority/women community organizations; minority/women contractors' groups; local, state, and federal minority/women business assistance offices; and other organizations as allowed on a case-by-case basis to provide assistance in the recruitment and placement of DBE companies.
- (b) If the Department determines that the apparent successful bidder has made a good faith effort to secure the work commitment of DBE companies to meet the contract goal, the Department will award the contract provided that it is otherwise eligible for award. If the Department determines that the bidder has failed to meet the requirements of this Special Provision and that a good faith effort has not been made, the Department will notify the responsible company official designated in the Utilization Plan that the bid is not responsive. The notification shall include a statement of reasons why good faith efforts have not been found.
- (c) The bidder may request administrative reconsideration of a determination adverse to the bidder within the five working days after receipt of the notification date of the determination by delivering the request to the Department of Transportation, Bureau of Small Business Enterprises, Contract Compliance Section, 2300 South Dirksen Parkway, Room 319, Springfield, Illinois 62764 (Telefax: (217)785-1524). Deposit of the request in the United States mail on or before the fifth business day shall not be deemed delivery. The determination shall become final if a request is not made and delivered. A request may provide additional written documentation and/or argument concerning the issues raised in the determination statement of reasons, provided the documentation and arguments address efforts made prior to submitting the bid. The request will be forwarded to

the Department's Reconsideration Officer. The Reconsideration Officer will extend an opportunity to the bidder to meet in person in order to consider all issues of whether the bidder made a good faith effort to meet the goal. After the review by the Reconsideration Officer, the bidder will be sent a written decision within ten working days after receipt of the request for reconsideration, explaining the basis for finding that the bidder did or did not meet the goal or make adequate good faith efforts to do so. A final decision by the Reconsideration Officer that a good faith effort was made shall approve the Utilization Plan submitted by the bidder and shall clear the contract for award. A final decision that a good faith effort was not made shall render the bid not responsive.

CALCULATING DBE PARTICIPATION. The Utilization Plan values represent work anticipated to be performed and paid for upon satisfactory completion. The Department is only able to count toward the achievement of the overall goal and the contract goal the value of payments made for the work actually performed by DBE companies. In addition, a DBE must perform a commercially useful function on the contract to be counted. A commercially useful function is generally performed when the DBE is responsible for the work and is carrying out its responsibilities by actually performing, managing, and supervising the work involved. The Department and Contractor are governed by the provisions of 49 CFR part 26.55(c) on questions of commercially useful functions as it affects the work. Specific counting guidelines are provided in 49 CFR part 26.55, the provisions of which govern over the summary contained herein.

- (a) DBE as the Contractor: 100 percent goal credit for that portion of the work performed by the DBE's own forces, including the cost of materials and supplies. Work that a DBE subcontracts to a non-DBE does not count toward the DBE goals.
- (b) DBE as a joint venture Contractor: 100 percent goal credit for that portion of the total dollar value of the contract equal to the distinct, clearly defined portion of the work performed by the DBE's own forces.
- (c) DBE as a subcontractor: 100 percent goal credit for the work of the subcontract performed by the DBE's own forces, including the cost of materials and supplies, excluding the purchase of materials and supplies or the lease of equipment by the DBE subcontractor from the prime Contractor or its affiliates. Work that a DBE subcontractor in turn subcontracts to a non-DBE does not count toward the DBE goal.
- (d) DBE as a trucker: 100 percent goal credit for trucking participation provided the DBE is responsible for the management and supervision of the entire trucking operation for which it is responsible. At least one truck owned, operated, licensed, and insured by the DBE must be used on the contract. Credit will be given for the following:
 - (1) The DBE may lease trucks from another DBE firm, including an owner-operator who is certified as a DBE. The DBE who leases trucks from another DBE receives credit for the total value of the transportation services the lessee DBE provides on the contract.
 - (2) The DBE may also lease trucks from a non-DBE firm, including from an owner-operator. The DBE who leases trucks from a non-DBE is entitled to credit only for the fee or commission it receives as a result of the lease arrangement.
- (e) DBE as a material supplier:
 - (1) 60 percent goal credit for the cost of the materials or supplies purchased from a DBE regular dealer.
 - (2) 100 percent goal credit for the cost of materials or supplies obtained from a DBE manufacturer.
 - (3) 100 percent credit for the value of reasonable fees and commissions for the procurement of materials and supplies if not a regular dealer or manufacturer.

CONTRACT COMPLIANCE. Compliance with this Special Provision is an essential part of the contract. The Department is prohibited by federal regulations from crediting the participation of a DBE included in the Utilization Plan toward either the contract goal or the Department's overall goal until the amount to be applied toward the goals has been paid to the DBE. The following administrative procedures and remedies govern the compliance by the Contractor with the contractual obligations established by the Utilization Plan. After approval of the Utilization Plan and award of the contract, the Utilization Plan and individual DBE Participation Statements become part of the contract. If the Contractor did not succeed in obtaining enough DBE participation to achieve the advertised contract goal, and the Utilization Plan was approved and contract awarded based upon a determination of good faith, the total dollar value of DBE work calculated in the approved Utilization Plan as a percentage of the awarded contract value shall become the amended contract goal. All work indicated for performance by an approved DBE shall be performed, managed, and supervised by the DBE executing the Participation Statement.

- (a) **NO AMENDMENT.** No amendment to the Utilization Plan may be made without prior written approval from the Department's Bureau of Small Business Enterprises. All requests for amendment to the Utilization Plan shall be submitted to the Department of Transportation, Bureau of Small Business Enterprises, Contract Compliance Section, 2300 South Dirksen Parkway, Room 319, Springfield, Illinois 62764. Telephone number (217) 785-4611. Telefax number (217) 785-1524.
- (b) **TERMINATION OR REPLACEMENT.** The Contractor shall not terminate or replace a DBE listed on the approved Utilization Plan, or perform with other forces work designated for a listed DBE except as provided in the Special Provision.
- (c) **CHANGES TO WORK.** Any deviation from the DBE condition-of-award or contract plans, specifications, or special provisions must be approved, in writing, by the Department as provided elsewhere in the Contract. The Contractor shall notify affected

DBEs in writing of any changes in the scope of work which result in a reduction in the dollar amount condition-of-award to the contract. Where the revision includes work committed to a new DBE subcontractor, not previously involved in the project, then a Request for Approval of Subcontractor, Department form BC 260A, must be signed and submitted. If the commitment of work is in the form of additional tasks assigned to an existing subcontract, then a new Request for Approval of Subcontractor shall not be required. However, the Contractor must document efforts to assure that the existing DBE subcontractor is capable of performing the additional work and has agreed in writing to the change.

- (d) ALTERNATIVE WORK METHODS. In addition to the above requirements for reductions in the condition of award, additional requirements apply to the two cases of Contractor-initiated work substitution proposals. Where the contract allows alternate work methods which serve to delete or create underruns in condition of award DBE work, and the Contractor selects that alternate method or, where the Contractor proposes a substitute work method or material that serves to diminish or delete work committed to a DBE and replace it with other work, then the Contractor must demonstrate one of the following:
- (1) That the replacement work will be performed by the same DBE (as long as the DBE is certified in the respective item of work) in a modification of the condition of award; or
 - (2) That the DBE is aware that its work will be deleted or will experience underruns and has agreed in writing to the change. If this occurs, the Contractor shall substitute other work of equivalent value to a certified DBE or provide documentation of good faith efforts to do so; or
 - (3) That the DBE is not capable of performing the replacement work or has declined to perform the work at a reasonably competitive price. If this occurs, the Contractor shall substitute other work of equivalent value to a certified DBE or provide documentation of good faith efforts to do so.
- (e) TERMINATION AND REPLACEMENT PROCEDURES. The Contractor shall not terminate or replace a DBE subcontractor listed in the approved Utilization Plan without prior written consent. This includes, but is not limited to, instances in which the Contractor seeks to perform work originally designated for a DBE subcontractor with its own forces or those of an affiliate, a non-DBE firm, or with another DBE firm. Written consent will be granted only if the Bureau of Small Business Enterprises agrees, for reasons stated in its concurrence document, that the Contractor has good cause to terminate or replace the DBE firm. Before transmitting to the Bureau of Small Business Enterprises any request to terminate and/or substitute a DBE subcontractor, the Contractor shall give notice in writing to the DBE subcontractor, with a copy to the Bureau, of its intent to request to terminate and/or substitute, and the reason for the request. The Contractor shall give the DBE five days to respond to the Contractor's notice. The DBE so notified shall advise the Bureau and the Contractor of the reasons, if any, why it objects to the proposed termination of its subcontract and why the Bureau should not approve the Contractor's action. If required in a particular case as a matter of public necessity, the Bureau may provide a response period shorter than five days.

For purposes of this paragraph, good cause includes the following circumstances:

- (1) The listed DBE subcontractor fails or refuses to execute a written contract;
- (2) The listed DBE subcontractor fails or refuses to perform the work of its subcontract in a way consistent with normal industry standards. Provided, however, that good cause does not exist if the failure or refusal of the DBE subcontractor to perform its work on the subcontract results from the bad faith or discriminatory action of the prime contractor;
- (3) The listed DBE subcontractor fails or refuses to meet the prime Contractor's reasonable, nondiscriminatory bond requirements;
- (4) The listed DBE subcontractor becomes bankrupt, insolvent, or exhibits credit unworthiness;
- (5) The listed DBE subcontractor is ineligible to work on public works projects because of suspension and debarment proceedings pursuant to CFR Parts 180, 215 and 1200 or applicable state law;
- (6) You have determined that the listed DBE subcontractor is not a responsible contractor;
- (7) The listed DBE subcontractor voluntarily withdraws from the projects and provides to you written notice of its withdrawal;
- (8) The listed DBE is ineligible to receive DBE credit for the type of work required;
- (9) A DBE owner dies or becomes disabled with the result that the listed DBE contractor is unable to complete its work on the contract;
- (10) Other documented good cause that compels the termination of the DBE subcontractor. Provided, that good cause does not exist if the prime Contractor seeks to terminate a DBE it relied upon to obtain the contract so that the prime Contractor can self-perform the work for which the DBE contractor was engaged or so that the prime Contractor can substitute another DBE or non-DBE contractor after contract award.

When a DBE is terminated, or fails to complete its work on the contract for any reason the Contractor shall make a good faith effort to find another DBE to substitute for the original DBE to perform at least the same amount of work under the contract as the terminated DBE to the extent needed to meet the established contract goal.

- (f) **PAYMENT RECORDS.** The Contractor shall maintain a record of payments for work performed to the DBE participants. The records shall be made available to the Department for inspection upon request. After the performance of the final item of work or delivery of material by a DBE and final payment therefore to the DBE by the Contractor, but not later than thirty calendar days after payment has been made by the Department to the Contractor for such work or material, the Contractor shall submit a DBE Payment Agreement on Department form SBE 2115 to the Regional Engineer. If full and final payment has not been made to the DBE, the DBE Payment Agreement shall indicate whether a disagreement as to the payment required exists between the Contractor and the DBE or if the Contractor believes that the work has not been satisfactorily completed. If the Contractor does not have the full amount of work indicated in the Utilization Plan performed by the DBE companies indicated in the Utilization Plan and after good faith efforts are reviewed, the Department may deduct from contract payments to the Contractor the amount of the goal not achieved as liquidated and ascertained damages. The Contractor may request an administrative reconsideration of any amount deducted as damages pursuant to subsection (h) of this part.
- (g) **ENFORCEMENT.** The Department reserves the right to withhold payment to the Contractor to enforce the provisions of this Special Provision. Final payment shall not be made on the contract until such time as the Contractor submits sufficient documentation demonstrating achievement of the goal in accordance with this Special Provision or after liquidated damages have been determined and collected.
- (h) **RECONSIDERATION.** Notwithstanding any other provision of the contract, including but not limited to Article 50-17 of the Standard Specifications, the Contractor may request administrative reconsideration of a decision to deduct the amount of the goal not achieved as liquidated damages. A request to reconsider shall be delivered to the Contract Compliance Section and shall be handled and considered in the same manner as set forth in paragraph (c) of "Good Faith Effort Procedures" of this Special Provision, except a final decision that a good faith effort was not made during contract performance to achieve the goal agreed to in the Utilization Plan shall be the final administrative decision of the Department.

SPECIAL PROVISION FOR SUBCONTRACTOR MOBILIZATION PAYMENTS

Revised: April 1, 2011

To account for the preparatory work and the operations necessary for the movement of subcontractor personnel, equipment, supplies, and incidentals to the project site and for all other work or operations that must be performed or costs incurred when beginning work approved for subcontracting according to Section 80-01 of the Standard Specifications, the Contractor shall make a mobilization payment to each subcontractor.

This mobilization payment shall be made at least 14 days prior to the subcontractor starting work. The amount paid shall be equal to 3 percent of the amount of the subcontract reported on form AER 260A submitted for the approval of the subcontractor's work.

The mobilization payment to the subcontractor is an advance payment of the reported amount of the subcontract and is not a payment in addition to the amount of the subcontract; therefore, the amount of the advance payment will be deducted from future progress payments.

This provision shall be incorporated directly or by reference into each subcontract approved by the Department

SPECIAL PROVISION FOR PAYMENTS TO SUBCONTRACTORS

Revised: January 1, 2006

Federal regulations found at 49 CFR §26.29 mandate the Department to establish a contract clause to require Contractors to pay subcontractors for satisfactory performance of their subcontracts and to set the time for such payments.

State law also addresses the timing of payments to be made to subcontractors and material suppliers. Section 7 of the Prompt Payment Act, 30 ILCS 540/7, requires that when a Contractor receives any payment from the Department, the Contractor shall make corresponding, proportional payments to each subcontractor and material supplier performing work or supplying material within 15 calendar days after receipt of the Department payment. Section 7 of the Act further provides that interest in the amount of two percent per month, in addition to the payment due, shall be paid to any subcontractor or material supplier by the Contractor if the payment required by the Act is withheld or delayed without reasonable cause. The Act also provides that the time for payment required and the calculation of any interest due applies to transactions between subcontractors and lower-tier subcontractors and material suppliers throughout the contracting chain.

This Special Provision establishes the required federal contract clause, and adopts the 15 calendar day requirement of the State Prompt Payment Act for purposes of compliance with the federal regulation regarding payments to subcontractors. This contract is subject to the following payment obligations.

When progress payments are made to the Contractor according to Article 90-07 of the Standard Specifications, the Contractor shall make a corresponding payment to each subcontractor and material supplier in proportion to the work satisfactorily completed by each subcontractor and for the material supplied to perform any work of the contract. The proportionate amount of partial payment due to

each subcontractor and material supplier throughout the contracting chain shall be determined by the quantities measured or otherwise determined as eligible for payment by the Department and included in the progress payment to the Contractor. Subcontractors and material suppliers shall be paid by the Contractor within 15 calendar days after the receipt of payment from the Department. The Contractor shall not hold retainage from the subcontractors. These obligations shall also apply to any payments made by subcontractors and material suppliers to their subcontractors and material suppliers; and to all payments made to lower tier subcontractors and material suppliers throughout the contracting chain. Any payment or portion of a payment subject to this provision may only be withheld from the subcontractor or material supplier to whom it is due for reasonable cause.

This Special Provision does not create any rights in favor of any subcontractor or material supplier against the State or authorize any cause of action against the State on account of any payment, nonpayment, delayed payment, or interest claimed by application of the State Prompt Payment Act. The Department will not approve any delay or postponement of the 15 day requirement except for reasonable cause shown after notice and hearing pursuant to Section 7(b) of the State Prompt Payment Act. State law creates other and additional remedies available to any subcontractor or material supplier, regardless of tier, who has not been paid for work properly performed or material furnished. These remedies are a lien against public funds set forth in Section 23(c) of the Mechanics Lien Act, 770 ILCS 60/23(c), and a recovery on the Contractor's payment bond according to the Public Construction Bond Act, 30 ILCS 550.

SPECIAL PROVISION FOR ADDITIONAL STATE REQUIREMENTS FOR FEDERAL-AID CONSTRUCTION CONTRACTS

Effective: February 1, 1969

Revised: January 1, 2010

EQUAL EMPLOYMENT OPPORTUNITY

In the event of the Contractor's noncompliance with any provisions of this Equal Employment Opportunity Clause, the Illinois Fair Employment Practices Act or the Fair Employment Practices Commission's Rules and Regulations for Public Contracts, the Contractor may be declared nonresponsible and therefore ineligible for future contracts or subcontracts with the State of Illinois or any of its political subdivisions or municipal corporations, and the contract may be canceled or avoided in whole or in part, and such other sanctions or penalties may be imposed or remedies invoked as provided by statute or regulation.

During the performance of this contract, the Contractor agrees as follows:

- (1) That it will not discriminate against any employee or applicant for employment because of race, color, religion, sex, national origin or ancestry; and further that it will examine all job classifications to determine if minority persons or women are underutilized and will take appropriate affirmative action to rectify any such underutilization.
- (2) That, if it hires additional employees in order to perform this contract or any portion hereof, it will determine the availability (in accordance with the Commission's Rules and Regulations for Public Contracts) of minorities and women in the area(s) from which it may reasonably recruit and it will hire for each job classification for which employees are hired in such a way that minorities and women are not underutilized.
- (3) That, in all solicitations or advertisements for employees placed by it or on its behalf, it will state that all applicants will be afforded equal opportunity without discrimination because of race, color, religion, sex, national origin or ancestry.
- (4) That it will send to each labor organization or representative of workers with which it has or is bound by a collective bargaining or other agreement or understanding, a notice advising such labor organization or representative of the Contractor's obligations under the Illinois Fair Employment Practices Act and the Commission's Rules and Regulations for Public Contracts. If any such labor organization or representative fails or refuses to cooperate with the Contractor in its efforts to comply with such Act and Rules and Regulations, the Contractor will promptly so notify the Illinois Fair Employment Practices Commission and the contracting agency and will recruit employees from other sources when necessary to fulfill its obligations thereunder.
- (5) That it will submit reports as required by the Illinois Fair Employment Practices Commission's Rules and Regulations for Public Contracts, furnish all relevant information as may from time to time be requested by the Commission or the contracting agency, and in all respects comply with the Illinois Fair Employment Practices Act and the Commission's Rules and Regulations for Public Contracts.
- (6) That it will permit access to all relevant books, records, accounts and work sites by personnel of the contracting agency and the Illinois Fair Employment Practices Commission for purposes of investigation to ascertain compliance with the Illinois Fair Employment Practices Act and the Commission's Rules and Regulations for Public Contracts.
- (7) That it will include verbatim or by reference the provisions of paragraphs 1 through 7 of this clause in every performance subcontract as defined in Section 2.10(b) of the Commission's Rules and Regulations for Public Contracts so that such provisions will be binding upon every subcontractor; and that it will also so include the provisions or paragraphs 1, 5, 6 and 7 in every supply subcontract as defined in Section 2.10(a) of the Commission's Rules and Regulations for Public Contracts so that such provisions will be binding upon every such subcontractor. In the same manner as with other provisions of this contract, the Contractor will be liable for compliance with applicable provisions of this clause by all its subcontractors; and further it will promptly notify the contracting agency and the Illinois Fair Employment Practices Commission in the event any subcontractor fails or refuses to comply therewith. In addition, no Contractor will utilize any subcontractor declared by the Commission to be nonresponsible and therefore ineligible for contracts or subcontracts with the State of Illinois or any of its political subdivisions or municipal corporations.

SPECIAL PROVISION FOR NPDES CERTIFICATION

In accordance with the provisions of the Illinois Environmental Protection Act, the Illinois Pollution Control Board Rules and Regulations (35 Ill. Adm. Code, Subtitle C, Chapter I), and the Clean Water Act, and the regulations thereunder, this certification is required for all construction contracts that will result in the disturbance of one or more acres total land area.

The bidder certifies under penalty of law that he/she understands the terms and conditions of the general National Pollutant Discharge Elimination System (NPDES) permit (ILR100000) that authorizes the storm water discharges associated with industrial activity from the construction site identified as part of this certification.

The Airport Owner or its Agent will:

- 1) prepare, sign and submit the Notice of Intent (NOI)
- 2) conduct site inspections and complete and file the inspection reports
- 3) submit Incidence of Non-Compliance (ION) forms
- 4) submit Notice of Termination (NOT) form

Prior to the issuance of the Notice-to-Proceed, for each erosion control measure identified in the Storm Water Pollution Prevention Plan, the contractor or subcontractor responsible for the control measure(s) must sign the above certification (forms to be provided by the Department).

State of Illinois
Department of Transportation

SPECIAL PROVISION
FOR
SECTION 90 MEASUREMENT AND PAYMENT

This Special Provision amends the provisions of the Standard Specifications for Construction of Airports, adopted April 1, 2012 and shall be construed to be a part thereof, superseding any conflicting provisions thereof applicable to the work under the contract.

90-07 PARTIAL PAYMENTS.

DELETE: The entire section.

ADD: Partial payments will be made to the Contractor at least once each month as the work progresses. The payments will be based upon estimates, prepared by the Resident Engineer, of the value of the work performed and materials complete and in place in accordance with the contract, plans, and specifications. Such partial payments may also include the delivered actual cost of those materials stockpiled and stored in accordance with the Section 90-08 PAYMENT FOR MATERIALS ON HAND. From the amount of partial payment so determined, there shall be deducted an amount up to ten percent of the cost of the completed work which shall be retained until all conditions necessary for financial closeout of the project are satisfied. The amount of the estimate approved as due for payment will be vouchered by the Department and presented to the State Comptroller for payment. No amount less than \$1,000.00 will be approved for payment other than the final payment.

It is understood and agreed that the Contractor shall not be entitled to demand or receive partial payment based on quantities of work in excess of those provided in the proposal or covered by approved change orders, except when such excess quantities have been determined by the Engineer to be a part of the final quantity for the item of work in question.

No partial payment shall bind the Department to the acceptance of any materials or work in place as to quality or quantity. All partial payments are subject to correction at the time of final payment as provided in Section 90-09 ACCEPTANCE AND FINAL PAYMENT.

The failure to perform any requirement, obligation, or term of the contract by the Contractor shall be reason for withholding any progress payments until the Department determines that compliance has been achieved. Furthermore, progress payments may be reduced by liens filed pursuant to Section 23(c) of the Mechanics Lien Act, 770 ILCS 60/23(c).

In accordance with 49 USC § 47111, the Department will not make payments totaling more than 90 percent of the contract until all conditions necessary for financial closeout of the project are satisfied.

90-10 TRUST AGREEMENT OPTION.

DELETE: The entire section.

SECTION III

Special Provisions

for

**CONSTRUCT APRON FOR THE FUEL FACILITY;
RELOCATE FUEL FACILITY**

ILLINOIS PROJECT: 3CK-4283

At

LAKE IN THE HILLS AIRPORT
LAKE IN THE HILLS, ILLINOIS

July 8, 2013

Prepared By:

CRAWFORD, MURPHY & TILLY, INC.
CONSULTING ENGINEERS
550 N. COMMONS DRIVE, SUITE 116
AURORA, ILLINOIS 60504
<http://www.cmtengr.com>



Matthew N. Demos
7-8-13
EXPIRES 11/30/13

13255-01-00
13255-02-00

GENERAL

These Special Provisions, together with applicable Standard Specifications, Rules and Regulations, Contract Requirements for Airport Improvement Projects, Payroll Requirements and Minimum Wage Rates which are hereto attached or which by reference are herein incorporated, cover the requirements of the State of Illinois, Department of Transportation, Division of Aeronautics for the construction of the subject project at the Lake in the Hills Airport, Lake in the Hills, Illinois.

GOVERNING SPECIFICATIONS AND RULES AND REGULATIONS

The "Illinois Standard Specifications for Construction of Airports", dated April 1, 2012, State of Illinois Department of Transportation, Division of Aeronautics shall govern the project except as otherwise noted in these Special Provisions. In cases of conflict with any part or parts of said specifications, the said Special Provisions shall take precedence and shall govern. When noted within the Special Provisions, the Illinois Department of Transportation "Standard Specifications for Road and Bridge Construction", Adopted January 1, 2012, shall also apply.

INDEX TO SPECIAL PROVISIONS

<u>ITEM - DESCRIPTION</u>	<u>PAGE NUMBER</u>
DIVISION I – GENERAL PROVISIONS	1
SECTION 40 – Scope of Work	1
SECTION 50 – Control Of Work	2
SECTION 60 – Control Of Materials	3
SECTION 70 – Legal Relations And Responsibility To Public	4
SECTION 80 – Prosecution And Progress	5
SECTION 90 – Measurement And Payment	5
DIVISION II – PAVING CONSTRUCTION DETAILS	6
ITEM 150510 – Engineer's Field Office	6
ITEM 150520 – Mobilization.....	7
ITEM 152 – Excavation And Embankment	8
ITEM 156000 – Erosion Control.....	12
ITEM 209 – Crushed Aggregate Base Course	14
ITEM 401 – Bituminous Surface Course - Superpave (Method I)	16
ITEM 401900 – Remove Bituminous Pavement	17
ITEM 403 – Bituminous Base Course - Superpave (Method I).....	18
ITEM 501 – Portland Cement Concrete Pavement	19
ITEM 602 – Bituminous Prime Coat.....	21
ITEM 603 – Bituminous Tack Coat	22
ITEM 620 – Pavement Marking	23
DIVISION IV – DRAINAGE	24
ITEM 701 – Pipe For Storm Sewers And Culverts.....	24
ITEM 705 – Pipe Underdrains For Airports.....	25
ITEM 751 – Manholes, Catch Basins, Inlets & Inspection Holes.....	26
ITEM 752 – Concrete Culverts, Headwalls and Miscellaneous Drainage Structures.....	27

DIVISION V – TURFING	28
ITEM 901 – Seeding	28
ITEM 908 – Mulching	30
DIVISION VI - LIGHTING INSTALLATION	31
ITEM 106000 ROADWAY LIGHTING	31
ITEM 108 – Installation Of Underground Cable For Airports	34
ITEM 110 – Installation Of Airport Underground Electrical Duct.....	37
ITEM 125 – Installation Of Airport Lighting Systems	39
DIVISION VIII – MISCELLANEOUS	42
ITEM 800 – Remove Fuel Farm.....	42
ITEM 800 – Fuel Farm Tanks	44
ITEM 800 – Credit Card Reader	48
ITEM 800 – Oil Water separator	50
ITEM 910420 – Bollard	52
IDOT DIVISION OF AERONAUTICS POLICY MEMORANDA	A
IDOT DESIGN STANDARDS	B

POLICY MEMORANDA – APPENDIX A INDEX

87-2	DENSITY ACCEPTANCE OF BITUMINOUS PAVEMENTS
87-4	DETERMINATION OF BULK SPECIFIC GRAVITY (d) OF COMPACTED BITUMINOUS MIXES
96-1	ITEM 610, STRUCTURAL PORTLAND CEMENT CONCRETE: JOB MIX FORMULA APPROVAL & PRODUCTION TESTING
96-2	REQUIREMENTS FOR LABORATORY, TESTING, QUALITY CONTROL, AND PAVING OF HMA CONCRETE MIXTURES
96-3	REQUIREMENTS FOR QUALITY ASSURANCE ON PROJECTS WITH BITUMINOUS CONCRETE PAVING
97-2	PAVEMENT MARKING PAINT ACCEPTANCE
2001-1	REQUIREMENTS FOR COLD WEATHER CONCRETING
2003-1	REQUIREMENTS FOR LABORATORY, TESTING, QUALITY CONTROL, AND PAVING OF SUPERPAVE BITUMINOUS CONCRETE MIXTURES FOR AIRPORTS

DIVISION I – GENERAL PROVISIONS

SECTION 40 – SCOPE OF WORK

40-05 MAINTENANCE OF TRAFFIC

ADD:

The Contractor shall be responsible for cleaning and maintaining all haul roads and use a pick-up type sweeper on all pavements and adjacent roadways utilized in hauling operations when material is tracked onto said pavement. **The Contractor shall have a sweeper on site and maintain all pavements clear of dirt and debris at all times or as requested by the Resident Engineer.** If the Contractor fails to comply with the Standard Specifications, Contract Plans or these Special Provisions concerning traffic control, the Resident Engineer shall execute such work as may be deemed necessary to correct deficiencies and the cost thereof shall be deducted from compensation due or which may become due the Contractor under the contract. The Contractor shall be responsible for supplying, maintaining and moving all barricades required for construction. The cost thereof shall not be paid for separately, but shall be considered incidental to the contract unit prices.

The Airport Manager, following consultation with the Resident Engineer, will give proper notice to the nearest Flight Service Station and the Airways Facilities Chief of the Federal Aviation Administration prior to the beginning of construction. The Contractor shall furnish a flagger in radio control with the Air Traffic at any time the active taxiways or airfield pavement are crossed or used for a haul road. The Contractor shall supply his own radios. The cost thereof shall not be paid for separately, but shall be considered incidental to the contract unit prices.

40-09 AIRPORT OPERATIONS DURING CONSTRUCTION

ADD:

a. Construction Activity and Aircraft Movements

For construction activity to be performed in areas other than active operational areas, the storage and parking of equipment and materials, when not in use or about to be installed, shall not encroach upon active operational areas. In protecting operational areas, the minimum clearances maintained for runways shall be in conformance with Part 77 of the Federal Aviation Regulations.

All construction operations shall conform to the plans and in accordance with AC 150/5370-2 (Latest Edition) Operational Safety on Airports During Construction.

b. Limitations On Construction

- (1) Open flame welding or torch cutting operations shall be prohibited, unless adequate fire and safety precautions are provided.
- (2) Open trenches, excavations and stockpiled material near any pavements shall be prominently marked with red flags and lighted by light units during hours of restricted visibility and/or darkness.
- (3) Stockpiled material shall be constrained in a manner to prevent movement resulting from aircraft blast or wind conditions.
- (4) The use of explosives shall be prohibited.

- (5) Burning shall not be allowed.
- c. Debris

Waste and loose material capable of causing damage to aircraft landing gears, propellers, or being ingested in jet engines shall not be placed on active aircraft movement areas. Material tracked on these areas shall be removed continuously during the work project. The Contractor shall provide garbage cans in employee parking areas and storage areas for debris.

SECTION 50 – CONTROL OF WORK

50-10 INSPECTION OF WORK

ADD:

The Contractor shall provide portable flood lighting for nighttime construction. Sufficient units shall be provided so that work areas are illuminated to a level of five horizontal foot candles. The lighting levels shall be calculated and measured in accordance with the current standards of the Illumination Engineering Society. Lights shall be positioned so as not to interfere with Airport operations.

50-12 LOAD RESTRICTIONS

ADD:

Contractor's use of the existing airfield and perimeter pavements by equipment and loaded trucks shall be minimized. **Any damage to existing airfield and perimeter pavements shall be repaired by the Contractor at his own expense to the satisfaction of the Owner. Contractor shall obtain written permission from the Airport Owner to use any airfield pavements.**

50-18 PLANS AND WORK DRAWINGS

DELETE:

References to "approval" in first paragraph and replace with "review".

REVISE the fifth paragraph to read:

Shop drawings submitted by the Contractor for materials and/or equipment to be provided as a part of the contract shall be reviewed by the Project Engineer for substantial conformance of said materials and/or equipment, to contract requirements. Shop drawings shall be fully descriptive, complete and of sufficient detail for ready determination of compliance.

REVISE the last paragraph to read:

The following information shall be clearly marked on each shop, working, and layout drawing, catalog cut, pamphlet specifications sheet, etc., submitted.

PROJECT LOCATION: Lake in the Hills Airport

PROJECT TITLE: Construct Apron for the Fuel Facility;
Relocate Fuel Facility

PROJECT NUMBERS: IL Project: 3CK-4283

CONTRACT ITEM: (i.e. AR 156520 Inlet Protection)

SUBMITTED BY: (Contractor/Subcontractor Name)

DATE: (Date Submitted)

SECTION 60 – CONTROL OF MATERIALS

60-01 SOURCE OF SUPPLY AND QUALITY REQUIREMENTS

ADD: After the last paragraph

The Contractor shall certify all materials contained in the contract. Certification documentation shall be submitted to the Engineer. It shall be the sole responsibility of the Contractor to ensure the delivery of adequate and accurate documentation prior to the delivery of the materials.

If, upon delivery and incorporation of any materials, the Contractor has failed to provide the necessary submittals as required by Sections 50-18, 60-01, 60-03 and 60-11 of the Standard Specifications and Special Provisions, the pay item shall not be included on the Construction Progress Payment report until such submittals have been furnished.

60-03 CERTIFICATION OF COMPLIANCE

ADD:

Additional requirements are specified in Section 60-11 Certification of Materials.

60-11 CERTIFICATION OF MATERIALS

ADD:

The Contractor shall certify all materials incorporated into the contract. Certification documentation shall be submitted to the Resident Engineer. It shall be the **sole** responsibility of the Contractor to ensure the submittal of adequate and accurate documentation in order to satisfy the contract material certification requirements **prior** to the delivery of the materials. Materials without certification or those with certification that demonstrates the materials do not meet the requirements of the plans and specifications shall be considered nonconforming and subject to the provisions of Section 50-02.

As a guide to the certification process and requirements, the Contractor shall use the Illinois Department of Transportation/Division of Aeronautics MANUAL FOR DOCUMENTATION OF AIRPORT MATERIALS dated April 1, 2010 or latest edition including any addendums. Copies of this manual are available by contacting Mr. Mike Wilhelm-Division of Aeronautics at (217) 785-4282 or from their website at <http://www.dot.state.il.us/aero/aviamanual.html>.

The cost of providing the required material documentation and certifications shall **not** be paid for separately, but shall be considered incidental to the associated item.

SECTION 70 – LEGAL RELATIONS AND RESPONSIBILITY TO PUBLIC

70-17 CONTRACTOR'S RESPONSIBILITY FOR UTILITY SERVICE AND FACILITIES OF OTHERS

ADD:

Special care shall be taken on all operations and particularly near pavement edges to avoid damage to edge lights and all underground electrical cable on the airport. The approximate location of existing underground cable is shown on drawings. Any airfield lights or cable that are broken and require replacement because of the Contractor's operations will be replaced by the contractor at his own expense.

Any airfield cable repairs or replacement to any part of the electrical system made necessary by the Contractor's operations will be made by him in the manner specified in Sections 108 and 125 at no cost to the airport. Cost of replacement to be borne by the Contractor shall include any expense incurred in locating as well as repairing or replacing damaged parts of the system by the owning agency.

It shall be the Contractor's responsibility to locate and protect all airport-owned utilities within the construction limits. This includes all electrical cables, storm sewer, drain tile, sanitary sewer and water main.

Special attention is necessary when working near FAA power and control cables. Any FAA utility that is damaged or cut during construction shall be repaired immediately. FAA requires that any damaged cable be replaced in its entirety, from power/control source to the equipment/service. Splices of any kind will not be permitted. Exposures of any FAA cables must be done by hand digging or hydro-excavation. No additional compensation will be made for locating, replacement or repair of FAA facilities or cables but, shall be incidental to the contract.

When FAA cables are required to be located, or the contractor is planning on working on or around FAA cables, conduits or equipment, a 3 working day (72 hour) advanced notice shall be given to the FAA before any such markings are required. Once FAA marks the cables, the contractor will be required to survey the FAA utilities so they can be replaced during construction without remarking by the FAA. This shall be incidental to the contract. The FAA personnel are only available from 9 am to 3 pm, Monday through Friday with advanced notice.

Should any utilities or cables require location, the following people shall be contacted:

LAKE IN THE HILLS AIRPORT

<u>Utility Service or Facility</u>	<u>Contact (Person)</u>	<u>Contact (Phone)</u>
AT&T – Telephone Cables	J.U.L.I.E. (Joint Utility Locating Information for Excavators)	1-800-892-0123
ComEd - Electric Cables	J.U.L.I.E. (Joint Utility Locating Information for Excavators)	1-800-892-0123
NICOR - Gas Lines	J.U.L.I.E. (Joint Utility Locating Information for Excavators)	1-800-892-0123
FAA Control and Communication Cables	FAA Sector Office	TBD

SECTION 80 – PROSECUTION AND PROGRESS

80-03 NOTICE TO PROCEED

ADD:

The Notice to Proceed will not be given until all materials are certified by the Contractor to be available and on hand and meeting the Buy American requirements per the Contract Documents.

80-05 LIMITATION OF OPERATIONS

ADD:

The Contractor shall not have access to any part of the active airfield (aprons, runways or taxiways) for any equipment or personnel without approval of the Airport Manager.

80-07 TEMPORARY SUSPENSION OF THE WORK

REVISE the second paragraph to read:

In the event that the Contractor is ordered by the Engineer to suspend work for some unforeseen cause not otherwise provided for in the contract and over which the Contractor has no control, the Contractor may be reimbursed for actual money expended on the work during the period of shutdown. No allowance will be made for anticipated profits. The period of shutdown shall be computed from the effective date of the Engineer's order to suspend work to the effective date of the Engineer's order to resume the work. Claims for such compensation shall be filed with the Resident Engineer within the time period stated in the Engineer's order to resume work. The Contractor shall submit with his/her claim information substantiating the amount shown on the claim. The Resident Engineer will forward the Contractor's claim to the Division for the consideration in accordance with local laws or ordinances. No provision of this article shall be construed as entitling the Contractor to compensation for delays due to inclement weather, for suspension made at the request of the Engineer, or for any other delay provided for in the contract, plans, or specifications.

SECTION 90 – MEASUREMENT AND PAYMENT

90-05 PAYMENT FOR EXTRA AND FORCE ACCOUNT WORK

ADD the following to subsection B.7. Statements:

All statements of the cost of force account work shall be furnished to the Engineer not later than 60 days after completion of the force account work. If the statement is not received within the specified time frame, all demands for payment for the extra work are waived and the Division, Airport Owner and Local Sponsor are released from any and all such demands. It is the responsibility of the Contractor to ensure that all statements are received within the specified time regardless of the manner or method of delivery.

DIVISION II – PAVING CONSTRUCTION DETAILS

ITEM 150510 – ENGINEER'S FIELD OFFICE

150-2.1

REVISE:

Paragraph (G) to the following:

- (G) One (1) electric water cooler dispenser capable of dispensing cold and hot water and a supply of water bottles as needed.

Paragraph (I) to the following:

- (I) One (1) dry process copy machine (including maintenance and operating supplies) capable of both collating and reproducing prints up to a half size (11"X 17") and capable of copying field books.

ADD:

- (N) One first-aid cabinet fully equipped.
- (O) One (1) 800 Watt, 0.8 cubic foot microwave oven.
- (P) One (1) Coffee Maker
- (Q) Solid waste disposal consisting of two (2) 28-quart waste baskets and an outside trash container of sufficient size to accommodate a weekly provided pick-up service.
- (R) One (1) internet access account for use by the Engineer with a minimum advertised download speed of up to 768 Kbps and a minimum advertised upload speed of up to 384 Kbps. The type of internet access chosen by the Contractor shall allow for simultaneous use of the internet connection, landline telephone, and facsimile machine. Any required modems, broadband cards or other equipment needed for connecting a desktop or laptop computer to the type of internet connection selected by the Contractor shall also be provided by the Contractor.

BASIS OF PAYMENT

150-3.1

DELETE the second sentence of the second paragraph of this section.

Payment will be made under:

ITEM AR150510 ENGINEER'S FIELD OFFICE – PER LUMP SUM.

ITEM 150520 – MOBILIZATION

BASIS OF PAYMENT

150-3.1

ADD:

Payment will be made under:

ITEM AR150520 MOBILIZATION – PER LUMP SUM.

ITEM 152 – EXCAVATION AND EMBANKMENT

DESCRIPTION

152-1.1

ADD:

All excess excavation material shall be hauled offsite at no additional cost to the contract.

Compaction control tests shall be in accordance with ASTM D698 (Standard Proctor) for aircraft weights of less than 60,000.

152-1.2 CLASSIFICATION

DELETE the second, third and fourth paragraphs.

ADD:

Offsite Borrow Excavation shall consist of excavating suitable materials obtained from offsite locations approved by the Resident Engineer and transporting the materials to various locations throughout the Contract construction limits for topsoil placement, shoulder fill, and embankment. The offsite borrow material shall meet the requirements of Article 204.02 of the IDOT "Standard Specifications for Road and Bridge Construction", latest edition.

152-1.3 CLEAN CONSTRUCTION OR DEMOLITION DEBRIS

PROJECT CONDITIONS

- A. Prior to bidding, the bidder shall make a site visit to become familiar with the current conditions. He shall also determine the accessibility and assess safety measures that will be necessary to perform the contract work.
- B. Material Sampling and Analysis:
 - 1. The Contractor shall provide his own sampling and analysis as required, and in compliance with applicable laws, prior to offsite disposal of all materials. This costs shall be borne by the Contractor at no additional expense to the Owner

REGULATORY REQUIREMENTS

- A. The Contractor shall comply with all applicable local, state and federal laws and regulations with regard to material removal, handling and disposal, and shall pay all assessed costs and fees.
- B. The Contractor shall comply with the Illinois Environmental Protection Act, as amended by Public Act 096-1416 that was signed in to law on July 30, 2010, Public Act 097-0137 that was signed in to law on July 14, 2011, and all applicable amendments of the Illinois Environmental Protection Act.

SUBMITTALS

- A. Contractor shall submit a Construction or Demolition Debris (CCDD) & Soil Removal and Disposal Plan to the Engineer. Submit the following as a minimum:
 - 1. A list of all construction or demolition debris anticipated to be generated requiring disposal.

2. The anticipated quantity (both in tons and in cubic yards) of construction or demolition debris to be disposed of and identification of disposal facility including address and contact information.
3. The anticipated quantity (both in tons and in cubic yards) of surplus soil to be disposed of, and identification of disposal facility including address and contact information.

If further CCDD testing is deemed necessary by the Contractor and/or by the Contractor's chosen disposal facility, as a minimum, the Contractor shall submit the following:

1. Proposed Testing Program to establish that the surplus soil is uncontaminated, for compliance with the requirements of the Illinois Environmental Protection Act. Include details of intended testing program, and rate of sampling (number of samples based on total quantity of surplus soil generated).
2. Credentials of the testing Lab that will perform the testing, and credentials of the Illinois Licensed Professional Engineer or Illinois Licensed Professional Geologist that will complete all required certification forms.
3. Results of the Proposed Testing Program.

GENERAL

- A. The following work shall be included:
 1. Removal, handling and legal offsite disposal of all construction or demolition debris generated from all contract work, considering it to be clean construction or demolition debris (CCDD).
 2. Removal, handling and legal offsite disposal of surplus soil generated from all contract work, considering it to be uncontaminated.
 3. Debris and surplus soil disposal shall include any onsite drying of the material as required, so that the material will pass the paint-filter test as per Method 9095B in USEPA's publication SW 846, prior to transportation.
 4. Any costs and fees for legally-permitted-facilities accepting clean construction or demolition debris (CCDD), and/or uncontaminated surplus soil.
 5. Additional sampling and testing of surplus soil to establish that it is uncontaminated, and certification to that effect by an Illinois Licensed Professional Engineer or an Illinois Licensed Professional Geologist using Form LPC-663, both as required by law and as required by the site accepting the material.
 6. Any other applicable work, costs and fees as required by local, state and federal laws.

MATERIAL CHARACTERIZATION FOR OFFSITE DISPOSAL

- A. Costs for any and all additional testing, sampling, laboratory analysis or any other document that is required by the recipient of the material (disposal site) to establish that the material is uncontaminated, shall be borne by the Contractor at no additional expense to the Owner.

CONSTRUCTION METHODS

152-2.2 EXCAVATION

ADD: The 9th paragraph of this section to read:

In cut areas, not requiring porous granular embankment, the top 8" of subgrade shall be compacted to a density of not less than the percentage of the maximum dry density, at optimum moisture, shown in

Table 1 as determined by the compaction control tests cited in Division VII for ASTM D698 (Standard Proctor) for aircraft weights of less than 60,000 pounds. In cut areas, where abandoned utilities, including duct bank, gas pipe lines, fuel lines, water mains and sewer pipe are encountered, the utilities shall be removed. The cost of removal shall be considered incidental unless it is specifically called out for removal on the plan sheets.

152-2.2 BORROW EXCAVATION

ADD:

Offsite Borrow Excavation shall consist of excavating suitable materials obtained from offsite locations approved by the Resident Engineer and transporting the materials to various locations throughout the Contract construction limits for topsoil placement, shoulder fill, and embankment. The offsite borrow material shall meet the requirements of Article 204.02 of the IDOT "Standard Specifications for Road and Bridge Construction", latest edition. Formation and compaction of embankment shall be completed as required elsewhere in Item 152 of the Standard Specifications.

152-2.15 DUST CONTROL WATERING

ADD:

This work shall consist exclusively of the control of dust resulting from construction operations and is not intended for use in the compaction of earth embankment.

Dust shall be controlled by the uniform application of sprinkled water and shall be applied as directed by the Resident Engineer, in a manner meeting his approval.

Dust control watering shall not be paid for separately, but shall be considered incidental to the contract.

METHOD OF MEASUREMENT

152-3.3

DELETE: This section.

152-3.4

ADD:

Offsite Borrow Excavation shall be the number of cubic yards of placed material measured in its final position in the excavation or embankment construction areas, and pay quantities shall be computed by the method of average end areas. No separate measurement of material shrinkage shall be made, and the Contractor shall account for such shrinkage in his Contract unit price for Offsite Borrow Excavation.

BASIS OF PAYMENT

152-4.1

DELETE: This section.

152-4.2

DELETE: This section.

152-4.3

DELETE: This section.

152-4.4

DELETE: This section.

152-4.5

ADD:

Payment will be made at the contract unit price per cubic yard measured in initial position for "Unclassified Excavation". This price shall be full compensation for furnishing all materials, and for labor, equipment, tools and incidentals necessary to satisfactorily complete the item. Topsoil stripping, topsoil placement, shoulder fill, embankment fill and excess material disposal shall not be paid for separately, but shall be included in the unit bid price for "UNCLASSIFIED EXCAVATION.

Clean Construction or Demolition Debris (CCDD) removal and disposal, topsoil placement, shoulder fill and embankment fill shall not be paid for separately, but shall be included in the unit bid price for "Unclassified Excavation".

Payment will be made under:

ITEM AR152410	UNCLASSIFIED EXCAVATION – PER CUBIC YARD.
ITEM AR152442	OFFSITE BORROW EXCAVATION – PER CUBIC YARD.

ITEM 156000 – EROSION CONTROL

MATERIALS

156-2.4 TEMPORARY MULCH

ADD:

Temporary mulch shall be light-duty hydraulic mulch.

CONSTRUCTION METHODS

156-3.7 INLET PROTECTION

ADD:

Inlet filter sediment traps shall be placed in all proposed and existing inlets and catch basins as shown on the plans or as directed by the Resident Engineer.

156-3.8

ADD:

In the event that temporary erosion and pollution control measures are ordered by the Engineer due to the Contractor's negligence or carelessness, the work shall be performed by the Contractor at no additional cost to the Owner.

METHOD OF MEASUREMENT

156-4.2

DELETE: This section.

156-4.3

REVISE: This section to read:

Temporary Seeding and Temporary Mulching shall not be measured for payment, but shall be considered incidental to the contract.

156-4.4

DELETE: This section.

BASIS OF PAYMENT

156-5.1

REVISE: This section to read:

Payment will be made at the contract unit price per linear foot of Silt Fence and at the contract unit price per each for Inlet Protection. This price shall be full compensation for furnishing all materials for all preparation and installation of these materials, including excavation, placement, tie-down stakes, staples, maintenance and removal and for all labor, equipment, tools, and incidentals necessary to complete this item.

Temporary seeding and temporary mulching shall not be measured for payment. It shall be considered incidental to the contract.

Payment will be made under:

ITEM AR156510	SILT FENCE – PER LINEAR FOOT.
ITEM AR156520	INLET PROTECTION – PER EACH.

ITEM 209 – CRUSHED AGGREGATE BASE COURSE

MATERIALS

209-2.1 CRUSHED COARSE AGGREGATE

DELETE: Gradation "C" in Table 1.

CONSTRUCTION METHODS

209-3.4 FINISHING AND COMPACTING

ADD:

The new crushed aggregate base course shall be compacted to not less than 100% of maximum density at optimum moisture as determined by compaction control tests specified in Division VII for aircraft with gross weights of 60,000 lbs and less (Standard Proctor ASTM D698).

The Contractor shall submit copies of all density test results for each lift to the Resident Engineer prior to acceptance testing.

DELETE: Second sentence, third paragraph and REPLACE with:

When the rolling develops irregularities that exceed 3/8 inch when tested using an acceptable method, the irregular surface shall be loosened, refilled with the same kind of material as that used in constructing the course, and rolled again as required.

209-3.7 SURFACE GRADE ACCURACY

REVISE: The first sentence to read as follows:

After the course has been compacted, the surface shall be checked for accuracy of grade and crown and shall not vary by more than 3/8 inch from the surface elevations shown on the plans or authorized by the Engineer.

METHOD OF MEASUREMENT

209-4.1

DELETE: This Entire Section.

209-4.2

DELETE: This Entire Section.

ADD:

The Crushed Aggregate Base Course – 8" and Crushed Aggregate Base Course – 12" will be measured by the square yard of the thickness specified in place, completed and accepted. The Contractor shall furnish approved duplicate load tickets upon which is recorded the net weight of the aggregates in each truck. The Contractor shall submit one (1) load ticket to the Resident Engineer, or his/her duly authorized representative, at the job site when the truck load is incorporated into the base.

209-4.3

DELETE: This Entire Section.

BASIS OF PAYMENT

209-5.1

DELETE: Entire Section.

ADD:

Payment shall be made at the contract unit price per square yard for Crushed Aggregate Base Course – 8” and Crushed Aggregate Base Course – 12”. This price shall be full compensation for furnishing all materials and for all preparation, hauling, and placing of these materials, and for all labor, equipment, tools and incidentals necessary to complete the item.

Payment will be made under:

ITEM AR209608 CRUSHED AGG. BASE COURSE – 8” – PER SQUARE YARD.
ITEM AR209612 CRUSHED AGG. BASE COURSE – 12” – PER SQUARE YARD.

ITEM 401 – BITUMINOUS SURFACE COURSE - SUPERPAVE (METHOD I)

(Central Plant Hot Mix)

COMPOSITION

401-3.2 JOB MIX FORMULA

ADD: The following after the third paragraph of this section:

Table 1 Superpave Design Criteria for Aircraft under 60,000 pounds (Runway or Taxiway) shall apply.

CONSTRUCTION METHODS

401-4.12 JOINTS

ADD: The following as the sixth paragraph of this section:

If at any time during the surface course paving operation, it becomes necessary to end a paving lane at a location other than the new finished pavement edge because of ending a day's paving, machinery breakdown, etc., the lane end will be sawed back a sufficient distance to provide a smooth, neat appearing joint from which to resume paving. The sawed face will be painted with a tack coat and this work shall be considered incidental to Item 401, Bituminous Surface Course, and no additional compensation will be allowed.

401-4.14 SHAPING EDGES

ADD: The following as the second paragraph for this section:

All pavement edges, including the pavement ends, must be left in proper alignment, as shown on the plans. This may be accomplished by a trimming method, or, at the Contractor's option, by sawing after the paving has been completed. No additional compensation will be made if the sawing method is used.

401-4.15 ACCEPTANCE TESTING OF HMA MIXES FOR DENSITY

DELETE: All references to Method II for quantities over 2,500 tons.

BASIS OF PAYMENT

401-6.1

Payment will be made under:

ITEM AR401610 BITUMINOUS SURFACE COURSE – PER TON.

ITEM 401900 – REMOVE BITUMINOUS PAVEMENT

DESCRIPTION

401-1.1

ADD: To the second sentence.

The type of material to be removed along with approximate typical pavement section is shown on the plans. Pavement structure information was taken from airport records, data supplied by airport personnel and soil borings. The Contractor shall verify the type and thickness of material to be removed. **No extra compensation will be allowed for any variations in the pavement sections actually encountered.**

CONSTRUCTION METHODS

401-2.1

ADD:

Any damage to the pavement beyond the limits as shown on the plans shall be removed and replaced by the Contractor at his expense. These areas shall be saw cut to a uniform width.

METHOD OF MEASUREMENT

401-3.1

DELETE: This section.

ADD:

Pavement removal shall not be measured for payment, but will be considered incidental to the Contract unit price of REMOVE FUEL FARM (for removals in existing fuel facility area) and the new bituminous pavement items (for removals in the new apron pavement area).

BASIS OF PAYMENT

401-5.1

DELETE: This section.

ADD:

No direct payment will be made for pavement removal, as this item will be considered incidental to the Contract unit price for REMOVE FUEL FARM and new bituminous pavement items.

ITEM 403 – BITUMINOUS BASE COURSE - SUPERPAVE (METHOD I)

(Central Plant Hot Mix)

COMPOSITION

403-3.2 JOB MIX FORMULA

ADD: The following after the third paragraph of this section:

Table 1 Superpave Design Criteria for Aircraft under 60,000 pounds (Runway or Taxiway) shall apply.

CONSTRUCTION METHODS

403-4.11 JOINTS

ADD: The following paragraph to this section:

At any time during the base course paving operation it becomes necessary to end a paving lane at a location other than the proposed finished pavement edge because of ending a day's paving, machinery breakdown, etc.; the lane end will be sawed back a sufficient distance to provide a smooth, neat appearing joint from which to resume paving. The sawed face will be painted with a tack coat and this work shall be considered incidental to Item 403 Bituminous Base Course, and no additional compensation will be allowed.

403-4.12 SHAPING EDGES

ADD:

All pavement edges, including the pavement ends, must be left in proper alignment as shown on the plans. This may be accomplished by a trimming method or at the Contractor's option by sawing after the paving has been completed. No additional compensation will be made if the sawing method is used.

401-4.13 ACCEPTANCE TESTING OF HMA MIXES FOR DENSITY

DELETE: All references to Method II for quantities over 2,500 tons.

BASIS OF PAYMENT

403-6.1

Payment will be made under:

ITEM AR403610 BITUMINOUS BASE COURSE – PER TON.

ITEM 501 – PORTLAND CEMENT CONCRETE PAVEMENT

DESCRIPTION

501-1.1

DELETE: Entire Section

ADD:

This work shall consist of pavement composed of Portland Cement concrete (PCC) reinforced with welded steel wire fabric, including 6" monolithic concrete curb, constructed on a prepared aggregate base course in accordance with these specifications and shall conform to the lines, grades, thickness, typical sections and details on the plans.

MATERIALS

501-2.1

DELETE: Entire Section

ADD:

All material, including cement, aggregates, water, admixtures and steel reinforcement will meet the requirements of Item 610 of these specifications.

Curing materials shall be liquid membrane-forming compounds conforming to the requirements of ASTM C-309, Type 2 (White Pigmented).

CONSTRUCTION METHODS

501-3.1

DELETE: Entire Section

ADD:

Constructions methods will meet the requirements of Item 610 of these specifications, and as specified herein.

ADD:

The surface texture shall be broom finished when the water sheen has practically disappeared. The equipment shall operate across the pavement surface, providing corrugations that are uniform in appearance and approximately 1/16 of an inch in depth. It is important that the texturing equipment not tear or unduly roughen the pavement surface during the operation. Any imperfections resulting from the texturing operation shall be corrected.

METHOD OF MEASUREMENT

501-4.1

ADD:

Monolithic concrete barrier curb and all steel reinforcement will not be measured separately for payment, but will be included in the contract unit price of the PCC pavement.

BASIS OF PAYMENT

501-5.1 GENERAL

DELETE: Entire section.

ADD:

The quantity of PCC pavement measured as outlined in Section 501-4.1 will be full compensation for furnishing and placing all materials, tools, equipment, concrete pavement, 6" monolithic barrier curb, steel reinforcement, jointing, texturing, curing and all other incidentals as shown in the plans and as specified herein.

The contract unit price will also include payment for all quality control engineering and field test specimen preparation and strength determination.

Payment will be made under:

ITEM AR501508 8" PCC PAVEMENT – PER SQUARE YARD.

ITEM 602 – BITUMINOUS PRIME COAT

CONSTRUCTION METHODS

602-3.3 APPLICATION OF BITUMINOUS MATERIAL

ADD: The following to the second paragraph:

Areas worn from hauling operations shall be re-primed at no additional cost to the Contract.

BASIS OF PAYMENT

602-5.1

ADD:

Payment will be made under:

ITEM AR602510 BITUMINOUS PRIME COAT – PER GALLON.

ITEM 603 – BITUMINOUS TACK COAT

CONSTRUCTION METHODS

603-3.3 APPLICATION OF BITUMINOUS MATERIAL

ADD: The following to the second paragraph:

Areas worn from hauling operations shall be re-tacked at no additional cost to the Contract.

BASIS OF PAYMENT

603-5.1

ADD:

Payment will be made under:

ITEM AR603510 BITUMINOUS TACK COAT – PER GALLON.

ITEM 620 – PAVEMENT MARKING

MATERIALS

620-2.2 PAINT

ADD:

All paint shall be waterborne.

The paint shall contain no lead, chromium, cadmium or barium.

CONSTRUCTION METHODS

620-3.3 PREPARATION OF SURFACE

ADD:

Existing marking that is to be re-painted shall be cleaned using sand blasting or high pressure water or other methods as approved by the Engineer to remove dirt, grease, laitance, loose or flaking paint and any paint that is not bonding at no additional cost to the contract.

620-3.9 CLEAN UP

ADD:

The Contractor shall remove from the work area all debris, waste, loose or un-adhered reflective media, and by-products generated by the surface preparation and application operations to the satisfaction of the Resident Engineer. The Contractor shall dispose of these wastes in strict compliance with all applicable state, local and federal environmental statutes and regulations.

METHOD OF MEASUREMENT

620-4.1

ADD:

The quantity of permanent markings to be paid for shall be the number of square feet of painting with the specified material **measured only once to apply two coats** in conformance with the specifications and accepted by the Engineer. Quantities will not be distinguished between different colors of paint.

BASIS OF PAYMENT

ADD:

Payment will be made under:

ITEM AR620520 PAVEMENT MARKING – WATERBORNE – PER SQUARE FOOT.

DIVISION IV – DRAINAGE

ITEM 701 – PIPE FOR STORM SEWERS AND CULVERTS

MATERIALS

701-2.1 GENERAL

DELETE: Entire Section.

ADD:

Pipe shall be of the type and diameter indicated and installed at the locations shown on the plans. Pipe for storm sewers shall be concrete storm sewer pipe Class IV reinforced concrete conforming to ASTM C-76 (with joints meeting ASTM C-361) as called out in the plans.

BASIS OF PAYMENT

701-5.1

ADD:

Payment will be made under:

ITEM AR701512 12” RCP, CLASS IV – PER LINEAR FOOT.

ITEM 705 – PIPE UNDERDRAINS FOR AIRPORTS

CONSTRUCTION METHODS

705-3.6 BACKFILLING

ADD:

Backfilling material for voids left by underdrain removal under proposed pavement areas shall consist of IDOT CA-6 material compacted to 95% of the maximum density in accordance with ASTM D698 (Standard Proctor). This cost shall be considered incidental to the associated pay item.

705-3.10 UNDERDRAIN REMOVAL

ADD:

This work shall consist of removal of existing underdrain pipes of various types and sizes. Trenches resulting from underdrain removal shall be backfilled and compacted in accordance with Section 701-3.5 for areas under proposed pavements. Pipe removed shall be disposed of off airport property.

METHOD OF MEASUREMENT

705-4.1

ADD as the last sentence of the first paragraph:

The footage of underdrain removal to be paid for shall be the number of linear feet of underdrain satisfactorily removed and disposed of off airport property, measured along the centerline of the pipe from removal limits.

BASIS OF PAYMENT

705-5.1

DELETE the fourth paragraph and REPLACE with:

The contract unit price per linear foot for underdrain pipe removal and per each for underdrain end section removal shall be full payment for furnishing all materials, and for all excavation, earth backfill, select granular backfill placement, compaction, and for all labor, equipment and tools necessary to complete this item to the satisfaction of the Engineer.

Payment will be made under:

ITEM AR705900 REMOVE UNDERDRAIN – PER LINEAR FOOT.
ITEM AR705902 REMOVE UNDERDRAIN END SECTION – PER EACH.

ITEM 751 – MANHOLES, CATCH BASINS, INLETS & INSPECTION HOLES

DESCRIPTION

751-1.1

ADD:

Specifically, this item consists of the construction of inlets and manholes as shown on the plans or as directed by the Engineer.

Type A Inlets shall conform to IDOT Standard 602301-03.

Type A manholes with four (4) and five (5) foot diameters shall conform to IDOT Standard 602401-03.

Type 1 frames and grates (open and closed lids) shall conform to IDOT Standard 604001-03.

Type 8 grates shall conform to IDOT Standard 604036-02

CONSTRUCTION METHODS

751-3.1 UNCLASSIFIED EXCAVATION

ADD:

(f) DEWATERING – The Contractor shall, at all times, provide and maintain in operation pumping and/or well point equipment for the complete dewatering of the excavation. No structure shall be permitted to be constructed in an excavated area in which any amount of water flows or is pooled.

BASIS OF PAYMENT

751-5.1

ADD:

Payment will be made under:

ITEM AR751411	INLET-TYPE A – PER EACH.
ITEM AR751540	MANHOLE 4' – PER EACH.
ITEM AR751550	MANHOLE 5' – PER EACH.

**ITEM 752 – CONCRETE CULVERTS, HEADWALLS AND MISCELLANEOUS
DRAINAGE STRUCTURES**

DESCRIPTION

752-1.1

ADD:

Precast reinforced concrete flared end sections shall be in conformance with IDOT Standard 542301-03. Grating for the flared end section shall conform to IDOT Standard 542311-03 (modified for 12" pipe).

BASIS OF PAYMENT

752-5.1

ADD:

Contract unit price for precast reinforced concrete flared end sections shall include grating.

Payment will be made under:

ITEM AR752412 PRECAST REINFORCED CONC. FES 12" – PER EACH.

DIVISION V – TURFING

ITEM 901 – SEEDING

DESCRIPTION

901-1.1

ADD:

Restoration, seeding and mulching beyond the limits of seeding and mulching shown in the plans (such as around electrical trenching areas, haul roads, staging areas, storage areas) shall be considered incidental to the contract.

MATERIALS

901-2.2 LIME

DELETE: Entire Section

CONSTRUCTION METHODS

901-3.2 DRY APPLICATION METHOD

DELETE: Entire Section

ADD:

- (a) Description: This work shall consist of furnishing, transporting and installing all seeds, plant or other materials required for:
 - 1. Any remedial operations in conformance with the plans as specified in these special provisions or as directed by the Resident Engineer.
- (b) General Requirements: The site will be in the following condition:
 - 1. The grade will be shaped to the elevation shown on the plans.
 - 2. The topsoil will be free of clods, stones, roots, sticks, rivulets, gullies, crusting, caking and have a soil particle size of no larger than 1".
- (c) Seeding Equipment: Seeding equipment shall meet the following requirements. Any other equipment deemed necessary shall be subject to the approval of the Resident Engineer.
 - 1. Disc: Any disc new for the use shall be in a good state of repair with sound, unbroken blades. The disc shall be weighted if necessary to achieve the required tillage depth.
 - 2. No-Till Planters and Drills: Rangeland type drills and no-till planters shall be designed specifically for the seeding of native grasses and forbs with depth control bands set at 1/4" - 1/8".
 - 3. Seedbed Preparation: Seedbed preparation methods shall be approved by the Resident Engineer. Cultivation shall be accomplished at such a time that seeding may occur immediately and without delay. No seeds shall be sown until the Seedbed has been approved by the Resident Engineer.

- (d) Seeding Methods: The Contractor shall submit for approval by the Resident Engineer and schedule for seeding and/or planting at least two weeks prior to the scheduled commencement of work. Broadcast seeders will not be allowed. Seeder will be a drill type planter. The Resident Engineer shall examine and then approve any equipment to be used. Prior to starting work, all seeding equipment shall be calibrated and adjusted to sow seeds at the proper seeding rate. Equipment shall be operated in a manner to insure complete coverage of the entire area to be seeded. The Resident Engineer shall be notified forty-eight (48) hours prior to beginning the seeding operations. Any gaps between areas of growth greater than eight square feet shall be re-sown and/or replanted.
1. No-till or Drill Method: Rolling of the Seedbed will not be required with the use of rangeland type grass drill or no-till planters.

901-3.3 WET APPLICATION METHOD

DELETE: Entire Section.

METHOD OF MEASUREMENT

901-4.1

ADD:

Areas of seeding not showing a uniform stand of grass in density and color shall not be approved for payment. Such areas shall be reseeded to the Owner's satisfaction at the Contractor's cost.

BASIS OF PAYMENT

901-5.1

ADD: Payment will be made under:

ITEM AR901510 SEEDING – PER ACRE.

ITEM 908 – MULCHING

908-1.1

ADD:

Restoration, seeding and mulching beyond the limits of seeding and mulching shown in the plans (such as lighting, cabling, signage, access roads, haul roads, staging area, storage area) shall be considered incidental to the contract.

MATERIALS

908-2.1 MULCH MATERIAL

REVISE: First sentence to read:

Material used for mulching shall be (D) Hydraulic Mulch – Heavy Duty.

Chemical Mulch Binder meeting the requirements per Section 1081.06 (a) (3) of the IDOT “Standard Specifications for Road and Bridge Construction”, latest edition shall be used as a mulch stabilizer.

CONSTRUCTION

908-3.1 MULCHING

ADD:

Chemical mulch binder shall be mixed and applied per the manufacturer’s recommendations.

BASIS OF PAYMENT

908-5.1

ADD:

Chemical mulch binder shall not be paid for separately but shall be included in the unit bid price for mulching.

Payment will be made under:

ITEM AR908510 MULCHING – PER ACRE.

DIVISION VI - LIGHTING INSTALLATION

ITEM 106000 ROADWAY LIGHTING

DESCRIPTION

106-1.1

This item shall consist of furnishing and installing fuel farm light, bracket, pole, foundation, internal wiring, fuses, vibration dampers and all accessories required, at the locations shown on the plans or as directed by the Engineer.

EQUIPMENT AND MATERIALS

106-2.1 LIGHT FIXTURE

Luminaire shall be LED type, with 1 LED engine (73 Watts), operated on 120V or multi-volt ballast as indicated on the plans. The housing shall be constructed of heavy-gauge aluminum with no seams, weld beads or any other visible disturbances on the surface of the housing. All the internal and external hardware shall be stainless steel.

The lens shall be thermal and shock resistant glass and shall be sealed to the frame and secured with four retainer clips. The lens frame shall be piano hinged to the housing.

The reflector system shall be Electro brightened anodized and sealed aluminum. The reflector shall be mounted to a one-piece reflector mask, hinged to the housing for easy access to the ballast compartment.

The ballast shall be tray mounted and rated for -20°F operation.

The fixture shall be treated, primed, baked, covered with a high solids polyester finish and baked again. The final finish shall match with light pole or as directed by the Engineer.

Luminaires shall be Cat. No. DSX1-LED-1-B700/40K-PE (Photocell)-MVOLT as manufactured by Lithonia or approved equal.

106-2.2 LIGHT POLE

The proposed poles shall be 15' tall round tapered steel poles fabricated from one piece weldable grade carbon steel with uniform wall thickness of .250". The material shall conform to ASTM A-500 grade B with minimum yield strength of 46,000 PSI. The weld shall be full length longitudinal weld. The anchor base shall be structural quality hot rolled carbon steel plate shall be welded to the shaft at top and bottom. The anchor bolts shall be provided by the pole manufacturer and shall be fabricated from commercial quality hot rolled carbon steel bar with minimum yield strength of 50,000 PSI. The top 8" of the anchor bolts shall be galvanized as detailed on the plans. The proposed poles shall be furnished with hand holes located above the base. Each pole shall be furnished with mounting hardware and vibration damper as detailed on the plans and required by the manufacturer. The proposed poles shall be furnished with an inside and outside coating of red oxide I zinc chromate primer. The color shall be dark bronze. The proposed pole shall as manufactured by Valmont or equal.

All poles supplied shall be certified to be vibration free at all wind loads.

106-2.3 LIGHT POLE FOUNDATION

Foundations for Light Pole shall be 24" diameter and extend 8' below finished grade. Reinforcing steel shall be installed as detailed on the plans.

Anchor bolts shall be supplied by the pole manufacturer and shall be installed according to his recommendations. Anchor bolts shall be "L" shaped and shall be minimum 1" diameter, 36" long with 7" "L" unless otherwise recommended by the pole manufacturer.

Foundations shall conform to the applicable sections of Item 610 of the Standard Specifications. Light pole foundations shall extend 1" above finished grade.

106-2.4 INTERNAL WIRINGS

All fusing shall be accessible through the pole handhole for the light poles. Contractor shall provide the waterproof splices, breakaway fuse holders, fuses and other miscellaneous items necessary for a complete installation. The breakaway fuse holders and fuses shall be manufactured by Bussman or equal. All splicing of wiring from main power wiring to #10 wiring within pole shall be done inside the handhole at each pole. All fuses and lightning arrestors shall be within the light pole handhole.

106-2.5 GROUND RODS

All light poles shall be furnished with a ground rod as detailed in the plans. The proposed ground rods shall be 3/4" diameter, 10' long copper clad. The top of the rod shall be buried min. 12" below finished grade. All the connections to the ground rod shall be buried min. 12" below finished grade. All the connections to the ground rods shall be one shot exothermic welding as manufactured by Cadweld or equal.

106-2.6 OBSTRUCTION LIGHT

Obstruction light shall be FAA approved L-810, LED type as manufactured by ADB or approved equal. Obstruction light shall be connected to the area light circuit, without photocell control to be operational 24 hours.

CONSTRUCTION METHODS

106-3.1 POLES AND LUMINARIES

Poles and luminaires shall be assembled and wired on the ground, then lifted and bolted in place plumb. The pole shall be considered plumb when the center of the top is directly over the center of the base. Plumb is to be measured with a transit by the Resident Engineer.

Wiring run from luminaire to pole base shall have a strain relief clamp provided at the entry to the luminaire to prevent the wires from pulling loose from their terminals at the luminaire.

Internal wiring of poles and luminaires including fuses and waterproof splices shall be incidental to this item. Poles and luminaires shall be set on their foundations such that the luminaires aim in the direction indicated on the plans.

All proposed poles shall be grounded to ground rods. Contractor shall use one shot exothermic weld by Cadweld or equal.

106-3.2 LIGHT POLE FOUNDATIONS

The Contractor shall be responsible for the necessary concreting and formwork to install the foundations as detailed on the plans.

The Contractor is referred to Section 610 of the Standard Specifications, which covers the proper installation of the concrete.

Foundations shall extend for 8' below finished grade or pavement. Foundations shall extend one inch above finished grade.

Anchor bolts shall be set according to the bolt circle requirements of the poles supplied. They shall be so arranged that when the pole and luminaire is erected, the luminaire will be properly aimed.

106-3.3 POWER AND CONTROL

The location of power and control materials and work to be performed shall be as indicated in the plans. Electrical cable is covered in Section 108, The Contractor shall furnish and install identifying tags on all wires at the point where they connect to the breaker indicating which lights the wires serve. The Contractor shall stencil an identifying label on the control panel enclosure.

106-3.4 RESTORATION

All areas disturbed by the light fixture installation storing of dirt and other work shall be restored to its original condition. The restoration shall include any necessary topsoiling, fertilizing, seeding or sodding and shall be performed in accordance with the Standard Turfing Specifications. The Contractor shall be held responsible for maintaining all disturbed surfaces and replacements until final acceptance.

METHOD OF MEASUREMENT

106-4.1

The quantity of light poles to be paid for under this item shall be the number of units furnished and installed ready for operation. Each unit shall consist of the fixtures, brackets, fuses, internal wiring, ground rods, light pole foundations, obstruction light, cable/conduit as shown on the plans and any miscellaneous items and fittings required to make the unit operational.

Each unit shall consist of the ballast, housing, and any other items required for successful operations.

The quantity for the lighting circuit, 2#10XLP-USE, 1# 10 GND in 1" GRS Conduit as shown on the plans and specified in Section 108 shall not be measured for payment, it shall be incidental to the pay item for light pole pay item.

BASIS OF PAYMENT

106-5.1

Payment will be made at the contract unit price for each light pole complete with 1 fixture, obstruction light, power cable/conduit, electrical wiring, ground rods and foundation and any other accessories completed by the Contractor and accepted by the Engineer. These prices shall consist of full compensation for furnishing and material, backfilling and compacting trenches, and for all labor, equipment, tools, and incidentals necessary to complete this item.

If, upon delivery and incorporation of any materials, the Contractor has failed to provide the necessary submittals as required by Sections 30-18, 40-01, 40-03 and 40-11 of the Standard and Special Provisions, the pay item shall not be included on the Construction Progress Payment report until such submittals have been furnished.

Payment will be made under

ITEM AR910110 RDWY LIGHT POLE W/ FIXTURE - PER EACH

ITEM 108 – INSTALLATION OF UNDERGROUND CABLE FOR AIRPORTS

DESCRIPTION

108-1.1

DELETE: The 3rd sentence of the first paragraph.

ADD:

This item of work shall consist of the underground installation of 600V power cables and controls/communication cables in GRS conduit at the locations shown on the plans, as required by the fuel farm manufacturer and in accordance with these specifications. When crossing existing utilities or as required by the Engineer, the Contractor shall hand dig the trenches for the proposed cables.

Contractor shall color code all airfield lighting cables in ducts, manholes and handholes as directed by the Engineer. All costs of color-coding shall be considered incidental to the contract unit price for the associated item.

EQUIPMENT AND MATERIALS

108-2.1 GENERAL

ADD:

Airfield Lighting cable under this item shall be:

- 1/C # 2 XLP-USE, 600 V cable in conduit
- 1/C # 2 GROUND, 600V cable in conduit
- 1/C # 10 XLP-USE, 600 V cable in conduit
- 1/C # 10 GROUND, 600V cable in conduit
- Communication/controls cables in conduit

108-2.4 CABLE CONNECTIONS

DELETE: The first and second sentence of paragraph **D. The Taped or Heat-Shrunked Splice.**

ADD:

To further reduce the possibility of water (moisture) entrance into the connector between the cable and the field attached connector, heat shrinkable tubing with interior adhesive shall be applied over all cable connections.

The heat shrinkable tubing shall cover the entire L-823 connector. All connections shall be at manholes or light bases. No direct burial splicing will be allowed.

No splices will be allowed in the new cable unless at the end of a spool of cable. Splices due to termination points shall be done in splice cans, manholes, handholes and light cans. Any repairs necessary to cable damaged during installation shall be done at the Contractor's expense and shall consist of replacing the entire length of damaged cable between pull points.

In line connections for existing cables to be spliced or those which are cut during construction shall be repaired with the cast splice kit. The Contractor shall have a minimum of five (5) splice kits on the jobsite at all times for emergency repairs. Splice markers shall be installed over each splice in cables not to be abandoned. Cast splice kits shall be as specified in paragraph (a). All field splices shall be covered with a flexible polyolefin heat-shrinkable sleeve.

CONSTRUCTION METHODS

108-3.1 GENERAL

ADD:

Any damages to existing utilities as a result of the Contractor's operations shall be repaired immediately at his expense.

108-3.2 INSTALLATION IN DUCT OR CONDUIT

ADD:

The Contractor shall install GRS conduit and conduit seals as shown on the plans.

The Contractor shall coordinate the cable trenching, placement and backfilling operations so that the cable will not be damaged by (a) the use of mechanized road building equipment in the area where underground cable is or will be in existence, and (b) stone or other foreign materials falling into the trench or mixing into the trench backfill materials.

108-3.3 TRENCHING

REVISE 24" to 30" in the last sentence of the second paragraph.

ADD:

The installation of GRS conduit using the plowing in method shall not be acceptable.

108-3.5 SPLICING

DELETE: The first and second paragraph of Section **D. Taped or Heat-Shrunked Splices.**

ADD:

Contractor shall use cast splicing kits as described in Article 108-2.4 for any splices made inside the electric handholes and manholes. The cast splicing kit shall be series 82-B1 Scotch cast or 90-B1 Scotch cast as manufactured by 3M or equal. Contractor shall provide shop drawing for splicing method and cast splicing kit. Contractor shall also leave minimum 30" of slack on each side of the cable being spliced.

Splicing of FAA cables shall be tested and approved by FAA.

108-3.10 LOCATING OF EXISTING CABLES

ADD:

Contact Personnel are listed in Section 70-17 herein.

108-3.11 TERMINATIONS AND CONNECTIONS

REVISE: In paragraph 3, the number of splice kits required on site from two (2) to five (5).

ADD:

If, due to the length of spool ordered by the Contractor, it is necessary to install additional handholes, the Contractor shall supply same at no additional cost to the project. The handhole shall be the size as directed by the Engineer.

METHOD OF MEASUREMENT

108-4.1

DELETE: This Section.

108-4.2

REVISE: This Section to read as follows.

The length of 1/C #2 XLP-USE and 1/C #2 Ground (600V) and 1/C #10 XLP-USE and 1/C #10 Ground (600V) cable installed in the proposed conduit and all power/control cables associated with fuel farm shall not be measured for payment, it shall be considered incidental to the pay items for light pole and fuel farm electric service.

BASIS OF PAYMENT

108-5.1

REVISE: This Section to read as follows:

The cables specified under this items shall not be paid under this item. Cables incidental to associated pay items shall be full compensation for furnishing all materials and for all preparation and installation of these materials, trenching, backfilling and compacting trenches, all connections, line marking tape and installation, and for all labor, equipment, tools and incidentals necessary to complete these items.

ITEM 110 – INSTALLATION OF AIRPORT UNDERGROUND ELECTRICAL DUCT

DESCRIPTION

110-1.1

ADD:

This item shall consist of the construction of new GRS conduit and conduit seals for electrical and communication for the fuel farm facility, including appropriate duct markers at the locations shown in the plans or as directed by the Engineer.

Contractor shall provide pull wire for each conduit and cap the unused conduits for future use.

EQUIPMENT AND MATERIALS

110-2.9 DUCT MARKER

ADD:

The Contractor shall provide duct markers for each new or existing duct being used as detailed in the plans. The cost of installation of the duct markers shall be incidental to the contract.

Brass duct markers shall only be used at bituminous pavement locations as shown on the plans. At concrete pavement locations, the Contractor shall stamp the concrete as directed by the Engineer.

Contractor shall provide duct markers for each proposed concrete encased duct or existing duct being used as detailed in the plans. Contractor shall also replace all existing duct markers within the project concrete overlay and bituminous overlay limits as detailed in the plans. The cost of replacement and installation of the duct markers shall be incidental to the contract.

110-2.12 AGGREGATE BACKFILL

ADD:

Crushed aggregate material conforming to the requirements of Item 208-2.3 Gradation, Table 1 or as approved by the Engineer shall be used for backfill at the pavement crossings for the proposed duct installation. The granular material shall be compacted to not less than 95% of Modified Proctor laboratory density. In lieu of aggregate, the Contractor may substitute Controlled low strength material (CLSM) backfill for those areas requiring aggregate backfill. This substitution must be approved in writing prior to construction and must be completed at no additional cost to the contract. CLSM shall meet the requirements of IDOT *Standard Specifications for Road and Bridge Construction (latest edition)*, Section 593. The CLSM material will be considered incidental to the associated duct item.

CONSTRUCTION METHODS

110-3.5 BACKFILL

ADD:

Crushed Stone conforming to the requirements of Item 208 gradation shall be used for backfill at the pavement crossings for the new duct installation. The granular material shall be compacted to not less than 95% of Standard Proctor laboratory density.

METHOD OF MEASUREMENT

110-4.1

DELETE: This Section.

ADD:

The quantity of GRS conduits for electric service, lighting circuit and power/communication shall not be measured for payment, it shall be considered incidental to the pay items for light pole and fuel farm electric service. The cost of trench excavation and backfill shall not be measured separately for payment, but shall be considered incidental to the respective pay item associated with the work.

BASIS OF PAYMENT

110-5.1

DELETE: Entire Section.

ADD:

The GRS conduit specified under this items shall not be paid under this item. GRS conduit installation incidental to associated pay items shall be full compensation for furnishing all materials and for all preparation, assembly, aggregate backfill, backfill, compaction, sawcutting and installation of these materials, and for all labor, equipment, tools, and incidentals necessary to complete these items.

Topsoiling and seeding of the duct and conduit trench shall not be paid for separately but shall be considered incidental to the associated pay item.

ITEM 125 – INSTALLATION OF AIRPORT LIGHTING SYSTEMS

DESCRIPTION

125-1.1

ADD:

Airfield lighting improvements and modifications shall include:

- Removal of existing elevated retroreflective markers.

125-1.7 GUARANTEE

All equipment furnished and work performed under the Contract Documents shall be guaranteed against defects in materials or workmanship for a period of one (1) year from the date of final acceptance. This guarantee does not replace any responsibility for errors or omissions as set forth in state law. Any long-term warranties issued or offered by manufacturers for items of equipment shall be turned over to the Airport.

125-1.8

Any failure of equipment or work due to defects in materials or workmanship shall be corrected by the Contractor at no cost to the Airport.

125-1.9

The Contractor shall ascertain that all lighting system components furnished by him (including FAA approved equipment) are compatible in all respects with each other and the remainder of the new/existing system. Any incompatible components furnished by the Contractor shall be replaced by him at no additional cost to the Airport with a similar unit approved by the Project Engineer (different model or manufacturer) that is compatible with the remainder of the airport lighting system.

125-1.10

The Contractor-installed equipment (including FAA approved) shall not generate any electromagnetic interference in the existing and/or new communications, weather and air traffic control equipment. Any equipment generating such interferences shall be replaced by the Contractor at no additional cost with the equipment meeting applicable specifications and not generating any interference.

EQUIPMENT AND MATERIALS

125-2.1 GENERAL

ADD:

All new equipment shall be listed in Advisory Circular 150/5345-53 (Latest Edition) – Airport Lighting Equipment Certification Program.

Before any electrical materials are ordered, the Contractor shall furnish the Engineer a list of the materials and equipment to be incorporated in the work. This list shall include the name of each item, the Federal Aviation Administration specification number, the manufacturer's name, the manufacturer's catalog number, and the size, type and/or rating of each item, catalog cuts, test data, fuse curves, outline drawings, nameplate drawings, wiring diagrams, and schematic diagrams.

After the list has been approved by the Engineer and prior to installation, the Contractor shall assemble the equipment and materials at a single location, on-site, and request inspection by the Engineer. None of the equipment or materials, other than duct or conduit, may be used on the job until such as inspection has been completed.

All test results from required tests shall be submitted to the Engineer for review and approval.

Airport lighting equipment and materials covered by FAA specifications shall have prior approval of the Federal Aviation Administration, Airport Service, Washington, DC 20591, and shall be listed in the current edition of FAA Advisory Circular AC 150/5345-53, Airport Lighting Equipment Certification Program. All other equipment and materials covered by other referenced specifications shall be subject to acceptance through manufacturer's certification of compliance with the applicable specification, when required by the Engineer.

The following documents, of the issue in effect on the date of application for qualification, are applicable to the extent specified:

<u>Item</u>	<u>Specification</u>	<u>Advisory Circular</u>
Elevated Marker	L-853	AC 150/5345-39D

All FAA Advisory Circular referenced in this specification refer to the most recent edition in circulation.

125-2.14 ELEVATED RETROREFLECTIVE MARKERS

ADD:

Elevated Retroreflective Markers shall be omnidirectional, frangible markers of the color and mounting type as detailed on the plans.

METHOD OF MEASUREMENT

125-4.1

DELETE: Entire section.

ADD:

The quantities to be paid for under this item shall consist of:

- (a) The number of elevated retroreflective markers (Type 2) installed in place as complete units, ready for operation and accepted by the Engineer.
- (b) The number of elevated retroreflective markers removed, salvaged, and presented to the Airport in its existing condition at the time of removal.

BASIS OF PAYMENT

125-5.1

ADD:

Payment will be made at the contract unit price for each complete item furnished and installed in place by the Contractor and accepted by the Engineer. This price shall be full compensation for furnishing all materials and for all preparation, removals, modifications, relocation, assembly, and installation of these materials, and for all labor, equipment, tools, and incidentals necessary to complete this item.

Payment will be made under:

ITEM AR800194 REMOVE ELEVATED RETROREFLECTIVE MARKER –PER EACH.

DIVISION VIII – MISCELLANEOUS

ITEM 800 – REMOVE FUEL FARM

DESCRIPTION

800-1.1

The work covered under this provision shall be for the removal of the existing underground storage tank fuel farm, two (2) 10,000-gal fuel underground fuel storage tanks containing 100LL and Jet A fuel, dispensers, piping, electrical, existing pavement (as noted on the plans), all required earth excavation and replacement, backfill, landscaping, and all other items required per regulations of the Office of the State Fire Marshal under Title 41 Ill. Admin. Code 175.830 (Removal of UST's) and 176.330 (Procedures for Site Assessments).

MATERIALS

800-2.1

All materials used for underground storage tank removal shall at a minimum comply with regulations of the Office of the State Fire Marshal under Title 41 Ill. Admin. Code 175.830 (Removal of UST's). All contractors to be used for actual removal activities must be registered with the Office of the State Fire Marshal and have a minimum of five (5) years in the business of removing underground storage tanks.

CONSTRUCTION METHODS

800-3.1

Before the existing fuel farm can be removed, the new above ground storage tanks and dispensing systems must be fully operational so that the Owner does not experience times when fuel is not available for its customers.

Before removal of existing fuel farm, contractor shall be responsible for transferring any remaining useable fuel from existing underground tanks to corresponding new fuel tanks. All fuel (Jet A and 100LL) shall be filtered before being placed into new tanks.

Upon issuance of a Notice To Proceed, an OSFM registered contractor shall submit an application and applicable permit fees to the OSFM Division of Petroleum and Chemical Safety and secure a permit for removal of the existing underground storage tank, piping, vents, dispensers, pumps, and any additional ancillary equipment (fences, gates, bollards, guard rails, power panels, conduits, etc). Schedule the removal date and provide a minimum of 72 hours of notice to the Owner and Engineer to be present for the removal. Coordinate with the Owner in advance when scheduling and completing the transfer of remaining useable fuel removed from UST's to the new fueling system.

On the day of removal, pump out all remaining liquid from the tank and dispose of per applicable regulations. Uncover tank and prepare for removal, including ventilation, cutting straps and removing remaining backfill to completely expose top to tank. Remove tank under direction of an OSFM inspector, or their designated representative and place tank on 6 mil (minimum) plastic sheeting away from excavation. Open tanks with non-sparking tools, continue to ventilate, and remove any remaining accumulations of water, product or tank sludge. Any removed liquid or sludge, shall be removed, placed in appropriate containers and disposed of per applicable regulations. Provide evidence of proper disposal (manifests) to the Owner. Tank shall be destroyed by cutting holes in the surface equal to 2% of tank surface area, or more. Properly dispose of tank and provide evidence of

proper disposal (scrap yard or landfill receipts) to Owner. Backfill remaining excavation in accordance with Section 701-3.5 of the Standard Specifications to match existing grade.

After removal of tank, contractor shall retain necessary personnel to conduct a Site Assessment of the tank excavation in areas where contamination is most likely to occur in and around the tank excavation. Provide analyses, prepare report and submit per OSFM regulations. Provide copies of all submittals to the Owner. In the event that a release is required to be reported, assist the Owner with reporting by providing any additional information related to the assessment already collected.

Should removal of petroleum contaminated soil be required, contractor will perform all necessary sampling of material to be disposed of per the accepting landfill's and Illinois Environmental Protection Agency's requirements. Contractor shall furnish completed manifests and load tickets for each load of disposed soil that show disposal at a permitted solid waste landfill. If removal of petroleum contaminated water is required, contractor shall also provide completed manifests and load tickets for each load of water that show disposal at an approved transportation, storage and disposal (TSD) facility.

METHOD OF MEASUREMENT

800-4.1

The quantities of this item will be based on a lump sum basis and shall include all labor and materials to remove to the two (2) existing underground fuel storage tanks (100LL and Jet A) and all other items associated with the fueling system, all required excavation (regardless of clean or suspected contaminated material) and backfill, permit and disposal fees, and accessory items as described herein including permit and disposal fees, inclusive of all items and efforts to perform a complete removal and assessment as described herein. Petroleum contaminated soil and water transfer and proper disposal, if required, shall be measured for payment separately. For the purposes of bidding, a limited amount (in cubic yards) of transfer and disposal has been estimated for this project.

Restoration of disturbed area, including all final grading, topsoiling, seeding, mulching shall not be measured for payment in this area, but shall be included in the lump sum unit cost of REMOVE FUEL FARM.

All required excavation, regardless of clean or suspected contaminated material, will not be measured separately for payment, but shall be included in the lump sum Contract unit price for REMOVE FUEL FARM. CONTAMINATED SOIL REMOVAL shall include only the transfer and proper disposal of the material.

BASIS OF PAYMENT

800-5.1

The basis of payment for this item shall be lump sum inclusive of all labor and materials to remove the existing fuel tanks and system, and accessory items as described herein, inclusive of all items and efforts to perform a complete removal and assessment as described herein. No payment for petroleum contaminated soil removal will be made without the advance written authorization of the Engineer.

Payment will be made under:

ITEM AR800012 REMOVE FUEL FARM – PER LUMP SUM.
ITEM AR800129 CONTAMINATED SOIL REMOVAL – PER CUBIC YARD.

ITEM 800 – FUEL FARM TANKS

DESCRIPTION

800-1.1

This section shall include all labor and materials to install aboveground storage tanks compatible with the fuels being stored (100LL and Jet A), pumping and filter/separator systems, enclosures, dispensers, hose reels, fuel tank gauging systems and power/control systems. Fuel for new tanks will be supplied by the Owner, but contractor must coordinate activities to allow for product deliveries. New tanks must be installed and operational before existing underground storage tanks and dispensing system can be removed.

MATERIALS

800-2.1

Fuel Tanks. Two (2) fuel tanks shall be provided as follows: 10,000 gallon capacity each, U.L. 2085 listed. Interior coating systems shall be compatible with the fuels being stored; one for 100LL Aviation Gasoline, and the other Jet A. Tanks shall be provided with at least one 24-inch diameter flanged manway and sufficient fittings as NPT half coupling connections to accommodate fills, supply lines, normal working vents, emergency vents (primary tank and interstitial space), secondary tank leak sensor, electronic tank monitoring probe and at least one spare connection to be fitted with a locking cap for manual tank gauging. Flanged manway covers shall be fitted with stainless steel welded flanges on both sides in order to accommodate floating suction.

Floating suction. Both tanks shall be equipped with aluminum floating suction assemblies sized to fit the specified tank. Floating suction assembly in the Jet A tank shall be 3 inch and shall be bolted to stainless steel flanged fittings on the bottom of the manway covers specified for the above ground tank. The AvGas tank shall be equipped with a 3-inch diameter assembly attached to the intake of the submersible pump. Floats shall be welded and equipped with a stainless steel test cable. All trim and fasteners shall be stainless steel and be otherwise compatible with stored fuels.

Fuel Dispensing System (100 LL AvGas only). The AvGas tank shall be fitted with a submersible turbine fuel pump, compatible with the stored fuel, hard piped to a cabinet style, remote dispenser equipped with a shear valve. The submersible pump motor shall be $\frac{3}{4}$ hp, 230VAC, 60 Hz, The dispenser shall have a mechanical display and register showing gallons and tenths. Unit shall be provided with a switch detect unit for connection to card reader system. Dispenser shall be equipped with spin-on filters and be hard piped to fuel hose reel specified below and equipped with internal fluorescent lighting. Fuel dispensing cabinet to be mounted to an integral spill containment pan attached to tank, or to a spill pan which can be affixed to the tank at installation.

Fuel Dispensing System (Jet A). The fuel dispensing system for the Jet A tank shall be a pre-packaged system comprised of pumps, filters, separators in a self-contained, skid-mounted enclosure. The fuel filter/separator system shall be a pre-fabricated and assembled unit constructed in accordance with API Specification 1581, ("Specifications and Qualification Procedures for Aviation Jet Fuel Filter/Separators"). The following list is intended to show major system components of the installed system but is not intended to necessarily be a complete checklist list of all parts and fittings. However, the Contractor shall be required to include all necessary components, parts and fittings in order to install a complete and functioning system.

- a. System shall have a nominal capacity of 100-200 gpm for off-loading and recirculation and a minimum capacity for direct fueling into aircraft of 25 gpm
- b. Cabinet. Complete enclosure of 16-gauge minimum stainless steel, and lockable latch with integral steel drip pan. Unit to be skid mounted, with anchor tabs and grounding lugs.

- c. Piping – 4 inch, diameter schedule 40 seamless stainless steel welded or flanged throughout.
- d. Pump, 4-inch positive displacement equipped with a sufficiently sized motor to deliver at the specified rate capable of operating on single phase, 230VAC, 60 Hz, and equipped with explosion proof motor, inlet strainer and pump inlet isolation valve with thermo relief and pressure relief by-pass valves, in addition to internal pressure relief.
- e. Internal overfill container capable of returning fuel test samples to suction side of pump.
- f. Pump control panel with motor starter, overload heaters, breakers and through-door disconnect handle, Pilot lights for Pump ON, Pump READY, Pump RUN, START/STOP pushbuttons, Emergency STOP maintained switch and reset button in NEMA 7 explosion proof enclosure. If control panel is not integral to the cabinet, it shall be separately mounted on stainless steel strut assembly immediately adjacent to fueling cabinet.
- g. Filter/Separator, with direct reading piston style pressure differential gauge (including piston hold and push button relief), air eliminator, pressure relief valve, spring loaded drain valve, up and downstream sampling probes, electronic water detection system, sump heater with thermostat, water drain valve, compatible cartridges for Jet A fuel.
- h. Meter, positive displacement with numerical counter, mechanical preset register and mechanical preset control valve.
- i. Interior Explosion Proof lighting, 60 watt minimum.
- j. Commissioning and startup by a factory authorized representative

Tank monitoring system. The tank monitoring system shall consist of display panel, magnetostrictive tank probes (one per tank), level switches and one (1) overfill alarm/acknowledge switch for both tanks. The system shall be capable of continually monitoring both tanks and displaying real-time data and equipped with an integral thermal printer. The monitoring panel shall be mounted in a weatherproof enclosure adjacent to the fuel farm as shown on the plans. The monitoring panel shall be equipped with a minimum of two inputs and two outputs for external devices and be capable of accepting up to eight interstitial or leak sensors and be capable of displaying audible in-tank warnings or alarms. Provide one level monitoring probe per tank, compatible with stored materials meeting dimension requirements of each tank with a leak detection rate of 0.1 gallons per hour. Provide interstitial leak sensors for each tank and leak sensors for areas beneath each dispensing unit. Include one overfill alarm/acknowledge switch to be mounted adjacent to the tanks that will sound an audible and visual alarm when tanks are filled to 90% of capacity and will output a signal for positive shutoff of filling systems when tanks reach 95% of capacity.

Static Ground Reel. Manual rewind, 50 ft. long, minimum length and alligator grounding clamp.

Hose Reels. Manual rewind, capable of holding up to 50 ft. of 1" (minimum) diameter hose,

Hoses (50 ft. per reel compatible with dispensed product), overwing dispensing nozzles, fittings, offsets, accessories and all related equipment needed to provide a complete and functioning fuel storage and dispensing system. Jet A nozzle shall be designed to not be compatible with fueling piston engine aircraft. Lever guard on the AvGas nozzle shall be red and on the Jet A nozzle it shall be black.

Fire Extinguishers. Provide two (2) 20 lb. Class 40B fire extinguishers and surface mounted cabinets. Cabinets to be galvanized or powder coated, glass or acrylic fronts with breaker bar and chain. Mount on uni-strut within 30 feet of each fuel dispenser as shown on plan.

800-2.2

New electric service shall be 100A, 120/240V, single phase at the location shown on the plans. The Contractor shall install new concrete pad for the utility transformer with conduits for primary and secondary cables. New power pedestal shall be furnished and installed as the location shown on the plans with following components:

- a. Galvanized Unistrut frame, posts and concrete foundations as detailed on the plans.
- b. Utility meter base as required by the utility company. Utility company shall install utility meter.
- c. 100A, 120/240V power panel in NEMA 3R enclosure with main circuit breaker and branch circuit breakers as indicated on the plans.
- d. Grounding system with ground rod and grounding conductors as detailed on the plans.
- e. Fuel farm controller in NEMA 3R enclosure, complete with dispensing pump starters, controls, oil/water separator, alarm indicator light and horn.
- f. Veeder-Root alarm monitoring system in NEMA 3R enclosure.
- g. Sensaphone Cell 682 cellular alarm dialer, complete with antenna, NEMA 3R enclosure, one-year subscription, programmed for alarms and notifications.
- h. ALL cables/conduits between utility transformer, utility meter, power panel, pump controller, veeder-root, sensaphone, oil/water separator, tanks, dispensing units, card reader and alarms.

CONSTRUCTION METHODS

800-3.1

Contractor shall verify that new fuel storage and dispensing system is fully operational prior to removing existing underground storage tanks and dispensing system. Any remaining useable fuel in the existing underground tanks shall be transferred to new tanks and be filtered prior to being introduced to new tanks.

Upon issuance of a Notice to Proceed, contractor shall apply for AST installation permit through the Office of the State Fire Marshal. Provide copies of all permit applications to Owner. Pay all required permit fees to State.

Upon permit issuance, coordinate any required inspection dates in advance with Owner. Verify that site is ready to receive tanks including concrete pad, conduits (number and size). Place tanks and pressure test in accordance with manufacturer's recommendations. Install probes, sensors, wiring, piping and other accessories.

Once tanks are installed, install dispensing systems and connect fuel piping and power to tank and energize systems. Pressure test all piping systems and correct all leaks or drips in system. Field test system to verify specified delivery and dispensing rates are attained.

Owner shall provide new fuel for tanks and contractor shall coordinate their work with the owner to allow tanks to be filled and put into operation in a timely manner.

800-3.2

Contractor shall furnish and install power, controls and communication cable/conduits as required by fuel farm manufacturer for a complete and operational system.

METHOD OF MEASUREMENT

800-4.1

The quantities of this item will be based on a per each basis, inclusive of all labor and materials to install the tank (and related accessories such as vents), provide and install dispensers, pumps, piping, fire extinguishers and cabinets, filter/separator component, hoses, reels and tank monitoring systems inclusive of all items and efforts to install a complete system as described herein, including filtering and transfer of remaining usable fuel to new tanks.

800-4.2

The quantity for all electrical work shall be lump sum, including but not limited to new electric service, transformer pad, power pedestal, power panel, grounding, sensaphone with 1 year subscription, emergency pushbutton, cable/conduits and fuel farm controllers.

BASIS OF PAYMENT

800-5.1

The basis of payment for this item shall be per each, inclusive of all labor and materials to install each tank (and related accessories such as vents), provide and install dispensers, pumps, piping, fire extinguishers and cabinets, filter/separator component, hoses, reels and tank monitoring systems inclusive of all items and efforts to install a complete system as described herein, including filtering and transfer of remaining usable fuel to new tanks.

Electrical work shall be paid for under a lump sum basis, which will include all electrical items and accessories as specified herein.

Payment will be made under:

ITEM AR800013	FUEL STORAGE TANK (100LL) - PER EACH.
ITEM AR800014	FUEL STORAGE TANK (JET A) - PER EACH.
ITEM AR800169	FUEL FARM ELECTRIC SERVICE – PER LUMP SUM.

ITEM 800 – CREDIT CARD READER

DESCRIPTION

800-1.1

This specification establishes the performance and design requirements for an Automated Fuel Management System that will control and record the dispensing of fuel from both above ground storage tank. The system shall be capable of unattended operation for 7 days a week, 24 hours a day. Products shall be limited to users/customers with authorized credit cards and/or read/write "SMARTCARDS" or keys. Dial up of the island key/card reader(s) shall be digital cellular modem as provided or recommended by the manufacturer. The fuel management system (automated data collection system) shall reliably read all credit cards and other access devices.

MATERIALS

800-2.1

The credit card reader (automated data collection) system shall as a minimum, consist of a key/card reader device located as shown on the fuel island, capable of turning fuel dispensers on and off, monitoring dispensed fuel, recognizing authorizing keys/cards, and with the capability to interface with the new dispensing systems and tank level monitoring systems. The system shall also be capable of dialing up the credit card clearing authority for credit acceptance prior to refueling of aircraft. Unit shall have an integral thermal printer, internal data logger, key or smart card encoder interfaced to the PC, Windows software to permit card encoding, manipulation of transaction data for printing reports on vehicles, users, products, etc., downloading of transactions and uploading of authorized user/vehicle lists and transfer and storage of data. Transaction data may be transferred to any program accepting a flat ASCII file, such as FBO management programs. Software must include an invoicing capability that allows the user to generate invoices for selectable customers or agencies from the central controller printer. Invoices must list each transaction for all equipment for a user-selected period. The card reader will store information from equipment refueled using credit cards; however, that information will be limited to date/time, amount of fuel, site, and product. Software must be Windows Professional XP, Vista, Windows 7 compatible.

CONSTRUCTION METHODS

800-3.1

Verify that all needed system components are installed and ready for use prior to proceeding. Install card reader unit as shown on the plan. Connect to available Owner PC and install required software. Interface with tank monitoring system. Verify that card encoding system functions correctly and that credit cards operate as designed.

The supplier shall provide on-site training of personnel in the functions of operation, maintenance, and repair as they apply to each specific item of equipment. Supervisors and operators at each refueling site will be provided training in the operation of the island fuel management units.

METHOD OF MEASUREMENT

800-4.1

The quantities of this item will be based on a per each basis, inclusive of all labor and materials to install the credit card reader system and accessories, and inclusive of all items and efforts to install a complete system as described herein.

BASIS OF PAYMENT

800-5.1

The Contract unit price shall include all labor and materials to install the credit card reader system and accessories, inclusive of all items and efforts to install a complete system as described herein.

Payment will be made under:

ITEM AR800040 CREDIT CARD READER - PER EACH.

ITEM 800 – OIL WATER SEPARATOR

DESCRIPTION

800-1.1

This section shall include all labor and materials to install one 1,000 gallon underground oil-water separator as shown on the plans including connecting piping, dual position float switch, float switch annunciator panel, separator accessories, manholes and valves as required for a complete installation.

MATERIALS

800-2.1

Oil Water Separator. The oil water separator (OWS) shall be for underground installation and be single wall construction with a nominal capacity of 1,000 gallons, be certified by the manufacturer for a discharge quality of no more than 15 parts per million and bear a U.L. 2215 label. Fiberglass reinforced plastic (FRP) separators shall also bear a U.L. 1316 label. Steel separators shall also bear a U.L. 142 label and be protected with an STI-P3 cathodic protection system and cathodic protection monitoring system. The oil water separator shall be equipped with a dual position float valve and annunciator panel provided by the separator manufacturer. Annunciators shall provide both a local audible and visual alarm when oil levels reach pre-determined levels. Concrete deadmen, straps and turnbuckles to be provided by tank manufacturer.

Plug valves. Provide two (2) plug type valves, 4-inch diameter, mechanical joint, resilient seated eccentric plug, lever operated, Cast iron body, 316 SS bearing, styrene-butadiene rubber binder, 316 SS plug, NBR plug facing and stem seal, bolted cast iron bonnet with high solids epoxy dry film interior and exterior coating. Meets AWWA C517.

Ductile Iron Pipe and Fittings. Piping between manholes and oil water separators shall be 4-inch diameter Ductile Iron Pipe meeting AWWA C151 pressure class 350. Mechanical joints and flanged fittings shall conform to AWWA C111.

CONSTRUCTION METHODS

800-3.1

Verify that area is ready to have underground oil water separator installed including verification of invert elevations for inlet/outlet pipes as shown on plans. Excavate area to dimensions shown on plans, set tank and backfill per manufacturer's recommendations to top of tank. Install ductile iron pipe, valves, manway extensions, float switch and equipment risers to surface. Backfill remaining excavation to proposed grades. Wire and install oil level float switch and local annunciator panel. Verify installation before proceeding. Install manholes flush with surface as shown on plans and pour concrete housekeeping slabs to grades shown.

Upon completion of installation, contractor to provide properly executed OWS installation checklist from manufacturer to Engineer.

METHOD OF MEASUREMENT

800-4.1

The quantities of the oil water separator will be based on per each basis, inclusive of all labor and materials to install the oil water separator and accessories, inclusive of all items and efforts to install a complete system as described herein.

The quantities of the plug valves will be based per each unit installed inclusive of all labor and materials to install the plug valve and accessories inclusive of all items and efforts to install the valves as described herein.

BASIS OF PAYMENT

800-5.1

The basis of payment for this item shall be per each, inclusive of all labor and materials to install the oil water separator and accessories, and inclusive of all items and efforts to install a complete system as described herein.

The basis of payment of the plug valves will be based per each unit installed inclusive of all labor and materials to install the plug valve and accessories, and inclusive of all items and efforts to install the valves as described herein.

Payment will be made under:

ITEM AR800041 OIL/WATER SEPARATOR – PER EACH.
ITEM AR800042 PLUG VALVE – PER EACH.

ITEM 910420 – BOLLARD

DESCRIPTION

910420-1.1

This item shall consist of the installation of bollards as shown on the plans or as directed by the Engineer.

MATERIALS

910420-2.1

Materials shall be as shown on the plans. Concrete shall meet Item 610.

CONSTRUCTION METHODS

910420-3.1

Installation shall be as shown in the plans.

METHOD OF MEASUREMENT

910420-4.1

The bollards shall be measured per each satisfactorily installed and accepted by the Engineer.

BASIS OF PAYMENT

910420-5.1

Payment shall constitute full compensation for the construction of the bollards, including all materials, labor, tools, paint, equipment and necessary incidentals to complete this item of work.

Payment will be made under:

ITEM AR910420 BOLLARD - PER EACH.

IDOT DIVISION OF AERONAUTICS POLICY MEMORANDA

State of Illinois
Department of Transportation
Division of Aeronautics

POLICY MEMORANDUM

April 1, 2010

Springfield

Number: 87-2

TO: CONSULTING ENGINEERS

SUBJECT: DENSITY ACCEPTANCE OF BITUMINOUS PAVEMENTS

1. Introduction

This Policy Memorandum deals with the implementation of the bituminous density quality assurance specifications as outlined in the Standard Specifications for Construction of Airports, Sections 401-4.15 and 403-4.15.

II. Sampling

After completion of compaction and when the pavement has reached ambient temperature, the paved area shall be divided into Sublots of 500 tons per type of mix. One core sample (2 cores per sample) shall be taken from each Sublot. The longitudinal and transverse location for each sample shall be determined by use of a random number "Deck" provided by the Division. No core shall be taken closer than two (2) feet from the edge of the mat. A core extraction device shall be used to obtain all cores from the mat. All cores are to be taken by the contractor under the supervision and remain in the possession of the Engineer. It is imperative that the Engineer and the contractor realize that the cores are "money" and that improper coring, extraction, shipping and/or testing can be costly.

One mix sample per 1000 tons of mix laid shall be taken for Extraction, Maximum Specific Gravity (G_{mm}) and Air Void tests. The mix samples shall be sampled by the contractor and split in half.

The Resident Engineer shall randomly designate and send the split samples to an independent laboratory for testing. The laboratory will be verified to be ASTM-certified for all the required testing and be contracted through the Consultant. The frequency of testing split samples shall be 1 per 5000 tons. Higher frequencies may be necessary if the contractor's tests, and/or mix quality control are inconsistent.

III. Testing

All cores shall be tested for Bulk Specific Gravity (G_{sb}) in accordance with ASTM D2726 using Procedure 9.1, "For Specimens That Contain Moisture". The Theoretical Maximum Gravity (G_{mm}) shall be determined according to ASTM D2041, Procedure 7. From these tests the in-place air voids of the compacted pavement are calculated according to ASTM D3203 for "dense bituminous paving mixtures". Selection of the proper G_{mm} shall be based on a running average of four (4) tests per Lot.

- Eg. Lot 1 - Use the average of the two (2) tests for Lot 1.
Lot 2 - Use the average of the four (4) tests from Lots 1 and 2.
Lot 3 - Use the average of the four (4) tests from Lots 2 and 3.

NOTE: When more than four (4) Sublots are used, still use a running average of four (4) tests per Lot.

IV. Acceptance Calculations

The first step in calculating the quantities for pay is to calculate the Mean (\bar{x}) and the Standard Deviation (S) of the Sublot tests. From this data the Lot samples should first be tested for outliers. After consideration for outliers, the Percent Within Tolerance (PWT) and the Percent Within Limits (PWL) are calculated to determine the final pay quantities for the Lot.

EXAMPLE

1. Test Data

Lot Quantity = 2000 tons
Sublot Test 1 = 4.35 % Air Voids
Sublot Test 2 = 3.96 % Air Voids
Sublot Test 3 = 6.75 % Air Voids
Sublot Test 4 = 6.25 % Air Voids

2. Calculating the Mean and Standard Deviation

Sublot	\underline{x}	$(\underline{x} - \bar{x})$	$(\underline{x} - \bar{x})^2$
1	4.35	- 0.978	0.956
2	3.96	- 1.368	1.871
3	6.75	1.422	2.022
4	<u>6.25</u>	0.922	<u>0.850</u>
Sum =	21.31		5.699

$$N = 4$$

$$\text{Mean}(\bar{x}) = 21.34 / 4 = 5.328$$

$$\text{Variance } (S)^2 = \frac{\text{Sum}(x - \bar{x})^2}{3} = \frac{5.699}{3} = 1.900$$

$$\text{Standard Deviation } S = \sqrt{1.900} = 1.378$$

3. Test For Outliers

Check for Critical "T" Values

$$T = \frac{|(x_1 - \bar{x})|}{S} = \frac{|3.96 - 5.328|}{1.378} = 0.99$$

* Difference between the suspect test value (x_1) and the Mean (\bar{x}).

If the T value exceeds the critical "T" Value in the table below and no assignable cause can be determined for the outlier, discard the suspected test measurement and obtain another random sample from the Sublot in question. If the new test exceeds the Mean (\bar{x}) in the same direction from the Mean as the suspected test, recalculate the T value including all tests (original test, suspected test, and new test) for an outlier and for computing final payment.

TABLE OF CRITICAL "T" VALUES

Number of observations (N)	Critical "T" Value 5% Significance Level
3	1.15
4	1.46
5	1.67
6	1.82
7	1.94
8	2.03
9	2.11
10	2.18
11	2.23
12	2.29

Based on the above table, the "T" value of 0.99 does not exceed the Critical "T" Value of 1.46 for N = 4. Therefore, the value (3.96) is not an outlier and shall be used in calculating the Lot payment.

4. Calculation of Lot Payment

To calculate the Lot Payment use the Acceptance Criteria as outlined under Item 401-4.15(c) or Item 403-4.15(c).

$$Q_L = \frac{(\bar{x} - 1)}{S} = \frac{5.328 - 1}{1.378} = 3.141$$

$$Q_u = \frac{(7 - \bar{X})}{S} = \frac{7 - 5.328}{1.378} = 1.213$$

From this data the Percentage Within Tolerance (PWT) for both the lower and upper tolerance limits is determined by Table 6 (see Item 401 Bituminous Surface Course and/or Item 403 Bituminous Base Course in the Standard Specifications) for the number (N) of samples tested.

Eq. PWT (lower) = 99.0%
 PWT (upper) = 90.4%

We now calculate the Percent Within Limits (PWL) for the Lot.

PWL = [PWT (lower)] + [PWT (upper)] - 100
 PWL = (99.0 + 90.4) - 100 = 89.4%

Using Table 5, the % Adjustment in Lot Quantity is:

% Adjustment = 0.5 PWL + 55.0
 % Adjustment = 0.5 (89.4) + 55.0
 % Adjustment = 99.7

Adjusted Quantities = % Adjustment x Lot Quantities
 Adjusted Quantities = 0.997 x 2000 tons
 Adjusted Quantities = 1994 tons

5. Resampling and Retesting

The contractor has the right to request the resampling and retesting of a complete Lot. This privilege is only allowed once for each Lot and must be requested in writing by the contractor within 48 hours of receiving the official report from the Engineer.

6. Reporting

After completion of the tests for each Lot, the Engineer shall complete the necessary calculations for final adjustment in quantities on the Form AER-1 and have both the Engineer and the Contractor sign the report for copying to both the FAA and IDOA.

Steven J. Long, P.E.
 Acting Chief Engineer

Supersedes Policy Memorandum 87-2, dated January 1, 2004.

State of Illinois
Department of Transportation
Division of Aeronautics

POLICY MEMORANDUM

January 1, 2004

Springfield

Number: **87-4**

TO: CONSULTING ENGINEERS

SUBJECT: DETERMINATION OF BULK SPECIFIC GRAVITY (d)
OF COMPACTED BITUMINOUS MIXES

- A. SCOPE. This method of test covers the determination of the bulk specific gravity and the percent air, of core samples from compacted bituminous mixtures using a saturated surface-dry procedure.
- B. DEFINITIONS.
1. Bulk Specific Gravity (G_{sb}) or density is the weight per unit volume (gms/cc) of a mixture in its existing state of consolidation. The volume measurement for this specific gravity will include the volume of all the aggregate, asphalt, and air spaces (voids) in the aggregate particles and between the aggregate particles.
 2. Theoretical Maximum Specific Gravity (G_{mm}) ASTM 2041 is the weight per unit volume (grams/cc) of a mixture assuming complete consolidation; i.e., all the air spaces (voids) between the aggregate particles are eliminated.
 3. Percent Density is a measure of the degree of compaction in relation to the Theoretical Maximum Specific Gravity.
 4. Percent Air is a measure of the air voids in the compacted pavement.
- C. APPARATUS.
1. Balance - The balance shall be accurate to 0.1 gm throughout the operating range. It may be mechanical or electrical and shall be equipped with a suitable suspension apparatus and holder to permit weighing of the core in water while suspended from the balance. If the balance is a beam type, it shall be set up so that the core is placed in the basket that is suspended from the zero (0) end of the balance arm.
 2. Water bath - The container for immersing the core in water while suspended from the balance shall be equipped with an overflow outlet for maintaining a constant water level. This water bath should be large enough to handle full-depth cores. When testing several cores at the same time, a dish-pan, sink or suitable container may be used for soaking.

D. PROCEDURE.

1. Prior to testing, cores shall be sorted on a flat surface in a cool place. The sample(s) shall be brushed with a wire brush and/or other suitable means, to remove all loose and/or foreign materials, such as seal coat, tack coat, foundation material, soil, paper, and foil, prior to testing.
2. If a core contains binder and surface or multiple lifts, the lifts shall be separated. This may be done in the following manner:
 - a. Mark the separation line between the two lifts.
 - b. Place the core in a freezer for 20-25 minutes.
 - c. Place a 2 or 3-inch wide chisel on the separation line and tap with a hammer. Rotate the core and continue this process until the core separates. Brush loose pieces with a wire brush if needed.
 - d. Allow 2-3 hours for the core to return to ambient temperature before proceeding.
3. Prepare the water baths for soaking and weighing with water at 77^o F. Water baths should be maintained at this temperature throughout testing. Saturate the cores by submerging in the water for a minimum of 20 minutes.
4. With the balance and water bath properly assembled and zeroed, suspend the sample from the balance and submerge it in the water bath. The core must be placed with the original top and bottom in a vertical position. If necessary, add sufficient water to bring the water level up to the overflow outlet. Permit any excess to overflow. Read and record the Saturated Submerged Weight. Designate this weight as (C).
5. Remove the core from the water bath and blot the excess water from the surface of the core with an absorbent cloth or other suitable material. This must be done quickly to prevent the internal water from escaping.
6. Place the core on the balance and read and record the Saturated Surface-dry Weight in air. Designate this weight as (B).
7. Place the core in a tared pan and dry in an oven. When the core is dry, (less than 0.5 gm loss in one hour) record the weight and subtract the pan weight. Designate this weight as (A).

8. The following calculation is used to determine the Bulk Specific Gravity of the core.

$$G_{sb} = \frac{A}{B-C}$$

G_{sb} = Bulk Specific Gravity
A = Oven dry weight
B = Saturated surface-dry weight
C = Saturated submerged weight

- E. PERCENT DENSITY. The following calculation is used to determine the percent density of the core:

$$\% \text{ Density} = 100 \times \frac{G_{sb}}{G_{mm}}$$

G_{sb} = Bulk Specific Gravity
 G_{mm} = Theoretical Maximum Gravity*

Note: The Theoretical Maximum Gravity (G_{mm}) is determined from the mix design until current Vacuum Pycnometer test are available.

- F. PERCENT AIR. To calculate the percent air, use the following formula:

$$\% \text{ Air} = 100 - \% \text{ Density}$$

- G. WEIGHT PER SQUARE YARD OF COMPACTED MIXTURE. The actual weight per square yard of a compacted mixture can be calculated by using the Bulk Specific Gravity (G_{sb}). The volume of a square yard of pavement one (1) inch thick is 0.75 cubic foot. Taking the weight of a cubic foot of water as 62.37 pounds, one square yard of compacted material, one (1) inch thick weighs:

$$\text{Pounds Per Sq. Yd. (1" thick)} = 0.75 \times 62.37 \times G_{sb}$$

Steven J. Long, P.E.
Acting Chief Engineer

Supersedes Policy Memorandum 87-4 effective January 1, 1994.

State of Illinois
Department of Transportation
Division of Aeronautics

POLICY MEMORANDUM

April 1, 2010

Springfield

Number 96-1

TO: CONSULTING ENGINEERS

SUBJECT: ITEM 610, STRUCTURAL PORTLAND CEMENT CONCRETE:
JOB MIX FORMULA APPROVAL & PRODUCTION TESTING.

- I. This policy memorandum addresses the Job Mix Formula (JMF) approval process and production testing requirements when Item 610 is specified for an airport construction contract.
- II. PROCESS
 - a. The contractor may submit a mix design with recent substantiating test data or he may submit a mix design generated by the Illinois Division of Highways with recent substantiating test data for approval consideration. The mix design should be submitted to the Resident Engineer.
 - b. The Resident Engineer should verify that each component of the proposed mix meets the requirements set forth under Item 610 of the *Standard Specifications for Construction of Airports* and/or the contract special provisions.
 - c. The mix design should also indicate the following information:
 1. The name, address, and producer/supplier number for the concrete.
 2. The source, producer/supplier number, gradation, quality, and SSD weight for the proposed coarse and fine aggregates.
 3. The source, producer/supplier number, type, and weight of the proposed flyash and/or cement.
 4. The source, producer/supplier number, dosage rate or dosage of all admixtures.
 - d. After completion of Items b and c above, the mix with substantiating test data shall be forwarded to the Division of Aeronautics for approval. Once the mix has been approved, the production testing shall be at the rate in Section III as specified herein.

III. PRODUCTION TESTING

- a. One set of cylinders or beams, depending on the strength specified, shall be cast for acceptance testing for each day the mix is used. In addition, at least one slump and one air test shall be conducted for each day the mix is used. If more than 100 c.y. of the mix is placed in a given day, additional tests at a frequency of 1 per 100 c.y. shall be taken for strength, slump, and air. The concrete shall have a maximum slump of three inches (3") and minimum slump of one inch (1") when tested in accordance with ASTM C-143. The air content of the concrete shall be between 5% and 8% by volume. At no time shall the temperature of the concrete exceed 90 degrees Fahrenheit.
- b. If the total proposed amount of Item 610 Structural Portland Cement Concrete as calculated by the Resident Engineer is less than 50 c.y. for the entire project, the following shall apply:
 - The Resident Engineer shall provide calculations of the quantity of Item 610 to the Division of Aeronautics.
 - One set of cylinders or beams, depending on the strength specified, shall be cast for acceptance testing.
 - One air content and one slump test shall be taken for acceptance testing.
 - The concrete shall have a maximum slump of three inches (3") and minimum of one inch (1") when tested in accordance with ASTM C-143. The air content of the concrete shall be between 5% and 8% by volume. At no time shall the temperature of the concrete exceed 90 degrees Fahrenheit.
- c. The Resident Engineer shall collect actual batch weight tickets for every batch of Item 610 concrete used for the project. The actual batch weight tickets shall be kept with the project records and shall be available upon request of the Department of Transportation.

Steven J. Long, P.E.
Acting Chief Engineer

Supersedes Policy Memorandum 96-1 dated January 1, 2004

State of Illinois
Department of Transportation
Division of Aeronautics

POLICY MEMORANDUM

April 1, 2010

Springfield, Illinois

Number 96-2

TO: CONTRACTORS

SUBJECT: REQUIREMENTS FOR LABORATORY, TESTING, QUALITY CONTROL, AND PAVING OF HMA CONCRETE MIXTURES

I. SCOPE

The purpose of this policy memorandum is to define to the Contractor the requirements concerning the laboratory, testing, Quality Control, and paving of HMA (Hot Mix Asphalt) mixtures. References are made to the most recent issue of the Standard Specifications for Construction of Airports and to American Society for Testing and Materials (ASTM) testing methods. The Quality Assurance and acceptance responsibilities of the Resident Engineer/Consultant are described in Policy Memorandum 96-3.

II. LABORATORY

The Contractor shall provide a laboratory located at the plant and approved by the Illinois Division of Aeronautics (IDA). The laboratory shall be of sufficient size and be furnished with the necessary equipment and supplies for adequately and safely performing the Contractor's Quality Control testing as well as the Resident Engineer's acceptance testing as described in Policy Memorandum 96-3.

The effective working area of the laboratory shall be a minimum of 600 square feet with a ceiling height of not less than 7.5 feet. Lighting shall be adequate to illuminate all working areas. It shall be equipped with heating and air conditioning units to maintain a temperature of 70° F ± 5° F.

The laboratory shall have equipment that is in good working order and that meets the requirements set forth in the following ASTM test standards:

ASTM C 117	Test Method for Materials Finer than 75 µm (No. 200) Sieve in Mineral Aggregates by Washing
ASTM C 136	Sieve or Screen Analysis of Fine and Coarse Aggregate
ASTM C 566	Total Moisture Content of Aggregate by Drying
ASTM D 75	Sampling Aggregates
ASTM D 1559	Resistance to Plastic Flow of Bituminous Mixtures Using Marshall Apparatus
ASTM D 2041	Theoretical Maximum Specific Gravity and Density of Bituminous Paving Mixtures
ASTM D 2172	Quantitative Extraction of Bitumen from Bituminous Paving Mixtures
IDOT	Ignition Method for Determining Asphalt Content

ASTM D 2726	Bulk Specific Gravity of Compacted Bituminous Mixtures using Saturated Surface Dry Specimens
ASTM D 3203	Percent Air Voids in Compacted Dense and Open Bituminous Paving Mixtures
ASTM D 2950	Density of Bituminous Concrete in Place by Nuclear Method
ASTM D 4125	Asphalt Content of Bituminous Mixtures by Nuclear Method
ASTM C 127	Standard Test Method for Specific Gravity and Absorption of Coarse Aggregate
ASTM C 128	Standard Test Method for Specific Gravity and Absorption of Fine Aggregate

The Asphalt Institute's *Mix Design Methods for Asphalt Concrete Manual No. 2 (MS-2)*

The laboratory and equipment furnished by the Contractor shall be properly calibrated and maintained. The Contractor shall maintain a record of calibration results at the laboratory. The Engineer may inspect measuring and testing devices at any time to confirm both calibration and condition. If the Resident Engineer determines that the equipment is not within the limits of dimensions or calibration described in the appropriate test method, he may stop production until corrective action is taken. If laboratory equipment becomes inoperable or insufficient to keep up with mix production testing, the Contractor shall cease mix production until adequate and/or sufficient equipment is provided.

III. MIX DESIGN SUBMITTAL

Based upon data and test results submitted by the Contractor, the Illinois Division of Aeronautics Engineer of Construction & Materials shall issue the final Job Mix Formula (JMF) approval letter that concurs or rejects the Contractor's proposed JMF. The Contractor will be required to perform the sampling and laboratory testing and develop a complete mix design, according to the following guidelines: [Note: A testing summary chart can be found in Appendix B.]

- A. Material sources meeting the requirements of the contract shall be submitted in writing at or before the preconstruction conference (see BITUMINOUS WORKSHEET in Appendix A) in the following format:
1. To: Steven J. Long, P.E., Acting Chief Engineer
Attn: Michael F. Wilhelm, P.E., Engineer of Construction & Materials
Division of Aeronautics
One Langhorne Bond Drive
Springfield, Illinois 62707
 2. Producer name and location of each aggregate
 3. Producer # for each aggregate (producers are assigned this number by IDOT Central Bureau of Materials)
 4. Material code for each aggregate
 5. Gradation and Quality designation for each aggregate (i.e. CA-11, etc.)
 6. Producer, producer #, and specific gravities of asphalt cement

7. Performance Graded Binder 64-22 shall be used unless otherwise approved by the IDA Engineer of Construction & Materials.
- B. The Contractor shall obtain representative samples of each aggregate. The individual obtaining samples shall have successfully completed the IDOT Aggregate Technician Course under the IDOT Division of Highways, QC/QA program. The sample size shall be approximately 280 lb. for each coarse aggregate, 150 lb. for each fine aggregate, 15 lb. for the mineral filler or collected dust, and 1 gallon of asphalt cement.
- C. The Contractor shall split the aggregate samples down and run gradation tests according to the testing methods referenced in Appendix B of this memorandum. The remaining aggregates shall be set aside for further Mix Design testing. The results of the gradation tests, along with the most recent stockpile gradations, shall be reported by fax to the IDA Engineer of Construction & Materials for engineering evaluation. If the gradation results are deemed non-representative or in any way unacceptable, new representative samples may be required at the direction of the IDA Engineer of Construction & Materials. Only composite gradations are required under this procedure.
- D. Based on the accepted gradation results, the Contractor will determine blend percentages in accordance with the contract specifications (see Section 401/403 – 3.2 JOB MIX FORMULA under Table 4) for each aggregate to be used in determining the Job Mix Formula, as well as mix temperature and asphalt content(s), and number of Marshall Blows for preparation of the Marshall Mix Design or number of gyrations for Superpave Mix Design, depending on which design is specified in the contract. The Contractor will verify the aggregate percentages, mix temperatures, asphalt content(s), and number of Marshall blows (or gyrations) with the IDA Engineer of Construction & Materials before beginning any testing.
- E. After verification of the information from step D., the Contractor shall make specimens and perform the following tests at various asphalt contents in order to obtain the optimum mix design. [Note: Actual test designation is referenced in Appendix B of this memorandum.]

Marshall Tests

Maximum Specific Gravity -- " G_{mm} "

Bulk Specific Gravity -- " G_{sb} "

Marshall Stability

Marshall Flow

% air voids

The JMF will be designed in accordance with Table 2 as modified in Section 401 – 3.2 or 403 – 3.2, depending on the type of mix being produced. Appendix C contains a copy of the Table 2 targets and ranges for the JMF.

- F. All technicians who will be performing mix design testing and plant sampling/testing shall have successfully completed the IDOT Division of Highways HMA Concrete Level 1 Technician Course "HMA Concrete Testing". The Contractor may also provide a Gradation Technician who has successfully completed the Department's "Gradation Technician Course" to run gradation tests only under the supervision of a HMA Concrete Level 2 Technician.
- G. The mix design testing results and resulting optimal JMF shall be reported to the IDA Engineer of Construction & Materials with the following data included:
- Aggregate & liquid asphalt material codes
 - Aggregate & liquid asphalt producer numbers, names, and locations
 - Aggregate Blend of each aggregate
 - Optimum Blend % for each sieve
 - AC Specific Gravity
 - Bulk Specific Gravity and Absorption for each aggregate

- g) Summary of Marshall Design Data: AC % Mix, Stability, Flow, G_{mb} , G_{mm} , VMA, Voids (Total Mix), Voids Filled
- h) Optimum design data listing AC % Mix, Stability, Flow, G_{mb} , G_{mm} , VMA, Voids (Total Mix), Voids Filled
- i) Percent of asphalt that any RAP will add to the mix
- j) Graphs for the following: gradation on 0.45 Power Curve, AC vs. Voids (Total Mix), AC vs. Specific Gravities, AC vs. Voids Filled, AC vs. Stability, AC vs. Flow and VMA

- H. The IDA Engineer of Construction & Materials shall generate and issue a concurrence or rejection of the Contractor's proposed Mix Design with the JMF for the manufacture of HMA mixtures based upon the Contractor's submitted testing and complete mix design results. The Contractor shall not be permitted to use the proposed HMA mix in production for the project until this concurrence letter is issued to the Contractor by the IDA Engineer of Construction & Materials, and the mix passes all test section requirements, when a test section is specified.
- I. The above procedure, III. MIX DESIGN SUBMITTAL shall be repeated for each change in source or gradation of materials.

IV. MIX PRODUCTION TESTING

The Quality Control of the manufacture and placement of HMA mixtures is the responsibility of the Contractor. The Contractor shall perform or have performed the inspection and tests required to assure conformance to contract requirements. Quality Control includes the recognition of defects and their immediate correction. This may require increased testing, communication of test results to the plant or the job site, modification of operations, suspension of HMA mix production, rejection of material, or other actions as appropriate. The Resident Engineer shall be immediately notified of any failing tests and subsequent remedial action. Form AER M-14 shall be reported to the Engineer and Resident Engineer no later than the start of the next work day. In addition, AER M-9 and M-11 shall be given to the Resident Engineer daily. The Contractor shall provide a Quality Control (QC) Manager who will have overall responsibility and authority for Quality Control. This individual shall have successfully completed the IDOT Division of Highways HMA Concrete Level II Technician Course "HMA Concrete Proportioning and Mixture Evaluation." In addition to the QC Manager, the Contractor shall provide sufficient and qualified personnel to perform the required visual inspections, sampling, testing, and documentation in a timely manner. The following plant tests and documentation shall be required: [Note: A summary chart of testing can be found in Appendix B.]

- A. Minimum of one (1) complete hot bin or combined belt analysis per day of production or every 1,000 tons, whichever is more frequent.
- B. Minimum one (1) stockpile gradation for each aggregate and/or mineral filler per week when a batch plant is utilized. Minimum of one (1) gradation for each aggregate per day of production or every 1,000 tons when a drum plant is used, and one (1) gradation per week for mineral filler when a drum plant is used.
- C. A certification from the quarry for the total quantity of aggregate listing the source, gradation type, and quality designation of aggregate shipped.
- D. Original asphalt shipping tickets listing the source and type of asphalt shipped.
- E. One mix sample per 1,000 tons of mix. The sample shall be split in half. One half shall be reserved for testing by the Engineer. The other half shall be split and tested by the Contractor for Marshall, Extraction, Gradation, Maximum Specific Gravity, and Air Void tests in accordance with the appropriate ASTM standard referenced herein. [See Appendix B.]
 - 1. In place of the extraction test, the Contractor may provide the asphalt content by a calibrated ignition oven test using the IDOT Division of Highways' latest procedure. The

correction (calibration) factor for aggregate type shall be clearly indicated in the reported test results.

From these tests, the Contractor shall interpret the test data and make necessary adjustments to the production process in order to comply with the approved JMF.

V. QUALITY CONTROL

A. Control Limits

Target values shall be determined from the approved JMF. The target values shall be plotted on the control charts within the following control limits:

<u>Parameter</u>	<u>Control Limits</u>	
	<u>Individual Test</u>	<u>Moving Avg. of 4</u>
% Passing		
1/2 in.	± 7 %	± 4 %
No. 4	± 7 %	± 4 %
No. 8	± 5 %	± 3 %
No. 30	± 4 %	± 2.5 %
No. 200 *	± 2.0 % *	± 1.0 % *
Asphalt Content	± 0.45 %	± 0.2 %

* No. 200 material percents shall be based on washed samples. Dry sieve gradations (-200) shall be adjusted based on anticipated degradation in the mixing process.

B. Control Charts

Standardized control charts shall be maintained by the Contractor at the field laboratory. The control charts shall be displayed and be accessible at the field laboratory at all times for review by the Engineer. The individual required test results obtained by the Contractor shall be recorded on the control chart immediately upon completion of a test, but no later than 24 hours after sampling. Only the required plant tests and resamples shall be recorded on the control chart. Any additional testing of check samples may be used for controlling the Contractor's processes, but shall be documented in the plant diary.

The results of assurance tests performed by the Resident Engineer will be posted as soon as available.

The following parameters shall be recorded on control charts:

1. Combined Gradation of Hot-Bin or Combined Belt Aggregate Samples (Drier Drum). (% Passing 1/2 in., No. 4., No. 8, No. 30, and No. 200 Sieves)
2. Asphalt Content
3. Bulk Specific Gravity of Marshall Sample
4. Maximum Specific Gravity of Mixture

C. Corrective Action for Required Plant Tests

Control Limits for each required parameter, both individual tests and the average of four tests, shall be exhibited on control charts. Test results shall be posted within the time limits previously outlined.

1. Individual Test Result. When an individual test result exceeds its control limit, the Contractor shall immediately resample and retest. If at the end of the day no material remains from which to resample, the first sample taken the following day shall serve as the resample as well as the first sample of the day. This result shall be recorded as a retest. If the retest passes, the Contractor may continue the required plant test frequency. Additional check samples should be taken to verify mix compliance.
2. Asphalt Content. If the retest for asphalt content exceeds control limits, mix production shall cease and immediate corrective action shall be instituted by the Contractor. After corrective action, mix production shall be restarted, the mix production shall be stabilized, and the Contractor shall immediately resample and retest. Mix production may continue when approved by the Engineer. The corrective action shall be documented.

Inability to control mix production is cause for the Engineer to stop the operation until the Contractor completes the investigation identifying the problems causing failing test results.

3. Combined Aggregate/Hot-Bin. For combined aggregate/hot-bin retest failures, immediate corrective action shall be instituted by the Contractor. After corrective action, the Contractor shall immediately resample and retest. The corrective action shall be documented.

- a. Moving Average. When the moving average values trend toward the moving average control limits, the Contractor shall take corrective action and increase the sampling and testing frequency. The corrective action shall be documented.

The Contractor shall notify the Engineer whenever the moving average values exceed the moving average control limits. If two consecutive moving average values fall outside the moving average control limits, the Contractor shall cease operations. Corrective action shall be immediately instituted by the Contractor. Operations shall not be reinstated without the approval of the Engineer. Failure to cease operations shall subject all subsequently produced material to be considered unacceptable.

- b. Mix Production Control. If the Contractor is not controlling the production process and is making no effort to take corrective action, the operation shall stop.

VI. TEST SECTION AND DENSITY ACCEPTANCE **(Note: Applies only when specified.)**

- A. The purpose of the test section is to determine if the mix is acceptable and can be compacted to a consistent passing density.

A quick way to determine the compactibility of the mix is by the use of a nuclear density gauge in the construction of a growth curve. An easy way to construct a growth curve is to use a good vibratory roller. To construct the curve, an area the width of the roller in the middle of the mat is chosen and the roller is allowed to make one compactive pass. With the roller stopped some 30 feet away, a nuclear reading is taken and the outline of the gauge is marked on the pavement. The roller then makes a compactive pass in the opposite direction and another reading is taken. This scenario is continued until at least two (2) passes are made past the maximum peak density obtained.

The maximum laboratory density potential of a given mix is a direct function of the mix design air voids. Whereas, the actual maximum field density is a function of the type of coarse aggregates, natural or manufactured sands, lift thickness, roller type (static or vibratory), roller and paver speed, base condition, mix variation, etc. All of these items are taken into consideration with the growth curve.

1. High Density in the Growth Curve. If the growth curve indicates a maximum achievable field density of between 95 to 98 percent of the Theoretical Maximum Density (D), you can proceed with the Rolling Pattern. On the other hand, if the maximum achievable density is greater than 98 percent, a quick evaluation (by use of an extractor, hot bin gradations, nuclear asphalt determinator, etc.) must be made of the mix. When adjustments are made in the mix, a new growth curve shall be constructed.
2. Low Density in the Growth Curve. If the growth curve indicates the maximum achievable density is below 94 percent, a thorough evaluation of the mix, rollers, and laydown operations should be made. After a thorough evaluation of all factors (mix, rollers, etc.), asphalt or gradation changes may be in order as directed by the Engineer. Again, any changes in the mix will require a new growth curve. Note that the nuclear density test is a quality control tool and not an acceptance test. All acceptance testing is to be conducted by the use of cores, unless otherwise specified.
3. Acceptance of Test Section. The Contractor may proceed with paving the day after the test section provided the following criteria have been met:
 - a. Four random locations (2 cores per location cut longitudinally and cored by the Contractor) will be selected by the Engineer within the test strip. No individual core can be below a minimum of 94% density.
 - b. All Marshall and extraction test results from mix produced for the test section must be within the tolerances required by specification.
 - c. The Contractor shall correlate his nuclear gauge to the cores taken in the test section. Additional cores may be taken at the Contractor's expense for this purpose within the test section area, when approved by the Engineer.
4. Density Acceptance under Production Paving. The responsibility for obtaining the specified density lies with the Contractor. Therefore, it is important that the nuclear density gauge operator communicate with the roller operators to maintain the specified density requirements. The Contractor shall provide a qualified HMA Density Tester who has successfully completed the Department's "HMA Concrete Nuclear Density Testing Course" to run all required density tests on the job site. Density acceptance testing, unless otherwise specified, is described as follows:
 - a. The Contractor shall cut cores at random locations within 500 ton sublots as directed by the Resident Engineer.
 - b. The cores should be extracted so as not to damage them, since they are used to calculate the Contractor's pay.
 - c. The Resident Engineer will run preliminary G_{mb} tests on the cores to give the Contractor an indication of how compaction is running for the next day's paving.

- d. A running average of four (4) Maximum Theoretical Gravities (G_{mm}) will be used for calculating percent compaction.
- e. Final core density tests and pay calculations will be performed by the Resident Engineer and delivered to the Contractor.

Steven J. Long, P.E.
Acting Chief Engineer

Supersedes Policy Memorandum 96-2 dated January 16, 2007.

APPENDIX A

BITUMINOUS WORKSHEET

Airport: _____ Project No.: _____ AIP No.: _____

Mix Design #: _____ Material Code: _____ Producer: _____
Prod. #: _____

AGGREGATE

Mat'l. Code: _____

Producer #: _____

Prod. Name _____

Location: _____

Percent Passing

Sieve Size

1 inch _____

3/4 inch _____

1/2 inch _____

3/8 inch _____

No. 4 _____

No. 8 _____

No. 16 _____

No. 30 _____

No. 50 _____

No. 100 _____

No. 200 _____

Washed (y/n) _____

O.D. Gravity _____

App. Gravity _____

Absorption _____

Asphalt Gravity _____ Asphalt Source _____ Asphalt Producer No. _____

MARSHALL DATA

% Asphalt _____

M. Stability _____

Flow _____

D _____

d _____

% Air Voids _____

Q.C. Manager Name: _____ Phone number: _____

Laboratory Location: _____ Fax Number: _____

Remarks: _____

APPENDIX B

QUALITY CONTROL TESTING (PLANT)

PARAMETER	FREQUENCY	SAMPLE SIZE	TEST METHOD	REPORT FORM
Aggregate Gradations: Hot bins for batch and continuous plants--- Individual cold-feeds or combined belt-feeds for drier drum plants.	Minimum 1 per day of production and at least 1 per 1000 tons.	CA07/11: 5000 gm CA13: 2000 gm CA16: 1500 gm Fine agg: 500 gm 1 gallon asphalt cement	ASTM C 136	AER M-9
Aggregate gradations: Stockpiles	Minimum 1 per aggregate per week per stockpile.	CA07/11: 5000 gm CA13: 2000 gm CA16: 1500 gm Fine agg: 500 gm *Note: The above test sample sizes are to be obtained from splitting down a larger sample from the stockpiles.	ASTM C 136	AER M-9
Maximum Specific Gravity	Minimum 1 per 1000 tons	1200 gm per test	ASTM D 2041	AER M-11 and AERM-14
Bulk Specific Gravity	Minimum 1 per 1000 tons	1250 gm per briquette	ASTM D 2726	AER M-11 and AERM-14
Marshall Stability and Flow	Minimum 1 per 1000 tons	1250 gm per briquette	ASTM D 1559	AER M-11 and AERM-14
% Air Voids	Minimum 1 per 1000 tons		ASTM D 3203	AER M-11 and AERM-14
Extraction	Minimum 1 per 1000 tons	1000 gm (surface) 1500 gm (base)	ASTM D 2172	AER M-11 and AERM-14
Ignition Oven Test	Minimum 1 per 1000 tons	1500 gm		AER M-14
Nuclear Asphalt Gauge	Minimum 1 per 1000 tons	1000-1100 gm	ASTM D 2145	AER M-14

MIX DESIGN TESTING

PARAMETER	FREQUENCY	SAMPLE SIZE	TEST METHOD	REPORT FORM
Representative samples of each aggregate and asphalt cement.	1 per aggregate and 1 asphalt cement.	280 lb. (coarse) 150 lb. (fine) 15 lb. (min. filler) 1 gallon asphalt cement	ASTM D 75	N/A
Aggregate Gradation	1 per aggregate	CA07/11: 5000 gm CA13: 2000 gm CA16: 1500 gm Fine agg: 500 gm	ASTM C 136	Bituminous Worksheet (Appendix A)
Maximum Specific Gravity	2 per specified asphalt content	1200 gm per test	ASTM D 2041	Bituminous Worksheet (Appendix A)
Bulk Specific Gravity	3 briquettes per specified asphalt content	1250 gm per briquette	ASTM D 2726	Bituminous Worksheet (Appendix A)
Marshall Stability and Flow	3 briquettes	1250 gm per briquette	ASTM D 1559	Bituminous Worksheet (Appendix A)
% Air Voids	1 per specified asphalt content (Avg. of G_{sb}/G_{mm})		ASTM D 3203	Bituminous Worksheet (Appendix A)

QUALITY CONTROL TESTING (PAVER)

PARAMETER	FREQUENCY	SAMPLE SIZE	TEST METHOD	REPORT FORM
Nuclear Density Test	As required by the Contractor to amintain consistent passing density	Various locations	ASTM D 2950	

APPENDIX C

AGGREGATE HMA BASE COURSE

Percentage by Weight Passing Sieves Job Mix Formula (JMF)		
Sieve Size	Gradation B Range 1" Maximum	Ideal Target
1-1/4 in.	---	---
1 in.	100	100
3/4 in.	93 – 97	95
1/2 in.	75 – 79	77
3/8 in.	64 – 68	66
No. 4	45 – 51	48
No. 8	34 – 40	37
No. 16	27 – 33	30
No. 30	19 – 23	21
No. 100	6 – 10	8
No. 200	4 – 6	5
Bitumen %:		
Stone	4.5 – 7.0	5.5

AGGREGATE HMA SURFACE COURSE

Percentage by Weight Passing Sieves Job Mix Formula (JMF)		
Sieve Size	Gradation B Range ³/₄" Maximum	Ideal Target
1 in.	100	---
3/4 in.	100	100
1/2 in.	99 - 100	100
3/8 in.	91 - 97	94
No. 4	56 - 62	59
No. 8	36 - 42	39
No. 16	27 - 32	30
No. 30	19 - 25	22
No. 100	7 - 9	8
No. 200	5 - 7	6
Bitumen %: Stone	5.0 - 7.0	6.0

State of Illinois
Department of Transportation
Division of Aeronautics

POLICY MEMORANDUM

January 1, 2004

Springfield, Illinois

Number 96-3

TO: CONSULTING ENGINEERS

SUBJECT: REQUIREMENTS FOR QUALITY ASSURANCE ON PROJECTS
WITH BITUMINOUS CONCRETE PAVING

I. SCOPE

The purpose of this policy memorandum is to define to the Consulting Engineer the requirements concerning Quality Assurance on bituminous concrete paving projects. Specifically, this memo applies whenever the Contractor is required to comply with the requirements set forth in Policy Memorandum 96-2, "*Requirements for Laboratory, Testing, Quality Control, and Paving of Bituminous Concrete Mixtures*".

II. LABORATORY APPROVAL

The Resident Engineer shall review and approve the Contractor's plant laboratory to assure that it meets the requirements set forth in the contract specifications and Policy Memorandum 96-2. This review and approval shall be completed prior to utilization of the plant for the production of any mix.

III. QUALITY ASSURANCE DURING PRODUCTION PAVING

A. At the option of the Engineer, independent assurance tests may be performed on split samples taken by the Contractor for Quality Control testing. In addition, the Resident Engineer shall witness the sampling and splitting of these samples at the start of production and as needed throughout mix production. The Engineer may select any or all split samples for assurance testing. These tests may be performed at any time after sampling. The test results will be made available to the Contractor as soon as they become available.

B. The Resident Engineer may witness the sampling and testing being performed by the Contractor. If the Resident Engineer determines that the sampling and Quality Control tests are not being performed according to the applicable test procedures, the Engineer may stop production until corrective action is taken. The Resident Engineer will promptly notify the Contractor, both verbally and in writing, of observed deficiencies. The Resident Engineer will document all witnessed samples and tests. The Resident Engineer may elect to obtain samples for testing, separate from the Contractor's Quality Control process, to verify specification compliance.

1. Differences between the Contractor's and the Engineer's split sample test results will be considered acceptable if within the following limits:

<u>Test Parameter</u>	<u>Acceptable Limits of Precision</u>
% Passing	
1/2 in.	5.0 %
No. 4	5.0 %
No. 8	3.0 %
No. 30	2.0 %
No. 200	2.2 %
Asphalt Content	0.3 %
Maximum Specific Gravity of Mixture	0.026
Bulk Specific Gravity of Marshall Sample	0.045

2. In the event a comparison of the required plant test results is outside the above acceptable limits of precision, split or independent samples fail the control limits, an extraction indicates non-specification mix, or a continual trend of difference between Contractor and Engineer test results is identified, the Engineer will immediately investigate. The Engineer may suspend production while the investigation is in progress. The investigation may include testing by the Engineer of any remaining split samples or a comparison of split sample test results on the mix currently being produced. The investigation may also include review and observation of the Contractor's technician performance, testing procedure, and equipment. If a problem is identified with the mix, the Contractor shall take immediate corrective action. After corrective action, both the Contractor and the Engineer shall immediately resample and retest.

- C. The Contractor shall be responsible for documenting all observations, records of inspection, adjustments to the mixture, test results, retest results, and corrective actions in a bound hardback field book or bound diary which will become the property of IDA upon completion and acceptance of the project. The Contractor shall be responsible for the maintenance of all permanent records whether obtained by the Contractor, the Contractor's Consultants, or the producer of bituminous mix material. The Contractor shall provide the Engineer full access to all documentation throughout the progress of the work.

Results of adjustments to mixture production and tests shall be recorded in duplicate and sent to the Engineer.

IV. ACCEPTANCE BY ENGINEER

Density acceptance shall be performed according to Policy Memorandum 87-2, or according to the acceptance procedure outlined in the Special Provisions.

Steven J. Long, P.E.
Acting Chief Engineer

Supersedes Policy Memorandum 96-3 dated January 1, 1997

State of Illinois
Department of Transportation
Division of Aeronautics

POLICY MEMORANDUM

January 1, 2004

Springfield, Illinois

Number 97-2

TO: CONSULTING ENGINEERS

SUBJECT: PAVEMENT MARKING PAINT ACCEPTANCE

I. SCOPE

The purpose of this policy memorandum is to define the procedure for acceptance of pavement marking paint.

II. RESIDENT ENGINEER'S DUTIES

The Resident Engineer shall follow the acceptance procedure outlined as follows:

- A. Require the painting contractor to furnish the name of the paint manufacturer and the batch number proposed for use prior to beginning work. Notify the I.D.A. Materials Certification Engineer when this information is available.
- B. Require the manufacturer's certification before painting begins. Check the certification for compliance to the contract specifications.
 1. The certification shall be issued from the manufacturer and shall include the specification and the batch number.
 2. The paint containers shall have the manufacturer's name, the specification and the batch number matching the certification.
- C. If no batch number is indicated on the certification or containers, sample the paint according to the procedure for the corresponding paint type.
- D. If the I.D.A. Engineer of Materials indicates that batch number has not been previously sampled and tested, sample the paint according to the procedure for the corresponding paint type. The Division of Aeronautics will provide paint cans upon request by the Resident Engineer. Samples will only be taken in new epoxy lined cans so that the paint will not be contaminated. It is important to seal the sample container immediately with a tight cover to prevent the loss of volatile solvents.

Mark the sample cans with the paint color, manufacturer's name, and batch number. The paint samples and manufacturer's certification shall be placed in the mail within 24 hours after sampling. Address the samples to the Materials Certification Engineer at:

Illinois Department of Transportation
Division of Aeronautics
One Langhorne Bond Drive
Springfield, Illinois 62707

Sampling Procedures for Each Paint Type:

1. Waterborne or Solvent Base Paints
 - a. Take the paint sample from the spray nozzle when the contractor begins marking. A sample consists of two one-pint cans taken per batch number.
 - b. Be sure to indicate to the contractor that acceptance of material is based upon a passing test of the paint material.

2. Epoxy Paint
 - a. Take separate one-pint samples of each paint component prior to marking. Before drawing samples, the contents of each component's container must be thoroughly mixed to make certain that any settled portion is fully dispersed. **Do not combine the two components or sample from the spray nozzle.**
 - b. Be sure to indicate to the contractor that acceptance of material is based upon a passing test of the paint material.

III. TESTING

The paint will be tested for acceptance by the IDOT Bureau of Materials and Physical Research for conformance to the contract specifications.

Steven J. Long, P.E.
Acting Chief Engineer

Supersedes policy memorandum 97-2 dated February 27, 2002

State of Illinois
Department of Transportation
Division of Aeronautics

POLICY MEMORANDUM

January 1, 2004	Springfield, Illinois	Number: 2001-1
-----------------	-----------------------	----------------

TO: CONTRACTORS

SUBJECT: REQUIREMENTS FOR COLD WEATHER CONCRETING

I. PURPOSE

- A. This policy memorandum outlines the minimum requirements for cold weather concreting. Cold weather is defined as whenever the average ambient air temperature during day or night drops below 40°F.

II. COLD WEATHER CONCRETING PLAN

- A. The contractor shall submit a cold weather concreting plan to the Engineer for approval. Cold weather concreting operations are not allowed to proceed until the contractor's cold weather concreting plan has been approved by the Engineer.
- B. The contractor's plan shall be in compliance with this memorandum and shall address, as a minimum, the following:
1. Concrete Mix Manufacturing
 2. Concrete Mix Temperature Monitoring
 3. Base Preparation
 4. Concrete Curing and Protection
 5. In Place Concrete Temperature Monitoring
 6. Strength Test Specimens

III. MINIMUM REQUIREMENTS

A. Concrete Mix Manufacturing

1. The contractor must make the necessary adjustments so that the concrete temperature is maintained from 50°F to 90°F for placement. Acceptable methods include:
 - a) Heating the mixing water Note: If the mixing water is to be heated to a temperature above 100°F, the contractor must include a mixing sequence plan to indicate the order that each component of the mix is to be charged into the mixer.

- b) Heating the aggregates Note: The exact method of heating the aggregates shall be included as part of the cold weather concreting plan. Aggregates must be free of ice and frozen lumps. To avoid the possibility of a quick or flash set of the concrete, when either the water or aggregates are heated to above 100°F, they should be combined in the mixer first before the cement is added.

B. Concrete Mix Temperature

1. The contractor shall monitor the mix temperature at the plant and prior to placement in the forms. Mix that does not meet the temperature requirement of 50°F to 90°F shall be rejected for use on the project.

C. Base Preparation

1. Paving or placing concrete on a frozen base, subbase, or subgrade is prohibited.
2. The base, subbase, or subgrade on which the concrete is to be placed shall be thawed and heated to at least 40°F. The method by which the base subbase or subgrade is to be heated shall be indicated in the contractor's cold weather concreting plan. Insulating blankets or heated enclosures may be required.

D. Concrete Protection and Curing

1. In addition to the curing options available in article 501-3.17 (a) (b), (c), and (d) of the Standard Specifications for Construction of Airports, the contractor shall protect the concrete in such a manner as to maintain a concrete temperature of at least 50°F for 10 days.
2. The method of concrete protection shall be by use of insulating layer or heated enclosure around the concrete. The method of protection shall be indicated in the contractor's cold weather concreting plan. When insulating layers are to be used, the thermal resistance to heat transfer (R Value in °F*hr*ft²/BTU) of the insulation material selected, shall be appropriate for the slab thickness being constructed and shall be indicated in the cold weather concreting plan.
3. Appendix A shows a chart and table taken from the American Concrete Institute specification, ACI 306 R Cold Weather Concreting, which may be used by the contractor in selecting the proper insulation (R Value) and insulating material which may be used.

E. In-Place Concrete Temperature Monitoring

1. Once the concrete is in place, the protection method used, must ensure that the concrete temperature does not fall below 50°F for the time period specified in Section (D. 1.) of this Policy Memorandum (10 days).
2. The concrete temperature on the surface and below the surface must be monitored and recorded by the contractor for the duration of the protection period in Section (D. 1.).
3. After the concrete has hardened, surface temperature can be checked with special surface thermometers or with an ordinary thermometer that is kept covered with insulating blankets. The high and low values for each 24-hour period of protection must be measured and recorded.
4. One acceptable method of checking temperature below the concrete surface is given in the Portland Cement Association (PCA) book entitled "Design and Control of Concrete Mixtures" latest edition. The method is indicated below and it should be noted that the thermometer should be capable of recording high and low values for a given 24-hour period.

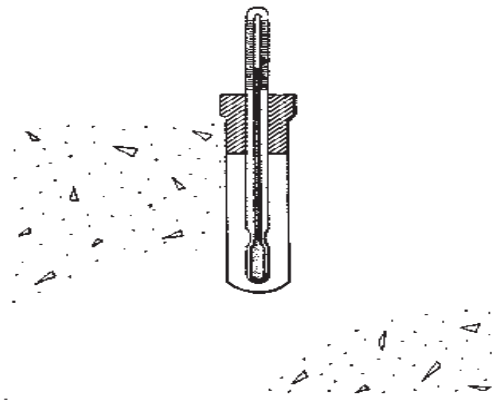

5. The exact method for surface and sub-surface concrete temperature monitoring shall be indicated in the contractor's cold weather concreting plan. The maximum permissible difference between the interior and surface temperature is 35 °F. Adjustments in protection method shall be implemented if the maximum permissible difference is exceeded.

F. Strength specimen handling

1. The Contractor is responsible for making, transporting, and curing all samples (beams or cylinders)
2. The Contractor is required to load the testing machine and dispose of the broken pieces.
3. Onsite, indoor curing facilities, meeting the requirements of ASTM C-31, shall be required for cold weather concreting operations.

4. Sampling for strength specimens shall be according to the Contract Special Provisions. Sampled concrete shall be transported to the indoor curing facilities for the casting of strength specimens.
5. The exact location and description of the curing facilities shall be indicated in the contractor's cold weather concreting plan.
6. The method of transporting concrete sampled from the grade to the curing facilities for casting shall be indicated in the contractor's cold weather concreting plan.

Steven J. Long, P.E.
Acting Chief Engineer

Supersedes Policy Memorandum 2001-1 dated January 1, 2001

APPENDIX A

Minimum exposure temperatures for concrete flatwork placed on the ground for concrete placed & surface temperature maintained at 50 F (10 C) for 3 days on ground at 35 F (2 C)

Slab thickness, in. (m)	Minimum ambient air temperature, deg F (deg C) allowable when insulation having these values of thermal resistance R, hr-ft ² -F/Btu (m ² -K/W), is used			
	R = 2 (0.35)	R = 4 (0.70)	R = 6 (1.06)	R = 8 (1.41)
Cement content = 300 lb/yd ² (178 kg/m ²)				
4 (0.10)	*	*	*	*
8 (0.20)	*	*	*	*
12 (0.31)	*	*	*	*
18 (0.46)	42 (6)	38 (3)	32 (0)	26 (-3)
24 (0.61)	37 (3)	25 (-4)	11 (-12)	-3 (-19)
30 (0.76)	31 (-1)	15 (-9)	-1 (-18)	-17 (-27)
36 (0.91)	31 (-1)	12 (-11)	-5 (-21)	-22 (-30)
Cement content = 400 lb/yd ² (237 kg/m ²)				
4 (0.10)	*	*	*	*
8 (0.20)	*	*	*	*
12 (0.31)	46 (8)	44 (7)	42 (6)	40 (4)
18 (0.46)	36 (2)	22 (-6)	8 (-13)	-6 (-21)
24 (0.61)	28 (-2)	9 (-13)	-10 (-23)	-29 (-34)
30 (0.76)	21 (-6)	0 (-18)	-21 (-29)	-42 (-41)
36 (0.91)	21 (-6)	-4 (-20)	-29 (-34)	-50 (-46)
Cement content = 500 lb/yd ² (296 kg/m ²)				
4 (0.10)	*	*	*	*
8 (0.20)	*	*	*	*
12 (0.31)	42 (6)	36 (2)	30 (-1)	24 (-4)
18 (0.46)	30 (-1)	12 (-11)	-6 (-21)	-22 (-30)
24 (0.61)	21 (-6)	-5 (-21)	-31 (-35)	-50 (-46)
30 (0.76)	16 (-9)	-10 (-23)	-42 (-41)	-74 (-59)
36 (0.91)	16 (-9)	-18 (-28)	-50 (-46)	#
Cement content = 600 lb/yd ² (356 kg/m ²)				
4 (0.10)	*	*	*	*
8 (0.20)	*	*	*	*
12 (0.31)	38 (3)	26 (-3)	14 (-10)	2 (-17)
18 (0.46)	24 (-4)	0 (-18)	-24 (-31)	-48 (-44)
24 (0.61)	14 (-10)	-16 (-27)	-46 (-43)	-82 (-63)
30 (0.76)	10 (-12)	-20 (-29)	-62 (-52)	#
36 (0.91)	7 (-14)	-30 (-34)	#	#

* > 50 F (10 C): additional heat required

<< -60 F (-51 C)

Minimum exposure temperatures for concrete flatwork placed on the ground for concrete placed & surface temperature maintained at 50 F (10 C) for 7 days on ground at 35 F (2 C)

Slab thickness, in. (m)	Minimum ambient air temperature, deg F (deg C) allowable when insulation having these values of thermal resistance R, hr-ft ² -F/Btu (m ² -K/W), is used			
	R = 2 (0.35)	R = 4 (0.70)	R = 6 (1.06)	R = 8 (1.41)
Cement content = 300 lb/yd ² (178 kg/m ²)				
4 (0.10)	*	*	*	*
8 (0.20)	*	*	*	*
12 (0.31)	*	*	*	*
18 (0.46)	46 (8)	42 (6)	36 (2)	30 (-1)
24 (0.61)	40 (4)	31 (-1)	22 (-6)	11 (-12)
30 (0.76)	35 (2)	22 (-6)	7 (-14)	-8 (-22)
36 (0.91)	31 (-1)	13 (-11)	-5 (-21)	-23 (-31)
Cement content = 400 lb/yd ² (237 kg/m ²)				
4 (0.10)	*	*	*	*
8 (0.20)	*	*	*	*
12 (0.31)	*	*	*	*
18 (0.46)	41 (5)	32 (0)	22 (-6)	12 (-11)
24 (0.61)	35 (2)	19 (-7)	-1 (-17)	-15 (-26)
30 (0.76)	28 (-2)	8 (-13)	-14 (-26)	-36 (-38)
36 (0.91)	23 (-5)	-4 (-20)	-29 (-34)	-54 (-48)
Cement content = 500 lb/yd ² (296 kg/m ²)				
4 (0.10)	*	*	*	*
8 (0.20)	*	*	*	*
12 (0.31)	48 (9)	44 (7)	40 (4)	36 (2)
18 (0.46)	36 (2)	22 (-6)	8 (-13)	-6 (-21)
24 (0.61)	28 (-2)	6 (-14)	-16 (-27)	-38 (-39)
30 (0.76)	22 (-6)	-7 (-22)	-36 (-38)	-64 (-53)
36 (0.91)	16 (-9)	-18 (-28)	-50 (-46)	#
Cement content = 600 lb/yd ² (356 kg/m ²)				
4 (0.10)	*	*	*	*
8 (0.20)	*	*	*	*
12 (0.31)	44 (7)	38 (3)	32 (0)	26 (-3)
18 (0.46)	31 (-1)	14 (-10)	-5 (-21)	-24 (-31)
24 (0.61)	22 (-6)	-5 (-21)	-32 (-36)	-61 (-52)
30 (0.76)	14 (-10)	-19 (-28)	-67 (-55)	#
36 (0.91)	7 (-14)	-30 (-34)	#	#

* > 50 F (10 C): additional heat required

< -60 F (-51 C)

Thermal Resistance of Various Insulating Materials

Insulating Material	Thermal resistance "R" for these thicknesses of material*	
	1 in., hr·ft ³ ·F / Btu	10 mm, m ³ ·K / W
Boards and slabs		
Expanded polyurethane (R-11 exp.)	6.25	0.438
Expanded polystyrene extruded (R-11 exp.)	5	0.347
Expanded polystyrene extruded, plain	4	0.277
Glass fiber, organic bonded	4	0.277
Expanded polystyrene, molded beads	3.57	0.247
Mineral fiber with resin binder	3.45	0.239
Mineral fiber board, wet felted	2.94	0.204
Sheathing, regular density	2.63	0.182
Cellular glass	2.63	0.182
Laminated paperboard	2	0.139
Particle board (low density)	1.85	0.128
Plywood	1.25	0.087
Blanket		
Mineral fiber, fibrous form processed from rock, slag, or glass	3.23	0.224
Loose fill		
Wood fiber, soft woods	3.33	0.231
Mineral fiber (rock, slag, or glass)	2.5	0.173
Perlite (expanded)	2.7	0.187
Vermiculite (exfoliated)	2.2	0.152
Sawdust or shavings	2.22	0.154

*Values from ASHRAE Handbook of Fundamentals, 1977, American Society of Heating, Refrigerating, and Air-Conditioning Engineers, New York.

State of Illinois
Department of Transportation
Division of Aeronautics

POLICY MEMORANDUM

April 1, 2010

Springfield, Illinois

Number 2003-1

TO: CONTRACTORS

SUBJECT: REQUIREMENTS FOR LABORATORY, TESTING, QUALITY CONTROL, AND PAVING OF SUPERPAVE HMA CONCRETE MIXTURES FOR AIRPORTS

I. SCOPE

The purpose of this policy memorandum is to define to the Contractor the requirements concerning the laboratory, testing, Quality Control, and paving of HMA mixtures utilizing Superpave technology. References are made to the most recent issue of the Standard Specifications for Construction of Airports and to American Society for Testing and Materials (ASTM) testing methods. The Quality Assurance and acceptance responsibilities of the Resident Engineer are described in Policy Memorandum 96-3.

II. LABORATORY

The Contractor shall provide a laboratory located at the plant and approved by the Illinois Division of Aeronautics (IDA). The laboratory shall be of sufficient size and be furnished with the necessary equipment and supplies for adequately and safely performing the Contractor's Quality Control testing as well as the Resident Engineer's acceptance testing as described in Policy Memorandum 96-3.

The effective working area of the laboratory shall be a minimum of 600 square feet with a ceiling height of not less than 7.5 feet. Lighting shall be adequate to illuminate all working areas. It shall be equipped with heating and air conditioning units to maintain a temperature of 70° F ±5°F.

The laboratory shall have equipment that is in good working order and that meets the requirements set forth in the following ASTM test standards:

ASTM D 70	Test Method for Specific Gravity and Density of Semi-Solid Materials
ASTM C 117	Test Method for Materials Finer than 75 µm (No. 200) Sieve in Mineral Aggregates by Washing
ASTM C 136	Sieve or Screen Analysis of Fine and Coarse Aggregate
ASTM C 566	Total Moisture Content of Aggregate by Drying
ASTM D 75	Sampling Aggregates
ASTM D 2041	Theoretical Maximum Specific Gravity and Density of Bituminous Paving Mixtures
ASTM D 2172	Quantitative Extraction of Bitumen from Bituminous Paving Mixtures
IDOT	Ignition Method for Determining Asphalt Content
ASTM D 2726	Bulk Specific Gravity of Compacted Bituminous Mixtures using Saturated Surface Dry Specimens

ASTM D 3203	Percent Air Voids in Compacted Dense and Open Bituminous Paving Mixtures
ASTM D 2950	Density of Bituminous Concrete in Place by Nuclear Method
ASTM D 4125	Asphalt Content of Bituminous Mixtures by Nuclear Method
ASTM C 127	Standard Test Method for Specific Gravity and Absorption of Coarse Aggregate
ASTM C 128	Standard Test Method for Specific Gravity and Absorption of Fine Aggregate

The Asphalt Institute's *Superpave Mix Design, Superpave Series No. 2 (SP-2)*

The laboratory and equipment furnished by the Contractor shall be properly calibrated and maintained. The Contractor shall maintain a record of calibration results at the laboratory. The Engineer may inspect measuring and testing devices at any time to confirm both calibration and condition. If the Resident Engineer determines that the equipment is not within the limits of dimensions or calibration described in the appropriate test method, he may stop production until corrective action is taken. If laboratory equipment becomes inoperable or insufficient to keep up with mix production testing, the Contractor shall cease mix production until adequate and/or sufficient equipment is provided.

III. MIX DESIGN SUBMITTAL

Based upon data and test results submitted by the Contractor, the Illinois Division of Aeronautics Engineer of Construction & Materials shall issue the final Job Mix Formula (JMF) approval letter that concurs or rejects the Contractor's proposed JMF. The Contractor will be required to perform the sampling and laboratory testing and develop a complete mix design, according to the following guidelines: [Note: A testing summary chart can be found in Appendix B.]

- A. Material sources meeting the requirements of the contract shall be submitted in writing at or before the preconstruction conference (see BITUMINOUS WORKSHEET in Appendix A) in the following format:
 1. To: Steven J. Long, P.E., Acting Chief Engineer
Attn: Michael F. Wilhelm, P.E., Engineer of Construction & Materials
Division of Aeronautics
One Langhorne Bond Drive
Springfield, Illinois 62707
 2. Producer name and location of each aggregate
 3. Producer # for each aggregate (producers are assigned this number by IDOT Central Bureau of Materials)
 4. Material code for each aggregate
 5. Gradation and Quality designation for each aggregate (i.e. CA-11, etc.)
 6. Producer, producer #, and specific gravities of asphalt cement
 7. Performance Graded Binder 64-22 shall be used unless otherwise approved by the IDA Engineer of Construction & Materials.
- B. The Contractor shall obtain representative samples of each aggregate. The individual obtaining samples shall have successfully completed the IDOT Aggregate Technician Course under the

IDOT Division of Highways, QC/QA program. The sample size shall be approximately 280 lb. for each coarse aggregate, 150 lb. for each fine aggregate, 15 lb. for the mineral filler or collected dust, and 1 gallon of asphalt cement.

- C. The Contractor shall split the aggregate samples down and run gradation tests according to the testing methods referenced in Appendix B of this memorandum. The remaining aggregates shall be set aside for further Mix Design testing. The results of the gradation tests, along with the most recent stockpile gradations, shall be reported by fax to the IDA Engineer of Construction & Materials for engineering evaluation. If the gradation results are deemed non-representative or in any way unacceptable, new representative samples may be required at the direction of the IDA Engineer of Construction & Materials. Only composite gradations are required under this procedure.
- D. Based on the accepted gradation results, the Contractor will determine blend percentages in accordance with the contract specifications (see Section 401/403 – 3.2 JOB MIX FORMULA under Table 2) for each aggregate to be used in determining the Job Mix Formula, as well as mix temperature and asphalt content(s), and number of Gyration (N_{des}) for preparation of the Superpave Mix Design. The Contractor will verify the aggregate percentages, mix temperatures, asphalt content(s), and number of gyrations with the IDA Engineer of Construction & Materials before beginning any testing.
- E. After verification of the information from step D., the Contractor shall make specimens and perform the following tests at various asphalt contents in order to obtain the optimum mix design. [Note: Actual test designation is referenced in Appendix B of this memorandum.]

Tests

Maximum Specific Gravity -- G_{mm}

Bulk Specific Gravity -- G_{mb}

% air voids -- V_a

% VMA

VFA %

The JMF will be designed in accordance with TABLE 2 as modified in Section 401 – 3.2 or 403 – 3.2, depending on the type of mix being produced. Appendix C contains a copy of the TABLE 2 targets and ranges for the JMF.

- F. All technicians who will be performing mix design testing and plant sampling/testing shall have successfully completed the IDOT Division of Highways Bituminous Concrete Level 1 Technician Course “Bituminous Concrete Testing”. The Contractor may also provide a Gradation who has successfully completed the Department’s “Gradation Technician Course” to run gradation tests only under the supervision of a Bituminous Concrete Level 2 Technician.
- G. The mix design testing results and resulting optimal JMF shall be reported to the IDA Engineer of Construction & Materials with the following data included:
 - a) Aggregate & liquid asphalt material codes
 - b) Aggregate & liquid asphalt producer numbers, names, and locations
 - c) Aggregate Blend of each aggregate
 - d) Optimum Blend % for each sieve
 - e) AC Specific Gravity
 - f) Bulk Specific Gravity and Absorption for each aggregate
 - g) Summary of Superpave Design Data: AC % Mix, G_{mb} , G_{mm} , VMA, Voids (Total Mix), Voids Filled, V_{be} , P_{be} , P_{ba} , G_{se}
 - h) Optimum design data listing: AC % Mix, G_{mb} , G_{mm} , VMA, Voids (Total Mix), Voids Filled, G_{se} , G_{sb}
 - i) Percent of asphalt that any RAP will add to the mix

j) Graphs for the following: gradation on 0.45 Power Curve, AC vs. Voids (Total Mix), AC vs. Specific Gravities, AC vs. Voids Filled, AC vs. VMA

- H. The IDA Engineer of Construction & Materials shall generate and issue a concurrence or rejection of the Contractor's proposed Mix Design with the JMF for the manufacture of HMA mixtures based upon the Contractor's submitted testing and completed mix design results. The Contractor shall not be permitted to use the proposed HMA mix in production for the project until an approval letter is issued to the Contractor by the IDA Engineer of Construction & Materials, and the mix passes all test section requirements, when a test section is specified.
- I. The above procedure, III. MIX DESIGN SUBMITTAL, shall be repeated for each change in source or gradation of materials.

IV. MIX PRODUCTION TESTING

The Quality Control of the manufacture and placement of HMA mixtures is the responsibility of the Contractor. The Contractor shall perform or have performed the inspection and tests required to assure conformance to contract requirements. Quality Control includes the recognition of defects and their immediate correction. This may require increased testing, communication of test results to the plant or the job site, modification of operations, suspension of HMA production, rejection of material, or other actions as appropriate. The Resident Engineer shall be immediately notified of any failing tests and subsequent remedial action. Form AER M-14 shall be reported to the Engineer and Resident Engineer no later than the start of the next work day. In addition, AER M-9 and M-11 shall be given to the Resident Engineer daily. The Contractor shall provide a Quality Control (QC) Manager who will have overall responsibility and authority for Quality Control. This individual shall have successfully completed the IDOT Division of Highways HMA Concrete Level II Technician Course "HMA Proportioning and Mixture Evaluation." In addition to the QC Manager, the Contractor shall provide sufficient and qualified personnel to perform the required visual inspections, sampling, testing, and documentation in a timely manner. The following plant tests and documentation shall be required: [Note: A summary chart of testing can be found in Appendix B.]

- A. Minimum of one (1) complete hot bin or combined belt analysis per day of production or every 1,000 tons, whichever is more frequent.
- B. Minimum one (1) stockpile gradation for each aggregate and/or mineral filler per week when a batch plant is utilized. Minimum of one (1) gradation for each aggregate per day of production or every 1,000 tons when a drum plant is used, and one (1) gradation per week for mineral filler when a drum plant is used.
- C. A certification from the quarry for the total quantity of aggregate listing the source, gradation type, and quality designation of aggregate shipped. In lieu of a certification, the contractor may complete and submit an "Aggregate Certification of Compliance" form which may be obtained from IDA or found on the I.D.O.T. website.
- D. Original asphalt shipping tickets listing the source and type of asphalt shipped.

- E. One mix sample per 1,000 tons of mix. The sample shall be split in half. One half shall be reserved for testing by the Engineer. The other half shall be split and tested by the Contractor for Extraction, Gradation, Maximum Specific Gravity, and Air Void tests in accordance with the appropriate ASTM standard referenced herein. [See Appendix B.]
1. In place of the extraction test, the Contractor may provide the asphalt content by a calibrated ignition oven test using the IDOT Division of Highways' latest procedure. The correction (calibration) factor for aggregate type shall be clearly indicated in the reported test results.

From these tests, the Contractor shall interpret the test data and make necessary adjustments to the production process only in order to comply with the approved JMF.

V. QUALITY CONTROL

A. Control Limits

Target values shall be determined from the approved JMF. The target values shall be plotted on the control charts within the following control limits:

<u>Parameter</u>	<u>Control Limits</u>	
	<u>Individual Test</u>	<u>Moving Avg. of 4</u>
% Passing		
1/2 in.	± 7 %	±4 %
No. 4	±7 %	±4 %
No. 8	±5 %	±3 %
No. 30	±4 %	±2.5 %
No. 200 *	±2.0 % *	±1.0 % *
Asphalt Content	±0.45 %	±0.2 %

* No. 200 material percents shall be based on washed samples. Dry sieve gradations (-200) shall be adjusted based on anticipated degradation in the mixing process.

B. Control Charts

Standardized control charts shall be maintained by the Contractor at the field laboratory. The control charts shall be displayed and be accessible at the field laboratory at all times for review by the Engineer. The individual required test results obtained by the Contractor shall be recorded on the control chart immediately upon completion of a test, but no later than 24 hours after sampling. Only the required plant tests and resamples shall be recorded on the control chart. Any additional testing of check samples may be used for controlling the Contractor's processes, but shall be documented in the plant diary.

The results of assurance tests performed by the Resident Engineer will be posted as soon as available.

The following parameters shall be recorded on control charts:

1. Combined Gradation of Hot-Bin (Batch Plant) or Combined Belt Aggregate Samples (Drier Drum Plant). (% Passing 1/2 in., No. 4., No. 8, No. 30, and No. 200 Sieves)
2. Asphalt Content

3. Bulk Specific Gravity (G_{mb})
4. Maximum Specific Gravity of Mixture (G_{mm})

C. Corrective Action for Required Plant Tests

Control Limits for each required parameter, both individual tests and the average of four tests, shall be exhibited on control charts. Test results shall be posted within the time limits previously outlined.

1. Individual Test Result. When an individual test result exceeds its control limit, the Contractor shall immediately resample and retest. If at the end of the day no material remains from which to resample, the first sample taken the following day shall serve as the resample as well as the first sample of the day. This result shall be recorded as a retest. If the retest passes, the Contractor may continue the required plant test frequency. Additional check samples should be taken to verify mix compliance.
2. Asphalt Content. If the retest for asphalt content exceeds control limits, mix production shall cease and immediate corrective action shall be instituted by the Contractor. After corrective action, mix production shall be restarted, the mix production shall be stabilized, and the Contractor shall immediately resample and retest. Mix production may continue when approved by the Engineer. The corrective action shall be documented.

Inability to control mix production is cause for the Engineer to stop the operation until the Contractor completes the investigation identifying the problems causing failing test results.

3. Combined Aggregate/Hot-Bin. For combined aggregate/hot-bin retest failures, immediate corrective action shall be instituted by the Contractor. After corrective action, the Contractor shall immediately resample and retest. The corrective action shall be documented.
 - a. Moving Average. When the moving average values trend toward the moving average control limits, the Contractor shall take corrective action and increase the sampling and testing frequency. The corrective action shall be documented.

The Contractor shall notify the Engineer whenever the moving average values exceed the moving average control limits. If two consecutive moving average values fall outside the moving average control limits, the Contractor shall cease operations. Corrective action shall be immediately instituted by the Contractor. Operations shall not be reinstated without the approval of the Engineer. Failure to cease operations shall subject all subsequently produced material to be considered unacceptable.
 - b. Mix Production Control. If the Contractor is not controlling the production process and is making no effort to take corrective action, the operation shall stop.

VI. TEST SECTION AND DENSITY ACCEPTANCE (Note: Applies only when specified.)

- A. The purpose of the test section is to determine if the mix is acceptable and can be compacted to a consistent passing density.

A quick way to determine the compactibility of the mix is by the use of a nuclear density gauge in the construction of a growth curve. An easy way to construct a growth curve is to use a good vibratory roller. To construct the curve, an area the width of the roller in the middle of the mat is chosen and the roller is allowed to make one compactive pass. With the roller stopped some 30 feet away, a nuclear reading is taken and the outline of the gauge is marked on the pavement. The roller then makes a compactive pass in the opposite direction and another reading is taken. This scenario is continued until at least two (2) passes are made past the maximum peak density obtained.

The maximum laboratory density potential of a given mix is a direct function of the mix design air voids. Whereas, the actual maximum field density is a function of the type of coarse aggregates, natural or manufactured sands, lift thickness, roller type (static or vibratory), roller and paver speed, base condition, mix variation, etc. All of these items are taken into consideration with the growth curve.

1. High Density in the Growth Curve. If the growth curve indicates a maximum achievable field density of between 95 to 98 percent of the Theoretical Maximum Density (D), you can proceed with the Rolling Pattern. On the other hand, if the maximum achievable density is greater than 98 percent, a quick evaluation (by use of an extractor, hot bin gradations, nuclear asphalt determinator, etc.) must be made of the mix. When adjustments are made in the mix, a new growth curve shall be constructed.
2. Low Density in the Growth Curve. If the growth curve indicates the maximum achievable density is below 94 percent, a thorough evaluation of the mix, rollers, and laydown operations should be made. After a thorough evaluation of all factors (mix, rollers, etc.), asphalt or gradation changes may be in order as directed by the Engineer. Again, any changes in the mix will require a new growth curve. Note that the nuclear density test is a quality control tool and not an acceptance test. All acceptance testing is to be conducted by the use of cores, unless otherwise specified.
3. Acceptance of Test Section. The Contractor may proceed with paving the day after the test section provided the following criteria have been met:
 - a. Four random locations (2 cores per location cut longitudinally and cored by the Contractor) will be selected by the Engineer within the test strip. All the cores must show a minimum of 94% density.
 - b. All Superpave and extraction test results from mix produced for the test section must be within the tolerances required by specification.
 - c. The Contractor shall correlate his nuclear gauge to the cores taken in the test section. Additional cores may be taken at the Contractor's expense for this purpose within the test section area, when approved by the Engineer.

4. Density Acceptance under Production Paving. The responsibility for obtaining the specified density lies with the Contractor. Therefore, it is important that the nuclear density gauge operator communicate with the roller operators to maintain the specified density requirements. The Contractor shall provide a qualified HMA Density Tester who has successfully completed the Department's "HMA Nuclear Density Testing Course" to run all required density tests on the job site. Density acceptance testing, unless otherwise specified, is described as follows:
- a. The Contractor shall cut cores at random locations within 500 ton sublots as directed by the Resident Engineer.
 - b. The cores should be extracted so as not to damage them, since they are used to calculate the Contractor's pay.
 - c. The Engineer will run preliminary G_{mb} tests on the cores to give the Contractor an indication of how compaction is running for the next day's paving.
 - d. A running average of four (4) Maximum Theoretical Gravities (G_{mm}) will be used for calculating percent compaction.
 - e. Final core density tests and pay calculations will be performed by the Resident Engineer and delivered to the Contractor.
 - f. Should the contractor wish to resample the pavement as a result of pay calculations resulting in less than 100% payment, the request must be made within 48 hours of receipt of the original payment calculations.

Steven J. Long, P.E.
Acting Chief Engineer

Supersedes Policy Memorandum 2003-1 dated January 15, 2007

APPENDIX A

BITUMINOUS WORKSHEET

Airport: _____ Project No.: _____ AIP No.: _____

Mix Design #: _____ Material Code: _____ Producer: _____

Prod. #: _____

AGGREGATE

Mat'l. Code: _____

Producer #: _____

Prod. Name _____

Location: _____

Percent Passing

Sieve Size

1 inch _____

3/4 inch _____

1/2 inch _____

3/8 inch _____

No. 4 _____

No. 8 _____

No. 16 _____

No. 30 _____

No. 50 _____

No. 100 _____

No. 200 _____

Washed (y/n) _____

O.D. Gravity _____

App. Gravity _____

Absorption _____

Asphalt Gravity _____ Asphalt Source _____ Asphalt Producer No. _____

MARSHALL DATA

% Asphalt _____

M. Stability _____

Flow _____

D _____

0 _____

% Air Voids _____

Q.C. Manager Name: _____ Phone number: _____

Laboratory Location: _____ Fax Number: _____

Remarks: _____

APPENDIX B

QUALITY CONTROL TESTING (PLANT)

PARAMETER	FREQUENCY	SAMPLE SIZE	TEST METHOD	REPORT FORM
Aggregate Gradations: Hot bins for batch and continuous plants--- Individual cold-feeds or combined belt-feeds for drier drum plants.	Minimum 1 per day of production and at least 1 per 1000 tons.	CA07/11: 5000 gm CA13: 2000 gm CA16: 1500 gm Fine agg: 500 gm 1 gallon asphalt cement	ASTM C 136	AER M-9
Aggregate gradations: Stockpiles	Minimum 1 per aggregate per week per stockpile.	CA07/11: 5000 gm CA13: 2000 gm CA16: 1500 gm Fine agg: 500 gm *Note: The above test sample sizes are to be obtained from splitting down a larger sample from the stockpiles.	ASTM C 136	AER M-9
Maximum Specific Gravity	Minimum 1 per 1000 tons	1200 gm per test	ASTM D 2041	AER M-11 and AERM-14
Bulk Specific Gravity	Minimum 1 per 1000 tons	1250 gm per briquette	ASTM D 2726	AER M-11 and AERM-14
Marshall Stability and Flow	Minimum 1 per 1000 tons	1250 gm per briquette	ASTM D 1559	AER M-11 and AERM-14
% Air Voids	Minimum 1 per 1000 tons		ASTM D 3203	AER M-11 and AERM-14
Extraction	Minimum 1 per 1000 tons	1000 gm (surface) 1500 gm (base)	ASTM D 2172	AER M-11 and AERM-14
Ignition Oven Test	Minimum 1 per 1000 tons	1500 gm		AER M-14
Nuclear Asphalt Gauge	Minimum 1 per 1000 tons	1000-1100 gm	ASTM D 2145	AER M-14
Gyratory Brix	Minimum 1 per 1000 tons	4700-4800 gm 115 mm +/- 5 mm	AASHTO TP4-99	

MIX DESIGN TESTING

PARAMETER	FREQUENCY	SAMPLE SIZE	TEST METHOD	REPORT FORM
Representative samples of each aggregate and asphalt cement.	1 per aggregate and 1 asphalt cement.	280 lb. (coarse) 150 lb. (fine) 15 lb. (min. filler) 1 gallon asphalt cement	ASTM D 75	N/A
Aggregate Gradation	1 per aggregate	CA07/11: 5000 gm CA13: 2000 gm CA16: 1500 gm Fine agg: 500 gm	ASTM C 136	Bituminous Worksheet (Appendix A)
Maximum Specific Gravity	2 per specified asphalt content	1200 gm per test	ASTM D 2041	Bituminous Worksheet (Appendix A)
Bulk Specific Gravity	3 briquettes per specified asphalt content	1250 gm per briquette	ASTM D 2726	Bituminous Worksheet (Appendix A)
Marshall Stability and Flow	3 briquettes	1250 gm per briquette	ASTM D 1559	Bituminous Worksheet (Appendix A)
% Air Voids	1 per specified asphalt content (Avg. of G_{sb}/G_{mm})		ASTM D 3203	Bituminous Worksheet (Appendix A)
Gyratory Brix	Minimum 1 per 1000 tons	4700-4800 gm 115 mm +/- 5 mm	AASHTO TP4-99	

QUALITY CONTROL TESTING (PAVER)

PARAMETER	FREQUENCY	SAMPLE SIZE	TEST METHOD	REPORT FORM
Nuclear Density Test	As required by the Contractor to maintain consistent passing density	Various locations	ASTM D 2950	

APPENDIX C

AGGREGATE BITUMINOUS BASE COURSE

Percentage by Weight Passing Sieves Job Mix Formula (JMF)		
Sieve Size	Gradation B Range 1" Maximum	Ideal Target
1-1/4 in.	---	---
1 in.	100	100
3/4 in.	93 – 97	95
1/2 in.	75 – 79	77
3/8 in.	64 – 68	66
No. 4	45 – 51	48
No. 8	34 – 40	37
No. 16	27 – 33	30
No. 30	19 – 23	21
No. 100	6 – 10	8
No. 200	4 – 6	5
Bitumen %:		
Stone	4.5 – 7.0	5.5

AGGREGATE BITUMINOUS SURFACE COURSE

Percentage by Weight Passing Sieves Job Mix Formula (JMF)		
Sieve Size	Gradation B Range ^{3/4}" Maximum	Ideal Target
1 in.	100	---
3/4 in.	100	100
1/2 in.	99 - 100	100
3/8 in.	91 - 97	94
No. 4	56 - 62	59
No. 8	36 - 42	39
No. 16	27 - 32	30
No. 30	19 - 25	22
No. 100	7 - 9	8
No. 200	5 - 7	6
Bitumen %:		
Stone	5.0 - 7.0	6.0

IDOT DESIGN STANDARDS

*** MODIFY FOR 12 INCH PIPE

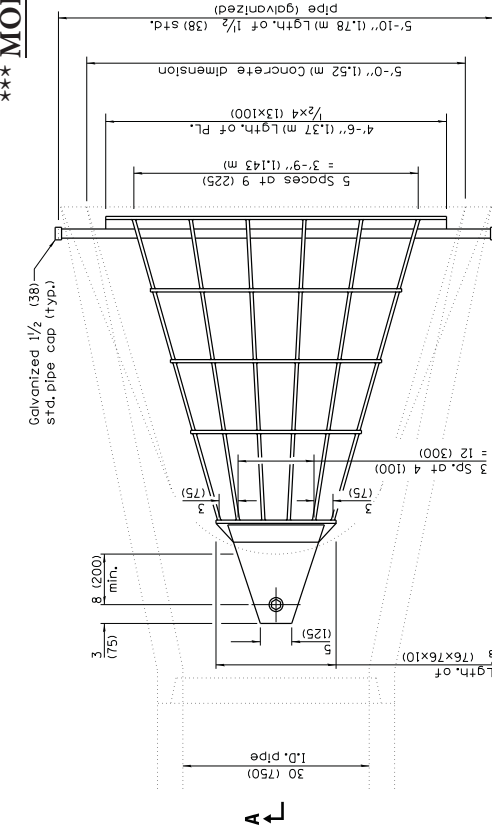

PLAN

Quantity of steel= 210 lbs.(95 kg)

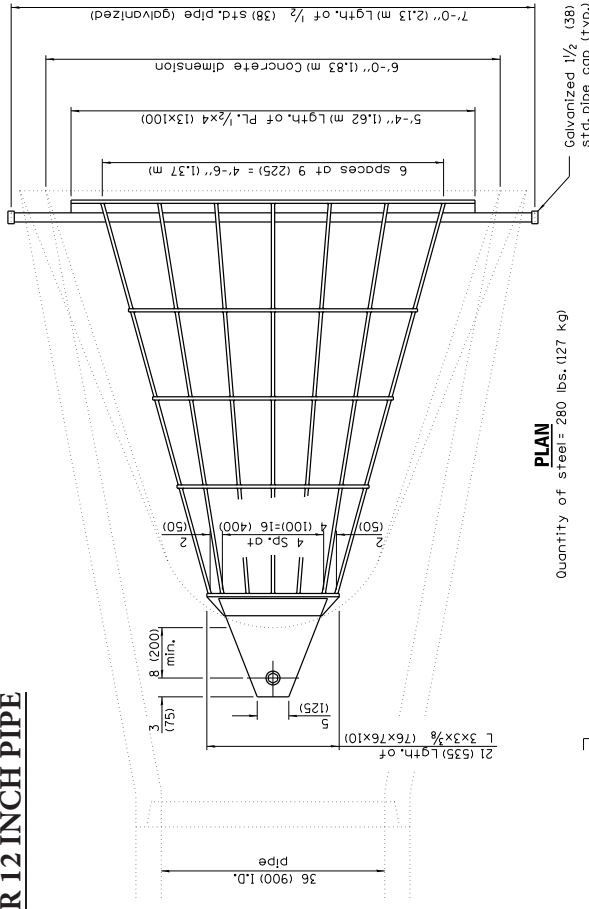

PLAN

Quantity of steel= 280 lbs.(127 kg)

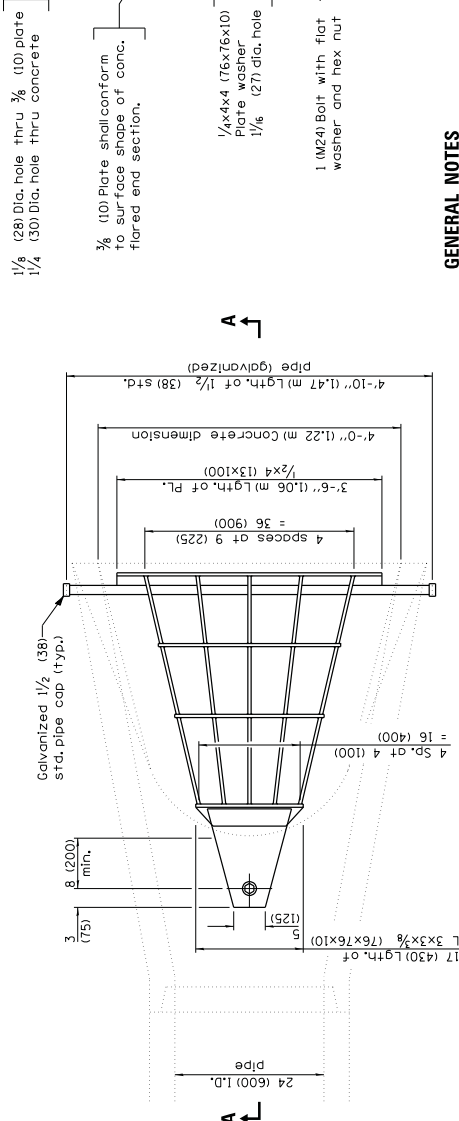

SECTION A-A

Quantity of steel= 150 lbs.(68 kg)

GENERAL NOTES

Grating details shown are intended for use with particular sizes of precast reinforced concrete flared end sections as shown on standards 542301 and 542306.

Approximate quantity of steel shown includes total quantity of grating, bolts, nuts, washers and steel pipe.

Holes in the precast concrete flared end sections shall be cored to the diameters noted. If core-out on the other end of the hole occurs, the hole shall be filled with grout to correct the diameter of the hole.

GENERAL NOTES

Grating details shown are intended for use with particular sizes of precast reinforced concrete flared end sections as shown on standards 542301 and 542306.

Approximate quantity of steel shown includes total quantity of grating, bolts, nuts, washers and steel pipe.

Holes in the precast concrete flared end sections shall be cored to the diameters noted. If core-out on the other end of the hole occurs, the hole shall be filled with grout to correct the diameter of the hole.

Illinois Department of Transportation	ISSUED 1-1-17
PASSED JANUARY 1, 2012	
ENGINEER OF POLICY AND PROCEDURES	
APPROVED JANUARY 1, 2012	
ENGINEER OF DESIGN AND ENVIRONMENT	

DATE	REVISIONS
1-1-12	Corrected diameter dimension for 48 inch pipe.
1-1-11	Corrected weld symbols.

GRATING FOR CONCRETE FLARED END SECTION (FOR 24" (600 mm) THRU 54" (1350 mm) PIPE) ***
 STANDARD 542311-03
 (Sheet 1 of 2)

All dimensions are in inches (millimeters) unless otherwise shown.

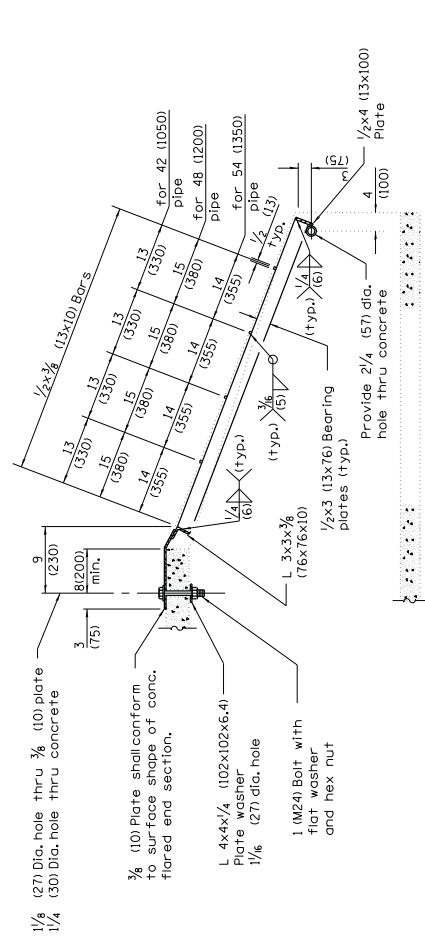
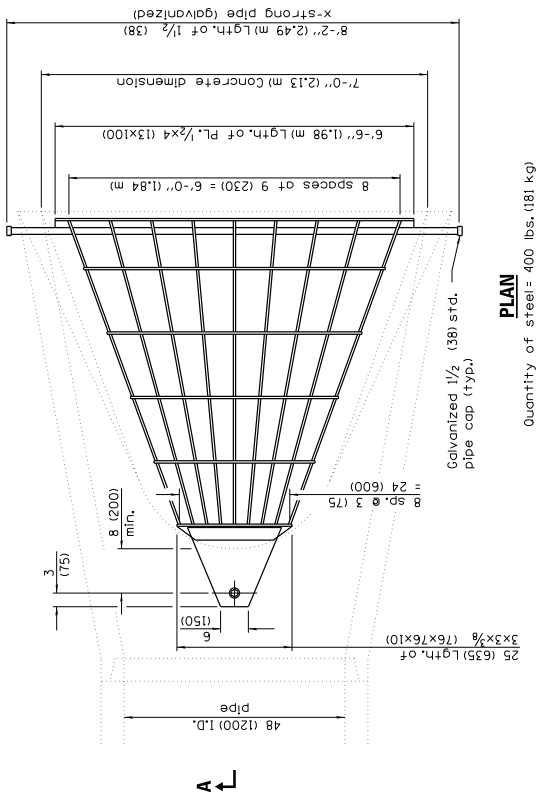
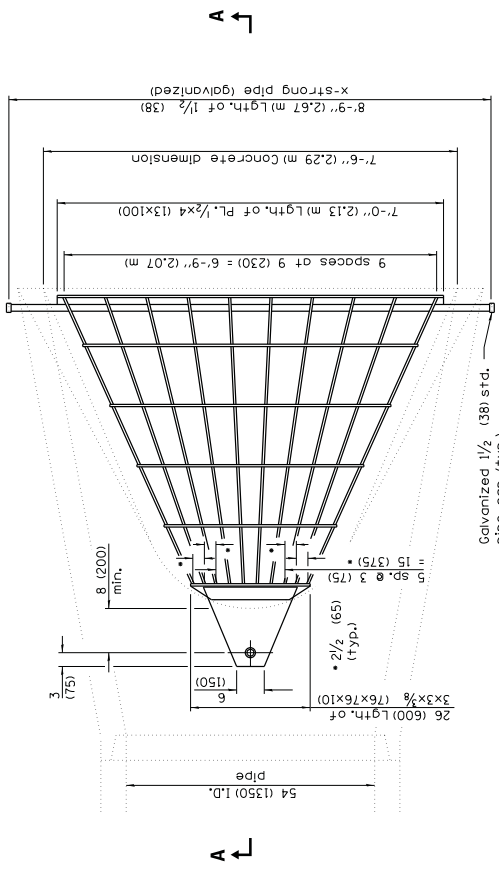
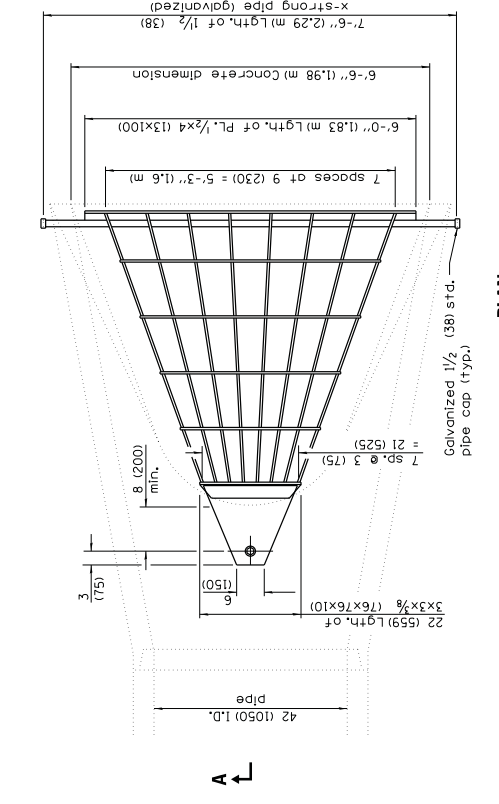

Illinois Department of Transportation
 PASSED JANUARY 1, 2012
 ENGINEER OF POLICY AND PROCEDURES
 APPROVED JANUARY 1, 2012
 ENGINEER OF DESIGN AND ENVIRONMENT

*** **MODIFY FOR 12 INCH PIPE** ***
 (Sheet 2 of 2)

**GRATING FOR CONCRETE
 FLARED END SECTION
 (FOR 24" (600 mm) THRU
 54" (1350 mm) PIPE) *****

STANDARD 542311-03

PIPE DIA.	APPROX. QTY. lbs. (kg.)	WALL	A	B	C	D	E	C	R	APPROX. SLOPE
12 (300)	530 (240)	2 (51)	4 (102)	24 (610)	4'-0 7/8" (1,241 mm)	6'-0 7/8" (1,851 mm)	24 (610)	2 (51)	9 (229)	1:2.4
15 (375)	740 (335)	2 1/4 (57)	6 (152)	27 (686)	3'-10" (1,168 mm)	6'-1" (1,854 mm)	30 (762)	2 1/4 (57)	11 (280)	1:2.4
18 (450)	990 (450)	2 1/2 (64)	9 (229)	27 (686)	3'-10" (1,168 mm)	6'-1" (1,854 mm)	36 (914)	2 1/2 (64)	12 (305)	1:2.4
21 (525)	1280 (580)	2 3/4 (70)	9 (229)	35 (889)	38 (965)	6'-1" (1,854 mm)	3'-6" (1,067 mm)	2 3/4 (70)	13 (330)	1:2.4
24 (600)	1520 (690)	3 (76)	9 1/2 (241)	3'-7 1/2" (1,105 mm)	30 (762)	6'-1 1/2" (1,817 mm)	4'-0" (1,219 mm)	3 (76)	14 (356)	1:2.5
27 (675)	1930 (875)	3 1/4 (83)	10 1/2 (267)	4'-0" (1,219 mm)	25 1/2 (646)	6'-3 1/2" (1,927 mm)	4'-6" (1,372 mm)	3 1/4 (83)	14 1/2 (368)	1:2.4
30 (750)	2190 (995)	3 1/2 (89)	12 (305)	4'-6" (1,375 mm)	19 1/4 (502)	6'-1 3/4" (1,874 mm)	5'-0" (1,524 mm)	3 1/2 (89)	15 (381)	1:2.5
33 (825)	3200 (1450)	3 3/4 (95)	13 1/2 (343)	4'-10 1/2" (1,486 mm)	39 1/4 (997)	8'-1 3/4" (2,483 mm)	5'-6" (1,676 mm)	3 3/4 (95)	17 1/2 (445)	1:2.5
36 (900)	4100 (1860)	4 (102)	15 (381)	5'-3" (1,6 m)	34 3/4 (883)	8'-1 3/4" (2,483 mm)	6'-0" (1,829 mm)	4 (102)	20 (508)	1:2.5
42 (1050)	5380 (2440)	4 1/2 (114)	21 (533)	5'-3" (1,6 m)	35 (889)	8'-2" (2,489 mm)	6'-6" (1,981 mm)	4 1/2 (114)	22 (559)	1:2.5
48 (1200)	6550 (2970)	5 (127)	24 (610)	6'-0" (1,829 mm)	36 (914)	8'-2" (2,489 mm)	7'-0" (2,134 mm)	5 (127)	22 (559)	1:2.5
54 (1350)	8240 (3740)	5 1/2 (140)	27 (686)	5'-5" (1,651 mm)	35 (889)	8'-4" (2,54 mm)	7'-6" (2,286 mm)	5 1/2 (140)	24 (610)	1:2.0
60 (1500)	8730 (3960)	6 (152)	35 (889)	5'-0" (1,524 mm)	39 (991)	8'-3" (2,515 mm)	8'-0" (2,438 mm)	6 (152)	24 (610)	1:1.9
66 (1650)	10710 (4860)	6 1/2 (165)	30 (762)	6'-0" (1,829 mm)	27 (686)	8'-3" (2,515 mm)	8'-6" (2,591 mm)	6 1/2 (165)	24 (610)	1:1.7
72 (1800)	12520 (5680)	7 (178)	36 (914)	6'-6" (1,981 mm)	21 (533)	8'-3" (2,515 mm)	9'-0" (2,743 mm)	7 (178)	24 (610)	1:1.8
78 (1950)	14770 (6700)	7 1/2 (191)	36 (914)	7'-6" (2,286 mm)	21 (533)	9'-3" (2,819 mm)	9'-6" (2,896 mm)	7 1/2 (191)	24 (610)	1:1.8
84 (2100)	18160 (8240)	8 (203)	36 (914)	7'-6" (2,286 mm)	21 (533)	9'-3 1/2" (2,832 mm)	10'-0" (3,048 mm)	8 (203)	24 (610)	1:1.6

* Radius as furnished by manufacturer

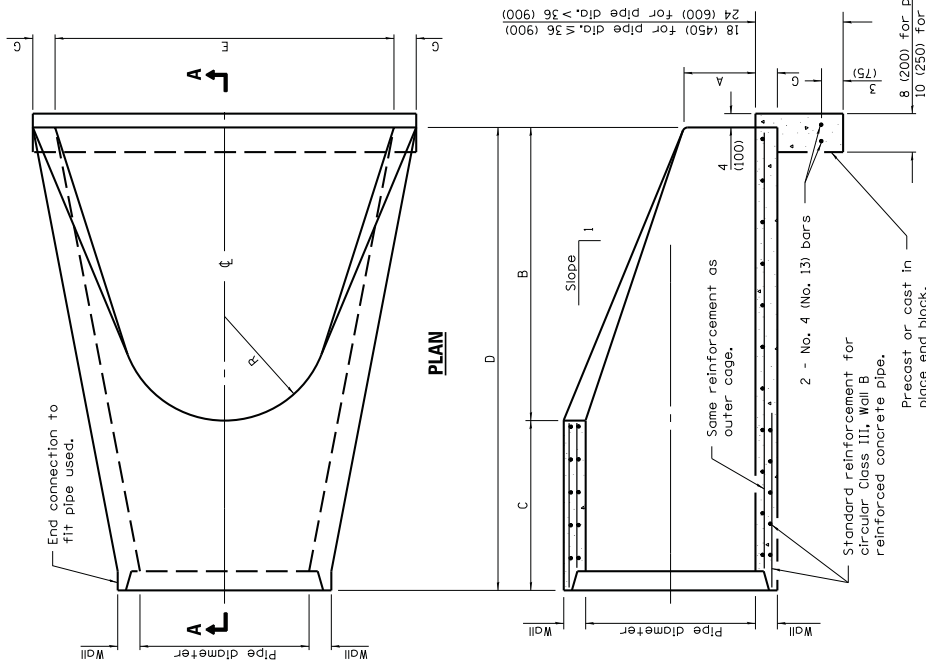

24 (600) for pipe dia. ≤ 36 (900)
 18 (450) for pipe dia. ≤ 36 (900)
 10 (250) for pipe dia. > 36 (900)

SECTION A-A

END VIEW

GENERAL NOTES

All slope ratios are expressed as units of vertical displacement to units of horizontal displacement (V:H).
 All dimensions are in inches (millimeters) unless otherwise shown.

Illinois Department of Transportation
 APPROVED: January 1, 2011
Joseph E. Anderson
 ENGINEER OF BRIDGES AND STRUCTURES
 APPROVED: January 1, 2011
Joseph E. Anderson
 ENGINEER OF DESIGN AND ENVIRONMENT

DATE	REVISIONS
1-1-11	Clarified ref. to pipe dia. on Section A-A. Changed "inner" to "outer" cage ref.
1-1-09	Switched units to English (metric).

PRECAST REINFORCED CONCRETE FLARED END SECTION

STANDARD 542301-03

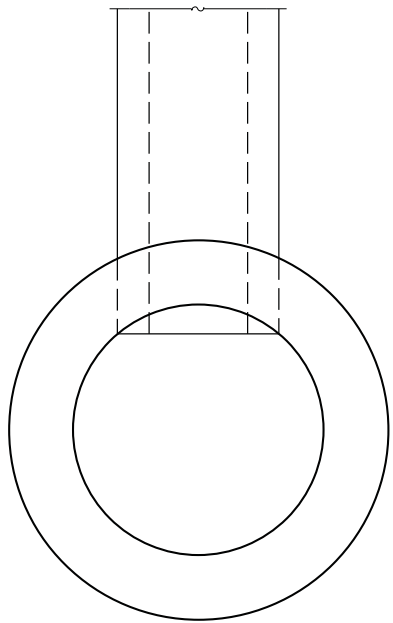

PLAN

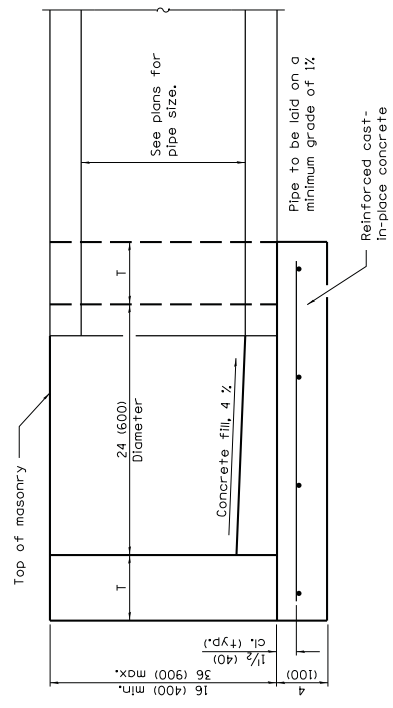

ELEVATION

ALTERNATE MATERIALS FOR WALLS	T
BRICK MASONRY	8 (200)
CAST-IN-PLACE CONCRETE	6 (150)
CONCRETE MASONRY UNIT	5 (125)
PRECAST REINFORCED CONCRETE SECTION	3 (75)

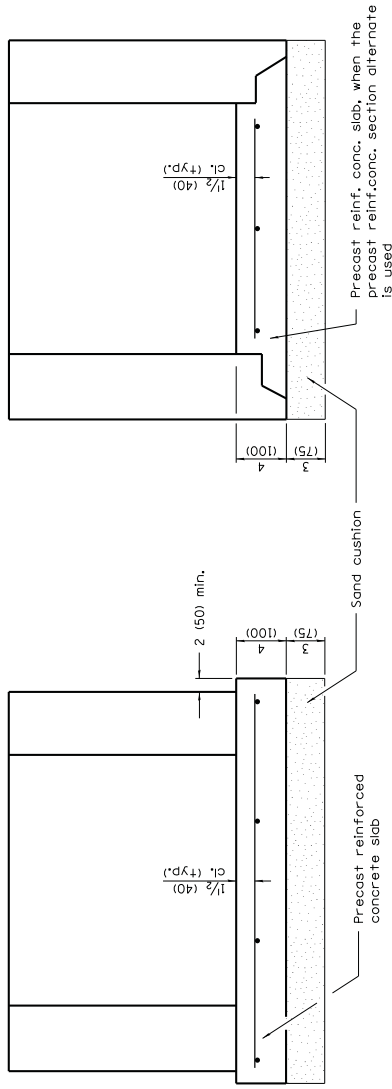

ALTERNATE METHODS

GENERAL NOTES

Bottom slabs shall be reinforced with a minimum of 0.24 sq. in./ft. (510 sq. mm/m) in both directions with a maximum spacing of 10 (250).

Bottom slabs may be connected to the riser as determined by the fabricator; however, only a single row of reinforcement around the perimeter may be utilized.

All dimensions are in inches (millimeters) unless otherwise shown.

DATE	REVISIONS
1-1-11	Detailed reinf. in slabs.
	Added max. limit to height.
	Added general notes.
1-1-09	Switched units to English (metric).

INLET - TYPE A

STANDARD 602301-03

Illinois Department of Transportation
 PASSED JANUARY 1, 2011
 ENGINEER OF POLICY AND PROCEDURES
 APPROVED JANUARY 1, 2011
 ENGINEER OF DESIGN AND ENVIRONMENT

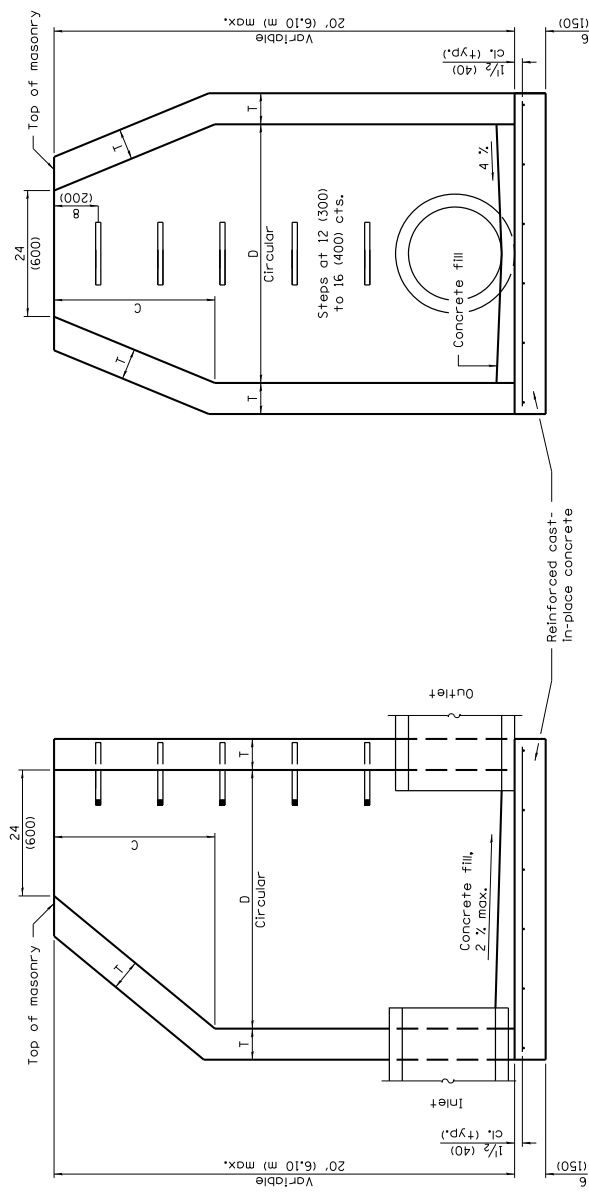

ELEVATION - ECCENTRIC

ELEVATION - CONCENTRIC

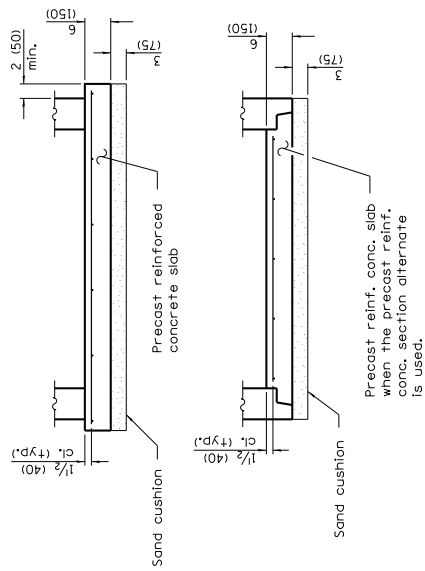

ALTERNATE BOTTOM SLAB

ALTERNATE MATERIALS FOR WALLS	D	C*	T (min.)
Concrete Masonry Unit	4'-0" (1.2 m) 5'-0" (1.5 m)	30 (750) 3'-9" (1.15 m)	5 (125) 5 (125)
Brick Masonry	4'-0" (1.2 m) 5'-0" (1.5 m)	30 (750) 3'-9" (1.15 m)	8 (200) 8 (200)
Precast Reinforced Concrete Section	4'-0" (1.2 m) 5'-0" (1.5 m)	30 (750) 3'-9" (1.15 m)	4 (100) 5 (125)
Cast-in-place Concrete	4'-0" (1.2 m) 5'-0" (1.5 m)	30 (750) 3'-9" (1.15 m)	6 (150) 6 (150)

* For precast reinforced concrete sections, dimension "C" may vary from the dimension given to plus 6 (150).

GENERAL NOTES

Bottom slabs shall be reinforced with a minimum of 0.31 sq. in./ft. (660 sq. mm/m) in both directions with a maximum spacing of 12 (300).

Bottom slabs may be connected to the riser as determined by the fabricator; however, only a single row of reinforcement around the perimeter may be utilized.

See Standard 602701 for details of steps.

See Standard 602601 for optional Precast Reinforced Concrete Flat Slab Top.

All dimensions are in inches (millimeters) unless otherwise shown.

DATE	REVISIONS
1-1-11	Detailed reinf. in slabs.
	Added max. limit to height.
	Revised general notes.
1-1-09	Switched units to English metric.

MANHOLE TYPE A

STANDARD 602401-03

Illinois Department of Transportation
 PASSED JANUARY 1, 2011
 ENGINEER OF POLICY AND PROCEDURES
 APPROVED JANUARY 1, 2011
 ENGINEER OF DESIGN AND ENVIRONMENT

ISSUED 1-1-97

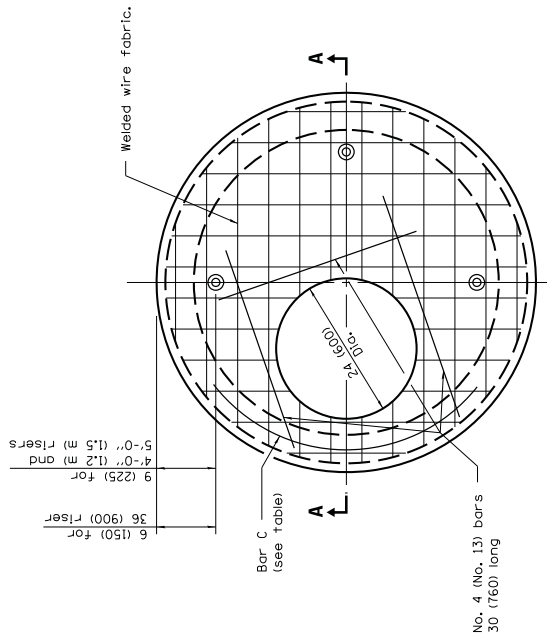

PLAN
(WELDED WIRE FABRIC)

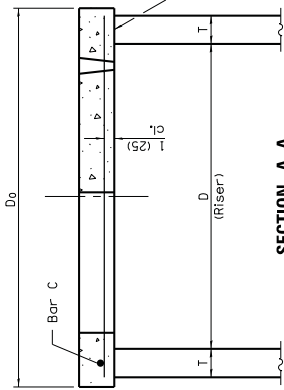

SECTION A-A

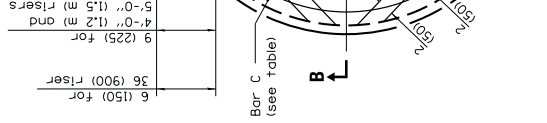

PLAN
(REINFORCEMENT BARS)

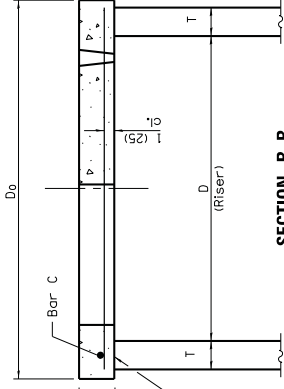

SECTION B-B

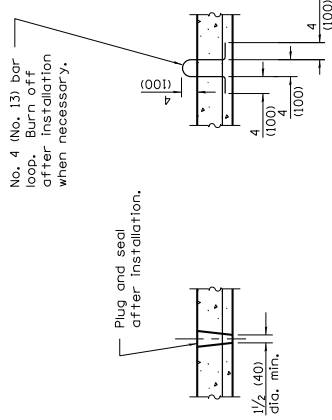

LIFTING HOLE OR LIFTING LOOP
TYPICAL

(3 required per slab)

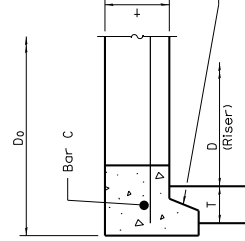

ALTERNATE JOINT CONFIGURATIONS

TABLE

D	T	D0 (min.)	Reinforcement "As" W.W.F. size each direction	No. 4 (No. 13) Bar C Length	No. 4 (No. 13) Bar C Radius
36 (900)	21	21	6 0.20 sq. in./ft. (425 sq. mm/m)	No. 4 4'-0" (1.2 m)	19 (480)
4'-0" (1.2 m)	21	21	6 0.35 sq. in./ft. (740 sq. mm/m)	No. 5 4'-6" (1.35 m)	26 (660)
5'-0" (1.5 m)	21	21	8 0.35 sq. in./ft. (740 sq. mm/m)	No. 5 5'-0" (1.5 m)	32 (810)

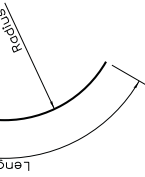

GENERAL NOTES

The flat slab top may be used in lieu of the tapered tops shown on Standards 602001, 602011, 602016, 602306, 602401, or 602501 at the option of the Contractor or when field conditions prohibit the use of tapered tops.

All dimensions are in millimeters (inches) unless otherwise shown.

Illinois Department of Transportation
ISSUED 1-1-97

PASSED JANUARY 1, 2009
ENGINEER OF POLICY AND PROCEDURES
APPROVED JANUARY 1, 2009
ENGINEER OF DESIGN AND ENVIRONMENT

DATE	REVISIONS
1-1-09	Switched units to English (metric).
1-1-07	Soft converted metric reinforcement bars.

**PRECAST REINFORCED
CONCRETE FLAT SLAB TOP**

STANDARD 602601-02

CAST IRON STEPS

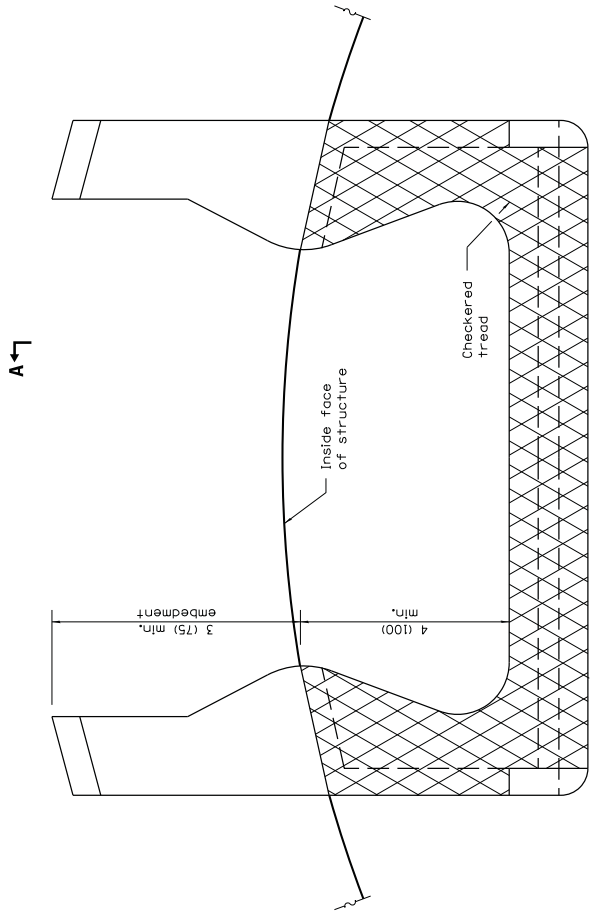

PLAN VIEW

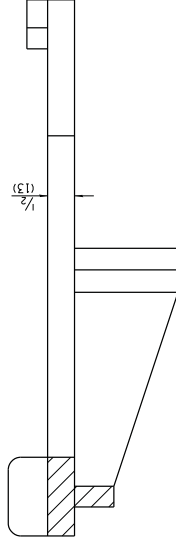

SECTION A-A

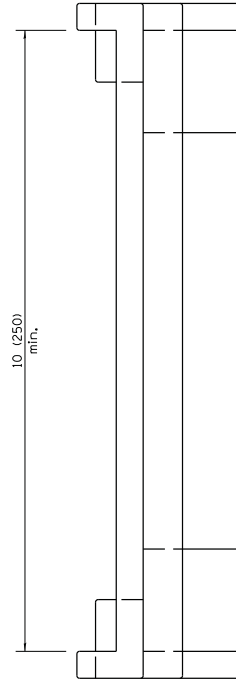

ELEVATION VIEW

All dimensions are in inches (millimeters) unless otherwise shown.

DATE	REVISIONS
1-1-09	Switched units to English (metric).
4-1-06	Revised title, drawings, and added plastic steps on sheet 2.

MANHOLE STEPS

(Sheet 1 of 2)

STANDARD 602701-02

Illinois Department of Transportation PASSED ENGINEER OF POLICY AND PROCEDURES APPROVED ENGINEER OF DESIGN AND ENVIRONMENT	JACQUELYN L. 2009 <i>Jacquelyn L.</i>	ISSUED 1-1-97
	JACQUELYN L. 2009 JACQUELYN L. 2009 JACQUELYN L. 2009	

PLASTIC STEPS

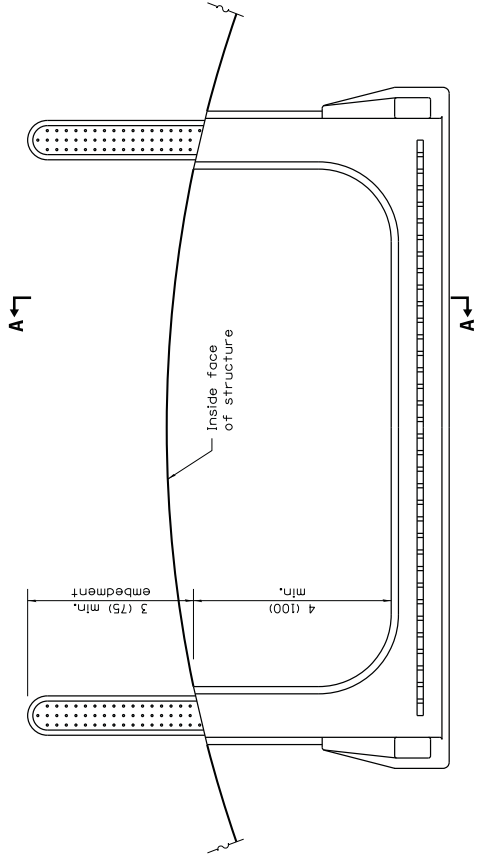

PLAN VIEW

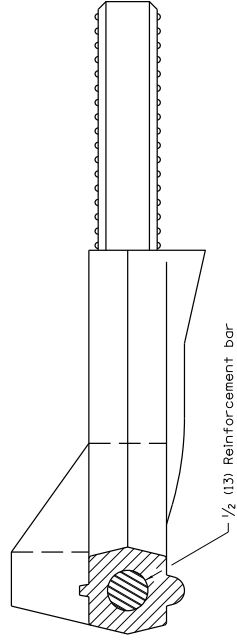

SECTION A-A

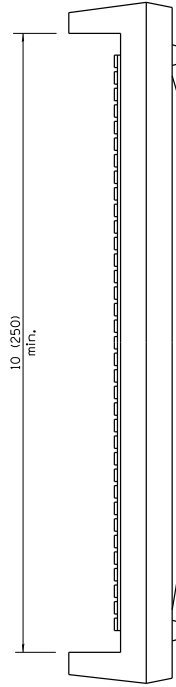

ELEVATION VIEW

Illinois Department of Transportation
PASSED _____ 2009
ENGINEER OF POLICY AND PROCEDURES
APPROVED _____ 2009
ENGINEER OF DESIGN AND ENVIRONMENT

MANHOLE STEPS

(Sheet 2 of 2)

STANDARD 602701-02

6 Gussets shown
8 permitted

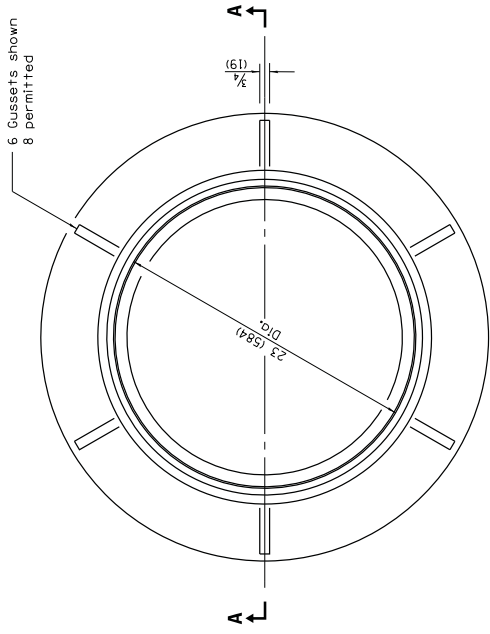

CAST FRAME

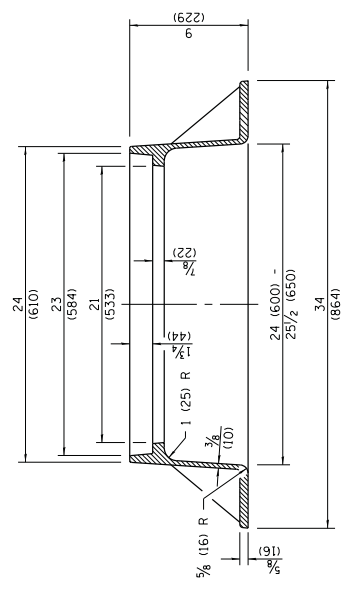

SECTION A-A
Gray Iron

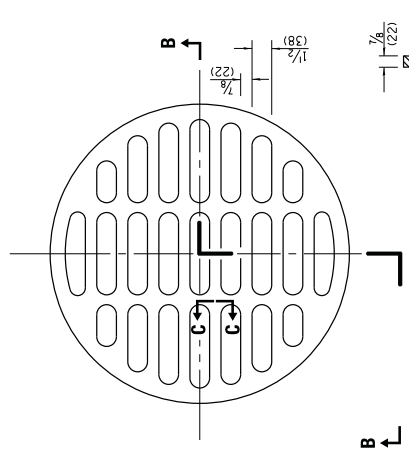

SECTION C-C

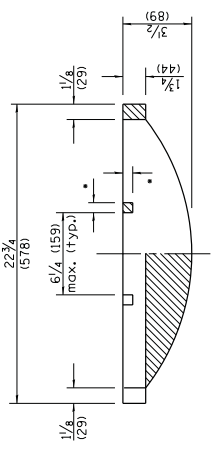
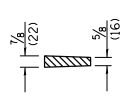

SECTION B-B

CAST OPEN LID

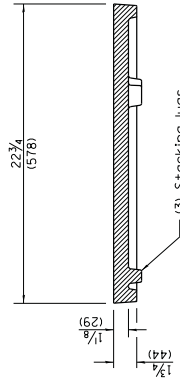
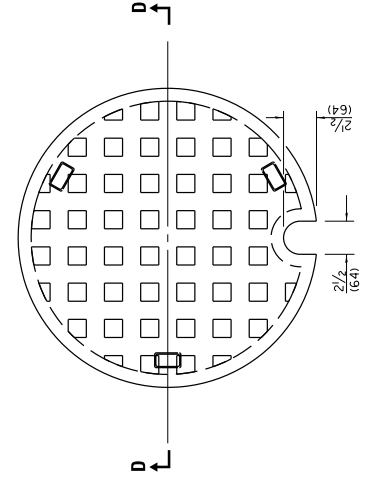

SECTION D-D

CAST CLOSED LID
Gray Iron Lid

(3) Stacking lugs
at 120° (optional)

All dimensions are in inches (millimeters)
unless otherwise shown.

REVISIONS	
DATE	Switched units to English (metric).
1-1-09	Removed weights.
1-1-04	

Illinois Department of Transportation PASSED JANUARY 1, 2009 ENGINEER OF POLICY AND PROCEDURES APPROVED <i>[Signature]</i> JANUARY 1, 2009 ENGINEER OF DESIGN AND ENVIRONMENT	ISSUED 1-1-97
---	---------------

FRAME AND LIDS
TYPE 1
STANDARD 604001-03

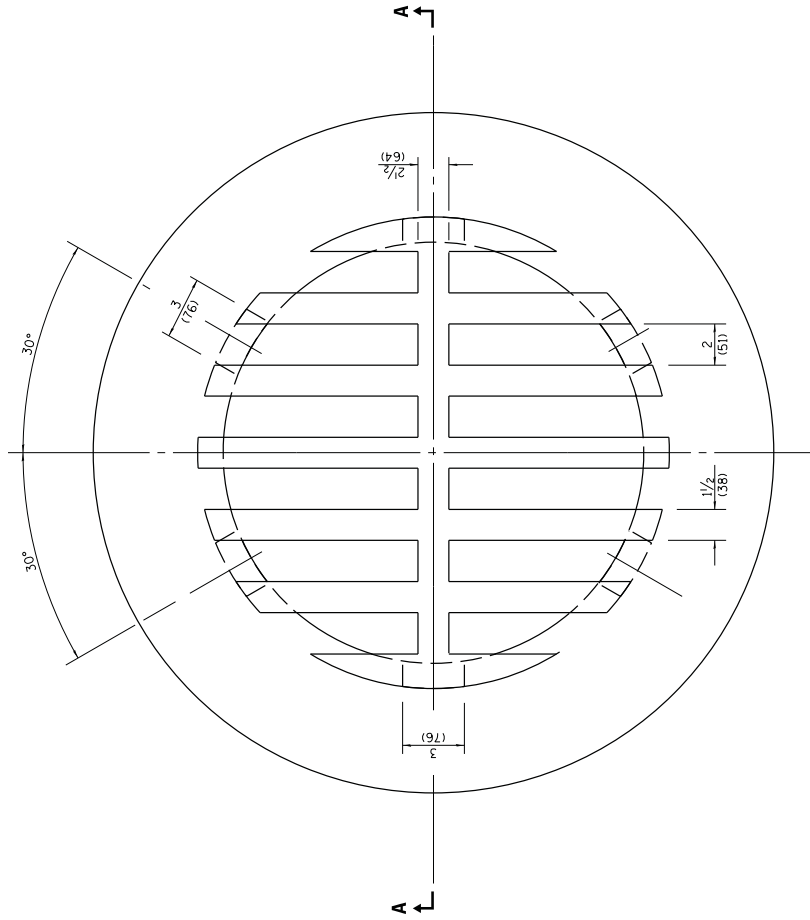

CAST GRATE

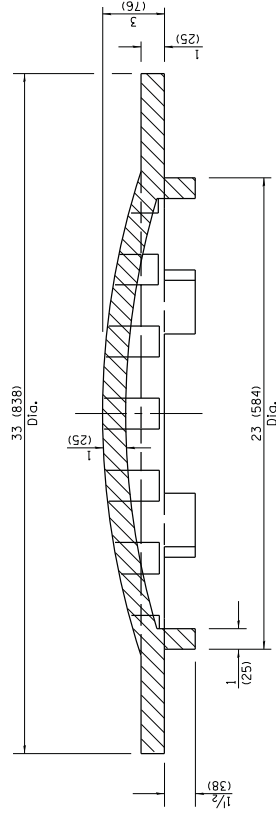

SECTION A-A

All dimensions are in inches (millimeters) unless otherwise shown.

DATE	REVISIONS
1-1-09	Switched units to English (metric).
1-1-04	Removed weights.

GRATE TYPE 8

STANDARD 604036-02

Illinois Department of Transportation PASSED January 1, 2009 ENGINEER OF POLICY AND PROCEDURES APPROVED January 1, 2009 ENGINEER OF DESIGN AND ENVIRONMENT	ISSUED 1-1-97
	Michael Beard [Signature]

F SHAPE DESIGN

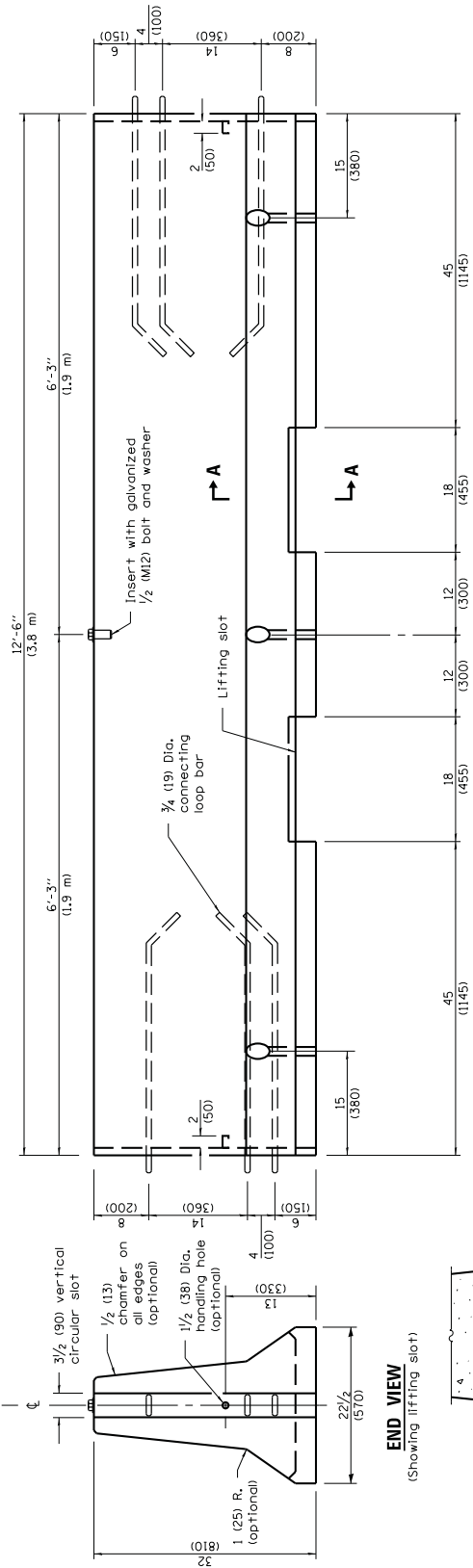

ELEVATION

(Showing connecting loop bars and vertical panel bolt/insert)

END VIEW

(Showing lifting slot)

TOP VIEW

Type C marker (typ.)

SECTION A-A

LIFTING SLOT

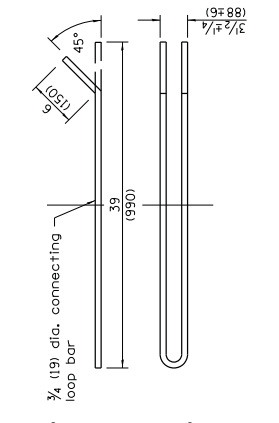

PLAN

2 1/2 (63) measured from face of barrier to end of loop bar

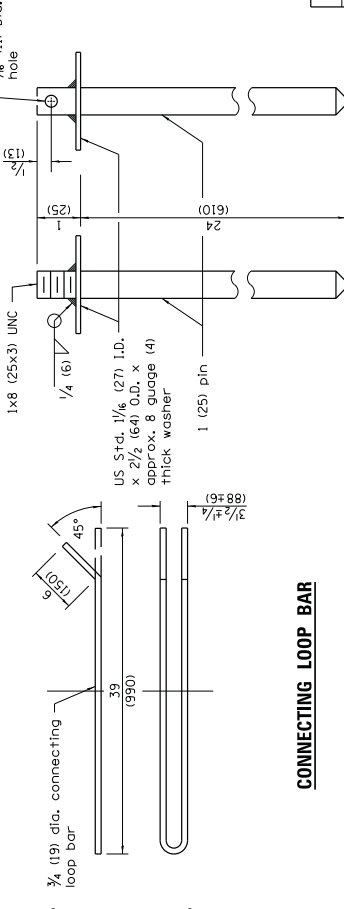

CONNECTING LOOP BAR

CONNECTING AND ANCHOR PINS

(End may be beveled 1/4 (6) max.)

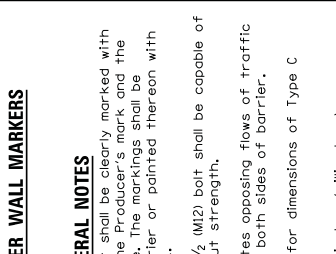

GENERAL NOTES

Each F shape barrier shall be clearly marked with "ILLINOIS F SHAPE", the Producer's mark and the date of manufacture. The markings shall be indented on the barrier or painted thereon with waterproof paint/ink.

The insert for the 1/2 (M12) bolt shall be capable of 3,000 lb (13 kN) pull-out strength.

When barrier separates opposing flows of traffic markers shall be on both sides of barrier.

See Standard 635011 for dimensions of Type C marker.

All dimensions are in inches (millimeters) unless otherwise shown.

BARRIER WALL MARKERS

DATE	REVISIONS
1-1-12	Omitted 'ALTERNATE' From connecting and anchoring pins detail.
1-1-10	Revised General Notes.

TEMPORARY CONCRETE BARRIER

(Sheet 1 of 2)

STANDARD 704001-07

Illinois Department of Transportation

PASSED January 1, 2012

ENGINEER OF POLICY AND PROCEDURES

APPROVED January 1, 2012

ISSUED 10-1-02

ENGINEER OF DESIGN AND ENVIRONMENT

