

DETAILS OF PLANTING AND BRACING TREES

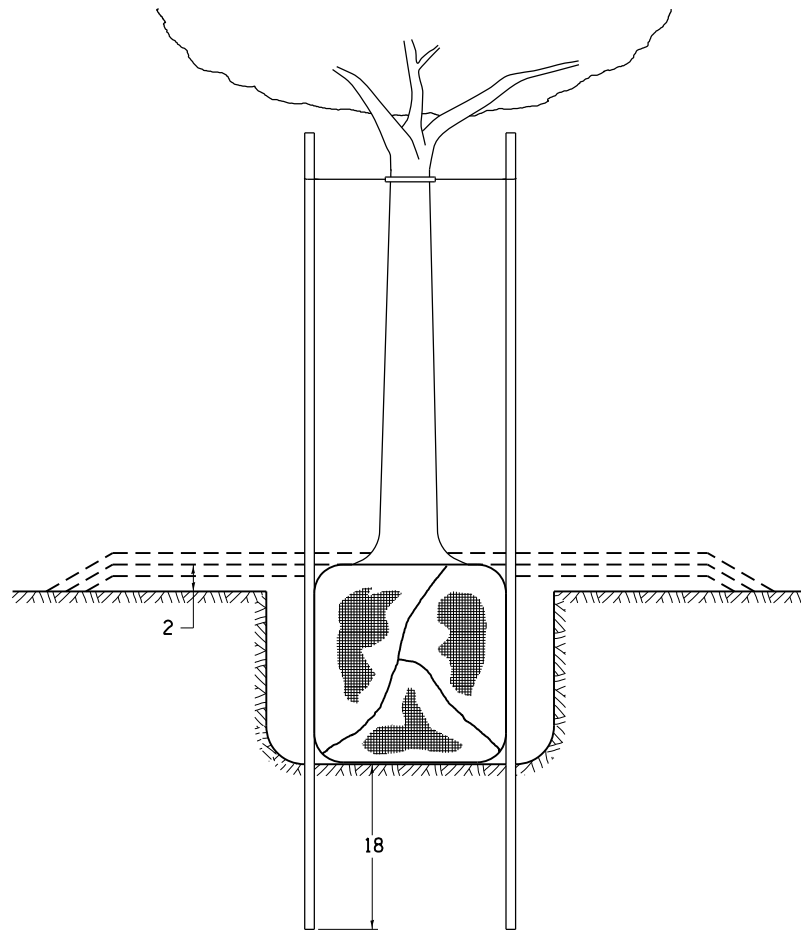

TREES SMALLER THAN 4 1/2 IN DIAMETER

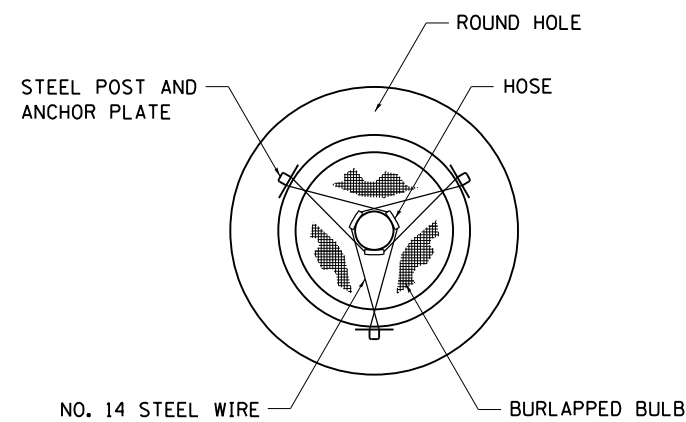

SMALL	A	B	C	D	E	F
TREE SIZE	DIAMETER OF BALL OR ROOT SYS.	DEPTH OF HOLE EXCAVATION	WIDTH OF HOLE EXCAVATION	THICKNESS OF MULCH COVER	DEPTH OF BALL OR ROOT SYS.	VOLUME OF MULCH COVER CU. YDS.
5'-6'	16	10	30	4	12	0.54
5'-6' BB	16	10	30	4	12	0.54
6'-7' BB	18	12	30	4	14	0.54
7'-8' BB	20	11	30	4	13	0.54
8'-10' BB	24	14	36	4	16	0.61
10'-12' BB	26	15	36	4	17	0.61

LARGE	A	B	C	D	E	F
TREE SIZE	DIAMETER OF BALL OR ROOT SYS.	DEPTH OF HOLE EXCAVATION	WIDTH OF HOLE EXCAVATION	THICKNESS OF MULCH COVER	DEPTH OF BALL OR ROOT SYS.	VOLUME OF MULCH COVER CU. YDS.
0-2	20	11	36	4	13	0.61
2-2 1/2 BB	24	14	48	4	16	0.78
2 1/2-3 BB	28	17	48	4	19	0.78
3-3 1/2 BB	32	17	60	4	19	0.96
3 1/2-4 BB	36	20	60	4	22	0.96
4-4 1/2 BB	40	22	72	4	24	1.16
4 1/2-5 BB	44	24	72	4	26	1.16
5-5 1/2 BB	48	27	84	4	29	1.38

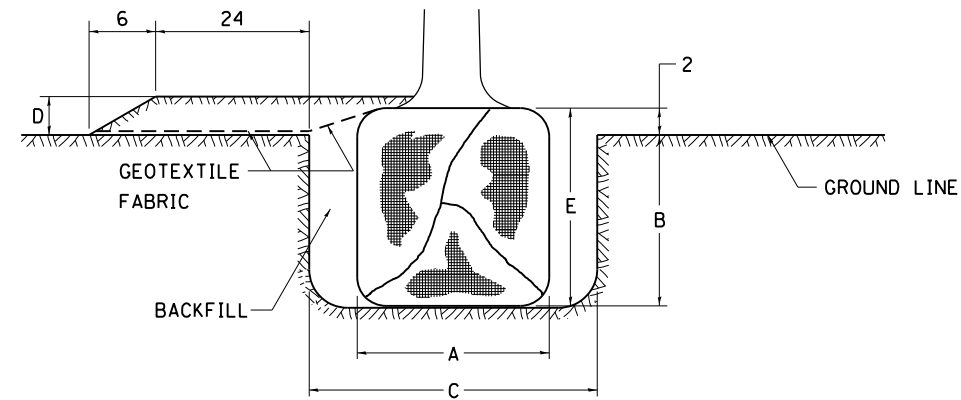

TREES OVER 4 1/2 IN DIAMETER

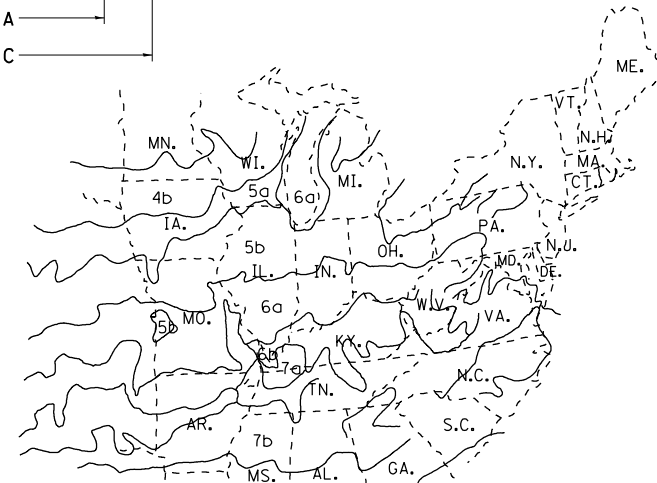

PLANT HARDINESS ZONE MAP

U.S. DEPARTMENT OF AGRICULTURE
AGRICULTURAL RESEARCH SERVICE
PUBLICATION NO. 814

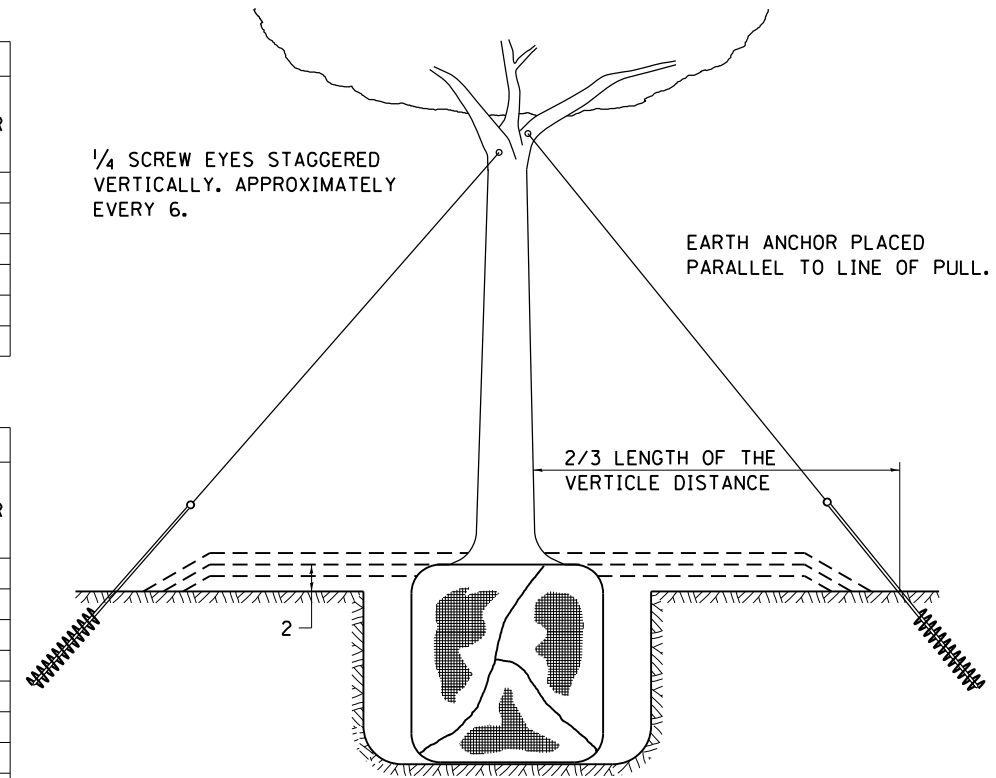

1/4 SCREW EYES STAGGERED VERTICALLY. APPROXIMATELY EVERY 6.

EARTH ANCHOR PLACED PARALLEL TO LINE OF PULL.

2/3 LENGTH OF THE VERTICAL DISTANCE

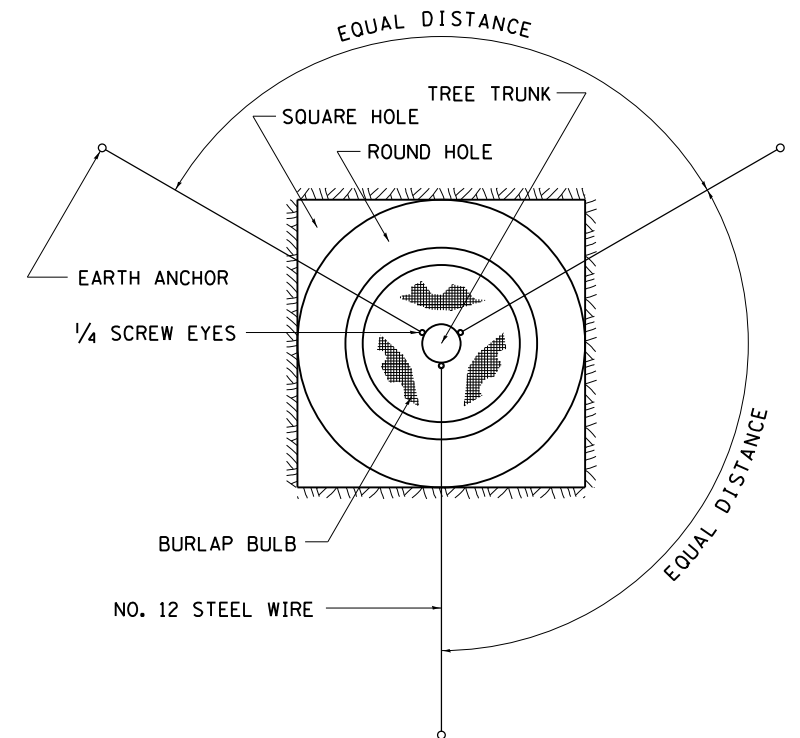

ALL DIMENSIONS ARE IN INCHES UNLESS OTHERWISE NOTED.

FILE NAME =	USER NAME = renkesw	DESIGNED -	REVISED - 10-18-11
ca:\pw\work\p\idot\renkesw\d0261271\0207411-sht-details.dgn		DRAWN -	REVISED -
		CHECKED -	REVISED -
		DATE -	REVISED -

STATE OF ILLINOIS
DEPARTMENT OF TRANSPORTATION

REGION 2 / DISTRICT 2 STANDARD

SCALE: SHEET NO. OF SHEETS STA. TO STA.

F.A.P. RTE.	SECTION	COUNTY	TOTAL SHEETS	SHEET NO.
599	(83MFT & 103MFT)W	ROCK ISLAND	340	228
CONTRACT NO.			64H11	
FED. ROAD DIST. NO.		ILLINOIS FED. AID PROJECT		