

SECTION A-A

Limits of Removal & Disposal of Unsuitable Material for Structures

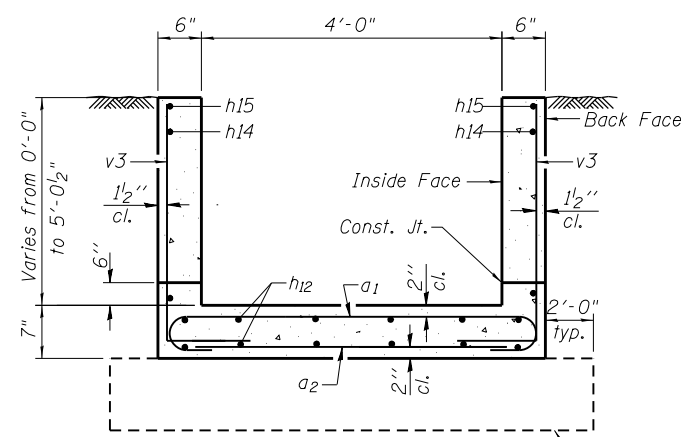

SECTION B-B

Limits of Removal & Disposal of Unsuitable Material for Structures

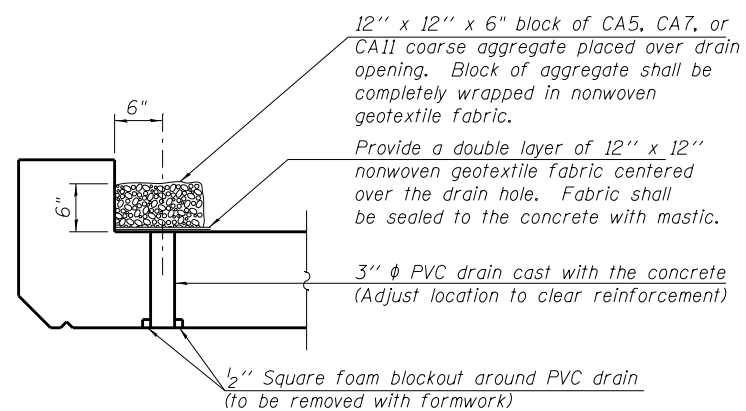

DRAIN DETAIL

(All costs associated with furnishing and constructing the above drain details will not be measured for payment but shall be included in the contract unit price for the end section.)

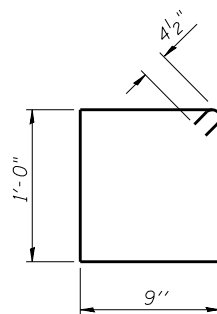

BAR s₂

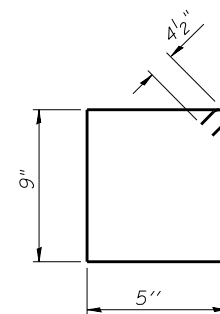

BAR s₁

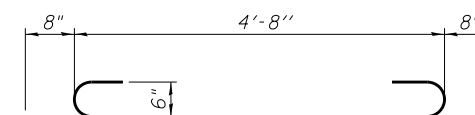

BAR a₁

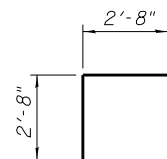

BAR d₁

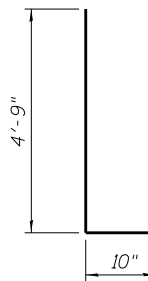

BAR v

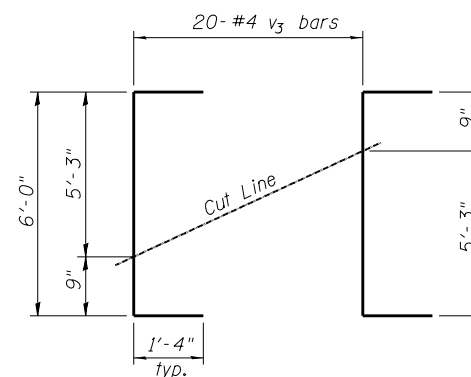

BAR v₃

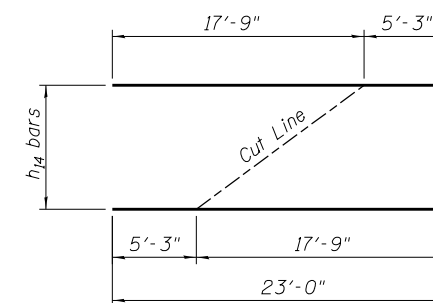

BAR h₁₄

BILL OF MATERIAL
(For Information Only)

Bar	No.	Size	Length	Shape
a ₁	118	#6	6'-0"	
a ₂	50	#4	4'-8"	
a ₃	12	#6	4'-8"	
b	3	#4	4'-8"	
d ₁	5	#4	5'-4"	
h ₉	8	#5	2'-8"	
h ₁₀	10	#6	2'-3"	
h ₁₁	7	#6	20'-9"	
h ₁₂	20	#4	19'-1"	
h ₁₃	8	#5	20'-9"	
h ₁₄	5	#5	23'-0"	
h ₁₅	2	#5	16'-3"	
h ₁₆	4	#5	2'-1"	
s ₁	10	#4	3'-1"	
s ₂	5	#4	4'-3"	
v	64	#4	5'-7"	
v ₃	20	#4	8'-8"	
DESCRIPTION		UNIT	QTY.	
Concrete Box Culverts		Cu. Yd.	11.1	
Reinforcement Bars		Pound	2,580	

FILE NAME = W:\Projects\2010\100120 PTB 157\25\cadd\Structural\Drawn\03 IL 92 Culverts\Station960+23.08\Final_Submittal_13.03.2010\960+23.08\64H11-006-Culv_Extension_Detail.dwg