

FILE NAME = W:\Projects\2010\100120\_PTB\_157\25\cadd\Structural\Drawings\92\_Culverts\Station832+82.45\Final\_Submittal\130320\832+82.45-64H1-003-ExtensionDetail.dgn

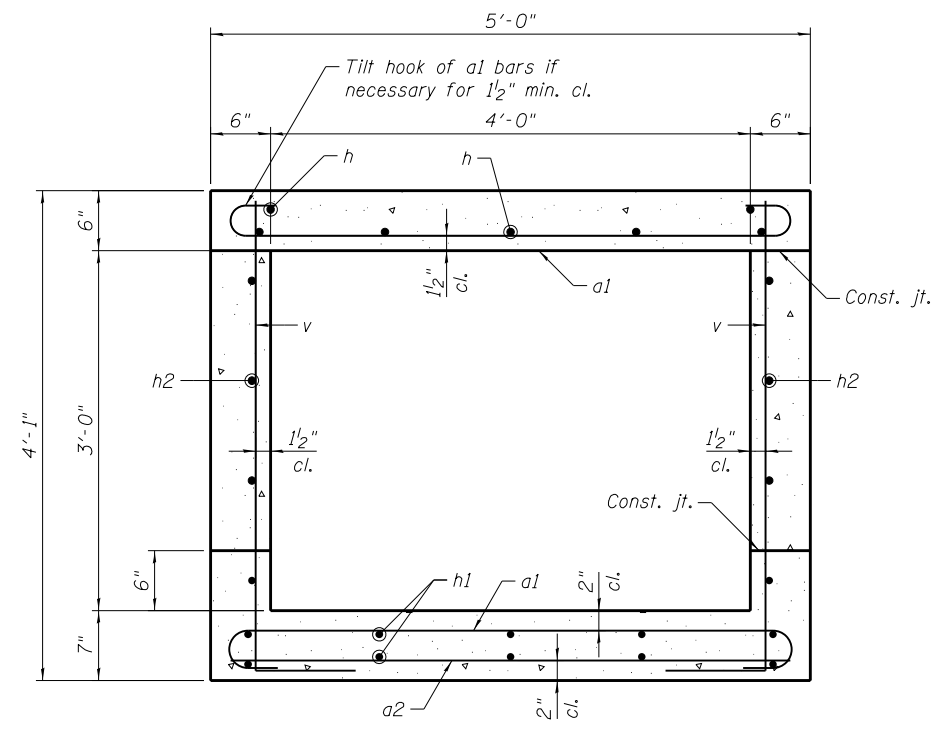

**SECTION A-A**

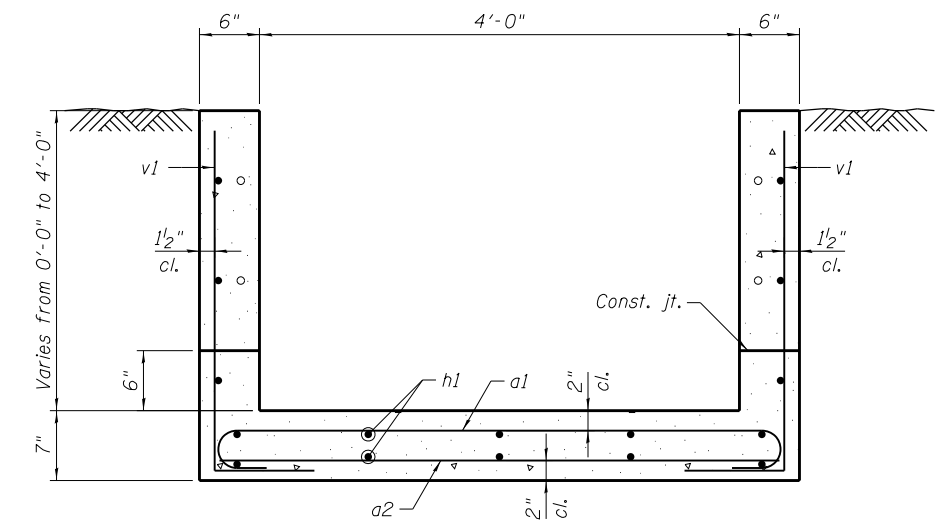

**SECTION B-B**

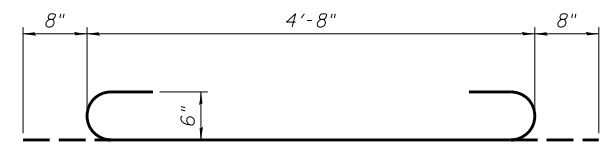

**BAR a1**

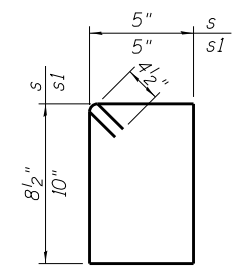

**BARS s & s1**

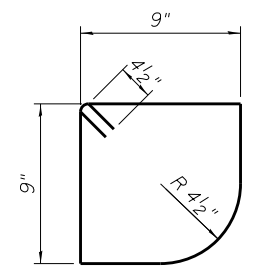

**BAR s2**

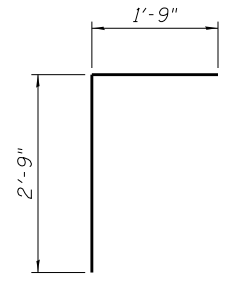

**BAR d**

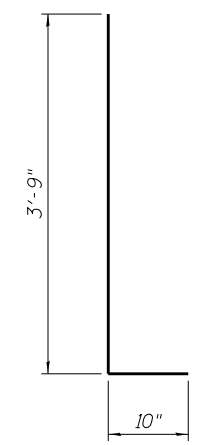

**BAR v**

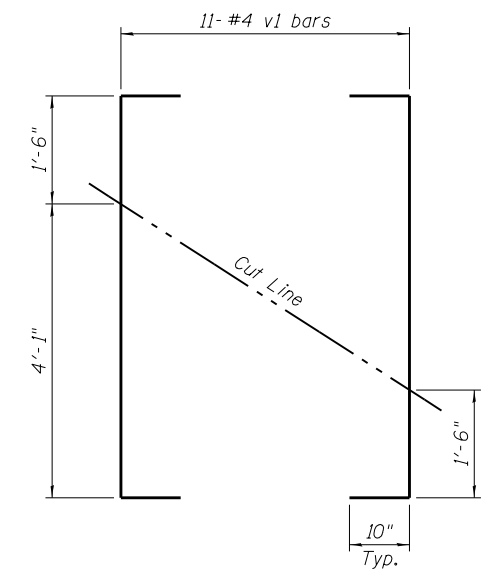

**CUTTING DIAGRAM**

Order bars full length. Cut as shown and use remainder of bars in opposite wall.

**BILL OF MATERIAL**  
(For Information Only)

Bar	No.	Size	Length	Shape
a1	38	#6	6'-0"	
a2	24	#4	4'-8"	
d	6	#4	4'-6"	
h	7	#6	4'-0"	
h1	10	#4	15'-8"	
h2	8	#5	14'-4"	
h3	12	#6	4'-8"	
h4	2	#5	9'-1"	
h5	6	#5	2'-8"	
h6	8	#6	2'-3"	
s	5	#4	3'-0"	
s1	5	#4	3'-3"	
s2	6	#4	3'-9"	
v	20	#4	4'-7"	
v1	11	#4	7'-3"	
Description		Unit	Quantity	
Concrete Box Culverts		Cu. Yd.	4.0	
Reinforcement Bars		Pound	1,000	