

ROUTE		SECTION	COUNTY	SHEET	
MKD.	FAP	103 RS-3	PEORIA	TOTAL	NO.
IL 90	661			21	8

D-94-068-02
CONTRACT # 68259

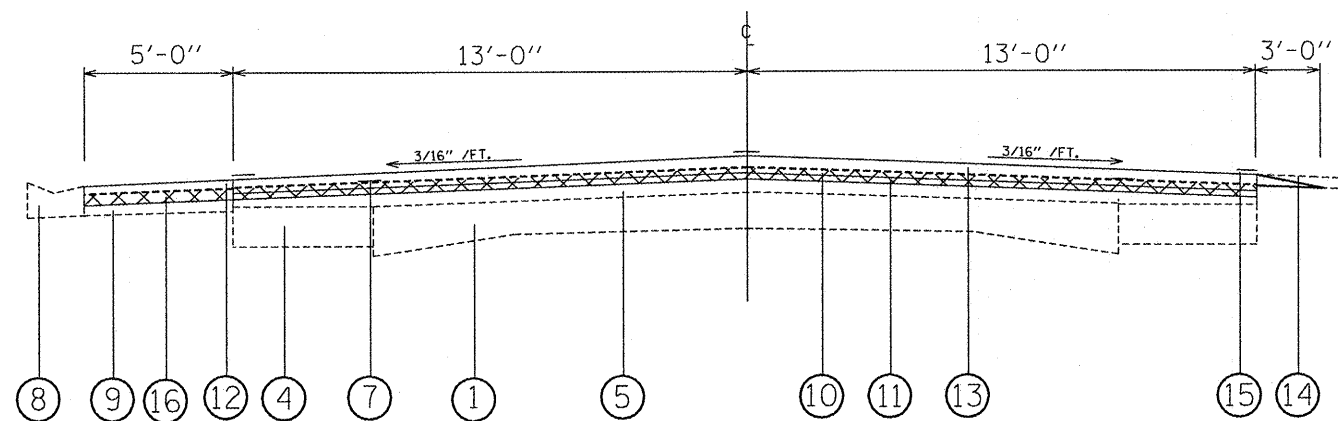

TYPICAL SECTION NO. 5
STA. 107+00 TO STA. 109+60

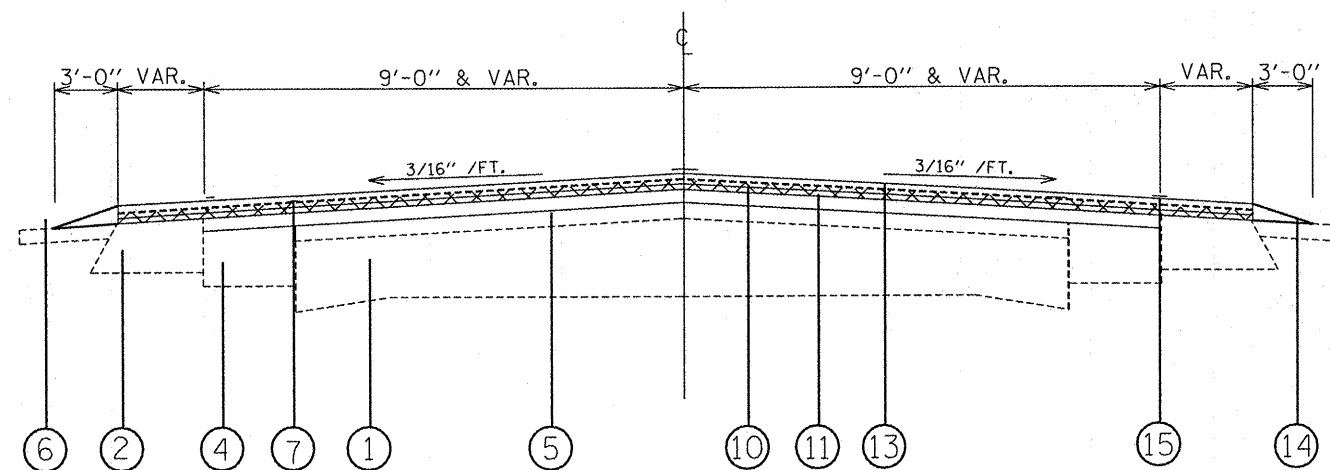

TYPICAL SECTION NO. 6
STA. 136+46.6 TO STA. 137+71 (RT.)
STA. 136+43.3 TO STA. 137+71 (LT.)

LEGEND

- ① EXISTING 9"-6"-9" PCC PAVEMENT
- ② EXISTING 9" HOT MIX ASPHALT BASE COURSE
- ③ EXISTING PCC BASE COURSE 8"
- ④ EXISTING 9" HOT MIX ASPHALT BASE COURSE WIDENING
- ⑤ EXISTING HOT MIX ASPHALT OVERLAYS
- ⑥ EXISTING 6" AGGREGATE SHOULDER TYPE B
- ⑦ EXISTING STRIP REFLECTIVE CRACK CONTROL
- ⑧ EXISTING CONCRETE GUTTER TYPE A
- ⑨ EXISTING 8" HOT MIX ASPHALT SHOULDER
- ⑩ PROPOSED HOT-MIX ASPHALT REMOVAL, COLD MILL 1 1/2 "
- ⑪ PROPOSED POLYMERIZED LEVELING BINDER COURSE, 3/4 "
- ⑫ PROPOSED HOT-MIX ASPHALT SURFACE COURSE, MIX C N30 VARIABLE DEPTH 1 1/2 " TO 2 1/4 "
- ⑬ PROPOSED POLYMERIZED HOT-MIX ASPHALT SURFACE COURSE, MIX D N50, 1 1/2 "
- ⑭ PROPOSED AGGREGATE SHOULDER TYPE B
- ⑮ PROPOSED EPOXY PAVEMENT MARKINGS
- ⑯ PROPOSED HOT-MIX ASPHALT REMOVAL, VARIABLE DEPTH 1/2" TO 1 1/2"

ILLINOIS DEPARTMENT OF TRANSPORTATION
TYPICAL SECTIONS
IL 90
NOT TO SCALE