

PAVEMENT MARKING LEGEND

- 1 4" (100) SKIP-DASH (YELLOW)
- 2 4" (100) SOLID (YELLOW)
- 3 12" (300) DIAGONAL (YELLOW)
- 4 4" (100) DOUBLE YELLOW (NARROW)
- 5 12" (300) SOLID WHITE *NOTE: CROSS WALKS SHALL BE MODIFIED URETHANE AND WILL NOT BE GROOVED IN
- 6 RESERVED
- 7 6" (150) SKIP-DASH (WHITE)
- 8 4" (100) SOLID (WHITE)
- 10 6" (150) SOLID (WHITE)
- 11 24" (600) STOP BAR (WHITE)

TYPICAL PAVEMENT MARKERS LEGEND

- TWO-WAY AMBER MARKER
- ONE-WAY AMBER MARKER
- ONE-WAY CRYSTAL MARKER

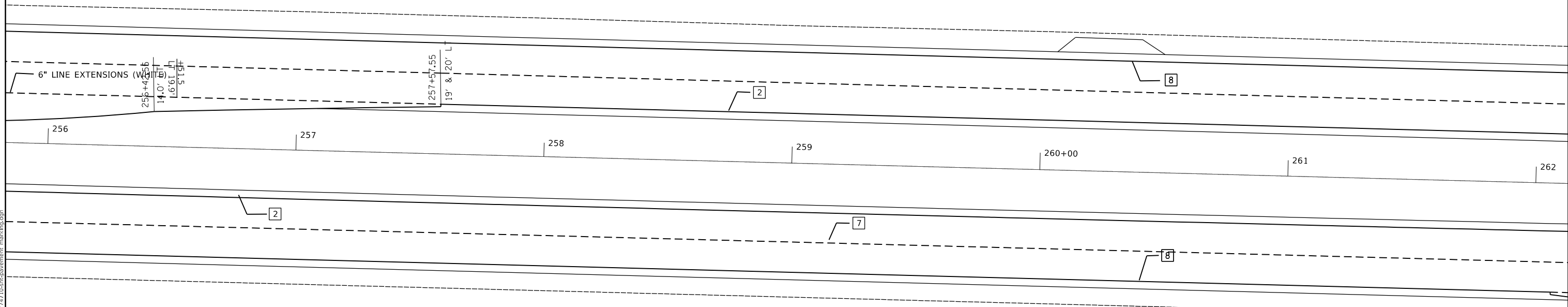

MODEL: Default
 FILE: \\bls1c1.pw\pub\aroom\dat\illinois.gov\PW\DOT\Documents\DOT_Offices\District_7\Projects\74710\CAD\Drawings\74710-Subpavement_marking.dgn

USER NAME = steffenmk	DESIGNED -	REVISED -
	DRAWN -	REVISED -
PLOT SCALE = 40.0000 ' / in.	CHECKED -	REVISED -
PLOT DATE = 2/20/2020	DATE -	REVISED -

STATE OF ILLINOIS
DEPARTMENT OF TRANSPORTATION

PAVEMENT MARKING DETAILS
U.S. 36

SCALE: 20 SHEET 30 OF 38 SHEETS STA. 256+00 TO STA. 262+00

F.A.P. RTE.	SECTION	COUNTY	TOTAL SHEETS	SHEET NO.
*	(137z, 139-X-2)RS-2	MACON	262	201
*F.A.P. RTE. 320, 323, 323A		CONTRACT NO. 74710		
ILLINOIS FED. AID PROJECT				

MODEL: Default
 FILE: \\bls01\p\pub\blsroom\dat\illinois\p\p\WID\DOT\Documents\IBDOT_Offices\District_7\Projects\74710\CADD\DATA\CAD\Sheet\74710-51-31-pavement_marking.dwg

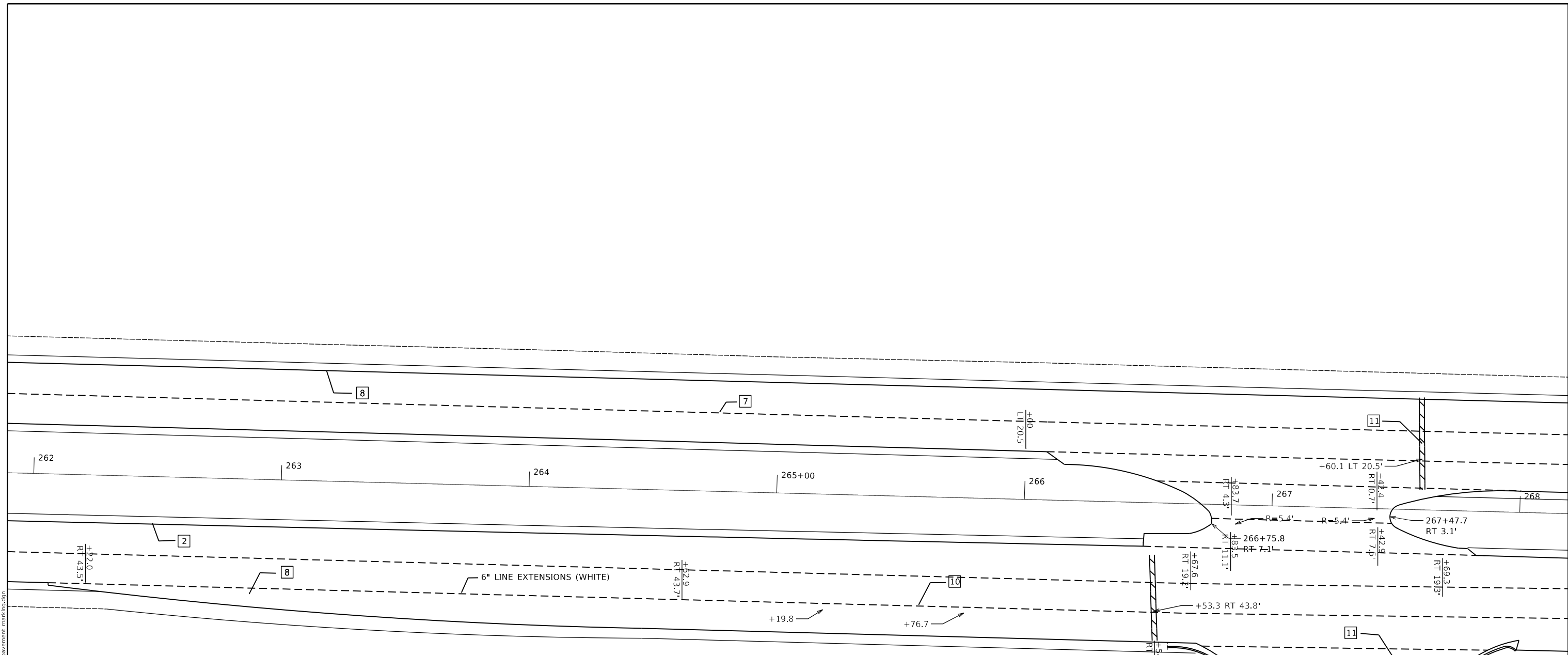

PAVEMENT MARKING LEGEND

- 1 4" (100) SKIP-DASH (YELLOW)
- 2 4" (100) SOLID (YELLOW)
- 3 12" (300) DIAGONAL (YELLOW)
- 4 4" (100) DOUBLE YELLOW (NARROW)
- 5 12" (300) SOLID WHITE *NOTE: CROSS WALKS SHALL BE MODIFIED URETHANE AND WILL NOT BE GROOVED IN
- 6 RESERVED
- 7 6" (150) SKIP-DASH (WHITE)
- 8 4" (100) SOLID (WHITE)
- 10 6" (150) SOLID (WHITE)
- 11 24" (600) STOP BAR (WHITE)

TYPICAL PAVEMENT MARKERS LEGEND

- ◆ TWO-WAY AMBER MARKER
- ▶ ONE-WAY AMBER MARKER
- ▷ ONE-WAY CRYSTAL MARKER

USER NAME = steffenmk	DESIGNED -	REVISED -
	DRAWN -	REVISED -
PLOT SCALE = 40.0000 ' / in.	CHECKED -	REVISED -
PLOT DATE = 2/20/2020	DATE -	REVISED -

STATE OF ILLINOIS
DEPARTMENT OF TRANSPORTATION

PAVEMENT MARKING DETAILS
U.S. 36

SCALE: 20 SHEET 31 OF 38 SHEETS STA. 262+00 TO STA. 268+00

F.A.P. RTE.	SECTION	COUNTY	TOTAL SHEETS	SHEET NO.
*	(137z, 139-X-2)RS-2	MACON	262	202
*F.A.P. RTE. 320, 323, 323A		CONTRACT NO. 74710		
ILLINOIS FED. AID PROJECT				

PAVEMENT MARKING LEGEND

- [1] 4" (100) SKIP-DASH (YELLOW)
- [2] 4" (100) SOLID (YELLOW)
- [3] 12" (300) DIAGONAL (YELLOW)
- [4] 4" (100) DOUBLE YELLOW (NARROW)
- [5] 12" (300) SOLID WHITE *NOTE: CROSS WALKS SHALL BE MODIFIED URETHANE AND WILL NOT BE GROOVED IN
- [6] RESERVED
- [7] 6" (150) SKIP-DASH (WHITE)
- [8] 4" (100) SOLID (WHITE)
- [10] 6" (150) SOLID (WHITE)
- [11] 24" (600) STOP BAR (WHITE)

TYPICAL PAVEMENT MARKERS LEGEND

- ◆ TWO-WAY AMBER MARKER
- ONE-WAY AMBER MARKER
- ▷ ONE-WAY CRYSTAL MARKER

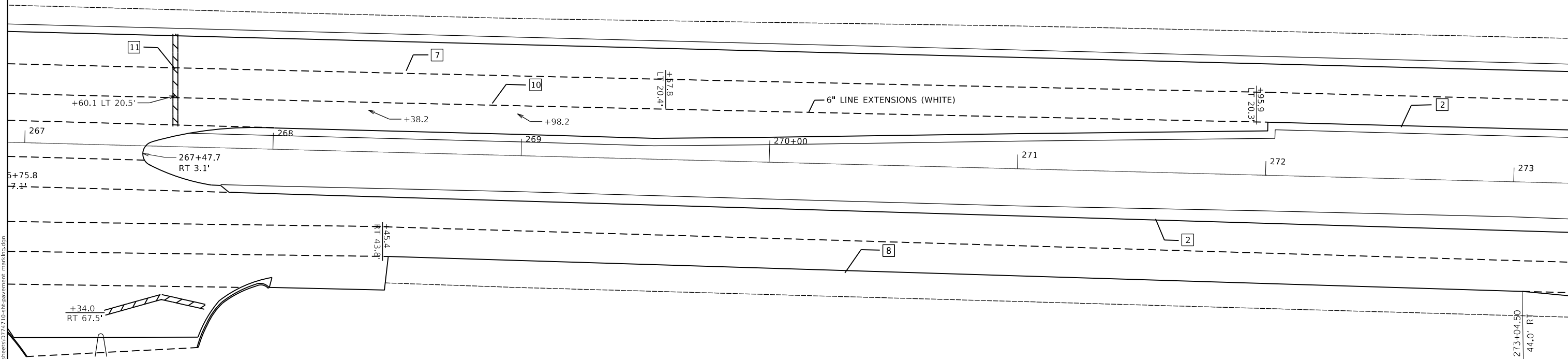

MODEL: Default
FILE: h:\mhc\pww\pwwroom\dat\illinois\pww\pwwdot\Documents\DOT_Offices\Director_7\Projects\74710\CADD\Drawings\DOT_Offices\Director_7\Projects\74710\pws\pavement_marking.dwg

USER NAME = steffenmk	DESIGNED -	REVISED -
	DRAWN -	REVISED -
PLOT SCALE = 40.0000 ' / in.	CHECKED -	REVISED -
PLOT DATE = 2/20/2020	DATE -	REVISED -

STATE OF ILLINOIS
DEPARTMENT OF TRANSPORTATION

PAVEMENT MARKING DETAILS		
U.S. 36		
SCALE: 20	SHEET 32 OF 38 SHEETS	STA. 268+00 TO STA. 273+00

F.A.P. RTE.	SECTION	COUNTY	TOTAL SHEETS	SHEET NO.
*	(137z, 139-X-2)RS-2	MACON	262	203
*F.A.P. RTE. 320, 323, 323A		CONTRACT NO. 74710		
ILLINOIS FED. AID PROJECT				

PAVEMENT MARKING LEGEND

- 1 4" (100) SKIP-DASH (YELLOW)
- 2 4" (100) SOLID (YELLOW)
- 3 12" (300) DIAGONAL (YELLOW)
- 4 4" (100) DOUBLE YELLOW (NARROW)
- 5 12" (300) SOLID WHITE *NOTE: CROSS WALKS SHALL BE MODIFIED URETHANE AND WILL NOT BE GROOVED IN
- 6 RESERVED
- 7 6" (150) SKIP-DASH (WHITE)
- 8 4" (100) SOLID (WHITE)
- 10 6" (150) SOLID (WHITE)
- 11 24" (600) STOP BAR (WHITE)

TYPICAL PAVEMENT MARKERS LEGEND

- ◆ TWO-WAY AMBER MARKER
- ▶ ONE-WAY AMBER MARKER
- ▷ ONE-WAY CRYSTAL MARKER

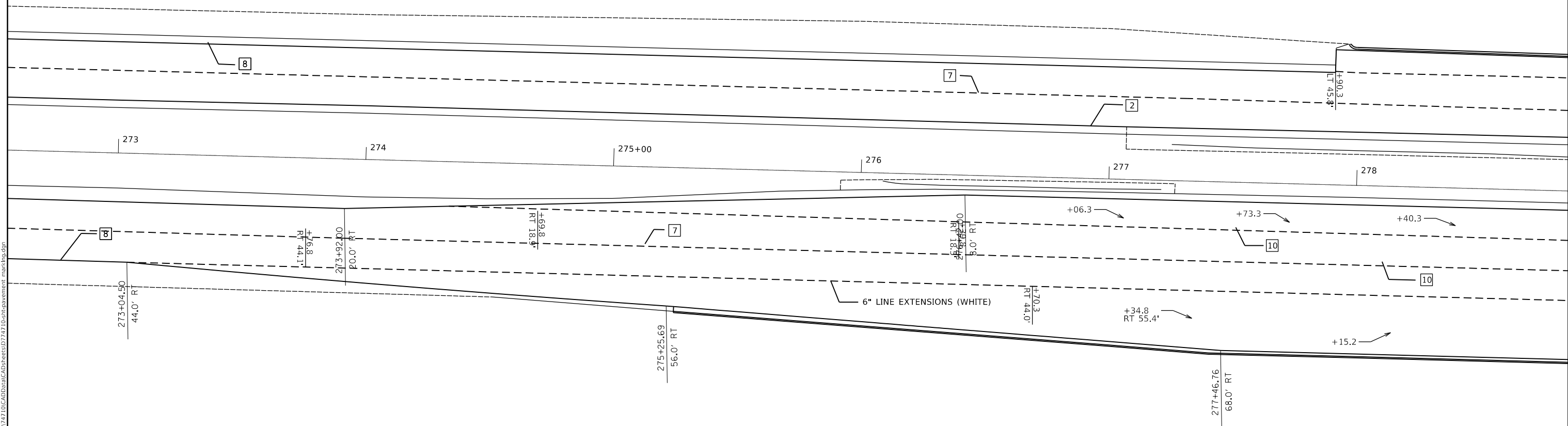

MODEL: Default
 FILE: \\bls01c.pw.uspbarn.com\data\illinois.gov\PWIDOT\Documents\DOT_Offices\District_7\Projects\74710\CAAD\Drawings\74710-Sub-Pavement_Markings.dwg

USER NAME = steffenmk	DESIGNED -	REVISED -
	DRAWN -	REVISED -
PLOT SCALE = 40.0000 ' / in.	CHECKED -	REVISED -
PLOT DATE = 2/20/2020	DATE -	REVISED -

STATE OF ILLINOIS
DEPARTMENT OF TRANSPORTATION

PAVEMENT MARKING DETAILS			
U.S. 36			
SCALE: 20	SHEET 33	OF 38 SHEETS	STA. 273+00 TO STA. 278+00

F.A.P. RTE.	SECTION	COUNTY	TOTAL SHEETS	SHEET NO.
*	(137z, 139-X-2)RS-2	MACON	262	204
*F.A.P. RTE. 320, 323, 323A		CONTRACT NO. 74710		
ILLINOIS FED. AID PROJECT				

TYPICAL PAVEMENT MARKERS LEGEND

- ◆ TWO-WAY AMBER MARKER
- ▶ ONE-WAY AMBER MARKER
- ▷ ONE-WAY CRYSTAL MARKER

PAVEMENT MARKING LEGEND

- 1 4" (100) SKIP-DASH (YELLOW)
 - 2 4" (100) SOLID (YELLOW)
 - 3 12" (300) DIAGONAL (YELLOW)
 - 4 4" (100) DOUBLE YELLOW (NARROW)
 - 5 12" (300) SOLID WHITE
 - 6 RESERVED
 - 7 6" (150) SKIP-DASH (WHITE)
 - 8 4" (100) SOLID (WHITE)
 - 9 12" (300) DIAGONAL (WHITE)
 - 10 6" (150) SOLID (WHITE)
 - 11 24" (600) STOP BAR (WHITE)
 - 12 8" (200) SOLID (WHITE)
-

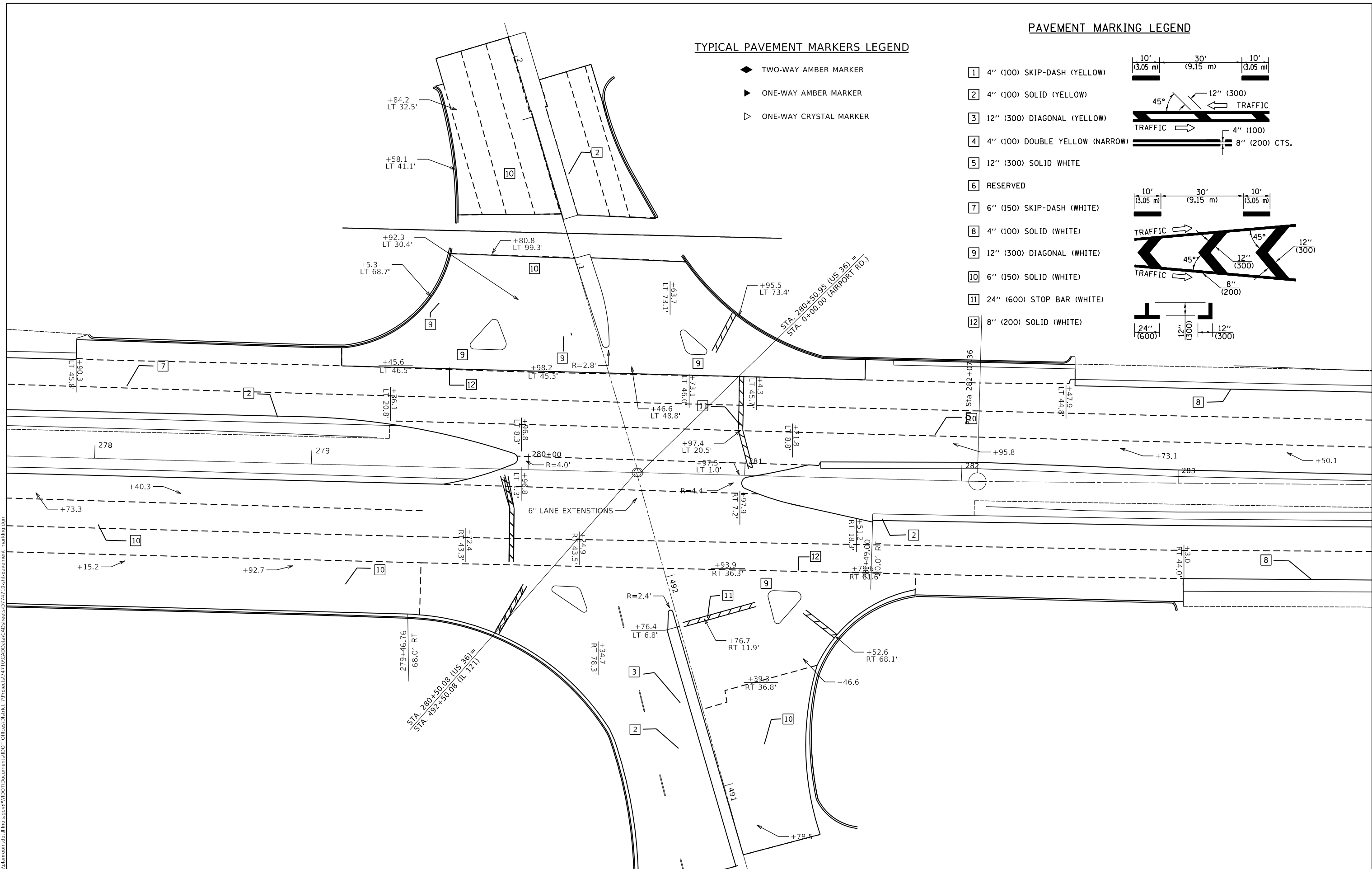

MODEL: Default
 FILE: \\blm\c:\pub\planroom\dat\illinois\gov\pww\dot\Documents\DOT_Offices\Drawings\7\Projects\71710\CADD\Drawings\DOT\71710-Subpavement_marking.dwg
 DATE: 2/20/2020

USER NAME = steffnmk	DESIGNED -	REVISED -
	DRAWN -	REVISED -
PLOT SCALE = 40.0000' / in.	CHECKED -	REVISED -
PLOT DATE = 2/20/2020	DATE -	REVISED -

STATE OF ILLINOIS
DEPARTMENT OF TRANSPORTATION

PAVEMENT MARKING DETAILS
U.S. 36









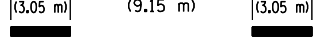

SCALE: 20 SHEET 34 OF 38 SHEETS STA. 278+00 TO STA. 283+00

F.A.P. RTE.	SECTION	COUNTY	TOTAL SHEETS	SHEET NO.
*	(137z, 139-X-2)RS-2	MACON	262	205
*F.A.P. RTE. 320, 323, 323A			CONTRACT NO. 74710	
ILLINOIS FED. AID PROJECT				

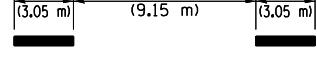
PAVEMENT MARKING LEGEND

TYPICAL PAVEMENT MARKERS LEGEND

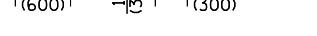
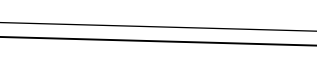
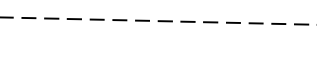
- ◆ TWO-WAY AMBER MARKER
- ▶ ONE-WAY AMBER MARKER
- ▷ ONE-WAY CRYSTAL MARKER

- 1 4" (100) SKIP-DASH (YELLOW) 
- 2 4" (100) SOLID (YELLOW) 
- 3 12" (300) DIAGONAL (YELLOW) 
- 4 4" (100) DOUBLE YELLOW (NARROW) 
- 5 12" (300) SOLID WHITE 
- 6 RESERVED
- 7 6" (150) SKIP-DASH (WHITE) 
- 8 4" (100) SOLID (WHITE) 
- 9 12" (300) DIAGONAL (WHITE) 
- 10 6" (150) SOLID (WHITE) 
- 11 24" (600) STOP BAR (WHITE) 
- 12 8" (200) SOLID (WHITE) 
- 13 4" (100) PARKING WHITE 

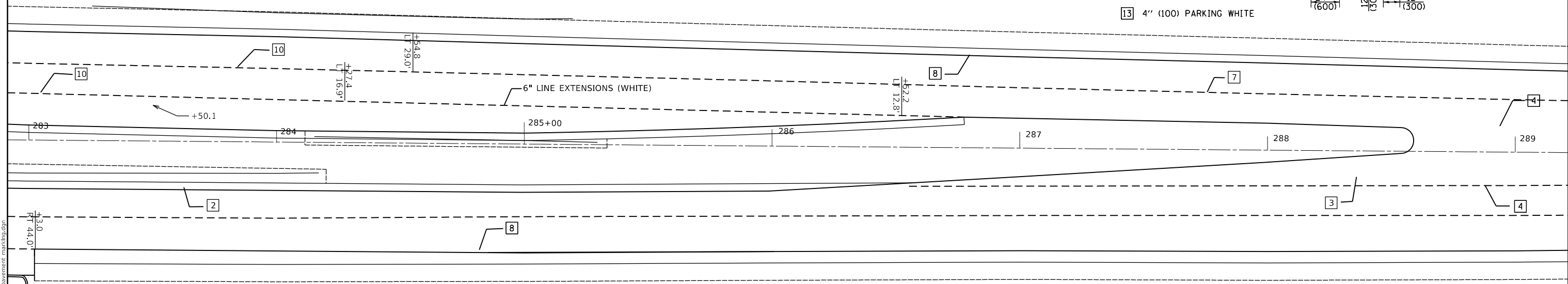

MODEL: Default
 FILE: h:\mfc_pavement\pavement\pavement.mxd
 PROJECT: 74710\CADD\pavement\pavement.mxd
 DATE: 2/20/2020

USER NAME = steffemk	DESIGNED -	REVISED -
PLOT SCALE = 40,0000 ' / in.	DRAWN -	REVISID -
PLOT DATE = 2/20/2020	CHECKED -	REVISID -
	DATE -	REVISID -

STATE OF ILLINOIS
DEPARTMENT OF TRANSPORTATION

PAVEMENT MARKING DETAILS
U.S. 36

SCALE: 20 SHEET 35 OF 38 SHEETS STA. 283+00 TO STA. 289+00

F.A.P. RTE.	SECTION	COUNTY	TOTAL SHEETS	SHEET NO.
137z, 139-X-2	RS-2	MACON	262	206
*F.A.P. RTE. 320, 323, 323A			CONTRACT NO. 74710	
ILLINOIS FED. AID PROJECT				

PAVEMENT MARKING LEGEND

- 1 4" (100) SKIP-DASH (YELLOW)
- 2 4" (100) SOLID (YELLOW)
- 3 12" (300) DIAGONAL (YELLOW)
- 4 4" (100) DOUBLE YELLOW (NARROW)
- 5 12" (300) SOLID WHITE
- 6 RESERVED
- 7 6" (150) SKIP-DASH (WHITE)
- 8 4" (100) SOLID (WHITE)
- 9 12" (300) DIAGONAL (WHITE)
- 10 6" (150) SOLID (WHITE)
- 11 24" (600) STOP BAR (WHITE)
- 12 8" (200) SOLID (WHITE)
- 13 4" (100) PARKING WHITE

TYPICAL PAVEMENT MARKERS LEGEND

- TWO-WAY AMBER MARKER
- ONE-WAY AMBER MARKER
- ONE-WAY CRYSTAL MARKER

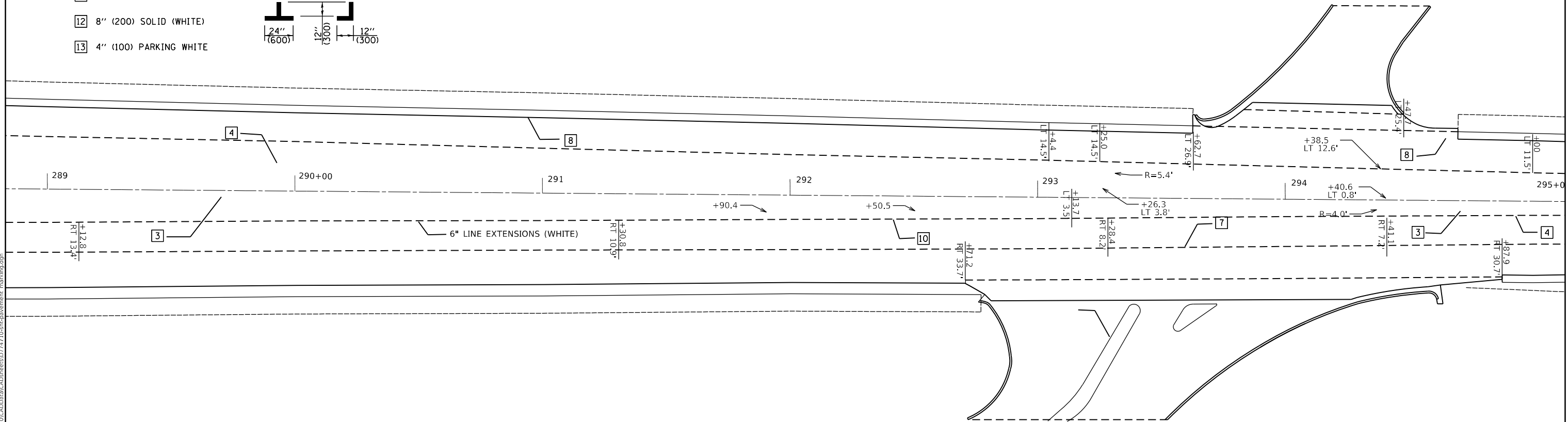

MODEL: Default
 FILE: \\blm1c:\pub\planroom\dat\illinois\pav\pww\DOT\Documents\IBDOT_Offices\IBDOT_7\Projects\74710\CAAD\BataCAD\Drawings\74710-5-10-pavement_marking.dwg

USER NAME = steffemk	DESIGNED -	REVISED -
	DRAWN -	REVISED -
PLOT SCALE = 40.0000 ' / in.	CHECKED -	REVISED -
PLOT DATE = 2/20/2020	DATE -	REVISED -









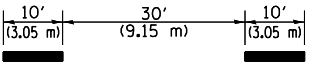
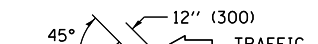

STATE OF ILLINOIS
DEPARTMENT OF TRANSPORTATION

PAVEMENT MARKING DETAILS
U.S. 36

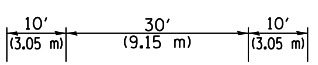

SCALE: 20 SHEET 36 OF 38 SHEETS STA. 289+00 TO STA. 295+00

F.A.P. RTE.	SECTION	COUNTY	TOTAL SHEETS	SHEET NO.
*	(137z, 139-X-2)RS-2	MACON	262	207
*F.A.P. RTE. 320, 323, 323A		CONTRACT NO. 74710		
ILLINOIS FED. AID PROJECT				

PAVEMENT MARKING LEGEND

- 1 4" (100) SKIP-DASH (YELLOW) 
- 2 4" (100) SOLID (YELLOW) 
- 3 12" (300) DIAGONAL (YELLOW) 
- 4 4" (100) DOUBLE YELLOW (NARROW) 
- 5 12" (300) SOLID WHITE 
- 6 RESERVED
- 7 6" (150) SKIP-DASH (WHITE) 
- 8 4" (100) SOLID (WHITE) 
- 9 12" (300) DIAGONAL (WHITE) 
- 10 6" (150) SOLID (WHITE) 
- 11 24" (600) STOP BAR (WHITE) 
- 12 8" (200) SOLID (WHITE) 
- 13 4" (100) PARKING WHITE 

TYPICAL PAVEMENT MARKERS LEGEND

-  TWO-WAY AMBER MARKER
-  ONE-WAY AMBER MARKER
-  ONE-WAY CRYSTAL MARKER

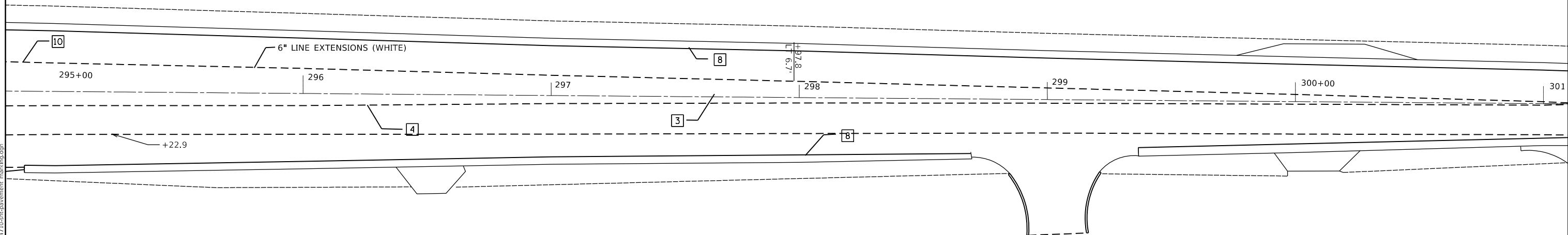

MODEL: Default
 FILE: h:\m\c\p\supl\room\dat\illinois.gov\RWIDOT\Documents\IBOT_Offices\IBOT\7\Projects\74710\CAAD\BataCAD\Drawings\74710-10-10-pavement_msk.dwg

USER NAME = steffenmk	DESIGNED -	REVISED -
PLOT SCALE = 40.0000 ' / in.	DRAWN -	REVISED -
PLOT DATE = 2/20/2020	CHECKED -	REVISED -
	DATE -	REVISED -

STATE OF ILLINOIS
DEPARTMENT OF TRANSPORTATION

PAVEMENT MARKING DETAILS
U.S. 36



SCALE: 20 SHEET 37 OF 38 SHEETS STA. 295+00 TO STA. 301+00

F.A.P. RTE.	SECTION	COUNTY	TOTAL SHEETS	SHEET NO.
*	(137z, 139-X-2)RS-2	MACON	262	208
*F.A.P. RTE. 320, 323, 323A		CONTRACT NO. 74710		
ILLINOIS FED. AID PROJECT				

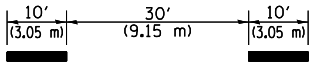
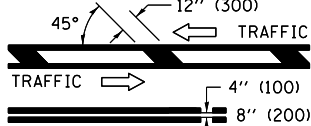
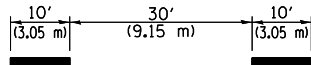
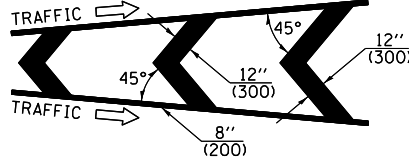
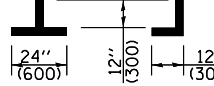
PAVEMENT MARKING LEGEND

- 1 4" (100) SKIP-DASH (YELLOW) 
- 2 4" (100) SOLID (YELLOW)
- 3 12" (300) DIAGONAL (YELLOW) 
- 4 4" (100) DOUBLE YELLOW (NARROW)
- 5 12" (300) SOLID WHITE
- 6 RESERVED
- 7 6" (150) SKIP-DASH (WHITE) 
- 8 4" (100) SOLID (WHITE) 
- 9 12" (300) DIAGONAL (WHITE)
- 10 6" (150) SOLID (WHITE)
- 11 24" (600) STOP BAR (WHITE) 
- 12 8" (200) SOLID (WHITE)
- 13 4" (100) PARKING WHITE

TYPICAL PAVEMENT MARKERS LEGEND

-  TWO-WAY AMBER MARKER
-  ONE-WAY AMBER MARKER
-  ONE-WAY CRYSTAL MARKER

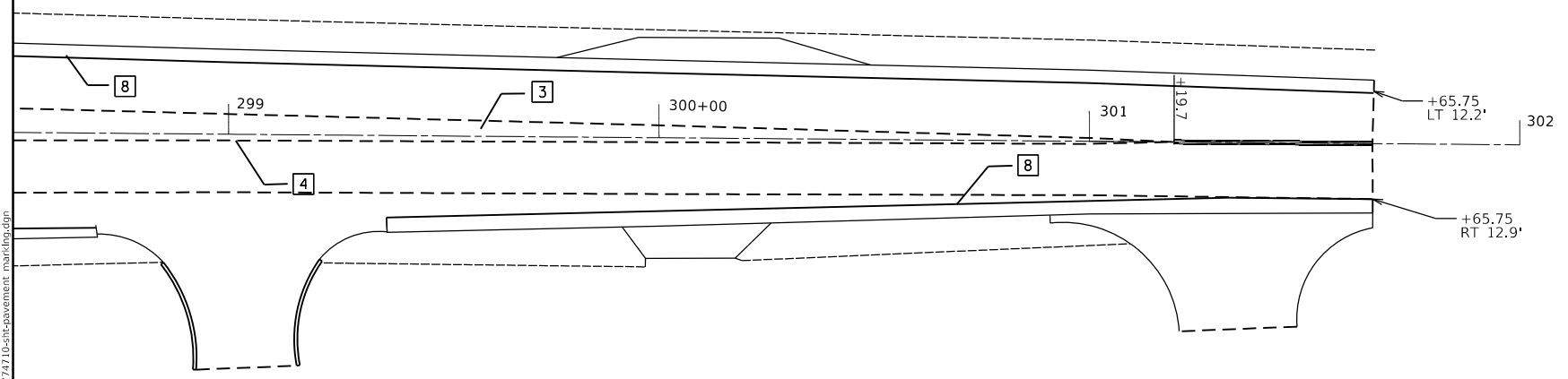

MODEL: Default
 FILE: h:\mktc_pav\pub\harron\m.d\illinois.gov\RWIDOT\Documents\DOT_Offices\District_7\Projects\74710\CAAD\BakCAD\Drawings\74710-510-pavement_marking.dwg

USER NAME = steffenmk	DESIGNED -	REVISED -
	DRAWN -	REVISED -
PLOT SCALE = 40.0000 ' / in.	CHECKED -	REVISED -
PLOT DATE = 2/20/2020	DATE -	REVISED -

STATE OF ILLINOIS
DEPARTMENT OF TRANSPORTATION

PAVEMENT MARKING DETAILS			
U.S. 36			
SCALE: 20	SHEET 38	OF 38 SHEETS	STA. 301+00 TO STA. 301+65.75

F.A.P. RTE.	SECTION	COUNTY	TOTAL SHEETS	SHEET NO.
*	(137z, 139-X-2)RS-2	MACON	262	209
*F.A.P. RTE. 320, 323, 323A		CONTRACT NO. 74710		
ILLINOIS FED. AID PROJECT				

TRAFFIC SIGNAL GENERAL NOTES

THIS TRAFFIC SIGNAL PORTION OF THIS PROJECT CONSISTS OF TRAFFIC SIGNAL MODERNIZATION AT 4 SEPARATE INTERSECTIONS ALONG US RTE 36. (US 36 AND 22ND STREET, US 36 AND PRAIRIE STREET, US36 AND WOOD & NELSON STREETS, US 36 AND 27TH STREET), ALSO REPLACING THE LOOPS ACROSS THE RR AT US 36 & COUNTY CLUB ROAD, 44TH STREET AND AIRPORT ROAD. ALL IN THE CITY OF DECATUR MACON COUNTY. THE WORK INCLUDED IN THIS SECTION CONSISTS OF INSTALLING TRAFFIC SIGNALS AND ALL OTHER WORK NECESSARY TO COMPLETE THIS PORTION OF THIS PROJECT.

THE EXISTING UTILITY LINES ARE SHOWN ON THE PLANS TO INDICATE THEIR PRESENCE AND APPROXIMATE LOCATION. THE CONTRACTOR SHALL VERIFY THE EXACT LOCATION OF ALL UNDERGROUND UTILITIES PRIOR TO BEGINNING CONSTRUCTION. CALL J.U.L.I.E. AT 1-800-892-0123. THE TRAFFIC SIGNAL UTILITY LINES WILL BE LOCATED BY IDOT, CALL 217-342-3951.

THE TRAFFIC SIGNAL ENGINEER AT THE ILLINOIS DEPARTMENT OF TRANSPORTATION JOSH PORTER SHALL BE NOTIFIED AT 217-342-5677 AT LEAST 72 HOURS PRIOR TO TURNING ON ANY FLASHER OR CONTROLLER UNIT AND 48 HOURS PRIOR TO ANY SIGNAL ADJUSTMENTS.

THE SIZE OF THE CABLE SUPPLIED SHALL BE EQUAL TO OR GREATER THAN THE SIZE OF THE CABLE REQUIRED TO CARRY THE LOAD BETWEEN THE CONTROLLER AND THE SERVICE INSTALLATION.

THE CONTRACTOR SHALL ARRANGE FOR A FACTORY OR SUPPLIER REPRESENTATIVE TO BE PRESENT AT THE INTERSECTION WHEN THE SIGNALS ARE TURNED ON. THE REPRESENTATIVE SHALL MAKE CERTAIN THAT ALL EQUIPMENT OPERATES TO THE SATISFACTION OF THE ENGINEER.

A 2 FOOT MINIMUM, 6 FOOT DESIRABLE, HORIZONTAL CLEARANCE SHALL BE MAINTAINED FROM THE BACK OF CURB TO THE EDGE OF HANDHOLES, JUNCTION BOXES AND SIGNAL POST FOUNDATIONS. A 5 FOOT MINIMUM HORIZONTAL CLEARANCE SHALL BE MAINTAINED FROM THE BACK OF THE CURB TO ALL MAST ARM FOUNDATIONS. CONTROLLER FOUNDATIONS SHALL BE LOCATED AS FAR FROM THE BACK OF THE CURB AS POSSIBLE TO PROTECT THE CONTROLLER CABINET.

ALL HARDWARE SHALL BE TIGHTENED AND WELL SECURED. CABLES SHALL BE NEATLY WOUND IN HANDHOLES. CABLES SHALL BE NEATLY TRAINED IN THE CONTROLLER CABINET.

ALL THREADS OF BOLTS USED IN ASSEMBLY OF TRAFFIC SIGNAL COMPONENTS SHALL BE COATED WITH A NON- LEAD BASED ANTI -SEIZE COMPOUND, SIMILAR TO LEAD PLATE, PRIOR TO ASSEMBLY.

NO ADDITIONAL COMPENSATION WILL BE ALLOWED FOR PLACING CONDUIT AT GREATER THAN 2 FOOT MINIMUM DEPTH TO AVOID OBSTACLES SUCH AS UNDERGROUND UTILITIES.

THE CONTRACTOR IS RESPONSIBLE FOR UNCOVERING OR HAND DIGGING AROUND UTILITIES AS NECESSARY. THE COST OF THIS WORK IS TO BE INCLUDED WITH THE ELECTRICAL WORK PAY ITEM.

THE NUMBER OF CONDUCTORS FOR ELECTRIC CABLES AS SHOWN ON THE PLANS SHALL BE THE MINIMUM NUMBER OF CONDUCTORS FURNISHED FOR EACH LOCATION. THE CONTRACTOR MAY SUBSTITUTE AN ELECTRIC CABLE WITH MORE CONDUCTORS THAN SPECIFIED BUT NO ADDITIONAL COMPENSATION WILL BE MADE FOR THE EXTRA CONDUCTORS.

ALL NEW TRAFFIC SIGNAL WIRING SHALL EXTEND FROM CONTROLLER TO SIGNAL. SPLICES IN HANDHOLES WILL NOT BE ALLOWED.

ALL MAST ARM MOUNTED SIGNAL HEADS ON AN INDIVIDUAL MAST ARM SHALL BE MOUNTED SO THAT THE RED INDICATIONS ARE LEVEL WITH EACH OTHER.

ALL MAST ARM MOUNTED SIGNAL HEADS SHALL BE MOUNTED AS TO ALIGN WITH THE CENTER OF THE LANE UNLESS OTHERWISE SHOWN ON THE PLANS.

12" LENSES WILL BE USED ON ALL SIGNAL FACES.

TRAFFIC SIGNAL HEADS SHALL BE PROPERLY COVERED PRIOR TO INTERSECTION TURN -ON OR AS DIRECTED BY THE ENGINEER. THIS COST SHALL BE INCLUDED WITH THE COST OF THE ASSOCIATED SIGNAL HEAD PAY ITEMS.

ALL TRAFFIC SIGNAL MAST ARM ASSEMBLIES (STANDARD, COMBINATION, OR DUAL) MUST BE DESIGNED FOR THE LOADINGS SHOWN ON THE HIGHWAY STANDARDS OR THESE SIGNAL PLANS, WHICHEVER IS GREATER.

THE STATION AND OFFSET SHOWN FOR THE ITEMS TO BE INSTALLED IS THE STATION AND DISTANCE TO THE CENTER OF THE ITEM.

THE EMERGENCY VEHICLE PRE-EMPTION EQUIPMENT, MOUNTING HARDWARE AND WIRING WILL BE SUPPLIED BY THE CITY OF DECATUR. THE INSTALLATION WILL BE DONE BY THE CONTRACTOR.

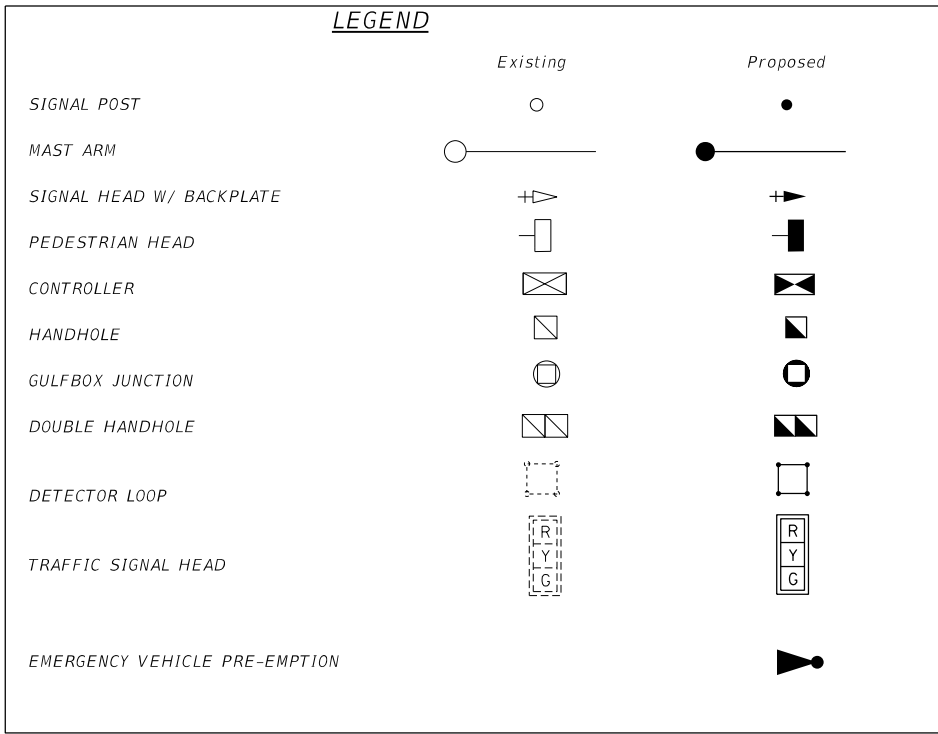

NUMBER OF TURNS REQUIRED IN DETECTOR LOOPS

6 X 6		6 X 30		6 X 40		LOOP SIZE
		0	491	0	627	2 TURNS
			492	628	1255	3 TURNS
0	545	983	1636	1256	2091	4 TURNS
546	818	1637	2455	2092	3136	5 TURNS
819	1145	2456	3436			6 TURNS
1146	1527					7 TURNS
1528	1964					8 TURNS
1965	2455					9 TURNS
2456	3000					10 TURNS

Distance from the Controller Cabinet

MODEL: Default
FILE: \\blm1c:\pub\lhamon\m.d\illinois.gov\pww\DOT\Documents\IDOT_Offices\IDOT\7\Projects\74710\CADD\Drawings\IDOT\74710_T54526 & 22nd_St.dgn

USER NAME = steffenmk	DESIGNED -	REVISED -
	DRAWN -	REVISED -
PLOT SCALE = 19.9998 ' / in.	CHECKED -	REVISED -
PLOT DATE = 2/20/2020	DATE -	REVISED -

**STATE OF ILLINOIS
DEPARTMENT OF TRANSPORTATION**

**INTERSECTIONS OF US 36
GENERAL NOTES AND DETAILS**

SCALE: SHEET OF SHEETS STA. TO STA.

F.A.P. RTE.	SECTION	COUNTY	TOTAL SHEETS	SHEET NO.
320	(137Z, 139-X-2)RS-2	MACON	262	210
CONTRACT NO. 74710				
ILLINOIS FED. AID PROJECT				

FIBER OPTIC INTERCONNECT

FROM 22nd ST TO 27th ST

The proposed Fiber Optic Interconnect will be installed from the controller cabinet at 22nd St to each controller cabinet along US 36 and ending at 27th St. The Master Controller will be installed in the proposed cabinet at 22nd St. Locations as shown for the existing conduit and handholes along the interconnect from 22nd St to Wood and Nelson St. were obtained from existing plans not field measurements. Final locations and lengths will be determined in the field.

The Existing Fiber Optic Interconnect wiring 62.5/125 6F FO will be pulled from 22nd St to Wood & Nelson St and new 62.5/125 6F FO will be installed. Final locations and lengths will be determined in the field.

New Fiber Optic Interconnect wiring 62.5/125 6F FO and conduit will be installed from Wood & Nelson St to 27th St. Final locations and lengths will be determined in the field.

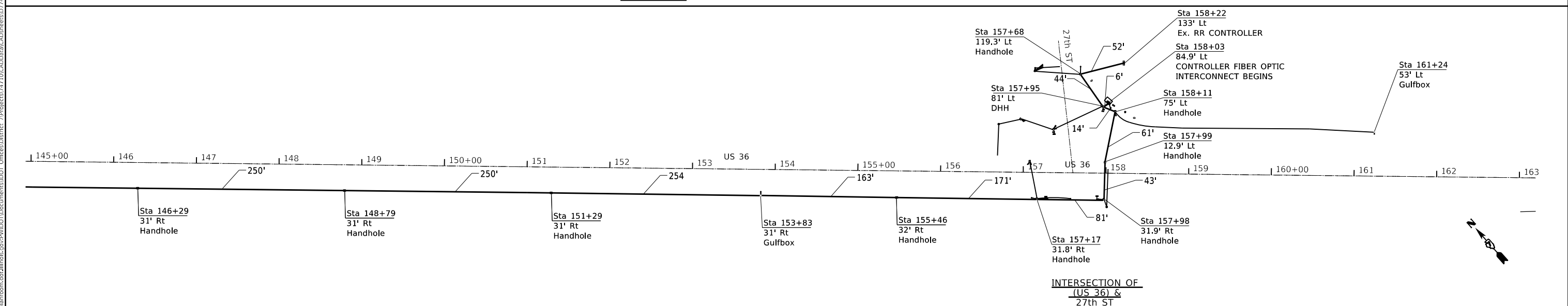
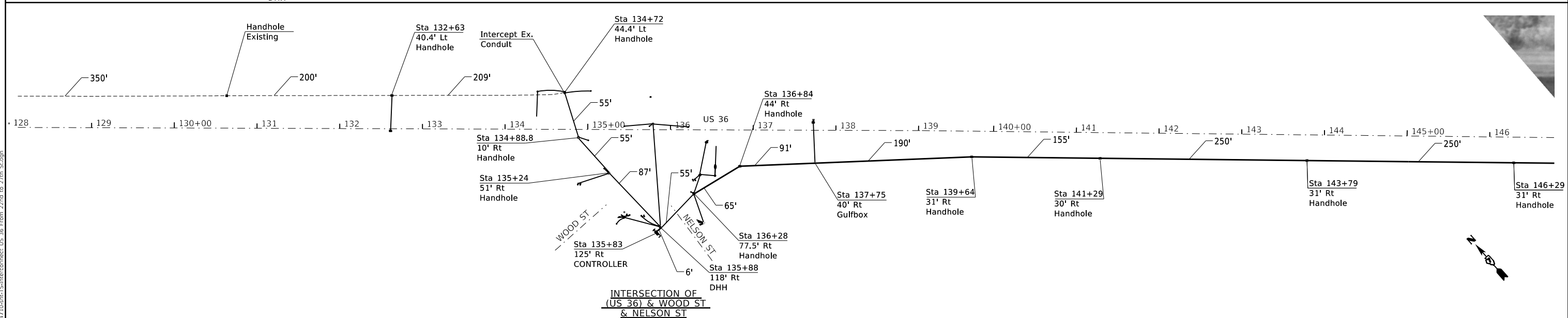
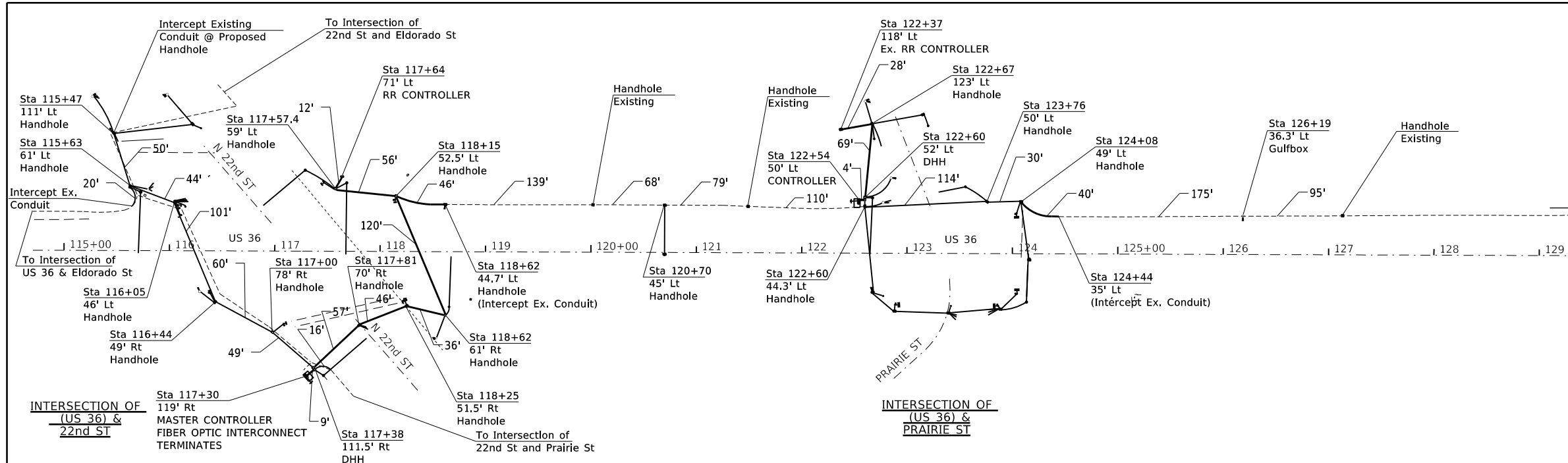

USER NAME = steffemk	DESIGNED -	REVISED -
DRAWN -	REVISED -	REVISED -
PLOT SCALE = 120,0000' / in.	CHECKED -	REVISED -
PLOT DATE = 2/21/2020	DATE -	REVISED -

**STATE OF ILLINOIS
DEPARTMENT OF TRANSPORTATION**

**US RTE 36 22nd to 27th STREET
OVERVIEW OF FIBER OPTIC INTERCONNECT**

F.A.P. RTE.	SECTION	COUNTY	TOTAL SHEETS	SHEET NO.
320	(137z, 139-X-2)RS-2	MACON	262	211
CONTRACT NO. 74710				
ILLINOIS		FED. AID PROJECT		

MODEL: Default
FILE: \\hpc1\p\pub\baronon.dwg
PROJECT: 74710\CADD\DATA\CADD\Drawings\74710\FiberOpticInterconnect_US_36_From_22nd_to_27th_St.dwg

FIBER OPTIC INTERCONNECT

The proposed Fiber Optic Interconnect will be installed from the master controller cabinet at 22nd St to each controller cabinet at the intersections shown. Locations as shown for the existing conduit and handholes along the interconnect from the Intersections of 22nd St & Eldorado, US 36 & Eldorado and 22nd St & East Prairie St. were obtained from existing plans not field measurements. Final locations and lengths will be determined in the field.

The Existing Fiber Optic Interconnect wiring 62.5/125 6F FO will be pulled and new 62.5/125 6F FO will be installed. Final locations and lengths will be determined in the field.

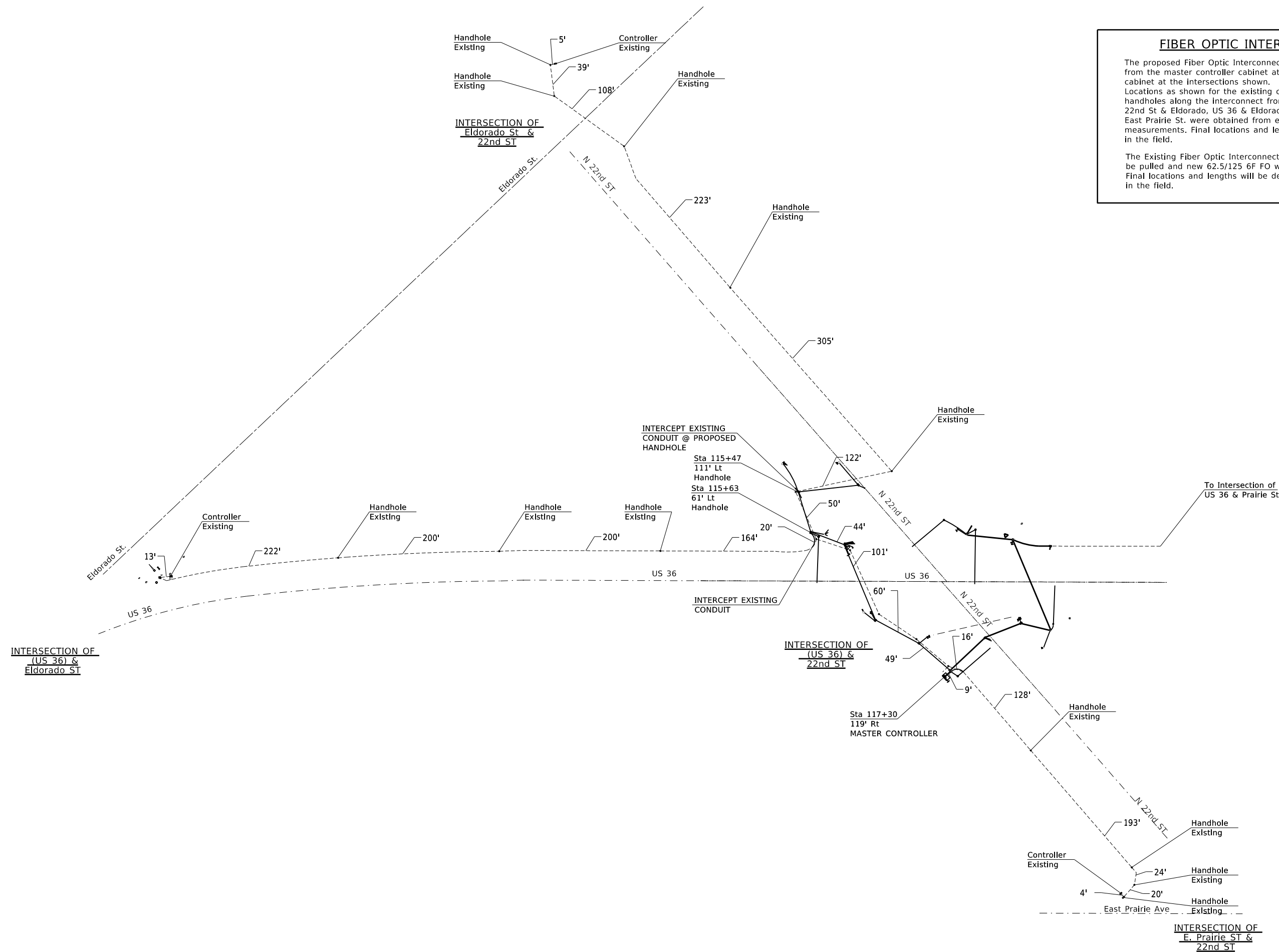

MODEL: Default
 FILE: \\blairc:\pub\blaircom\data\illinois\pwr\WIDOT\Documents\IBDOT_Offices\blair\7/Projects/74710\CADD\data\CADDsheets\IBDOT_7/Projects/74710\CADD\data\CADDsheets\IBDOT_74710\FiberOpticInterconnect_US_36_From_22nd_to_27th_Sr.dwg



USER NAME = steffemk	DESIGNED -	REVISED -
	DRAWN -	REVISED -
PLOT SCALE = 1/20,000' / in.	CHECKED -	REVISED -
PLOT DATE = 2/20/2020	DATE -	REVISED -

**STATE OF ILLINOIS
 DEPARTMENT OF TRANSPORTATION**

**US RTE 36 & Eldorado, Eldorado & 22nd St, E Prairie & 22nd St
 OVERVIEW OF FIBER OPTC INTERCONNECT**

F.A.P. RTE.	SECTION	COUNTY	TOTAL SHEETS	SHEET NO.
320	(137z, 139-X-2)RS-2	MACON	262	212
CONTRACT NO. 74710				

SCALE: SHEET OF SHEETS STA. TO STA.

ILLINOIS FED. AID PROJECT

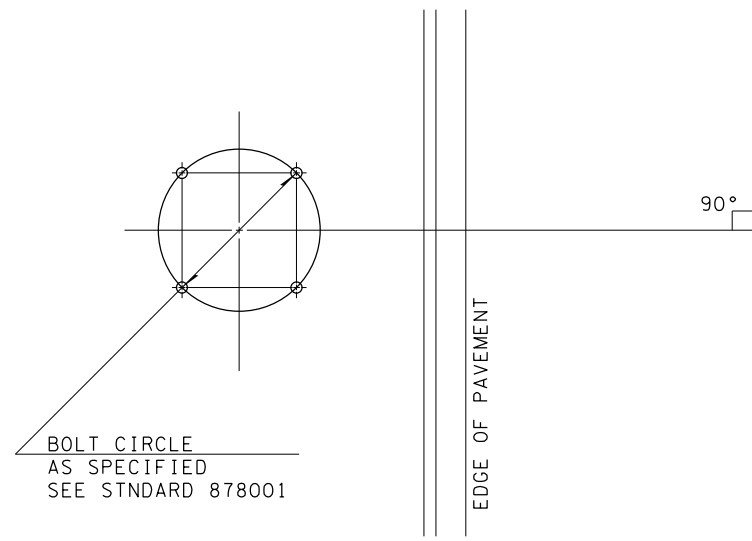

DETAIL OF MAST ARM FOUNDATION
BOLT PATTERN

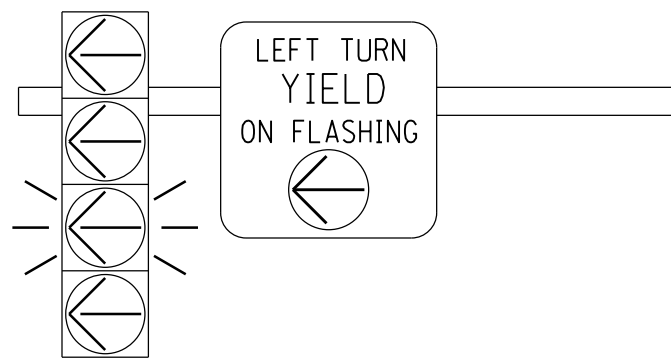

FLASHING YELLOW ARROW
SIGN PANEL DETAILS

1. SIGN SHALL HAVE A BLACK REFLECTORIZED LEGEND AND BORDER ON A WHITE REFLECTORIZED BACKGROUND. ARROW IS YELLOW ON A BLACK BACKGROUND.
2. AP SHEETING.
3. SIGN TO BE INSTALLED DIRECTLY ADJACENT TO FYA SIGNAL HEAD ON MAST ARM.
4. ILLINOIS STANDARD R10-1109a SIGN.

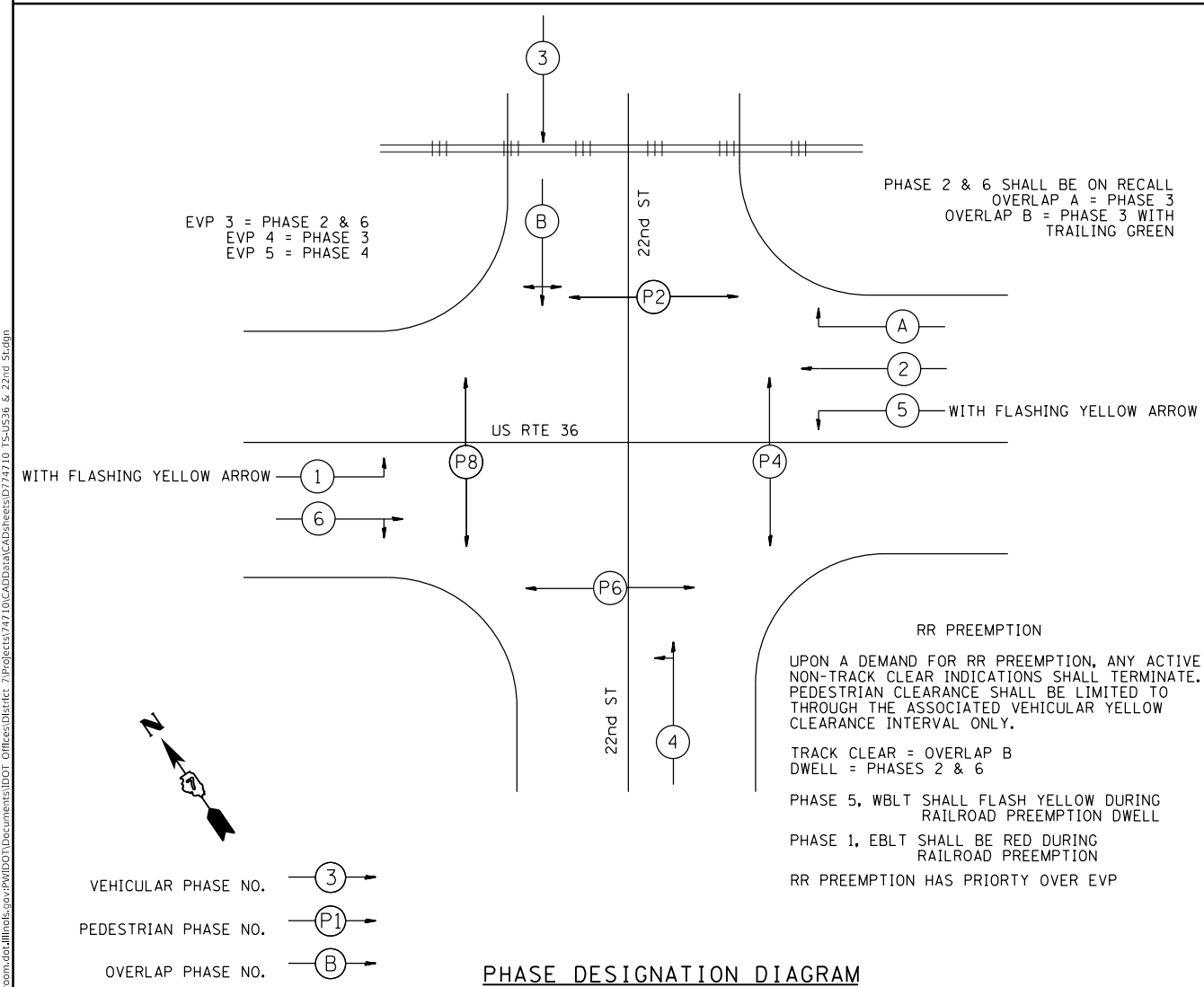
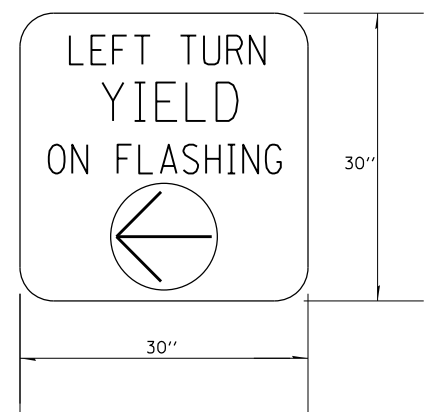

PHASE DESIGNATION DIAGRAM

1. SIGN SHALL HAVE A WHITE REFLECTORIZED LEGEND AND BORDER ON A GREEN REFLECTORIZED BACKGROUND.
2. AP SHEETING.
3. UPPER/LOWER CASE LETTERS, HIGHWAY D.

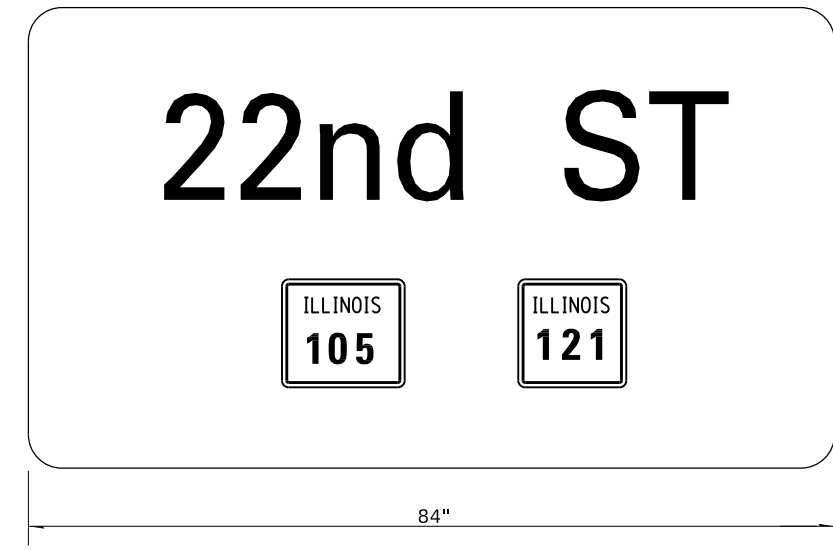

TO BE INSTALLED ON WESTBOUND MAST ARM (STA 115+54 43.3' LT)
TO BE INSTALLED ON EASTBOUND MAST ARM (STA 118+74 51.8' RT)

1. SIGN SHALL HAVE A WHITE REFLECTORIZED LEGEND AND BORDER ON A GREEN REFLECTORIZED BACKGROUND.
2. AP SHEETING.
3. UPPER/LOWER CASE LETTERS, HIGHWAY D.

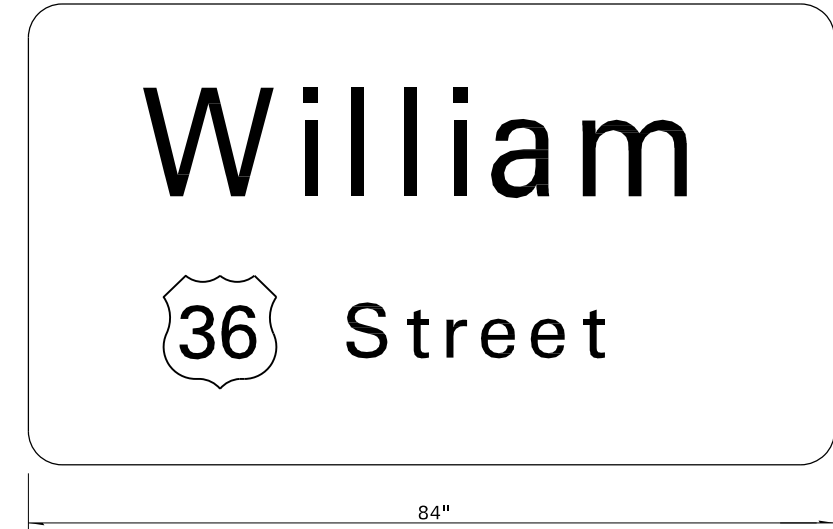

TO BE INSTALLED ON WESTBOUND MAST ARM (STA 117+68 74' LT)

SIGN PANEL DETAILS

MODEL: Default
FILE: \\nas01\pub\harcourt\ad\illinois\p\p\DOT\Documents\DOT_Offices\Illinois\7\Projects\74710\CADD\Drawings\74710_15-15256_6_22nd_St.dgn

USER NAME = steffemk	DESIGNED -	REVISED -
	DRAWN -	REVISED -
PLOT SCALE = 19.9998 ' / in.	CHECKED -	REVISED -
PLOT DATE = 2/20/2020	DATE -	REVISED -

STATE OF ILLINOIS
DEPARTMENT OF TRANSPORTATION

INTERSECTION OF US RTE 36 & 22nd ST DETAILS			
SCALE:	SHEET	OF SHEETS	STA. TO STA.

F.A.P. RTE.	SECTION	COUNTY	TOTAL SHEETS	SHEET NO.
320	(137Z, 139-X-2)RS-2	MACON	262	213
CONTRACT NO. 74710				
ILLINOIS FED. AID PROJECT				

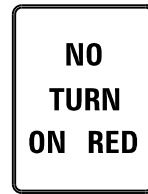

24"x30"
Black on White
MUTCD SIGN DESIGNATION R10-11

TO INSTALLED ON WB SIGNAL POST (STA 118+14 49.2' LT)
TO INSTALLED ON SB SIGNAL POST (STA 115+43 116' LT)



24"x30"
Black on White
MUTCD SIGN DESIGNATION R8-8

TO INSTALLED ON SB SIGNAL POST (STA 116+07.8 43.2' LT)
TO INSTALLED ON EXISTING SIGN POST IN MEDIAN (STA 116+74 64.6' LT)

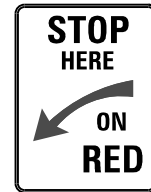

24"x30"
Black on White
MUTCD SIGN DESIGNATION R10-6A

TO INSTALLED ON SB SIGNAL POST (STA 115+43 116' LT)

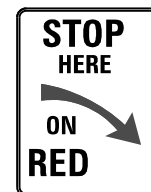

24"x30"
Black on White
MUTCD SIGN DESIGNATION R10-6A

TO INSTALLED ON SB POST IN MEDIAN (STA 115+97 155' LT)

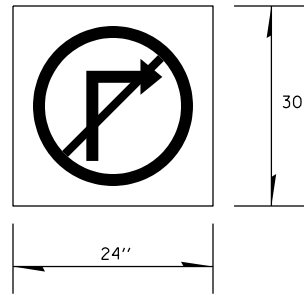

ILLUMINATED SIGN, LED

LED BLANK OUT, RAILROAD PRE-EMPTIVE ACTIVATION

TO BE INSTALLED ON MAST SIGNAL POST (STA 117+29 77' LT)
TO BE INSTALLED ON TRAFFIC SIGNAL HEAD POST (STA 118+14 49.2' LT)



36"x15"
Black on White

36"x36"

Black on White
MUTCD SIGN DESIGNATION MI-4

TO BE INSTALLED ON WESTBOUND MAST ARM (STA 115+72.5 55.7' RT)

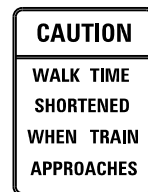

18"x24"
Black on White
ILLINOIS SUPPLEMENT TO THE
MUTCD SIGN DESIGNATION W10-1101

- (2) TO BE INSTALLED ON PED & TRAFFIC SIGNAL HEAD POST (STA 116+07.8 43.2' LT)
- (1) TO BE INSTALLED ON PED & TRAFFIC SIGNAL HEAD POST (STA 116+39 40.3' RT)
- (1) TO BE INSTALLED ON PED SIGNAL HEAD POST (STA 117+08.6 69' RT)
- (1) TO BE INSTALLED ON PED SIGNAL HEAD POST (STA 117+46.4 65.1' RT)
- (1) TO BE INSTALLED ON PED & TRAFFIC SIGNAL HEAD POST (STA 118+14 49.2' LT)
- (2) TO BE INSTALLED ON PED & TRAFFIC SIGNAL HEAD POST (STA 118+23.8 47' LT)

SIGN PANEL DETAILS

MODEL: Default
 FILE: \\blake.pw.us.ibm.com\data\illinois\pwr\DOT\Documents\DOT_Offices\Illinet\7\Projects\74710\CAAD\Drawings\Drawings\74710_15-0526_6_22nd_St.dgn

USER NAME = steffenmk	DESIGNED -
PLOT SCALE = 19.9998 ' / in.	CHECKED -
PLOT DATE = 2/20/2020	DATE -

REVISED -
REVISED -
REVISED -
REVISED -

**STATE OF ILLINOIS
DEPARTMENT OF TRANSPORTATION**

**INTERSECTION OF US RTE 36 & 22nd ST
SIGN PANNEL DETAILS**

SCALE: SHEET OF SHEETS STA. TO STA.

F.A.P. RTE.	SECTION	COUNTY	TOTAL SHEETS	SHEET NO.
320	(137Z, 139-X-2)RS-2	MACON	262	214
CONTRACT NO. 74710				
ILLINOIS FED. AID PROJECT				

US RTE 36 22ND STREET ST-BILL OF MATERIALS

ITEM	UNIT	QUANTITY
SIGN PANEL-TYPE 1	SQ FT	86
SIGN PANEL-TYPE 3	SQ FT	84
SERVICE INSTALLATION, TYPE A	EACH	1
UNDERGROUND CONDUIT, PVC 3/4" DIA.	FOOT	167
UNDERGROUND CONDUIT, PVC 1 1/2" DIA.	FOOT	260
UNDERGROUND CONDUIT, PVC 2" DIA.	FOOT	95
UNDERGROUND CONDUIT, PVC 4" DIA.	FOOT	457
UNDERGROUND CONDUIT, PVC 5" DIA.	FOOT	266
HANDHOLE	EACH	12
DOUBLE HANDHOLE	EACH	1
GULFBOX JUNCTION	EACH	4
MAINTENANCE OF EXISTING TRAFFIC SIGNAL INSTALLATION	EACH	1
RAILROAD FULL-ACTUATED CONTROLLER AND TYPE V CABINET	EACH	1
MASTER CONTROLLER	EACH	1
UNINTERRUPTABLE POWER SUPPLY, EXTENDED	EACH	1
TRANSCEIVER-FIBER OPTIC	EACH	1
ELECTRIC CABLE IN CONDUIT, SIGNAL NO 14 3C	FOOT	2740
ELECTRIC CABLE IN CONDUIT, SIGNAL NO 14 5C	FOOT	5350
ELECTRIC CABLE IN CONDUIT, SIGNAL NO 14 7C	FOOT	2582
ELECTRIC CABLE IN CONDUIT, LEAD-IN NO 14 1 PAIR	FOOT	3785
ELECTRIC CABLE IN CONDUIT, RAILROAD, NO 14 3C	FOOT	399
ELECTRIC CABLE IN CONDUIT, SERVICE, NO 6 2C	FOOT	16
ELECTRIC CABLE IN CONDUIT, EQUIPMENT GROUNDING CONDUCTOR, NO 6 1C	FOOT	1015
TRAFFIC SIGNAL POST, GALVANIZED STEEL 8 FT	EACH	1
TRAFFIC SIGNAL POST, GALVANIZED STEEL 12 FT	EACH	2
TRAFFIC SIGNAL POST, GALVANIZED STEEL 14 FT	EACH	1
TRAFFIC SIGNAL POST, GALVANIZED STEEL 16 FT	EACH	2
TRAFFIC SIGNAL POST, GALVANIZED STEEL 18 FT	EACH	2
PEDESTRIAN PUSH BUTTON POST	EACH	2
STEEL MAST ARM ASSEMBLY AND POLE, 48 FT	EACH	1
STEEL MAST ARM ASSEMBLY AND POLE, 52 FT	EACH	1
STEEL MAST ARM ASSEMBLY AND POLE, 54 FT	EACH	1
STEEL MAST ARM ASSEMBLY AND POLE, 58 FT	EACH	1
STEEL MAST ARM ASSEMBLY AND POLE, 68 FT	EACH	1
CONCRETE FOUNDATION, TYPE A	FOOT	24
CONCRETE FOUNDATION, TYPE C	FOOT	3.5
CONCRETE FOUNDATION, TYPE E 36-INCH DIAMETER	FOOT	15
CONCRETE FOUNDATION, TYPE E 42-INCH DIAMETER	FOOT	88
DRILL EXISTING HANDHOLE	EACH	1
SIGNAL HEAD, POLYCARBONATE, LED, 1-FACE, 3-SECTION, BRACKET MOUNTED	EACH	3
SIGNAL HEAD, POLYCARBONATE, LED, 1-FACE, 3-SECTION, MAST ARM MOUNTED	EACH	15
SIGNAL HEAD, POLYCARBONATE, LED, 1-FACE, 4-SECTION, MAST ARM MOUNTED	EACH	3
SIGNAL HEAD, POLYCARBONATE, LED, 1-FACE, 5-SECTION, MAST ARM MOUNTED	EACH	1
SIGNAL HEAD, POLYCARBONATE, LED, 2-FACE, 3-SECTION, BRACKET MOUNTED	EACH	1
SIGNAL HEAD, POLYCARBONATE, LED, 2-FACE, 1-3-SECTION, 1-4-SECTION, BRACKET MOUNTED	EACH	1
SIGNAL HEAD, POLYCARBONATE, LED, 2-FACE, 1-4-SECTION, 1-5-SECTION, BRACKET MOUNTED	EACH	1
PEDESTRIAN SIGNAL HEAD, POLYCARBONATE, LED, 1-FACE, BRACKET MOUNTED	EACH	4
PEDESTRIAN SIGNAL HEAD, POLYCARBONATE, LED, 2-FACE, BRACKET MOUNTED	EACH	2
TRAFFIC SIGNAL BACKPLATE, LOUVERED, FORMED PLASTIC	EACH	28

US RTE 36 22ND STREET ST-BILL OF MATERIALS

ITEM	UNIT	QUANTITY
INDUCTIVE LOOP DETECTOR	EACH	14
DETECTOR LOOP, TYPE 1	FOOT	1828
PEDESTRIAN PUSH-BUTTON	EACH	8
TEMPORARY TRAFFIC SIGNAL INSTALLATION	EACH	1
REMOVE EXISTING SERVICE INSTALLATION	EACH	1
REMOVE EXISTING TRAFFIC SIGNAL EQUIPMENT	EACH	1
REMOVE EXISTING HANDHOLE	EACH	10
REMOVE EXISTING CONCRETE FOUNDATION	EACH	11
SPARE FULL ACTUATED CONTROLLER, SPECIAL	EACH	1
ILLUMINATED SIGN, SPECIAL	EACH	2
EMERGENCY VEHICLE PRIORITY SYSTEM	EACH	1

The below BILL OF MATERIALS is for the quantities along US 36 from 22nd St to 27th St. along with the existing Fiber Optic Interconnect that will be removed and replaced from the intersections of Eldorado St. & 22nd, US 36 & Eldorado St., and E. Prairie & 22nd St. The Proposed Fiber Optic Interconnect will extend from 22nd St to 27th St for continuity of the traffic signal system. A proposed Master Controller and a Full Actuated Controller shall replace the existing controller at US 36 & 22nd St. The existing controller has 3 Fiber Optic Interconnect Cables terminating. The proposed master controller will have 4 Fiber Optic Interconnect Cables terminating. Connecting a total of 7 intersections.

US RTE 36 INTERCONNECT-TOTAL BILL OF MATERIALS

ITEM	UNIT	QUANTITY
HANDHOLE	EACH	9
FIBER OPTIC CABLE IN CONDUIT, NO 62.5/125, 6F	FOOT	7592
REMOVE ELECTRIC CABLE FROM CONDUIT	FOOT	3647

MODEL: Default
 FILE: \\nas01c.paulson.com\data\illinois\pwr\DOT\Documents\DOT_Offices\Illinois\7\Projects\71710\CAD\data\CAD\sheet\71710_15-51536_6_22nd_St.dgn

USER NAME = steffenmk	DESIGNED -	REVISED -
PLOT SCALE = 39.9996 ' / in.	DRAWN -	REVISED -
PLOT DATE = 2/20/2020	CHECKED -	REVISED -
	DATE -	REVISED -

**STATE OF ILLINOIS
DEPARTMENT OF TRANSPORTATION**

**INTERSECTION OF US RTE 36 & 22nd ST
BILL OF MATERIALS**

SCALE: SHEET OF SHEETS STA. TO STA.

*F.A.P. 323 & F.A.U. 7404

F.A.P. RTE.	SECTION	COUNTY	TOTAL SHEETS	SHEET NO.
320	(137Z, 139-X-2)RS-2	MACON	262	215
CONTRACT NO. 74710				
		ILLINOIS	FED. AID PROJECT	

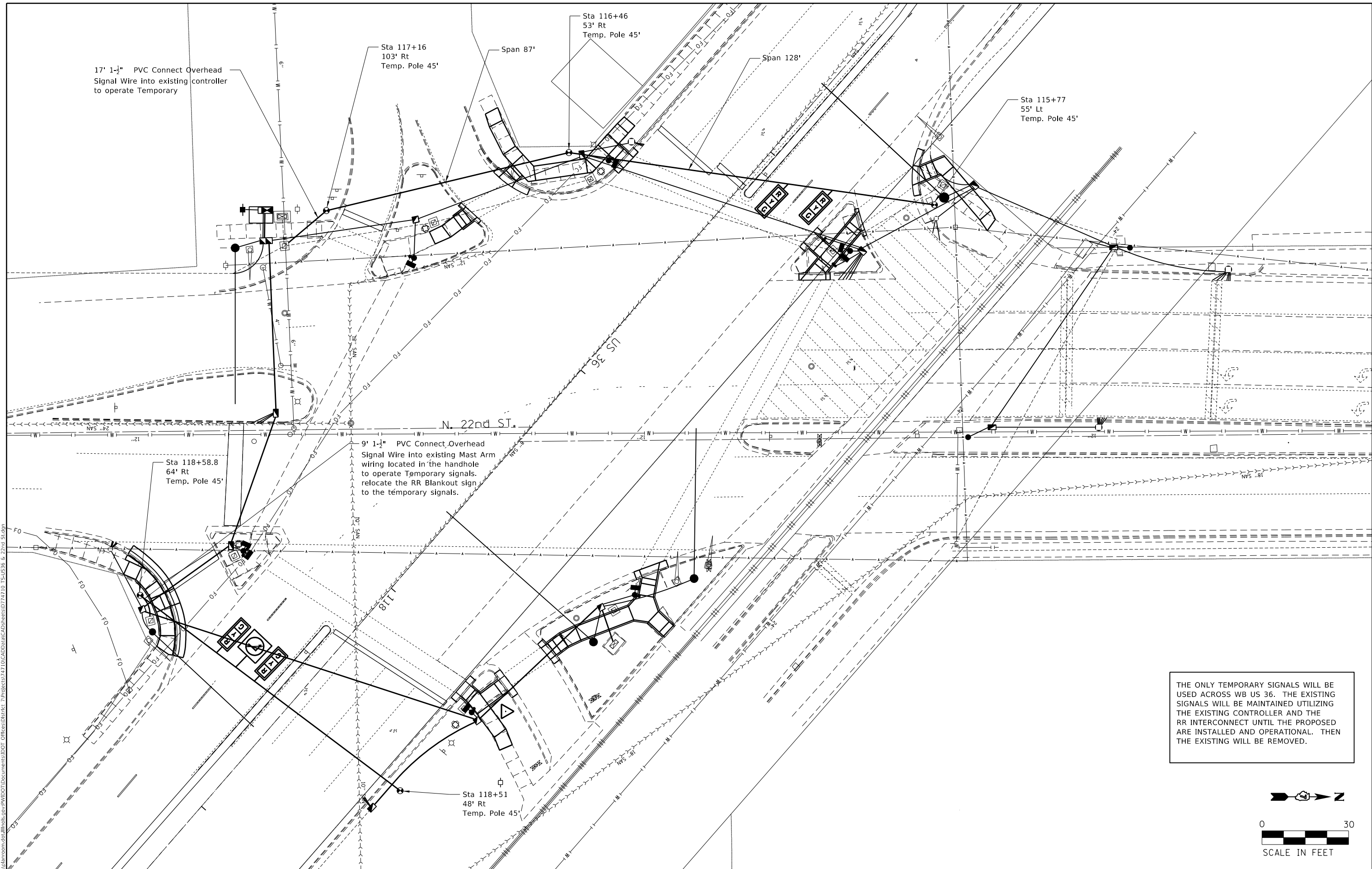

17' 1-1/2" PVC Connect Overhead Signal Wire into existing controller to operate Temporary

9' 1-1/2" PVC Connect Overhead Signal Wire into existing Mast Arm wiring located in the handhole to operate Temporary signals. relocate the RR Blankout sign to the temporary signals.

THE ONLY TEMPORARY SIGNALS WILL BE USED ACROSS WB US 36. THE EXISTING SIGNALS WILL BE MAINTAINED UTILIZING THE EXISTING CONTROLLER AND THE RR INTERCONNECT UNTIL THE PROPOSED ARE INSTALLED AND OPERATIONAL. THEN THE EXISTING WILL BE REMOVED.

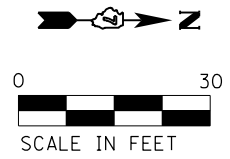

MODEL: Default
 FILE: h:\m\c\p\subarooms\dat\illinois\poc\p\w\dot\Documents\DOT_Offices\Illin\7\Projects\74710\CADD\data\CAD\sheet\74710_T54\526 & 22nd St.dgn

USER NAME = steffemk	DESIGNED -	REVISED -
	DRAWN -	REVISED -
PLOT SCALE = 30.0000' / in.	CHECKED -	REVISED -
PLOT DATE = 2/20/2020	DATE -	REVISED -

STATE OF ILLINOIS
DEPARTMENT OF TRANSPORTATION

INTERSECTION OF US RTE 36 & 22nd ST				
TEMPORARY SIGNAL LAYOUT				
SCALE:	SHEET	OF	SHEETS	STA. TO STA.

F.A.P. RTE.	SECTION	COUNTY	TOTAL SHEETS	SHEET NO.
320	(137Z, 139-X-2)RS-2	MACON	262	216
CONTRACT NO. 74710				
ILLINOIS FED. AID PROJECT				

MODEL: Default
 FILE: \\barcoms.dia.illinois.gov\PI\DOT\Documents\DOT_Offices\District 7\Projects\74710\CAD\Drawings\DOT_74710_154536 & 22nd_St.dgn

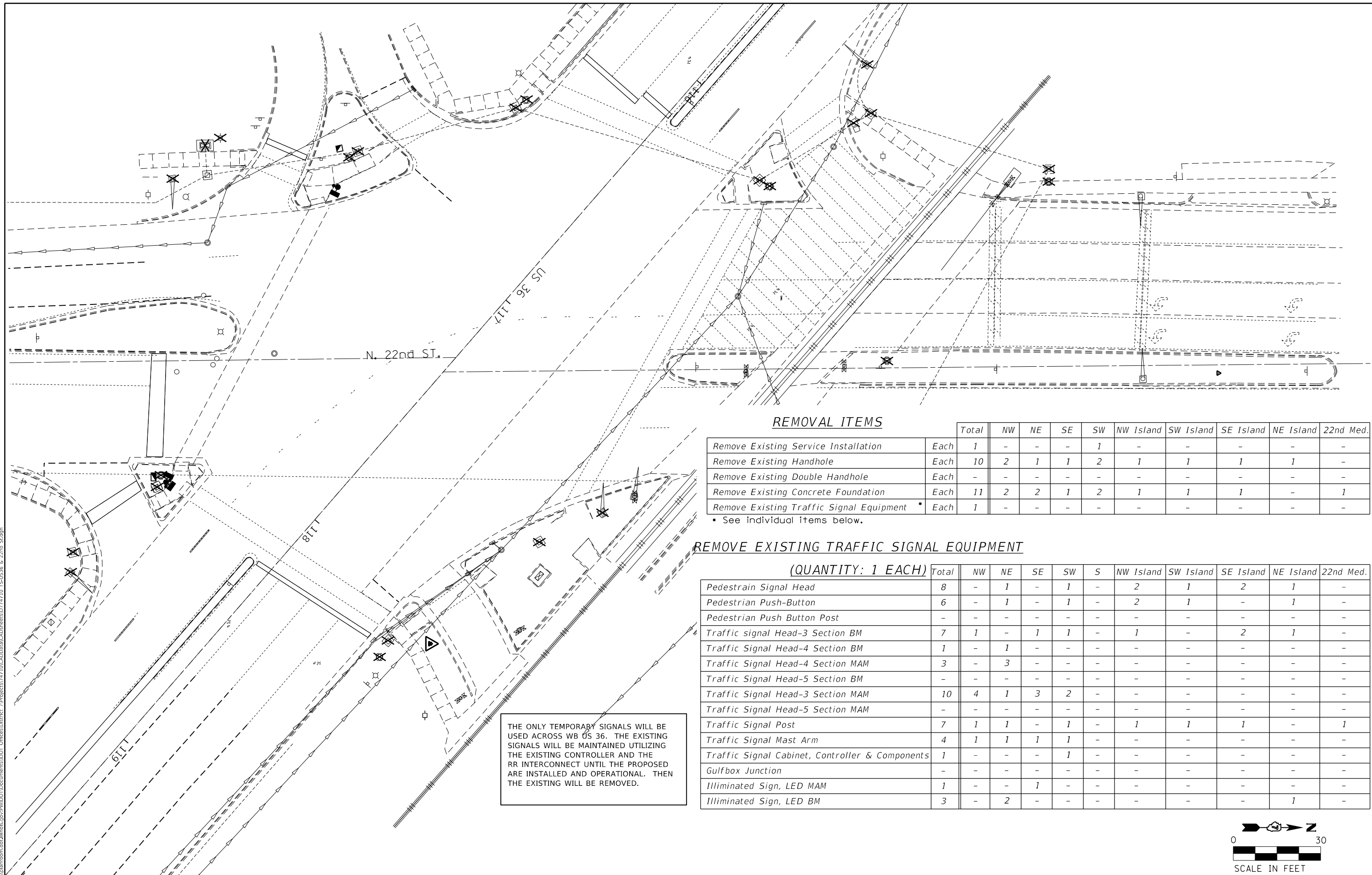

THE ONLY TEMPORARY SIGNALS WILL BE USED ACROSS WB US 36. THE EXISTING SIGNALS WILL BE MAINTAINED UTILIZING THE EXISTING CONTROLLER AND THE RR INTERCONNECT UNTIL THE PROPOSED ARE INSTALLED AND OPERATIONAL. THEN THE EXISTING WILL BE REMOVED.

REMOVAL ITEMS

	Total	NW	NE	SE	SW	NW Island	SW Island	SE Island	NE Island	22nd Med.
Remove Existing Service Installation	Each 1	-	-	-	1	-	-	-	-	-
Remove Existing Handhole	Each 10	2	1	1	2	1	1	1	1	-
Remove Existing Double Handhole	Each -	-	-	-	-	-	-	-	-	-
Remove Existing Concrete Foundation	Each 11	2	2	1	2	1	1	1	-	1
Remove Existing Traffic Signal Equipment	Each 1	-	-	-	-	-	-	-	-	-

• See individual items below.

REMOVE EXISTING TRAFFIC SIGNAL EQUIPMENT

(QUANTITY: 1 EACH)

	Total	NW	NE	SE	SW	S	NW Island	SW Island	SE Island	NE Island	22nd Med.
Pedestrian Signal Head	8	-	1	-	1	-	2	1	2	1	-
Pedestrian Push-Button	6	-	1	-	1	-	2	1	-	1	-
Pedestrian Push Button Post	-	-	-	-	-	-	-	-	-	-	-
Traffic signal Head-3 Section BM	7	1	-	1	1	-	1	-	2	1	-
Traffic Signal Head-4 Section BM	1	-	1	-	-	-	-	-	-	-	-
Traffic Signal Head-4 Section MAM	3	-	3	-	-	-	-	-	-	-	-
Traffic Signal Head-5 Section BM	-	-	-	-	-	-	-	-	-	-	-
Traffic Signal Head-3 Section MAM	10	4	1	3	2	-	-	-	-	-	-
Traffic Signal Head-5 Section MAM	-	-	-	-	-	-	-	-	-	-	-
Traffic Signal Post	7	1	1	-	1	-	1	1	1	-	1
Traffic Signal Mast Arm	4	1	1	1	1	-	-	-	-	-	-
Traffic Signal Cabinet, Controller & Components	1	-	-	-	1	-	-	-	-	-	-
Gulfbox Junction	-	-	-	-	-	-	-	-	-	-	-
Illuminated Sign, LED MAM	1	-	-	1	-	-	-	-	-	-	-
Illuminated Sign, LED BM	3	-	2	-	-	-	-	-	-	1	-

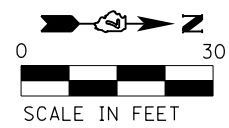

USER NAME = steffenmk	DESIGNED -	REVISED -
	DRAWN -	REVISED -
PLOT SCALE = 30.0000 "/td> <td>CHECKED -</td> <td>REVISED -</td>	CHECKED -	REVISED -
PLOT DATE = 2/20/2020	DATE -	REVISED -

STATE OF ILLINOIS
DEPARTMENT OF TRANSPORTATION

INTERSECTION OF US RTE 36 & 22nd ST
REMOVAL ITEMS

SCALE: SHEET OF SHEETS STA. TO STA.

F.A.P. RTE.	SECTION	COUNTY	TOTAL SHEETS	SHEET NO.
320	(137Z, 139-X-2)RS-2	MACON	262	217
CONTRACT NO. 74710				
ILLINOIS FED. AID PROJECT				

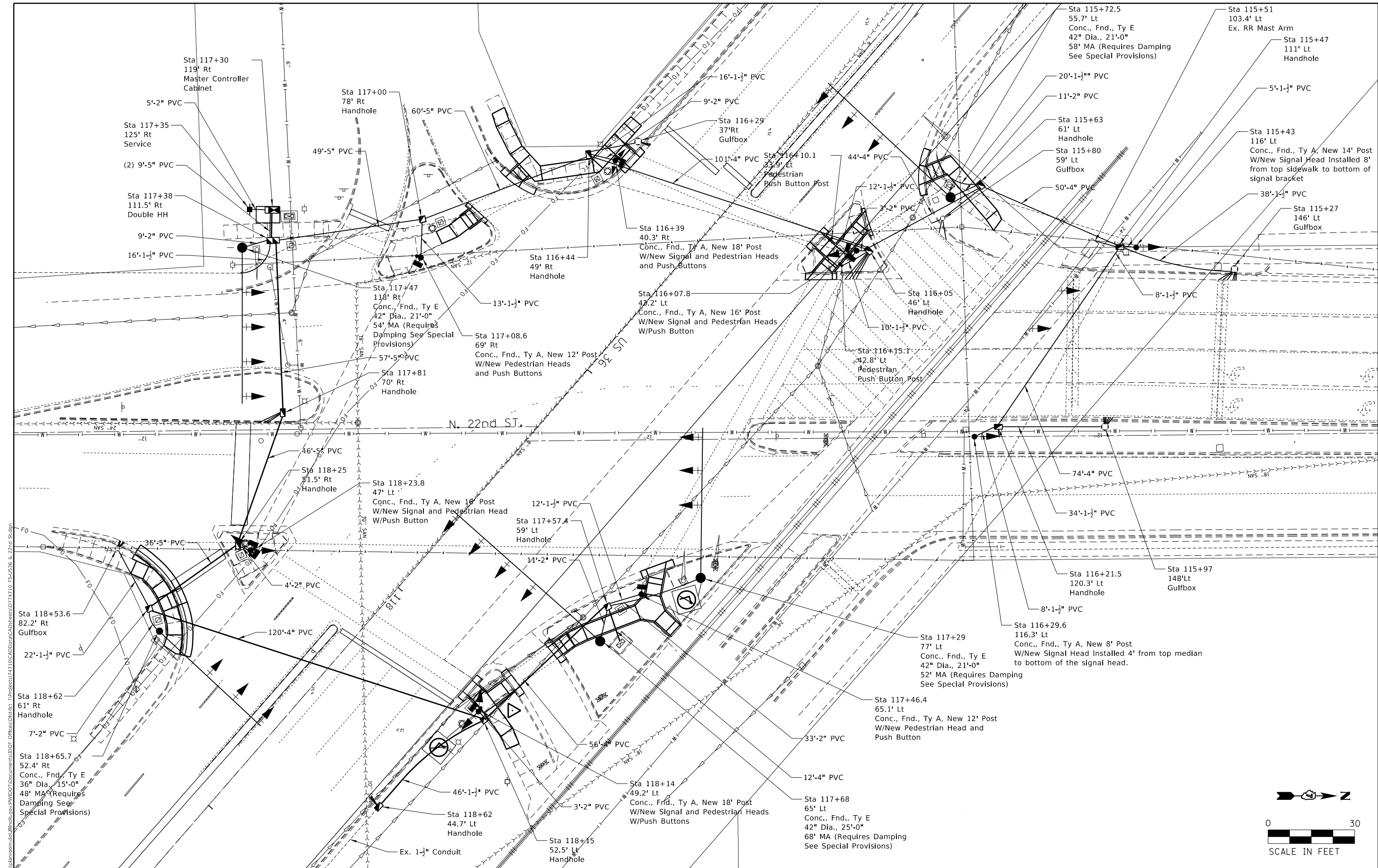

MODEL: Default
 FILE: \\s:\pub\barcom\dat\illinois\p\p\WIDOT\Documents\DOT Office\Drawings\74710\CADD\Drawings\74710 TS-54526 & 22nd St.dgn

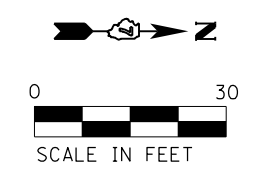

USER NAME = stefenmk	DESIGNED -	REVISED -
DRAWN -	REVISED -	REVISED -
PLOT SCALE = 30.0000' / in.	CHECKED -	REVISED -
PLOT DATE = 2/20/2020	DATE -	REVISED -

**STATE OF ILLINOIS
DEPARTMENT OF TRANSPORTATION**

**INTERSECTION OF US RTE 36 & 22nd ST
SIGNAL LAYOUT**

SCALE: SHEET OF SHEETS STA. TO STA.

F.A.P. RTE.	SECTION	COUNTY	TOTAL SHEETS	SHEET NO.
320	(137Z, 139-X-2)RS-2	MACON	262	218
CONTRACT NO. 74710				
ILLINOIS		FED. AID PROJECT		

MODEL: Default
 FILE: \\nas01c.psu.edu\pub\barcom\ada\illinois\gov\PIWDOT\Documents\DOT_Offices\Illinet\7\Projects\74710\CADD\DATA\CAD\Sheet\74710_154536_6_22nd_St.dgn

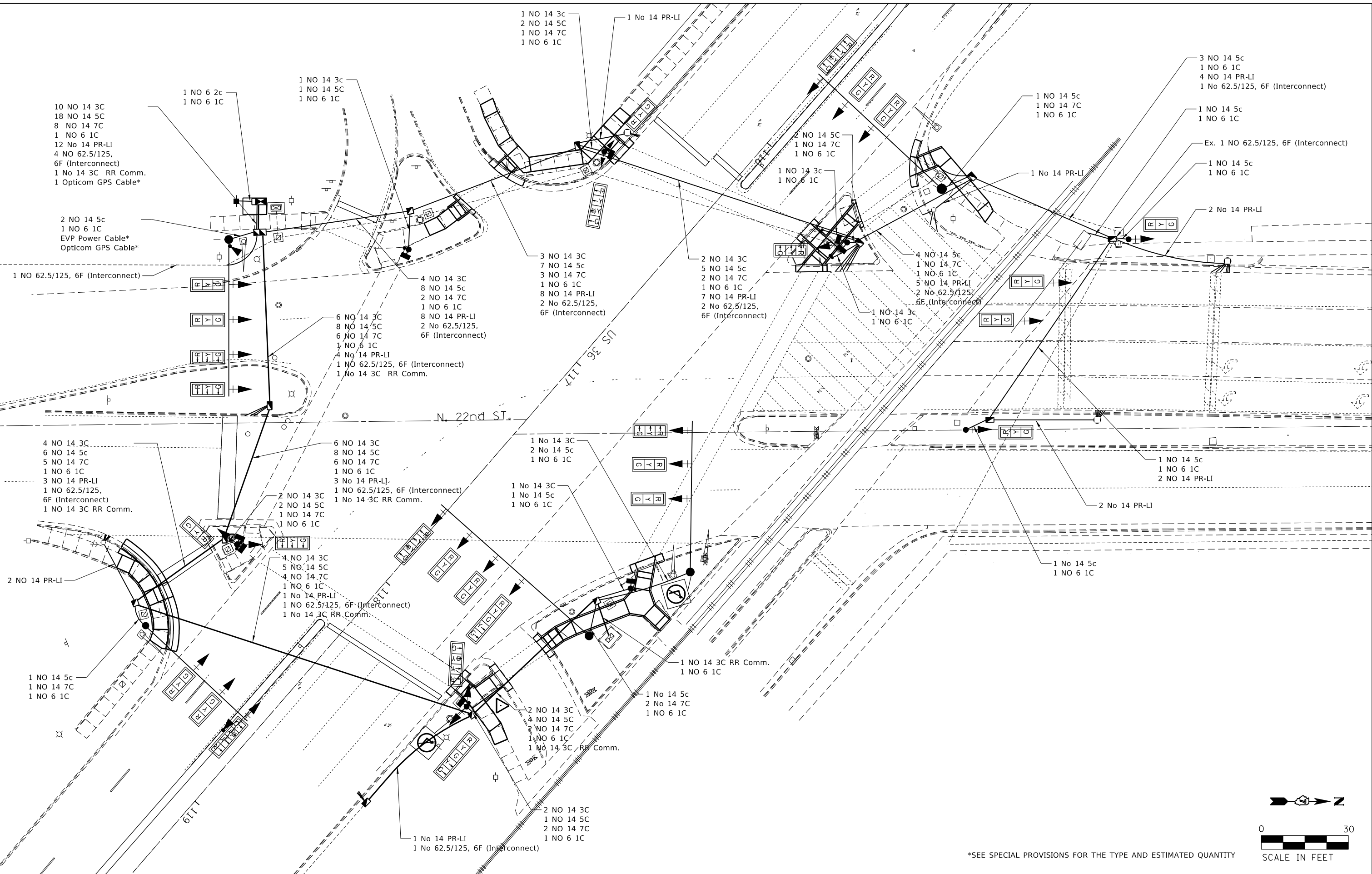

*SEE SPECIAL PROVISIONS FOR THE TYPE AND ESTIMATED QUANTITY

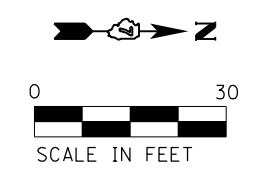

USER NAME = steffemk	DESIGNED -	REVISED -
	DRAWN -	REVISED -
PLOT SCALE = 30.0000' / in.	CHECKED -	REVISED -
PLOT DATE = 2/20/2020	DATE -	REVISED -

STATE OF ILLINOIS
DEPARTMENT OF TRANSPORTATION

INTERSECTION OF US RTE 36 & 22nd ST				
CABLE LAYOUT				
SCALE:	SHEET	OF	SHEETS	STA. TO STA.

F.A.P. RTE.	SECTION	COUNTY	TOTAL SHEETS	SHEET NO.
320	(137Z, 139-X-2)RS-2	MACON	262	219
CONTRACT NO. 74710				
ILLINOIS FED. AID PROJECT				

MODEL: Default
 FILE: \\nas01c.pva\pub\barcom\ada\illink\poc\PI\DOT\Documents\DOT_Offices\Illinet\7\Projects\71710\CADD\DATA\CAD\Sheet\71710_15-1526 & 22nd_Std.dgn

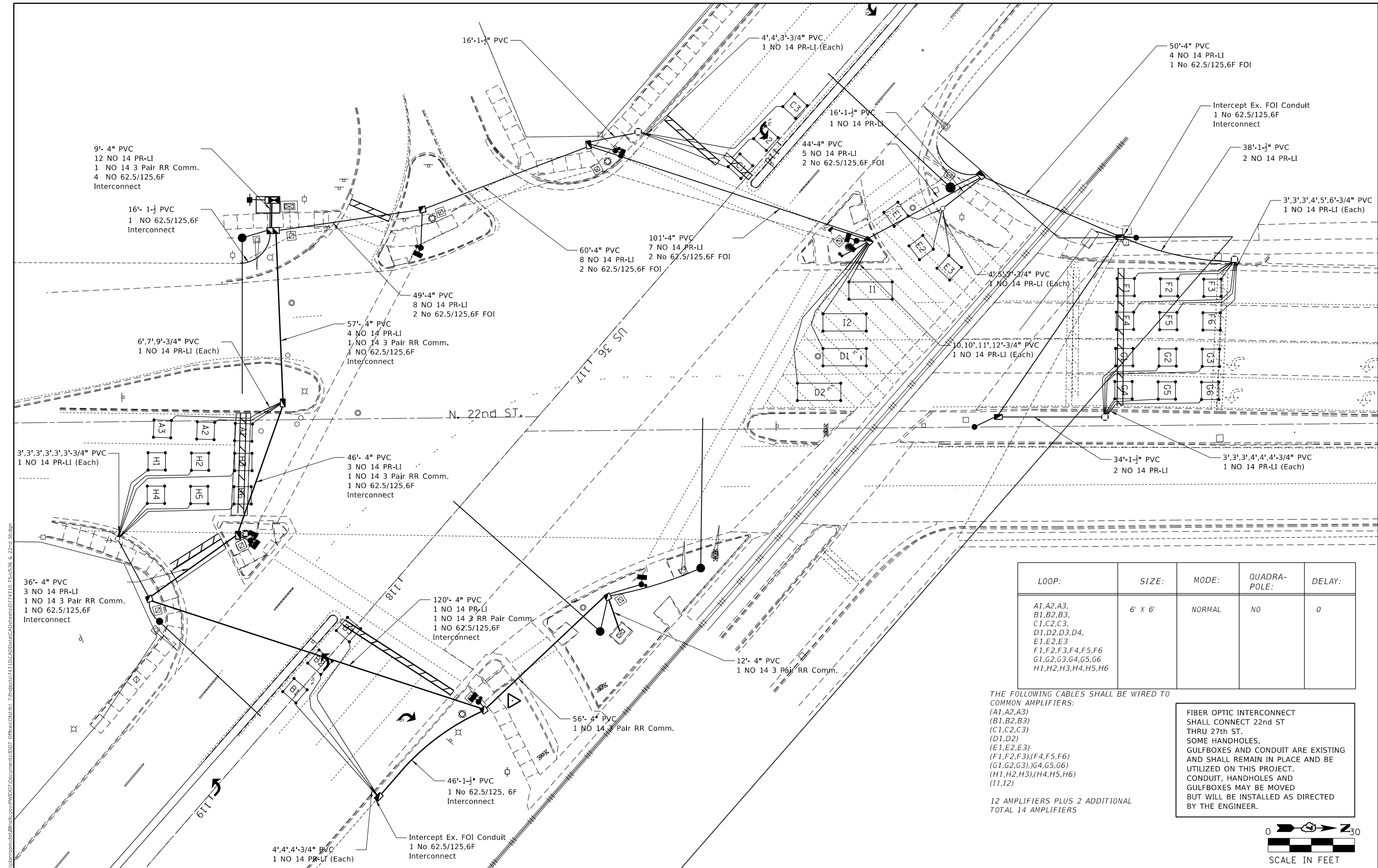

LOOP:	SIZE:	MODE:	QUADRA-POLE:	DELAY:
A1,A2,A3, B1,B2,B3, C1,C2,C3, D1,D2,D3,D4, E1,E2,E3 F1,F2,F3,F4,F5,F6 G1,G2,G3,G4,G5,G6 H1,H2,H3,H4,H5,H6	6' X 6'	NORMAL	NO	0

THE FOLLOWING CABLES SHALL BE WIRED TO COMMON AMPLIFIERS:
 (A1,A2,A3)
 (B1,B2,B3)
 (C1,C2,C3)
 (D1,D2)
 (E1,E2,E3)
 (F1,F2,F3),(F4,F5,F6)
 (G1,G2,G3),(G4,G5,G6)
 (H1,H2,H3),(H4,H5,H6)
 (I1,I2)
 12 AMPLIFIERS PLUS 2 ADDITIONAL
 TOTAL 14 AMPLIFIERS

FIBER OPTIC INTERCONNECT SHALL CONNECT 22nd ST THRU 27th ST. SOME HANDHOLES, GULFBXES AND CONDUIT ARE EXISTING AND SHALL REMAIN IN PLACE AND BE UTILIZED ON THIS PROJECT. CONDUIT, HANDHOLES AND GULFBXES MAY BE MOVED BUT WILL BE INSTALLED AS DIRECTED BY THE ENGINEER.



USER NAME = steffemk	DESIGNED -	REVISIONS -
DRAWN -	CHECKED -	REVISIONS -
PLOT SCALE = 30.0000' / in.	DATE -	REVISIONS -
PLOT DATE = 2/20/2020		

**STATE OF ILLINOIS
 DEPARTMENT OF TRANSPORTATION**

**INTERSECTION OF US RTE 36 & 22nd ST
 DETECTOR LOOPS**

SCALE: SHEET OF SHEETS STA. TO STA.

F.A.P. RTE.	SECTION	COUNTY	TOTAL SHEETS	SHEET NO.
320	(137Z, 139-X-2)RS-2	MACON	262	220
CONTRACT NO. 74710				
ILLINOIS FED. AID PROJECT				

SHEET LEFT BLANK FOR INSERTION OF THE BORING LOGS

MODEL: Default
 FILE: \\blm1c2.pw.usgblm.com\data\illinois.gov\RWIDOT\Documents\DOT_Offices\District_7\Projects\74710\CAAD\BoringCAD\BoringCAD.dwg
 7/20/2020 10:54:56 AM 2/20/2020

USER NAME = steffenmk	DESIGNED -	REVISED -
	DRAWN -	REVISED -
PLOT SCALE = 19.9998 ' / in.	CHECKED -	REVISED -
PLOT DATE = 2/20/2020	DATE -	REVISED -

**STATE OF ILLINOIS
 DEPARTMENT OF TRANSPORTATION**

**INTERSECTIONS OF US 36
 BORING LOGS**

SCALE: SHEET OF SHEETS STA. TO STA.

F.A.P. RTE.	SECTION	COUNTY	TOTAL SHEETS	SHEET NO.
320	(137Z, 139-X-2)RS-2	MACON	262	221
				CONTRACT NO. 74710
		ILLINOIS	FED. AID PROJECT	

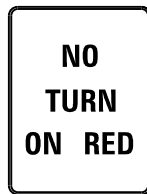

24"x30"
Black on White
MUTCD SIGN DESIGNATION R10-11

TO INSTALLED ON SB SIGNAL POST (STA 122+68' 109' LT)



24"x30"
Black on White
MUTCD SIGN DESIGNATION R8-8

TO INSTALLED ON MAST POST (STA 122+67 52.5' LT)

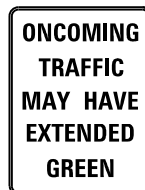

24"x30"
Black on Yellow
MUTCD SIGN DESIGNATION W25-2

TO INSTALLED ON MA (STA 123+55, 64' RT)
TO INSTALLED ON SIGNAL POST (STA 122+67, 52.5'LT)

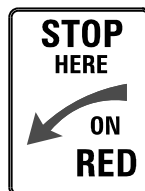

24"x30"
Black on White
MUTCD SIGN DESIGNATION R10-6A

TO INSTALLED ON SB SIGNAL POST (STA 122+68' 109' LT)

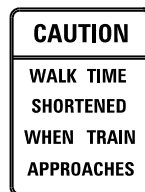

18"x24"
Black on White
ILLINOIS SUPPLEMENT TO THE
MUTCD SIGN DESIGNATION W10-1101

TO INSTALLED ON PED AND TRAFFIC SIGNAL POST (STA 122+88 49' RT)
TO INSTALLED ON PED AND TRAFFIC SIGNAL POST (STA 123+87 49.6' RT)
TO INSTALLED ON PED AND TRAFFIC SIGNAL POST (STA 124+04 39' LT)
TO INSTALLED ON PED SIGNAL POST (STA 124+04 38' RT)

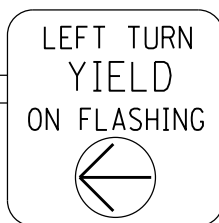
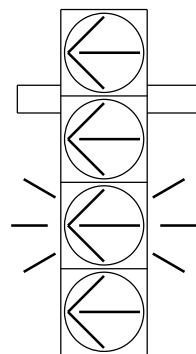

1. SIGN SHALL HAVE A BLACK REFLECTORIZED LEGEND AND BORDER ON A WHITE REFLECTORIZED BACKGROUND. ARROW IS YELLOW ON A BLACK BACKGROUND.
2. AP SHEETING.
3. SIGN TO BE INSTALLED DIRECTLY ADJACENT TO FYA SIGNAL HEAD ON MAST ARM.
4. ILLINOIS STANDARD R10-1109a SIGN.

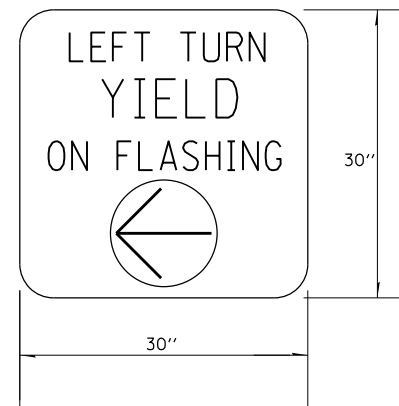

FLASHING YELLOW ARROW SIGN PANEL DETAILS

1. SIGN SHALL HAVE A WHITE REFLECTORIZED LEGEND AND BORDER ON A GREEN REFLECTORIZED BACKGROUND.
2. AP SHEETING.
3. UPPER/LOWER CASE LETTERS, HIGHWAY D.

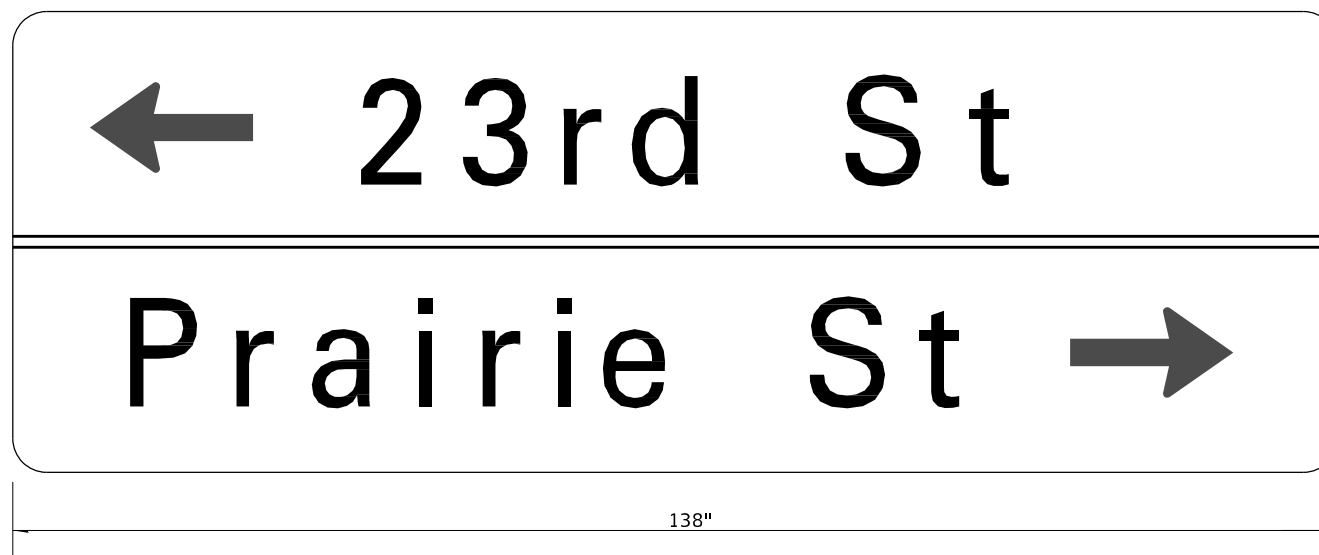

TO BE INSTALLED ON EASTBOUND MAST ARM (STA 124+14 46' RT)

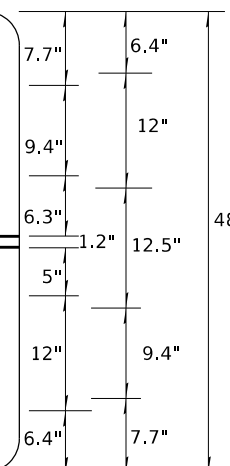

1. SIGN SHALL HAVE A WHITE REFLECTORIZED LEGEND AND BORDER ON A GREEN REFLECTORIZED BACKGROUND.
2. AP SHEETING.
3. UPPER/LOWER CASE LETTERS, HIGHWAY D.

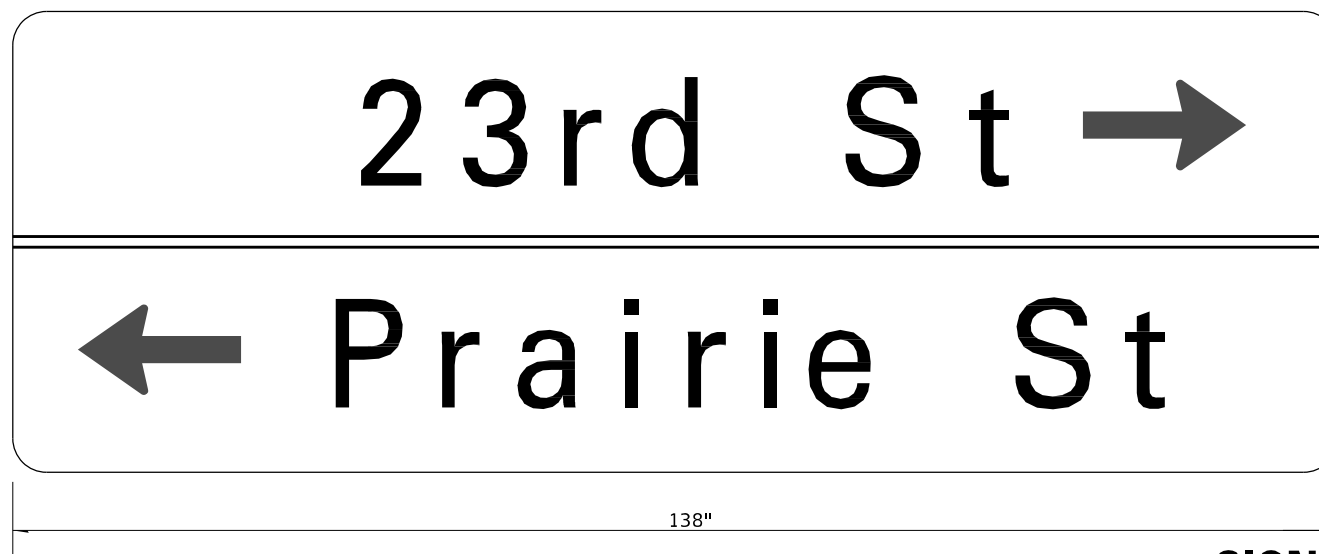

TO BE INSTALLED ON WESTBOUND MAST ARM (STA 122+67 52.8' LT)

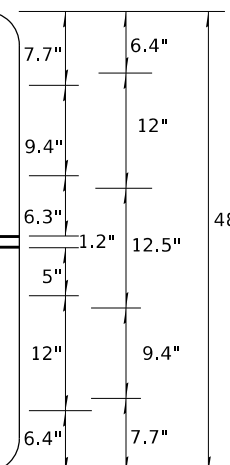

SIGN PANEL DETAILS

MODEL: Default
FILE: \\nas01c.psu.edu\pub\baronm.d\allink\scop\RWIDOT\Documents\DOT_Offices\Dist\ct 7\Projects\24710\CADData\CAD\Sheet\074710_T5-05_36_6_Prairie_St.dgn

USER NAME = steffemk	DESIGNED -	REVISED -
	DRAWN -	REVISED -
PLOT SCALE = 19.9998 ' / in.	CHECKED -	REVISED -
PLOT DATE = 2/20/2020	DATE -	REVISED -

**STATE OF ILLINOIS
DEPARTMENT OF TRANSPORTATION**

**INTERSECTION OF US RTE 36 & PRAIRIE ST
SIGN PANNEL DETAILS**

SCALE: SHEET OF SHEETS STA. TO STA.

F.A.P. RTE.	SECTION	COUNTY	TOTAL SHEETS	SHEET NO.
320	(137Z, 139-X-2)RS-2	MACON	262	222
CONTRACT NO. 74710				
ILLINOIS FED. AID PROJECT				

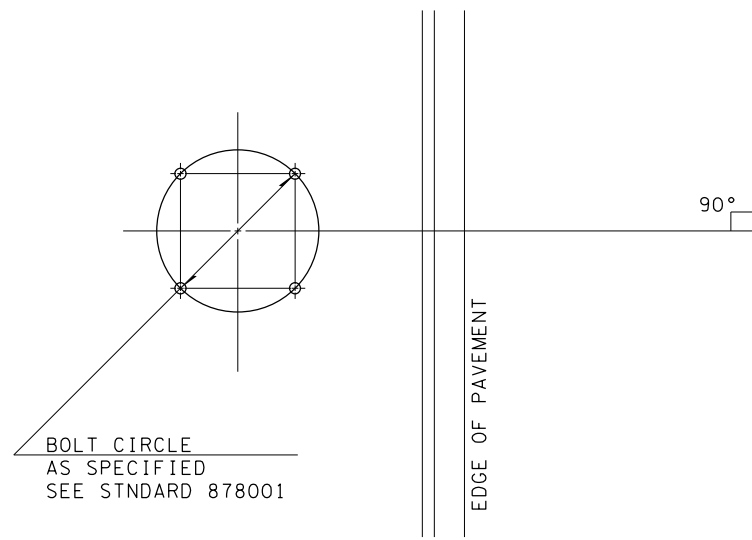

DETAIL OF MAST ARM FOUNDATION
BOLT PATTERN

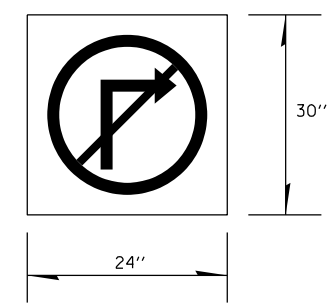

ILLUMINATED SIGN, LED

LED BLANK OUT, RAILROAD PRE-EMPTIVE ACTIVATION

TO INSTALLED ON TRAFFIC SIGNAL POST (STA 124+04 39' LT)
TO INSTALLED ON TRAFFIC SIGNAL MAST ARM (STA 122+67 52.8' LT)

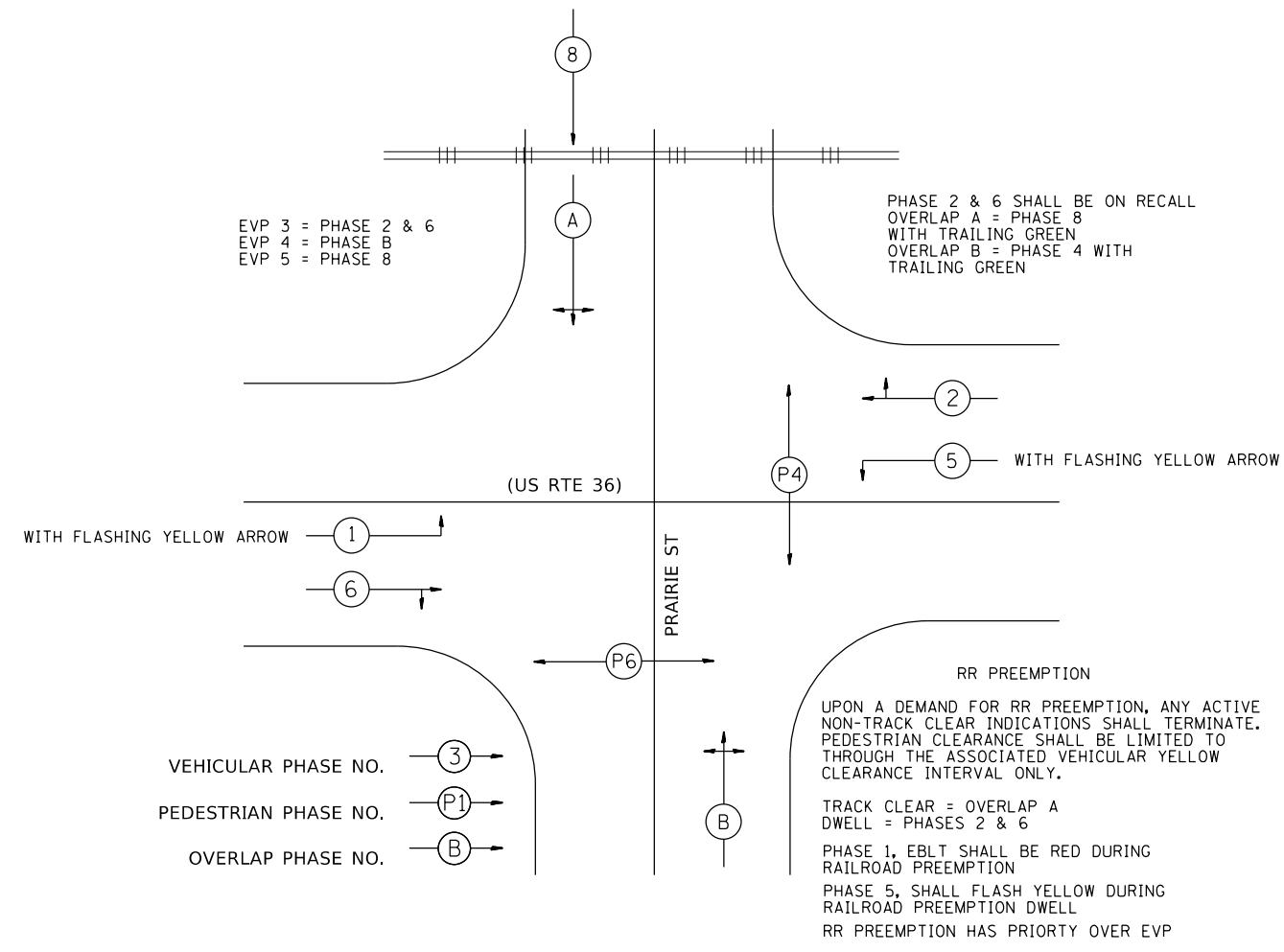

PHASE DESIGNATION DIAGRAM

FILE NAME =	USER NAME = steffenk	DESIGNED -	REVISED -
pw:\planroom\dot\illinois.gov\PWDOT\Documents\DOT Offices\District 7\Projects\74710\CADData\CADsheets\I0774710		DRAWN -	REVISED -
Default	PLOT SCALE = 20,0000' / 1"	CHECKED -	REVISED -
	PLOT DATE = 2/20/2020	DATE -	REVISED -

STATE OF ILLINOIS
DEPARTMENT OF TRANSPORTATION

INTERSECTION OF (US RTE 36) & PRAIRIE ST
DETAILS

SCALE:	SHEET	OF	SHEETS	STA.	TO STA.
--------	-------	----	--------	------	---------

F.A.P. RTE.	SECTION	COUNTY	TOTAL SHEETS	SHEET NO.
320	(137Z, 139-X-2)RS-2	MACON	262	223
CONTRACT NO. 74710				
ILLINOIS FED. AID PROJECT				

US RTE 36 & PRAIRIE STREET ST-BILL OF MATERIALS

ITEM	UNIT	QUANTITY
SIGN PANEL-TYPE 1	SQ FT	62
SIGN PANEL-TYPE 3	SQ FT	92
SERVICE INSTALLATION, TYPE A	EACH	1
UNDERGROUND CONDUIT, PVC 3/4" DIA.	FOOT	131
UNDERGROUND CONDUIT, PVC 1 1/2" DIA.	FOOT	151
UNDERGROUND CONDUIT, PVC 2" DIA.	FOOT	158
UNDERGROUND CONDUIT, PVC 4" DIA.	FOOT	468
UNDERGROUND CONDUIT, PVC 5" DIA.	FOOT	8
HANDHOLE	EACH	12
DOUBLE HANDHOLE	EACH	1
GULFBOX JUNCTION	EACH	4
MAINTENANCE OF EXISTING TRAFFIC SIGNAL INSTALLATION	EACH	1
RAILROAD FULL-ACTUATED CONTROLLER AND TYPE IV CABINET	EACH	1
UNINTERRUPTABLE POWER SUPPLY, EXTENDED	EACH	1
TRANSCEIVER-FIBER OPTIC	EACH	1
ELECTRIC CABLE IN CONDUIT, SIGNAL NO 14 3C	FOOT	1243
ELECTRIC CABLE IN CONDUIT, SIGNAL NO 14 5C	FOOT	2959
ELECTRIC CABLE IN CONDUIT, SIGNAL NO 14 7C	FOOT	1260
ELECTRIC CABLE IN CONDUIT, LEAD-IN NO 14 1 PAIR	FOOT	1861
ELECTRIC CABLE IN CONDUIT, RAILROAD, NO 14 3C	FOOT	128
ELECTRIC CABLE IN CONDUIT, SERVICE, NO 6 2C	FOOT	17
ELECTRIC CABLE IN CONDUIT, EQUIPMENT GROUNDING CONDUCTOR, NO 6 1C	FOOT	821
TRAFFIC SIGNAL POST, GALVANIZED STEEL 12 FT	EACH	1
TRAFFIC SIGNAL POST, GALVANIZED STEEL 14 FT	EACH	3
TRAFFIC SIGNAL POST, GALVANIZED STEEL 16 FT	EACH	2
TRAFFIC SIGNAL POST, GALVANIZED STEEL 18 FT	EACH	2
STEEL MAST ARM ASSEMBLY AND POLE, 26 FT	EACH	1
STEEL MAST ARM ASSEMBLY AND POLE, 46 FT	EACH	1
STEEL MAST ARM ASSEMBLY AND POLE, 54 FT	EACH	1
CONCRETE FOUNDATION, TYPE A	FOOT	24
CONCRETE FOUNDATION, TYPE C	FOOT	3.5
CONCRETE FOUNDATION, TYPE E 30-INCH DIAMETER	FOOT	10
CONCRETE FOUNDATION, TYPE E 36-INCH DIAMETER	FOOT	28
DRILL EXISTING HANDHOLE	EACH	1
SIGNAL HEAD, POLYCARBONATE, LED, 1-FACE, 3-SECTION, BRACKET MOUNTED	EACH	4
SIGNAL HEAD, POLYCARBONATE, LED, 1-FACE, 3-SECTION, MAST ARM MOUNTED	EACH	7
SIGNAL HEAD, POLYCARBONATE, LED, 1-FACE, 4-SECTION, BRACKET MOUNTED	EACH	1
SIGNAL HEAD, POLYCARBONATE, LED, 1-FACE, 4-SECTION, MAST ARM MOUNTED	EACH	2
SIGNAL HEAD, POLYCARBONATE, LED, 2-FACE, 1-3-SECTION, 1-4-SECTION BRACKET MOUNTED	EACH	3
PEDESTRIAN SIGNAL HEAD, POLYCARBONATE, LED, 1-FACE, BRACKET MOUNTED	EACH	4
TRAFFIC SIGNAL BACKPLATE, LOUVERED, FORMED PLASTIC	EACH	20
INDUCTIVE LOOP DETECTOR	EACH	12
DETECTOR LOOP, TYPE 1	FOOT	1153
PEDESTRIAN PUSH-BUTTON	EACH	4
REMOVE EXISTING SERVICE INSTALLATION	EACH	1
REMOVE EXISTING TRAFFIC SIGNAL EQUIPMENT	EACH	1
REMOVE EXISTING HANDHOLE	EACH	10
REMOVE EXISTING CONCRETE FOUNDATION	EACH	10
SPARE FULL ACTUATED CONTROLLER, SPECIAL	EACH	1
ILLUMINATED SIGN, SPECIAL	EACH	2

US RTE 36 & PRAIRIE STREET ST-BILL OF MATERIALS

ITEM	UNIT	QUANTITY
EMERGENCY VEHICLE PRIORITY SYSTEM	EACH	1

MODEL: Default
 FILE: h:\a\c\p\pub\baronon.dwg
 PROJECT: 74710\CADD\DATA\CAD\sheet\DOT - Office\174710 - US 36 & Prairie St.dgn

USER NAME = steffenmk	DESIGNED -	REVISED -
PLOT SCALE = 39.9996 ' / in.	DRAWN -	REVISED -
PLOT DATE = 2/20/2020	CHECKED -	REVISED -
	DATE -	REVISED -

**STATE OF ILLINOIS
DEPARTMENT OF TRANSPORTATION**

**INTERSECTION OF US RTE 36 & PRAIRIE ST
BILL OF MATERIALS**

SCALE: SHEET OF SHEETS STA. TO STA.

F.A.P. RTE.	SECTION	COUNTY	TOTAL SHEETS	SHEET NO.
320	(137Z, 139-X-2)RS-2	MACON	262	224
CONTRACT NO. 74710				
ILLINOIS FED. AID PROJECT				

MODEL: Default
 FILE: \\blm1c:\pub\baronm.dwg
 PROJECT: 74710\CAAD\DATA\CADD\Drawings\DOT\Office\Drawings\74710\74710 TS-US 36 & Prairie St.dwg

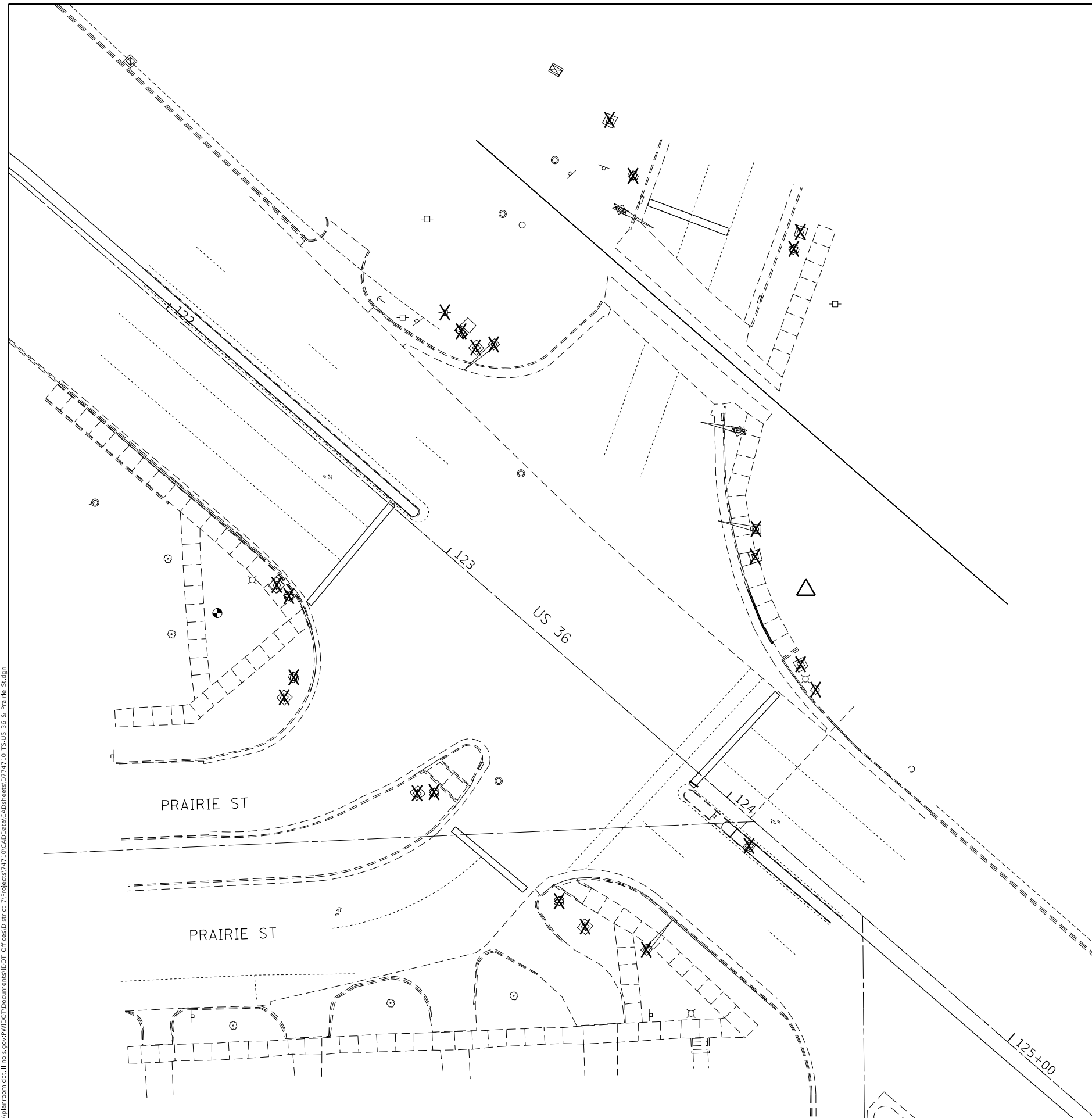

REMOVAL ITEMS

		Total	NW	NE	SE	SW	Islands
Remove Existing Service Installation	Each	1	-	1	-	-	-
Remove Existing Handhole	Each	10	2	2	3	1	2
Remove Existing Double Handhole	Each	-	-	-	-	-	-
Remove Existing Concrete Foundation	Each	10	2	2	3	2	1
Remove Existing Traffic Signal Equipment	Each	1	-	-	-	-	-

• See individual items below.

REMOVE EXISTING TRAFFIC SIGNAL EQUIPMENT

(QUANTITY: 1 EACH)

	Total	NW	NE	SE	SW	Island
Pedestrian Signal Head	4	1	-	1	2	-
Pedestrian Push-Button	4	1	-	2	1	-
Pedestrian Push Button Post	-	-	-	-	-	-
Traffic Signal Head-3 Section BM	8	2	2	3	1	-
Traffic Signal Head-5 Section BM	2	1	-	1	-	-
Traffic Signal Head-4 Section BM	2	-	-	-	1	1
Traffic Signal Head-3 Section MAM	3	-	1	1	1	-
Traffic Signal Head-3 Section RR Truss Mounted	1	1	-	-	-	-
Traffic Signal Head-5 Section MAM	2	1	-	1	-	-
Traffic Signal Post	7	2	1	2	1	1
Traffic Signal Mast Arm	3	1	1	1	-	-
Traffic Signal Cabinet, Controller & Components	1	-	1	-	-	-
Gulfbox Junction	-	-	-	-	-	-
Illuminated Sign, LED MAM	-	-	1	-	1	-
Illuminated Sign, LED BM	-	-	-	2	-	-

THE EXISTING SIGNALS WILL BE MAINTAINED UNTIL THE PROPOSED IS ALL INSTALLED AND OPERATIONAL. THEN THE EXISTING WILL BE REMOVED.

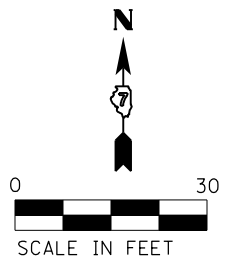

USER NAME = steffemk	DESIGNED -	REVISED -
	DRAWN -	REVISED -
PLOT SCALE = 30.0000' / in.	CHECKED -	REVISED -
PLOT DATE = 2/20/2020	DATE -	REVISED -

**STATE OF ILLINOIS
DEPARTMENT OF TRANSPORTATION**

**INTERSECTION OF US RTE 36 & PRAIRIE ST
REMOVAL ITEMS**

SCALE: SHEET OF SHEETS STA. TO STA.

F.A.P. RTE.	SECTION	COUNTY	TOTAL SHEETS	SHEET NO.
320	(137Z, 139-X-2)RS-2	MACON	262	225
CONTRACT NO. 74710				

ILLINOIS FED. AID PROJECT

MODEL: Default
 FILE: \\bls01\pub\baronm\dot\illinois\gov\pww\DOT\Documents\DOT - Offices\District 7\Projects\74710\CADD\Drawings\74710_15-US 36 & Prairie St.dwg
 PROJECT: 74710

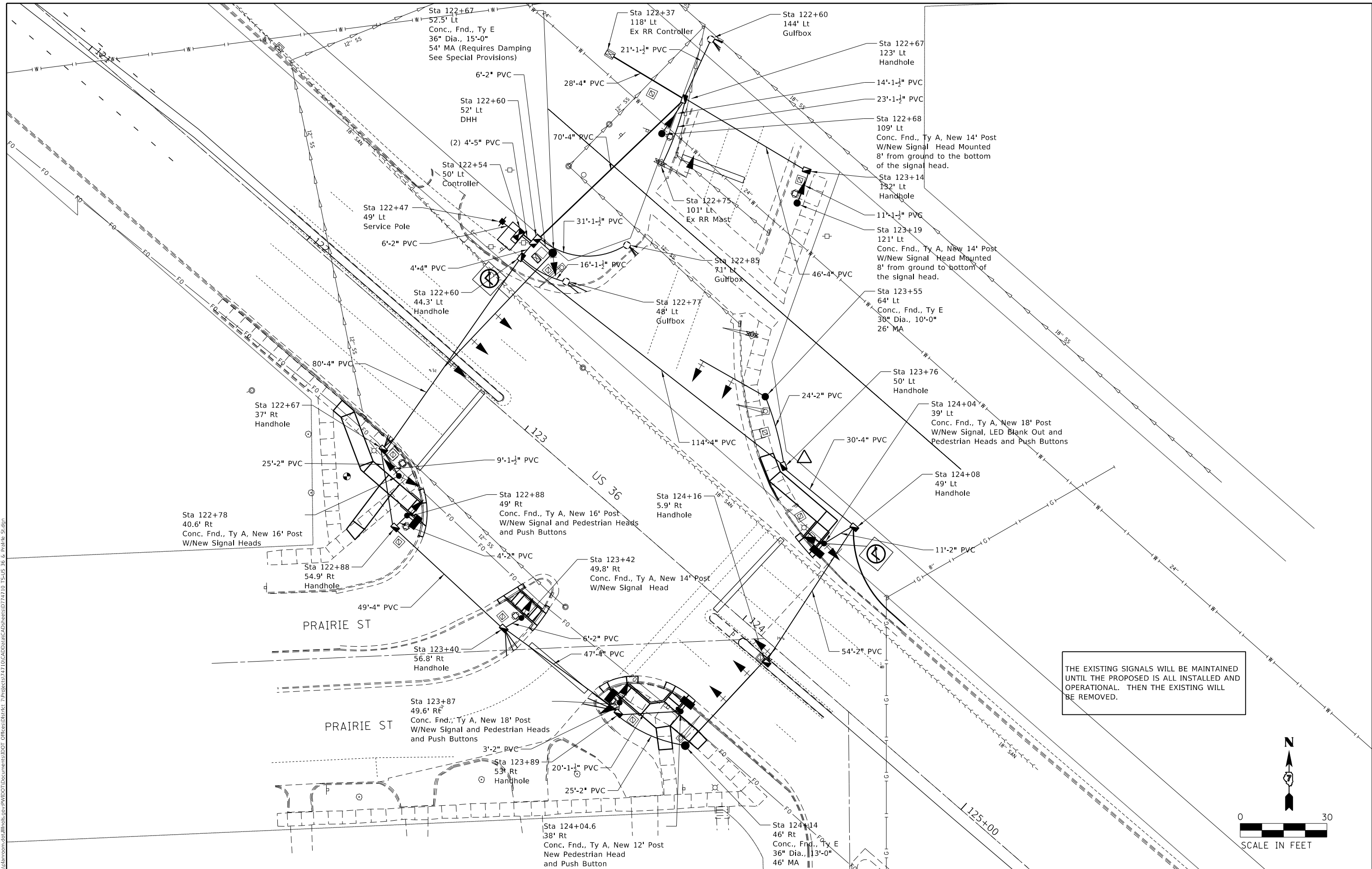

USER NAME = steffenmk	DESIGNED -	REVISED -
	DRAWN -	REVISED -
PLOT SCALE = 30.0000' / in.	CHECKED -	REVISED -
PLOT DATE = 2/20/2020	DATE -	REVISED -

STATE OF ILLINOIS
DEPARTMENT OF TRANSPORTATION

INTERSECTION OF US RTE 36 & PRAIRIE ST
SIGNAL LAYOUT

F.A.P. RTE.	SECTION	COUNTY	TOTAL SHEETS	SHEET NO.
320	(137Z, 139-X-2)RS-2	MACON	262	226
CONTRACT NO. 74710				
ILLINOIS		FED. AID PROJECT		

SCALE: SHEET OF SHEETS STA. TO STA.

MODEL: Default
 FILE: \\s:\s\p\pub\baronm.dwg
 PROJECT: 74710\CADD\DATA\CAD\Sheet\74710_T5-US 36 & Prairie St.dwg
 OFFICE: D:\IT\74710\CADD\DATA\CAD\Sheet\74710_T5-US 36 & Prairie St.dwg
 DATE: 2/20/2020

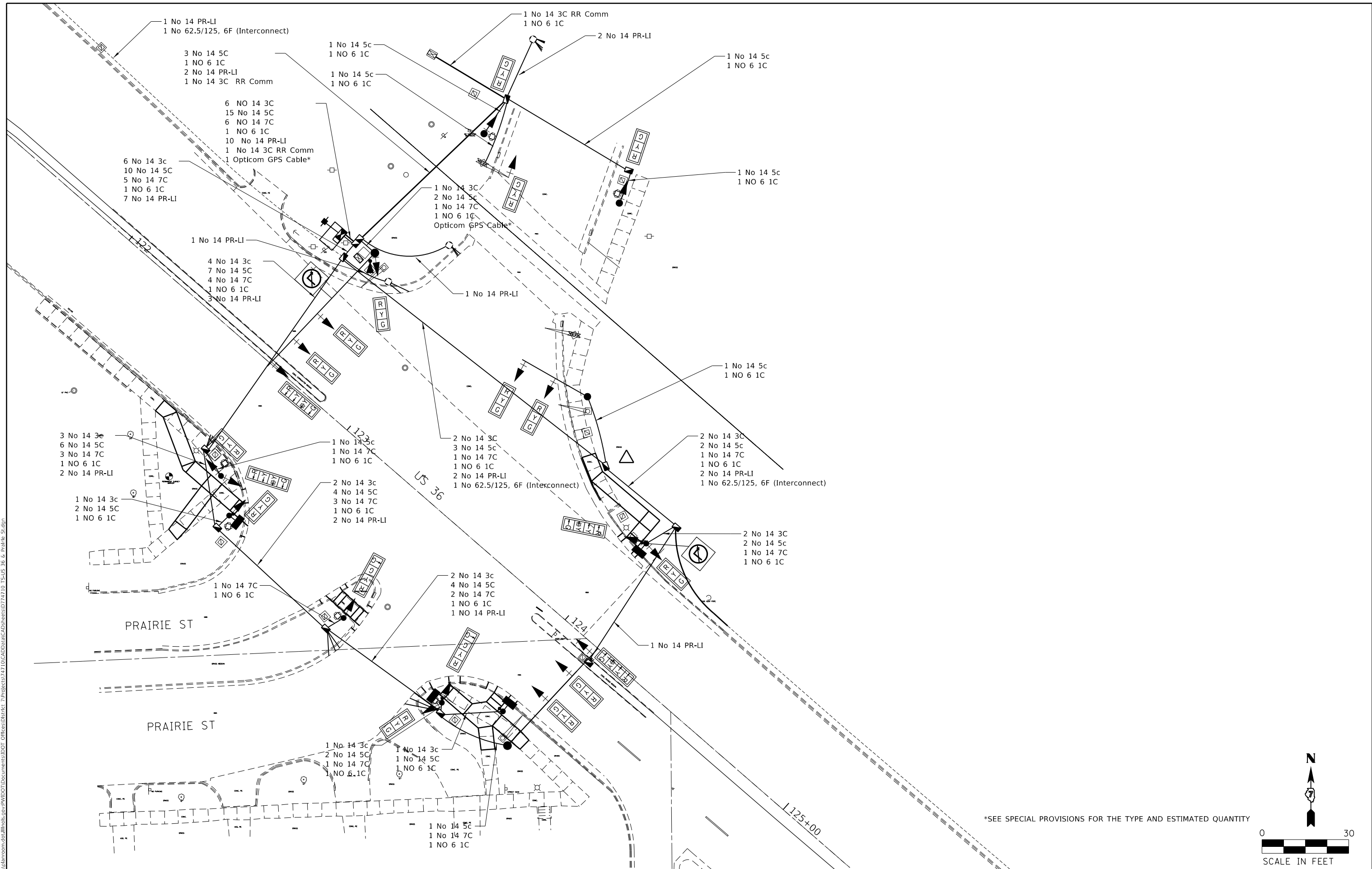

*SEE SPECIAL PROVISIONS FOR THE TYPE AND ESTIMATED QUANTITY

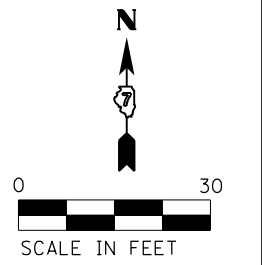

USER NAME = stefenmk	DESIGNED -	REVISED -
	DRAWN -	REVISED -
PLOT SCALE = 30.0000 ' / in.	CHECKED -	REVISED -
PLOT DATE = 2/20/2020	DATE -	REVISED -

STATE OF ILLINOIS
DEPARTMENT OF TRANSPORTATION

INTERSECTION OF US RTE 36 & PRAIRIE ST
CABLE LAYOUT

SCALE: SHEET OF SHEETS STA. TO STA.

F.A.P. RTE.	SECTION	COUNTY	TOTAL SHEETS	SHEET NO.
320	(137Z, 139-X-2)RS-2	MACON	262	227
CONTRACT NO. 74710				
ILLINOIS FED. AID PROJECT				

MODEL: Default
 FILE: \\nas01c.pw.state.il.us\pub\baronm.d\at\links\pwr\WDDOT\Documents\DOT_Offices\District_7\Projects\74710\CADD\data\CAD\sheet\74710_T5-LS 36 & Prairie St.dgn

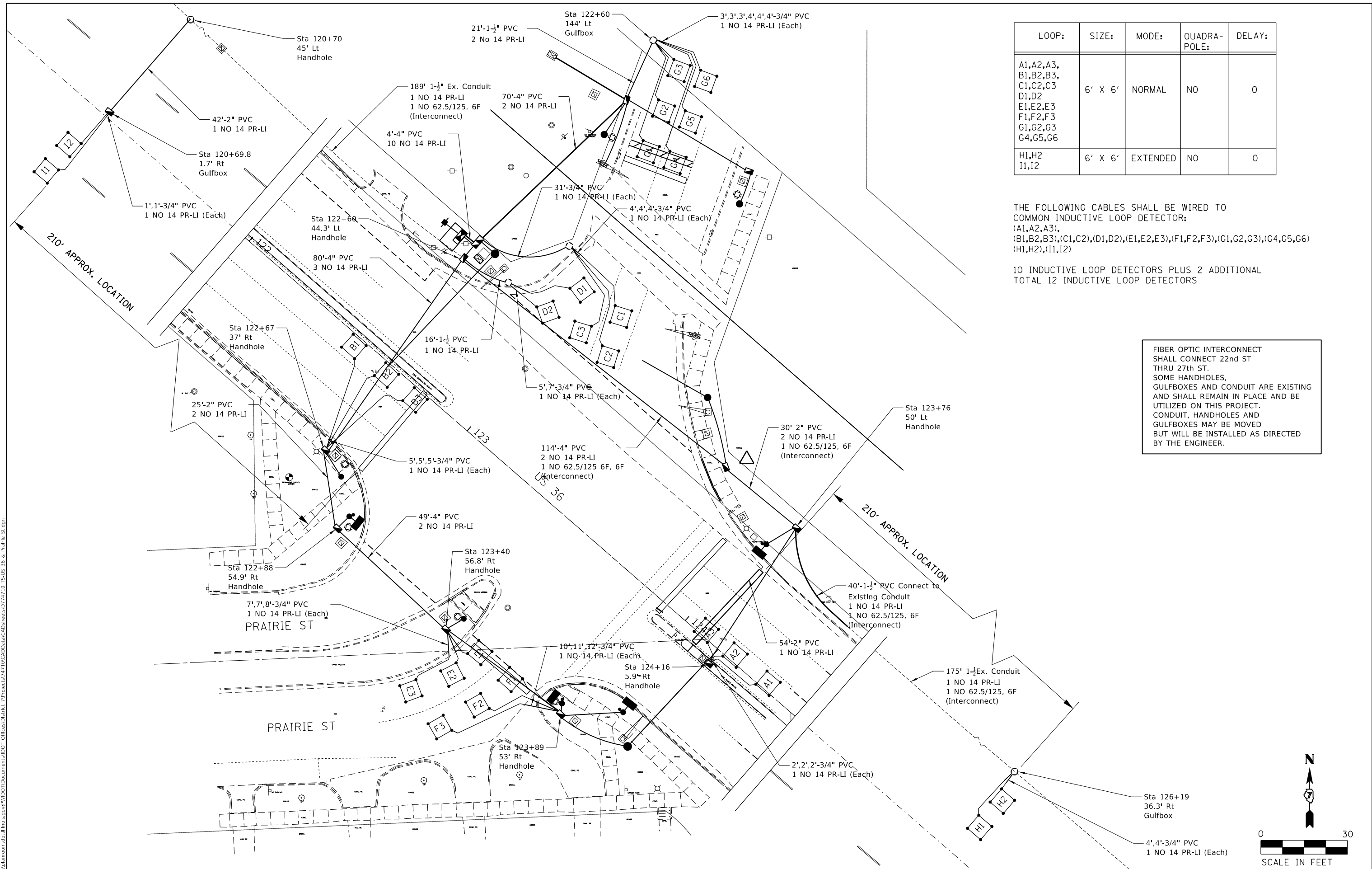

LOOP:	SIZE:	MODE:	QUADRA-POLE:	DELAY:
A1,A2,A3, B1,B2,B3, C1,C2,C3 D1,D2 E1,E2,E3 F1,F2,F3 G1,G2,G3 G4,G5,G6	6' X 6'	NORMAL	NO	0
H1,H2 I1,I2	6' X 6'	EXTENDED	NO	0

THE FOLLOWING CABLES SHALL BE WIRED TO COMMON INDUCTIVE LOOP DETECTOR:
 (A1,A2,A3), (B1,B2,B3), (C1,C2), (D1,D2), (E1,E2,E3), (F1,F2,F3), (G1,G2,G3), (G4,G5,G6), (H1,H2), (I1,I2)

10 INDUCTIVE LOOP DETECTORS PLUS 2 ADDITIONAL TOTAL 12 INDUCTIVE LOOP DETECTORS

FIBER OPTIC INTERCONNECT SHALL CONNECT 22nd ST THRU 27th ST. SOME HANDHOLES, GULFBBOXES AND CONDUIT ARE EXISTING AND SHALL REMAIN IN PLACE AND BE UTILIZED ON THIS PROJECT. CONDUIT, HANDHOLES AND GULFBBOXES MAY BE MOVED BUT WILL BE INSTALLED AS DIRECTED BY THE ENGINEER.

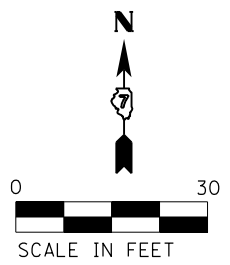

USER NAME = steffemk	DESIGNED -	REVISED -
	DRAWN -	REVISED -
PLOT SCALE = 30.0000' / in.	CHECKED -	REVISED -
PLOT DATE = 2/20/2020	DATE -	REVISED -

**STATE OF ILLINOIS
 DEPARTMENT OF TRANSPORTATION**

INTERSECTION OF US RTE 36 & PRAIRIE ST DETECTOR LOOPS	
SCALE:	SHEET OF SHEETS STA. TO STA.

F.A.P. RTE.	SECTION	COUNTY	TOTAL SHEETS	SHEET NO.
320	(137Z, 139-X-2)RS-2	MACON	262	228
CONTRACT NO. 74710				
ILLINOIS		FED. AID PROJECT		

SHEET LEFT BLANK FOR INSERTION OF THE BORING LOGS

MODEL: Default
 FILE: \\blm1c01.pw.state.il.us\pub\lancorn\data\illinois.gov\PWD\DOT\Documents\DOT_Offices\District 7\Projects\74710\CADD\data\CAD\sheets\074710_TS-US_36 & Prairie St.dgn

USER NAME = steffenmk	DESIGNED -	REVISED -	STATE OF ILLINOIS DEPARTMENT OF TRANSPORTATION	INTERSECTION OF US RTE 36 & PRAIRIE ST BORING LOGS		F.A.P. RTE.	SECTION	COUNTY	TOTAL SHEETS	SHEET NO.
DRAWN -	REVISED -	320				(137Z, 139-X-2)RS-2	MACON	262	229	
PLOT SCALE = 19.9998 ' / in.	CHECKED -	REVISED -		SCALE: SHEET OF SHEETS STA. TO STA.		CONTRACT NO. 74710				
PLOT DATE = 2/20/2020	DATE -	REVISED -		ILLINOIS FED. AID PROJECT						

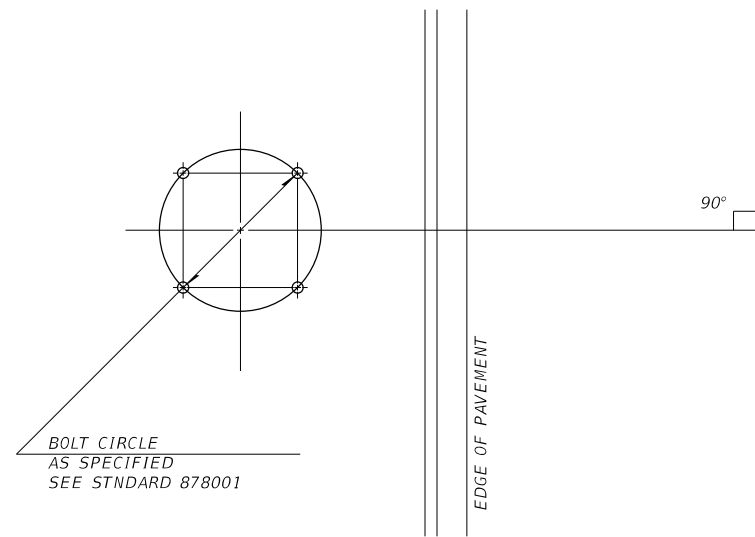

DETAIL OF MAST ARM FOUNDATION
BOLT PATTERN

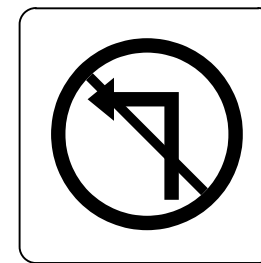

36"x36"

MUTCD SIGN DESIGNATION R3-2

TO INSTALLED ON ISLAND SIGNAL POST (STA 135+74.5 4' LT)
TO INSTALLED ON ISLAND SIGNAL POST (STA 135+44.4 4' LT)
TO INSTALLED ON ISLAND SIGNAL POST (STA 136+22 3.5' LT)

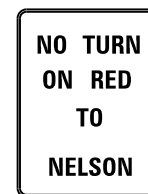

24"x30"

Black on White
MUTCD SIGN DESIGNATION R10-11

TO INSTALLED ON SB SIGNAL POST (STA 135+19 48.8' RT)

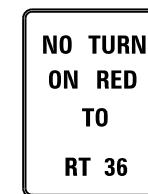

24"x30"

Black on White
MUTCD SIGN DESIGNATION R10-11

TO INSTALLED ON EB SIGNAL POST (STA 135+38.8 109.6' RT)

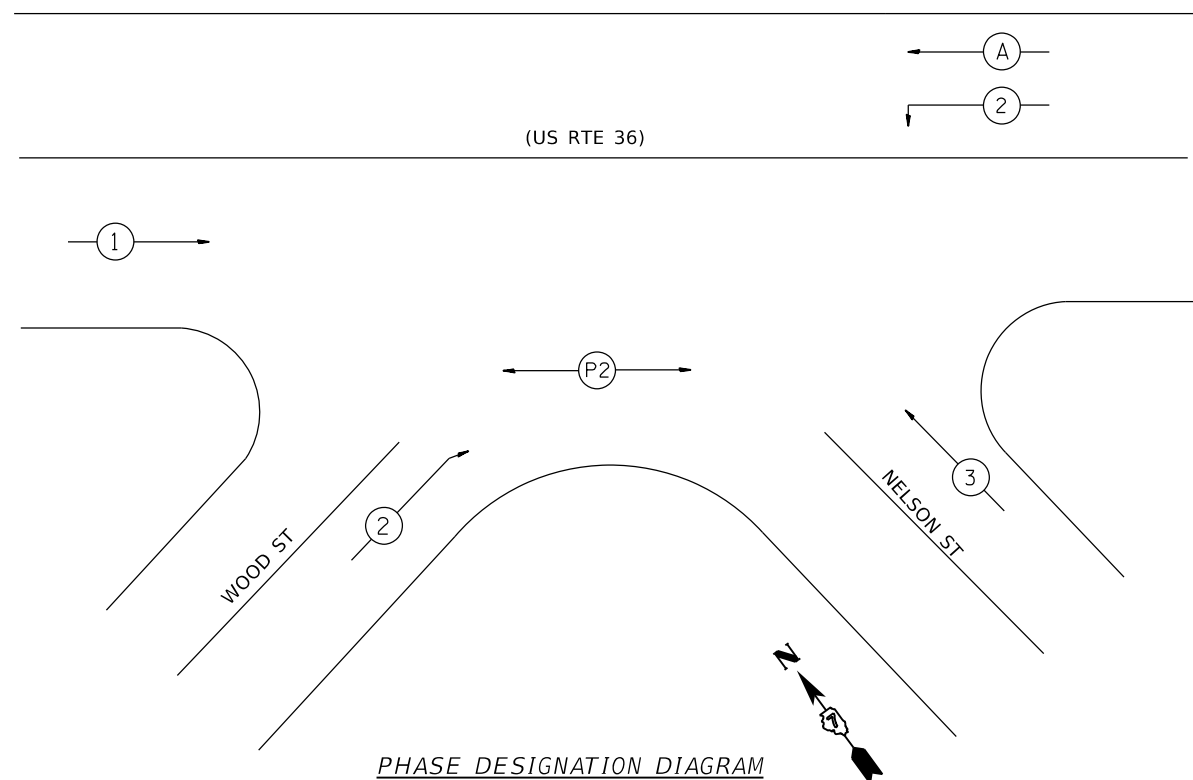

PHASE DESIGNATION DIAGRAM

SIGN PANEL DETAILS

FILE NAME =	USER NAME = steffennik	DESIGNED -	REVISED -
p:\planroom\dot\illinois.gov\PWIDOT\Documents\DOT\Projects\District 7\Projects\74710\CADData\CADsheets\ID774710		DRAWN Wood & Nelson Sldgn	REVISED -
Default	PLOT SCALE = 30,0000' / in.	CHECKED -	REVISED -
	PLOT DATE = 2/20/2020	DATE -	REVISED -

STATE OF ILLINOIS
DEPARTMENT OF TRANSPORTATION

INTERSECTION (US RTE 36) & NELSON & WOOD ST
DETAILS

SCALE: SHEET OF SHEETS STA. TO STA.

F.A.P. RTE.	SECTION	COUNTY	TOTAL SHEETS	SHEET NO.
320	(137Z,139-X-2)RS-2	MACON	262	230
CONTRACT NO. 74710				
		ILLINOIS	FED. AID PROJECT	

US RTE 36 WOOD & NELSON STREET ST-BILL OF MATERIALS

ITEM	UNIT	QUANTITY
SIGN PANEL-TYPE 1	SQ FT	10
SERVICE INSTALLATION, TYPE A	EACH	1
UNDERGROUND CONDUIT, PVC 3/4" DIA.	FOOT	95
UNDERGROUND CONDUIT, PVC 1 1/2" DIA.	FOOT	116
UNDERGROUND CONDUIT, PVC 2" DIA.	FOOT	356
UNDERGROUND CONDUIT, PVC 4" DIA.	FOOT	274
UNDERGROUND CONDUIT, PVC 5" DIA.	FOOT	12
HANDHOLE	EACH	10
DOUBLE HANDHOLE	EACH	1
GULFBOX JUNCTION	EACH	2
ELECTRIC CABLE IN CONDUIT, 600V (XLP-TYPE USE) 3-1/C NO 8	FOOT	166
MAINTENANCE OF EXISTING TRAFFIC SIGNAL INSTALLATION	EACH	1
FULL-ACTUATED CONTROLLER AND TYPE IV CABINET	EACH	1
UNINTERRUPTABLE POWER SUPPLY, EXTENDED	EACH	1
TRANSCEIVER-FIBER OPTIC	EACH	1
ELECTRIC CABLE IN CONDUIT, SIGNAL NO 14 3C	FOOT	433
ELECTRIC CABLE IN CONDUIT, SIGNAL NO 14 5C	FOOT	2944
ELECTRIC CABLE IN CONDUIT, LEAD-IN NO 14 1 PAIR	FOOT	1351
ELECTRIC CABLE IN CONDUIT, SERVICE, NO 6 2C	FOOT	14
ELECTRIC CABLE IN CONDUIT, EQUIPMENT GROUNDING CONDUCTOR, NO 6 1C	FOOT	837
TRAFFIC SIGNAL POST, GALVANIZED STEEL 12 FT	EACH	3
TRAFFIC SIGNAL POST, GALVANIZED STEEL 14 FT	EACH	8
TRAFFIC SIGNAL POST, GALVANIZED STEEL 16 FT	EACH	1
STEEL MAST ARM ASSEMBLY AND POLE, 30 FT	EACH	1
STEEL COMB MAST ARM ASSEMBLY AND POLE, 36 FT	EACH	1
CONCRETE FOUNDATION, TYPE A	FOOT	36
CONCRETE FOUNDATION, TYPE D	FOOT	3.5
CONCRETE FOUNDATION, TYPE E 30-INCH DIAMETER	FOOT	13.5
CONCRETE FOUNDATION, TYPE E 36-INCH DIAMETER	FOOT	13
DRILL EXISTING HANDHOLE	EACH	1
SIGNAL HEAD, POLYCARBONATE, LED, 1-FACE, 3-SECTION, BRACKET MOUNTED	EACH	7
SIGNAL HEAD, POLYCARBONATE, LED, 1-FACE, 3-SECTION, MAST ARM MOUNTED	EACH	6
SIGNAL HEAD, POLYCARBONATE, LED, 2-FACE, 3-SECTION, BRACKET MOUNTED	EACH	2
PEDESTRIAN SIGNAL HEAD, POLYCARBONATE, LED, 1-FACE, BRACKET MOUNTED WITH COUNTDOWN TIMER	EACH	4
TRAFFIC SIGNAL BACKPLATE, LOUVERED, FORMED PLASTIC	EACH	17
DIRECTIONAL LOUVERS, TYPE B	EACH	2
INDUCTIVE LOOP DETECTOR	EACH	10
DETECTOR LOOP, TYPE 1	FOOT	857
PEDESTRIAN PUSH-BUTTON	EACH	4
REMOVE EXISTING SERVICE INSTALLATION	EACH	1
REMOVE EXISTING TRAFFIC SIGNAL EQUIPMENT	EACH	1
REMOVE EXISTING HANDHOLE	EACH	6
REMOVE EXISTING CONCRETE FOUNDATION	EACH	9
LUMINAIRE (SPECIAL)	EACH	1
EMERGENCY VEHICLE PRIORITY SYSTEM	EACH	1

MODEL: Default
FILE: h:\mhc\p\pub\haronom.dwg
PROJECT: 171710\CADD\DATA\CAD\SheetSet\171710_T5-JUS 36 & E Wood & Nelson St.dgn

*F.A.P. 323 & F.A.U. 7404

USER NAME = steffemk DESIGNED - DRAWN - PLOT SCALE = 39.9996 ' / in. CHECKED - DATE -	REVISED - REVISED - REVISED - REVISED -	STATE OF ILLINOIS DEPARTMENT OF TRANSPORTATION	INTERSECTION OF US RTE 36 & NELSON & WOOD ST BILL OF MATERIALS		F.A.P. RTE.	SECTION	COUNTY	TOTAL SHEETS	SHEET NO.
			320	(137Z, 139-X-2)RS-2	MACON	262	231		
SCALE: SHEET OF SHEETS STA. TO STA.			CONTRACT NO. 74710		ILLINOIS FED. AID PROJECT				

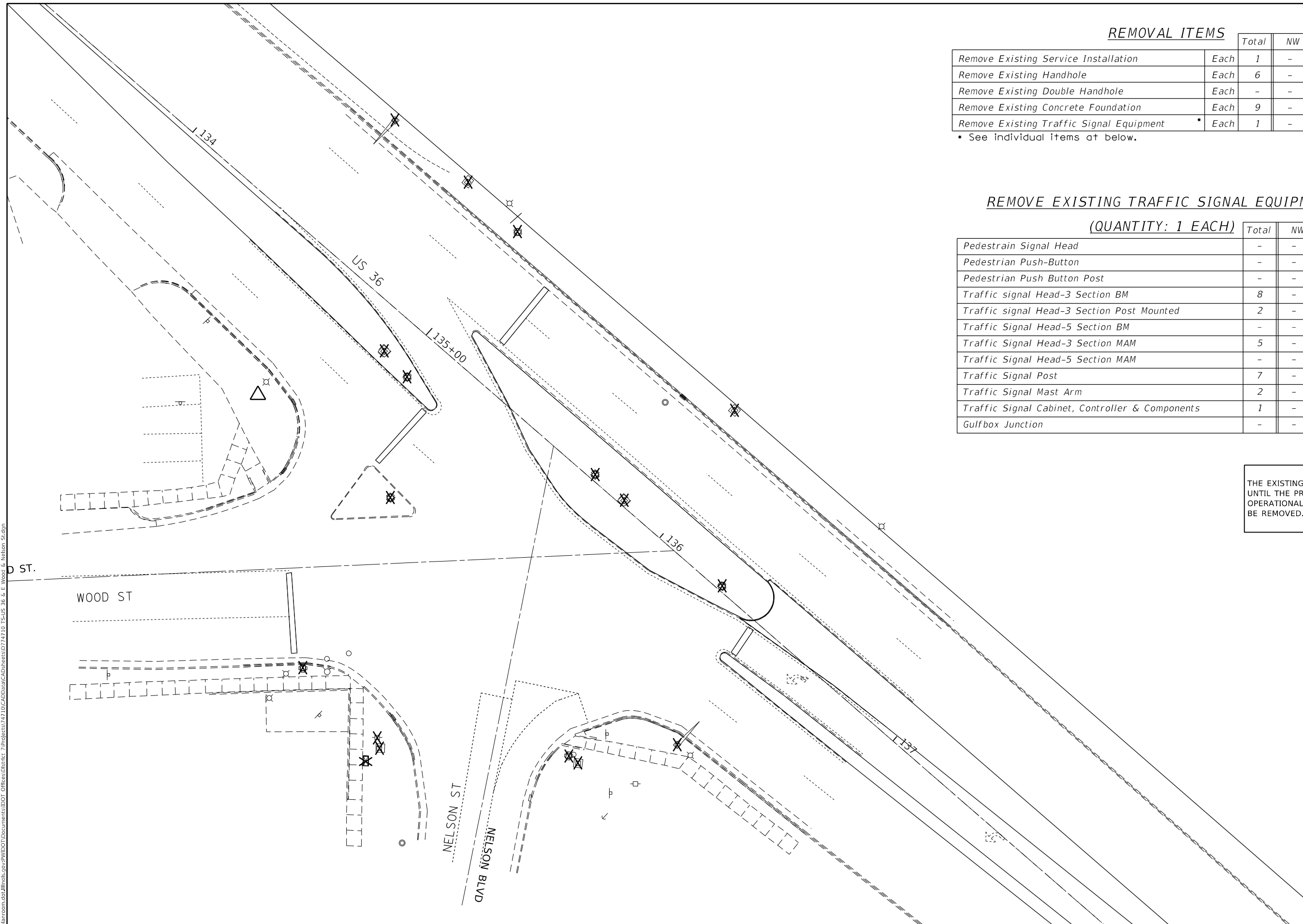

REMOVAL ITEMS

		Total	NW	NE	Island	SE	SW
Remove Existing Service Installation	Each	1	-	-	-	-	1
Remove Existing Handhole	Each	6	-	2	2	1	1
Remove Existing Double Handhole	Each	-	-	-	-	-	-
Remove Existing Concrete Foundation	Each	9	-	2	4	2	1
Remove Existing Traffic Signal Equipment	Each	1	-	-	-	-	-

• See individual items at below.

REMOVE EXISTING TRAFFIC SIGNAL EQUIPMENT

(QUANTITY: 1 EACH)

	Total	NW	NE	Island	SE	SW
Pedestrian Signal Head	-	-	-	-	-	-
Pedestrian Push-Button	-	-	-	-	-	-
Pedestrian Push Button Post	-	-	-	-	-	-
Traffic signal Head-3 Section BM	8	-	1	6	-	1
Traffic signal Head-3 Section Post Mounted	2	-	-	1	-	1
Traffic Signal Head-5 Section BM	-	-	-	-	-	-
Traffic Signal Head-3 Section MAM	5	-	2	-	3	-
Traffic Signal Head-5 Section MAM	-	-	-	-	-	-
Traffic Signal Post	7	-	1	4	1	1
Traffic Signal Mast Arm	2	-	1	-	1	-
Traffic Signal Cabinet, Controller & Components	1	-	-	-	-	1
Gulfbox Junction	-	-	-	-	-	-

THE EXISTING SIGNALS WILL BE MAINTAINED UNTIL THE PROPOSED IS ALL INSTALLED AND OPERATIONAL. THEN THE EXISTING WILL BE REMOVED.

MODEL: Default
 FILE: \\blm1c01.pw.state.il.us\pub\baronm.d\at\illinois.gov\PWIDOT\Documents\DOT_Offices\District 7\Projects\74710\CADD\Drawings\74710_T5-US 36 & E Wood & Nelson Station

USER NAME = steffemk	DESIGNED -	REVISED -
	DRAWN -	REVISED -
PLOT SCALE = 30.0000 ' / in.	CHECKED -	REVISED -
PLOT DATE = 2/20/2020	DATE -	REVISED -

**STATE OF ILLINOIS
DEPARTMENT OF TRANSPORTATION**

**INTERSECTION OF US RTE 36 & WOOD & NELSON ST
REMOVAL LAYOUT**

SCALE: SHEET OF SHEETS STA. TO STA.

F.A.P. RTE.	SECTION	COUNTY	TOTAL SHEETS	SHEET NO.
320	(137z, 139-X-2)RS-2	MACON	262	232
CONTRACT NO. 74710			ILLINOIS FED. AID PROJECT	

MODEL: Default
FILE: \\msb\c:\pub\baronm\ada\illinois\p\w\DOT\Documents\DOT - Offices\District 7\Projects\74710\CADD\DATA\DWG\Sheet\74710_US 36 & E. Wood & Nelson Station

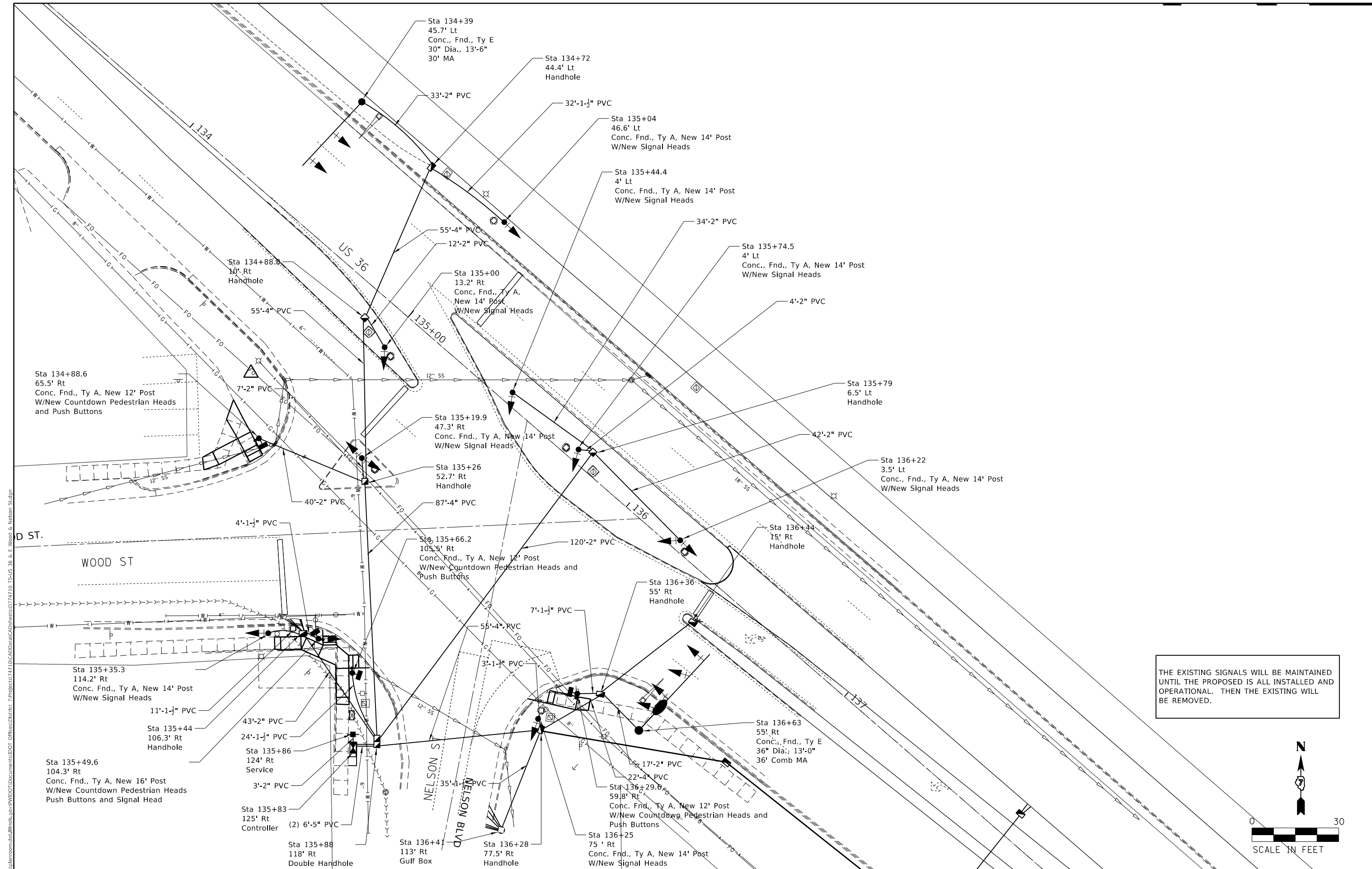

THE EXISTING SIGNALS WILL BE MAINTAINED UNTIL THE PROPOSED IS ALL INSTALLED AND OPERATIONAL. THEN THE EXISTING WILL BE REMOVED.

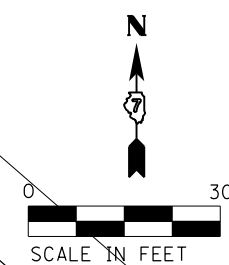

USER NAME = stefenmk	DESIGNED -	REVISED -
	DRAWN -	REVISED -
PLOT SCALE = 30,0000 ' / in.	CHECKED -	REVISED -
PLOT DATE = 2/20/2020	DATE -	REVISED -

**STATE OF ILLINOIS
DEPARTMENT OF TRANSPORTATION**

**INTERSECTION OF US RTE 36 & WOOD & NELSON ST
SIGNAL LAYOUT**

SCALE: _____ SHEET _____ OF _____ SHEETS STA. _____ TO STA. _____

F.A.P. RTE.	SECTION	COUNTY	TOTAL SHEETS	SHEET NO.
320	(137z, 139-X-2)RS-2	MACON	262	233
CONTRACT NO. 74710				
ILLINOIS FED. AID PROJECT				

MODEL: Default
 FILE: \\blm1c:\pub\baronm\ada\illinois\gov\PIWDOT\Documents\DOT_Offices\District 7\Projects\74710\CADD\data\CAD\sheet\74710_T54US 36 & E Wood & Nelson Station

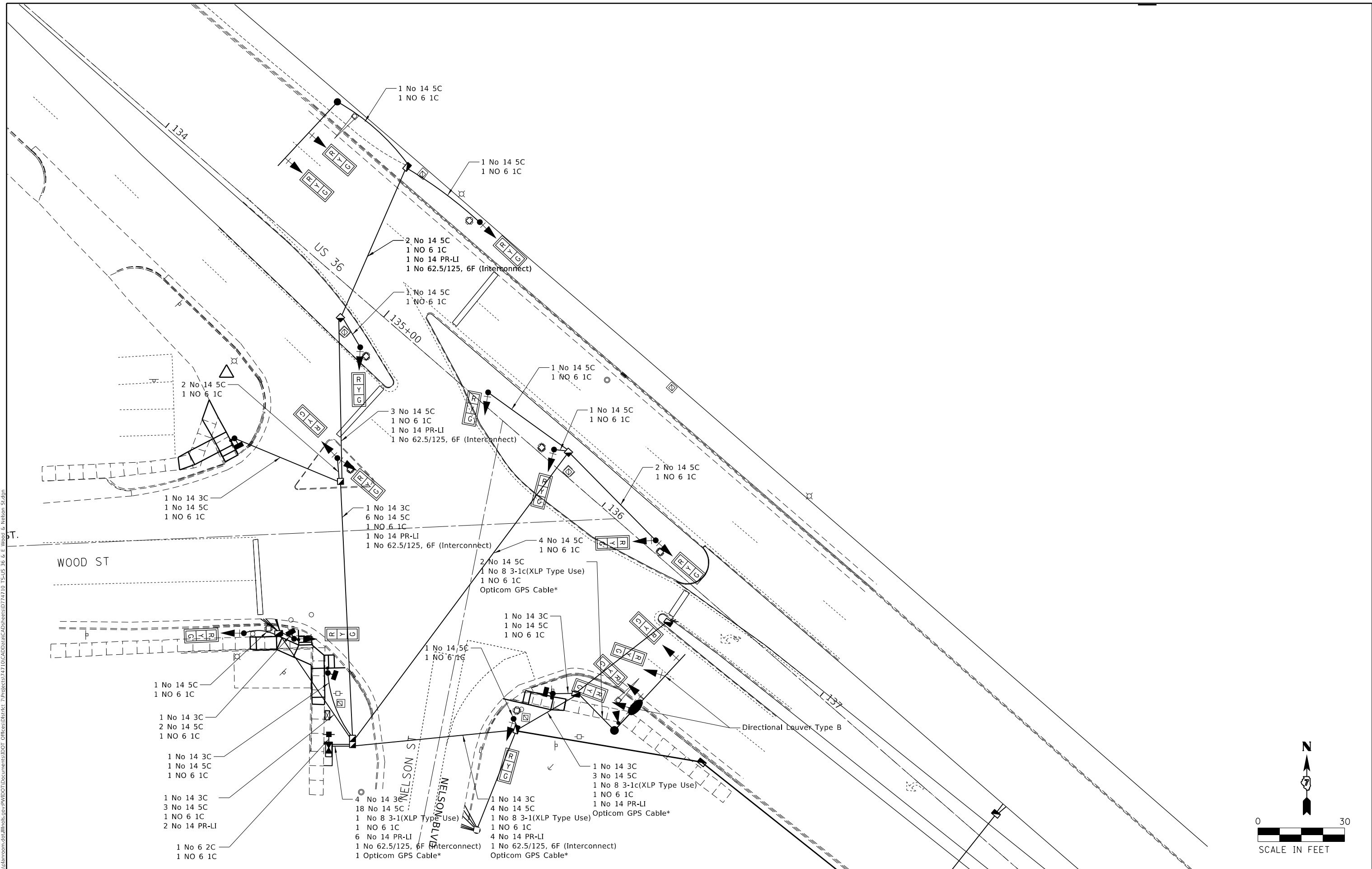

USER NAME = steffemk	DESIGNED -	REVISED -
	DRAWN -	REVISED -
PLOT SCALE = 30.0000 ' / in.	CHECKED -	REVISED -
PLOT DATE = 2/20/2020	DATE -	REVISED -

STATE OF ILLINOIS
DEPARTMENT OF TRANSPORTATION

INTERSECTION OF US RTE 36 & WOOD & NELSON ST			
CABLE LAYOUT			
SCALE:	SHEET	OF SHEETS	STA. TO STA.

F.A.P. RTE.	SECTION	COUNTY	TOTAL SHEETS	SHEET NO.
320	(137z, 139-X-2)RS-2	MACON	262	234
CONTRACT NO. 74710				
ILLINOIS FED. AID PROJECT				

LOOP:	SIZE:	MODE:	QUADRA-POLE:	DELAY:
A1,A2,A3, A4,A5,A6 B1,B2,B3, B4,B5,B6 C1,C2,C3	6' X 6'	NORMAL	NO	0
D1,D2 E1,E2	6' X 6'	EXTENDED	NO	0

THE FOLLOWING CABLES SHALL BE WIRED TO COMMON INDUCTIVE LOOP DETECTOR:
(A1,A2,A3),(A4,A5,A6),(B1,B2,B3),(B4,B5,B6),(C1,C2,C3)
(D1,D2),(E1,E2)

7 INDUCTIVE LOOP DETECTORS PLUS 3 ADDITIONAL
TOTAL 10 INDUCTIVE LOOP DETECTORS

FIBER OPTIC INTERCONNECT SHALL CONNECT 22nd ST THRU 27th ST. SOME HANDHOLES, GULFBOXES AND CONDUIT ARE EXISTING AND SHALL REMAIN IN PLACE AND BE UTILIZED ON THIS PROJECT. CONDUIT, HANDHOLES AND GULFBOXES MAY BE MOVED BUT WILL BE INSTALLED AS DIRECTED BY THE ENGINEER.

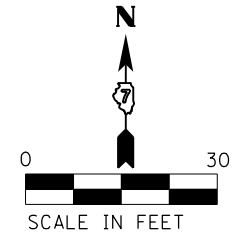
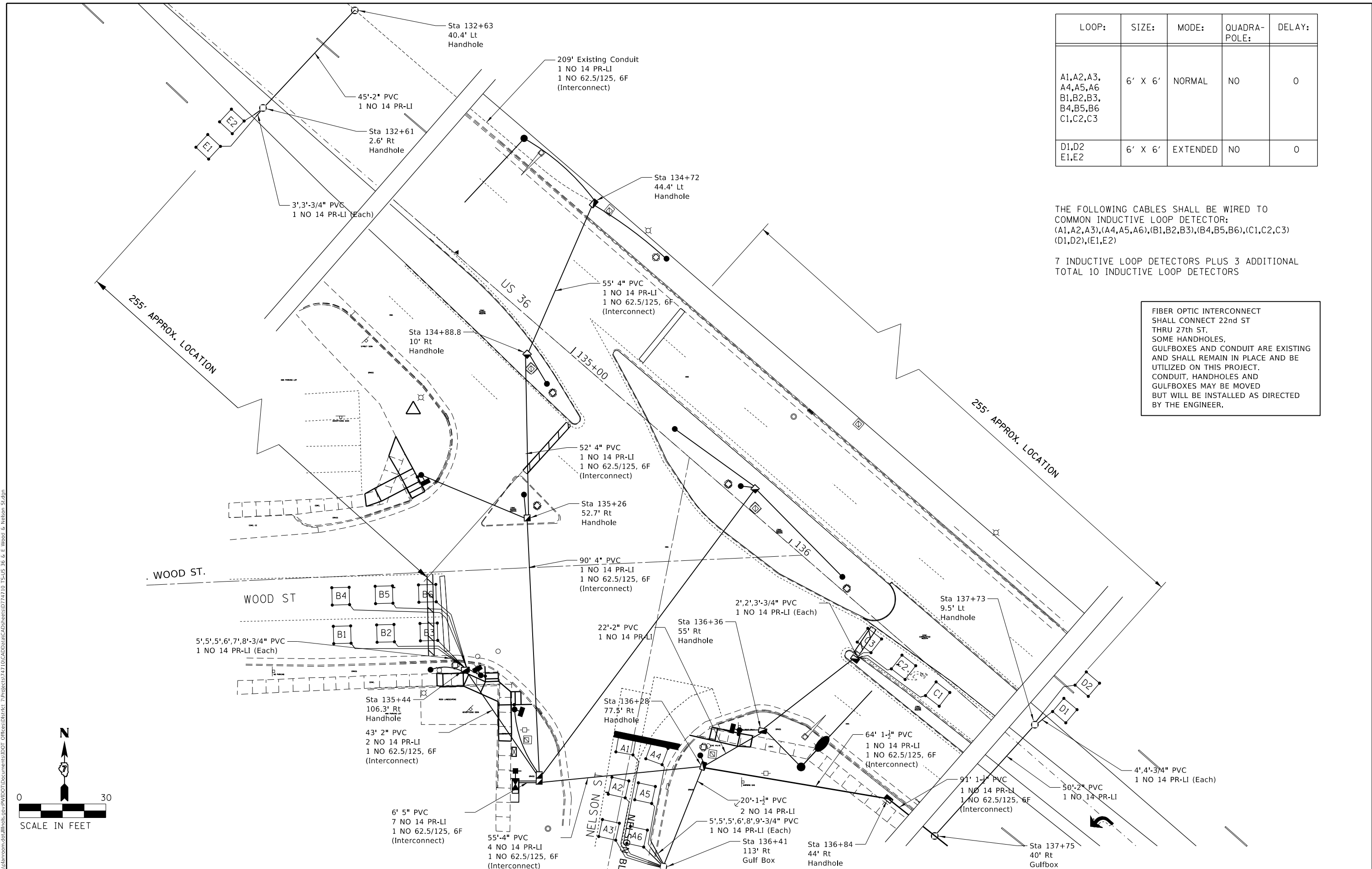

USER NAME = steffemk	DESIGNED -	REVISED -
	DRAWN -	REVISED -
PLOT SCALE = 30.0000 "/td> <td>CHECKED -</td> <td>REVISED -</td>	CHECKED -	REVISED -
PLOT DATE = 2/20/2020	DATE -	REVISED -

**STATE OF ILLINOIS
DEPARTMENT OF TRANSPORTATION**

**INTERSECTION OF US RTE 36 & WOOD & NELSON ST
DETECTOR LOOP**

F.A.P. RTE. 320	SECTION (137z, 139-X-2)RS-2	COUNTY MACON	TOTAL SHEETS 262	SHEET NO. 235
CONTRACT NO. 74710				
ILLINOIS FED. AID PROJECT				

MODEL: Default
FILE: \\nas01c.psu.edu\pub\baronm.d\atllink\pwr\WDDOT\Documents\DOT_Offices\Distct_7\Projects\74710\CADD\Drawings\74710_T54US_36 & E. Wood & Nelson St.dgn

SHEET LEFT BLANK FOR INSERTION OF THE BORING LOGS

FILE NAME =	USER NAME = steffennk	DESIGNED -	REVISED -	STATE OF ILLINOIS DEPARTMENT OF TRANSPORTATION	INTERSECTION (US RTE 36) & NELSON & WOOD ST BORING LOGS	F.A.P. RTE.	SECTION	COUNTY	TOTAL SHEETS	SHEET NO.	
pw:\planroom\dot\illinois.gov\PWIDOT\Documents\DOT Offices\District 7\Projects\74710\CADDData\CADsheets\D774710	Drawn Wood & Nelson S.dgn	CHECKED -	REVISED -			320	(137Z,139-X-2)RS-2	MACON	262	236	
PLOT SCALE = 30,0000' / 1"	DATE -	REVIS	DATE -			CONTRACT NO. 74710					
Default	PLOT DATE = 2/20/2020	REVIS	DATE -			SCALE:	SHEET OF SHEETS	STA. TO STA.	ILLINOIS FED. AID PROJECT		

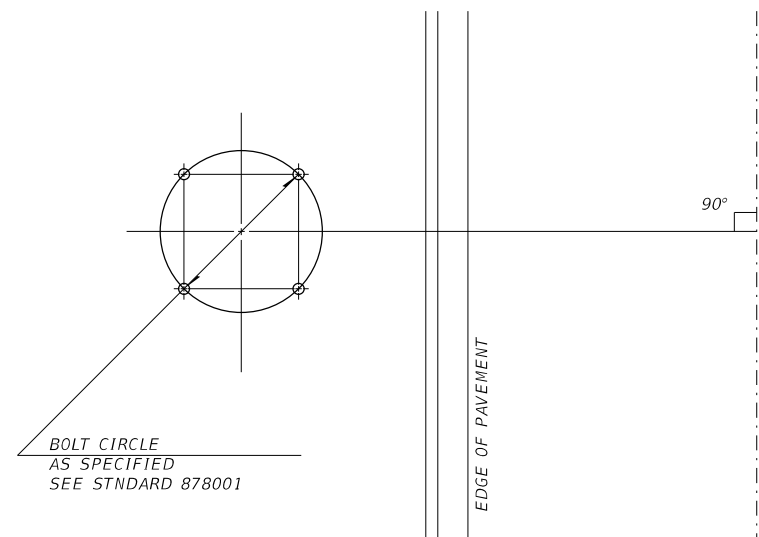

DETAIL OF MAST ARM FOUNDATION
BOLT PATTERN

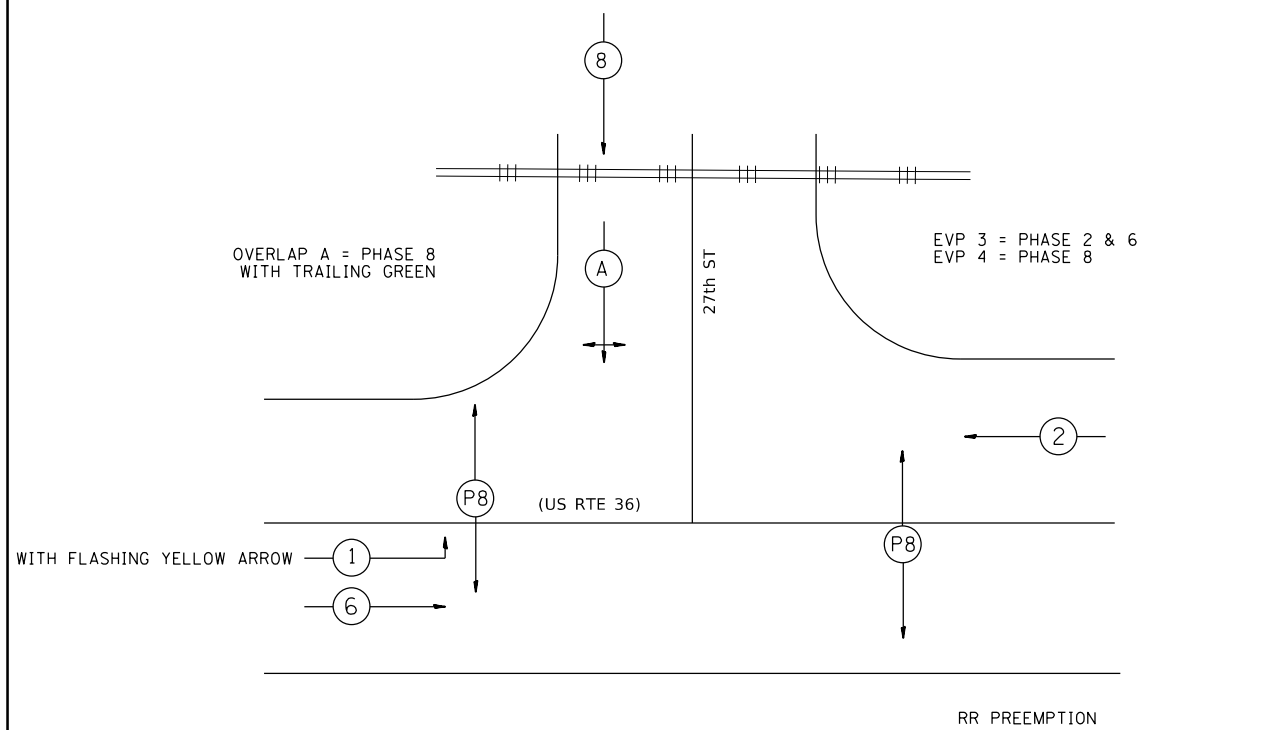

RR PREEMPTION

UPON A DEMAND FOR RR PREEMPTION, ANY ACTIVE NON-TRACK CLEAR INDICATIONS SHALL TERMINATE. PEDESTRIAN CLEARANCE SHALL BE LIMITED TO THROUGH THE ASSOCIATED VEHICULAR YELLOW CLEARANCE INTERVAL ONLY.

TRACK CLEAR = OVERLAP A
DWELL = PHASES 2 & 6

PHASE 1, EBLT SHALL BE RED DURING RAILROAD PREEMPTION

RR PREEMPTION HAS PRIORITY OVER EVP

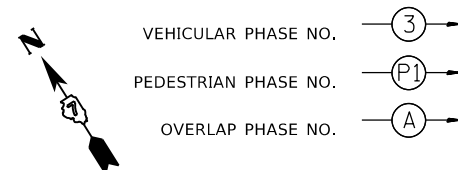

PHASE DESIGNATION DIAGRAM

FILE NAME =	USER NAME = stleffennik	DESIGNED -	REVISED -
pw:\planroom\dot\illinois.gov\PWIDOT\Documents\DOT Offices\District 7\Projects\74710\CADData\CADsheets\ID774710-3-DRAWING\7th St.dgn		DRAWN -	REVISED -
Default	PLOT SCALE = 30,0000' / 1"	CHECKED -	REVISED -
	PLOT DATE = 2/20/2020	DATE -	REVISED -

STATE OF ILLINOIS
DEPARTMENT OF TRANSPORTATION

INTERSECTION OF (US RTE 36) & 27 ST			
DETAILS			
SCALE:	SHEET	OF SHEETS	STA. TO STA.

F.A.P. RTE.	SECTION	COUNTY	TOTAL SHEETS	SHEET NO.
320	(137, 139-X-2)RS-2	MACON	262	237
CONTRACT NO. 74710				
		ILLINOIS	FED. AID PROJECT	

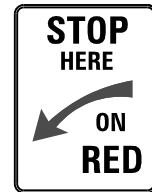

24"x30"
Black on White
MUTCD SIGN DESIGNATION R10-6A

TO INSTALLED ON WB MAST POST (STA 157+13.0, 126.3' LT)

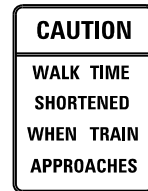

18"x24"
Black on White
ILLINOIS SUPPLEMENT TO THE
MUTCD SIGN DESIGNATION W10-1101

TO INSTALLED ON SIGNAL POST (STA 157+28, 31.6'RT)
TO INSTALLED ON SIGNAL POST (STA 157+89.3, 31.5'RT)
TO INSTALLED ON PED SIGNAL POST (STA 157+36.9, 49' LT)
TO INSTALLED ON PED SIGNAL POST (STA 157+95.5, 77.3' LT)

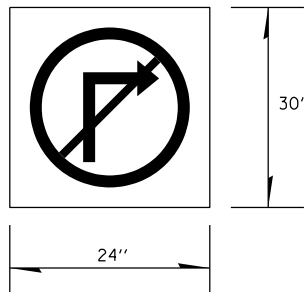

ILLUMINATED SIGN, LED
LED BLANK OUT, RAILROAD PRE-EMPTIVE ACTIVATION
TO INSTALLED ON SIGNAL POST (STA 158+12, 70' LT)
TO INSTALLED ON MAST ARM (STA 156+70, 57.9' LT)

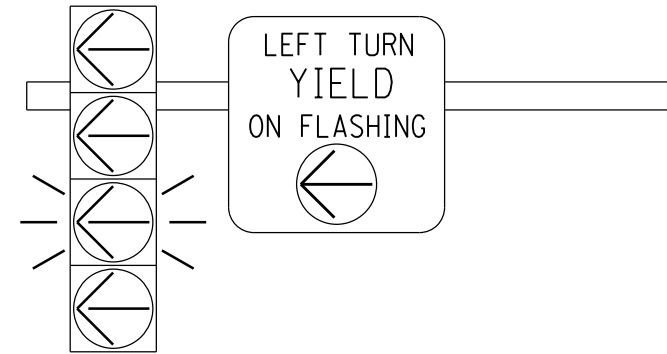

**FLASHING YELLOW ARROW
SIGN PANEL DETAILS**

1. SIGN SHALL HAVE A BLACK REFLECTORIZED LEGEND AND BORDER ON A WHITE REFLECTORIZED BACKGROUND. ARROW IS YELLOW ON A BLACK BACKGROUND.
2. AP SHEETING.
3. SIGN TO BE INSTALLED DIRECTLY ADJACENT TO FYA SIGNAL HEAD ON MAST ARM.
4. ILLINOIS STANDARD R10-1109a SIGN.

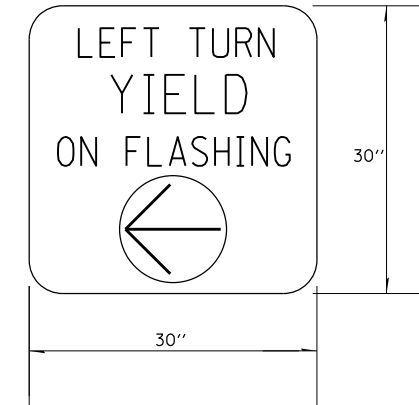

1. SIGN SHALL HAVE A WHITE REFLECTORIZED LEGEND AND BORDER ON A GREEN REFLECTORIZED BACKGROUND.
2. AP SHEETING.
3. UPPER/LOWER CASE LETTERS, HIGHWAY D.

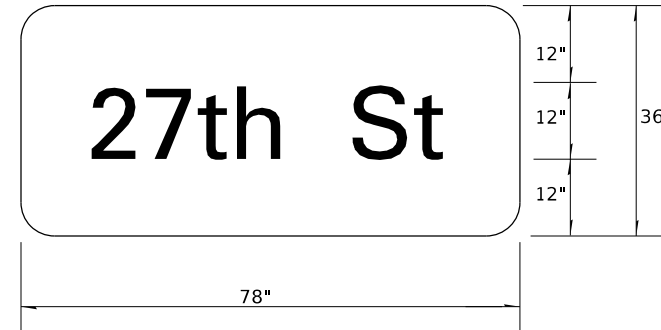

TO INSTALLED ON NB MAST ARM (STA 156+70 57.9' LT)
TO INSTALLED ON SB MAST ARM (STA 158+01' 40.8' RT)

SIGN PANEL DETAILS

MODEL: Default
FILE: \\nas101.pva.uplanet.com\data\illinois.gov\RWIDOT\Documents\DOT_Offices\District_7\Projects\74710\CADData\CAD\Sheet\74710_T5-JUS_36 & 27th_Sig.dgn

USER NAME = steffemk	DESIGNED -
	DRAWN -
PLOT SCALE = 30.0000 ' / in.	CHECKED -
PLOT DATE = 2/20/2020	DATE -

REVISED -
REVISED -
REVISED -
REVISED -

**STATE OF ILLINOIS
DEPARTMENT OF TRANSPORTATION**

**INTERSECTION OF US RTE 36 & 27th ST
SIGN PANNEL DETAILS**

SCALE: SHEET OF SHEETS STA. TO STA.

F.A.P. RTE.	SECTION	COUNTY	TOTAL SHEETS	SHEET NO.
320	(137Z, 139-X-2)RS-2	MACON	262	238
				CONTRACT NO. 74710
ILLINOIS FED. AID PROJECT				

US RTE 36 27th STREET ST-BILL OF MATERIALS

ITEM	UNIT	QUANTITY
SIGN PANEL-TYPE 1	SQ FT	23
SIGN PANEL-TYPE 2	SQ FT	36
SERVICE INSTALLATION, TYPE A	EACH	1
UNDERGROUND CONDUIT, PVC 3/4" DIA.	FOOT	109
UNDERGROUND CONDUIT, PVC 1 1/2" DIA.	FOOT	62
UNDERGROUND CONDUIT, PVC 2" DIA.	FOOT	107
UNDERGROUND CONDUIT, PVC 4" DIA.	FOOT	449
UNDERGROUND CONDUIT, PVC 5" DIA.	FOOT	12
HANDHOLE	EACH	9
DOUBLE HANDHOLE	EACH	1
GULFBOX JUNCTION	EACH	2
MAINTENANCE OF EXISTING TRAFFIC SIGNAL INSTALLATION	EACH	1
RAILROAD FULL-ACTUATED CONTROLLER AND TYPE IV CABINET	EACH	1
UNINTERRUPTABLE POWER SUPPLY, EXTENDED	EACH	1
TRANSCEIVER-FIBER OPTIC	EACH	1
ELECTRIC CABLE IN CONDUIT, SIGNAL NO 14 3C	FOOT	897
ELECTRIC CABLE IN CONDUIT, SIGNAL NO 14 5C	FOOT	2286
ELECTRIC CABLE IN CONDUIT, SIGNAL NO 14 7C	FOOT	781
ELECTRIC CABLE IN CONDUIT, LEAD-IN NO 14 1 PAIR	FOOT	2097
ELECTRIC CABLE IN CONDUIT, RAILROAD, NO 14 3C	FOOT	130
ELECTRIC CABLE IN CONDUIT, SERVICE, NO 6 2C	FOOT	16
ELECTRIC CABLE IN CONDUIT, EQUIPMENT GROUNDING CONDUCTOR, NO 6 1C	FOOT	750
TRAFFIC SIGNAL POST, GALVANIZED STEEL 12 FT	EACH	3
TRAFFIC SIGNAL POST, GALVANIZED STEEL 14 FT	EACH	2
TRAFFIC SIGNAL POST, GALVANIZED STEEL 16 FT	EACH	1
TRAFFIC SIGNAL POST, GALVANIZED STEEL 18 FT	EACH	2
STEEL MAST ARM ASSEMBLY AND POLE, 30 FT	EACH	1
STEEL MAST ARM ASSEMBLY AND POLE, 38 FT	EACH	1
STEEL MAST ARM ASSEMBLY AND POLE, 46 FT	EACH	1
CONCRETE FOUNDATION, TYPE A	FOOT	24
CONCRETE FOUNDATION, TYPE C	FOOT	3.5
CONCRETE FOUNDATION, TYPE E 30-INCH DIAMETER	FOOT	27
CONCRETE FOUNDATION, TYPE E 36-INCH DIAMETER	FOOT	13
DRILL EXISTING HANDHOLE	EACH	1
SIGNAL HEAD, POLYCARBONATE, LED, 1-FACE, 3-SECTION, BRACKET MOUNTED	EACH	2
SIGNAL HEAD, POLYCARBONATE, LED, 1-FACE, 3-SECTION, MAST ARM MOUNTED	EACH	7
SIGNAL HEAD, POLYCARBONATE, LED, 1-FACE, 4-SECTION, BRACKET MOUNTED	EACH	2
SIGNAL HEAD, POLYCARBONATE, LED, 1-FACE, 4-SECTION, MAST ARM MOUNTED	EACH	1
SIGNAL HEAD, POLYCARBONATE, LED, 2-FACE, 3-SECTION, BRACKET MOUNTED	EACH	1
SIGNAL HEAD, POLYCARBONATE, LED, 2-FACE, 1-3-SECTION, 1-4-SECTION BRACKET MOUNTED	EACH	1
PEDESTRIAN SIGNAL HEAD, POLYCARBONATE, LED, 1-FACE, BRACKET MOUNTED	EACH	4
TRAFFIC SIGNAL BACKPLATE, LOUVERED, FORMED PLASTIC	EACH	16
INDUCTIVE LOOP DETECTOR	EACH	10
DETECTOR LOOP, TYPE 1	FOOT	776
PEDESTRIAN PUSH-BUTTON	EACH	4
REMOVE EXISTING SERVICE INSTALLATION	EACH	1
REMOVE EXISTING TRAFFIC SIGNAL EQUIPMENT	EACH	1
REMOVE EXISTING HANDHOLE	EACH	11
REMOVE EXISTING CONCRETE FOUNDATION	EACH	10
SPARE FULL ACTUATED CONTROLLER, SPECIAL	EACH	1

US RTE 36 27th STREET ST-BILL OF MATERIALS

ITEM	UNIT	QUANTITY
ILLUMINATED SIGN, SPECIAL	EACH	2
EMERGENCY VEHICLE PRIORITY SYSTEM	EACH	1

MODEL: Default
 FILE: h:\m\c\p\pub\baron\m.d\illinois\p\p\DOT\Documents\DOT_Offices\Illinet\7\Projects\71710\CADD\DATA\CAD\Sheet\71710_15-US_36 & 27th_Std.dgn

USER NAME = stefenmk	DESIGNED -	REVISED -
PLOT SCALE = 59.9994 ' / in.	CHECKED -	REVISED -
PLOT DATE = 2/20/2020	DATE -	REVISED -

**STATE OF ILLINOIS
DEPARTMENT OF TRANSPORTATION**

**INTERSECTION OF US RTE 36 & 27th ST
BILL OF MATERIALS**

SCALE: SHEET OF SHEETS STA. TO STA.

F.A.P RTE.	SECTION	COUNTY	TOTAL SHEETS	SHEET NO.
320	(137Z, 139-X-2)RS-2	MACON	262	239
				CONTRACT NO. 74710
		ILLINOIS	FED. AID PROJECT	

REMOVAL ITEMS

	Total	NW	NE	SE	SW	Islands
Remove Existing Service Installation	Each 1	-	1	-	-	-
Remove Existing Handhole	Each 11	1	2	2	1	5
Remove Existing Double Handhole	Each -	-	-	-	-	-
Remove Existing Concrete Foundation	Each 10	1	3	3	2	1
Remove Existing Traffic Signal Equipment	Each 1					

▪ See individual items at left below.

THE EXISTING SIGNALS WILL BE MAINTAINED UNTIL THE PROPOSED IS ALL INSTALLED AND OPERATIONAL. THEN THE EXISTING WILL BE REMOVED.

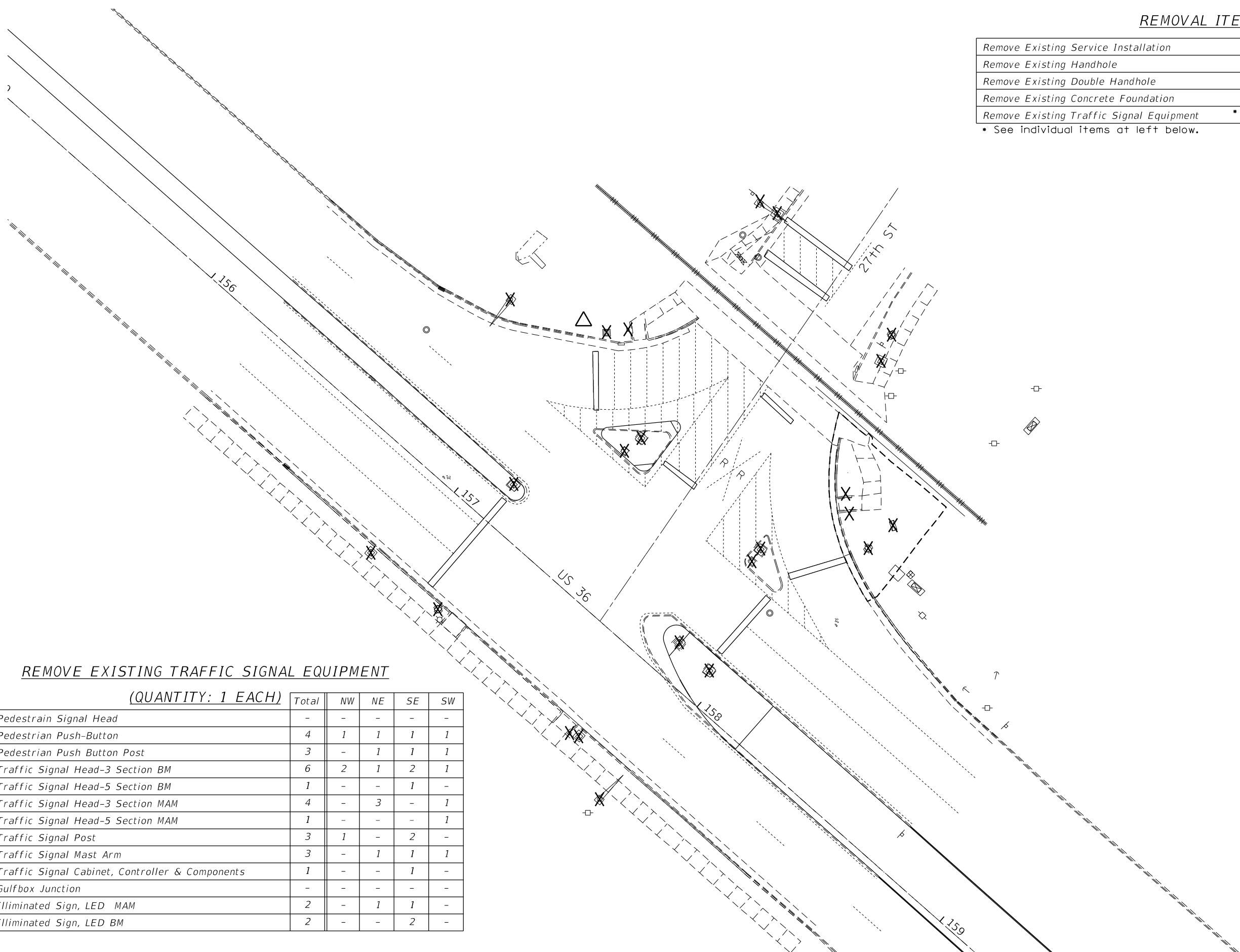

REMOVE EXISTING TRAFFIC SIGNAL EQUIPMENT

(QUANTITY: 1 EACH)

	Total	NW	NE	SE	SW
Pedestrian Signal Head	-	-	-	-	-
Pedestrian Push-Button	4	1	1	1	1
Pedestrian Push Button Post	3	-	1	1	1
Traffic Signal Head-3 Section BM	6	2	1	2	1
Traffic Signal Head-5 Section BM	1	-	-	1	-
Traffic Signal Head-3 Section MAM	4	-	3	-	1
Traffic Signal Head-5 Section MAM	1	-	-	-	1
Traffic Signal Post	3	1	-	2	-
Traffic Signal Mast Arm	3	-	1	1	1
Traffic Signal Cabinet, Controller & Components	1	-	-	1	-
Gulfbox Junction	-	-	-	-	-
Illuminated Sign, LED MAM	2	-	1	1	-
Illuminated Sign, LED BM	2	-	-	2	-

MODEL: Default
FILE: \\nas01\p01\pub\baronm.d\at\illinois.gov\PI\DOT\Documents\DOT_Offices\District_7\Projects\74710\CADD\Drawings\DOT_74710_T54US_36 & 27th_Scdgn

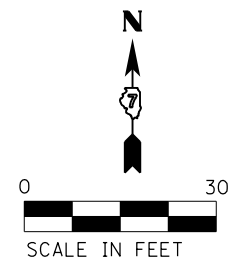

USER NAME = steffemk	DESIGNED -	REVISED -
	DRAWN -	REVISED -
PLOT SCALE = 30.0000 ' / in.	CHECKED -	REVISED -
PLOT DATE = 2/21/2020	DATE -	REVISED -

**STATE OF ILLINOIS
DEPARTMENT OF TRANSPORTATION**

**INTERSECTION OF US RTE 36 & 27th ST
REMOVAL ITEMS**

SCALE: SHEET OF SHEETS STA. TO STA.

F.A.P. RTE.	SECTION	COUNTY	TOTAL SHEETS	SHEET NO.
320	(137z, 139-X-2)RS-2	MACON	262	240
CONTRACT NO. 74710			ILLINOIS FED. AID PROJECT	

MODEL: Default
 FILE: \\nas01c.pw.state.il.us\pub\baronm.d\at\illinois.gov\PI\DOT\Documents\DOT_Offices\District 7\Projects\74710\CADD\Drawings\74710_US36 & 27th_Sig.dgn

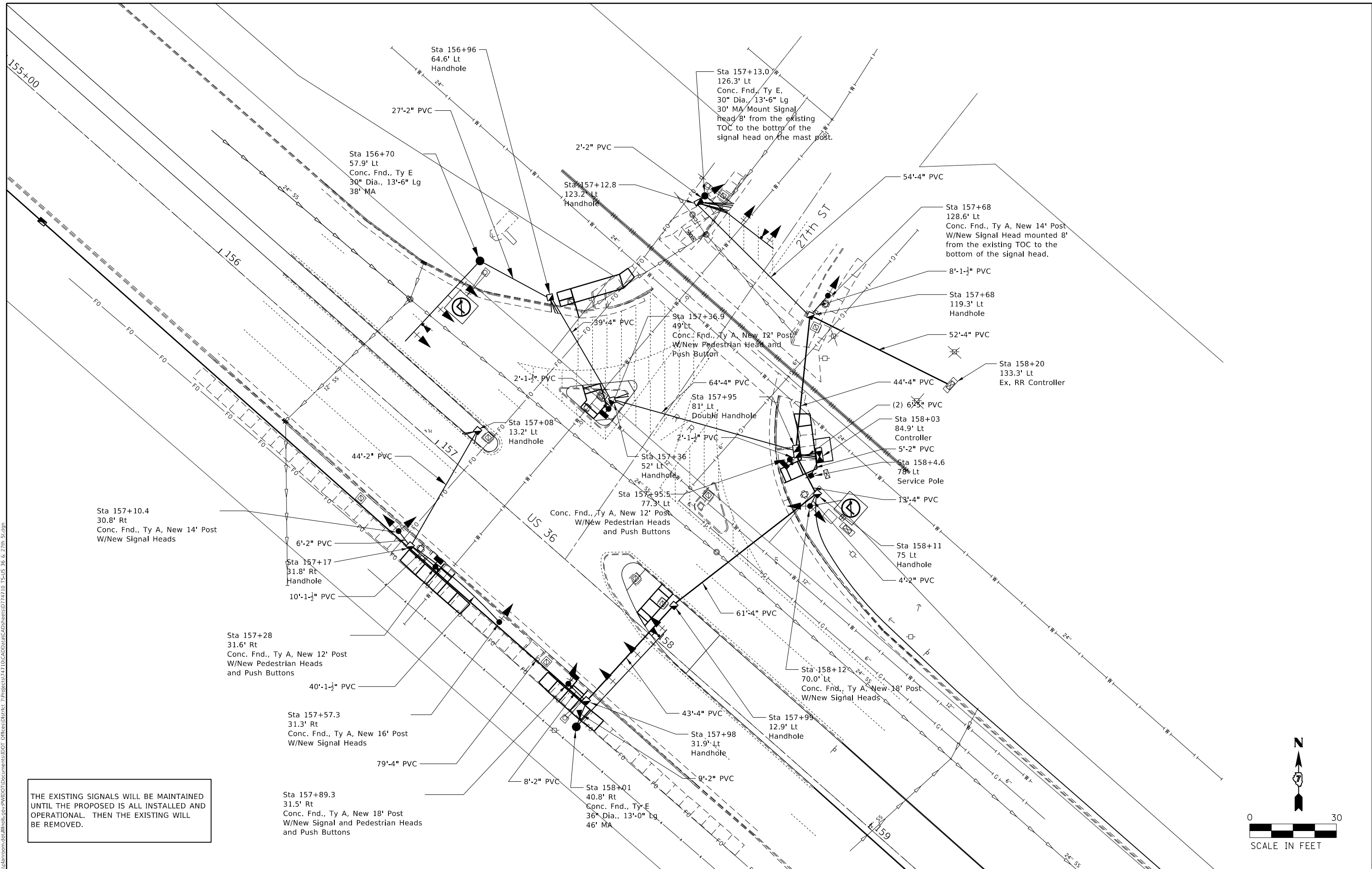

THE EXISTING SIGNALS WILL BE MAINTAINED UNTIL THE PROPOSED IS ALL INSTALLED AND OPERATIONAL. THEN THE EXISTING WILL BE REMOVED.

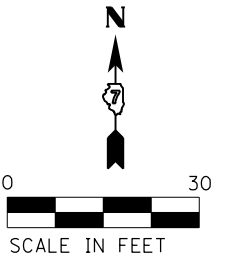

USER NAME = steffemk	DESIGNED -	REVISED -
	DRAWN -	REVISED -
PLOT SCALE = 30.0000' / in.	CHECKED -	REVISED -
PLOT DATE = 2/21/2020	DATE -	REVISED -

**STATE OF ILLINOIS
 DEPARTMENT OF TRANSPORTATION**

INTERSECTION OF US RTE 36 & 27th ST			
SIGNAL LAYOUT			
SCALE:	SHEET	OF SHEETS	STA. TO STA.

F.A.P. RTE.	SECTION	COUNTY	TOTAL SHEETS	SHEET NO.
320	(137z, 139-X-2)RS-2	MACON	262	241
CONTRACT NO. 74710				
ILLINOIS FED. AID PROJECT				

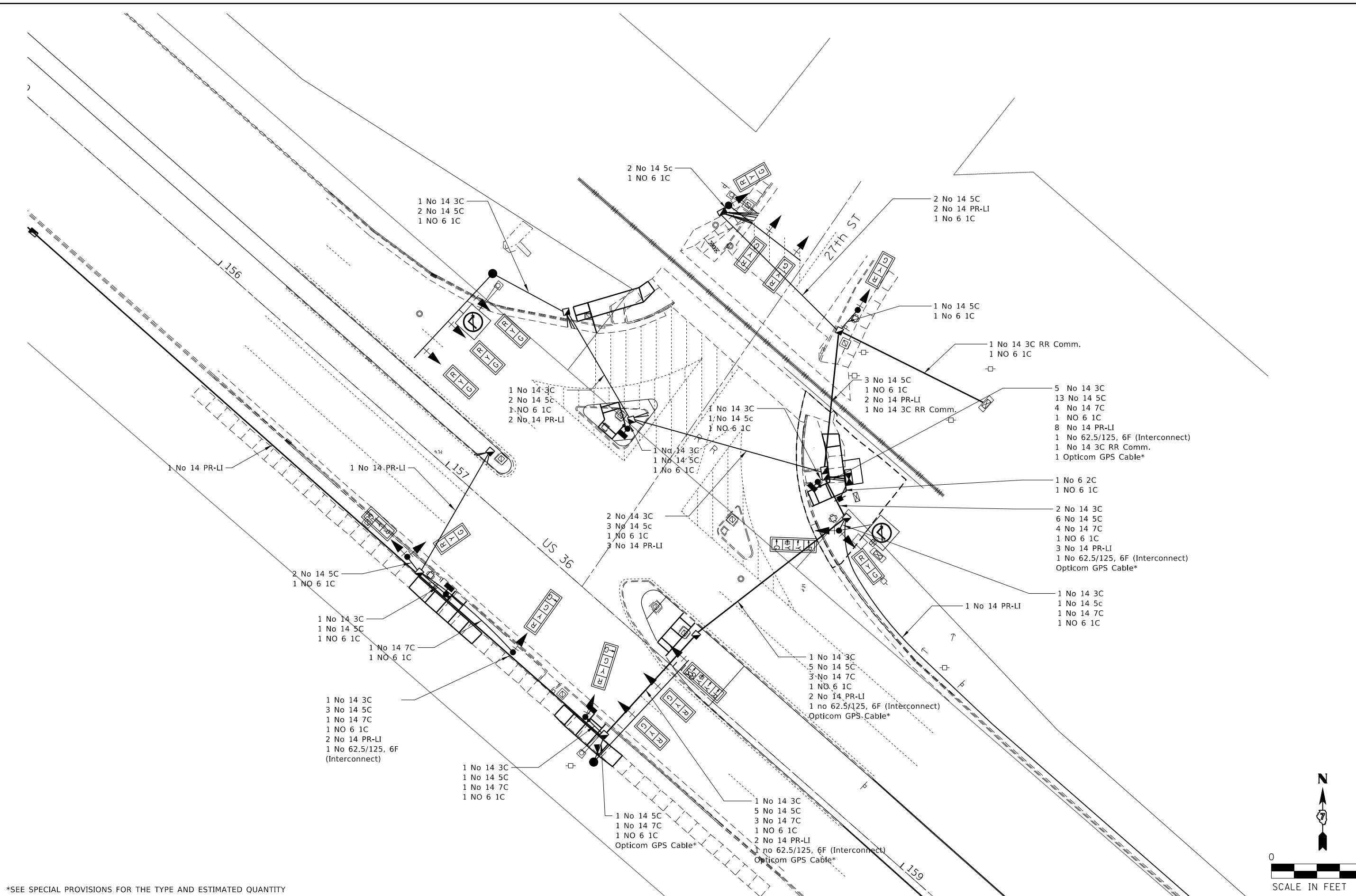

*SEE SPECIAL PROVISIONS FOR THE TYPE AND ESTIMATED QUANTITY

MODEL: Default
 FILE: h:\data\p\pub\harcam\ada\illinois\p\WIDOT\Documents\DOT_Offices\Illinet_7\Projects\71710\CADD\data\CAD\sheets\71710_15-US_36_6_27th_Scdgn

<table border="1"> <tr> <td>USER NAME = steffemk</td> <td>DESIGNED -</td> <td>REVISED -</td> </tr> <tr> <td>PLOT SCALE = 30,0000" / in.</td> <td>DRAWN -</td> <td>REVISED -</td> </tr> <tr> <td>PLOT DATE = 2/21/2020</td> <td>CHECKED -</td> <td>REVISED -</td> </tr> <tr> <td></td> <td>DATE -</td> <td>REVISED -</td> </tr> </table>	USER NAME = steffemk	DESIGNED -	REVISED -	PLOT SCALE = 30,0000" / in.	DRAWN -	REVISED -	PLOT DATE = 2/21/2020	CHECKED -	REVISED -		DATE -	REVISED -	STATE OF ILLINOIS DEPARTMENT OF TRANSPORTATION	INTERSECTION OF US RTE 36 & 27th ST CABLE LAYOUT	<table border="1"> <tr> <td>F.A.P. RTE. 320</td> <td>SECTION (137z, 139-X-2)RS-2</td> <td>COUNTY MACON</td> <td>TOTAL SHEETS 262</td> <td>SHEET NO. 242</td> </tr> <tr> <td colspan="3"></td> <td colspan="2">CONTRACT NO. 74710</td> </tr> <tr> <td colspan="5">ILLINOIS FED. AID PROJECT</td> </tr> </table>	F.A.P. RTE. 320	SECTION (137z, 139-X-2)RS-2	COUNTY MACON	TOTAL SHEETS 262	SHEET NO. 242				CONTRACT NO. 74710		ILLINOIS FED. AID PROJECT				
USER NAME = steffemk	DESIGNED -	REVISED -																												
PLOT SCALE = 30,0000" / in.	DRAWN -	REVISED -																												
PLOT DATE = 2/21/2020	CHECKED -	REVISED -																												
	DATE -	REVISED -																												
F.A.P. RTE. 320	SECTION (137z, 139-X-2)RS-2	COUNTY MACON	TOTAL SHEETS 262	SHEET NO. 242																										
			CONTRACT NO. 74710																											
ILLINOIS FED. AID PROJECT																														
SCALE:		SHEET OF SHEETS	STA. TO STA.																											

SHEET LEFT BLANK FOR INSERTION OF THE BORING LOGS

FILE NAME =	USER NAME = steffennk	DESIGNED -	REVISED -	STATE OF ILLINOIS DEPARTMENT OF TRANSPORTATION	INTERSECTION OF (US RTE 36) & 27 ST BORING LOGS		F.A.P. RTE.	SECTION	COUNTY	TOTAL SHEETS	SHEET NO.
pw:\planroom\dot\illinois.gov\PWIDOT\Documents\IDOT\Offices\District 7\Projects\74710\CADDData\CADsheets\ID74710	DESIGNED -	REVISED -	320				(137, 139-X-2)RS-2	MACON	262	244	
PLOT SCALE = 30,0000' / in.	CHECKED -	REVISED -	CONTRACT NO. 74710								
Default	PLOT DATE = 2/20/2020	DATE -	REVISED -		SCALE:	SHEET OF SHEETS	STA. TO STA.	ILLINOIS	FED. AID PROJECT		

MODEL: Default
 FILE: h:\mhc\p\pub\haronom.dwg
 PROJECT: 74710\CAAD\DATA\CAD\harses\74710_15_US_36_6_44th_S.dgn

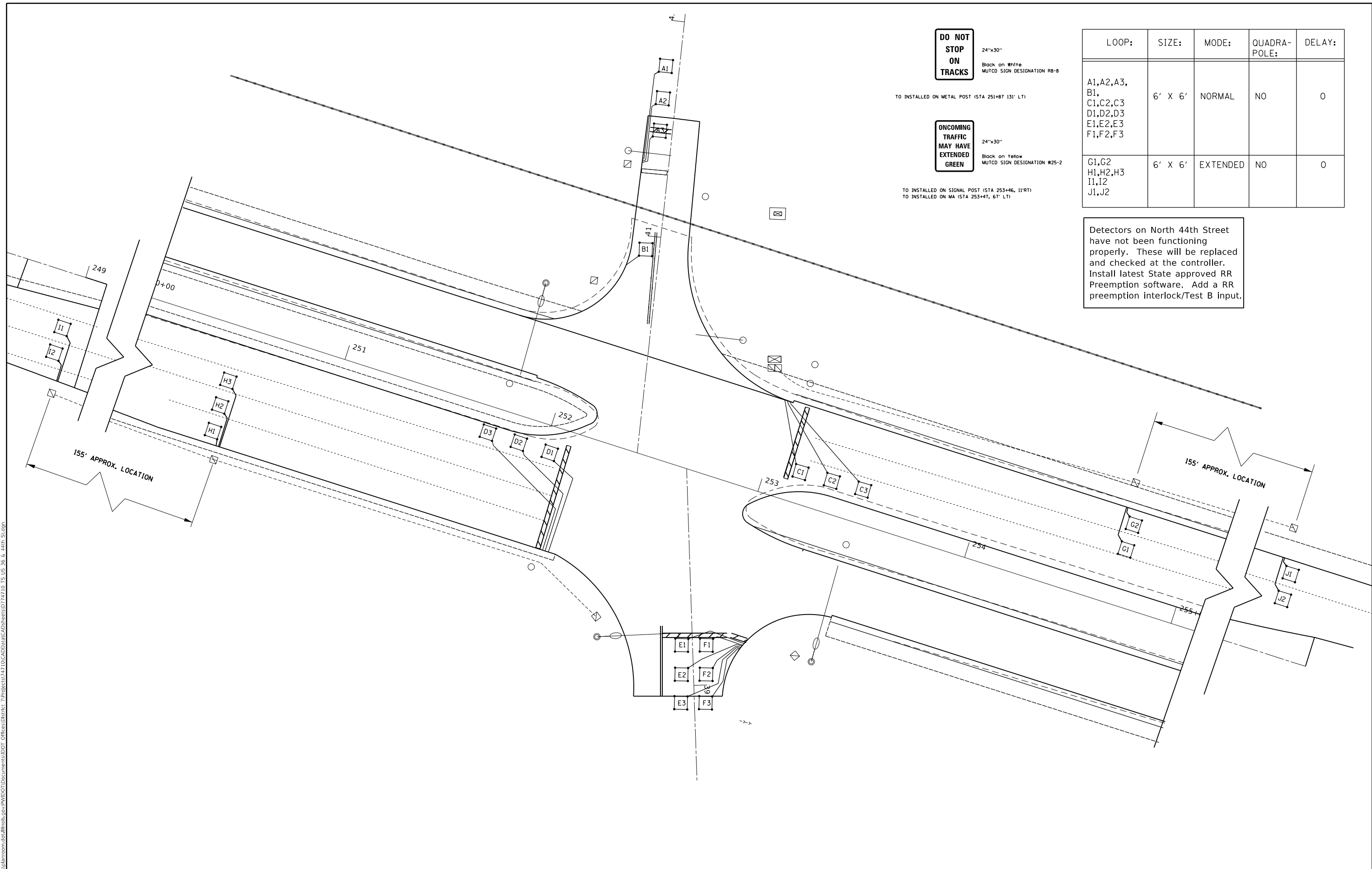

DO NOT STOP ON TRACKS

24"x30"
 Black on White
 MUTCD SIGN DESIGNATION R8-8

TO INSTALLED ON METAL POST (STA 251+87 131' LT)

ONCOMING TRAFFIC MAY HAVE EXTENDED GREEN

24"x30"
 Black on Yellow
 MUTCD SIGN DESIGNATION W25-2

TO INSTALLED ON SIGNAL POST (STA 253+46, 11'RT)
 TO INSTALLED ON MA (STA 253+47, 67' LT)

LOOP:	SIZE:	MODE:	QUADRA-POLE:	DELAY:
A1,A2,A3, B1, C1,C2,C3 D1,D2,D3 E1,E2,E3 F1,F2,F3	6' X 6'	NORMAL	NO	0
G1,G2 H1,H2,H3 I1,I2 J1,J2	6' X 6'	EXTENDED	NO	0

Detectors on North 44th Street have not been functioning properly. These will be replaced and checked at the controller. Install latest State approved RR Preemption software. Add a RR preemption interlock/Test B input.

USER NAME = steffenmk	DESIGNED -	REVISED -
PLOT SCALE = 40.0000 ' / in.	DRAWN -	REVISED -
PLOT DATE = 2/21/2020	CHECKED -	REVISED -
	DATE -	REVISED -

**STATE OF ILLINOIS
 DEPARTMENT OF TRANSPORTATION**

**INTERSECTION OF US RTE 36 & 44th ST
 DETECTOR LOOP**

SCALE: SHEET OF SHEETS STA. TO STA.

F.A.P. RTE.	SECTION	COUNTY	TOTAL SHEETS	SHEET NO.
320	(137z, 139-X-2)RS-2	MACON	262	245
CONTRACT NO. 74710				
ILLINOIS FED. AID PROJECT				

MODEL: Default
 FILE: h:\a\c\p\pub\baronm.dwg
 PLOT DATE: 2/20/2020
 PROJECT: 71710\CADD\DATA\CAD\Drawings\DOT\Office\Detail\71710-SHT-LOOP-DETAILS.dwg

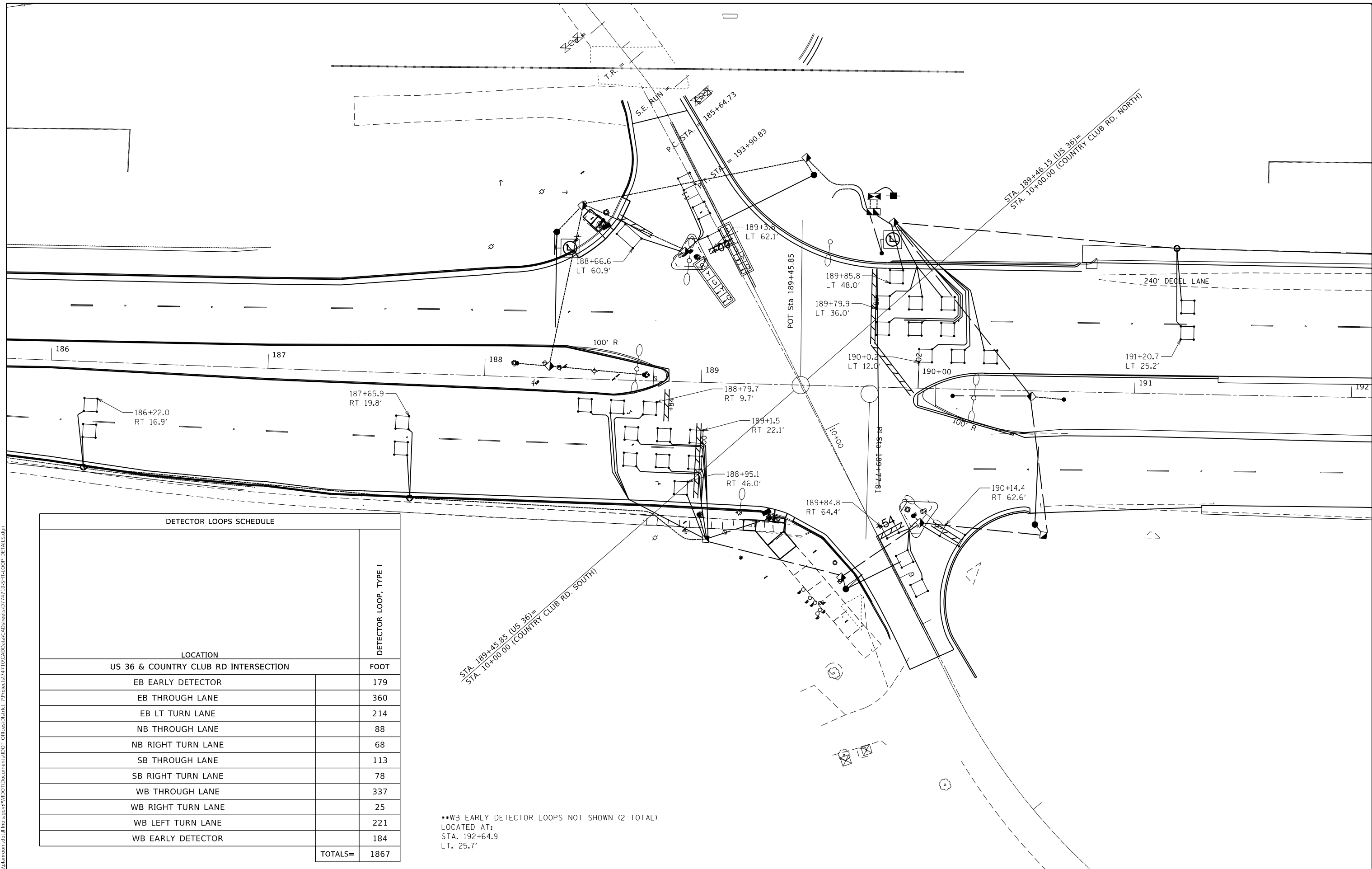

DETECTOR LOOPS SCHEDULE

LOCATION	DETECTOR LOOP, TYPE I
US 36 & COUNTRY CLUB RD INTERSECTION	FOOT
EB EARLY DETECTOR	179
EB THROUGH LANE	360
EB LT TURN LANE	214
NB THROUGH LANE	88
NB RIGHT TURN LANE	68
SB THROUGH LANE	113
SB RIGHT TURN LANE	78
WB THROUGH LANE	337
WB RIGHT TURN LANE	25
WB LEFT TURN LANE	221
WB EARLY DETECTOR	184
TOTALS=	1867

••WB EARLY DETECTOR LOOPS NOT SHOWN (2 TOTAL)
 LOCATED AT:
 STA. 192+64.9
 LT. 25.7'

STATE OF ILLINOIS
DEPARTMENT OF TRANSPORTATION

DETECTOR LOOP
DETAILS

SCALE: SHEET 1 OF 4 SHEETS STA. TO STA.

F.A.P. RTE.	SECTION	COUNTY	TOTAL SHEETS	SHEET NO.
*	(137Z, 139-X-2) R5-2	MACON	262	246
* F.A.P. RTE 320, 323, 323A		CONTRACT NO. 74710		
ILLINOIS FED. AID PROJECT				

MODEL: Default
 FILE: h:\m\c\p\pub\barroom.dwg
 PROJECT: 171710\CADD\DATA\CAD\sheet\171710-SHT-LOOP-DETAILS.dwg

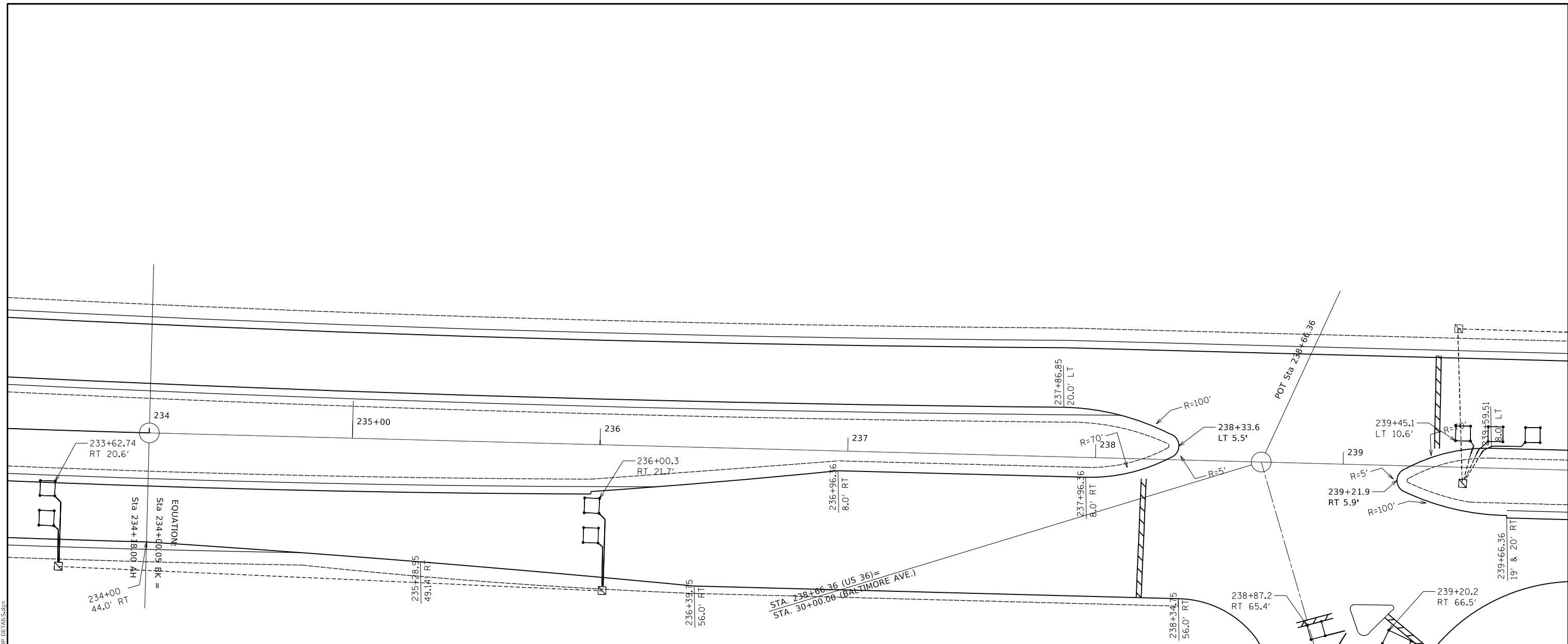

DETECTOR LOOPS SCHEDULE		DETECTOR LOOP, TYPE I
LOCATION		
US 36 & BALTIMORE ST. STREET INTERSECTION		FOOT
EB EARLY DETECTOR		182
NB LANE		68
NB RIGHT TURN LANE		87
WB LEFT TURN LANE		105
** WB EARLY DETECTOR		177
TOTALS=		619

**WB EARLY DETECTOR LOOPS NOT SHOWN (4 TOTAL)
 LOCATED AT:
 STA. 241+63.4 STA. 243+83.7
 LT. 23.0' LT. 22.0'

USER NAME = steffenmk	DESIGNED -	REVISED -
PLOT SCALE = 40.0000' / in.	DRAWN -	REVISED -
PLOT DATE = 2/20/2020	CHECKED -	REVISED -
	DATE -	REVISED -

**STATE OF ILLINOIS
 DEPARTMENT OF TRANSPORTATION**

DETECTOR LOOP DETAILS			
SCALE:	SHEET 2	OF 4 SHEETS	STA. TO STA.

F.A.P. RTE.	SECTION	COUNTY	TOTAL SHEETS	SHEET NO.
*	(137Z, 139-X-2) R5-2	MACON	262	247
CONTRACT NO. 74710				
ILLINOIS FED. AID PROJECT				

DETECTOR LOOPS SCHEDULE		DETECTOR LOOP, TYPE I
LOCATION		
US 36 & 44TH STREET INTERSECTION		FOOT
EB EARLY DETECTOR		80
EB THROUGH LANE		124
EB LT TURN LANE		259
NB THROUGH LANE		357
SB THROUGH LANE		178
WB LEFT TURN LANE		206
WB EARLY DETECTOR		155
TOTALS=		1359

••EB EARLY DETECTOR LOOPS NOT SHOWN (2 TOTAL)
 LOCATED AT:
 STA. 248+99.9
 RT. 22.5'

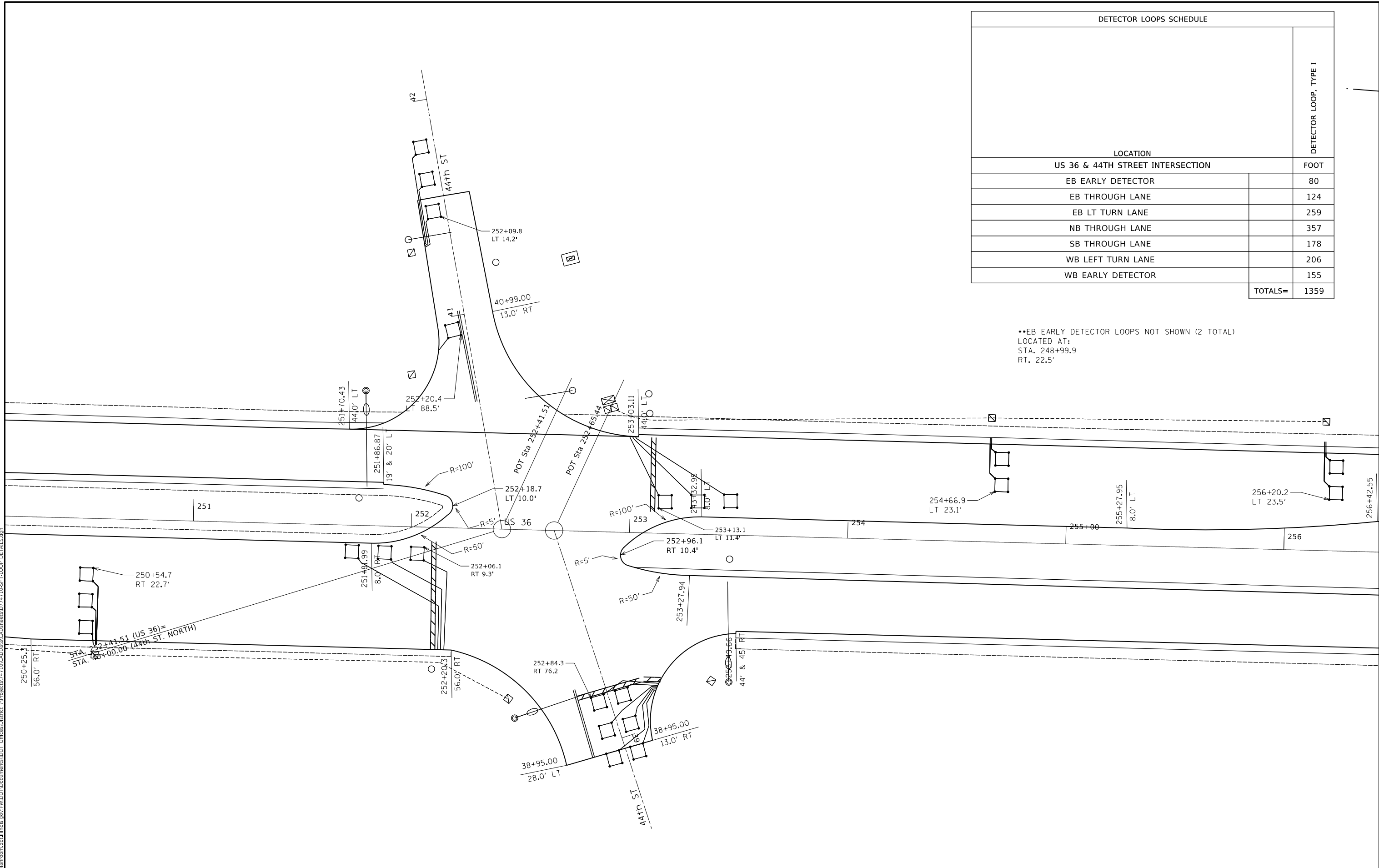

MODEL: Default
 FILE: h:\bldg\p\pub\arcom\dat\illinois.gov\PIWDOT\Documents\DOT_Offices\Illinet\7\Projects\74710\CADD\Drawings\74710-SITE-LOOP-DETAILS.dwg
 PROJECT: 74710\CADD\Drawings\74710-SITE-LOOP-DETAILS.dwg
 DATE: 2/20/2020

USER NAME = steffenmk	DESIGNED -	REVISED -
	DRAWN -	REVISED -
PLOT SCALE = 40.0000 "/td> <td>CHECKED -</td> <td>REVISED -</td>	CHECKED -	REVISED -
PLOT DATE = 2/20/2020	DATE -	REVISED -

STATE OF ILLINOIS
DEPARTMENT OF TRANSPORTATION

DETECTOR LOOP
DETAILS

SCALE: SHEET 3 OF 4 SHEETS STA. TO STA.

F.A.P. RTE.	SECTION	COUNTY	TOTAL SHEETS	SHEET NO.
	(137Z, 139-X-2) R5-2	MACON	262	248
CONTRACT NO. 74710				
		ILLINOIS	FED. AID PROJECT	

DETECTOR LOOPS SCHEDULE			
LOCATION	DETECTOR LOOP, TYPE I	LOCATION	DETECTOR LOOP, TYPE I
US 36 & AIRPORT RD INTERSECTION	FOOT	SB RT TURN LANE	130
EB EARLY DETECTOR	120	SB THROUGH LANE	120
EB THROUGH LANE	241	SB LT TURN LANE	236
EB LT TURN LANE	134	SB RR PRE-SIGNAL LANE	198
NB THROUGH LANE	119	WB LT TURN LANE	113
NB RT TURN LANE	123	WB EARLY DETECTOR	168
NB LT TURN LANE	288	WB EARLY DETECTOR	168
		SB EARLY DETECTOR ON MARYLAND	127
TOTALS=			2285

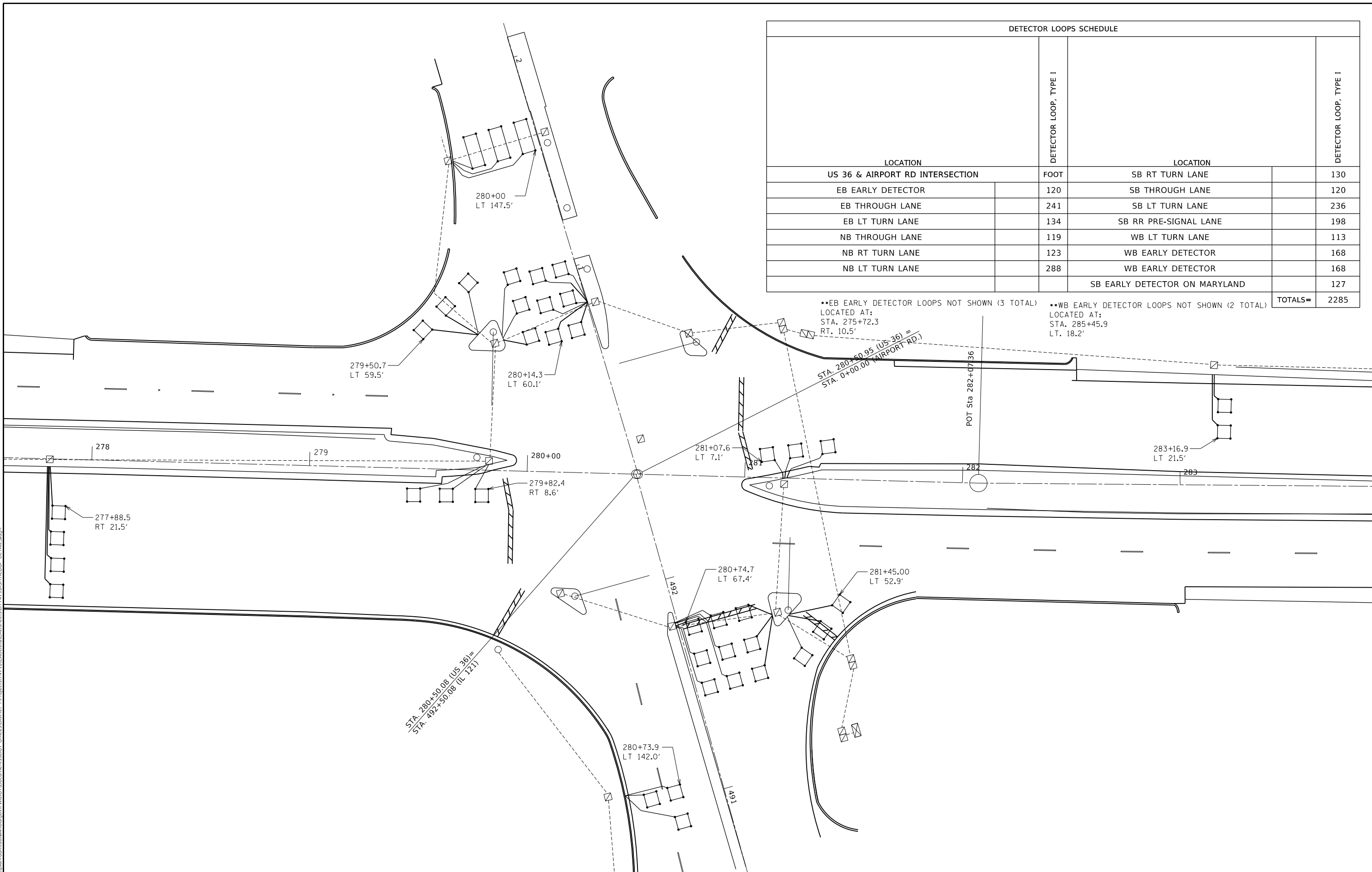

MODEL: Default
 FILE: h:\a\c\p\pub\harcam.dwg
 PROJECT: 74710\CADD\Drawings\DOT_Offices\Detail\74710-SHT-LOOP_DETAILS.dwg

USER NAME = steffemk	DESIGNED -	REVISED -
PLOT SCALE = 40.0000 ' / in.	DRAWN -	REVISED -
PLOT DATE = 2/20/2020	CHECKED -	REVISED -
	DATE -	REVISED -

STATE OF ILLINOIS
DEPARTMENT OF TRANSPORTATION

DETECTOR LOOP
DETAILS

SCALE: SHEET 4 OF 4 SHEETS STA. TO STA.

F.A.P. RTE.	SECTION	COUNTY	TOTAL SHEETS	SHEET NO.
	(137Z, 139-X-2) R5-2	MACON	262	249
CONTRACT NO. 74710				
ILLINOIS FED. AID PROJECT				

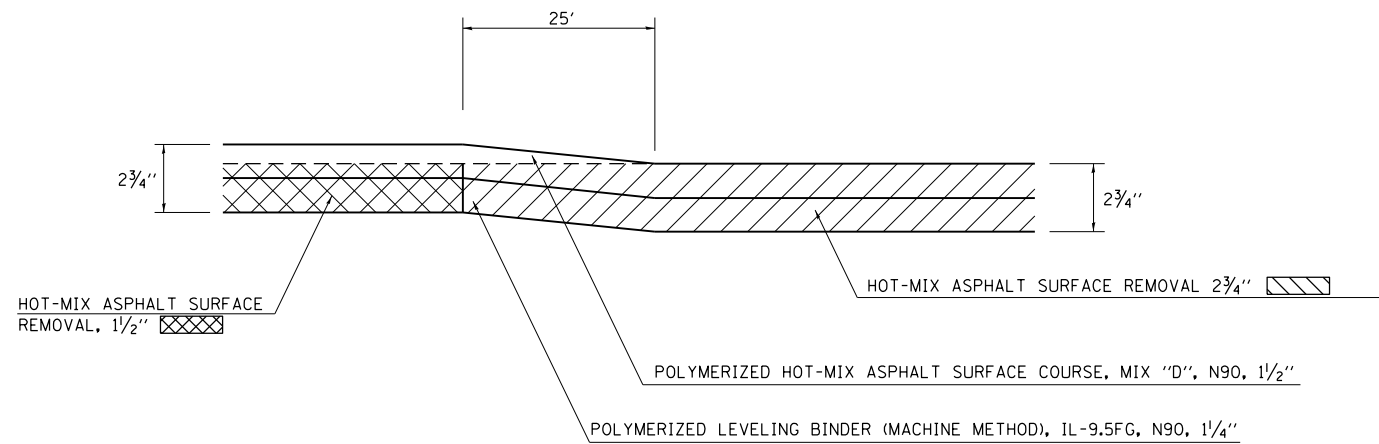

MILLING TRANSITION DETAIL
 STA. 277+65.3 TO STA. 277+90.3

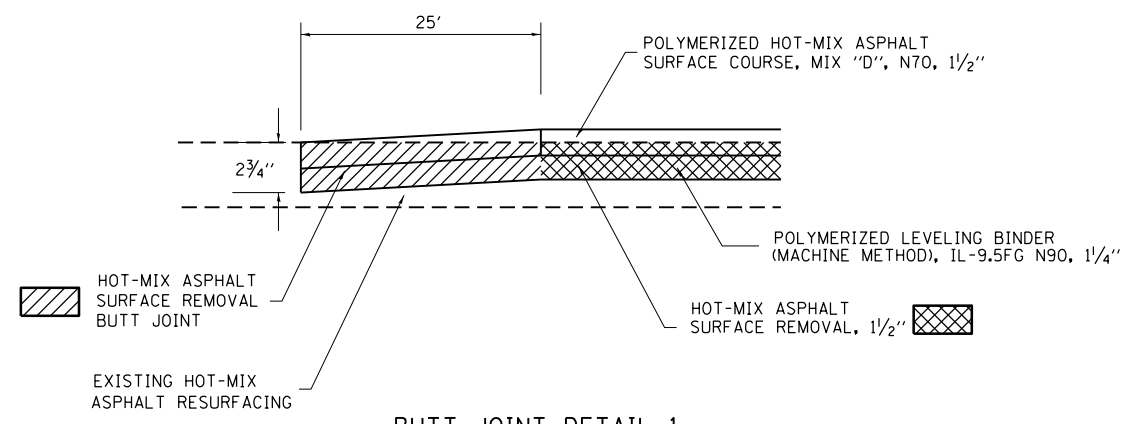

BUTT JOINT DETAIL 1
 STA. 190+65.62 TO STA. 190+90.62
 STA. 283+02.7 TO STA. 283+27.7

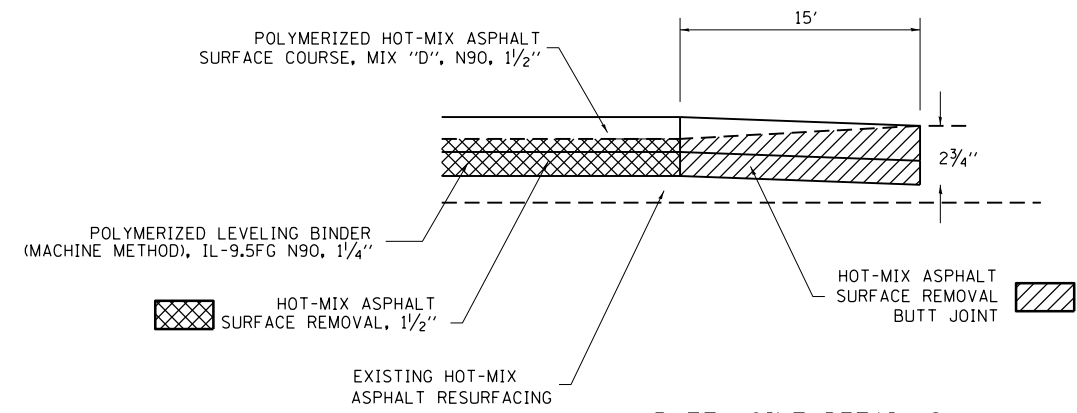

BUTT JOINT DETAIL 2

MODEL: Default
 FILE: h:\mhc\p\pub\harcross.dwg
 PROJECT: 74710\CAD\DATA\CAD\DETAILS\74710-5-HC-DETAILS.dwg

USER NAME = steffemk	DESIGNED -	REVISED -
	DRAWN -	REVISED -
PLOT SCALE = 100.0000' / in.	CHECKED -	REVISED -
PLOT DATE = 2/20/2020	DATE -	REVISED -

**STATE OF ILLINOIS
 DEPARTMENT OF TRANSPORTATION**

**SURFACE REMOVAL
 DETAILS**

SCALE: SHEET 1 OF 1 SHEETS STA. TO STA.

F.A.P. RTE.	SECTION	COUNTY	TOTAL SHEETS	SHEET NO.
*	(137Z, 139-X-2)RS-2	MACON	262	250
*F.A.P. RTE. 320, 323, 323A			CONTRACT NO. 74710	
ILLINOIS FED. AID PROJECT				

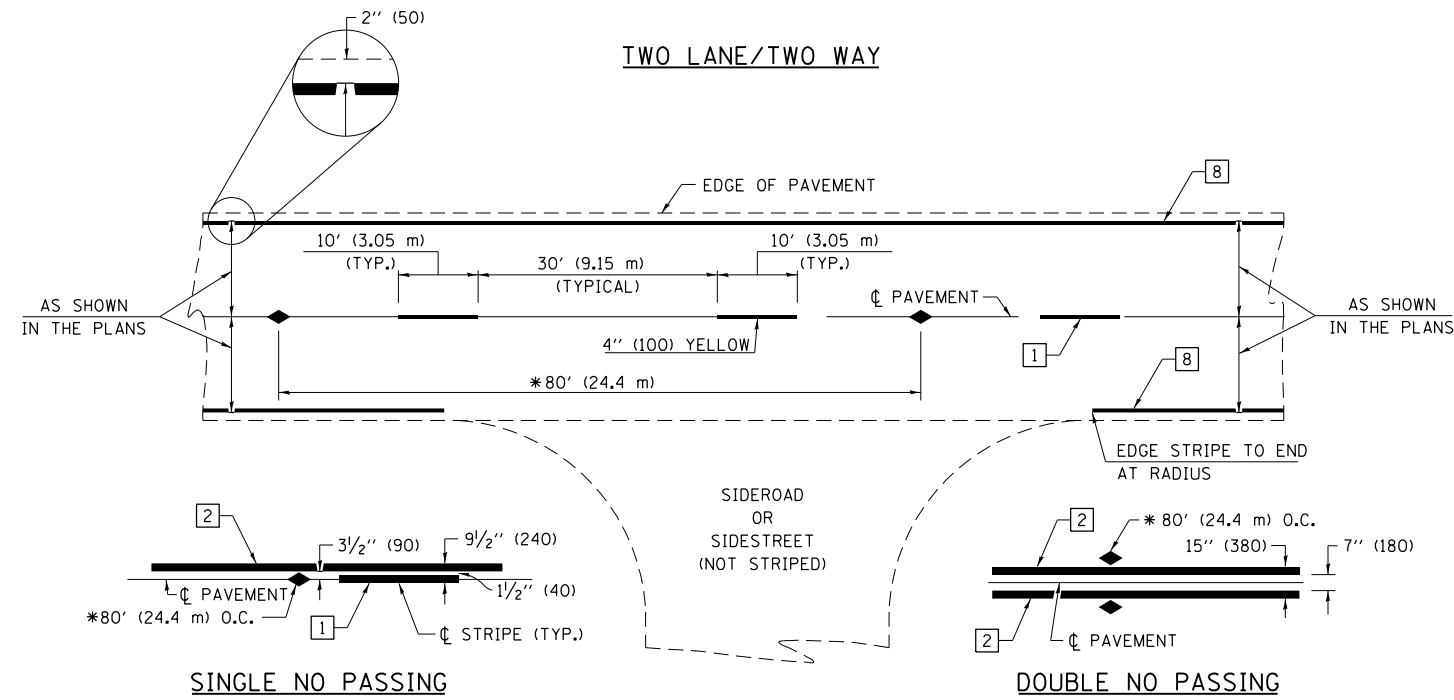

* REDUCE TO 40' (12.2 m) O.C. ON CURVES WITH POSTED OR ADVISORY SPEEDS OF 45 mph (70 km/h) OR LESS.

PAVEMENT MARKING LEGEND

- 1 4" (100) SKIP-DASH (YELLOW)
 - 2 4" (100) SOLID (YELLOW)
 - 3 12" (300) DIAGONAL (YELLOW)
 - 4 4" (100) DOUBLE YELLOW (NARROW)
 - 5 12" (300) SOLID WHITE
 - 6 RESERVED
 - 7 6" (150) SKIP-DASH (WHITE)
 - 8 4" (100) SOLID (WHITE)
 - 9 12" (300) DIAGONAL (WHITE)
 - 10 6" (150) SOLID (WHITE)
 - 11 24" (600) STOP BAR (WHITE)
 - 12 8" (200) SOLID (WHITE)
 - 13 4" (100) PARKING WHITE
-

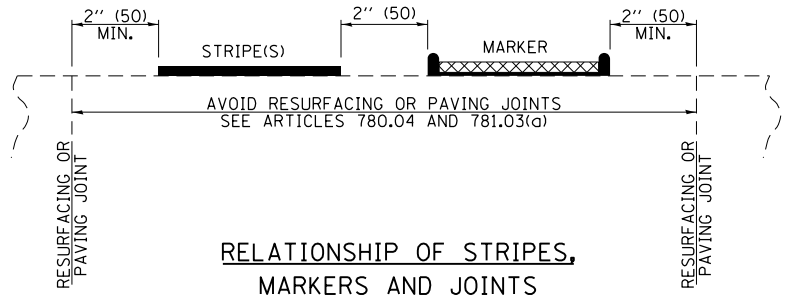

TYPICAL PAVEMENT MARKERS LEGEND

- ◆ TWO-WAY AMBER MARKER
- ▶ ONE-WAY AMBER MARKER
- ▷ ONE-WAY CRYSTAL MARKER

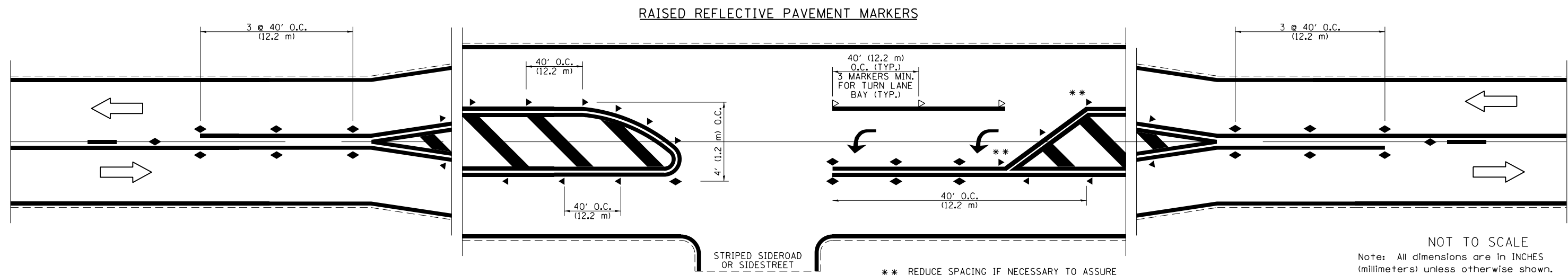

NOT TO SCALE
Note: All dimensions are in INCHES (millimeters) unless otherwise shown.

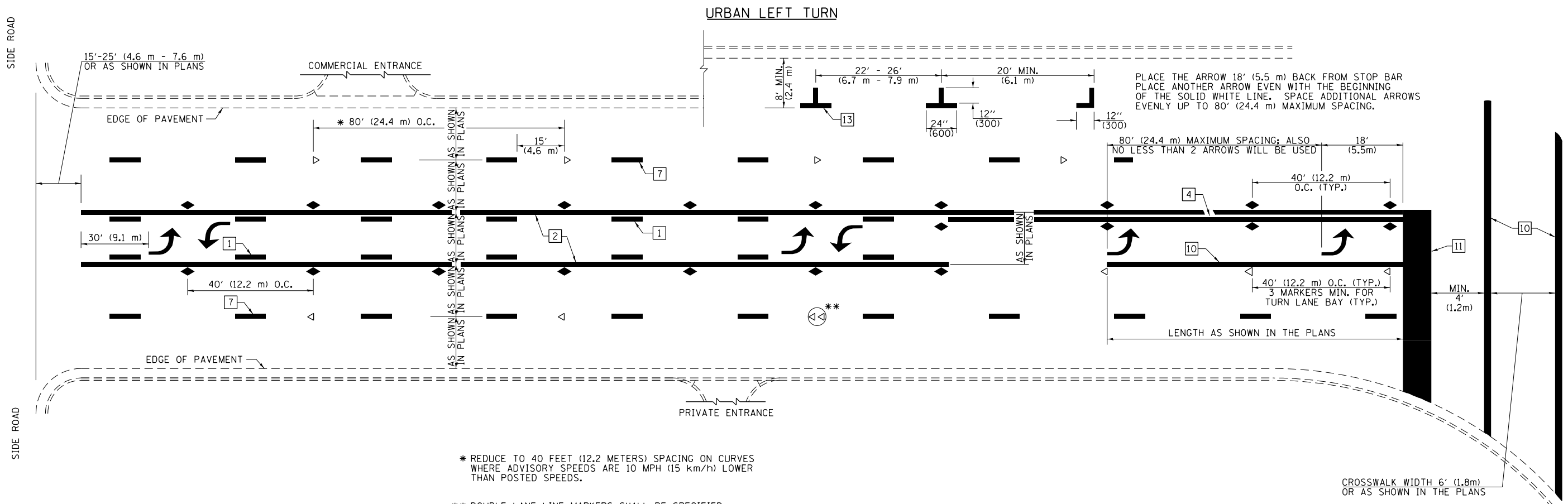

- * REDUCE TO 40 FEET (12.2 METERS) SPACING ON CURVES WHERE ADVISORY SPEEDS ARE 10 MPH (15 km/h) LOWER THAN POSTED SPEEDS.
- ** DOUBLE LANE LINE MARKERS SHALL BE SPECIFIED AND SPACED AS SHOWN IN HIGHWAY STANDARD 781001 FOR MULTI-LANE DIVIDED AND UNDIVIDED HIGHWAYS.

PAVEMENT MARKING LEGEND

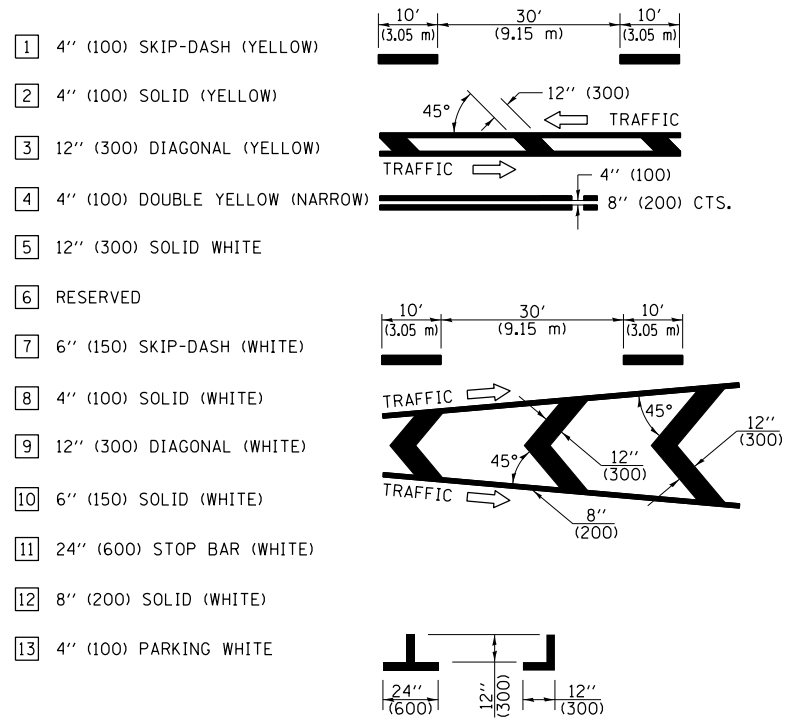

GENERAL NOTES

1. TURN ARROW PAIRS SHALL BE PLACED AT 250' (75 m) INTERVALS AND SHALL BE EVENLY SPACED BETWEEN BOTH ENDS OF THE BIDIRECTIONAL LEFT TURN LANE. USE A MINIMUM OF TWO PAIRS PER BLOCK.
2. THE SOLID YELLOW PAVEMENT MARKINGS [2] SHOULD GENERALLY START OR END NEAR THE RADIUS POINT OF EACH STREET RETURN EXCEPT WHERE ONE OR BOTH ENDS WOULD INCLUDE STOP BARS.
3. THE SKIP-DASH PAVEMENT MARKINGS [1] OR [7] SHOULD BE CENTERED BETWEEN BOTH ENDS OF EACH CITY BLOCK AND SHALL BE PLACED SO THEY LINE UP ACROSS FROM EACH OTHER.
4. USE LARGE ARROW SIZE FOR BOTH RURAL AND URBAN LOCATIONS. (SEE LAST PAGE OF SECTION 780x FOR SYMBOLS TABLE)
5. LANE LINE EXTENSIONS SHALL BE THE SAME COLOR AND WIDTH AS THE LANE LINE BEING EXTENDED.

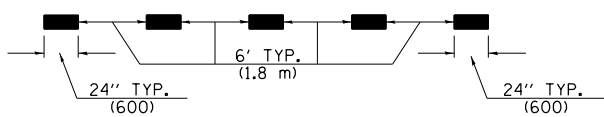

LANE LINE EXTENSIONS

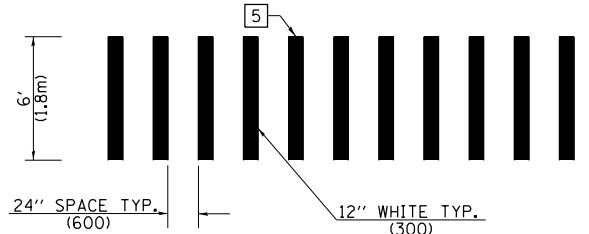

CROSSWALK DETAIL (DECATUR CITY LIMITS ONLY)

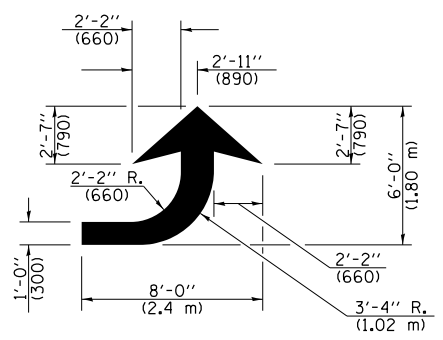

LEFT ARROW

REVERSE FOR RIGHT ARROW
AREA = 15.6 SQ. FT. (1.47 m²)
(WHITE)

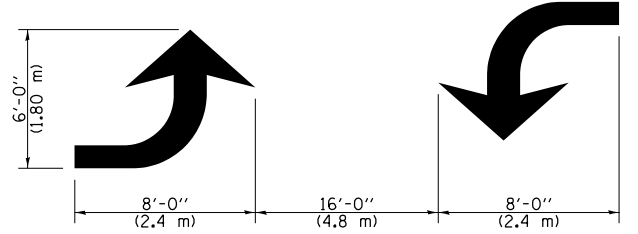

TYPICAL DOUBLE TURN ARROWS (WHITE)

NOT TO SCALE

Note: All dimensions are in INCHES (millimeters) unless otherwise shown.

FILE NAME =	USER NAME = steffennk	DESIGNED -	REVISED -	STATE OF ILLINOIS DEPARTMENT OF TRANSPORTATION	PAVEMENT MARKING AND RAISED REFLECTIVE PAVEMENT MARKERS (RURAL & URBAN APPLICATIONS)	F.A.P. RTE.	SECTION	COUNTY	TOTAL SHEETS	SHEET NO.
pw:\planroom.dot.illinois.gov\PIDOT\Documents\IDOT Offices\District 7\Projects\74710\CAD\CADsheets\0774710-sht-DETAILS.dwg	CBROWN	REVISIONS	REVISIONS			* (137Z, 139-X-2)RS-2	MACON	262	252	
		CHECKED -	REVISIONS -			*F.A.P. RTE. 320, 323, 323A	CONTRACT NO. 74710			
		DATE -	REVISIONS -			ILLINOIS FED. AID PROJECT				
	PLOT SCALE = 80.0000' / in.			SCALE:	SHEET NO. 2 OF 4 SHEETS	STA.	TO STA.			
	PLOT DATE = 2/20/2020									

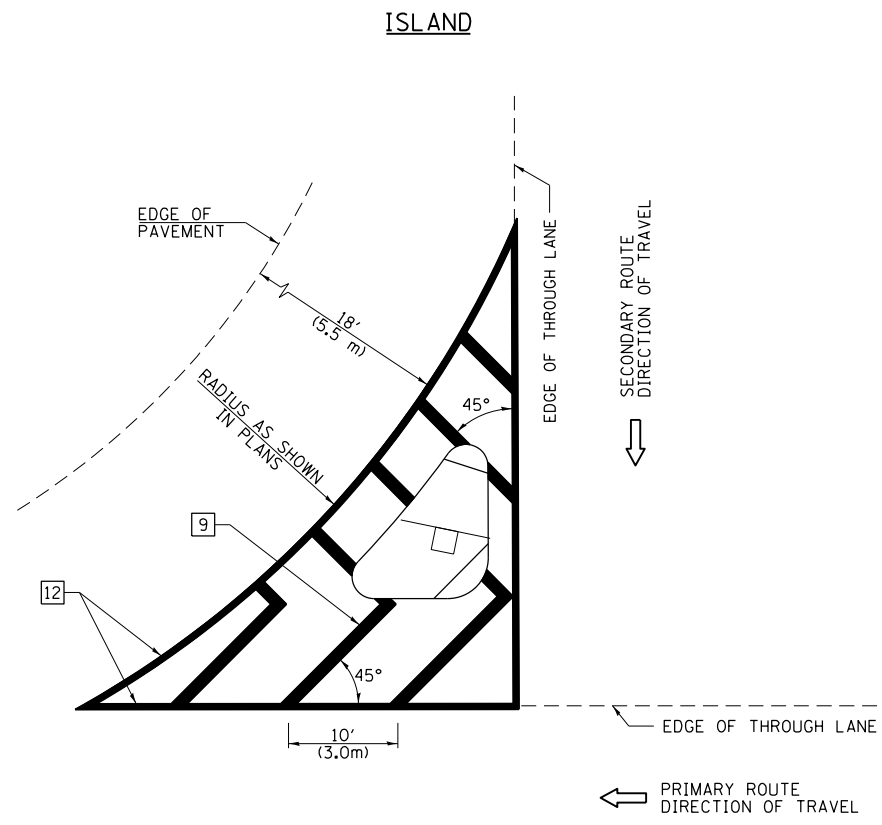

GENERAL NOTES

1. RAISED AND CORRUGATED MEDIANS SHALL BE OUTLINED WITH [2] IF PRESENT.
2. SOME OF THE INFORMATION INCLUDED WITH THIS DETAIL MAY NOT BE APPLICABLE TO THIS IMPROVEMENT.
3. PAVEMENT MARKINGS ARE TO BE EXTENDED THROUGH OMISSIONS WHEN APPLICABLE.
4. FINAL PAVEMENT MARKINGS SHALL BE IN PLACE PRIOR TO PLACING ANY RAISED REFLECTIVE PAVEMENT MARKERS.
5. THE FOLLOWING CRITERIA SHALL BE USED FOR SELECTING THE DIAGONAL PAVEMENT MARKING SPACING:

< 30 MPH (< 50 km/h)	15' (4.5 m)
30-45 MPH (50-75 km/h)	20' (6.0 m)
>45 MPH (>75 km/h)	30' (9.0 m)

PAVEMENT MARKING LEGEND

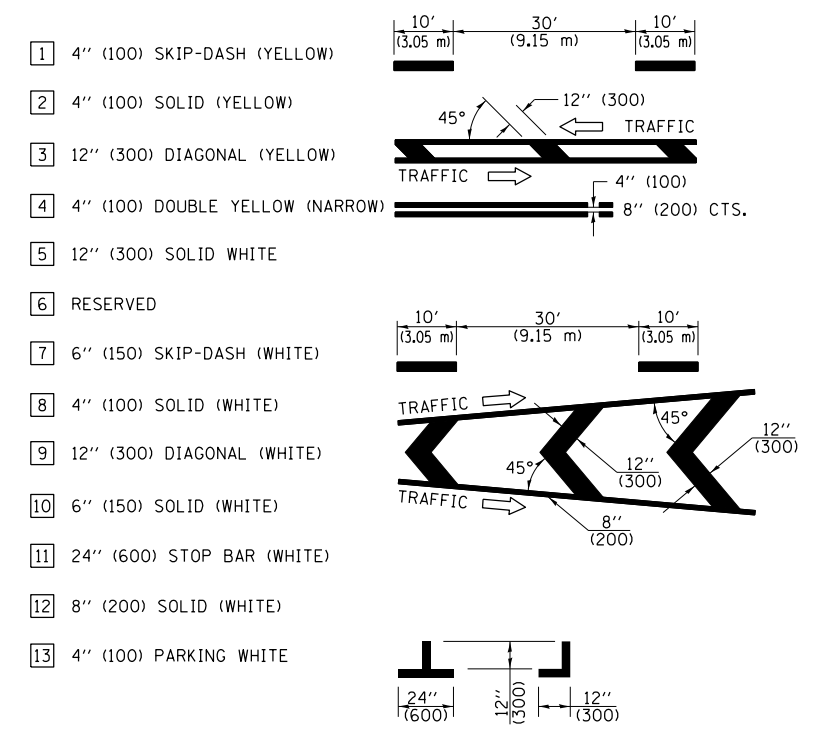

RURAL LEFT TURN STRIPING

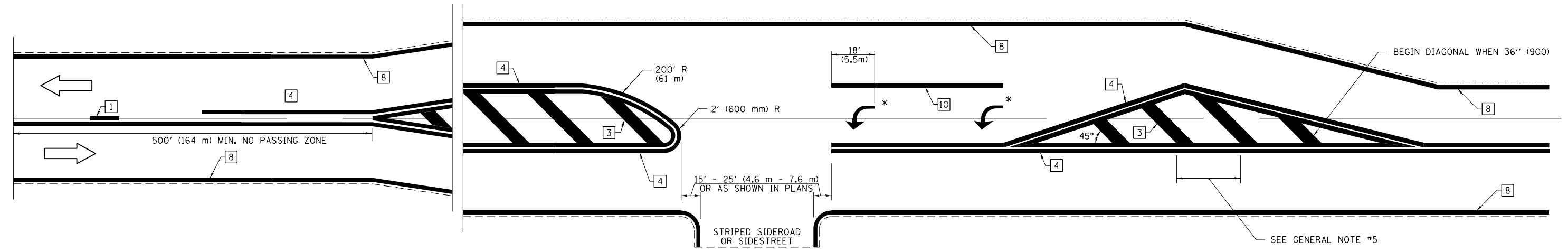

* PLACE AN ARROW 18' (5.5 m) BACK FROM STOP BAR. PLACE ANOTHER ARROW EVEN WITH THE BEGINNING OF THE SOLID WHITE LINE. SPACE ADDITIONAL ARROWS EVENLY UP TO 80' (24.4 m) MAXIMUM SPACING. USE MINIMUM OF 2 ARROWS.

NOT TO SCALE
 Note: All dimensions are in INCHES (millimeters) unless otherwise shown.

DISTRICT 7 DETAIL NO. 7800001

FILE NAME =	USER NAME = steffenmk	DESIGNED -	REVISED -
pw:\planroom.dot.illinois.gov\PIDOT\Documents\IDOT Offices\District 7\Projects\74710\DRAWING\CADsheets\0774710-sht-DETAILS.dwg		REVISION	REVISION
PLOT SCALE = 80.0000' / in.	CHECKED -	REVISION	REVISION
PLOT DATE = 2/20/2020	DATE -	REVISION	REVISION

**STATE OF ILLINOIS
 DEPARTMENT OF TRANSPORTATION**

**PAVEMENT MARKING AND RAISED REFLECTIVE PAVEMENT MARKERS
 (RURAL & URBAN APPLICATIONS)**
 SCALE: SHEET NO. 3 OF 4 SHEETS STA. TO STA.

F.A.P. RTE.	SECTION	COUNTY	TOTAL SHEETS	SHEET NO.
*	(137Z, 139-X-2)RS-2	MACON	262	253
*F.A.P. RTE. 320, 323, 323A			CONTRACT NO. 74710	
ILLINOIS FED. AID PROJECT				

PAVEMENT MARKINGS AT RAILROAD-HIGHWAY GRADE CROSSING

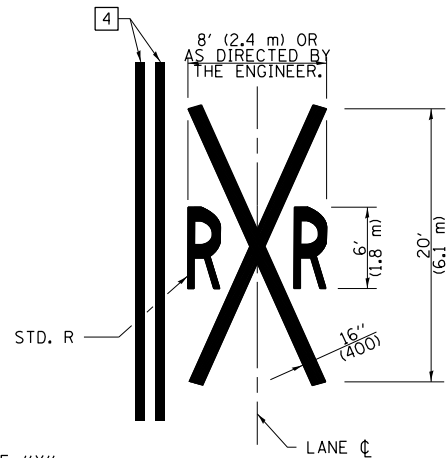
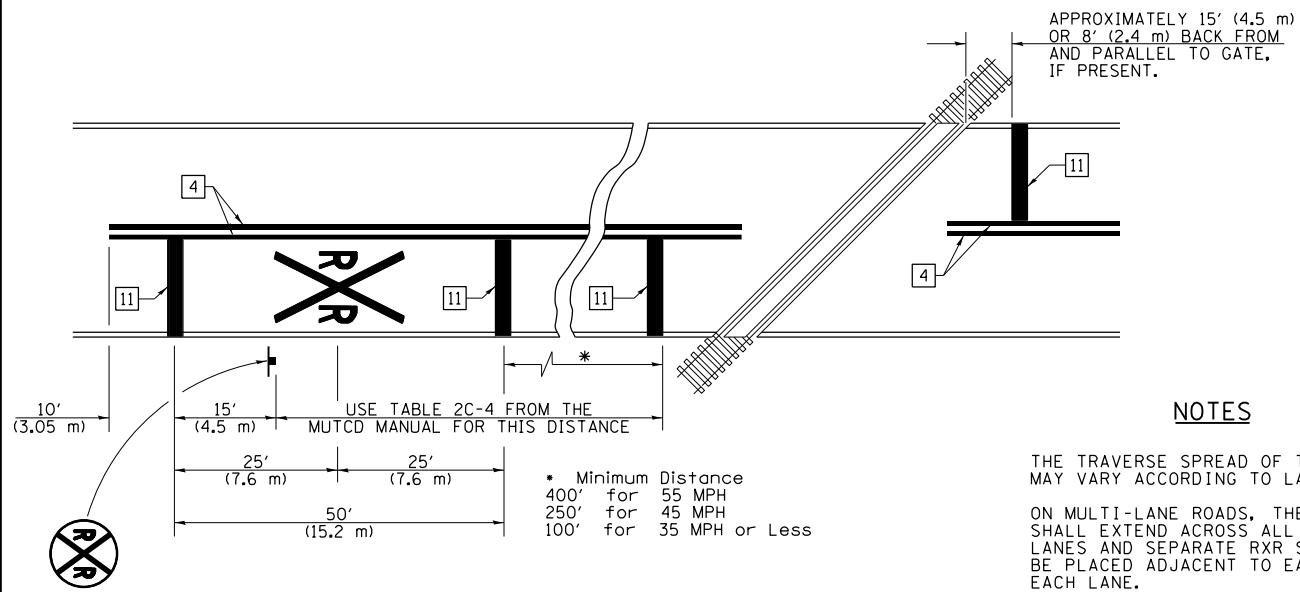

NOTES

THE TRAVERSE SPREAD OF THE "X" MAY VARY ACCORDING TO LANE WIDTH.

ON MULTI-LANE ROADS, THE STOP LINES SHALL EXTEND ACROSS ALL APPROACH LANES AND SEPARATE R X R SYMBOLS SHALL BE PLACED ADJACENT TO EACH OTHER IN EACH LANE.

WHEN THE PAVEMENT MARKING SYMBOL IS USED, A PORTION OF THE SYMBOL SHOULD BE LOCATED DIRECTLY ADJACENT TO THE ADVANCE WARNING SIGN (W10-1) AS PLACED BY TABLE II-1, CONDITION B OF THE MUTCD.

PAVEMENT MARKING LEGEND

- 1 4" (100) SKIP-DASH (YELLOW)
- 2 4" (100) SOLID (YELLOW)
- 3 12" (300) DIAGONAL (YELLOW)
- 4 4" (100) DOUBLE YELLOW (NARROW)
- 5 12" (300) SOLID WHITE
- 6 RESERVED
- 7 6" (150) SKIP-DASH (WHITE)
- 8 4" (100) SOLID (WHITE)
- 9 12" (300) DIAGONAL (WHITE)
- 10 6" (150) SOLID (WHITE)
- 11 24" (600) STOP BAR (WHITE)
- 12 8" (200) SOLID (WHITE)
- 13 4" (100) PARKING WHITE

RAILROAD CROSSING WITH INTERCONNECT ONLY

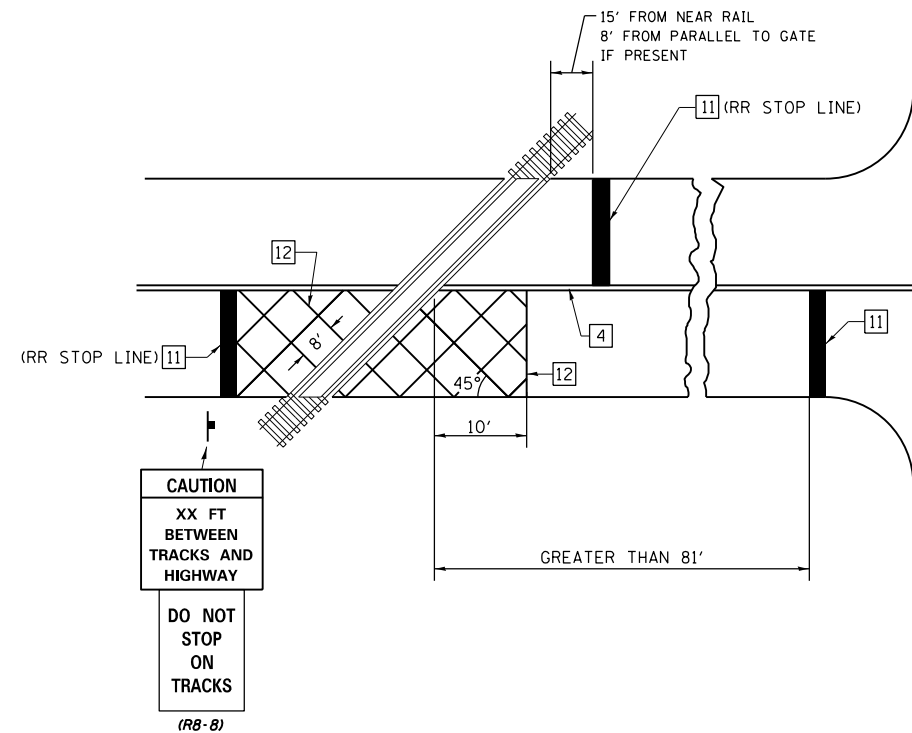

RAILROAD CROSSING WITH INTERCONNECT AND PRE-SIGNALS

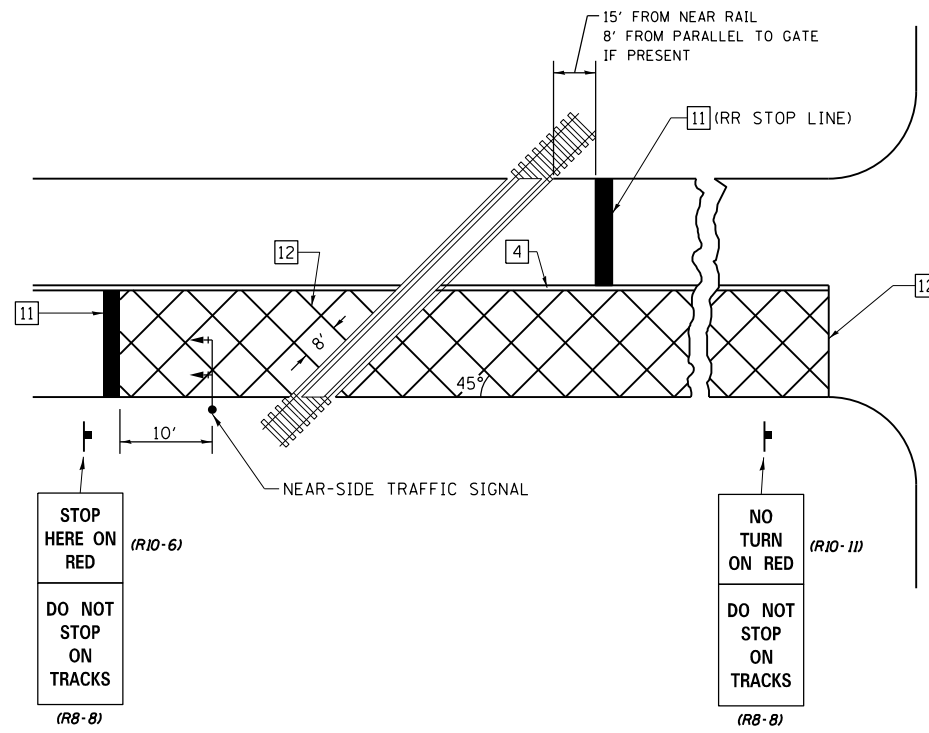

GENERAL NOTES

- SUPPLEMENTAL PAVEMENT MARKINGS TO BE INSTALLED ONLY ON APPROACHES TO INTERSECTIONS CONTROLLED BY TRAFFIC SIGNALS WHICH ARE INTERCONNECTED WITH THE RAILROAD WARNING SIGNALS.
- EXTEND PAVEMENT MARKINGS TO THE INTERSECTION ONLY WHERE NEAR-SIDE TRAFFIC SIGNALS ARE USED.

SUPPLEMENTAL PAVEMENT MARKING TREATMENT FOR RAILROAD-HIGHWAY GRADE CROSSING

NOT TO SCALE

Note: All dimensions are in INCHES (millimeters) unless otherwise shown.

DISTRICT 7 DETAIL NO. 7800001

FILE NAME =	USER NAME = steffenmk	DESIGNED -	REVISED -	STATE OF ILLINOIS DEPARTMENT OF TRANSPORTATION	PAVEMENT MARKING AND RAISED REFLECTIVE PAVEMENT MARKERS (RURAL & URBAN APPLICATIONS)	F.A.P. RTE.	SECTION	COUNTY	TOTAL SHEETS	SHEET NO.
pw:\planroom.dot.illinois.gov\PIWIDOT\Documents\IDOT Offices\District 7\Projects\74710\CDRAW\CADsheets\0774710-sht-DETAILS.dgn	PLLOT SCALE = 80.0000' / in.	CHECKED -	REVISED -			* (137Z, 139-X-2)RS-2	MACON	262	254	
	PLLOT DATE = 2/20/2020	DATE -	REVISED -			*F.A.P. RTE. 320, 323, 323A	CONTRACT NO. 74710			
						ILLINOIS FED. AID PROJECT				

SCALE: SHEET NO. 4 OF 4 SHEETS STA. TO STA.

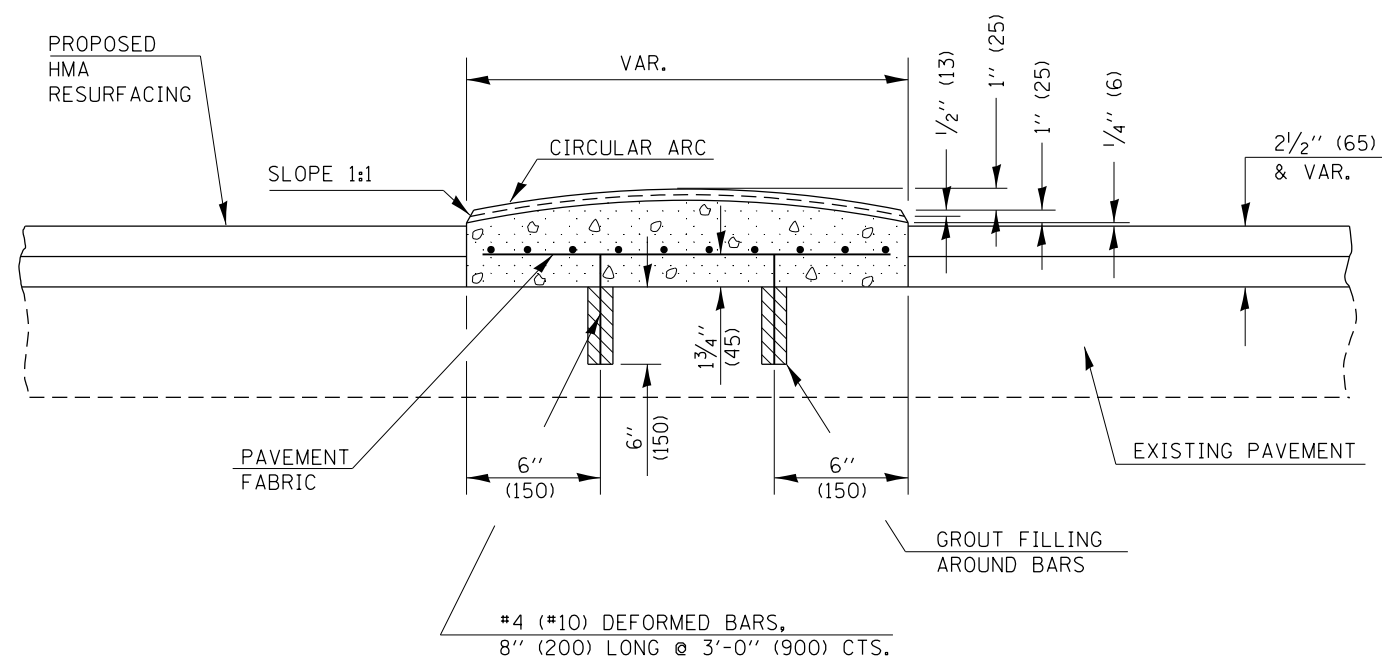

TRANSVERSE SECTION

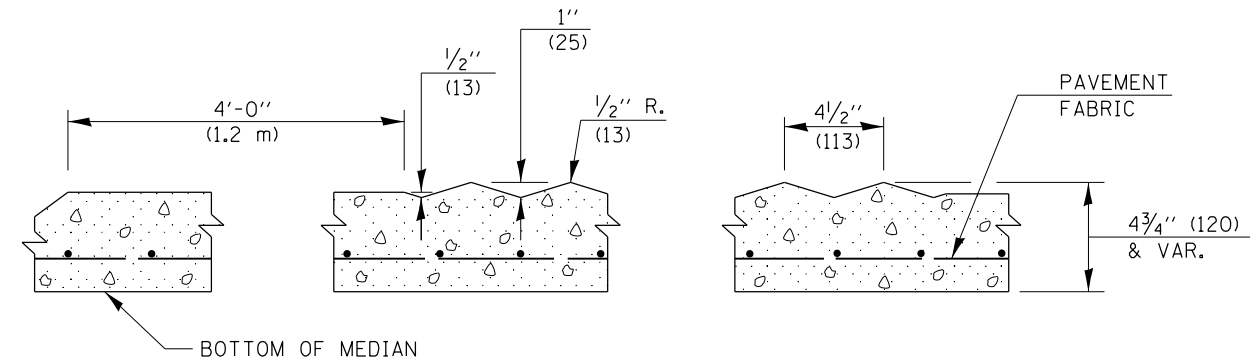

SECTION A-A

GENERAL NOTES

1. DOWELS AT 3'-0" (900) INTERVALS OR AS DIRECTED BY THE ENGINEER.
2. SEE STANDARD 420701 FOR PAVEMENT FABRIC DETAILS.

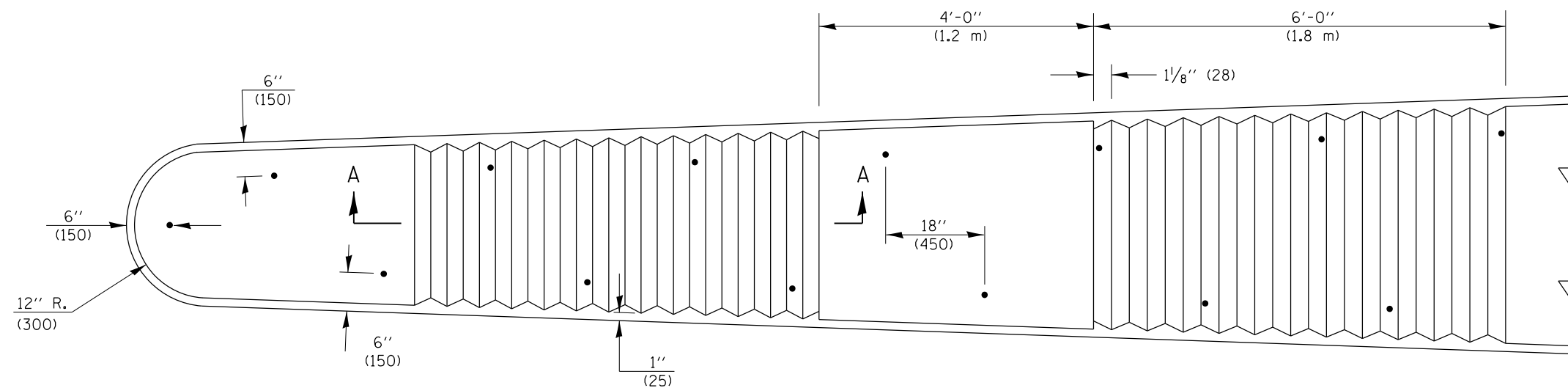

PLAN

Note: All dimensions are in INCHES (millimeters) unless otherwise shown.

DISTRICT 7 DETAIL NO. 60624610

FILE NAME =	USER NAME = steffenmk	DESIGNED -	REVISED - DRM 1/09
pw:\planroom.dot.illinois.gov\PIDOT\Documents\IDOT Offices\District 7\Projects\74710\CAD\CAD sheets\0774710-sht-DETAILS.dgn		CHECKED -	REVISED -
		DATE -	REVISED -

**STATE OF ILLINOIS
DEPARTMENT OF TRANSPORTATION**

CORRUGATED MEDIAN (DOWELLED)

SCALE: SHEET NO. OF SHEETS STA. TO STA.

F.A.P. RTE.	SECTION	COUNTY	TOTAL SHEETS	SHEET NO.
*	(137Z, 139-X-2) R5-2	MACON	262	255
* F.A.P. RTE 320, 323, 323A			CONTRACT NO. 74710	
FED. ROAD DIST. NO.	ILLINOIS FED. AID PROJECT			

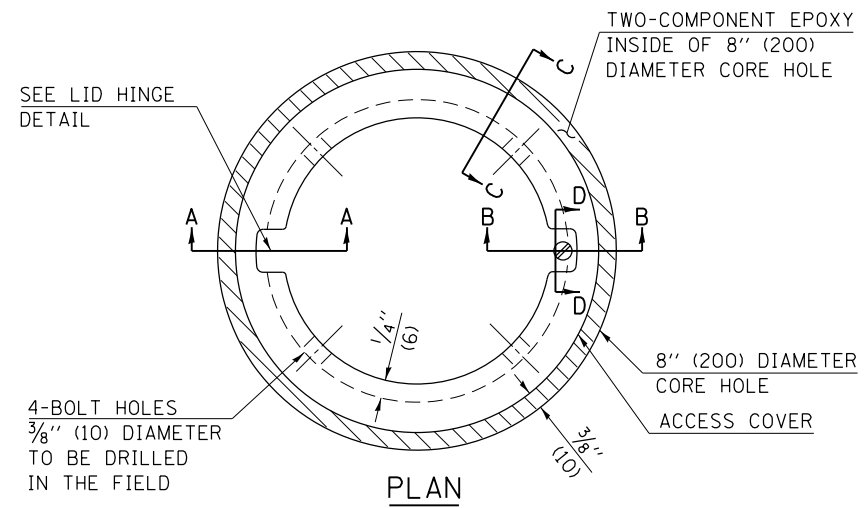

LEGEND

- ALUMINUM CASTING
- 5" (125) OR 6" (150) P.V.C. PIPE
- TWO-COMPONENT EPOXY

T = THICKNESS OF PAVEMENT STRUCTURE
 H = THE THICKNESS OF THE SUB-BASE GRANULAR + 1" (25)

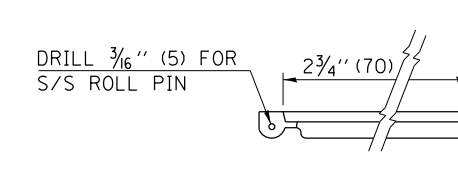
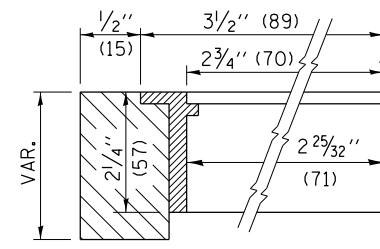

BILL OF MATERIAL	
ALUMINUM CASTING OF THE DIMENSIONS AND SPECIFICATIONS SHOWN OR OTHER SUBJECT TO ENGINEER'S APPROVAL OF SHOP DRAWINGS,	
4 EACH - 5/16" X 2" (M8 X 50) BOLTS WITH NUTS, EPOXY,	
5" OR 6" (125 mm OR 150 mm) DIAMETER P.V.C. PIPE, SCHEDULE 40 (WHEN REQUIRED).	

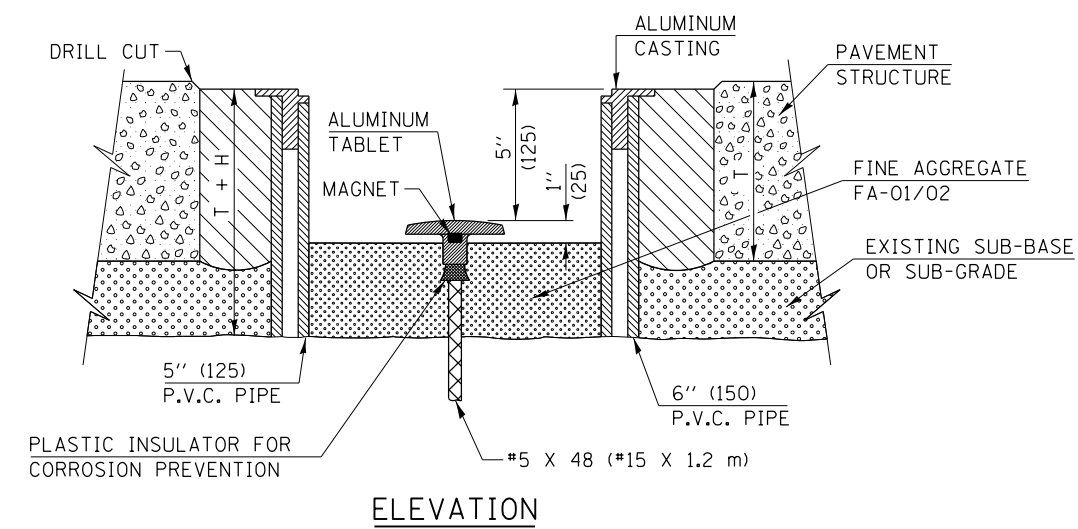
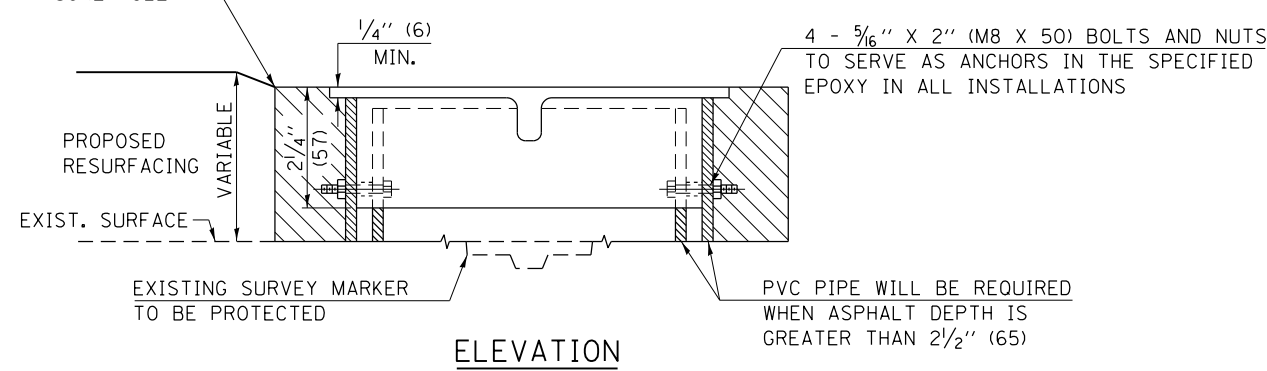
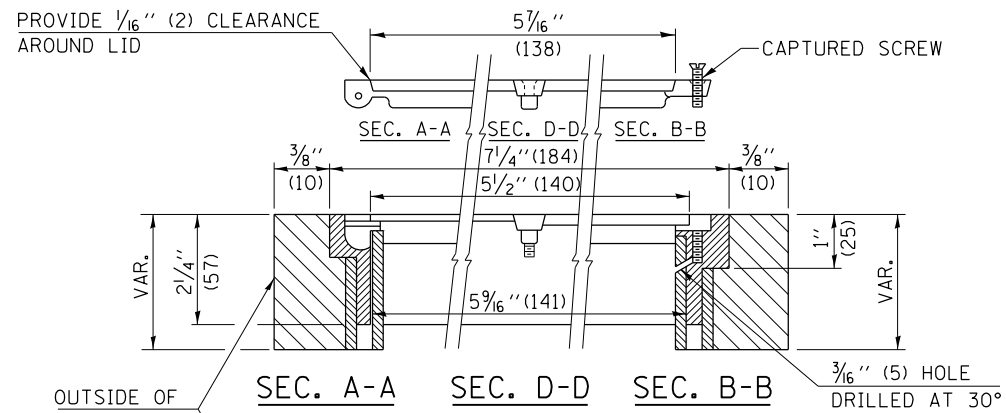

NOT TO SCALE

FILE NAME =	USER NAME = steffennk	DESIGNED -	REVISED - MAD 6-11
pw:\planroom.dot.illinois.gov\PIDOT\Documents\IDOT Offices\District 7\Projects\74710\CAD\CADsheets\0774710-sht-DETAILS.dgn		REVISION	REVISED -
	PLOT SCALE = 99.7920' / in.	CHECKED -	REVISED -
	PLOT DATE = 2/20/2020	DATE -	REVISED -

STATE OF ILLINOIS
 DEPARTMENT OF TRANSPORTATION

SURVEY MARKER VAULT

SCALE:	SHEET NO.	OF SHEETS	STA.	TO STA.
--------	-----------	-----------	------	---------

DISTRICT 7 DETAIL NO. 20070202				
F.A.P. RTE.	SECTION	COUNTY	TOTAL SHEETS	SHEET NO.
*	(137Z, 139-X-2) R5-2	MACON	262	256
* F.A.P. RTE 320, 323, 323A			CONTRACT NO. 74710	
FED. ROAD DIST. NO. ILLINOIS FED. AID PROJECT				

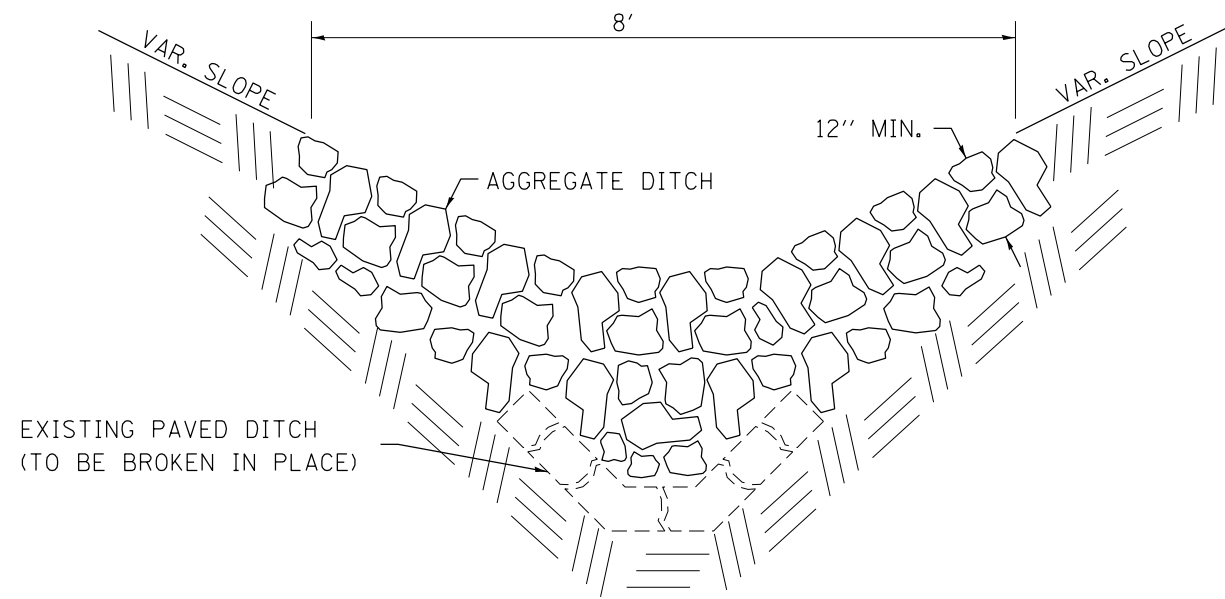

DETAIL OF AGGREGATE DITCH

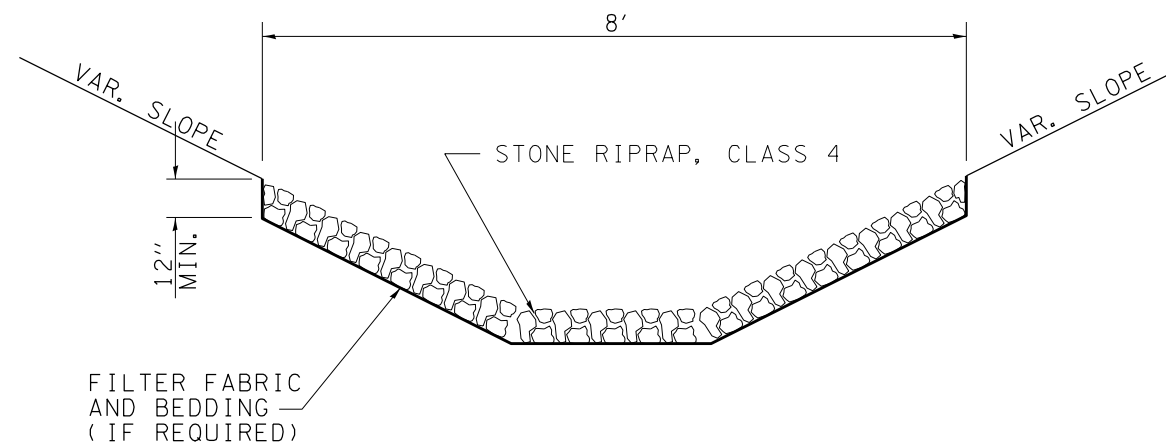

DETAIL OF RIPRAP, CLASS 4

MODEL: Default
 FILE: h:\a\c\p\sup\h\room\dat\illinois\gov\p\w\dot\Documents\DOT_Offices\Detail\7\Projects\71710\CADD\ata\CAD\sheet\071710-shc-DETAILS.dgn

USER NAME = steffenmk	DESIGNED -	REVISED -
	DRAWN -	REVISED -
PLOT SCALE = 100.0000 ' / in.	CHECKED -	REVISED -
PLOT DATE = 2/20/2020	DATE -	REVISED -

**STATE OF ILLINOIS
DEPARTMENT OF TRANSPORTATION**

AGGREGATE DITCH (SPECIAL)/RIP RAP DETAILS			
SCALE:	SHEET 1	OF 1 SHEETS	STA. TO STA.

F.A.P. RTE.	SECTION	COUNTY	TOTAL SHEETS	SHEET NO.
*	(137Z, 139-X-2)RS-2	MACON	262	257
*F.A.P. RTE. 320, 323, 323A			CONTRACT NO. 74710	
ILLINOIS FED. AID PROJECT				

FINAL SURVEY NO.	SURVEYED	BY	DATE
NOTE BOOK	PLOTTED		
AREAS CHECKED	TEMPLATE		
	AREAS CHECKED		

ORIGINAL SURVEY NO.	SURVEYED	BY	DATE
NOTE BOOK	PLOTTED		
AREAS CHECKED	TEMPLATE		
	AREAS CHECKED		

MODEL: Default
FILE NAME: D:\a\l\m\com\ad\illinois\gov\p\w\DOT\Documents\DOT - Offices\District 7\Projects\71710\CAD\Drawings\DOT - Cross Sections.dwg

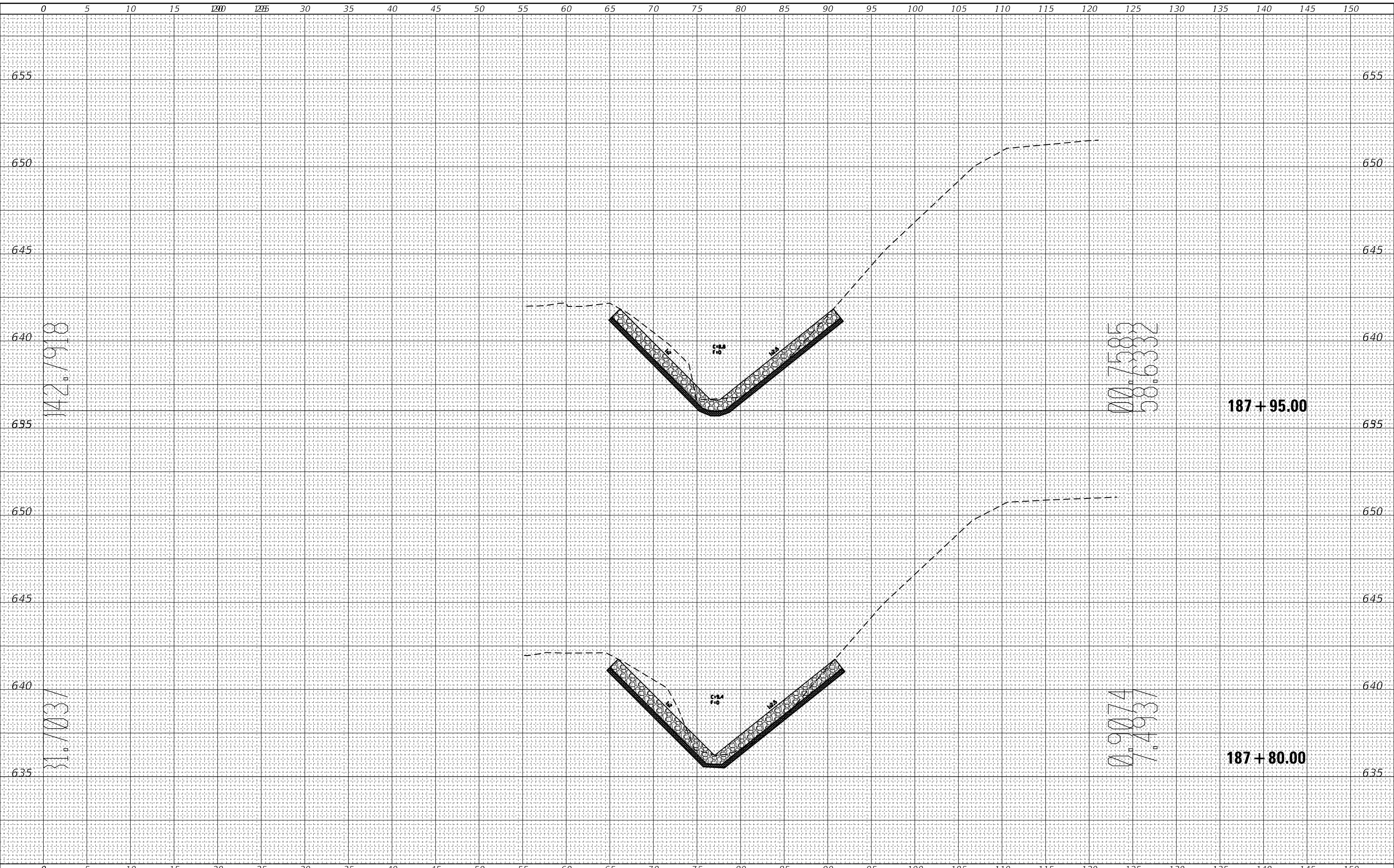

USER NAME = stefenmk	DESIGNED -	REVISED -
	DRAWN -	REVISED -
PLOT SCALE = 10.0000 "/td> <td>CHECKED -</td> <td>REVISED -</td>	CHECKED -	REVISED -
PLOT DATE = 2/20/2020	DATE -	REVISED -

**STATE OF ILLINOIS
DEPARTMENT OF TRANSPORTATION**

**AGGREGATE DITCH
CROSS SECTIONS**

SCALE: SHEET 1 OF 5 SHEETS STA. 187+80.00 TO STA. 187+95.00

F.A.P. RTE.	SECTION	COUNTY	TOTAL SHEETS	SHEET NO.
*	(137Z, 139-X-2)RS-2	MACON	262	258
*F.A.P. RTE 320, 323, 323A			CONTRACT NO. 74710	
ILLINOIS		FED. AID PROJECT		

FINAL SURVEY NO.	SURVEYED	BY	DATE
NOTE BOOK	PLOTTED		
AREAS CHECKED	TEMPLATE		
	AREAS CHECKED		

ORIGINAL SURVEY NO.	SURVEYED	BY	DATE
NOTE BOOK	PLOTTED		
AREAS CHECKED	TEMPLATE		
	AREAS CHECKED		

MODEL: Default
FILE NAME: D:\a\blm\com\ad\illinois\gov\p\w\DOT\Documents\DOT_Offices\District_7\Projects\717\DCAD\Batt\CAD\Batt\CAD\Sheets\171710-SHT - Cross Sections.dwg

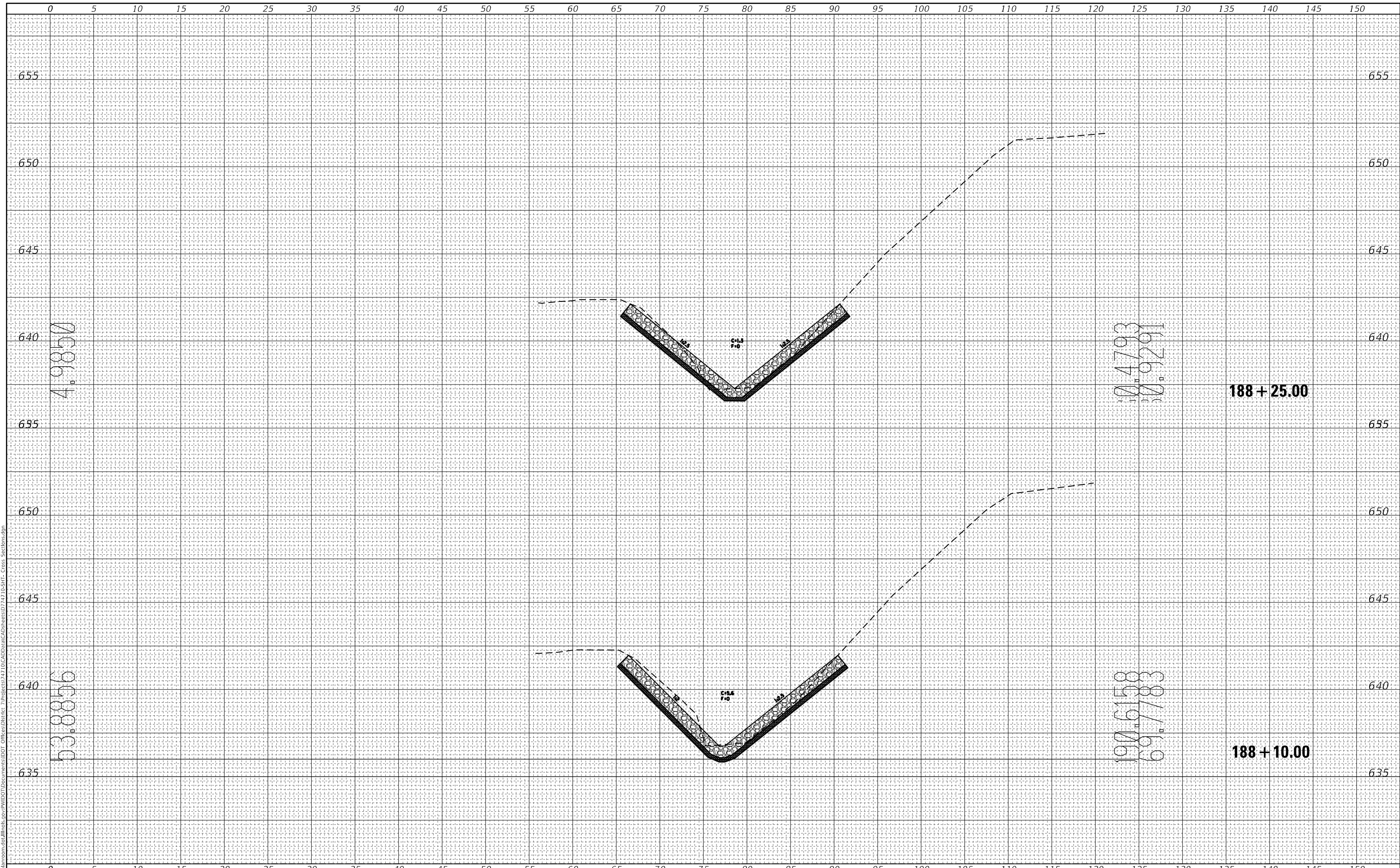

4.9850

10.4793
10.9291

188 + 25.00

63.8856

190.6158
69.7783

188 + 10.00

USER NAME = stefenmk	DESIGNED -	REVISED -
	DRAWN -	REVISED -
PLOT SCALE = 10.0000 ' / in.	CHECKED -	REVISED -
PLOT DATE = 2/20/2020	DATE -	REVISED -

**STATE OF ILLINOIS
DEPARTMENT OF TRANSPORTATION**

**AGGREGATE DITCH
CROSS SECTIONS**

SCALE: SHEET 2 OF 5 SHEETS STA. 188+10.00 TO STA. 188+25.00

F.A.P. RTE.	SECTION	COUNTY	TOTAL SHEETS	SHEET NO.
*	(137Z, 139-X-2)RS-2	MACON	262	259
*F.A.P. RTE 320, 323, 323A			CONTRACT NO. 74710	
ILLINOIS		FED. AID PROJECT		

FINAL SURVEY NO.	SURVEYED	BY	DATE
NOTE BOOK	PLOTTED		
AREAS CHECKED	TEMPLATE		
	AREAS CHECKED		

ORIGINAL SURVEY NO.	SURVEYED	BY	DATE
NOTE BOOK	PLOTTED		
AREAS CHECKED	TEMPLATE		
	AREAS CHECKED		

MODEL: Default
 FILE NAME: D:\a\blm\com\ad\illinois\gov\p\w\dot\Documents\DOT - Offices\District 7\Projects\717\DCAD\BataCAD\Sheet\171710-SHT - Cross Sections.dgn

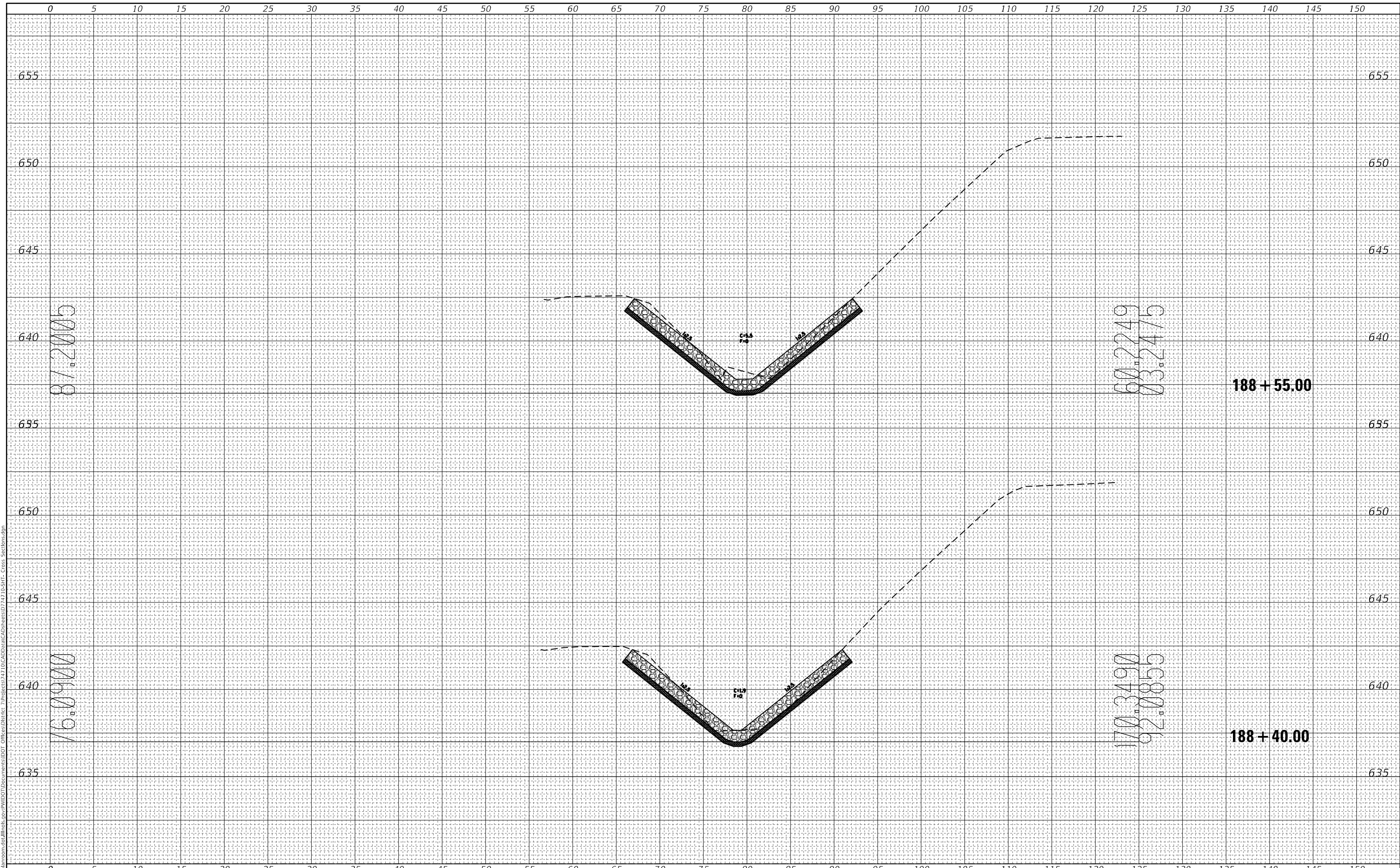

USER NAME = stefenmk	DESIGNED -	REVISED -
	DRAWN -	REVISED -
PLOT SCALE = 10.0000 ' / in.	CHECKED -	REVISED -
PLOT DATE = 2/20/2020	DATE -	REVISED -

**STATE OF ILLINOIS
 DEPARTMENT OF TRANSPORTATION**

**AGGREGATE DITCH
 CROSS SECTIONS**

SCALE: SHEET 3 OF 5 SHEETS STA. 188+40.00 TO STA. 188+55.00

F.A.P. RTE.	SECTION	COUNTY	TOTAL SHEETS	SHEET NO.
*	(137Z, 139-X-2)RS-2	MACON	262	260
*F.A.P. RTE 320, 323, 323A		CONTRACT NO. 74710		
ILLINOIS		FED. AID PROJECT		

FINAL SURVEY NO.	SURVEYED	BY	DATE
NOTE BOOK	PLOTTED		
AREAS CHECKED	TEMPLATE		
	AREAS CHECKED		

ORIGINAL SURVEY NO.	SURVEYED	BY	DATE
NOTE BOOK	PLOTTED		
AREAS CHECKED	TEMPLATE		
	AREAS CHECKED		

MODEL: Default
FILE NAME: D:\a\blm\com\ad\illinois\gov\p\w\DOT\Documents\DOT - Office\District 7\Projects\71710\CAD\Drawings\DOT - Cross Sections.dwg

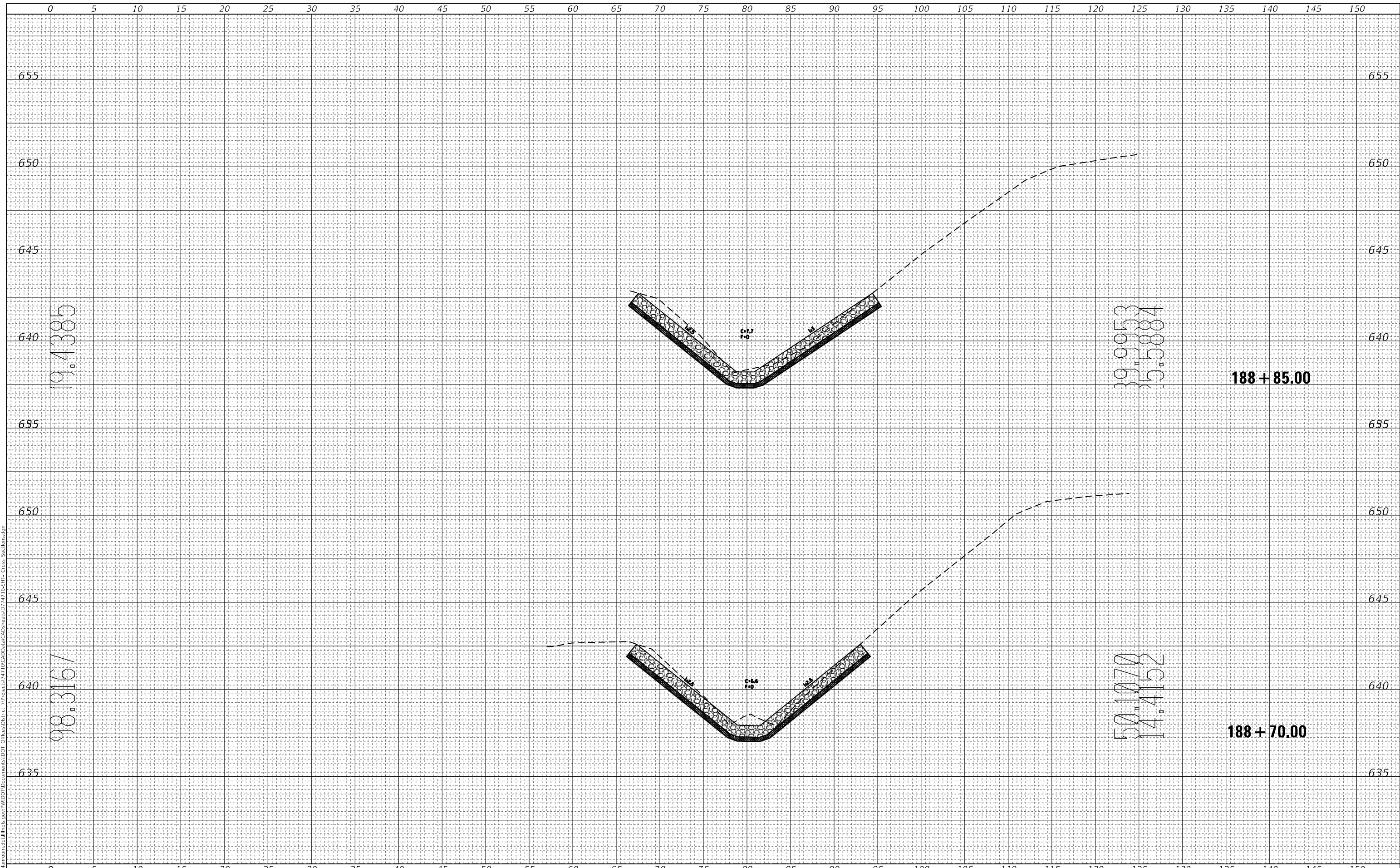

USER NAME = stefenmk	DESIGNED -	REVISED -
	DRAWN -	REVISED -
PLOT SCALE = 10.0000 ' / in.	CHECKED -	REVISED -
PLOT DATE = 2/20/2020	DATE -	REVISED -

**STATE OF ILLINOIS
DEPARTMENT OF TRANSPORTATION**

**AGGREGATE DITCH
CROSS SECTIONS**

SCALE: SHEET 4 OF 5 SHEETS STA. 188+70.00 TO STA. 188+85.00

F.A.P. RTE.	SECTION	COUNTY	TOTAL SHEETS	SHEET NO.
*	(137Z, 139-X-2)RS-2	MACON	262	261
*F.A.P. RTE 320, 323, 323A			CONTRACT NO. 74710	
ILLINOIS		FED. AID PROJECT		

FINAL SURVEY NO.	SURVEYED	BY	DATE
NOTE BOOK	PLOTTED		
TEMPLATE	AREAS CHECKED		
AREAS CHECKED			

ORIGINAL SURVEY NO.	SURVEYED	BY	DATE
NOTE BOOK	PLOTTED		
TEMPLATE	AREAS CHECKED		
AREAS CHECKED			

MODEL: Default
FILE NAME: D:\a\blm\com\ad\illinois\gov\p\w\DOT\Documents\DOT - Offices\District 7\Projects\71710\CAD\Drawings\71710-SHT - Cross Sections.dwg

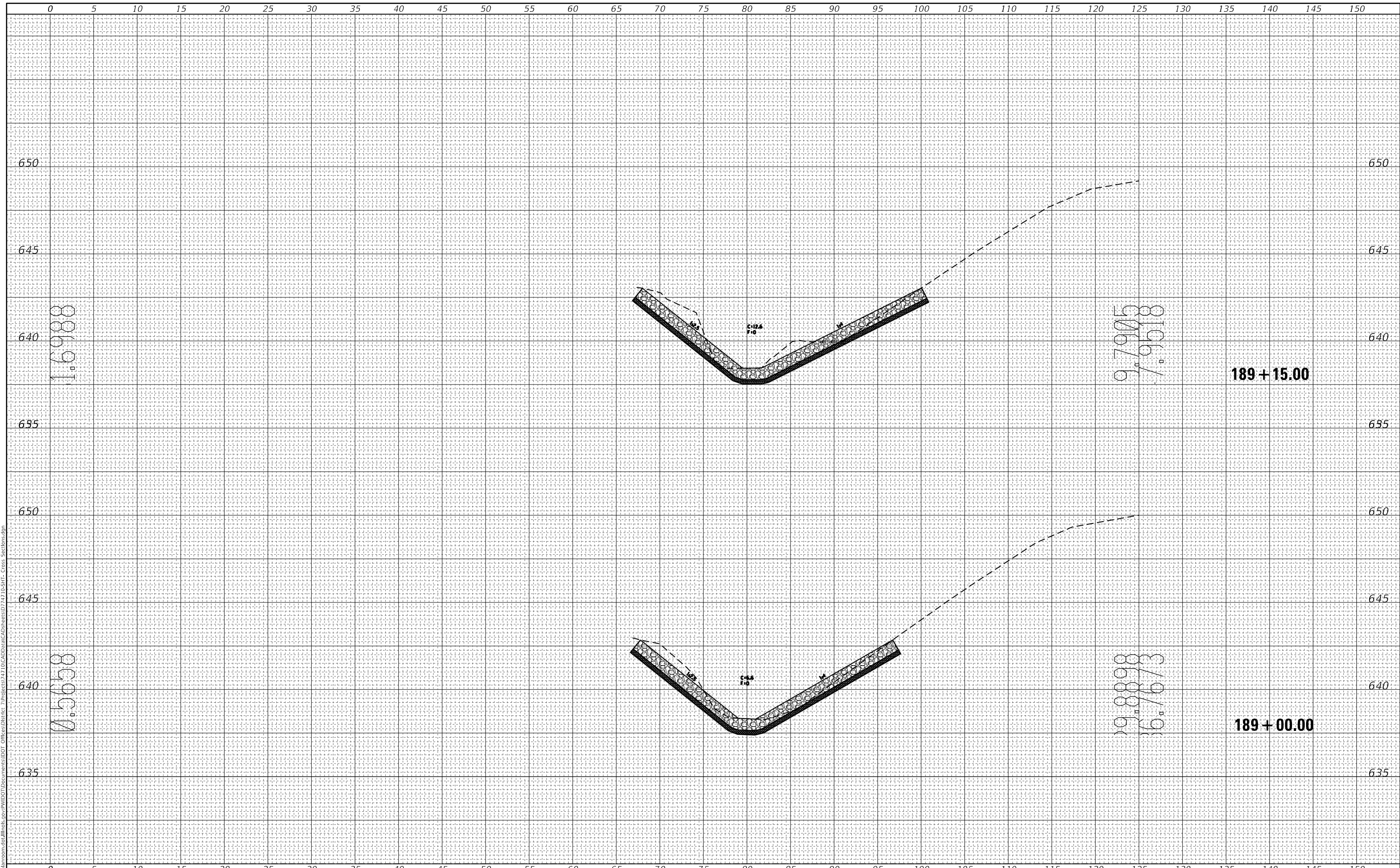

USER NAME = stefenmk	DESIGNED -	REVISED -
	DRAWN -	REVISED -
PLOT SCALE = 10.0000 ' / in.	CHECKED -	REVISED -
PLOT DATE = 2/20/2020	DATE -	REVISED -

**STATE OF ILLINOIS
DEPARTMENT OF TRANSPORTATION**

**AGGREGATE DITCH
CROSS SECTIONS**

SCALE: SHEET 5 OF 5 SHEETS STA. 189+00.00 TO STA. 189+15.00

F.A.P. RTE.	SECTION	COUNTY	TOTAL SHEETS	SHEET NO.
*	(137Z, 139-X-2)RS-2	MACON	262	262
*F.A.P. RTE 320, 323, 323A			CONTRACT NO. 74710	
ILLINOIS		FED. AID PROJECT		