

INSTRUCTIONS

ABOUT IDOT PROPOSALS: All proposals are potential bidding proposals. Each proposal contains all certifications and affidavits, a proposal signature sheet and a proposal bid bond.

PREQUALIFICATION

Any contractor who desires to become pre-qualified to bid on work advertised by IDOT must submit the properly completed pre-qualification forms to the Bureau of Construction no later than 4:30 p.m. prevailing time twenty-one days prior to the letting of interest. This pre-qualification requirement applies to first time contractors, contractors renewing expired ratings, contractors maintaining continuous pre-qualification or contractors requesting revised ratings. To be eligible to bid, existing pre-qualification ratings must be effective through the date of the letting.

WHO CAN BID?

Bids will be accepted from only those companies that request and receive written Authorization to Bid from IDOT's Central Bureau of Construction.

REQUESTS FOR AUTHORIZATION TO BID

Contractors wanting to bid on items included in a particular letting must submit the properly completed "Request for Authorization to Bid/or Not For Bid Status" (BDE 124) and the ORIGINAL "Affidavit of Availability: (BC 57) to the proper office no later than 4:30 p.m. prevailing time, three (3) days prior to the letting date.

WHAT CONSTITUTES WRITTEN AUTHORIZATION TO BID?: When a prospective prime bidder submits a "Request for Authorization to Bid or Not for Bid Status" (BDE 124) he/she must indicate at that time which items are being requested For Bidding purposes. Only those items requested For Bidding will be analyzed. After the request has been analyzed, the bidder will be issued an **Authorization to Bid or Not for Bid Report**, approved by the Central Bureau of Construction and the Chief Procurement Officer that indicates which items have been approved For Bidding. If **Authorization to Bid** cannot be approved, the **Authorization to Bid or Not for Bid Report** will indicate the reason for denial.

ABOUT AUTHORIZATION TO BID: Firms that have not received an Authorization to Bid or Not For Bid Report within a reasonable time of complete and correct original document submittal should contact the department as to the status. Firms unsure as to authorization status should call the Prequalification Section of the Bureau of Construction at the number listed at the end of these instructions. These documents must be received three days before the letting date.

ADDENDA AND REVISIONS: It is the bidder's responsibility to determine which, if any, addenda or revisions pertain to any project they may be bidding. Failure to incorporate all relevant addenda or revisions may cause the bid to be declared unacceptable.

Each addendum or revision will be included with the Electronic Plans and Proposals. Addenda and revisions will also be placed on the Addendum/Revision Checklist and each subscription service subscriber will be notified by e-mail of each addendum and revision issued.

The Internet is the Department's primary way of doing business. The subscription server e-mails are an added courtesy the Department provides. It is suggested that bidders check IDOT's website at <http://www.idot.illinois.gov/doing-business/procurements/construction-services/construction-bulletins/transportation-bulletin/index> before submitting final bid information.

IDOT IS NOT RESPONSIBLE FOR ANY E-MAIL FAILURES.

Addenda questions may be directed to the Contracts Office at (217)782-7806 or DOT.D&Econtracts@illinois.gov.

Technical questions about downloading these files may be directed to Tim Garman at (217)524-1624 or Timothy.Garman@illinois.gov.

BID SUBMITTAL GUIDELINES AND CHECKLIST

- All pages should be single sided.
- Use the Cover Page that is provided in the Bid Proposal (posted on the IDOT Web Site) as the first page of your submitted bid. It has the Item number in large bold type in the upper left-hand corner of the page.
- Do not use report covers, presentation folders or special bindings and do not staple multiple times on left side like a book. Use only 1 staple in the upper left hand corner.
- Do not include any certificates of eligibility, your authorization to bid, Addendum Letters or affidavit of availability.
- Do not include the Subcontractor Documentation with your bid (pages 30-38).
- Use the envelope cover sheet (provided with the proposal) as the cover for the proposal envelope.
- Do not rely on overnight services to deliver your proposal prior to 10 AM on letting day. It will not be read if it is delivered after 10 AM.
- Do not submit your Substance Abuse Prevention Program (SAPP) with your bid. If you are awarded the contract this form is to be submitted to the Division Construction Engineer at the pre-construction conference.

BID SUBMITTAL CHECKLIST

Cover page (the sheet that has the item number on it) – This should be the first page of your proposal, **followed by your bid (the Pay Items)**. If you are using special software or CBID to generate your schedule of prices, do not include the blank schedule of prices that came with the proposal package.

Page 4 (Item 9) - Check “YES” if you will use a subcontractor(s) with an annual value over \$50,000. Include the subcontractor(s) name, address, general type of work to be performed and the dollar amount. If you will use subcontractor(s) but are uncertain who or the dollar amount; check “YES” but leave the lines blank.

After Page 4 – Insert the following documents: Cost Adjustments for Steel, Bituminous, and Fuel (if applicable) and the Contractor Letter of Assent (if applicable). The general rule should be, if you don’t know where it goes, put it after page 4.

Page 10 (Paragraph J) - Check “YES” or “NO” whether your company has any business in Iran.

Page 10 (Paragraph K) – (Not applicable to federally funded projects) List the name of the apprenticeship and training program sponsor holding the certificate of registration from the US Department of Labor. If no applicable program exists, please indicate the work/job category. **Your bid will not be read if this is not completed.** Do not include certificates with your bid. Keep the certificates in your office in case they are requested by IDOT.

Page 11 (Paragraph L) – A copy of your State Board of Elections certificate of registration is no longer required with your bid.

Page 11 (Paragraph M) – Indicate if your company has hired a lobbyist in connection with the job for which you are submitting the bid proposal.

Page 12 (Paragraph C) - This is a work sheet to determine if a completed Form A is required. It is not part of the form and you do not need to make copies for each completed Form A.

Pages 14-17 (Form A) - One Form A (4 pages) is required for each applicable person in your company. Copies of the Forms can be used and only need to be changed when the financial information changes. The certification signature and date must be original for each letting. **Do not staple the forms together.** If you answered “NO” to all of the questions in Paragraph C (page 12), complete the first section (page 14) with your company information and then sign and date the Not Applicable statement on page 17.

Page 18 (Form B) - If you check “YES” to having other current or pending contracts it is acceptable to use the phrase, “See Affidavit of Availability on file”. **Ownership Certification** (at the bottom of the page) – Check N/A if the Form A you submitted accounts for 100 percent of the company ownership. Check YES if any percentage of ownership falls outside of the parameters that require reporting on the Form A. Checking NO indicates that the Form A you submitted is not correct and you will be required to submit a revised Form A.

Pages 20-21 (Workforce Projection) - Be sure to include the Duration of the Project. It is acceptable to use the phrase “Per Contract Specifications”.

Proposal Bid Bond – (After the Proposal Signature Page) Submit your proposal bid bond (if applicable) using the current Bid Bond Form provided in the proposal package. The Power of Attorney page should be stapled to the Bid Bond. If you are using an electronic bond, include your bid bond number on the form and attach the Proof of Insurance printed from the Surety 2000 Web Site.

Disadvantaged Business Utilization Plan and/or Good Faith Effort - The last item in your bid should be the DBE Utilization Plan (SBE 2026), followed by the DBE Participation Statement (SBE 2025) and supporting paperwork. If you have documentation for a Good Faith Effort, it should follow the SBE Forms.

7A

RETURN WITH BID

Proposal Submitted By	
Name	
Address	
City/State	9 Digit Zip Code
Telephone No.	Fax No.
Federal Employer Identification No. (FEIN)	
Email Address	

Letting July 29, 2016

NOTICE TO PROSPECTIVE BIDDERS

This proposal can be used for bidding purposes by only those companies that request and receive written **AUTHORIZATION TO BID** from IDOT's Central Bureau of Construction.
BIDDERS NEED NOT RETURN THE ENTIRE PROPOSAL

Notice to Bidders, Specifications, Proposal, Contract and Contract Bond



Illinois Department of Transportation
DIVISION OF AERONAUTICS

Contract No. QU022
Quad City International Airport
Moline, Illinois
Rock Island County
Illinois Project No. MLI-4531
AIP Project No. 3-17-0068-XX

For engineering information, contact Travis Strait, P.E. of Crawford, Murphy & Tilly, Inc. at (309) 278-6214.

FAA rules prohibit the use of escalation clauses for materials. Therefore, the Division of Aeronautics cannot offer any material cost adjustment provisions for projects that utilize Federal funds.

PLEASE MARK THE APPROPRIATE BOX BELOW:

- A Bid Bond is included.
- A Cashier's Check or a Certified Check is included.
- An Annual Bid Bond is included or is on file with IDOT



PROPOSAL

TO THE DEPARTMENT OF TRANSPORTATION

1. Proposal of _____

Taxpayer Identification Number (Mandatory) _____

For the improvement identified and advertised for bids in the Invitation for Bids as:

**Contract No. QU022
Quad City International Airport
Moline, Illinois
Rock Island County
Illinois Project No. MLI-4531
AIP Project No. 3-17-0068-XX**

Construct Northwest Service Road – Phase 1

2. The undersigned bidder will furnish all labor, material and equipment to complete the above described project in a good workmanlike manner as provided in the contract documents provided by the Department of Transportation. This proposal will become part of the contract and the terms and conditions contained in the contract documents shall govern performance and payments.

3. **ASSURANCE OF EXAMINATION AND INSPECTION/WAIVER.** The undersigned bidder further declares that he/she has carefully examined the proposal, plans, specifications, addenda, form of contract and contract bond, and special provisions, and that he/she has inspected in detail the site of the proposed work, and that he/she has familiarized themselves with all of the local conditions affecting the contract and the detailed requirements of construction, and understands that in making this bid proposal he/she waives all right to plead any misunderstanding regarding the same.
4. **EXECUTION OF CONTRACT AND CONTRACT BOND.** The undersigned bidder further agrees to execute a contract for this work and present the same to the department within fifteen (15) days after the contract has been mailed to him/her. The undersigned further agrees that he/she and his/her surety will execute and present within fifteen (15) days after the contract has been mailed to him/her contract bond satisfactory to and in the form prescribed by the Department of Transportation, in the penal sum of the full amount of the contract, or as specified in the special provisions, guaranteeing the faithful performance of the work in accordance with the terms of the contract.
5. **PROPOSAL GUARANTY.** Accompanying this proposal is either a bid bond on the department form, executed by a corporate surety company satisfactory to the department, or a proposal guaranty check consisting of a bank cashier's check or a properly certified check for not less than 5 per cent of the amount bid or for the amount specified in the following schedule:

<u>Amount of Bid</u>		<u>Proposal Guaranty</u>	<u>Amount of Bid</u>		<u>Proposal Guaranty</u>
Up to	\$5,000	\$150	\$2,000,000	to	\$3,000,000
\$5,000	to	\$300	\$3,000,000	to	\$5,000,000
\$10,000	to	\$1,000	\$5,000,000	to	\$7,500,000
\$50,000	to	\$3,000	\$7,500,000	to	\$10,000,000
\$100,000	to	\$5,000	\$10,000,000	to	\$15,000,000
\$150,000	to	\$7,500	\$15,000,000	to	\$20,000,000
\$250,000	to	\$12,500	\$20,000,000	to	\$25,000,000
\$500,000	to	\$25,000	\$25,000,000	to	\$30,000,000
\$1,000,000	to	\$50,000	\$30,000,000	to	\$35,000,000
\$1,500,000	to	\$75,000	over		\$35,000,000

Bank cashier's checks or properly certified checks accompanying proposals will be made payable to the Treasurer, State of Illinois.

If a combination bid is submitted, the proposal guaranties which accompany the individual proposals making up the combination will be considered as also covering the combination bid.

The amount of the proposal guaranty check is _____ \$(_____). If this proposal is accepted and the undersigned will fail to execute contract bond as required herein, it is hereby agreed that the amount of the proposal guaranty will become the property of the State of Illinois, and shall be considered as payment of damages due to delay and other causes suffered by the State because of the failure to execute said contract and contract bond; otherwise, the bid bond will become void or the proposal guaranty check will be returned to the undersigned.

Attach Cashier's Check or Certified Check Here

In the event that one proposal guaranty check is intended to cover two or more proposals, the amount must be equal to the sum of the proposal guaranties which would be required for each individual proposal. If the guaranty check is placed in another proposal, state below where it may be found.

The proposal guaranty check will be found in the proposal for:

Item _____

Airport _____

Mark the proposal cover sheet as to the type of proposal guaranty submitted.

RETURN WITH BID

6. **COMBINATION BIDS.** The undersigned bidder further agrees that if awarded the contract for the sections contained in the following combination, he/she will perform the work in accordance with the requirements of each individual contract comprising the combination bid specified in the schedule below, and that the combination bid shall be prorated against each section in proportion to the bid submitted for the same. If an error is found to exist in the gross sum bid for one or more of the individual sections included in a combination, the combination bid shall be corrected as provided in the specifications.

When a combination bid is submitted, the schedule below must be completed in each proposal comprising the combination.

If alternate bids are submitted for one or more of the sections comprising the combination, a combination bid must be submitted for each alternate.

Schedule of Combination Bids

Combination No.	Sections Included in Combination	Combination Bid	
		Dollars	Cents

7. **SCHEDULE OF PRICES.** The undersigned bidder submits herewith, in accordance with the rules and instructions, a schedule of prices for the items of work for which bids are sought. The unit prices bid are in U.S. dollars and cents, and all extensions and summations have been made. The bidder understands that the quantities appearing in the bid schedule are approximate and are provided for the purpose of obtaining a gross sum for the comparison of bids. If there is an error in the extension of the unit prices, the unit prices will govern. Payment to the contractor awarded the contract will be made only for actual quantities of work performed and accepted or materials furnished according to the contract. The scheduled quantities of work to be done and materials to be furnished may be increased, decreased or omitted as provided elsewhere in the contract.
8. **AUTHORITY TO DO BUSINESS IN ILLINOIS.** Section 20-43 of the Illinois Procurement Code (the Code) (30 ILCS 500/20-43) provides that a person (other than an individual acting as a sole proprietor) must be a legal entity authorized to transact business or conduct affairs in the State of Illinois prior to submitting the bid.
9. **EXECUTION OF CONTRACT.** The Department of Transportation will, in accordance with the rules governing Department procurements, execute the contract and shall be the sole entity having the authority to accept performance and make payments under the contract. Execution of the contract by the Chief Procurement Officer (CPO) or the State Purchasing Officer (SPO) is for approval of the procurement process and execution of the contract by the Department. Neither the CPO nor the SPO shall be responsible for administration of the contract or determinations respecting performance or payment there under except as otherwise permitted in the Code
10. **The services of a subcontractor will be used.**
- Check box Yes
- Check box No

For known subcontractors with subcontracts with an annual value of more than \$50,000, the contract shall include their name, address, general type of work to be performed, and the dollar allocation for each subcontractor. (30 ILCS 500/20-120)

STATE JOB #- - - -

ILLINOIS DEPARTMENT OF TRANSPORTATION
 SCHEDULE OF PRICES
 CONTRACT NUMBER - QU022

ECMS002 DTGECM03 ECMR003 PAGE 1
 RUN DATE - 06/22/16
 RUN TIME - 223804

COUNTY NAME	CODE	DIST	AIRPORT NAME	FED PROJECT	ILL PROJECT
ROCK ISLAND	161	02	QUAD CITY INTERNATIONAL	3-17-0068-XX	ML-I -4531

ITEM NUMBER	PAY ITEM DESCRIPTION	UNIT OF MEASURE	QUANTITY	UNIT PRICE		TOTAL PRICE	
				DOLLARS	CENTS	DOLLARS	CTS
AR110550	SPLIT DUCT	L.F.	550.000 X		=		
AR150520	MOBILIZATION	L.S.	1.000 X		=		
AR152410	UNCLASSIFIED EXCAVATION	C.Y.	16,000.000 X		=		
AR152531	EXPLORATION TRENCH	L.F.	80.000 X		=		
AR152540	SOIL STABILIZATION FABRIC	S.Y.	15,850.000 X		=		
AR156510	SILT FENCE	L.F.	4,750.000 X		=		
AR156511	DITCH CHECK	EACH	20.000 X		=		
AR156520	INLET PROTECTION	EACH	18.000 X		=		
AR208515	POROUS GRANULAR EMBANKMENT	C.Y.	1,610.000 X		=		
AR209608	CRUSHED AGG. BASE COURSE - 8"	S.Y.	15,850.000 X		=		
AR401610	BITUMINOUS SURFACE COURSE	TON	1,280.000 X		=		
AR401900	REMOVE BITUMINOUS PAVEMENT	S.Y.	1,050.000 X		=		
AR403610	BITUMINOUS BASE COURSE	TON	2,140.000 X		=		
AR602510	BITUMINOUS PRIME COAT	GAL.	2,850.000 X		=		
AR603510	BITUMINOUS TACK COAT	GAL.	1,500.000 X		=		

QUAD CITY INTERNATIONAL
 ROCK ISLAND

ILLINOIS DEPARTMENT OF TRANSPORTATION
 SCHEDULE OF PRICES
 CONTRACT NUMBER - QU022

ECMS002 DTGECM03 ECMR003 PAGE 2
 RUN DATE - 06/22/16
 RUN TIME - 223804

ITEM NUMBER	PAY ITEM DESCRIPTION	UNIT OF MEASURE	QUANTITY	UNIT PRICE		TOTAL PRICE	
				DOLLARS	CENTS	DOLLARS	CTS
AR620520	PAVEMENT MARKING-WATERBORNE	S.F.	7,500.000 X		=		
AR701512	12" RCP, CLASS IV	L.F.	155.000 X		=		
AR701524	24" RCP, CLASS IV	L.F.	190.000 X		=		
AR752412	PRECAST REINFORCED CONC. FES 12"	EACH	4.000 X		=		
AR752424	PRECAST REINFORCED CONC. FES 24"	EACH	4.000 X		=		
AR800890	38"X24" ELLIPTICAL RCP, CL. III	L.F.	81.000 X		=		
AR800891	PREC. REINF. CONC. EL. FES 38"X24	EACH	2.000 X		=		
AR901510	SEEDING	ACRE	9.000 X		=		
AR908510	MULCHING	ACRE	7.300 X		=		
AR908520	EXCELSIOR BLANKET	S.Y.	8,300.000 X		=		
AR910200	ROADWAY SIGN	EACH	8.000 X		=		

TOTAL \$

--	--

NOTE:
 *** PLEASE TURN PAGE FOR IMPORTANT NOTES ***

QUAD CITY INTERNATIONAL
ROCK ISLAND

ILLINOIS DEPARTMENT OF TRANSPORTATION
SCHEDULE OF PRICES
CONTRACT NUMBER - QU022

ECMS002 DTGECM03 ECMR003 PAGE 3
RUN DATE - 06/22/16
RUN TIME - 223804

NOTE:

1. EACH PAY ITEM SHOULD HAVE A UNIT PRICE AND A TOTAL PRICE.
2. THE UNIT PRICE SHALL GOVERN IF NO TOTAL PRICE IS SHOWN OR IF THERE IS A DISCREPANCY BETWEEN THE PRODUCT OF THE UNIT PRICE MULTIPLIED BY THE QUANTITY.
3. IF A UNIT PRICE IS OMITTED, THE TOTAL PRICE WILL BE DIVIDED BY THE QUANTITY IN ORDER TO ESTABLISH A UNIT PRICE.
4. A BID MAY BE DECLARED UNACCEPTABLE IF NEITHER A UNIT PRICE NOR A TOTAL PRICE IS SHOWN.

RETURN WITH BID

STATE REQUIRED ETHICAL STANDARDS GOVERNING CONTRACT PROCUREMENT: ASSURANCES, CERTIFICATIONS AND DISCLOSURES

I. GENERAL

A. Article 50 of the Code establishes the duty of all State CPOs, SPOs, and their designees to maximize the value of the expenditure of public moneys in procuring goods, services, and contracts for the State of Illinois and to act in a manner that maintains the integrity and public trust of State government. In discharging this duty, they are charged by law to use all available information, reasonable efforts, and reasonable actions to protect, safeguard, and maintain the procurement process of the State of Illinois.

B. In order to comply with the provisions of Article 50 and to carry out the duty established therein, all bidders are to adhere to ethical standards established for the procurement process, and to make such assurances, disclosures and certifications required by law. Except as otherwise required in subsection III, paragraphs J-M, by execution of the Proposal Signature Sheet, the bidder indicates that each of the mandated assurances has been read and understood, that each certification is made and understood, and that each disclosure requirement has been understood and completed.

C. In addition to all other remedies provided by law, failure to comply with any assurance, failure to make any disclosure or the making of a false certification shall be grounds for the CPO to void the contract, and may result in the suspension or debarment of the bidder or subcontractor. If a false certification is made by a subcontractor, the contractor's submitted bid and the executed contract may not be declared void unless the contractor refuses to terminate the subcontract upon the States' request after a finding that the subcontractor's certification was false.

I acknowledge, understand and accept these terms and conditions.

II. ASSURANCES

The assurances hereinafter made by the bidder are each a material representation of fact upon which reliance is placed should the Department enter into the contract with the bidder.

A. Conflicts of Interest

Section 50-13. Conflicts of Interest.

(a) Prohibition. It is unlawful for any person holding an elective office in this State, holding a seat in the General Assembly, or appointed to or employed in any of the offices or agencies of state government and who receives compensation for such employment in excess of 60% of the salary of the Governor of the State of Illinois, or who is an officer or employee of the Capital Development Board or the Illinois Toll Highway Authority, or who is the spouse or minor child of any such person to have or acquire any contract, or any direct pecuniary interest in any contract therein, whether for stationery, printing, paper, or any services, materials, or supplies, that will be wholly or partially satisfied by the payment of funds appropriated by the General Assembly of the State of Illinois or in any contract of the Capital Development Board or the Illinois Toll Highway Authority.

(b) Interests. It is unlawful for any firm, partnership, association or corporation, in which any person listed in subsection (a) is entitled to receive (i) more than 7 1/2% of the total distributable income or (ii) an amount in excess of the salary of the Governor, to have or acquire any such contract or direct pecuniary interest therein.

(c) Combined interests. It is unlawful for any firm, partnership, association, or corporation, in which any person listed in subsection (a) together with his or her spouse or minor children is entitled to receive (i) more than 15%, in the aggregate, of the total distributable income or (ii) an amount in excess of 2 times the salary of the Governor, to have or acquire any such contract or direct pecuniary interest therein.

(d) Securities. Nothing in this Section invalidates the provisions of any bond or other security previously offered or to be offered for sale or sold by or for the State of Illinois.

(e) Prior interests. This Section does not affect the validity of any contract made between the State and an officer or employee of the State or member of the General Assembly, his or her spouse, minor child or any combination of those persons if that contract was in existence before his or her election or employment as an officer, member, or employee. The contract is voidable, however, if it cannot be completed within 365 calendar days after the officer, member, or employee takes office or is employed. The current salary of the Governor is \$177,412.00. Sixty percent of the salary is \$106,447.20.

RETURN WITH BID

The bidder assures the Department that the award and execution of the contract would not cause a violation of Section 50-13, or that an effective exemption has been issued by the Board of Ethics to any individual subject to the Section 50-13 prohibitions pursuant to the provisions of Section 50-20 of the Code and Executive Order Number 3 (1998). Information concerning the exemption process is available from the Department upon request.

B. Negotiations

Section 50-15. Negotiations.

It is unlawful for any person employed in or on a continual contractual relationship with any of the offices or agencies of State government to participate in contract negotiations on behalf of that office or agency with any firm, partnership, association, or corporation with whom that person has a contract for future employment or is negotiating concerning possible future employment.

The bidder assures the Department that the award and execution of the contract would not cause a violation of Section 50-15, and that the bidder has no knowledge of any facts relevant to the kinds of acts prohibited therein.

C. Inducements

Section 50-25. Inducement.

Any person who offers or pays any money or other valuable thing to any person to induce him or her not to provide a submission to a vendor portal or to bid for a State contract or as recompense for not having bid on a State contract is guilty of a Class 4 felony. Any person who accepts any money or other valuable thing for not bidding for a State contract, not making a submission to a vendor portal or who withholds a bid or submission to a vendor portal in consideration of the promise for the payment of money or other valuable thing is guilty of a Class 4 felony.

The bidder assures the Department that the award and execution of the contract would not cause a violation of Section 50-25, and that the bidder has no knowledge of any facts relevant to the kinds of acts prohibited therein.

D. Revolving Door Prohibition

Section 50-30. Revolving door prohibition.

CPOs, SPOs, procurement compliance monitors, their designees whose principal duties are directly related to State procurement, and executive officers confirmed by the Senate are expressly prohibited for a period of 2 years after terminating an affected position from engaging in any procurement activity relating to the State agency most recently employing them in an affected position for a period of at least 6 months. The prohibition includes, but is not limited to: lobbying the procurement process; specifying; bidding; proposing bid, proposal, or contract documents; on their own behalf or on behalf of any firm, partnership, association, or corporation. This Section applies only to persons who terminate an affected position on or after January 15, 1999.

The bidder assures the Department that the award and execution of the contract would not cause a violation of Section 50-30, and that the bidder has no knowledge of any facts relevant to the kinds of acts prohibited therein.

E. Reporting Anticompetitive Practices

Section 50-40. Reporting anticompetitive practices.

When, for any reason, any vendor, bidder, contractor, CPO, SPO, designee, elected official, or State employee suspects collusion or other anticompetitive practice among any bidders, offers, contractors, proposers, or employees of the State, a notice of the relevant facts shall be transmitted to the Attorney General and the CPO.

The bidder assures the Department that it has not failed to report any relevant facts concerning the practices addressed in Section 50-40 which may involve the contract for which the bid or submission to a vendor portal is submitted.

F. Confidentiality

Section 50-45. Confidentiality.

Any CPO, SPO, designee, or executive officer who willfully uses or allows the use of specifications, competitive bid documents, proprietary competitive information, proposals, contracts, or selection information to compromise the fairness or integrity of the procurement, bidding, or contract process shall be subject to immediate dismissal, regardless of the Personnel code, any contract, or any collective bargaining agreement, and may in addition be subject to criminal prosecution.

The bidder assures the Department that it has no knowledge of any fact relevant to the practices addressed in Section 50-45 which may involve the contract for which the bid is submitted.

RETURN WITH BID

G. Insider Information

Section 50-50. Insider information.

It is unlawful for any current or former elected or appointed State official or State employee to knowingly use confidential information available only by virtue of that office or employment for actual or anticipated gain for themselves or another person.

The bidder assures the Department that it has no knowledge of any facts relevant to the practices addressed in Section 50-50 which may involve the contract for which the bid is submitted.

I acknowledge, understand and accept these terms and conditions for the above assurances.

III. CERTIFICATIONS

The certifications hereinafter made by the bidder are each a material representation of fact upon which reliance is placed should the Department enter into the contract with the bidder. Section 50-2 of the Code provides that every person that has entered into a multi-year contract and every subcontractor with a multi-year subcontract shall certify, by July 1 of each fiscal year covered by the contract after the initial fiscal year, to the responsible CPO whether it continues to satisfy the requirements of Article 50 pertaining to the eligibility for a contract award. If a contractor or subcontractor is not able to truthfully certify that it continues to meet all requirements, it shall provide with its certification a detailed explanation of the circumstances leading to the change in certification status. A contractor or subcontractor that makes a false statement material to any given certification required under Article 50 is, in addition to any other penalties or consequences prescribed by law, subject to liability under the Whistleblower Reward and Protection Act for submission of a false claim.

A. Bribery

Section 50-5. Bribery.

(a) Prohibition. No person or business shall be awarded a contract or subcontract under this Code who:

(1) has been convicted under the laws of Illinois or any other state of bribery or attempting to bribe an officer or employee of the State of Illinois or any other state in that officer's or employee's official capacity; or

(2) has made an admission of guilt of that conduct that is a matter of record but has not been prosecuted for that conduct.

(b) Businesses. No business shall be barred from contracting with any unit of State or local government, or subcontracting under such a contract, as a result of a conviction under this Section of any employee or agent of the business if the employee or agent is no longer employed by the business and:

(1) the business has been finally adjudicated not guilty; or

(2) the business demonstrates to the governmental entity with which it seeks to contract, or which is signatory to the contract which the subcontract relates, and that entity finds that the commission of the offense was not authorized, requested, commanded, or performed by a director, officer, or high managerial agent on behalf of the business as provided in paragraph (2) of subsection (a) of Section 5-4 of the Criminal Code of 2012.

(c) Conduct on behalf of business. For purposes of this Section, when an official, agent, or employee of a business committed the bribery or attempted bribery on behalf of the business and in accordance with the direction or authorization of a responsible official of the business, the business shall be chargeable with the conduct.

(d) Certification. Every bid submitted to and contract executed by the State, and every subcontract subject to Section 20-120 of the Code shall contain a certification by the contractor or the subcontractor, respectively, that the contractor or subcontractor is not barred from being awarded a contract or subcontract under this Section and acknowledges that the CPO may declare the related contract void if any certifications required by this Section are false. A contractor who makes a false statement, material to the certification, commits a Class 3 felony.

The contractor or subcontractor certifies that it is not barred from being awarded a contract under Section 50-5.

B. Felons

Section 50-10. Felons.

(a) Unless otherwise provided, no person or business convicted of a felony shall do business with the State of Illinois or any State agency, or enter into a subcontract, from the date of conviction until 5 years after the date of completion of the sentence for that felony, unless no person held responsible by a prosecutorial office for the facts upon which the conviction was based continues to have any involvement with the business.

(b) Certification. Every bid submitted to and contract executed by the State and every subcontract subject to Section 20-120 of the Code and every vendor's submission to a vendor portal shall contain a certification by the bidder or contractor or subcontractor, respectively, that the bidder, contractor, or subcontractor is not barred from being awarded a contract or subcontract under this Section and acknowledges that the CPO may declare the related contract void if any of the certifications required by this Section are false.

RETURN WITH BID

C. Debt Delinquency

Section 50-11 and 50-12. Debt Delinquency.

The contractor or bidder or subcontractor, respectively, certifies that it, or any affiliate, is not barred from being awarded a contract or subcontract under the Code. Section 50-11 prohibits a person from entering into a contract with a State agency, or entering into a subcontract, if it knows or should know that it, or any affiliate, is delinquent in the payment of any debt to the State as defined by the Debt Collection Board. Section 50-12 prohibits a person from entering into a contract with a State agency, or entering into a subcontract, if it, or any affiliate, has failed to collect and remit Illinois Use Tax on all sales of tangible personal property into the State of Illinois in accordance with the provisions of the Illinois Use Tax Act. The bidder or contractor or subcontractor, respectively, further acknowledges that the CPO may declare the related contract void if this certification is false or if the bidder, contractor, or subcontractor, or any affiliate, is determined to be delinquent in the payment of any debt to the State during the term of the contract.

D. Prohibited Bidders, Contractors and Subcontractors

Section 50-10.5 and 50-60(c). Prohibited bidders, contractors and subcontractors.

The bidder or contractor or subcontractor, respectively, certifies in accordance with Section 50-10.5 that no officer, director, partner or other managerial agent of the contracting business has been convicted of a felony under the Sarbanes-Oxley Act of 2002 or a Class 3 or Class 2 felony under the Illinois Securities Law of 1953 or if in violation of Subsection (c) for a period of five years from the date of conviction. Every bid submitted to and contract executed by the State and every subcontract subject to Section 20-120 of the Code shall contain a certification by the bidder, contractor, or subcontractor, respectively, that the bidder, contractor, or subcontractor is not barred from being awarded a contract or subcontract under this Section and acknowledges that the CPO shall declare the related contract void if any of the certifications completed pursuant to this Section are false.

E. Section 42 of the Environmental Protection Act

Section 50-14 Environmental Protection Act violations.

The bidder or contractor or subcontractor, respectively, certifies in accordance with Section 50-14 that the bidder, contractor, or subcontractor, is not barred from being awarded a contract or entering into a subcontract under this Section which prohibits the bidding on or entering into contracts with the State of Illinois or a State agency, or entering into any subcontract, that is subject to the Code by a person or business found by a court or the Pollution Control Board to have committed a willful or knowing violation of Section 42 of the Environmental Protection Act for a period of five years from the date of the order. The bidder or contractor or subcontractor, respectively, acknowledges that the CPO may declare the contract void if this certification is false.

F. Educational Loan

Section 3 of the Educational Loan Default Act, 5 ILCS 385/3

Pursuant to the Educational Loan Default Act, no State agency shall contract with an individual for goods or services if that individual is in default on an educational loan.

The bidder, if an individual as opposed to a corporation, partnership or other form of business organization, certifies that the bidder is not in default on an educational loan as provided in Section 3 of the Act.

G. Bid-Rigging/Bid Rotating

Section 33E-11 of the Criminal Code of 2012, 720 ILCS 5/33E-11

(a) Every bid submitted to and public contract executed pursuant to such bid by the State or a unit of local government shall contain a certification by the prime contractor that the prime contractor is not barred from contracting with any unit of State or local government as a result of a violation of either Section 33E-3 or 33E-4 of this Article.

(b) A contractor who makes a false statement, material to the certification, commits a Class 3 felony.

A violation of Section 33E-3 would be represented by a conviction of the crime of bid-rigging which, in addition to Class 3 felony sentencing, provides that any person convicted of this offense or any similar offense of any state or the United States which contains the same elements as this offense shall be barred for 5 years from the date of conviction from contracting with any unit of State or local government. No corporation shall be barred from contracting with any unit of State or local government as a result of a conviction under this Section of any employee or agent of such corporation if the employee so convicted is no longer employed by the corporation and: (1) it has been finally adjudicated not guilty or (2) if it demonstrates to the governmental entity with which it seeks to contract and that entity finds that the commission of the offense was neither authorized, requested, commanded, nor performed by a director, officer or a high managerial agent in behalf of the corporation.

RETURN WITH BID

The bidder certifies that it is not barred from contracting with the Department by reason of a violation of either Section 33E-3 or Section 33E-4.

H. International Anti-Boycott

Section 5 of the International Anti-Boycott Certification Act provides every contract entered into by the State of Illinois for the manufacture, furnishing, or purchasing of supplies, material, or equipment or for the furnishing of work, labor, or services, in an amount exceeding the threshold for small purchases according to the purchasing laws of this State or \$10,000.00, whichever is less, shall contain certification, as a material condition of the contract, by which the contractor agrees that neither the contractor nor any substantially-owned affiliated company is participating or shall participate in an international boycott in violation of the provisions of the U.S. Export Administration Act of 1979 or the regulations of the U.S. Department of Commerce promulgated under that Act.

The bidder makes the certification set forth in Section 5 of the Act.

I. Drug Free Workplace

The Illinois "Drug Free Workplace Act" applies to this contract and it is necessary to comply with the provisions of the "Act" if the contractor is a corporation, partnership, or other entity (including a sole proprietorship) which has 25 or more employees.

The bidder certifies that if awarded a contract in excess of \$5,000 it will provide a drug free workplace in compliance with the provisions of the Act.

J. Disclosure of Business Operations in Iran

Section 50-36 of the Code provides that each bid, offer, or proposal submitted for a State contract shall include a disclosure of whether or not the Company acting as the bidder, offeror, or proposing entity, or any of its corporate parents or subsidiaries, within the 24 months before submission of the bid, offer, or proposal had business operations that involved contracts with or provision of supplies or services to the Government of Iran, companies in which the Government of Iran has any direct or indirect equity share, consortiums or projects commissioned by the Government of Iran, or companies involved in consortiums or projects commissioned by the Government of Iran and either of the following conditions apply:

- (1) More than 10% of the Company's revenues produced in or assets located in Iran involve oil-related activities or mineral-extraction activities; less than 75% of the Company's revenues produced in or assets located in Iran involve contracts with or provision of oil-related or mineral-extraction products or services to the Government of Iran or a project or consortium created exclusively by that government; and the Company has failed to take substantial action.
- (2) The Company has, on or after August 5, 1996, made an investment of \$20 million or more, or any combination of investments of at least \$10 million each that in the aggregate equals or exceeds \$20 million in any 12-month period, which directly or significantly contributes to the enhancement of Iran's ability to develop petroleum resources of Iran.

The terms "Business operations", "Company", "Mineral-extraction activities", "Oil-related activities", "Petroleum resources", and "Substantial action" are all defined in the Code.

Failure to make the disclosure required by the Code may cause the bid, offer or proposal to be considered not responsive. The disclosure will be considered when evaluating the bid, offer, or proposal or awarding the contract. The name of each Company disclosed as doing business or having done business in Iran will be provided to the State Comptroller.

Check the appropriate statement:

Company has no business operations in Iran to disclose.

Company has business operations in Iran as disclosed on the attached document.

RETURN WITH BID

K. Apprenticeship and Training Certification (Does not apply to federal aid projects)

In accordance with the provisions of Section 30-22 (6) of the Code, the bidder certifies that it is a participant, either as an individual or as part of a group program, in the approved apprenticeship and training programs applicable to each type of work or craft that the bidder will perform with its own forces. The bidder further certifies for work that will be performed by subcontract that each of its subcontractors submitted for approval either (a) is, at the time of such bid, participating in an approved, applicable apprenticeship and training program; or (b) will, prior to commencement of performance of work pursuant to this contract, begin participation in an approved apprenticeship and training program applicable to the work of the subcontract. The Department, at any time before or after award, may require the production of a copy of each applicable Certificate of Registration issued by the United States Department of Labor evidencing such participation by the contractor and any or all of its subcontractors. Applicable apprenticeship and training programs are those that have been approved and registered with the United States Department of Labor. The bidder shall list in the space below, the official name of the program sponsor holding the Certificate of Registration for all of the types of work or crafts in which the bidder is a participant and that will be performed with the bidder's forces. Types of work or craft work that will be subcontracted shall be included and listed as subcontracted work. The list shall also indicate any type of work or craft job category that does not have an applicable apprenticeship or training program. **The bidder is responsible for making a complete report and shall make certain that each type of work or craft job category that will be utilized on the project as reported on the Construction Employee Workforce Projection (Form BC-1256) and returned with the bid is accounted for and listed.**

Additionally, Section 30-22 of the Code requires that the bidder certify that an Illinois office be maintained as the primary place of employment for persons employed for this contract.

_____ **NA-FEDERAL** _____

The requirements of these certifications and disclosures are a material part of the contract, and the contractor shall require these certification provisions to be included in all approved subcontracts. In order to fulfill this requirement, it shall not be necessary that an applicable program sponsor be currently taking or that it will take applications for apprenticeship, training or employment during the performance of the work of this contract.

RETURN WITH BID

L. Political Contributions and Registration with the State Board of Elections.

Sections 20-160 and 50-37 of the Code regulate political contributions from business entities and any affiliated entities or affiliated persons bidding on or contracting with the state. Generally under Section 50-37, any business entity, and any affiliated entity or affiliated person of the business entity, whose current year contracts with all state agencies exceed an awarded value of \$50,000, are prohibited from making any contributions to any political committees established to promote the candidacy of the officeholder responsible for the awarding of the contracts or any other declared candidate for that office for the duration of the term of office of the incumbent officeholder or a period 2 years after the termination of the contract, whichever is longer. Any business entity and affiliated entities or affiliated persons whose state contracts in the current year do not exceed an awarded value of \$50,000, either alone or in combination with contracts not exceeding \$50,000, are prohibited from making any political contributions to any political committee established to promote the candidacy of the officeholder responsible for awarding the pending contract during the period beginning on the date the invitation for bids or request for proposals or any other procurement opportunity is issued and ending on the day after the date of award or selection if the entity was not awarded or selected. Section 20-160 requires certification of registration of affected business entities in accordance with procedures found in Section 9-35 of The Election Code

By submission of a bid, the contractor business entity acknowledges and agrees that it has read and understands Sections 20-160 and 50-37 of the Code, and that it makes the following certification:

The undersigned business entity certifies that it has registered as a business with the State Board of Elections and acknowledges a continuing duty to update the registration in accordance with the above referenced statutes. If the business entity is required to register, the CPO shall verify that it is in compliance on the date the bid or proposal is due. The CPO shall not accept a bid or proposal if the business entity is not in compliance with the registration requirements.

These requirements and compliance with the above referenced statutory sections are a material part of the contract, and any breach thereof shall be cause to void the contract under Section 50-60 of the Code. This provision does not apply to Federal-aid contracts.

M. Lobbyist Disclosure

Section 50-38 of the Code requires that any bidder or offeror on a State contract that hires a person required to register under the Lobbyist Registration Act to assist in obtaining a contract shall:

- (i) Disclose all costs, fees, compensation, reimbursements, and other remunerations paid or to be paid to the lobbyist related to the contract,
- (ii) Not bill or otherwise cause the State of Illinois to pay for any of the lobbyist's costs, fees, compensation, reimbursements, or other remuneration, and
- (iii) Sign a verification certifying that none of the lobbyist's costs, fees, compensation, reimbursements, or other remuneration were billed to the State.

This information, along with all supporting documents, shall be filed with the agency awarding the contract and with the Secretary of State. The CPO shall post this information, together with the contract award notice, in the online Procurement Bulletin.

Pursuant to Subsection (c) of this Section, no person or entity shall retain a person or entity to attempt to influence the outcome of a procurement decision made under the Code for compensation contingent in whole or in part upon the decision or procurement. Any person who violates this subsection is guilty of a business offense and shall be fined not more than \$10,000.

Bidder acknowledges that it is required to disclose the hiring of any person required to register pursuant to the Illinois Lobbyist Registration Act (25 ILCS 170) in connection with this contract.

Bidder has not hired any person required to register pursuant to the Illinois Lobbyist Registration Act in connection with this contract.

Or

Bidder has hired the following persons required to register pursuant to the Illinois Lobbyist Registration Act in connection with the contract:

Name and address of person: _____
All costs, fees, compensation, reimbursements and other remuneration paid to said person: _____

I acknowledge, understand and accept these terms and conditions for the above certifications.

RETURN WITH BID

IV. DISCLOSURES

- A. The disclosures hereinafter made by the bidder are each a material representation of fact upon which reliance is placed should the Department enter into the contract with the bidder. The bidder further certifies that the Department has received the disclosure forms for each bid.

The CPO may void the bid, or contract, respectively, if it is later determined that the bidder or subcontractor rendered a false or erroneous disclosure. A contractor or subcontractor may be suspended or debarred for violations of the Code. Furthermore, the CPO may void the contract and the surety providing the performance bond shall be responsible for completion of the contract.

B. Financial Interests and Conflicts of Interest

1. Section 50-35 of the Code provides that all bids of more than \$50,000 and all submissions to a vendor portal shall be accompanied by disclosure of the financial interests of the bidder. This disclosed information for the successful bidder, will be maintained as public information subject to release by request pursuant to the Freedom of Information Act, filed with the Procurement Policy Board, and shall be incorporated as a material term of the contract. Furthermore, pursuant to Section 5-5, the Procurement Policy Board may review a proposal, bid, or contract and issue a recommendation to void a contract or reject a proposal or bid based on any violation of the Code or the existence of a conflict of interest as provided in subsections (b) and (d) of Section 50-35.

The financial interests to be disclosed shall include ownership or distributive income share that is in excess of 5%, or an amount greater than 60% of the annual salary of the Governor, of the bidding entity or its parent entity, whichever is less, unless the contractor or bidder is a publicly traded entity subject to Federal 10K reporting, in which case it may submit its 10K disclosure in place of the prescribed disclosure. If a bidder is a privately held entity that is exempt from Federal 10K reporting, but has more than 100 shareholders, it may submit the information that Federal 10K companies are required to report, and list the names of any person or entity holding any ownership share that is in excess of 5%. The disclosure shall include the names, addresses, and dollar or proportionate share of ownership of each individual making the disclosure, their instrument of ownership or beneficial relationship, and notice of any potential conflict of interest resulting from the current ownership or beneficial interest of each individual making the disclosure having any of the relationships identified in Section 50-35 and on the disclosure form.

The current annual salary of the Governor is \$177,412.00

In addition, all disclosures shall indicate any other current or pending contracts, proposals, leases, or other ongoing procurement relationships the bidding entity has with any other unit of state government and shall clearly identify the unit and the contract, proposal, lease, or other relationship.

2. Disclosure Forms. Disclosure Form A is attached for use concerning the individuals meeting the above ownership or distributive share requirements. A separate Disclosure Form A must be submitted with the bid for each individual meeting the above requirements. In addition, a second form (Disclosure Form B) provides for the disclosure of current or pending procurement relationships with other (non-IDOT) state agencies and a total ownership certification. **The forms must be included with each bid.**

C. Disclosure Form Instructions

Form A Instructions for Financial Information & Potential Conflicts of Interest

If the bidder is a publicly traded entity subject to Federal 10K reporting, the 10K Report may be submitted to meet the requirements of Form A. If a bidder is a privately held entity that is exempt from Federal 10K reporting, but has more than 100 shareholders, it may submit the information that Federal 10K companies are required to report, and list the names of any individual or entity holding any ownership share that is in excess of 5%. If a bidder is not subject to Federal 10K reporting, the bidder must determine if any individuals are required by law to complete a financial disclosure form. To do this, the bidder should answer each of the following questions. A "YES" answer indicates Form A must be completed. If the answer to each of the following questions is "NO", then the NOT APPLICABLE STATEMENT on Form A must be signed and dated by an individual that is authorized to execute contracts for the bidding company. Note: These questions are for assistance only and are not required to be completed.

1. Does anyone in your organization have a direct or beneficial ownership share of greater than 5% of the bidding entity or parent entity? YES _____ NO _____
2. Does anyone in your organization have a direct or beneficial ownership share of less than 5%, but which has a value greater than 60% of the annual salary of the Governor? YES _____ NO _____
3. Does anyone in your organization receive more than 60% of the annual salary of the Governor of the bidding entity's or parent entity's distributive income? (Note: Distributive income is, for these purposes, any type of distribution of profits. An annual salary is not distributive income.) YES _____ NO _____
4. Does anyone in your organization receive greater than 5% of the bidding entity's or parent entity's total distributive income, but which is less than 60% of the annual salary of the Governor? YES _____ NO _____

(Note: Only one set of forms needs to be completed per individual per bid even if a specific individual would require a yes answer to more than one question.)

A "YES" answer to any of these questions requires the completion of Form A. The bidder must determine each individual in the bidding entity or the bidding entity's parent company that would cause the questions to be answered "Yes". Each form must be signed and dated by an individual that is authorized to execute contracts for your organization. The individual signing can be, but does not have to be, the individual for which the form is being completed. The bidder is responsible for the accuracy of any information provided.

If the answer to each of the above questions is "NO", then the NOT APPLICABLE STATEMENT of Form A must be signed and dated by an individual that is authorized to execute contracts for your company.

RETURN WITH BID

Form B: Instructions for Identifying Other Contracts & Procurement Related Information

Disclosure Form B must be completed for each bid submitted by the bidding entity. *Note: Checking the NOT APPLICABLE STATEMENT on Form A does not allow the bidder to ignore Form B. Form B must be completed, checked, and dated or the bidder may be considered nonresponsive and the bid will not be accepted.*

The Bidder shall identify, by checking Yes or No on Form B, whether it has any pending contracts (including leases), bids, proposals, or other ongoing procurement relationship with any other (non-IDOT) State of Illinois agency. If "No" is checked, the bidder only needs to complete the check box on the bottom of Form B. If "Yes" is checked, the bidder must do one of the following:

Option I: If the bidder did not submit an Affidavit of Availability to obtain authorization to bid, the bidder must list all non-IDOT State of Illinois agency pending contracts, leases, bids, proposals, and other ongoing procurement relationships. These items may be listed on Form B or on an attached sheet(s). Do not include IDOT contracts. Contracts with cities, counties, villages, etc. are not considered State of Illinois agency contracts and are not to be included. Contracts with other State of Illinois agencies such as the Department of Natural Resources or the Capital Development Board must be included. Bidders who submit Affidavits of Availability are suggested to use Option II.

Option II: If the bidder is required and has submitted an Affidavit of Availability in order to obtain authorization to bid, the bidder may write or type "See Affidavit of Availability" which indicates that the Affidavit of Availability is incorporated by reference and includes all non-IDOT State of Illinois agency pending contracts, leases, bids, proposals, and other ongoing procurement relationships. For any contracts that are not covered by the Affidavit of Availability, the bidder must identify them on Form B or on an attached sheet(s). These might be such things as leases.

**ILLINOIS DEPARTMENT
OF TRANSPORTATION**

**Form A
Financial Information &
Potential Conflicts of Interest
Disclosure**

Contractor Name		
Legal Address		
City, State, Zip		
Telephone Number	Email Address	Fax Number (if available)

Disclosure of the information contained in this Form is required by Section 50-35 of the Code (30 ILCS 500). Vendors desiring to enter into a contract with the State of Illinois must disclose the financial information and potential conflict of interest information as specified in this Disclosure Form. This information shall become part of the publicly available contract file. This Form A must be completed for bids in excess of \$50,000, and for all open-ended contracts. **A publicly traded company may submit a 10K disclosure (or equivalent if applicable) in satisfaction of the requirements set forth in Form A. See Disclosure Form Instructions.**

The current salary of the Governor is \$177,412.00.

DISCLOSURE OF FINANCIAL INFORMATION

1. Disclosure of Financial Information. The individual named below has an interest in the BIDDER (or its parent) in terms of ownership or distributive income share in excess of 5%, or an interest which has a value of more than 60% of the annual salary of the Governor. **(Make copies of this form as necessary and attach a separate Disclosure Form A for each individual meeting these requirements)**

FOR INDIVIDUAL (type or print information)
NAME: _____
ADDRESS _____
Type of ownership/distributable income share:
stock _____ sole proprietorship _____ partnership _____ other: (explain on separate sheet)
% or \$ value of ownership/distributable income share: _____

2. Disclosure of Potential Conflicts of Interest. Check "Yes" or "No" to indicate which, if any, of the following potential conflict of interest relationships apply. If the answer to any question is "Yes", please attach additional pages and describe.

(a) State employment, currently or in the previous 3 years, including contractual employment of services. Yes____ No____

If your answer is yes, please answer each of the following questions.

1. Are you currently an officer or employee of either the Capitol Development Board or the Illinois State Toll Highway Authority? Yes____ No____

2. Are you currently appointed to or employed by any agency of the State of Illinois? If you are currently appointed to or employed by any agency of the State of Illinois, and your annual salary exceeds 60% of the annual salary of the Governor, provide the name of the State agency for which you are employed and your annual salary. _____

RETURN WITH BID

3. If you are currently appointed to or employed by any agency of the State of Illinois, and your annual salary exceeds 60% of the annual salary of the Governor, are you entitled to receive (i) more than 7 1/2% of the total distributable income of your firm, partnership, association or corporation, or (ii) an amount in excess of 100% of the annual salary of the Governor? Yes _____ No _____
4. If you are currently appointed to or employed by any agency of the State of Illinois, and your annual salary exceeds 60% of the annual salary of the Governor, are you and your spouse or minor children entitled to receive (i) more than 15 % in the aggregate of the total distributable income of your firm, partnership, association or corporation, or (ii) an amount in excess of two times the salary of the Governor? Yes _____ No _____

(b) State employment of spouse, father, mother, son, or daughter, including contractual employment for services in the previous 2 years. Yes _____ No _____

If your answer is yes, please answer each of the following questions.

1. Is your spouse or any minor children currently an officer or employee of the Capital Development Board or the Illinois State Toll Highway Authority? Yes _____ No _____
2. Is your spouse or any minor children currently appointed to or employed by any agency of the State of Illinois? If your spouse or minor children is/are currently appointed to or employed by any agency of the State of Illinois, and his/her annual salary exceeds 60% of the annual salary of the Governor, provide the name of your spouse and/or minor children, the name of the State agency for which he/she is employed and his/her annual salary. _____
-
3. If your spouse or any minor children is/are currently appointed to or employed by any agency of the State of Illinois, and his/her annual salary exceeds 60% of the annual salary of the Governor, are you entitled to receive (i) more than 7 1/2% of the total distributable income of your firm, partnership, association or corporation, or (ii) an amount in excess of 100% of the annual salary of the Governor? Yes _____ No _____
4. If your spouse or any minor children are currently appointed to or employed by any agency of the State of Illinois, and his/her annual salary exceeds 60% of the annual salary of the Governor, are you and your spouse or minor children entitled to receive (i) more than 15% in the aggregate of the total distributable income of your firm, partnership, association or corporation, or (ii) an amount in excess of two times the salary of the Governor? Yes _____ No _____

(c) Elective status; the holding of elective office of the State of Illinois, the government of the United States, any unit of local government authorized by the Constitution of the State of Illinois or the statutes of the State of Illinois currently or in the previous 3 years. Yes _____ No _____

(d) Relationship to anyone holding elective office currently or in the previous 2 years; spouse, father, mother, son, or daughter Yes _____ No _____

(e) Appointive office; the holding of any appointive government office of the State of Illinois, the United States of America, or any unit of local government authorized by the Constitution of the State of Illinois or the statutes of the State of Illinois, which office entitles the holder to compensation in excess of the expenses incurred in the discharge of that office currently or in the previous 3 years. Yes _____ No _____

(f) Relationship to anyone holding appointive office currently or in the previous 2 years; spouse, father, mother, son, or daughter. Yes _____ No _____

(g) Employment, currently or in the previous 3 years, as or by any registered lobbyist of the State government. Yes _____ No _____

RETURN WITH BID

(h) Relationship to anyone who is or was a registered lobbyist in the previous 2 years; spouse, father, mother, son, or daughter. Yes____ No____

(i) Compensated employment, currently or in the previous 3 years, by any registered election or reelection committee registered with the Secretary of State or any county clerk of the State of Illinois, or any political action committee registered with either the Secretary of State or the Federal Board of Elections
Yes____ No____

(j) Relationship to anyone; spouse, father, mother, son, or daughter; who was a compensated employee in the last 2 years by any registered election or re-election committee registered with the Secretary of State or any county clerk of the State of Illinois, or any political action committee registered with either the Secretary of State or the Federal Board of Elections.
Yes____ No____

3. Communication Disclosure.

Disclose the name and address of each lobbyist and other agent of the bidder or offeror who is not identified in Section 2 of this form, who has communicated, is communicating, or may communicate with any State officer or employee concerning the bid or offer. This disclosure is a continuing obligation and must be promptly supplemented for accuracy throughout the process and throughout the term of the contract. If no person is identified, enter "None" on the line below:

Name and address of person(s): _____

RETURN WITH BID

4. Suspension or Debarment Disclosure. For each of the persons identified under Sections 2 and 3 of this form, disclose whether any of the following has occurred within the previous 10 years: suspension or debarment from contracting with any governmental entity; professional licensure discipline; bankruptcies; adverse civil judgments and administrative findings; and criminal felony convictions. This disclosure is a continuing obligation and must be promptly supplemented for accuracy throughout the procurement process and term of the contract. If no person is identified, enter "None" on the line below:

Name of person(s): _____

Nature of disclosure: _____

APPLICABLE STATEMENT

This Disclosure Form A is submitted on behalf of the INDIVIDUAL named on previous page. Under penalty of perjury, I certify the contents of this disclosure to be true and accurate to the best of my knowledge.

Completed by: _____ Date _____
Signature of Individual or Authorized Officer

NOT APPLICABLE STATEMENT

Under penalty of perjury, I have determined that no individuals associated with this organization meet the criteria that would require the completion of this Form A.

This Disclosure Form A is submitted on behalf of the CONTRACTOR listed on the previous page.

_____ Date _____
Signature of Authorized Officer

The bidder has a continuing obligation to supplement these disclosures under Sec. 50-35 of the Code.

RETURN WITH BID

ILLINOIS DEPARTMENT OF TRANSPORTATION

Form B Other Contracts & Procurement Related Information Disclosure

Contractor Name, Legal Address, City, State, Zip, Telephone Number, Email Address, Fax Number (if available)

Disclosure of the information contained in this Form is required by Section 50-35 of the Code (30 ILCS 500). This information shall become part of the publicly available contract file. This Form B must be completed for all bids.

DISCLOSURE OF OTHER CONTRACTS AND PROCUREMENT RELATED INFORMATION

1. Identifying Other Contracts & Procurement Related Information. The BIDDER shall identify whether it has any pending contracts (including leases), bids, proposals, or other ongoing procurement relationship with any other State of Illinois agency: Yes _____ No _____ If "No" is checked, the bidder only needs to complete the signature box on this page.

2. If "Yes" is checked. Identify each such relationship by showing State of Illinois agency name and other descriptive information such as bid or project number (attach additional pages as necessary). SEE DISCLOSURE FORM INSTRUCTIONS:

THE FOLLOWING STATEMENT MUST BE CHECKED

Signature of Authorized Representative, Date

OWNERSHIP CERTIFICATION

Please certify that the following statement is true if the individuals for all submitted Form A disclosures do not total 100% of ownership.

Any remaining ownership interest is held by individuals receiving less than \$106,447.20 of the bidding entity's or parent entity's distributive income or holding less than a 5% ownership interest.

Yes No N/A (Form A disclosure(s) established 100% ownership)

RETURN WITH BID

SPECIAL NOTICE TO CONTRACTORS

The following requirements of the Illinois Human Rights Act (775 ILCS 5/et seq), and applicable administrative rules, apply:

CONSTRUCTION EMPLOYEE UTILIZATION PROJECTION

- (a) All bidders on construction contracts shall complete and submit, along with and as part of their bids, a Bidder's Employee Utilization Form (Form BC-1256) setting forth a projection and breakdown of the total workforce intended to be hired and/or allocated to such contract work by the bidder including a projection of minority and female employee utilization in all job classifications on the contract project.
- (b) The Department of Transportation shall review the Employee Utilization Form, and workforce projections contained therein, of the contract awardee to determine if such projections reflect an underutilization of minority persons and/or women in any job classification in accordance with the Equal Employment Opportunity Clause and Title 44, Illinois Administrative Code, Section 750.120. If it is determined that the contract awardee's projections reflect an underutilization of minority persons and/or women in any job classification, it shall be advised in writing of the manner in which it is underutilizing and such awardee shall be considered to be in breach of the contract unless, prior to commencement of work on the contract project, it submits revised satisfactory projections or an acceptable written affirmative action plan to correct such underutilization including a specific timetable geared to the completion stages of the contract.
- (c) The Department of Transportation shall provide to the Department of Human Rights a copy of the contract awardee's Employee Utilization Form, a copy of any required written affirmative action plan, and any written correspondence related thereto. The Department of Human Rights may review and revise any action taken by the Department of Transportation with respect to these requirements.

RETURN WITH BID



Contract No. QU022
Quad City International Airport
Moline, Illinois
Rock Island County
Illinois Project No. MLI-4531
AIP Project No. 3-17-0068-XX

PART I. IDENTIFICATION

Dept. of Human Rights # _____ Duration of Project: _____
 Name of Bidder: _____

PART II. WORKFORCE PROJECTION

A. The undersigned bidder has analyzed minority group and female populations, unemployment rates and availability of workers for the location in which this contract work is to be performed, and for the locations from which the bidder recruits employees, and hereby submits the following workforce projection including a projection for minority and female employee utilization in all job categories in the workforce to be allocated to this contract:

TABLE A

TOTAL Workforce Projection for Contract												
JOB CATEGORIES	TOTAL EMPLOYEES		MINORITY EMPLOYEES					TRAINEES				
			BLACK		HISPANIC		*OTHER MINOR.		APPRENTICES		ON THE JOB TRAINEES	
	M	F	M	F	M	F	M	F	M	F	M	F
OFFICIALS (MANAGERS)												
SUPERVISORS												
FOREMEN												
CLERICAL												
EQUIPMENT OPERATORS												
MECHANICS												
TRUCK DRIVERS												
IRONWORKERS												
CARPENTERS												
CEMENT MASONS												
ELECTRICIANS												
PIPEFITTERS, PLUMBERS												
PAINTERS												
LABORERS, SEMI-SKILLED												
LABORERS, UNSKILLED												
TOTAL												

TABLE B

CURRENT EMPLOYEES TO BE ASSIGNED TO CONTRACT			
TOTAL EMPLOYEES		MINORITY EMPLOYEES	
M	F	M	F

TABLE C

TOTAL Training Projection for Contract								
EMPLOYEES IN TRAINING	TOTAL EMPLOYEES		BLACK		HISPANIC		*OTHER MINOR.	
	M	F	M	F	M	F	M	F
APPRENTICES								
ON THE JOB TRAINEES								

FOR DEPARTMENT USE ONLY

* Other minorities are defined as Asians (A) or Native Americans (N).
 Please specify race of each employee shown in Other Minorities column.

BC 1256 (Rev. 12/11/07)

Note: See instructions on page 2

RETURN WITH BID

**Contract No. QU022
Quad City International Airport
Moline, Illinois
Rock Island County
Illinois Project No. MLI-4531
AIP Project No. 3-17-0068-XX**

PART II. WORKFORCE PROJECTION - continued

- B. Included in "Total Employees" under Table A is the total number of **new hires** that would be employed in the event the undersigned bidder is awarded this contract.

The undersigned bidder projects that: (number) _____ new hires would be recruited from the area in which the contract project is located; and/or (number) _____ new hires would be recruited from the area in which the bidder's principal office or base of operation is located.

- C. Included in "Total Employees" under Table A is a projection of numbers of persons to be employed directly by the undersigned bidder as well as a projection of numbers of persons to be employed by subcontractors.

The undersigned bidder estimates that (number) _____ persons will be directly employed by the prime contractor and that (number) _____ persons will be employed by subcontractors.

PART III. AFFIRMATIVE ACTION PLAN

- A. The undersigned bidder understands and agrees that in the event the foregoing minority and female employee utilization projection included under **PART II** is determined to be an underutilization of minority persons or women in any job category, and in the event that the undersigned bidder is awarded this contract, he/she will, prior to commencement of work, develop and submit a written Affirmative Action Plan including a specific timetable (geared to the completion stages of the contract) whereby deficiencies in minority and/or female employee utilization are corrected. Such Affirmative Action Plan will be subject to approval by the contracting agency and the **Illinois Department of Human Rights**.
- B. The undersigned bidder understands and agrees that the minority and female employee utilization projection submitted herein, and the goals and timetable included under an Affirmative Action Plan if required, are deemed to be part of the contract specifications.

Company _____

Telephone Number _____

Address _____

NOTICE REGARDING SIGNATURE

The Bidder's signature on the Proposal Signature Sheet will constitute the signing of this form. The following signature block needs to be completed only if revisions are required.

Signature: _____ Title: _____ Date: _____

Instructions: All tables must include subcontractor personnel in addition to prime contractor personnel.

Table A - Include both the number of employees that would be hired to perform the contract work and the total number currently employed (Table B) that will be allocated to contract work, and include all apprentices and on-the-job trainees. The "Total Employees" column should include all employees including all minorities, apprentices and on-the-job trainees to be employed on the contract work.

Table B - Include all employees currently employed that will be allocated to the contract work including any apprentices and on-the-job trainees currently employed.

Table C - Indicate the racial breakdown of the total apprentices and on-the-job trainees shown in Table A.

RETURN WITH BID

ADDITIONAL FEDERAL REQUIREMENTS

In addition to the Required Contract Provisions for Federally funded airport construction contracts, all bidders make the following certifications.

A. By the execution of this proposal, the signing bidder certifies that the bidding entity has not, either directly or indirectly, entered into any agreement, participated in any collusion, or otherwise taken any action, in restraint of free competitive bidding in connection with the submitted bid. This statement made by the undersigned bidder is true and correct under penalty of perjury under the laws of the United States.

B. CERTIFICATION, EQUAL EMPLOYMENT OPPORTUNITY

1. Have you participated in any previous contracts or subcontracts subject to the equal opportunity clause?
Yes____ No____

2. If your answer is yes, have you filed with the Joint Reporting Committee, the Director of OFCC, any Federal agency, or the former President's Committee on Equal Employment Opportunity, all reports due under the applicable filing requirements of those organizations? Yes____ No____

RETURN WITH BID

**Contract No. QU022
Quad City International Airport
Moline, Illinois
Rock Island County
Illinois Project No. MLI-4531
AIP Project No. 3-17-0068-XX**

PROPOSAL SIGNATURE SHEET

The undersigned bidder hereby makes and submits this bid on the subject Proposal, thereby assuring the Department that all requirements of the Invitation for Bids and rules of the Department have been met, that there is no misunderstanding of the requirements of paragraph 3 of this Proposal, and that the contract will be executed in accordance with the rules of the Department if an award is made on this bid.

Firm Name _____

(IF AN INDIVIDUAL) Signature of Owner _____

Business Address _____

Firm Name _____

By _____

(IF A CO-PARTNERSHIP) Business Address _____

Name and Address of All Members of the Firm:

Corporate Name _____

By _____

(IF A CORPORATION) Signature of Authorized Representative _____

Typed or printed name and title of Authorized Representative _____

(IF A JOINT VENTURE, USE THIS SECTION FOR THE MANAGING PARTY AND THE SECOND PARTY SHOULD SIGN BELOW) Attest _____

Signature _____

Business Address _____

Corporate Name _____

By _____

(IF A JOINT VENTURE) Signature of Authorized Representative _____

Typed or printed name and title of Authorized Representative _____

Attest _____

Signature _____

Business Address _____

If more than two parties are in the joint venture, please attach additional signature sheet



Sponsor _____ Item No. _____

IL Proj. No. _____ AIP Pr. No. _____ Letting Date _____

KNOW ALL MEN BY THESE PRESENTS, That We _____

_____ as PRINCIPAL, and _____

_____ as SURETY, are held jointly, severally and firmly bound unto the SPONSOR identified above, in the penal sum of 5 percent of the total bid price, or for the amount specified in Section 6, Proposal Guaranty of the Proposal Document, whichever is the lesser sum, well and truly to be paid unto said SPONSOR, for the payment of which we bind ourselves, our heirs, executors, administrators, successors and assigns.

THE CONDITION OF THE FOREGOING OBLIGATION IS SUCH, that whereas, the PRINCIPAL has submitted a bid proposal to the SPONSOR through its AGENT, the State of Illinois, Department of Transportation, Division of Aeronautics, for the improvement designated by the Transportation Bulletin Item Number and Letting Date indicated above.

NOW, THEREFORE, if the SPONSOR through its AGENT shall accept the bid proposal of the PRINCIPAL; and if the PRINCIPAL shall, and as specified in the bidding and contract documents, submit a DBE Utilization Plan that is accepted and approved by the AGENT; and if, after the award by AGENT on behalf of SPONSOR, the PRINCIPAL shall enter into a contract in accordance with the terms of the bidding and contract documents, including evidence of the required insurance coverages and providing such bond as specified with good and sufficient surety for the faithful performance of such contract and for the prompt payment of labor and material furnished in the prosecution thereof; or if, in the event of the failure of the PRINCIPAL to make the required DBE submission or to enter into such contract and to give the specified bond, the PRINCIPAL pays to the SPONSOR the difference not to exceed the penalty hereof between the amount specified in the bid proposal and such larger amount for which the SPONSOR may contract with another party to perform the work covered by said bid proposal, then this obligation shall be null and void, otherwise, it shall remain in full force and effect.

IN THE EVENT the SPONSOR acting through its AGENT determines the PRINCIPAL has failed to comply with any requirement as set forth in the preceding paragraph, then SURETY shall pay the penal sum to the SPONSOR within fifteen (15) days of written demand therefor. If SURETY does not make full payment within such period of time, the AGENT may bring an action to collect the amount owed. SURETY is liable to the SPONSOR and to the AGENT for all its expenses, including attorney's fees, incurred in any litigation in which SPONSOR or AGENT prevail either in whole or in part.

In TESTIMONY WHEREOF, the said PRINCIPAL and the said SURETY have caused this instrument to be signed by their respective officers _____ day of _____ A.D., _____ .

PRINCIPAL

SURETY

(Company Name)

(Company Name)

By _____
(Signature & Title)

By: _____
(Signature of Attorney-in-Fact)

Notary Certification for Principal and Surety

STATE OF ILLINOIS,
County of _____

I, _____, a Notary Public in and for said County, do hereby certify that _____ and _____
(Insert names of individuals signing on behalf of PRINCIPAL & SURETY)

who are each personally known to me to be the same persons whose names are subscribed to the foregoing instrument on behalf of PRINCIPAL and SURETY, appeared before me this day in person and acknowledged respectively, that they signed and delivered said instrument as their free and voluntary act for the uses and purposes therein set forth.

Given under my hand and notarial seal this _____ day of _____ A.D. _____

My commission expires _____

Notary Public

In lieu of completing the above section of the Proposal Bid Form, the Principal may file an Electronic Bid Bond. By signing the proposal and marking the check box next to the Signature and Title line below, the Principal is ensuring the identified electronic bid bond has been executed and the Principal and Surety are firmly bound unto the SPONSOR through its AGENT under the conditions of the bid bond as shown above.

Electronic Bid Bond ID# _____

Company / Bidder Name _____

Signature and Title _____



**Division of Highways
Proposal Bid Bond
(Return with Bid)**



Item No. _____

Letting Date _____

KNOW ALL PERSONS BY THESE PRESENTS, _____

as PRINCIPAL, _____

as SURETY, and held jointly, severally and firmly bound unto the STATE OF ILLINOIS in the penal sum of 5 percent of the total bid price, or for the amount specified in the bid proposal under "Proposal Guaranty" in effect on the date of the Invitation for Bids, whichever is the lesser sum, well and truly to be paid unto said STATE OF ILLINOIS, for the payment of which we bind ourselves, our heirs, executors, administrators, successors and assigns.

THE CONDITION OF THE FOREGOING OBLIGATION IS SUCH that whereas, the PRINCIPAL has submitted a bid proposal to the STATE OF ILLINOIS, acting through the Department of Transportation, for the improvement designated by the Transportation Bulletin Item Number and Letting Date indicated above.

NOW, THEREFORE, if the Department shall accept the bid proposal of the PRINCIPAL; and if the PRINCIPAL shall, within the time and as specified in the bidding and contract documents; and if, after award by the Department, the PRINCIPAL shall enter into a contract in accordance with the terms of the bidding and contract documents including evidence of the required insurance coverages and providing such bond as specified with good and sufficient surety for the faithful performance of such contract and for the prompt payment of labor and material furnished in the prosecution thereof; or if, in the event of the failure of the PRINCIPAL to enter into such contract and to give the specified bond, the PRINCIPAL pays to the Department the difference not to exceed the penalty hereof between the amount specified in the bid proposal and such larger amount for which the Department may contract with another party to perform the work covered by said bid proposal, then this obligation shall be null and void, otherwise, it shall remain in full force and effect.

IN THE EVENT the Department determines the PRINCIPAL has failed to comply with any requirement as set forth in the preceding paragraph, then Surety shall pay the penal sum to the Department within fifteen (15) days of written demand therefor. If Surety does not make full payment within such period of time, the Department may bring an action to collect the amount owed. Surety is liable to the Department for all its expenses, including attorney's fees, incurred in any litigation in which it prevails either in whole or in part.

In TESTIMONY WHEREOF, the said PRINCIPAL has caused this instrument to be signed by its officer
_____ day of _____ A.D., _____

In TESTIMONY WHEREOF, the said SURETY has caused this instrument to be signed by its officer
_____ day of _____ A.D., _____

(Company Name)

(Company Name)

By _____
(Signature and Title)

By _____
(Signature of Attorney-in-Fact)

Notary for PRINCIPAL

Notary for SURETY

STATE OF _____
COUNTY OF _____

STATE OF _____
COUNTY OF _____

Signed and attested before me on _____ (date)
by _____
(Name of Notary Public)

Signed and attested before me on _____ (date)
by _____
(Name of Notary Public)

(Seal) _____
(Signature of Notary Public)

(Seal) _____
(Signature of Notary Public)

(Date Commission Expires)

(Date Commission Expires)

In lieu of completing the above section of the Proposal Bid Bond form, the Principal may file an Electronic Bid Bond. By signing the proposal the Principal is ensuring the identified electronic bid bond has been executed and the Principal and Surety are firmly bound unto the State of Illinois under the conditions of the bid bond as shown above.

Electronic Bid Bond ID # _____ Company/Bidder Name _____ Signature and Title _____



(1) Policy

It is public policy that disadvantageded businesses as defined in 49 CFR Part 26 and the Special Provision shall have the maximum opportunity to participate in the performance of contracts financed in whole or in part with Federal or State funds. Consequently the requirements of 49 CFR Part 26 apply to this contract.

(2) Obligation

The contractor agrees to ensure that disadvantageded businesses as defined in 49 CFR Part 26 and the Special Provision have the maximum opportunity to participate in the performance of contracts or subcontracts financed in whole or in part with Federal or State funds. The contractor shall take all necessary and reasonable steps in accordance with 49 CFR Part 26 and the Special Provision to ensure that said businesses have the maximum opportunity to compete for and perform under this contract. The contractor shall not discriminate on the basis of race, color, national origin or sex in the award and performance of contracts.

(3) Project and Bid Identification

Complete the following information concerning the project and bid:

Route Quad City International Airport

Section _____

Project MLI-4531

County Rock Island County

Letting Date July 29, 2016

Contract No. QU022

Letting Item No. 7A

Total Bid _____

Contract DBE Goal 8.0% _____

(Percent) (Dollar Amount)

(4) Assurance

I, acting in my capacity as an officer of the undersigned bidder (or bidders if a joint venture), hereby assure the Department that on this project my company : (check one)

Meets or exceeds contract award goals and has provided documented participation as follows:
 Disadvantaged Business Participation _____ percent

Attached are the signed participation statements, forms SBE 2025, required by the Special Provision evidencing availability and use of each business participating in this plan and assuring that each business will perform a commercially useful function in the work of the contract.

Failed to meet contract award goals and has included good faith effort documentation to meet the goals and that my company has provided participation as follows:

Disadvantaged Business Participation _____ percent

The contract goals should be accordingly modified or waived. Attached is all information required by the Special Provision in support of this request including good faith effort. Also attached are the signed participation statements, forms SBE 2025, required by the Special Provision evidencing availability and use of each business participating in this plan and assuring that each business will perform a commercially useful function in the work of the contract.

_____ Company

By _____

Title _____

Date _____

The "as read" Low Bidder is required to comply with the Special Provision.

Submit only one utilization plan for each project. The utilization plan shall be submitted in accordance with the special provision.

Bureau of Small Business Enterprises
 2300 South Dirksen Parkway
 Springfield, Illinois 62764

Local Let Projects
 Submit forms to the
 Local Agency

The Department of Transportation is requesting disclosure of information that is necessary to accomplish the purpose as outlined under State and Federal law. Disclosure of this information is **REQUIRED**. Failure to provide any information will result in the contract not being awarded. This form has been approved by the State Forms Manager Center.



Subcontractor Registration Number _____

Letting July 29, 2016

Participation Statement

Item No. 7A

(1) Instructions

Contract No. QU022

This form must be completed for each disadvantaged business participating in the Utilization Plan. This form shall be submitted in accordance with the special provision and will be attached to the Utilization Plan form. If additional space is needed complete an additional form for the firm. Trucking participation items; description must list what is anticipated towards goal credit.

(2) Work:

Please indicate: J/V _____ Manufacturer _____ Supplier (60%) _____ Subcontractor _____ Trucking _____

Table with 5 columns: Pay Item No., Description (Anticipated items for trucking)*, Quantity, Unit Price, Total. Includes a Total row at the bottom right.

(3) Partial Payment Items (For any of the above items which are partial pay items)

Description must be sufficient to determine a Commercially Useful Function, specifically describe the work and subcontract dollar amount:

*Applies to trucking only

(4) Commitment

When a DBE is to be a second-tier subcontractor, or if the first-tier DBE subcontractor is going to be subcontracting a portion of its subcontract, it must be clearly indicated on the DBE Participation Statement, and the details of the transaction fully explained.

In the event a DBE subcontractor second-tiers a portion of its subcontract to one or more subcontractors during the work of a contract, the prime must submit a DBE Participation Statement, with the details of the transaction(s) fully explained.

The undersigned certify that the information included herein is true and correct, and that the DBE firm listed below has agreed to perform a commercially useful function in the work of the contract item(s) listed above and to execute a contract with the prime contractor or 1st Tier subcontractor. The undersigned further understand that no changes to this statement may be made without prior approval from the Department's Bureau of Small Business Enterprises and that complete and accurate information regarding actual work performed on this project and the payment therefore must be provided to the Department.

Signature for Contractor __ 1st Tier __ 2nd Tier

Signature for DBE Firm __ 1st Tier __ 2nd Tier

Date _____

Date _____

Contact _____

Contact _____

Title _____

Title _____

Firm Name _____

Firm Name _____

Address _____

Address _____

City/State/Zip _____

City/State/Zip _____

Phone _____

Phone _____

Email Address _____

Email Address _____

The Department of Transportation is requesting disclosure of information that is necessary to accomplish the statutory purpose as outlined under the state and federal law. Disclosure of this information is REQUIRED. Failure to provide any information will result in the contract not being awarded. This form has been approved by the State Forms Management Center.

E _____
WC _____

PROPOSAL ENVELOPE



PROPOSALS

for construction work advertised for bids by the
Illinois Department of Transportation

Item No.	Item No.	Item No.

Submitted By:

Name:
Address:
Phone No.

Bidders should use an IDOT proposal envelope or affix this form to the front of a 10" x 13" envelope for the submittal of bids. If proposals are mailed, they should be enclosed in a second or outer envelope addressed to:

Engineer of Design and Environment - Room 326
Illinois Department of Transportation
2300 South Dirksen Parkway
Springfield, Illinois 62764

NOTICE

Individual bids, including Bid Bond and/or supplemental information if required, should be securely stapled.

CONTRACTOR OFFICE COPY OF CONTRACT SPECIFICATIONS

NOTICE

None of the following material needs to be returned with the bid package unless the special provisions require documentation and/or other information to be submitted.

**Contract No. QU022
Quad City International Airport
Moline, Illinois
Rock Island County
Illinois Project No. MLI-4531
AIP Project No. 3-17-0068-XX**



Illinois Department of Transportation

SUBCONTRACTOR DOCUMENTATION

Public Acts 96-0795, 96-0920, and 97-0895 enacted substantial changes to the provisions of the Code (30 ILCS 500). Among the changes are provisions affecting subcontractors. The Contractor awarded this contract will be required as a material condition of the contract to implement and enforce the contract requirements applicable to subcontractors that entered into a contractual agreement with a total value of \$50,000 or more with a person or entity who has a contract subject to the Code and approved in accordance with Section 80-01 of the Illinois Standard Specifications for Construction of Airports.

If the Contractor seeks approval of subcontractors to perform a portion of the work, and approval is granted by the Department, the Contractor shall provide a copy of the subcontract to the Illinois Department of Transportation's CPO upon request within 15 calendar days after execution of the subcontract.

Financial disclosures required pursuant to Section 50-35 of the Code must be submitted for all applicable subcontractors. The subcontract shall contain the certifications required to be made by subcontractors pursuant to Article 50 of the Code. This Notice to Bidders includes a document incorporating all required subcontractor certifications and disclosures for use by the Contractor in compliance with this mandate. The document is entitled State Required Ethical Standards Governing Subcontractors.

RETURN WITH SUBCONTRACT

STATE ETHICAL STANDARDS GOVERNING SUBCONTRACTORS

Article 50 of the Code establishes the duty of all State CPOs, SPOs, and their designees to maximize the value of the expenditure of public moneys in procuring goods, services, and contracts for the State of Illinois and to act in a manner that maintains the integrity and public trust of State government. In discharging this duty, they are charged by law to use all available information, reasonable efforts, and reasonable actions to protect, safeguard, and maintain the procurement process of the State of Illinois.

The certifications hereinafter made by the subcontractor are each a material representation of fact upon which reliance is placed should the Department approve the subcontractor. The CPO may terminate or void the contract approval if it is later determined that the bidder or subcontractor rendered a false or erroneous certification. If a false certification is made by a subcontractor the contractor's submitted bid and the executed contract may not be declared void unless the contractor refuses to terminate the subcontract upon the State's request after a finding that the subcontractor's certification was false.

Section 50-2 of the Code provides that every person that has entered into a multi-year contract and every subcontractor with a multi-year subcontract shall certify, by July 1 of each fiscal year covered by the contract after the initial fiscal year, to the responsible CPO whether it continues to satisfy the requirements of Article 50 pertaining to the eligibility for a contract award. If a contractor or subcontractor is not able to truthfully certify that it continues to meet all requirements, it shall provide with its certification a detailed explanation of the circumstances leading to the change in certification status. A contractor or subcontractor that makes a false statement material to any given certification required under Article 50 is, in addition to any other penalties or consequences prescribed by law, subject to liability under the Whistleblower Reward and Protection Act for submission of a false claim.

A. Bribery

Section 50-5. Bribery.

(a) Prohibition. No person or business shall be awarded a contract or subcontract under this Code who:

(1) has been convicted under the laws of Illinois or any other state of bribery or attempting to bribe an officer or employee of the State of Illinois or any other state in that officer's or employee's official capacity; or

(2) has made an admission of guilt of that conduct that is a matter of record but has not been prosecuted for that conduct.

(b) Businesses. No business shall be barred from contracting with any unit of State or local government, or subcontracting under such a contract, as a result of a conviction under this Section of any employee or agent of the business if the employee or agent is no longer employed by the business and:

(1) the business has been finally adjudicated not guilty; or

(2) the business demonstrates to the governmental entity with which it seeks to contract, or which is signatory to the contract to which the subcontract relates, and that entity finds that the commission of the offense was not authorized, requested, commanded, or performed by a director, officer, or high managerial agent on behalf of the business as provided in paragraph (2) of subsection (a) of Section 5-4 of the Criminal Code of 2012.

(c) Conduct on behalf of business. For purposes of this Section, when an official, agent, or employee of a business committed the bribery or attempted bribery on behalf of the business and in accordance with the direction or authorization of a responsible official of the business, the business shall be chargeable with the conduct.

(d) Certification. Every bid submitted to and contract executed by the State, and every subcontract subject to Section 20-120 of the Code shall contain a certification by the contractor or the subcontractor, respectively, that the contractor or subcontractor is not barred from being awarded a contract or subcontract under this Section and acknowledges that the CPO may declare the related contract void if any certifications required by this Section are false. A contractor who makes a false statement, material to the certification, commits a Class 3 felony.

The contractor or subcontractor certifies that it is not barred from being awarded a contract under Section 50-5.

B. Felons

Section 50-10. Felons.

(a.) Unless otherwise provided, no person or business convicted of a felony shall do business with the State of Illinois or any State agency, or enter into a subcontract, from the date of conviction until 5 years after the date of completion of the sentence for that felony, unless no person held responsible by a prosecutorial office for the facts upon which the conviction was based continues to have any involvement with the business.

(b.) Certification. Every bid submitted to and contract executed by the State and every subcontract subject to Section 20-120 of the Code shall contain a certification by the bidder or contractor or subcontractor, respectively, that the bidder, contractor, or subcontractor is not barred from being awarded a contract or subcontract under this Section and acknowledges that the CPO may declare the related contract void if any of the certifications required by this Section are false.

RETURN WITH SUBCONTRACT

C. Debt Delinquency

Section 50-11 and 50-12. Debt Delinquency.

The contractor or bidder or subcontractor, respectively, certifies that it, or any affiliate, is not barred from being awarded a contract or subcontract under the Code. Section 50-11 prohibits a person from entering into a contract with a State agency, or entering into a subcontract, if it knows or should know that it, or any affiliate, is delinquent in the payment of any debt to the State as defined by the Debt Collection Board. Section 50-12 prohibits a person from entering into a contract with a State agency, or entering into a subcontract, if it, or any affiliate, has failed to collect and remit Illinois Use Tax on all sales of tangible personal property into the State of Illinois in accordance with the provisions of the Illinois Use Tax Act. The bidder or contractor or subcontractor, respectively, further acknowledges that the CPO may declare the related contract void if this certification is false or if the bidder, contractor, or subcontractor, or any affiliate, is determined to be delinquent in the payment of any debt to the State during the term of the contract.

D. Prohibited Bidders, Contractors and Subcontractors

Section 50-10.5 and 50-60(c). Prohibited bidders, contractors and subcontractors.

The bidder or contractor or subcontractor, respectively, certifies in accordance with 30 ILCS 500/50-10.5 that no officer, director, partner or other managerial agent of the contracting business has been convicted of a felony under the Sarbanes-Oxley Act of 2002 or a Class 3 or Class 2 felony under the Illinois Securities Law of 1953 or if in violation of Subsection (c) for a period of five years from the date of conviction. Every bid submitted to and contract executed by the State and every subcontract subject to Section 20-120 of the Code shall contain a certification by the bidder, contractor, or subcontractor, respectively, that the bidder, contractor, or subcontractor is not barred from being awarded a contract or subcontract under this Section and acknowledges that the CPO shall declare the related contract void if any of the certifications completed pursuant to this Section are false.

E. Section 42 of the Environmental Protection Act

The bidder or contractor or subcontractor, respectively, certifies in accordance with 30 ILCS 500/50-14 that the bidder, contractor, or subcontractor, is not barred from being awarded a contract or entering into a subcontract under this Section which prohibits the bidding on or entering into contracts with the State of Illinois or a State agency, or entering into any subcontract, that is subject to the Code by a person or business found by a court or the Pollution Control Board to have committed a willful or knowing violation of Section 42 of the Environmental Protection Act for a period of five years from the date of the order. The bidder or contractor or subcontractor, respectively, acknowledges that the CPO may declare the contract void if this certification is false.

The undersigned, on behalf of the subcontracting company, has read and understands the above certifications and makes the certifications as required by law.

<hr style="border: none; border-top: 1px solid black; margin-bottom: 5px;"/> <p style="text-align: center;">Name of Subcontracting Company</p> <hr style="border: none; border-top: 1px solid black; margin-top: 20px;"/>		
Authorized Officer	Date	

RETURN WITH SUBCONTRACT

SUBCONTRACTOR DISCLOSURES

I. DISCLOSURES

- A. The disclosures hereinafter made by the subcontractor are each a material representation of fact upon which reliance is placed. The subcontractor further certifies that the Department has received the disclosure forms for each subcontract.

The CPO may void the bid, contract, or subcontract, respectively, if it is later determined that the bidder or subcontractor rendered a false or erroneous disclosure. A contractor or subcontractor may be suspended or debarred for violations of the Code. Furthermore, CPO may void the contract.

B. Financial Interests and Conflicts of Interest

1. Section 50-35 of the Code provides that all subcontracts with a total value of \$50,000 or more from subcontractors identified in Section 20-120 of the Code shall be accompanied by disclosure of the financial interests of the subcontractor. This disclosed information for the subcontractor, will be maintained as public information subject to release by request pursuant to the Freedom of Information Act, filed with the Procurement Policy Board, and shall be incorporated as a material term of the Prime Contractor's contract. Furthermore, pursuant to this Section, the Procurement Policy Board may recommend to allow or void a contract or subcontract based on a potential conflict of interest.

The financial interests to be disclosed shall include ownership or distributive income share that is in excess of 5%, or an amount greater than 60% of the annual salary of the Governor, of the subcontracting entity or its parent entity, whichever is less, unless the subcontractor is a publicly traded entity subject to Federal 10K reporting, in which case it may submit its 10K disclosure in place of the prescribed disclosure. If a subcontractor is a privately held entity that is exempt from Federal 10K reporting, but has more than 100 shareholders, it may submit the information that Federal 10K companies are required to report, and list the names of any individual or entity holding any ownership share that is in excess of 5%. The disclosure shall include the names, addresses, and dollar or proportionate share of ownership of each Individual making the disclosure, their instrument of ownership or beneficial relationship, and notice of any potential conflict of interest resulting from the current ownership or beneficial interest of each individual making the disclosure having any of the relationships identified in Section 50-35 and on the disclosure form.

The current annual salary of the Governor is \$177,412.00.

In addition, all disclosures shall indicate any other current or pending contracts, subcontracts, proposals, leases, or other ongoing procurement relationships the subcontracting entity has with any other unit of state government and shall clearly identify the unit and the contract, subcontract, proposal, lease, or other relationship.

2. Disclosure Forms. Disclosure Form A is attached for use concerning the individuals meeting the above ownership or distributive share requirements. A separate Disclosure Form A must be submitted with the bid for each individual meeting the above requirements. In addition, a second form (Disclosure Form B) provides for the disclosure of current or pending procurement relationships with other (non-IDOT) state agencies and a total ownership certification. **The forms must be included with each bid.**

C. Disclosure Form Instructions

Form A Instructions for Financial Information & Potential Conflicts of Interest

If the subcontractor is a publicly traded entity subject to Federal 10K reporting, the 10K Report may be submitted to meet the requirements of Form A. If a subcontractor is a privately held entity that is exempt from Federal 10K reporting, but has more than 100 shareholders, it may submit the information that Federal 10K companies are required to report, and list the names of any individual or entity holding any ownership share that is in excess of 5%. If a subcontractor is not subject to Federal 10K reporting, the subcontractor must determine if any individuals are required by law to complete a financial disclosure form. To do this, the subcontractor should answer each of the following questions. A "YES" answer indicates Form A must be completed. If the answer to each of the following questions is "NO", then the NOT APPLICABLE STATEMENT on the second page of Form A must be signed and dated by an individual that is authorized to execute contracts for the subcontracting company. Note: These questions are for assistance only and are not required to be completed.

1. Does anyone in your organization have a direct or beneficial ownership share of greater than 5% of the bidding entity or parent entity?
YES _____ NO _____
2. Does anyone in your organization have a direct or beneficial ownership share of less than 5%, but which has a value greater than 60% of the annual salary of the Governor? YES _____ NO _____
3. Does anyone in your organization receive more than 60% of the annual salary of the Governor of the subcontracting entity's or parent entity's distributive income? (Note: Distributive income is, for these purposes, any type of distribution of profits. An annual salary is not distributive income.) YES _____ NO _____
4. Does anyone in your organization receive greater than 5% of the subcontracting entity's or parent entity's total distributive income, but which is less than 60% of the annual salary of the Governor? YES _____ NO _____

(Note: Only one set of forms needs to be completed per individual per subcontract even if a specific individual would require a yes answer to more than one question.)

A "YES" answer to any of these questions requires the completion of Form A. The subcontractor must determine each individual in the subcontracting entity or the subcontracting entity's parent company that would cause the questions to be answered "Yes". Each form must be signed and dated by an individual that is authorized to execute contracts for your organization. The individual signing can be, but does not have to be, the individual for which the form is being completed. The subcontractor is responsible for the accuracy of any information provided.

If the answer to each of the above questions is "NO", then the NOT APPLICABLE STATEMENT on page 2 of Form A must be signed and dated by an individual that is authorized to execute contracts for your company.

RETURN WITH SUBCONTRACT

Form B: Instructions for Identifying Other Contracts & Procurement Related Information

Disclosure Form B must be completed for each subcontract submitted by the subcontracting entity. *Note: Checking the NOT APPLICABLE STATEMENT on Form A does not allow the subcontractor to ignore Form B. Form B must be completed, checked, and dated or the subcontract will not be approved.*

The Subcontractor shall identify, by checking Yes or No on Form B, whether it has any pending contracts, subcontracts, leases, bids, proposals, or other ongoing procurement relationship with any other (non-IDOT) State of Illinois agency. If "No" is checked, the subcontractor only needs to complete the check box on the bottom of Form B. If "Yes" is checked, the subcontractor must list all non-IDOT State of Illinois agency pending contracts, subcontracts, leases, bids, proposals, and other ongoing procurement relationships. These items may be listed on Form B or on an attached sheet(s). Contracts with cities, counties, villages, etc. are not considered State of Illinois agency contracts and are not to be included. Contracts or subcontracts with other State of Illinois agencies such as the Department of Natural Resources or the Capital Development Board must be included.

ILLINOIS DEPARTMENT OF TRANSPORTATION

Form A Subcontractor: Financial Information & Potential Conflicts of Interest Disclosure

Form with fields: Subcontractor Name, Legal Address, City, State, Zip, Telephone Number, Email Address, Fax Number (if available)

Disclosure of the information contained in this Form is required by Section 50-35 of the Code (30 ILCS 500). Subcontractors desiring to enter into a subcontract of a State of Illinois contract must disclose the financial information and potential conflict of interest information as specified in this Disclosure Form.

The current annual salary of the Governor is \$177,412.00.

DISCLOSURE OF FINANCIAL INFORMATION

1. Disclosure of Financial Information. The individual named below has an interest in the SUBCONTRACTOR (or its parent) in terms of ownership or distributive income share in excess of 5%, or an interest which has a value of more than 60% of the annual salary of the Governor.

FOR INDIVIDUAL (type or print information) NAME: ADDRESS Type of ownership/distributable income share: stock sole proprietorship Partnership other: (explain on separate sheet): % or \$ value of ownership/distributable income share:

2. Disclosure of Potential Conflicts of Interest. Check "Yes" or "No" to indicate which, if any, of the following potential conflict of interest relationships apply. If the answer to any question is "Yes", please attach additional pages and describe.

(a) State employment, currently or in the previous 3 years, including contractual employment of services. Yes No

If your answer is yes, please answer each of the following questions.

- 1. Are you currently an officer or employee of either the Capitol Development Board or the Illinois State Toll Highway Authority? Yes No
2. Are you currently appointed to or employed by any agency of the State of Illinois? If you are currently appointed to or employed by any agency of the State of Illinois, and your annual salary exceeds 60% of the annual salary of the Governor, provide the name the State agency for which you are employed and your annual salary

RETURN WITH SUBCONTRACT

- 3. If you are currently appointed to or employed by any agency of the State of Illinois, and your annual salary exceeds 60% of the annual salary of the Governor, are you entitled to receive (i) more than 7 1/2% of the total distributable income of your firm, partnership, association or corporation, or (ii) an amount in excess of 100% of the annual salary of the Governor? Yes _____ No _____
- 4. If you are currently appointed to or employed by any agency of the State of Illinois, and your annual salary exceeds 60% of the annual salary of the Governor, are you and your spouse or minor children entitled to receive (i) more than 15 % in the aggregate of the total distributable income of your firm, partnership, association or corporation, or (ii) an amount in excess of two times the salary of the Governor? Yes _____ No _____

(b) State employment of spouse, father, mother, son, or daughter, including contractual employment services in the previous 2 years. Yes _____ No _____

If your answer is yes, please answer each of the following questions.

- 1. Is your spouse or any minor children currently an officer or employee of the Capitol Development Board or the Illinois State Toll Highway Authority? Yes _____ No _____
- 2. Is your spouse or any minor children currently appointed to or employed by any agency of the State of Illinois? If your spouse or minor children is/are currently appointed to or employed by any agency of the State of Illinois, and his/her annual salary exceeds 60% of the annual salary of the Governor, provide the name of your spouse and/or minor children, the name of the State agency for which he/she is employed and his/her annual salary. _____
- 3. If your spouse or any minor children is/are currently appointed to or employed by any agency of the State of Illinois, and his/her annual salary exceeds 60% of the annual salary of the Governor, are you entitled to receive (i) more than 7 1/2% of the total distributable income of your firm, partnership, association or corporation, or (ii) an amount in excess of the salary of the Governor? Yes _____ No _____
- 4. If your spouse or any minor children are currently appointed to or employed by any agency of the State of Illinois, and his/her annual salary exceeds 60% of the annual salary of the Governor, are you and your spouse or minor children entitled to receive (i) more than 15 % in the aggregate of the total distributable income of your firm, partnership, association or corporation, or (ii) an amount in excess of 2 times the salary of the Governor? Yes _____ No _____

(c) Elective status; the holding of elective office of the State of Illinois, the government of the United States, any unit of local government authorized by the Constitution of the State of Illinois or the statutes of the State of Illinois currently or in the previous 3 years. Yes _____ No _____

(d) Relationship to anyone holding elective office currently or in the previous 2 years; spouse, father, mother, son, or daughter. Yes _____ No _____

(e) Appointive office; the holding of any appointive government office of the State of Illinois, the United States of America, or any unit of local government authorized by the Constitution of the State of Illinois or the statutes of the State of Illinois, which office entitles the holder to compensation in excess of the expenses incurred in the discharge of that office currently or in the previous 3 years. Yes _____ No _____

(f) Relationship to anyone holding appointive office currently or in the previous 2 years; spouse, father, mother, son, or daughter. Yes _____ No _____

(g) Employment, currently or in the previous 3 years, as or by any registered lobbyist of the State government. Yes _____ No _____

RETURN WITH SUBCONTRACT

(h) Relationship to anyone who is or was a registered lobbyist in the previous 2 years; spouse, father, mother, son, or daughter. Yes _____ No _____

(i) Compensated employment, currently or in the previous 3 years, by any registered election or reelection committee registered with the Secretary of State or any county clerk of the State of Illinois, or any political action committee registered with either the Secretary of State or the Federal Board of Elections. Yes _____ No _____

(j) Relationship to anyone; spouse, father, mother, son, or daughter; who was a compensated employee in the last 2 years by any registered election or re-election committee registered with the Secretary of State or any county clerk of the State of Illinois, or any political action committee registered with either the Secretary of State or the Federal Board of Elections. Yes _____ No _____

3. Communication Disclosure.

Disclose the name and address of each lobbyist and other agent of the bidder or offeror who is not identified in Section 2 of this form, who has communicated, is communicating, or may communicate with any State officer or employee concerning the bid or offer. This disclosure is a continuing obligation and must be promptly supplemented for accuracy throughout the process and throughout the term of the contract. If no person is identified, enter "None" on the line below:

Name and address of person(s): _____

RETURN WITH SUBCONTRACT

4. Suspension or Debarment Disclosure. For each of the persons identified under Sections 2 and 3 of this form, disclose whether any of the following has occurred within the previous 10 years: suspension or debarment from contracting with any governmental entity; professional licensure discipline; bankruptcies; adverse civil judgments and administrative findings; and criminal felony convictions. This disclosure is a continuing obligation and must be promptly supplemented for accuracy throughout the procurement process and term of the contract. If no person is identified, enter "None" on the line below:

Name of person(s): _____

Nature of disclosure: _____

APPLICABLE STATEMENT

This Disclosure Form A is submitted on behalf of the INDIVIDUAL named on previous page. Under penalty of perjury, I certify the contents of this disclosure to be true and accurate to the best of my knowledge.

Completed by:

Signature of Individual or Authorized Officer

Date

NOT APPLICABLE STATEMENT

Under penalty of perjury, I have determined that no individuals associated with this organization meet the criteria that would require the completion of this Form A.

This Disclosure Form A is submitted on behalf of the SUBCONTRACTOR listed on the previous page.

Signature of Authorized Officer

Date

RETURN WITH SUBCONTRACT

ILLINOIS DEPARTMENT OF TRANSPORTATION

Form B Subcontractor: Other Contracts & Procurement Related Information Disclosure

Form with fields: Subcontractor Name, Legal Address, City, State, Zip, Telephone Number, Email Address, Fax Number (if available)

Disclosure of the information contained in this Form is required by Section 50-35 of the Code (30 ILCS 500). This information shall become part of the publicly available contract file. This Form B must be completed for subcontracts with a total value of \$50,000 or more, from subcontractors identified in Section 20-120 of the Code, and for all open-ended contracts.

DISCLOSURE OF OTHER CONTRACTS, SUBCONTRACTS, AND PROCUREMENT RELATED INFORMATION

1. Identifying Other Contracts & Procurement Related Information. The SUBCONTRACTOR shall identify whether it has any pending contracts, subcontracts, including leases, bids, proposals, or other ongoing procurement relationship with any other State of Illinois agency: Yes _____ No _____ If "No" is checked, the subcontractor only needs to complete the signature box on the this page.

2. If "Yes" is checked. Identify each such relationship by showing State of Illinois agency name and other descriptive information such as bid or project number (attach additional pages as necessary). SEE DISCLOSURE FORM INSTRUCTIONS:

THE FOLLOWING STATEMENT MUST BE CHECKED

Signature box with fields: Signature of Authorized Officer, Date

OWNERSHIP CERTIFICATION

Please certify that the following statement is true if the individuals for all submitted Form A disclosures do not total 100% of ownership.

Any remaining ownership interest is held by individuals receiving less than \$106,447.20 of the bidding entity's or parent entity's distributive income or holding less than a 5% ownership interest.

Yes No N/A (Form A disclosure(s) established 100% ownership)



NOTICE TO BIDDERS

1. **TIME AND PLACE OF OPENING BIDS.** Sealed proposals for the improvement described herein will be received by the Department of Transportation. Electronic bids are to be submitted to the electronic bidding system (iCX-Integrated Contractors Exchange). Paper-based bids are to be submitted to the Chief Procurement Officer for the Department of Transportation in care of the Chief Contracts Official at the Harry R. Hanley Building, 2300 South Dirksen Parkway in Springfield, Illinois until 10:00 a.m., July 29, 2016. All bids will be gathered, sorted, publicly opened and read in the auditorium at the Department of Transportation's Harry R. Hanley Building shortly after 10:00 a.m.

2. **DESCRIPTION OF WORK.** The proposed improvement is identified and advertised for bids in the Invitation for Bids as:

**Contract No. QU022
Quad City International Airport
Moline, Illinois
Rock Island County
Illinois Project No. MLI-4531
AIP Project No. 3-17-0068-XX**

Construct Northwest Service Road – Phase 1

3. **INSTRUCTIONS TO BIDDERS.**

(a) This Notice, the invitation for bids, proposal and letter of award shall, together with all other documents in accordance with Article 10-18 of the Illinois Standard Specifications for Construction of Airports, become part of the contract. Bidders are cautioned to read and examine carefully all documents, to make all required inspections, and to inquire or seek explanation of the same prior to submission of a bid.

(b) State law, and, if the work is to be paid wholly or in part with Federal-aid funds, Federal law requires the bidder to make various certifications as a part of the proposal and contract. By execution and submission of the proposal, the bidder makes the certification contained therein. A false or fraudulent certification shall, in addition to all other remedies provided by law, be a breach of contract and may result in termination of the contract.

4. **AWARD CRITERIA AND REJECTION OF BIDS.** This contract will be awarded within 60 calendar days to the lowest responsive and responsible bidder considering conformity with the terms and conditions established by the Department in the proposal and contract documents. The issuance of plans and proposal forms for bidding based upon a prequalification rating shall not be the sole determinant of responsibility. The Department reserves the right to determine responsibility at the time of award, to reject any or all proposals, to readvertise the proposed improvement, and to waive technicalities.

5. **PRE-BID CONFERENCE.** N/A

6. **DISADVANTAGED BUSINESS POLICY.** The DBE goal for this contract is 8.0%.

7. **SPECIFICATIONS AND DRAWINGS.** The work shall be done in accordance with the Illinois Standard Specifications for Construction of Airports, the Illinois Division of Aeronautics Supplemental Specifications and Recurring Special Provisions, the Special Provisions dated June 3, 2016 and the Construction Plans dated June 3, 2016 as approved by the Department of Transportation, Division of Aeronautics.

8. BIDDING REQUIREMENTS AND BASIS OF AWARD. When alternates are included in the proposal, the following shall apply:

a. Additive Alternates

(1) Bidders must submit a bid for the Base Bid and for all Additive Alternates.

(2) Award of this contract will be made to the lowest responsible qualified bidder computed as follows:

The lowest aggregate amount of (i) the Base Bid plus (ii) any Additive Alternate(s) which the Department elects to award.

The Department may elect not to award any Additive Alternates. In that case, award will be to the lowest responsible qualified bidder of the Base Bid.

b. Optional Alternates

(1) Bidders must submit a bid for the Base Bid and for either Alternate A or Alternate B or for both Alternate A and Alternate B.

(2) Award of this contract will be made to the lowest responsible qualified bidder computed as follows:

The lower of the aggregate of either (i) the Base Bid plus Alternate A or (ii) the Base Bid plus Alternate B.

9. CONTRACT TIME. The Contractor shall complete all work within the specified contract time. Any calendar day extension beyond the specified contract time must be fully justified, requested by the Contractor in writing, and approved by the Engineer, or be subject to liquidated damages.

The contract time for this contract is 68 calendar days.

10. INDEPENDENT WEIGHT CHECKS. The Department reserves the right to conduct random unannounced independent weight checks on any delivery for bituminous, aggregate or other pay item for which the method of measurement for payment is based on weight. The weight checks will be accomplished by selecting, at random, a loaded truck and obtaining a loaded and empty weight on an independent scale. In addition, the department may perform random weight checks by obtaining loaded and empty truck weights on portable scales operated by department personnel.

11. GOOD FAITH COMPLIANCE. The Illinois Department of Transportation has made a good faith effort to include all statements, requirements, and other language required by federal and state law and by various offices within federal and state governments whether that language is required by law or not. If anything of this nature has been left out or if additional language etc. is later required, the bidder/contractor shall cooperate fully with the Department to modify the contract or bid documents to correct the deficiency. If the change results in increased operational costs, the Department shall reimburse the contractor for such costs as it may find to be reasonable.

By Order of the
Illinois Department of Transportation

Randall S. Blankenhorn
Secretary of Transportation

ILLINOIS DEPARTMENT OF TRANSPORTATION
DIVISION OF AERONAUTICS

REQUIRED CONTRACT PROVISIONS FOR STATE FUNDED AIRPORT CONSTRUCTION PROJECTS

The following provisions are State of Illinois requirements and are in addition to the REQUIRED CONTRACT PROVISIONS FOR AIRPORT IMPROVEMENT PROGRAM AND FOR OBLIGATED SPONSORS

DISADVANTAGED BUSINESS POLICY

NOTICE: This proposal contains the special provision entitled “Disadvantaged Business Participation.” Inclusion of this Special Provision in this contract satisfies the obligations of the Department of Transportation under federal law as implemented by 49 CFR 23 and under the Illinois “Minority and Female Business Enterprise Act.”

POLICY: It is public policy that the businesses defined in 49 CFR Part 23 shall have the maximum opportunity to participate in the performance of contracts financed in whole or in part with State or Federal funds. Consequently, the requirements of 49 CFR Part 23 apply to this contract.

OBLIGATION: The Contractor agrees to ensure that the businesses defined in 49 CFR Part 23 have the maximum opportunity to participate in the performance of this contract. In this regard, the Contractor shall take all necessary and reasonable steps, in accordance with 49 CFR Part 23, to ensure that the said businesses have the maximum opportunity to compete for and perform portions of this contract. The Contractor shall not discriminate on the basis of race, color, national origin, or sex in the selection and retention of subcontractors, including procurement of materials and leases of equipment.

The Contractor shall include the above Policy and Obligation statements of this Special Provision in every subcontract, including procurement of materials and leases of equipment.

DBE/WBE CONTRACTOR FINANCE PROGRAM: On contracts where a loan has been obtained through the DBE/WBE Contractor Finance Program, the Contractor shall cooperate with the Department by making all payments due to the DBE/WBE Contractor by means of a two-payee check payable to the Lender (Bank) and the Borrower (DBE/WBE Contractor).

BREACH OF CONTRACT: Failure to carry out the requirements set forth above and in the Special Provision shall constitute a breach of contract and may result in termination of the contract or liquidated damages as provided in the special provision.

SPECIAL PROVISION FOR DISADVANTAGED BUSINESS ENTERPRISE PARTICIPATION (BDE)

Effective: September 1, 2000

Revised: July 2, 2016

FEDERAL OBLIGATION. The Department of Transportation, as a recipient of federal financial assistance, is required to take all necessary and reasonable steps to ensure nondiscrimination in the award and administration of contracts. Consequently, the federal regulatory provisions of 49 CFR Part 26 apply to this contract concerning the utilization of disadvantaged business enterprises. For the purposes of this Special Provision, a disadvantaged business enterprise (DBE) means a business certified by the Department in accordance with the requirements of 49 CFR Part 26 and listed in the Illinois Unified Certification Program (IL UCP) DBE Directory.

STATE OBLIGATION. This Special Provision will also be used by the Department to satisfy the requirements of the Business Enterprise for Minorities, Females, and Persons with Disabilities Act, 30 ILCS 575. When this Special Provision is used to satisfy state law requirements on 100 percent state-funded contracts, the federal government has no involvement in such contracts (not a federal-aid contract) and no responsibility to oversee the implementation of this Special Provision by the Department on those contracts. DBE participation on 100 percent state-funded contracts will not be credited toward fulfilling the Department’s annual overall DBE goal required by the US Department of Transportation to comply with the federal DBE program requirements.

CONTRACTOR ASSURANCE. The Contractor makes the following assurance and agrees to include the assurance in each subcontract that the Contractor signs with a subcontractor.

The Contractor, subrecipient, or subcontractor shall not discriminate on the basis of race, color, national origin, or sex in the performance of this contract. The Contractor shall carry out applicable requirements of 49 CFR Part 26 in the award and administration of contracts funded in whole or in part with federal or state funds. Failure by the Contractor to carry out these requirements is a material breach of this contract, which may result in the termination of this contract or such other remedy as the recipient deems appropriate, which may include, but is not limited to:

- (a) Withholding progress payments;
- (b) Assessing sanctions;
- (c) Liquidated damages; and/or
- (d) Disqualifying the Contractor from future bidding as non-responsible.

OVERALL GOAL SET FOR THE DEPARTMENT. As a requirement of compliance with 49 CFR Part 26, the Department has set an overall goal for DBE participation in its federally assisted contracts. That goal applies to all federal-aid funds the Department will expend in its federally assisted contracts for the subject reporting fiscal year. The Department is required to make a good faith effort to achieve the overall goal. The dollar amount paid to all approved DBE companies performing work called for in this contract is eligible to be credited toward fulfillment of the Department's overall goal.

CONTRACT GOAL TO BE ACHIEVED BY THE CONTRACTOR. This contract includes a specific DBE utilization goal established by the Department. The goal has been included because the Department has determined that the work of this contract has subcontracting opportunities that may be suitable for performance by DBE companies. The determination is based on an assessment of the type of work, the location of the work, and the availability of DBE companies to do a part of the work. The assessment indicates that, in the absence of unlawful discrimination, and in an arena of fair and open competition, DBE companies can be expected to perform 8.0% of the work. This percentage is set as the DBE participation goal for this contract. Consequently, in addition to the other award criteria established for this contract, the Department will only award this contract to a bidder who makes a good faith effort to meet this goal of DBE participation in the performance of the work. A bidder makes a good faith effort for award consideration if either of the following is done in accordance with the procedures set for in this Special Provision:

- (a) The bidder documents that enough DBE participation has been obtained to meet the goal or,
- (b) The bidder documents that a good faith effort has been made to meet the goal, even though the effort did not succeed in obtaining enough DBE participation to meet the goal.

DBE LOCATOR REFERENCES. Bidders shall consult the IL UCP DBE Directory as a reference source for DBE-certified companies. In addition, the Department maintains a letting and item specific DBE locator information system whereby DBE companies can register their interest in providing quotes on particular bid items advertised for letting. Information concerning DBE companies willing to quote work for particular contracts may be obtained by contacting the Department's Bureau of Small Business Enterprises at telephone number (217) 785-4611, or by visiting the Department's website at:
<http://www.idot.illinois.gov/doing-business/certifications/disadvantaged-business-enterprise-certification/il-ucp-directory/index>.

BIDDING PROCEDURES. Compliance with this Special Provision is required prior to the award of the contract and the failure of the low bidder to comply will render the bid not responsive.

In order to assure the timely award of the contract, the low bidder shall submit:

- (a) The bidder shall submit a DBE Utilization Plan on completed Department forms SBE 2025 and 2026.
 - (1) The final Utilization Plan must be submitted within five calendar days after the date of the letting in accordance with subsection (a)(2) of Bidding Procedures.
 - (2) To meet the five day requirement, the bidder may send the Utilization Plan electronically by scanning and sending to DOT.DBE.UP@illinois.gov or faxing to (217) 785-1524. The subject line must include the bid Item Number and the Letting date. The Utilization Plan should be sent as one .pdf file, rather than multiple files and emails for the same Item Number. It is the responsibility of the bidder to obtain confirmation of email or fax delivery.

Alternatively, the Utilization Plan may be sent by certified mail or delivery service within the five calendar day period. If a question arises concerning the mailing date of a Utilization Plan, the mailing date will be established by the U.S. Postal Service postmark on the certified mail receipt from the U.S. Postal Service or the receipt issued by a delivery service when the Utilization Plan is received by the Department. It is the responsibility of the bidder to ensure the postmark or receipt date is affixed within the five days if the bidder intends to rely upon mailing or delivery to satisfy the submission day requirement. The Utilization Plan is to be submitted to:

Illinois Department of Transportation
Bureau of Small Business Enterprises
Contract Compliance Section
2300 South Dirksen Parkway, Room 319
Springfield, Illinois 62764

The Department will not accept a Utilization Plan if it does not meet the five day submittal requirement and the bid will be declared not responsive. In the event the bid is declared not responsive due to a failure to submit a Utilization Plan or failure to comply with the bidding procedures set forth herein, the Department may elect to cause the forfeiture of the penal sum of the bidder's proposal guaranty, and may deny authorization to bid the project if re-advertised for bids. The Department reserves the right to invite any other bidder to submit a Utilization Plan at any time for award consideration.

- (b) The Utilization Plan shall indicate that the bidder either has obtained sufficient DBE participation commitments to meet the contract goal or has not obtained enough DBE participation commitments in spite of a good faith effort to meet the goal. The Utilization Plan shall further provide the name, telephone number, and telefax number of a responsible official of the bidder designated for purposes of notification of Utilization Plan approval or disapproval under the procedures of this Special Provision.

- (c) The Utilization Plan shall include a DBE Participation Commitment Statement, Department form SBE 2025, for each DBE proposed for the performance of work to achieve the contract goal. For bidding purposes, submission of the completed SBE 2025 forms, signed by the DBEs and scanned or faxed to the bidder will be acceptable as long as the original is available and provided upon request. All elements of information indicated on the said form shall be provided, including but not limited to the following:
- (1) The names and addresses of DBE firms that will participate in the contract;
 - (2) A description, including pay item numbers, of the work each DBE will perform;
 - (3) The dollar amount of the participation of each DBE firm participating. The dollar amount of participation for identified work shall specifically state the quantity, unit price, and total subcontract price for the work to be completed by the DBE. If partial pay items are to be performed by the DBE, indicate the portion of each item, a unit price where appropriate and the subcontract price amount;
 - (4) DBE Participation Commitment Statements, form SBE 2025, signed by the bidder and each participating DBE firm documenting the commitment to use the DBE subcontractors whose participation is submitted to meet the contract goal;
 - (5) If the bidder is a joint venture comprised of DBE companies and non-DBE companies, the Utilization Plan must also include a clear identification of the portion of the work to be performed by the DBE partner(s); and,
 - (6) If the contract goal is not met, evidence of good faith efforts; the documentation of good faith efforts must include copies of each DBE and non-DBE subcontractor quote submitted to the bidder when a non-DBE subcontractor is selected over a DBE for work on the contract.

GOOD FAITH EFFORT PROCEDURES. The contract will not be awarded until the Utilization Plan submitted by the apparent successful bidder is approved. All information submitted by the bidder must be complete, accurate and adequately document that enough DBE participation has been obtained or document that good faith efforts of the bidder, in the event enough DBE participation has not been obtained, before the Department will commit to the performance of the contract by the bidder. The Utilization Plan will be approved by the Department if the Utilization Plan documents sufficient commercially useful DBE work to meet the contract goal or the bidder submits sufficient documentation of a good faith effort to meet the contract goal pursuant to 49 CFR Part 26, Appendix A. The Utilization Plan will not be approved by the Department if the Utilization Plan does not document sufficient DBE participation to meet the contract goal unless the apparent successful bidder documented in the Utilization Plan that it made a good faith effort to meet the goal. This means that the bidder must show that all necessary and reasonable steps were taken to achieve the contract goal. Necessary and reasonable steps are those which, by their scope, intensity and appropriateness to the objective, could reasonably be expected to obtain sufficient DBE participation, even if they were not successful. The Department will consider the quality, quantity, and intensity of the kinds of efforts that the bidder has made. Mere *pro forma* efforts, in other words, efforts done as a matter of form, are not good faith efforts; rather, the bidder is expected to have taken genuine efforts that would be reasonably expected of a bidder actively and aggressively trying to obtain DBE participation sufficient to meet the contract goal.

- (a) The following is a list of types of action that the Department will consider as part of the evaluation of the bidder's good faith efforts to obtain participation. These listed factors are not intended to be a mandatory checklist and are not intended to be exhaustive. Other factors or efforts brought to the attention of the Department may be relevant in appropriate cases, and will be considered by the Department.
- (1) Soliciting through all reasonable and available means (e.g. attendance at pre-bid meetings, advertising and/or written notices) the interest of all certified DBE companies that have the capability to perform the work of the contract. The bidder must solicit this interest within sufficient time to allow the DBE companies to respond to the solicitation. The bidder must determine with certainty if the DBE companies are interested by taking appropriate steps to follow up initial solicitations.
 - (2) Selecting portions of the work to be performed by DBE companies in order to increase the likelihood that the DBE goals will be achieved. This includes, where appropriate, breaking out contract work items into economically feasible units to facilitate DBE participation, even when the prime Contractor might otherwise prefer to perform these work items with its own forces.
 - (3) Providing interested DBE companies with adequate information about the plans, specifications, and requirements of the contract in a timely manner to assist them in responding to a solicitation.
 - (4) a. Negotiating in good faith with interested DBE companies. It is the bidder's responsibility to make a portion of the work available to DBE subcontractors and suppliers and to select those portions of the work or material needs consistent with the available DBE subcontractors and suppliers, so as to facilitate DBE participation. Evidence of such negotiation includes the names, addresses, and telephone numbers of DBE companies that were considered; a description of the information provided regarding the plans and specifications for the work selected for subcontracting; and evidence as to why additional agreements could not be reached for DBE companies to perform the work.

- b. A bidder using good business judgment would consider a number of factors in negotiating with subcontractors, including DBE subcontractors, and would take a firm's price and capabilities as well as contract goals into consideration. However, the fact that there may be some additional costs involved in finding and using DBE companies is not in itself sufficient reason for a bidder's failure to meet the contract DBE goal, as long as such costs are reasonable. Also the ability or desire of a bidder to perform the work of a contract with its own organization does not relieve the bidder of the responsibility to make good faith efforts. Bidders are not, however, required to accept higher quotes from DBE companies if the price difference is excessive or unreasonable. In accordance with subsection (c)(6) of the above Bidding Procedures, the documentation of good faith efforts must include copies of each DBE and non-DBE subcontractor quote submitted to the bidder when a non-DBE subcontractor was selected over a DBE for work on the contract.
- (5) Not rejecting DBE companies as being unqualified without sound reasons based on a thorough investigation of their capabilities. The bidder's standing within its industry, membership in specific groups, organizations, or associations and political or social affiliations (for example union vs. non-union employee status) are not legitimate causes for the rejection or non-solicitation of bids in the bidder's efforts to meet the project goal.
 - (6) Making efforts to assist interested DBE companies in obtaining bonding, lines of credit, or insurance as required by the recipient or Contractor.
 - (7) Making efforts to assist interested DBE companies in obtaining necessary equipment, supplies, materials, or related assistance or services.
 - (8) Effectively using the services of available minority/women community organizations; minority/women contractors' groups; local, state, and federal minority/women business assistance offices; and other organizations as allowed on a case-by-case basis to provide assistance in the recruitment and placement of DBE companies.
- (b) If the Department determines that the apparent successful bidder has made a good faith effort to secure the work commitment of DBE companies to meet the contract goal, the Department will award the contract provided that it is otherwise eligible for award. If the Department determines that the bidder has failed to meet the requirements of this Special Provision or that a good faith effort has not been made, the Department will notify the responsible company official designated in the Utilization Plan that the bid is not responsive. The notification shall include a statement of reasons for the determination. If the Utilization Plan is not approved because it is deficient as a technical matter, unless waived by the Department, the bidder will be notified and will be allowed no more than a five calendar day period in order to cure the deficiency.
 - (c) The bidder may request administrative reconsideration of a determination adverse to the bidder within the five working days after the receipt of the notification date of the determination by delivering the request to the Department of Transportation, Bureau of Small Business Enterprises, Contract Compliance Section, 2300 South Dirksen Parkway, Room 319, Springfield, Illinois 62764 (Telefax: (217) 785-1524). Deposit of the request in the United States mail on or before the fifth business day shall not be deemed delivery. The determination shall become final if a request is not made and delivered. A request may provide additional written documentation or argument concerning the issues raised in the determination statement of reasons, provided the documentation and arguments address efforts made prior to submitting the bid. The request will be forwarded to the Department's Reconsideration Officer. The Reconsideration Officer will extend an opportunity to the bidder to meet in person in order to consider all issues of documentation and whether the bidder made a good faith effort to meet the goal. After the review by the Reconsideration Officer, the bidder will be sent a written decision within ten working days after receipt of the request for consideration, explaining the basis for finding that the bidder did or did not meet the goal or make adequate good faith efforts to do so. A final decision by the Reconsideration Officer that a good faith effort was made shall approve the Utilization Plan submitted by the bidder and shall clear the contract for award. A final decision that a good faith effort was not made shall render the bid not responsive.

CALCULATING DBE PARTICIPATION. The Utilization Plan values represent work anticipated to be performed and paid for upon satisfactory completion. The Department is only able to count toward the achievement of the overall goal and the contract goal the value of payments made for the work actually performed by DBE companies. In addition, a DBE must perform a commercially useful function on the contract to be counted. A commercially useful function is generally performed when the DBE is responsible for the work and is carrying out its responsibilities by actually performing, managing, and supervising the work involved. The Department and Contractor are governed by the provisions of 49 CFR Part 26.55(c) on questions of commercially useful functions as it affects the work. Specific counting guidelines are provided in 49 CFR Part 26.55, the provisions of which govern over the summary contained herein.

- (a) DBE as the Contractor: 100 percent goal credit for that portion of the work performed by the DBE's own forces, including the cost of materials and supplies. Work that a DBE subcontracts to a non-DBE does not count toward the DBE goals.
- (b) DBE as a joint venture Contractor: 100 percent goal credit for that portion of the total dollar value of the contract equal to the distinct, clearly defined portion of the work performed by the DBE's own forces.
- (c) DBE as a subcontractor: 100 percent goal credit for the work of the subcontract performed by the DBE's own forces, including the cost of materials and supplies, excluding the purchase of materials and supplies or the lease of equipment by the DBE subcontractor from the prime Contractor or its affiliates. Work that a DBE subcontractor in turn subcontracts to a non-DBE does not count toward the DBE goal.

- (d) DBE as a trucker: 100 percent goal credit for trucking participation provided the DBE is responsible for the management and supervision of the entire trucking operation for which it is responsible. At least one truck owned, operated, licensed, and insured by the DBE must be used on the contract. Credit will be given for the following:
 - (1) The DBE may lease trucks from another DBE firm, including an owner-operator who is certified as a DBE. The DBE who leases trucks from another DBE receives credit for the total value of the transportation services the lessee DBE provides on the contract.
 - (2) The DBE may also lease trucks from a non-DBE firm, including from an owner-operator. The DBE who leases trucks from a non-DBE is entitled to credit only for the fee or commission it receives as a result of the lease arrangement.
- (e) DBE as a material supplier:
 - (1) 60 percent goal credit for the cost of the materials or supplies purchased from a DBE regular dealer.
 - (2) 100 percent goal credit for the cost of materials or supplies obtained from a DBE manufacturer.
 - (3) 100 percent credit for the value of reasonable fees and commissions for the procurement of materials and supplies if not a DBE regular dealer or DBE manufacturer.

CONTRACT COMPLIANCE. Compliance with this Special Provision is an essential part of the contract. The Department is prohibited by federal regulations from crediting the participation of a DBE included in the Utilization Plan toward either the contract goal or the Department's overall goal until the amount to be applied toward the goals has been paid to the DBE. The following administrative procedures and remedies govern the compliance by the Contractor with the contractual obligations established by the Utilization Plan. After approval of the Utilization Plan and award of the contract, the Utilization Plan and individual DBE Participation Statements become part of the contract. If the Contractor did not succeed in obtaining enough DBE participation to achieve the advertised contract goal, and the Utilization Plan was approved and contract awarded based upon a determination of good faith, the total dollar value of DBE work calculated in the approved Utilization Plan as a percentage of the awarded contract value shall become the amended contract goal. All work indicated for performance by an approved DBE shall be performed, managed, and supervised by the DBE executing the DBE Participation Commitment Statement.

- (a) **NO AMENDMENT.** No amendment to the Utilization Plan may be made without prior written approval from the Department's Bureau of Small Business Enterprises. All requests for amendment to the Utilization Plan shall be submitted to the Department of Transportation, Bureau of Small Business Enterprises, Contract Compliance Section, 2300 South Dirksen Parkway, Room 319, Springfield, Illinois 62764. Telephone number (217) 785-4611. Telefax number (217) 785-1524.
- (b) **CHANGES TO WORK.** Any deviation from the DBE condition-of-award or contract plans, specifications, or special provisions must be approved, in writing, by the Department as provided elsewhere in the Contract. The Contractor shall notify affected DBEs in writing of any changes in the scope of work which result in a reduction in the dollar amount condition-of-award to the contract. Where the revision includes work committed to a new DBE subcontractor, not previously involved in the project, then a Request for Approval of Subcontractor, Department form BC 260A or AER 260A, must be signed and submitted. If the commitment of work is in the form of additional tasks assigned to an existing subcontract, then a new Request for Approval of Subcontractor shall not be required. However, the Contractor must document efforts to assure that the existing DBE subcontractor is capable of performing the additional work and has agreed in writing to the change.
- (c) **SUBCONTRACT.** The Contractor must provide DBE subcontracts to IDOT upon request. Subcontractors shall ensure that all lower tier subcontracts or agreements with DBEs to supply labor or materials be performed in accordance with this Special Provision.
- (d) **ALTERNATIVE WORK METHODS.** In addition to the above requirements for reductions in the condition of award, additional requirements apply to the two cases of Contractor-initiated work substitution proposals. Where the contract allows alternate work methods which serve to delete or create underruns in condition of award DBE work, and the Contractor selects that alternate method or, where the Contractor proposes a substitute work method or material that serves to diminish or delete work committed to a DBE and replace it with other work, then the Contractor must demonstrate one of the following:
 - (1) That the replacement work will be performed by the same DBE (as long as the DBE is certified in the respective item of work) in a modification of the condition of award; or
 - (2) That the DBE is aware that its work will be deleted or will experience underruns and has agreed in writing to the change. If this occurs, the Contractor shall substitute other work of equivalent value to a certified DBE or provide documentation of good faith efforts to do so; or
 - (3) That the DBE is not capable of performing the replacement work or has declined to perform the work at a reasonable competitive price. If this occurs, the Contractor shall substitute other work of equivalent value to a certified DBE or provide documentation of good faith efforts to do so.
- (e) **TERMINATION AND REPLACEMENT PROCEDURES.** The Contractor shall not terminate or replace a DBE listed on the approved Utilization Plan, or perform with other forces work designated for a listed DBE except as provided in this Special

Provision. The Contractor shall utilize the specific DBEs listed to perform the work and supply the materials for which each is listed unless the Contractor obtains the Department's written consent as provided in subsection (a) of this part. Unless Department consent is provided for termination of a DBE subcontractor, the Contractor shall not be entitled to any payment for work or material unless it is performed or supplied by the DBE in the Utilization Plan.

As stated above, the Contractor shall not terminate or replace a DBE subcontractor listed in the approved Utilization Plan without prior written consent. This includes, but is not limited to, instances in which the Contractor seeks to perform work originally designated for a DBE subcontractor with its own forces or those of an affiliate, a non-DBE firm, or with another DBE firm. Written consent will be granted only if the Bureau of Small Business Enterprises agrees, for reasons stated in its concurrence document, that the Contractor has good cause to terminate or replace the DBE firm. Before transmitting to the Bureau of Small Business Enterprises any request to terminate and/or substitute a DBE subcontractor, the Contractor shall give notice in writing to the DBE subcontractor, with a copy to the Bureau, of its intent to request to terminate and/or substitute, and the reason for the request. The Contractor shall give the DBE five days to respond to the Contractor's notice. The DBE so notified shall advise the Bureau and the Contractor of the reasons, if any, why it objects to the proposed termination of its subcontract and why the Bureau should not approve the Contractor's action. If required in a particular case as a matter of public necessity, the Bureau may provide a response period shorter than five days.

For purposes of this paragraph, good cause includes the following circumstances:

- (1) The listed DBE subcontractor fails or refuses to execute a written contract;
- (2) The listed DBE subcontractor fails or refuses to perform the work of its subcontract in a way consistent with normal industry standards. Provided, however, that good cause does not exist if the failure or refusal of the DBE subcontractor to perform its work on the subcontract results from the bad faith or discriminatory action of the prime contractor;
- (3) The listed DBE subcontractor fails or refuses to meet the prime Contractor's reasonable, nondiscriminatory bond requirements;
- (4) The listed DBE subcontractor becomes bankrupt, insolvent, or exhibits credit unworthiness;
- (5) The listed DBE subcontractor is ineligible to work on public works projects because of suspension and debarment proceedings pursuant 2 CFR Parts 180, 215 and 1200 or applicable state law.
- (6) You have determined that the listed DBE subcontractor is not a responsible contractor;
- (7) The listed DBE subcontractor voluntarily withdraws from the projects and provides to you written notice of its withdrawal;
- (8) The listed DBE is ineligible to receive DBE credit for the type of work required;
- (9) A DBE owner dies or becomes disabled with the result that the listed DBE subcontractor is unable to complete its work on the contract;
- (10) Other documented good cause that compels the termination of the DBE subcontractor. Provided, that good cause does not exist if the prime Contractor seeks to terminate a DBE it relied upon to obtain the contract so that the prime Contractor can self-perform the work for which the DBE contractor was engaged or so that the prime Contractor can substitute another DBE or non-DBE contractor after contract award.

When a DBE is terminated, or fails to complete its work on the Contract for any reason the Contractor shall make a good faith effort to find another DBE to substitute for the original DBE to perform at least the same amount of work under the contract as the terminated DBE to the extent needed to meet the established Contract goal. The good faith efforts shall be documented by the Contractor. If the Department requests documentation under this provision, the Contractor shall submit the documentation within seven days, which may be extended for an additional seven days if necessary at the request of the Contractor. The Department shall provide a written determination to the Contractor stating whether or not good faith efforts have been demonstrated.

- (f) **PAYMENT RECORDS.** The Contractor shall maintain a record of payments for work performed to the DBE participants. The records shall be made available to the Department for inspection upon request. After the performance of the final item of work or delivery of material by a DBE and final payment therefore to the DBE by the Contractor, but not later than thirty calendar days after payment has been made by the Department to the Contractor for such work or material, the Contractor shall submit a DBE Payment Agreement on Department form SBE 2115 to the Resident Engineer. If full and final payment has not been made to the DBE, the DBE Payment Agreement shall indicate whether a disagreement as to the payment required exists between the Contractor and the DBE or if the Contractor believes that the work has not been satisfactorily completed. If the Contractor does not have the full amount of work indicated in the Utilization Plan performed by the DBE companies indicated in the Utilization Plan and after good faith efforts are reviewed, the Department may deduct from contract payments to the Contractor the amount of the goal not achieved as liquidated and ascertained damages. The Contractor may request an administrative reconsideration of any amount deducted as damages pursuant to subsection (h) of this part.

- (g) **ENFORCEMENT.** The Department reserves the right to withhold payment to the Contractor to enforce the provisions of this Special Provision. Final payment shall not be made on the contract until such time as the Contractor submits sufficient documentation demonstrating achievement of the goal in accordance with this Special Provision or after liquidated damages have been determined and collected.
- (h) **RECONSIDERATION.** Notwithstanding any other provision of the contract, including but not limited to Article 109.09 of the Standard Specifications, the Contractor may request administrative reconsideration of a decision to deduct the amount of the goal not achieved as liquidated damages. A request to reconsider shall be delivered to the Contract Compliance Section and shall be handled and considered in the same manner as set forth in paragraph (c) of "Good Faith Effort Procedures" of this Special Provision, except a final decision that a good faith effort was not made during contract performance to achieve the goal agreed to in the Utilization Plan shall be the final administrative decision of the Department. The result of the reconsideration process is not administratively appealable to the U.S. Department of Transportation.

SPECIAL PROVISION FOR WEEKLY DBE TRUCKING REPORTS (BDE)

Effective: June 2, 2012

Revised: April 2, 2015

The Contractor shall submit a weekly report of Disadvantaged Business Enterprise (DBE) trucks hired by the Contractor or subcontractors (i.e. not owned by the Contractor or subcontractors) that are used for DBE goal credit.

The report shall be submitted to the Resident Engineer on Division of Aeronautics Form "AER 723" within ten business days following the reporting period. The reporting period shall be Monday through Sunday for each week reportable trucking activities occur.

Any costs associated with providing weekly DBE trucking reports shall be considered as included in the contract unit prices bid for the various items of work involved and no additional compensation will be allowed.

SPECIAL PROVISION FOR SUBCONTRACTOR MOBILIZATION PAYMENTS

Revised: April 1, 2011

To account for the preparatory work and the operations necessary for the movement of subcontractor personnel, equipment, supplies, and incidentals to the project site and for all other work or operations that must be performed or costs incurred when beginning work approved for subcontracting according to Section 80-01 of the Standard Specifications, the Contractor shall make a mobilization payment to each subcontractor.

This mobilization payment shall be made at least 14 days prior to the subcontractor starting work. The amount paid shall be equal to 3 percent of the amount of the subcontract reported on form AER 260A submitted for the approval of the subcontractor's work.

The mobilization payment to the subcontractor is an advance payment of the reported amount of the subcontract and is not a payment in addition to the amount of the subcontract; therefore, the amount of the advance payment will be deducted from future progress payments.

This provision shall be incorporated directly or by reference into each subcontract approved by the Department

SPECIAL PROVISION FOR PAYMENTS TO SUBCONTRACTORS

Revised: January 1, 2006

Federal regulations found at 49 CFR §26.29 mandate the Department to establish a contract clause to require Contractors to pay subcontractors for satisfactory performance of their subcontracts and to set the time for such payments.

State law also addresses the timing of payments to be made to subcontractors and material suppliers. Section 7 of the Prompt Payment Act, 30 ILCS 540/7, requires that when a Contractor receives any payment from the Department, the Contractor shall make corresponding, proportional payments to each subcontractor and material supplier performing work or supplying material within 15 calendar days after receipt of the Department payment. Section 7 of the Act further provides that interest in the amount of two percent per month, in addition to the payment due, shall be paid to any subcontractor or material supplier by the Contractor if the payment required by the Act is withheld or delayed without reasonable cause. The Act also provides that the time for payment required and the calculation of any interest due applies to transactions between subcontractors and lower-tier subcontractors and material suppliers throughout the contracting chain.

This Special Provision establishes the required federal contract clause, and adopts the 15 calendar day requirement of the State Prompt Payment Act for purposes of compliance with the federal regulation regarding payments to subcontractors. This contract is subject to the following payment obligations.

When progress payments are made to the Contractor according to Article 90-07 of the Standard Specifications, the Contractor shall make a corresponding payment to each subcontractor and material supplier in proportion to the work satisfactorily completed by each subcontractor and for the material supplied to perform any work of the contract. The proportionate amount of partial payment due to each subcontractor and material supplier throughout the contracting chain shall be determined by the quantities measured or otherwise determined as eligible for payment by the Department and included in the progress payment to the Contractor. Subcontractors and material suppliers shall be paid by the Contractor within 15 calendar days after the receipt of payment from the Department. The

Contractor shall not hold retainage from the subcontractors. These obligations shall also apply to any payments made by subcontractors and material suppliers to their subcontractors and material suppliers; and to all payments made to lower tier subcontractors and material suppliers throughout the contracting chain. Any payment or portion of a payment subject to this provision may only be withheld from the subcontractor or material supplier to whom it is due for reasonable cause.

This Special Provision does not create any rights in favor of any subcontractor or material supplier against the State or authorize any cause of action against the State on account of any payment, nonpayment, delayed payment, or interest claimed by application of the State Prompt Payment Act. The Department will not approve any delay or postponement of the 15 day requirement except for reasonable cause shown after notice and hearing pursuant to Section 7(b) of the State Prompt Payment Act. State law creates other and additional remedies available to any subcontractor or material supplier, regardless of tier, who has not been paid for work properly performed or material furnished. These remedies are a lien against public funds set forth in Section 23(c) of the Mechanics Lien Act, 770 ILCS 60/23(c), and a recovery on the Contractor's payment bond according to the Public Construction Bond Act, 30 ILCS 550.

SPECIAL PROVISION FOR ADDITIONAL STATE REQUIREMENTS FOR FEDERAL-AID CONSTRUCTION CONTRACTS

Effective: February 1, 1969

Revised: April 1, 2015

EQUAL EMPLOYMENT OPPORTUNITY

In the event of the Contractor's noncompliance with the provisions of this Equal Employment Opportunity Clause, the Illinois Human Rights Act, or the Illinois Department of Human Rights Rules and Regulations, the Contractor may be declared ineligible for future contracts or subcontracts with the State of Illinois or any of its political sub-divisions or municipal corporations, and the contract may be cancelled or voided in whole or in part, and such other sanctions or penalties may be imposed or remedies invoked as provided by statute or regulation.

During the performance of this Contract, the Contractor agrees as follows:

(1) That it will not discriminate against any employee or applicant for employment because of race, color, religion, sex, sexual orientation, marital status, order of protection status, national origin or ancestry, citizenship status, age, physical or mental disability unrelated to ability, military status, or an unfavorable discharge from military service; and further that it will examine all job classifications to determine if minority persons or women are underutilized and will take appropriate affirmative action to rectify any such underutilization.

(2) That, if it hires additional employees in order to perform this contract or any portion hereof, it will determine the availability (according to the Illinois Department of Human Rights Rules and Regulations) of minorities and women in the area(s) from which it may reasonably recruit and it will hire for each job classification for which employees are hired in such a way that minorities and women are not underutilized.

(3) That, in all solicitations or advertisements for employees placed by it or on its behalf, it will state that all applicants will be afforded equal opportunity without discrimination because of race, color, religion, sex, sexual orientation, marital status, order of protection status, national origin or ancestry, citizenship status, age, physical or mental disability unrelated to ability, military status or an unfavorable discharge from military service.

(4) That it will send to each labor organization or representative of workers with which it has or is bound by a collective bargaining or other agreement or understanding, a notice advising such labor organization or representative of the Contractor's obligations under the Illinois Human Rights Act and the Illinois Department of Human Rights Rules and Regulations. If any labor organization or representative fails or refuses to cooperate with the Contractor in its efforts to comply with such Act and Rules and Regulations, the Contractor will promptly so notify the Illinois Department of Human Rights and IDOT and will recruit employees from other sources when necessary to fulfill its obligations thereunder.

(5) That it will submit reports as required by the Illinois Department of Human Rights Rules and Regulations, furnish all relevant information as may from time to time be requested by the Illinois Department of Human Rights or IDOT, and in all respects comply with the Illinois Human Rights Act and the Illinois Department of Human Rights Rules and Regulations.

(6) That it will permit access to all relevant books, records, accounts, and work sites by personnel of IDOT and the Illinois Department of Human Rights for purposes of investigation to ascertain compliance with the Illinois Human Rights Act and the Illinois Department of Human Rights Rules and Regulations.

(7) That it will include verbatim or by reference the provisions of this clause in every subcontract it awards under which any portion of the contract obligations are undertaken or assumed, so that the provisions will be binding upon the subcontractor. In the same manner as with other provisions of this contract, the Contractor will be liable for compliance with applicable provisions of this clause by subcontractors; and further it will promptly notify IDOT and the Illinois Department of Human Rights in the event any subcontractor fails or refuses to comply with these provisions. In addition, the Contractor will not utilize any subcontractor declared by the Illinois Human Rights Commission to be ineligible for contracts or subcontracts with the State of Illinois or any of its political subdivisions or municipal corporations.

SPECIAL PROVISION FOR NPDES CERTIFICATION

In accordance with the provisions of the Illinois Environmental Protection Act, the Illinois Pollution Control Board Rules and Regulations (35 Ill. Adm. Code, Subtitle C, Chapter I), and the Clean Water Act, and the regulations thereunder, this certification is required for all construction contracts that will result in the disturbance of one or more acres total land area.

The bidder certifies under penalty of law that he/she understands the terms and conditions of the general National Pollutant Discharge Elimination System (NPDES) permit (ILR100000) that authorizes the storm water discharges associated with industrial activity from the construction site identified as part of this certification.

The Airport Owner or its Agent will:

- 1) prepare, sign and submit the Notice of Intent (NOI)
- 2) conduct site inspections and complete and file the inspection reports
- 3) submit Incidence of Non-Compliance (ION) forms
- 4) submit Notice of Termination (NOT) form

Prior to the issuance of the Notice-to-Proceed, for each erosion control measure identified in the Storm Water Pollution Prevention Plan, the contractor or subcontractor responsible for the control measure(s) must sign the above certification (forms to be provided by the Department).

SPECIAL PROVISION FOR COMPLETION TIME VIA CALENDAR DAYS

It being understood and agreed that the completion within the time limit is an essential part of the contract, the bidder agrees to complete the work within 68 calendar days, unless additional time is granted by the Engineer in accordance with the provisions of the specifications. In case of failure to complete the work on or before the time named herein, or within such extra time as may have been allowed by extensions, the bidder agrees that the Department of Transportation shall withhold from such sum as may be due him/her under the terms of this contract, the costs, as set forth in Section 80-09 Failure to Complete on Time of the Standard Specifications, which costs shall be considered and treated not as a penalty but as damages due to the State from the bidder by reason of the failure of the bidder to complete the work within the time specified in the contract.

State of Illinois
Department of Transportation

SPECIAL PROVISION
FOR
SECTION 80 PROSECUTION AND PROGRESS

This Special Provision amends the provisions of the Standard Specifications for Construction of Airports, adopted April 1, 2012 and shall be construed to be a part thereof, superseding any conflicting provisions thereof applicable to the work under the contract.

80-09 FAILURE TO COMPLETE ON TIME.

DELETE: "See contract documents for current schedule of deductions."

ADD:

Schedule of Deductions for Each Day of Overrun in Contract Time			
Original Contract Amount		Daily Charges	
From More Than	To and Including	Calendar Day	Work Day
\$ 0	\$ 100,000	\$ 475	\$ 675
100,000	500,000	750	1,050
500,000	1,000,000	1,025	1,425
1,000,000	3,000,000	1,275	1,725
3,000,000	6,000,000	1,425	2,000
6,000,000	12,000,000	2,300	3,450
12,000,000	And over	6,775	9,525

State of Illinois
Department of Transportation

SPECIAL PROVISION
FOR
SECTION 90 MEASUREMENT AND PAYMENT

This Special Provision amends the provisions of the Standard Specifications for Construction of Airports, adopted April 1, 2012 and shall be construed to be a part thereof, superseding any conflicting provisions thereof applicable to the work under the contract.

90-07 PARTIAL PAYMENTS.

DELETE: The entire section.

ADD: Partial payments will be made to the Contractor at least once each month as the work progresses. The payments will be based upon estimates, prepared by the Resident Engineer, of the value of the work performed and materials complete and in place in accordance with the contract, plans, and specifications. Such partial payments may also include the delivered actual cost of those materials stockpiled and stored in accordance with the Section 90-08 PAYMENT FOR MATERIALS ON HAND. From the amount of partial payment so determined on Federal-Aid projects, there shall be deducted an amount up to ten percent of the cost of the completed work which shall be retained until all conditions necessary for financial closeout of the project are satisfied. The amount of the estimate approved as due for payment will be vouchered by the Department and presented to the State Comptroller for payment. No amount less than \$1,000.00 will be approved for payment other than the final payment. A final voucher for under \$5.00 shall not be paid except through electronic funds transfer. (15 ILCS 405/9(b-1))

It is understood and agreed that the Contractor shall not be entitled to demand or receive partial payment based on quantities of work in excess of those provided in the proposal or covered by approved change orders, except when such excess quantities have been determined by the Engineer to be a part of the final quantity for the item of work in question.

No partial payment shall bind the Department to the acceptance of any materials or work in place as to quality or quantity. All partial payments are subject to correction at the time of final payment as provided in Section 90-09 ACCEPTANCE AND FINAL PAYMENT.

Progress payments may be reduced by liens filed pursuant to Section 23(c) of the Mechanics Lien Act, 770 ILCS 60/23(c).

If a Contractor or subcontractor has defaulted on a loan issued under the Department's Disadvantaged Business Revolving Loan Program (20 ILCS 2705/2705-610) progress payments may be reduced pursuant to the terms of that loan agreement. In such cases, the amount of the estimate related to the work performed by the Contractor or subcontractor, in default of the loan agreement, will be offset, in whole or in part, and vouchered by the Department to the Working Capital Revolving Fund or designated escrow account. Payment for the work shall be considered as issued and received by the Contractor or subcontractor on the date of the offset voucher. Further, the amount of the offset voucher shall be a credit against the Department's obligation to pay the Contractor, the Contractor's obligation to pay the subcontractor, and the Contractor's or subcontractor's total loan indebtedness to the Department. The offset shall continue until such time as the entire loan indebtedness is satisfied. The Department will notify the Contractor and Fund Control Agent in a timely manner of such offset. The Contractor or subcontractor shall not be entitled to additional payment in consideration of the offset.

In accordance with 49 USC § 47111, the Department will not make payments totaling more than 90 percent of the contract until all conditions necessary for financial closeout of the project are satisfied.

The failure to perform any requirement, obligation, or term of the contract by the Contractor shall be reason for withholding any progress payments until the Department determines that compliance has been achieved.

90-10 TRUST AGREEMENT OPTION.

DELETE: The entire section.



Required Contract Provisions for Airport Improvement Program and for Obligated Sponsors

Requirements	54
1. Required Contract Provisions	54
2. Sponsor Requirements	54
3. Incorporation of Provisions	54
4. Requests for Bids (Advertisement) and Notice to Bidders	54
5. Requirements For All Contracts Entered into by Obligated Sponsors	54
6. Failure to Comply with Provisions	54
7. Applicability Matrix for Contract Provisions	55
APPENDIX A – CONTRACT PROVISIONS	56
A1 ACCESS TO RECORDS AND REPORTS	56
A2 AFFIRMATIVE ACTION REQUIREMENTS	56
A3 BREACH OF CONTRACT TERMS	59
A4 BUY AMERICAN PREFERENCE	59
A5 CIVIL RIGHTS - GENERAL	60
A6 CIVIL RIGHTS – TITLE VI ASSURANCE	61
A7 CLEAN AIR AND WATER POLLUTION CONTROL	64
A8 CONTRACT WORKHOURS AND SAFETY STANDARDS ACT REQUIREMENTS	64
A9 COPELAND “ANTI-KICKBACK” ACT	65
A10 DAVIS-BACON REQUIREMENTS	66
A11 DEBARMENT AND SUSPENSION	69
A12 DISADVANTAGED BUSINESS ENTERPRISE	70
A13 Distracted Driving	71
A14 ENERGY CONSERVATION REQUIREMENTS	72
A15 EQUAL EMPLOYMENT OPPORTUNITY (E.E.O.)	72
A16 FEDERAL FAIR LABOR STANDARDS ACT (FEDERAL MINIMUM WAGE)	75
A17 LOBBYING AND INFLUENCING FEDERAL EMPLOYEES	76
A18 PROHIBITION of SEGREGATED FACILITIES	76
A19 OCCUPATIONAL SAFETY AND HEALTH ACT OF 1970	77
A20 PROCUREMENT OF RECOVERED MATERIALS	77
A21 RIGHT TO INVENTIONS	78
A22 SEISMIC SAFETY	78
A23 TERMINATION OF CONTRACT	79
A24 TRADE RESTRICTION CERTIFICATION	81
A25 VETERAN’S PREFERENCE	82

REQUIREMENTS

1. Required Contract Provisions

Federal laws and regulations require that recipients of federal assistance (Sponsors) include specific contract provisions in certain contracts, requests for proposals, or invitations to bid.

Certain provisions must be included in all sponsor contracts, regardless of *whether or not* the contracts are federally-funded. This requirement was established when a sponsor accepted the Airport Improvement Program (AIP) grant assurances.

To maintain eligibility of their procurement actions, a sponsor must incorporate applicable contract provisions in all federally-assisted procurement and contract documents, including all subcontracts. For purposes of determining requirements for contract provisions, the term **contract** includes subcontracts.

2. Sponsor Requirements

In general, the sponsor must:

- 1) Incorporate applicable contract provisions in each contract funded under AIP;
 - a. Except as noted herein, a sponsor must physically incorporate the text of the provision within the procurement documents.
 - b. Where specifically noted, sponsors may incorporate select provisions by reference provided the sponsor indicates that the reference has the same force and effect as if given in full text.
- 2) Require the contractor (including all subcontractors) to insert these contract provisions in each lower tier contracts (e.g. subcontract or sub-agreement);
- 3) Require the contractor (or subcontractor) to incorporate the applicable requirements of these contract provisions by reference for work done under any purchase orders, rental agreements and other agreements for supplies or services;
- 4) Require that the prime contractor be responsible for compliance with these contract provisions by any subcontractor, lower-tier subcontractor or service provider;
- 5) Verify that any required local or State provision does not conflict with, or alter a Federal law or regulation.

3. Incorporation of Provisions

The statutes and regulations that establish the requirements for contract provisions do not always specify language the sponsor must use to address the requirement. Appendix A of this guide provides information on when a provision or clause has mandatory language that a sponsor must apply. Refer to the subheading *Applicability* for each provision.

Whenever a clause or provision has mandatory text, the sponsor must incorporate the text of the provision without change. The only exception to this restriction is for those instances within the provision text that require the sponsor to insert appropriate information such as name or value. To align with the sponsor's standard contract language, the word "Owner" may also be replaced with "Airport Authority" or their standard method of referring to the sponsor in contracts. Any modification beyond what is specifically permitted is not permitted and may invalidate the clause.

For those provisions that do not have required language, this guidance provides model language acceptable to the FAA in meeting the intent and purpose of the law or regulation. Some sponsors may already have standard procurement language that is equivalent to those Federal provisions that do not have explicit mandatory language. In these cases, sponsors may use their existing standard procurement provision language provided the text meets the intent and purpose of the Federal law or regulation.

Contract clause language must be made available to bidders. The Sponsor does this by including the required language in Requests for Bids, Notices to Bidders, or in the contract.

4. Requests for Bids (Advertisement) and Notice to Bidders

The sponsor may incorporate certain provisions *by reference* in the Request for Bids (the Advertisement) rather than including the entire text of the provision in the Request or Notice to Bidders. The sponsor must incorporate the full text of these provisions within any contract that originates from the procurement action. The provisions that can be incorporated by reference in the Request or Notice are:

- 1) Buy American Preference
- 2) Foreign Trade Restriction
- 3) Davis Bacon
- 4) Affirmative Action
- 5) Government-wide Debarment and Suspension
- 6) Government-wide Requirements for Drug-free Workplace

5. Requirements For All Contracts Entered into by Obligated Sponsors.

A sponsor's acceptance of previous grant assurances obligates them to include certain notifications in all contracts and procurement actions they undertake regardless of funding source. Contracts and agreements fully funded by the sponsor must incorporate those select provisions.

6. Failure to Comply with Provisions

Sponsor failure to incorporate required provisions will jeopardize AIP eligibility of the sponsor's project. Contractor failure to comply with the terms of these contract provisions may be sufficient grounds to:

- 1) Withhold progress payments or final payment;

- 2) Terminate the contract for cause;
- 3) Seek suspension/debarment; or
- 4) Take other action determined to be appropriate by the sponsor or the FAA.

7. Applicability Matrix for Contract Provisions

Table 1 summarizes the applicability of contract provisions based upon the type of contract or agreement. The dollar threshold represents the value at which, when equal to or exceeded, the sponsor must incorporate the provision in their contract or agreement. Supplemental information addressing applicability and use for each provision is located in Appendix A.

Meaning of cell values

- REQD - a provision the sponsor must incorporate in their procurement action.
- Limited –a provision with limited applicability depending on circumstances of the procurement.
- n/a – a provision that is not applicable for that procurement type.

Table 1 – Applicability of Provisions

Provision	Dollar Threshold	Professional Services	Construction	Equipment	Property (Land)	Non-AIP Contracts
a. Access to Records and Reports	\$ 0	REQD	REQD	REQD	REQD	n/a
b. Buy American Preferences	\$ 0	Limited	REQD	REQD	Limited	n/a
c. Civil Rights – General	\$ 0	REQD	REQD	REQD	REQD	REQD
d. Civil Rights - Title VI Assurances	\$ 0	REQD	REQD	REQD	REQD	REQD
(1) Notice - Solicitation	\$ 0	REQD	REQD	REQD	REQD	REQD
(2) Clause - Contracts	\$ 0	REQD	REQD	REQD	REQD	REQD
(3) Clause – Transfer of U.S. Property	\$ 0	n/a	n/a	n/a	REQD	REQD
(4) Clause – Transfer of Real Property	\$ 0	n/a	n/a	n/a	REQD	REQD
(5) Clause - Construct/Use/Access to Real Property	\$ 0	n/a	n/a	n/a	REQD	REQD
(6) List – Pertinent Authorities	\$ 0	REQD	REQD	REQD	REQD	REQD
e. Disadvantaged Business Enterprise	\$ 0	REQD	REQD	REQD	REQD	n/a
f. Energy Conservation Requirements	\$ 0	REQD	REQD	REQD	REQD	n/a
g. Federal Fair Labor Standards Act	\$ 0	REQD	REQD	REQD	REQD	REQD
h. Occupational Safety and Health Act	\$ 0	REQD	REQD	REQD	REQD	REQD
i. Rights to Inventions	\$ 0	Limited	Limited	Limited	n/a	n/a
j. Trade Restriction Certification	\$ 0	REQD	REQD	REQD	REQD	n/a
k. Veteran’s Preference	\$ 0	REQD	REQD	REQD	REQD	n/a
l. Seismic Safety	\$ 0	Limited	Limited	n/a	n/a	n/a
m. Copeland Anti-Kickback	\$ 2,000	Limited	REQD	Limited	Limited	n/a
n. Davis Bacon Requirements	\$ 2,000	Limited	REQD	Limited	Limited	n/a
o. Distracted Driving	\$3,000	REQD	REQD	REQD	REQD	n/a
p. Affirmative Action Requirement	\$10,000	Limited	REQD	Limited	Limited	n/a
q. Equal Employment Opportunity	\$10,000	Limited	REQD	Limited	Limited	n/a
(1) EEO Contract Clause	\$10,000	Limited	REQD	Limited	Limited	n/a
(2) EEO Specification	\$10,000	Limited	REQD	Limited	Limited	n/a
r. Prohibition of Segregated Facilities	\$10,000	Limited	REQD	Limited	Limited	n/a
s. Recovered Materials	\$10,000	Limited	REQD	REQD	Limited	n/a
t. Termination of Contract	\$10,000	REQD	REQD	REQD	REQD	n/a
u. Debarment and Suspension	\$25,000	REQD	REQD	REQD	Limited	n/a
v. Contract Work Hours and Safety Standards	\$100,000	Limited	REQD	Limited	Limited	n/a
w. Lobbying Federal Employees	\$ 100,000	REQD	REQD	REQD	REQD	n/a
x. Breach of Contract	\$150,000	REQD	REQD	REQD	REQD	n/a
y. Clean Air/Water Pollution Control	\$150,000	REQD	REQD	REQD	REQD	n/a

APPENDIX A – CONTRACT PROVISIONS

A1 ACCESS TO RECORDS AND REPORTS

A1.1 SOURCE

2 CFR § 200.333

2 CFR § 200.336

FAA Order 5100.38

A1.2 APPLICABILITY

2 CFR § 200.333 requires a sponsor to retain records pertinent to a Federal award for a period of three years from submission of final closure documents. 2 CFR § 200.336 establishes that sponsors must provide Federal entities the right to access records pertinent to the Federal award. FAA policy extends these requirements to the sponsor's contracts and subcontracts of AIP funded projects.

Contract Types – The sponsor must include this provision in all contracts and subcontracts of AIP funded projects.

Use of Provision – The regulation does not prescribe mandatory language, the following language is acceptable to the FAA and meets the intent of this requirement. If the sponsor uses different language, the sponsor's language must fully satisfy the requirements of part 200.

A1.3 CONTRACT CLAUSE

ACCESS TO RECORDS AND REPORTS

The Contractor must maintain an acceptable cost accounting system. The Contractor agrees to provide the sponsor, the Federal Aviation Administration, and the Comptroller General of the United States or any of their duly authorized representatives, access to any books, documents, papers, and records of the contractor which are directly pertinent to the specific contract for the purpose of making audit, examination, excerpts and transcriptions. The Contractor agrees to maintain all books, records and reports required under this contract for a period of not less than three years after final payment is made and all pending matters are closed.

A2 AFFIRMATIVE ACTION REQUIREMENTS

A2.1 SOURCE

41 CFR part 60-4

Executive Order 11246

A2.2 APPLICABILITY

Minority Participation. Sponsors are required to set goals for minority participation in AIP funded projects. The goals for minority participation depend on Economic Area (EA) and Standard Metropolitan Statistical Area (SMSA) as established in Volume 45 of the Federal Register dated 10/3/80. Page 65984 contains a table of all EAs and SMSAs and the associated minority participation goals.

To find the goals for minority participation, a sponsor must either refer to the Federal Register Notice or to the Department of Labor document, "Technical Assistance Guide for Federal Construction Contractors". EA's and SMSA's cross state boundaries so a sponsor may have to refer to entries for adjacent states to find their project location.

A sponsor must insert the applicable percentage minority goal. Sponsor must not simply insert a reference to the Federal Register Notice.

Female Participation. Executive Order 11246 has set a goal of 6.9% nationally for female participation for all construction contractors. This value does not change per county or state.

Contract Types –

Construction: The sponsor must incorporate this notice in all solicitations for bids or requests for proposals for AIP funded construction work contracts and subcontracts that exceed \$10,000. Construction work means construction, rehabilitation, alteration, conversion, extension, demolition or repair of buildings, highways, or other changes or improvements to real property, including facilities providing utility services. The term also includes the supervision, inspection, and other onsite functions incidental to the actual construction.

Equipment: The sponsor must incorporate this notice in any equipment project exceeding \$10,000 that involves installation of equipment onsite (e.g. electrical vault equipment). This provision does not apply to equipment acquisition projects where the manufacture of the equipment takes place offsite at the vendor plant (e.g. firefighting and snow removal vehicles)

Professional Services: The sponsor must incorporate this notice in any professional service agreement if the professional service agreement includes construction work (as defined above) that exceed \$10,000. Examples include installation of noise monitoring systems.

Property/Land: The sponsor must incorporate this notice in any agreement associated with land acquisition if the agreement includes construction work (defined above) that exceeds \$10,000. Examples include demolition of structures or installation of boundary fencing.

Use of Provision – The sponsor must incorporate the text of this provision without modification. The sponsor must incorporate the established minority participation goal and the covered area by geographic name within the provision text.

A2.3 CONTRACT CLAUSE

NOTICE OF REQUIREMENT FOR AFFIRMATIVE ACTION to ENSURE EQUAL EMPLOYMENT OPPORTUNITY

1. The Offeror's or Bidder's attention is called to the "Equal Opportunity Clause" and the "Standard Federal Equal Employment Opportunity Construction Contract Specifications" set forth herein.
2. The goals and timetables for minority and female participation, expressed in percentage terms for the contractor's aggregate workforce in each trade on all construction work in the covered area, are as follows:

The following goal for female utilization in each construction craft and trade shall apply to all Contractors holding Federal and federally-assisted construction contracts and subcontracts in excess of \$10,000. The goal is applicable to the Contractor's total on-site construction workforce, regardless of whether or not part of that workforce is performing work on a Federal, federally assisted or nonfederally related construction contract or subcontract.

AREA COVERED (STATEWIDE)

Goals for Women apply nationwide.

GOAL

Goal (percent)

Female Utilization..... 6.9

Until further notice, the following goals for minority utilization in each construction craft and trade shall apply to all Contractors holding Federal and federally-assisted construction contracts and subcontracts in excess of \$10,000 to be performed in the respective geographical areas. The goals are applicable to the Contractor's total on-site construction workforce, regardless of whether or not part of that workforce is performing work on a Federal, federally-assisted or nonfederally related construction contract or subcontract.

<u>Economic Area (percent)</u>	Goal
056 Paducah, KY: Non-SMSA Counties - IL - Hardin, Massac, Pope KY - Ballard, Caldwell, Calloway, Carlisle, Crittenden, Fulton, Graves, Hickman, Livingston, Lyon, McCracken, Marshall	5.2
080 Evansville, IN: Non-SMSA Counties - IL - Edwards, Gallatin, Hamilton, Lawrence, Saline, Wabash, White IN - Dubois, Knox, Perry, Pike, Spencer KY - Hancock, Hopkins, McLean, Mublenberg, Ohio, Union, Webster	3.5
081 Terre Haute, IN: Non-SMSA Counties - IL - Clark, Crawford IN - Parke	2.5
083 Chicago, IL: SMSA Counties: 1600 Chicago, IL - IL - Cook, DuPage, Kane, Lake, McHenry, Will	19.6
3740 Kankakee, IL - IL - Kankakee	9.1
Non-SMSA Counties IL - Bureau, DeKalb, Grundy, Iroquois, Kendall, LaSalle, Livingston, Putnam IN - Jasper, Laporte, Newton, Pulaski, Starke	18.4
084 Champaign - Urbana, IL: SMSA Counties: 1400 Champaign - Urbana - Rantoul, IL - IL - Champaign	7.8
Non-SMSA Counties - IL - Coles, Cumberland, Douglas, Edgar, Ford, Piatt, Vermilion	4.8
085 Springfield - Decatur, IL: SMSA Counties:	

2040 Decatur, IL - IL - Macon	7.6
7880 Springfield, IL - IL - Mendard, Sangamon	4.5
Non-SMSA Counties IL - Cass, Christian, Dewitt, Logan, Morgan, Moultrie, Scott, Shelby	4.0
086 Quincy, IL: Non-SMSA Counties	3.1
IL - Adams, Brown, Pike MO - Lewis, Marion, Pike, Ralls	
087 Peoria, IL: SMSA Counties: 1040 Bloomington - Normal, IL - IL - McLean	2.5
6120 Peoria, IL - IL - Peoria, Tazewell, Woodford	4.4
Non-SMSA Counties - IL - Fulton, Knox, McDonough, Marshall, Mason, Schuyler, Stark, Warren	3.3
088 Rockford, IL: SMSA Counties: 6880 Rockford, IL - IL - Boone, Winnebago	6.3
Non-SMSA Counties - IL - Lee, Ogle, Stephenson	4.6
098 Dubuque, IA: Non-SMSA Counties - IL - JoDaviess IA - Atlamakee, Clayton, Delaware, Jackson, Winnesheik WI - Crawford, Grant, Lafayette	0.5
099 Davenport, Rock Island, Moline, IA - IL: SMSA Counties: 1960 Davenport, Rock Island, Moline, IA - IL - IL - Henry, Rock Island IA - Scott	4.6
Non-SMSA Counties - IL - Carroll, Hancock, Henderson, Mercer, Whiteside IA - Clinton, DesMoines, Henry, Lee, Louisa, Muscatine MO - Clark	3.4
107 St. Louis, MO: SMSA Counties: 7040 St. Louis, MO - IL - IL - Clinton, Madison, Monroe, St. Clair MO - Franklin, Jefferson, St. Charles, St. Louis, St. Louis City	14.7
Non-SMSA Counties - IL - Alexander, Bond, Calhoun, Clay, Effingham, Fayette, Franklin, Greene, Jackson, Jasper, Jefferson, Jersey, Johnson, Macoupin, Marion, Montgomery, Perry, Pulaski, Randolph, Richland, Union, Washington, Wayne, Williamson MO - Bollinger, Butler, Cape Girardeau, Carter, Crawford, Dent, Gasconade, Iron, Lincoln, Madison, Maries, Mississippi, Montgomery, Perry, Phelps, Reynolds, Ripley, St. Francois, St. Genevieve, Scott, Stoddard, Warren, Washington, Wayne	11.4

These goals are applicable to all of the contractor's construction work (whether or not it is Federal or federally-assisted) performed in the covered area. If the contractor performs construction work in a geographical area located outside of the covered area, it shall apply the goals established for such geographical area where the work is actually performed. With regard to this second area, the contractor also is subject to the goals for both its federally involved and non-federally involved construction.

The Contractor's compliance with the Executive Order and the regulations in 41 CFR Part 60-4 shall be based on its implementation of the Equal Opportunity Clause, specific affirmative action obligations required by the specifications set forth in 41 CFR 60-4.3(a), and its efforts to meet the goals.

The hours of minority and female employment and training must be substantially uniform throughout the length of the contract, and in each trade, and the contractor shall make a good faith effort to employ minorities and women evenly on each of its projects. The transfer of minority or female employees or trainees from Contractor to Contractor or from project to project for the sole purpose of meeting the Contractor's goals shall be a violation of the contract, the Executive Order and the regulations in 41 CFR Part 60-4. Compliance with the goals will be measured against the total work hours performed.

3. The Contractor shall provide written notification to the Director of the Office of Federal Contract Compliance Programs (OFCCP) within 10 working days of award of any construction subcontract in excess of \$10,000 at any tier for construction work under the contract resulting from this solicitation. The notification shall list the name, address, and telephone number of the subcontractor; employer identification number of the subcontractor; estimated dollar amount of the subcontract; estimated starting and completion dates of the subcontract; and the geographical area in which the subcontract is to be performed.

4. As used in this notice and in the contract resulting from this solicitation, the "covered area" is Moline, Illinois; Rock Island County.

A3 BREACH OF CONTRACT TERMS

A3.1 SOURCE

2 CFR § 200 Appendix II(A)

A3.2 APPLICABILITY

This provision requires sponsors to incorporate administrative, contractual or legal remedies if contractors violate or breach contract terms. The sponsor must also include appropriate sanctions and penalties.

Contract Types – This provision is required for all contracts that exceed the simplified acquisition threshold as stated in 2 CFR Part 200, Appendix II (A). This threshold is occasionally adjusted for inflation, and is now equal to \$150,000.

Use of Provision – The regulation does not prescribe mandatory language. The following language is acceptable to the FAA and meets the intent of this requirement. If the sponsor uses different language, the sponsor's language must fully satisfy the requirements of part 200. Select either "contractor" or "consultant" as applicable.

A3.3 CONTRACT CLAUSE

BREACH OF CONTRACT TERMS

Any violation or breach of terms of this contract on the part of the contractor or its subcontractors may result in the suspension or termination of this contract or such other action that may be necessary to enforce the rights of the parties of this agreement.

Owner will provide the [*Contractor* / *Consultant*] written notice that describes the nature of the breach and corrective actions the [*Contractor* / *Consultant*] must undertake in order to avoid termination of the contract. Owner reserves the right to withhold payments to Contractor until such time the Contractor corrects the breach or the Owner elects to terminate the contract. The Owner's notice will identify a specific date by which the [*Contractor* / *Consultant*] must correct the breach. Owner may proceed with termination of the contract if the [*Contractor* / *Consultant*] fails to correct the breach by deadline indicated in the Owner's notice.

The duties and obligations imposed by the Contract Documents and the rights and remedies available thereunder are in addition to, and not a limitation of, any duties, obligations, rights and remedies otherwise imposed or available by law.

A4 BUY AMERICAN PREFERENCE

A4.1 SOURCE

Title 49 USC § 50101

A4.2 APPLICABILITY

The sponsor must meet the Buy American preference requirements found in 49 USC § 50101 in all AIP-funded projects. The Buy America requirements flow down from the sponsor to first tier contractors, who are responsible for ensuring that lower tier contractors and subcontractors are in compliance. The Buy American preference also applies to professional service agreements if the agreement includes any manufactured product as a deliverable.

A4.3 CONTRACT CLAUSE

- (a) The Aviation Safety and Capacity Expansion Act of 1990 provides that preference be given to steel and manufactured products produced in the United States when funds are expended pursuant to a grant issued under the Airport Improvement Program (AIP).
- (b) Any and all steel products used in the performance of this contract by the Contractor, subcontractors, producers, and suppliers are required to adhere to the Illinois Steel Products Procurement Act, which requires that all steel items be of 100 percent domestic origin and manufacture. Any products listed under the Federal Aviation Administration's (FAA) nationwide approved list of "Equipment Meeting Buy American Requirements" shall be deemed as meeting the requirements of the Illinois Steel Products Procurement Act.

- (c) The successful bidder will be required to assure that only domestic steel and domestically manufactured products will be used by the Contractor, subcontractors, producers, and suppliers in the performance of this contract. The North American Free Trade Agreement (NAFTA) specifically excluded federal grant programs such as the AIP. Therefore, NAFTA does not change the requirement to comply with the Buy American requirement in the Act. Exceptions to this are for products, other than steel, that:
- (1) the FAA has determined, under the Aviation Safety and Capacity Expansion Act of 1990, are not produced in the United States in sufficient and reasonably available quantities or of a satisfactory quality;
 - (2) the FAA has determined, under the Aviation Safety and Capacity Expansion Act of 1990, that domestic preference would be inconsistent with the public interest;
 - (3) the FAA has determined that inclusion of domestic material will increase the cost of the overall project contract by more than 25 percent; or
 - (4) the FAA has determined, under the Aviation Safety and Capacity Expansion Act of 1990,
 - (i) the cost of components and subcomponents produced in the United States is more than 60 percent of the cost of all components of the facility or equipment, and
 - (ii) final assembly of the facility or equipment has occurred in the United States.

The FAA must grant waivers for any items that are included in these above exceptions. Bidders can review items already approved under the FAA nationwide approved list of "Equipment Meeting Buy American Requirements" on the FAA website, which do not require a specific FAA waiver.

All waivers are the responsibility of the Contractor, must be obtained prior to the Notice to Proceed, and must be submitted to the Illinois Division of Aeronautics for review and approval before being forwarded to the FAA. Any products used on the project that cannot meet the domestic requirement, and for which a waiver prior to the Notice to Proceed was not obtained, will be rejected for use and subject to removal and replacement with no additional compensation, and the contractor deemed non-responsive.

A5 CIVIL RIGHTS - GENERAL

A5.1 SOURCE

49 USC § 47123

A5.2 APPLICABILITY

Note: This provision is in addition to the Civil Rights – Title VI provisions.

Contract Types – The General Civil Rights Provisions found in 49 USC § 47123, derived from the Airport and Airway Improvement Act of 1982, Section 520, apply to all sponsor contracts regardless of funding source.

Use of Provision – There are two versions of this provision. One applies to sponsor contracts and the other applies to sponsor lease agreements and transfer agreements. The sponsor must incorporate the text of the appropriate provision without modification.

A5.3 CONTRACT CLAUSE

A5.3.1 Sponsor Contracts

GENERAL CIVIL RIGHTS PROVISIONS

The contractor agrees to comply with pertinent statutes, Executive Orders and such rules as are promulgated to ensure that no person shall, on the grounds of race, creed, color, national origin, sex, age, or disability be excluded from participating in any activity conducted with or benefiting from Federal assistance.

This provision binds the contractor and subtier contractors from the bid solicitation period through the completion of the contract. This provision is in addition to that required of Title VI of the Civil Rights Act of 1964.

A5.3.2 Sponsor Lease Agreements and Transfer Agreements

GENERAL CIVIL RIGHTS PROVISIONS

The tenant/concessionaire/lessee and its transferee agree to comply with pertinent statutes, Executive Orders and such rules as are promulgated to ensure that no person shall, on the grounds of race, creed, color, national origin, sex, age, or disability be excluded from participating in any activity conducted with or benefiting from Federal assistance.

This provision obligates the tenant/concessionaire/lessee or its transferee for the period during which Federal assistance is extended to the airport through the Airport Improvement Program.

In cases where Federal assistance provides, or is in the form of personal property; real property or interest therein; structures or improvements thereon, this provision obligates the party or any transferee for the longer of the following periods:

(a) The period during which the property is used by the airport sponsor or any transferee for a purpose for which Federal assistance is extended, or for another purpose involving the provision of similar services or benefits; or

(b) The period during which the airport sponsor or any transferee retains ownership or possession of the property.

A6 CIVIL RIGHTS – TITLE VI ASSURANCE

A6.1 SOURCE

49 USC § 47123

FAA Order 1400.11

A6.2 APPLICABILITY

Title VI of the Civil Rights Act of 1964, as amended, (Title VI) prohibits discrimination on the grounds of race, color, or national origin under any program or activity receiving Federal financial assistance. Sponsors must include appropriate clauses from the Standard DOT Title VI Assurances in all contracts and solicitations.

The clauses are as follows:

A6.2.1 Applicability of Title VI Solicitation Notice

a. Contract Clause	b. The Sponsor must include the contract clause in:	c. Clause Text is Included in Paragraph
d. Title VI Solicitation Notice	1) All solicitations for bids, requests for proposals work, or material subject to the nondiscrimination acts and regulations made in connection with Airport Improvement Program grants; and 2) All proposals for negotiated agreements regardless of funding source.	e. A6.3.1
f. Title VI Clauses for Compliance with Nondiscrimination Requirements	g. Every contract or agreement, unless the sponsor has determined and the FAA concurs, that the contract or agreement is not subject to the Nondiscrimination Acts and Authorities	h. A6.3.2
Title VI Required Clause for Property Interests Transferred from the United States	i. As a covenant running with the land, in any deed from the United States effecting or recording a transfer of real property, structures, use, or improvements thereon or interest therein to a sponsor.	j. A6.3.3
k. Title VI Required Clause for Transfer of Real Property Acquired or Improved Under the Activity, Facility or Program	l. As a covenant running with the land, in any future deeds, leases, licenses, permits, or similar instruments entered into by the sponsor with other parties for all transfers of real property acquired or improved under the activity, facility, or program	m. A6.3.4
Clauses for Construction/Use/Access to Real Property Acquired Under the Activity, Facility or Program	n. As a covenant running with the land, in any future deeds, leases, licenses, permits, or similar instruments entered into by the sponsor with other parties for the construction or use of, or access to, space on, over, or under real property acquired or improved under the applicable activity, project, or program	o. A6.3.5
Title VI List Of Pertinent Nondiscrimination Acts And Authorities	p. Insert this list in every contract or agreement, unless the sponsor has determined and the FAA concurs, that the contract or agreement is not subject to the Nondiscrimination Acts and Authorities	q. A6.3.6

A6.3 CONTRACT CLAUSE

A6.3.1 Title VI Solicitation Notice

Title VI Solicitation Notice:

The Metropolitan Airport Authority of Rock Island, in accordance with the provisions of Title VI of the Civil Rights Act of 1964 (78 Stat. 252, 42 U.S.C. §§ 2000d to 2000d-4) and the Regulations, hereby notifies all bidders that it will affirmatively ensure that any contract entered into pursuant to this advertisement, disadvantaged business enterprises will be afforded full and fair opportunity to submit bids in response to this invitation and will not be discriminated against on the grounds of race, color, or national origin in consideration for an award.

A6.3.2 Title VI Clauses for Compliance with Nondiscrimination Requirements

Compliance with Nondiscrimination Requirements

During the performance of this contract, the contractor, for itself, its assignees, and successors in interest (hereinafter referred to as the "contractor") agrees as follows:

Compliance with Regulations: The contractor (hereinafter includes consultants) will comply with the Title VI List of Pertinent Nondiscrimination Acts And Authorities, as they may be amended from time to time, which are herein incorporated by reference and made a part of this contract.

Non-discrimination: The contractor, with regard to the work performed by it during the contract, will not discriminate on the grounds of race, color, or national origin in the selection and retention of subcontractors, including procurements of materials and leases of equipment. The contractor will not participate directly or indirectly in the discrimination prohibited by the Nondiscrimination Acts and Authorities, including employment practices when the contract covers any activity, project, or program set forth in Appendix B of 49 CFR part 21.

Solicitations for Subcontracts, Including Procurements of Materials and Equipment: In all solicitations, either by competitive bidding, or negotiation made by the contractor for work to be performed under a subcontract, including procurements of materials, or leases of equipment, each potential subcontractor or supplier will be notified by the contractor of the contractor's obligations under this contract and the Nondiscrimination Acts And Authorities on the grounds of race, color, or national origin.

Information and Reports: The contractor will provide all information and reports required by the Acts, the Regulations, and directives issued pursuant thereto and will permit access to its books, records, accounts, other sources of information, and its facilities as may be determined by the sponsor or the Federal Aviation Administration to be pertinent to ascertain compliance with such Nondiscrimination Acts And Authorities and instructions. Where any information required of a contractor is in the exclusive possession of another who fails or refuses to furnish the information, the contractor will so certify to the sponsor or the Federal Aviation Administration, as appropriate, and will set forth what efforts it has made to obtain the information.

Sanctions for Noncompliance: In the event of a contractor's noncompliance with the Non-discrimination provisions of this contract, the sponsor will impose such contract sanctions as it or the Federal Aviation Administration may determine to be appropriate, including, but not limited to:

- a. Withholding payments to the contractor under the contract until the contractor complies; and/or
- b. Cancelling, terminating, or suspending a contract, in whole or in part.

Incorporation of Provisions: The contractor will include the provisions of paragraphs one through six in every subcontract, including procurements of materials and leases of equipment, unless exempt by the Acts, the Regulations and directives issued pursuant thereto. The contractor will take action with respect to any subcontract or procurement as the sponsor or the Federal Aviation Administration may direct as a means of enforcing such provisions including sanctions for noncompliance. Provided, that if the contractor becomes involved in, or is threatened with litigation by a subcontractor, or supplier because of such direction, the contractor may request the sponsor to enter into any litigation to protect the interests of the sponsor. In addition, the contractor may request the United States to enter into the litigation to protect the interests of the United States.

A6.3.3 Title VI Clauses for Deeds Transferring United States Property

CLAUSES FOR DEEDS TRANSFERRING UNITED STATES PROPERTY

The following clauses will be included in deeds effecting or recording the transfer of real property, structures, or improvements thereon, or granting interest therein from the United States pursuant to the provisions of the Airport Improvement Program grant assurances.

NOW, THEREFORE, the Federal Aviation Administration as authorized by law and upon the condition that the Metropolitan Airport Authority of Rock Island will accept title to the lands and maintain the project constructed thereon in accordance with Public Law 114-141, for the Airport Improvement Program and the policies and procedures prescribed by the Federal Aviation Administration of the U.S. Department of Transportation in accordance and in compliance with all requirements imposed by Title 49, Code of Federal Regulations, U.S. Department of Transportation, Subtitle A, Office of the Secretary, Part 21, Non-discrimination in Federally-assisted programs of the U.S. Department of Transportation pertaining to and effectuating the provisions of Title VI of the Civil Rights Act of 1964 (78 Stat. 252; 42 U.S.C. § 2000d to 2000d-4), does hereby remise, release, quitclaim and convey unto the Metropolitan Airport Authority of Rock Island all the right, title and interest of the U.S. Department of Transportation/Federal Aviation Administration in and to said lands described in the Exhibit A.

(HABENDUM CLAUSE)

TO HAVE AND TO HOLD said lands and interests therein unto the Metropolitan Airport Authority of Rock Island and its successors forever, subject, however, to the covenants, conditions, restrictions and reservations herein contained as follows, which will remain in effect for the period during which the real property or structures are used for a purpose for which Federal financial assistance is extended or for another purpose involving the provision of similar services or benefits and will be binding on the Metropolitan Airport Authority of Rock Island, its successors and assigns.

The Metropolitan Airport Authority of Rock Island, in consideration of the conveyance of said lands and interests in lands, does hereby covenant and agree as a covenant running with the land for itself, its successors and assigns, that (1) no person will on the grounds of race, color, or national origin, be excluded from participation in, be denied the benefits of, or be otherwise subjected to discrimination with regard to any facility located wholly or in part on, over, or under such lands hereby conveyed [,] [and]* (2) that the Metropolitan Airport Authority of Rock Island will use the lands and interests

in lands and interests in lands so conveyed, in compliance with all requirements imposed by or pursuant to Title 49, Code of Federal Regulations, U.S. Department of Transportation, Subtitle A, Office of the Secretary, Part 21, Non-discrimination in Federally-assisted programs of the U.S. Department of Transportation, Effectuation of Title VI of the Civil Rights Act of 1964, and as said Regulations and Acts may be amended[, and (3) that in the event of breach of any of the above-mentioned non-discrimination conditions, the Department will have a right to enter or re-enter said lands and facilities on said land, and that above described land and facilities will thereon revert to and vest in and become the absolute property of the Federal Aviation Administration and its assigns as such interest existed prior to this instruction].*

(*Reverter clause and related language to be used only when it is determined that such a clause is necessary in order to make clear the purpose of Title VI.)

A6.3.4 Title VI Clauses for Transfer of Real Property Acquired or Improved Under the Activity, Facility, or Program

CLAUSES FOR TRANSFER OF REAL PROPERTY ACQUIRED OR IMPROVED UNDER THE ACTIVITY, FACILITY, OR PROGRAM

The following clauses will be included in deeds, licenses, leases, permits, or similar instruments entered into by the Metropolitan Airport Authority of Rock Island pursuant to the provisions of the Airport Improvement Program grant assurances.

- A. The (grantee, lessee, permittee, etc. as appropriate) for himself/herself, his/her heirs, personal representatives, successors in interest, and assigns, as a part of the consideration hereof, does hereby covenant and agree [in the case of deeds and leases add "as a covenant running with the land"] that:
 - 1. In the event facilities are constructed, maintained, or otherwise operated on the property described in this (deed, license, lease, permit, etc.) for a purpose for which a Federal Aviation Administration activity, facility, or program is extended or for another purpose involving the provision of similar services or benefits, the (grantee, licensee, lessee, permittee, etc.) will maintain and operate such facilities and services in compliance with all requirements imposed by the Nondiscrimination Acts and Regulations listed in the Pertinent List of Nondiscrimination Authorities (as may be amended) such that no person on the grounds of race, color, or national origin, will be excluded from participation in, denied the benefits of, or be otherwise subjected to discrimination in the use of said facilities.
- B. With respect to licenses, leases, permits, etc., in the event of breach of any of the above Nondiscrimination covenants, the Metropolitan Airport Authority of Rock Island will have the right to terminate the (lease, license, permit, etc.) and to enter, re-enter, and repossess said lands and facilities thereon, and hold the same as if the (lease, license, permit, etc.) had never been made or issued.*
- C. With respect to a deed, in the event of breach of any of the above Nondiscrimination covenants, the Metropolitan Airport Authority of Rock Island will have the right to enter or re-enter the lands and facilities thereon, and the above described lands and facilities will there upon revert to and vest in and become the absolute property of the Metropolitan Airport Authority of Rock Island and its assigns.*

(*Reverter clause and related language to be used only when it is determined that such a clause is necessary to make clear the purpose of Title VI.)

A6.3.5 Title VI Clauses for Construction/Use/Access to Real Property Acquired Under the Activity, Facility or Program

CLAUSES FOR CONSTRUCTION/USE/ACCESS TO REAL PROPERTY ACQUIRED UNDER THE ACTIVITY, FACILITY OR PROGRAM

The following clauses will be included in deeds, licenses, permits, or similar instruments/agreements entered into by the Metropolitan Airport Authority of Rock Island pursuant to the provisions of the Airport Improvement Program grant assurances.

- A. The (grantee, licensee, permittee, etc., as appropriate) for himself/herself, his/her heirs, personal representatives, successors in interest, and assigns, as a part of the consideration hereof, does hereby covenant and agree (in the case of deeds and leases add, "as a covenant running with the land") that (1) no person on the ground of race, color, or national origin, will be excluded from participation in, denied the benefits of, or be otherwise subjected to discrimination in the use of said facilities, (2) that in the construction of any improvements on, over, or under such land, and the furnishing of services thereon, no person on the ground of race, color, or national origin, will be excluded from participation in, denied the benefits of, or otherwise be subjected to discrimination, (3) that the (grantee, licensee, lessee, permittee, etc.) will use the premises in compliance with all other requirements imposed by or pursuant to the List of discrimination Acts And Authorities.
- B. With respect to (licenses, leases, permits, etc.), in the event of breach of any of the above nondiscrimination covenants, the Metropolitan Airport Authority of Rock Island will have the right to terminate the (license, permit, etc., as appropriate) and to enter or re-enter and repossess said land and the facilities thereon, and hold the same as if said (license, permit, etc., as appropriate) had never been made or issued.*
- C. With respect to deeds, in the event of breach of any of the above nondiscrimination covenants, the Metropolitan Airport Authority of Rock Island will there upon revert to and vest in and become the absolute property of the Metropolitan Airport Authority of Rock Island and its assigns.*

(*Reverter clause and related language to be used only when it is determined that such a clause is necessary to make clear the purpose of Title VI.)

A6.3.6 Title VI List of Pertinent Nondiscrimination Acts and Authorities

Title VI List of Pertinent Nondiscrimination Acts and Authorities

During the performance of this contract, the contractor, for itself, its assignees, and successors in interest (hereinafter referred to as the "contractor") agrees to comply with the following non-discrimination statutes and authorities; including but not limited to:

Title VI of the Civil Rights Act of 1964 (42 U.S.C. § 2000d *et seq.*, 78 stat. 252), (prohibits discrimination on the basis of race, color, national origin);

49 CFR part 21 (Non-discrimination In Federally-Assisted Programs of The Department of Transportation—Effectuation of Title VI of The Civil Rights Act of 1964);

The Uniform Relocation Assistance and Real Property Acquisition Policies Act of 1970, (42 U.S.C. § 4601), (prohibits unfair treatment of persons displaced or whose property has been acquired because of Federal or Federal-aid programs and projects);

Section 504 of the Rehabilitation Act of 1973, (29 U.S.C. § 794 *et seq.*), as amended, (prohibits discrimination on the basis of disability); and 49 CFR part 27;

The Age Discrimination Act of 1975, as amended, (42 U.S.C. § 6101 *et seq.*), (prohibits discrimination on the basis of age);

Airport and Airway Improvement Act of 1982, (49 USC § 471, Section 47123), as amended, (prohibits discrimination based on race, creed, color, national origin, or sex);

The Civil Rights Restoration Act of 1987, (PL 100-209), (Broadened the scope, coverage and applicability of Title VI of the Civil Rights Act of 1964, The Age Discrimination Act of 1975 and Section 504 of the Rehabilitation Act of 1973, by expanding the definition of the terms “programs or activities” to include all of the programs or activities of the Federal-aid recipients, sub-recipients and contractors, whether such programs or activities are Federally funded or not);

Titles II and III of the Americans with Disabilities Act of 1990, which prohibit discrimination on the basis of disability in the operation of public entities, public and private transportation systems, places of public accommodation, and certain testing entities (42 U.S.C. §§ 12131 – 12189) as implemented by Department of Transportation regulations at 49 CFR parts 37 and 38;

The Federal Aviation Administration’s Non-discrimination statute (49 U.S.C. § 47123) (prohibits discrimination on the basis of race, color, national origin, and sex);

Executive Order 12898, Federal Actions to Address Environmental Justice in Minority Populations and Low-Income Populations, which ensures non-discrimination against minority populations by discouraging programs, policies, and activities with disproportionately high and adverse human health or environmental effects on minority and low-income populations;

Executive Order 13166, Improving Access to Services for Persons with Limited English Proficiency, and resulting agency guidance, national origin discrimination includes discrimination because of limited English proficiency (LEP). To ensure compliance with Title VI, you must take reasonable steps to ensure that LEP persons have meaningful access to your programs (70 Fed. Reg. at 74087 to 74100);

Title IX of the Education Amendments of 1972, as amended, which prohibits you from discriminating because of sex in education programs or activities (20 U.S.C. 1681 *et seq.*).

A7 CLEAN AIR AND WATER POLLUTION CONTROL

A7.1 SOURCE

2 CFR § 200, Appendix II(G)

A7.2 APPLICABILITY

Contract Types – This provision is required for all contracts and lower tier contracts that exceed \$150,000.

Use of Provision – The regulation does not prescribe mandatory language. The following language is acceptable to the FAA and meets the intent of this requirement. If the sponsor uses different language, the sponsor’s language must fully satisfy the requirements of Appendix II to 2 CFR §200.

A7.3 CONTRACT CLAUSE

CLEAN AIR AND WATER POLLUTION CONTROL

Contractor agrees to comply with all applicable standards, orders, and regulations issued pursuant to the Clean Air Act (42 U.S.C. § 740-7671q) and the Federal Water Pollution Control Act as amended (33 U.S.C. § 1251-1387). The Contractor agrees to report any violation to the Owner immediately upon discovery. The Owner assumes responsibility for notifying the Environmental Protection Agency (EPA) and the Federal Aviation Administration.

Contractor must include this requirement in all subcontracts that exceeds \$150,000.

A8 CONTRACT WORKHOURS AND SAFETY STANDARDS ACT REQUIREMENTS

A8.1 SOURCE

2 CFR § 200, Appendix II(E)

A8.2 APPLICABILITY

Contract Workhours and Safety Standards Act Requirements, (CWHSSA) requires contractors and subcontractors on covered contracts to pay laborers and mechanics employed in the performance of the contracts one and one-half times their basic rate of pay for all hours worked over 40 in a workweek. CWHSSA prohibits unsanitary, hazardous, or dangerous working conditions on federally assisted projects. The Wage and Hour Division (WHD) within the U.S. Department of Labor (DOL) enforces the compensation requirements of this Act, while DOL’s Occupational Safety and Health Administration (OSHA) enforces the safety and health requirements

Contract Types –

Construction - This provision applies to all contracts and lower tier contracts that exceed \$100,000, and employ laborers, mechanics, watchmen and guards.

Equipment - This provision applies to any equipment project exceeding \$100,000 that involves installation of equipment onsite (e.g. electrical vault equipment). This provision does not apply to equipment acquisition projects where the manufacture of the equipment takes place offsite at the vendor plant (e.g. ARFF and SRE vehicles)

Professional Services - This provision applies to professional service agreements that exceed \$100,000 and employs laborers, mechanics, watchmen and guards. This includes members of survey crews and exploratory drilling operations.

Property – While most land transactions do not involve employment of laborers, mechanics, watchmen and guards, under certain circumstances, a property acquisition project could require such employment. Examples include the installation of property fencing or testing for environmental contamination

Use of Provision – Sponsors must incorporate this text without modification.

A8.3 CONTRACT CLAUSE

CONTRACT WORKHOURS AND SAFETY STANDARDS ACT REQUIREMENTS

1. Overtime Requirements.

No contractor or subcontractor contracting for any part of the contract work which may require or involve the employment of laborers or mechanics shall require or permit any such laborer or mechanic, including watchmen and guards, in any workweek in which he or she is employed on such work to work in excess of forty hours in such workweek unless such laborer or mechanic receives compensation at a rate not less than one and one-half times the basic rate of pay for all hours worked in excess of forty hours in such workweek.

2. Violation; Liability for Unpaid Wages; Liquidated Damages.

In the event of any violation of the clause set forth in paragraph (1) of this clause, the contractor and any subcontractor responsible therefor shall be liable for the unpaid wages. In addition, such contractor and subcontractor shall be liable to the United States (in the case of work done under contract for the District of Columbia or a territory, to such District or to such territory), for liquidated damages. Such liquidated damages shall be computed with respect to each individual laborer or mechanic, including watchmen and guards, employed in violation of the clause set forth in paragraph (1) of this clause, in the sum of \$10 for each calendar day on which such individual was required or permitted to work in excess of the standard workweek of forty hours without payment of the overtime wages required by the clause set forth in paragraph (1) of this clause.

3. Withholding for Unpaid Wages and Liquidated Damages.

The Federal Aviation Administration (FAA) or the Owner shall upon its own action or upon written request of an authorized representative of the Department of Labor withhold or cause to be withheld, from any moneys payable on account of work performed by the contractor or subcontractor under any such contract or any other Federal contract with the same prime contractor, or any other Federally-assisted contract subject to the Contract Work Hours and Safety Standards Act, which is held by the same prime contractor, such sums as may be determined to be necessary to satisfy any liabilities of such contractor or subcontractor for unpaid wages and liquidated damages as provided in the clause set forth in paragraph 2 of this clause.

4. Subcontractors.

The contractor or subcontractor shall insert in any subcontracts the clauses set forth in paragraphs (1) through (4) and also a clause requiring the subcontractor to include these clauses in any lower tier subcontracts. The prime contractor shall be responsible for compliance by any subcontractor or lower tier subcontractor with the clauses set forth in paragraphs (1) through (4) of this clause.

A9 COPELAND “ANTI-KICKBACK” ACT

A9.1 SOURCE

2 CFR § 200, Appendix II(D)

29 CFR Parts 3 & 5

A9.2 APPLICABILITY and PURPOSE

The Copeland (Anti-Kickback) Act (18 U.S.C. 874 and 40 U.S.C. 3145) makes it unlawful to induce by force, intimidation, threat of dismissal from employment, or by any other manner, any person employed in the construction or repair of public buildings or public works, financed in whole or in part by the United States, to give up any part of the compensation to which that person is entitled under a contract of employment. The Copeland Act also requires each contractor and subcontractor to furnish weekly a statement of compliance with respect to the wages paid each employee during the preceding week.

Contract Types –

Construction – This provision applies to all construction contracts and subcontracts financed under the AIP program that exceeds \$2,000.

Equipment – This provision applies to all equipment installation projects (e.g. electrical vault improvements) financed under the AIP program that exceeds \$ 2, 000. This provision does not apply to equipment acquisitions where the equipment is manufactured at the vendor’s plant (e.g. SRE and ARFF vehicles)

Professional Services - The emergence of different project delivery methods has created situations where Professional Service Agreements (PSA) includes tasks that meet the definition of construction, alteration or repair as defined in 29 CFR Part 5. If such tasks result in work that qualifies as construction, alteration or repair and it exceeds \$2,000, the PSA must incorporate the Copeland Anti-kickback provision.

Property - Ordinarily, land acquisition projects would not involve employment of laborers or mechanics and thus the Copeland Anti-Kickback provision would not apply. However, land projects that involve installation of boundary fencing and demolition of structures would involve laborers and mechanics. The sponsor must include this provision if the land acquisition project involves employment of laborers or mechanics for a contract exceeding \$2,000.

Use of Provision – 29 CFR Part 5 establishes specific language a sponsor must use in construction contracts. The sponsor may not make any modification to the standard language. A/E firms that employ laborers and mechanics on a task that meets the definition of construction, alteration or repair are acting as a contractor. The sponsor may not substitute the term “contractor” for “consultant” in such instances.

A9.3 CONTRACT CLAUSE

COPELAND “ANTI-KICKBACK” ACT

Contractor must comply with the requirements of the Copeland “Anti-Kickback” Act (18 U.S.C. 874 and 40 U.S.C. 3145), as supplemented by Department of Labor regulation 29 CFR part 3. Contractor and subcontractors are prohibited from inducing, by any means, any person employed on the project to give up any part of the compensation to which the employee is entitled. The Contractor and each Subcontractor must submit to the Owner, a weekly statement on the wages paid to each employee performing on covered work during the prior week. Owner must report any violations of the Act to the Federal Aviation Administration.

A10 DAVIS-BACON REQUIREMENTS

A10.1 SOURCE

2 CFR § 200, Appendix II(D)

29 CFR Part 5

A10.2 APPLICABILITY

The Davis-Bacon Act ensures that laborers and mechanics employed under the contract receive pay no less than the locally prevailing wages and fringe benefits as determined by the Department of Labor.

Contract Types –

Construction - Incorporate into all construction contracts and subcontracts that exceed \$2,000 and include funding from the AIP program.

Equipment – This provision applies to all equipment installation projects (e.g. electrical vault improvements) financed under the AIP program that exceeds \$ 2, 000. This provision does not apply to equipment acquisitions where the equipment is manufactured at the vendor’s plant (e.g. SRE and ARFF vehicles)

Professional Services - The emergence of different project delivery methods has created situations where Professional Service Agreements (PSA) includes tasks that meet the definition of construction, alteration or repair as defined in 29 CFR Part 5. If such tasks result in work that qualifies as construction, alteration or repair and it exceeds \$2,000, the PSA must incorporate this clause.

Property - Ordinarily, land acquisition projects would not involve employment of laborers or mechanics and thus the provision would not apply. However, land projects that involve installation of boundary fencing and demolition of structures would involve laborers and mechanics. The sponsor must include this provision if the land acquisition project involves employment of laborers or mechanics for a contract exceeding \$2,000.

Fencing Projects - Fencing projects that exceed \$2,000 must include this provision.

Use of Provision – 29 CFR Part 5 establishes specific language a sponsor must use. The sponsor may not make any modification to the standard language. A/E firms that employ laborers and mechanics on a task that meets the definition of construction, alteration or repair are acting as a contractor. The sponsor may not substitute the term “contractor” for “consultant” in such instances.

A10.3 CONTRACT CLAUSE

DAVIS-BACON REQUIREMENTS

1. Minimum Wages

(i) All laborers and mechanics employed or working upon the site of the work will be paid unconditionally and not less often than once a week, and without subsequent deduction or rebate on any account (except such payroll deductions as are permitted by the Secretary of Labor under the Copeland Act (29 CFR Part 3)), the full amount of wages and bona fide fringe benefits (or cash equivalent thereof) due at time of payment computed

at rates not less than those contained in the wage determination of the Secretary of Labor which is attached hereto and made a part hereof, regardless of any contractual relationship which may be alleged to exist between the contractor and such laborers and mechanics.

Contributions made or costs reasonably anticipated for bona fide fringe benefits under section 1(b)(2) of the Davis-Bacon Act on behalf of laborers or mechanics are considered wages paid to such laborers or mechanics, subject to the provisions of paragraph (1)(iv) of this section; also, regular contributions made or costs incurred for more than a weekly period (but not less often than quarterly) under plans, funds, or programs which cover the particular weekly period, are deemed to be constructively made or incurred during such weekly period. Such laborers and mechanics shall be paid the appropriate wage rate and fringe benefits on the wage determination for the classification of work actually performed, without regard to skill, except as provided in 29 CFR Part 5.5(a)(4). Laborers or mechanics performing work in more than one classification may be compensated at the rate specified for each classification for the time actually worked therein: *Provided*, that the employer's payroll records accurately set forth the time spent in each classification in which work is performed. The wage determination (including any additional classification and wage rates conformed under (1)(ii) of this section) and the Davis-Bacon poster (WH-1321) shall be posted at all times by the contractor and its subcontractors at the site of the work in a prominent and accessible place where it can easily be seen by the workers.

(ii)(A) The contracting officer shall require that any class of laborers or mechanics, including helpers, which is not listed in the wage determination and which is to be employed under the contract shall be classified in conformance with the wage determination. The contracting officer shall approve an additional classification and wage rate and fringe benefits therefore only when the following criteria have been met:

(1) The work to be performed by the classification requested is not performed by a classification in the wage determination; and

(2) The classification is utilized in the area by the construction industry; and

(3) The proposed wage rate, including any bona fide fringe benefits, bears a reasonable relationship to the wage rates contained in the wage determination.

(B) If the contractor and the laborers and mechanics to be employed in the classification (if known), or their representatives, and the contracting officer agree on the classification and wage rate (including the amount designated for fringe benefits where appropriate), a report of the action taken shall be sent by the contracting officer to the Administrator of the Wage and Hour Division, Employment Standards Administration, U.S. Department of Labor, Washington, D.C. 20210. The Administrator, or an authorized representative, will approve, modify, or disapprove every additional classification action within 30 days of receipt and so advise the contracting officer or will notify the contracting officer within the 30-day period that additional time is necessary.

(C) In the event the contractor, the laborers or mechanics to be employed in the classification or their representatives, and the contracting officer do not agree on the proposed classification and wage rate (including the amount designated for fringe benefits where appropriate), the contracting officer shall refer the questions, including the views of all interested parties and the recommendation of the contracting officer, to the Administrator for determination. The Administrator, or an authorized representative, will issue a determination within 30 days of receipt and so advise the contracting officer or will notify the contracting officer within the 30-day period that additional time is necessary.

(D) The wage rate (including fringe benefits where appropriate) determined pursuant to subparagraphs (1)(ii) (B) or (C) of this paragraph, shall be paid to all workers performing work in the classification under this contract from the first day on which work is performed in the classification.

(iii) Whenever the minimum wage rate prescribed in the contract for a class of laborers or mechanics includes a fringe benefit which is not expressed as an hourly rate, the contractor shall either pay the benefit as stated in the wage determination or shall pay another bona fide fringe benefit or an hourly cash equivalent thereof.

(iv) If the contractor does not make payments to a trustee or other third person, the contractor may consider as part of the wages of any laborer or mechanic the amount of any costs reasonably anticipated in providing bona fide fringe benefits under a plan or program, *Provided*, That the Secretary of Labor has found, upon the written request of the contractor, that the applicable standards of the Davis-Bacon Act have been met. The Secretary of Labor may require the contractor to set aside in a separate account assets for the meeting of obligations under the plan or program.

2 Withholding.

The Federal Aviation Administration or the sponsor shall upon its own action or upon written request of an authorized representative of the Department of Labor withhold or cause to be withheld from the contractor under this contract or any other Federal contract with the same prime contractor, or any other Federally-assisted contract subject to Davis-Bacon prevailing wage requirements, which is held by the same prime contractor, so much of the accrued payments or advances as may be considered necessary to pay laborers and mechanics, including apprentices, trainees, and helpers, employed by the contractor or any subcontractor the full amount of wages required by the contract. In the event of failure to pay any laborer or mechanic, including any apprentice, trainee, or helper, employed or working on the site of work, all or part of the wages required by the contract, the Federal Aviation Administration may, after written notice to the contractor, sponsor, applicant, or owner, take such action as may be necessary to cause the suspension of any further payment, advance, or guarantee of funds until such violations have ceased.

3. Payrolls and basic records.

(i) Payrolls and basic records relating thereto shall be maintained by the contractor during the course of the work and preserved for a period of three years thereafter for all laborers and mechanics working at the site of the work. Such records shall contain the name, address, and social security number of each such worker, his or her correct classification, hourly rates of wages paid (including rates of contributions or costs anticipated for bona fide fringe benefits or cash equivalents thereof of the types described in 1(b)(2)(B) of the Davis-Bacon Act), daily and weekly number of hours worked, deductions made and actual wages paid. Whenever the Secretary of Labor has found under 29 CFR 5.5(a)(1)(iv) that the wages of any laborer or mechanic include the amount of any costs reasonably anticipated in providing benefits under a plan or program described in section 1(b)(2)(B) of the Davis-Bacon Act, the contractor shall maintain records which show that the commitment to provide such benefits is enforceable, that the plan or program is financially responsible, and that the plan or program has been communicated in writing to the laborers or mechanics affected, and records

which show the costs anticipated or the actual costs incurred in providing such benefits. Contractors employing apprentices or trainees under approved programs shall maintain written evidence of the registration of apprenticeship programs and certification of trainee programs, the registration of the apprentices and trainees, and the ratios and wage rates prescribed in the applicable programs.

(ii)(A) The contractor shall submit weekly for each week in which any contract work is performed a copy of all payrolls to the Federal Aviation Administration if the agency is a party to the contract, but if the agency is not such a party, the contractor will submit the payrolls to the applicant, sponsor, or owner, as the case may be, for transmission to the Federal Aviation Administration. The payrolls submitted shall set out accurately and completely all of the information required to be maintained under 29 CFR 5.5(a)(3)(i), except that full social security numbers and home addresses shall not be included on weekly transmittals. Instead the payrolls shall only need to include an individually identifying number for each employee (e.g., the last four digits of the employee's social security number). The required weekly payroll information may be submitted in any form desired. Optional Form WH-347 is available for this purpose from the Wage and Hour Division Web site at <http://www.dol.gov/esa/whd/forms/wh347instr.htm> or its successor site. The prime contractor is responsible for the submission of copies of payrolls by all subcontractors. Contractors and subcontractors shall maintain the full social security number and current address of each covered worker, and shall provide them upon request to the Federal Aviation Administration if the agency is a party to the contract, but if the agency is not such a party, the contractor will submit them to the applicant, sponsor, or owner, as the case may be, for transmission to the Federal Aviation Administration, the contractor, or the Wage and Hour Division of the Department of Labor for purposes of an investigation or audit of compliance with prevailing wage requirements. It is not a violation of this section for a prime contractor to require a subcontractor to provide addresses and social security numbers to the prime contractor for its own records, without weekly submission to the sponsoring government agency (or the applicant, sponsor, or owner).

(B) Each payroll submitted shall be accompanied by a "Statement of Compliance," signed by the contractor or subcontractor or his or her agent who pays or supervises the payment of the persons employed under the contract and shall certify the following:

(1) That the payroll for the payroll period contains the information required to be provided under 29 CFR § 5.5(a)(3)(ii), the appropriate information is being maintained under 29 CFR § 5.5 (a)(3)(i) and that such information is correct and complete;

(2) That each laborer and mechanic (including each helper, apprentice and trainee) employed on the contract during the payroll period has been paid the full weekly wages earned, without rebate, either directly or indirectly, and that no deductions have been made either directly or indirectly from the full wages earned, other than permissible deductions as set forth in Regulations 29 CFR Part 3;

(3) That each laborer or mechanic has been paid not less than the applicable wage rates and fringe benefits or cash equivalents for the classification of work performed, as specified in the applicable wage determination incorporated into the contract.

(C) The weekly submission of a properly executed certification set forth on the reverse side of Optional Form WH-347 shall satisfy the requirement for submission of the "Statement of Compliance" required by paragraph (3)(ii)(B) of this section.

(D) The falsification of any of the above certifications may subject the contractor or subcontractor to civil or criminal prosecution under Section 1001 of Title 18 and Section 231 of Title 31 of the United States Code.

(iii) The contractor or subcontractor shall make the records required under paragraph (3)(i) of this section available for inspection, copying or transcription by authorized representatives of the sponsor, the Federal Aviation Administration or the Department of Labor, and shall permit such representatives to interview employees during working hours on the job. If the contractor or subcontractor fails to submit the required records or to make them available, the Federal agency may, after written notice to the contractor, sponsor, applicant or owner, take such action as may be necessary to cause the suspension of any further payment, advance, or guarantee of funds. Furthermore, failure to submit the required records upon request or to make such records available may be grounds for debarment action pursuant to 29 CFR 5.12.

4. Apprentices and Trainees.

(i) Apprentices. Apprentices will be permitted to work at less than the predetermined rate for the work they performed when they are employed pursuant to and individually registered in a bona fide apprenticeship program registered with the U.S. Department of Labor, Employment and Training Administration, Bureau of Apprenticeship and Training, or with a State Apprenticeship Agency recognized by the Bureau, or if a person is employed in his or her first 90 days of probationary employment as an apprentice in such an apprenticeship program, who is not individually registered in the program, but who has been certified by the Bureau of Apprenticeship and Training or a State Apprenticeship Agency (where appropriate) to be eligible for probationary employment as an apprentice. The allowable ratio of apprentices to journeymen on the job site in any craft classification shall not be greater than the ratio permitted to the contractor as to the entire work force under the registered program. Any worker listed on a payroll at an apprentice wage rate, who is not registered or otherwise employed as stated above, shall be paid not less than the applicable wage rate on the wage determination for the classification of work actually performed. In addition, any apprentice performing work on the job site in excess of the ratio permitted under the registered program shall be paid not less than the applicable wage rate on the wage determination for the work actually performed. Where a contractor is performing construction on a project in a locality other than that in which its program is registered, the ratios and wage rates (expressed in percentages of the journeyman's hourly rate) specified in the contractor's or subcontractor's registered program shall be observed. Every apprentice must be paid at not less than the rate specified in the registered program for the apprentice's level of progress, expressed as a percentage of the journeymen hourly rate specified in the applicable wage determination. Apprentices shall be paid fringe benefits in accordance with the provisions of the apprenticeship program. If the apprenticeship program does not specify fringe benefits, apprentices must be paid the full amount of fringe benefits listed on the wage determination for the applicable classification. If the Administrator determines that a different practice prevails for the applicable apprentice classification, fringes shall be paid in accordance with that determination. In the event the Bureau of Apprenticeship and Training, or a State Apprenticeship Agency recognized by the Bureau, withdraws approval of an apprenticeship program, the contractor will no longer be permitted to utilize apprentices at less than the applicable predetermined rate for the work performed until an acceptable program is approved.

(ii) Trainees. Except as provided in 29 CFR 5.16, trainees will not be permitted to work at less than the predetermined rate for the work performed unless they are employed pursuant to and individually registered in a program which has received prior approval, evidenced by formal certification by

the U.S. Department of Labor, Employment and Training Administration. The ratio of trainees to journeymen on the job site shall not be greater than permitted under the plan approved by the Employment and Training Administration. Every trainee must be paid at not less than the rate specified in the approved program for the trainee's level of progress, expressed as a percentage of the journeyman hourly rate specified in the applicable wage determination. Trainees shall be paid fringe benefits in accordance with the provisions of the trainee program. If the trainee program does not mention fringe benefits, trainees shall be paid the full amount of fringe benefits listed on the wage determination unless the Administrator of the Wage and Hour Division determines that there is an apprenticeship program associated with the corresponding journeyman wage rate on the wage determination which provides for less than full fringe benefits for apprentices. Any employee listed on the payroll at a trainee rate that is not registered and participating in a training plan approved by the Employment and Training Administration shall be paid not less than the applicable wage rate on the wage determination for the classification of work actually performed. In addition, any trainee performing work on the job site in excess of the ratio permitted under the registered program shall be paid not less than the applicable wage rate on the wage determination for the work actually performed. In the event the Employment and Training Administration withdraws approval of a training program, the contractor will no longer be permitted to utilize trainees at less than the applicable predetermined rate for the work performed until an acceptable program is approved.

(iii) Equal Employment Opportunity. The utilization of apprentices, trainees and journeymen under this part shall be in conformity with the equal employment opportunity requirements of Executive Order 11246, as amended, and 29 CFR Part 30.

5. Compliance with Copeland Act Requirements.

The contractor shall comply with the requirements of 29 CFR Part 3, which are incorporated by reference in this contract.

6. Subcontracts.

The contractor or subcontractor shall insert in any subcontracts the clauses contained in 29 CFR Part 5.5(a)(1) through (10) and such other clauses as the Federal Aviation Administration may by appropriate instructions require, and also a clause requiring the subcontractors to include these clauses in any lower tier subcontracts. The prime contractor shall be responsible for the compliance by any subcontractor or lower tier subcontractor with all the contract clauses in 29 CFR Part 5.5.

7. Contract Termination: Debarment.

A breach of the contract clauses in paragraph 1 through 10 of this section may be grounds for termination of the contract, and for debarment as a contractor and a subcontractor as provided in 29 CFR 5.12.

8. Compliance With Davis-Bacon and Related Act Requirements.

All rulings and interpretations of the Davis-Bacon and Related Acts contained in 29 CFR Parts 1, 3, and 5 are herein incorporated by reference in this contract.

9. Disputes Concerning Labor Standards.

Disputes arising out of the labor standards provisions of this contract shall not be subject to the general disputes clause of this contract. Such disputes shall be resolved in accordance with the procedures of the Department of Labor set forth in 29 CFR Parts 5, 6 and 7. Disputes within the meaning of this clause include disputes between the contractor (or any of its subcontractors) and the contracting agency, the U.S. Department of Labor, or the employees or their representatives.

10. Certification of Eligibility.

(i) By entering into this contract, the contractor certifies that neither it (nor he or she) nor any person or firm who has an interest in the contractor's firm is a person or firm ineligible to be awarded Government contracts by virtue of section 3(a) of the Davis-Bacon Act or 29 CFR 5.12(a)(1).

(ii) No part of this contract shall be subcontracted to any person or firm ineligible for award of a Government contract by virtue of section 3(a) of the Davis-Bacon Act or 29 CFR 5.12(a)(1).

(iii) The penalty for making false statements is prescribed in the U.S. Criminal Code, 18 U.S.C. 1001.

A11 DEBARMENT AND SUSPENSION

A11.1 SOURCE

2 CFR part 180 (Subpart C)

2 CFR part 1200

DOT Order 4200.5

A11.2 APPLICABILITY

The sponsor must verify that the firm or individual that it is entering into a contract with are not presently suspended, excluded or debarred by any Federal department or agency from participating in federally-assisted projects. The sponsor accomplishes this by: (1) checking the System for Award Management (SAM.gov) to verify that the firm or individual is not listed in SAM.gov as being suspended, debarred or excluded, (2) collecting a certification from the firm or individual that they are not suspended, debarred or excluded, and (3) incorporating a clause in the contract that requires lower tier contracts to verify that no suspended, debarred or excluded firm or individual are included in the project.

Contract Types – This requirement applies to *covered transactions*, which are defined in 2 CFR part 180. AIP funded contracts are non-procurement transactions, as defined by §180.970. Covered transactions include any AIP-funded contract, regardless of tier, that is awarded by a contractor,

subcontractor, supplier, consultant, or its agent or representative in any transaction, if the amount of the contract is expected to equal or exceed \$25,000. This includes contracts associated with land acquisition projects.

Use of Provision – The regulation does not prescribe mandatory language, the following language is acceptable to the FAA and meets the intent of this requirement. If the sponsor uses different language, the sponsor's language must fully satisfy the requirements of 2 CFR part 180. For professional service agreements, sponsor may substitute bidder/offeror with consultant.

A 11.3 CONTRACT CLAUSE

A 11.3.1 Bidder or Offeror Certification

CERTIFICATION OF OFFERER/BIDDER REGARDING DEBARMENT

By submitting a bid/proposal under this solicitation, the bidder or offeror certifies that neither it nor its principals are presently debarred or suspended by any Federal department or agency from participation in this transaction.

A 11.3.2 Lower Tier Contract Certification

CERTIFICATION OF LOWER TIER CONTRACTORS REGARDING DEBARMENT

The successful bidder, by administering each lower tier subcontract that exceeds \$25,000 as a "covered transaction", must verify each lower tier participant of a "covered transaction" under the project is not presently debarred or otherwise disqualified from participation in this federally assisted project. The successful bidder will accomplish this by:

1. Checking the System for Award Management at website: <http://www.sam.gov>
2. Collecting a certification statement similar to the Certificate Regarding Debarment and Suspension (Bidder or Offeror), above.
3. Inserting a clause or condition in the covered transaction with the lower tier contract

If the FAA later determines that a lower tier participant failed to disclose to a higher tier participant that it was excluded or disqualified at the time it entered the covered transaction, the FAA may pursue any available remedies, including suspension and debarment of the non-compliant participant.

A 12 DISADVANTAGED BUSINESS ENTERPRISE

A 12.1 SOURCE

49 CFR part 26

A 12.2 APPLICABILITY and PURPOSE

A sponsor that anticipates awarding \$250,000 or more in AIP funded prime contracts in a federal fiscal year must have an approved Disadvantaged Business Enterprise (DBE) program on file with the FAA Office of Civil Rights (§26.21). The approved DBE program will identify a 3-year overall program goal that the sponsor bases on the availability of ready, willing and able DBEs relative to all businesses ready, willing and able to participate on the project (§26.45).

Contract Types – Sponsors with a DBE program on file with the FAA must include the three following provisions, if applicable:

Clause in all solicitations for proposals for which a contract goal has been established.

Clause in each prime contract

Clause in solicitations that are obtaining DBE participation through race/gender neutral means.

Use of Provision –

1. Solicitations with a DBE Project Goal - 49 CFR §26.53 requires a sponsor's solicitation to address what a contractor must submit on proposed DBE participation. This language is not required for projects where DBE participation is by race-gender neutral means.

The regulation does not prescribe mandatory language, the following language is acceptable to the FAA and meets the intent of this requirement. If the sponsor uses different language, the sponsor's revised language must fully these requirements.

The sponsor may require the contractor's submittal on proposed DBE participation either with the bid or within a specified timeframe after bidding.

2. Contracts Covered by DBE Program - Sponsors must incorporate this language if they have a DBE program on file with the FAA. This includes projects where DBE participation is obtained through race-gender neutral means (i.e. no project goal). Sections §26.13 and §26.29 establish mandatory language for contractor assurance and prompt payment. The sponsor must not modify the language.
3. The regulation does not prescribe mandatory language. The following language is acceptable to the FAA and meets the intent of this requirement. If the sponsor uses different language, the sponsor's revised language must fully these requirements for a sponsor that is not applying a project specific contract goal but is covered by a DBE program on file with the FAA.
4. Sponsors that do not have a DBE program on file with the FAA are not required to include DBE provisions and clauses.

A12.3 CONTRACT PROVISIONS

A12.3.1 Solicitation Language (Project Goal)

The Owner's award of this contract is conditioned upon Bidder or Offeror satisfying the good faith effort requirements of 49 CFR §26.53.

As a condition of bid responsiveness, the Bidder or Offeror must submit the following information with their proposal on the forms provided herein:

- (1) The names and addresses of Disadvantaged Business Enterprise (DBE) firms that will participate in the contract;
- (2) A description of the work that each DBE firm will perform;
- (3) The dollar amount of the participation of each DBE firm listed under (1)
- (4) Written statement from Bidder or Offeror that attests their commitment to use the DBE firm(s) listed under (1) to meet the Owner's project goal;
- (5) If Bidder or Offeror cannot meet the advertised project DBE goal; evidence of good faith efforts undertaken by the Bidder or Offeror as described in appendix A to 49 CFR Part 26.

The successful Bidder or Offeror must provide written confirmation of participation from each of the DBE firms the Bidder or Offeror lists in their commitment. This Bidder or Offeror must submit the DBE's written confirmation of participation ["within 5 days of receiving the Owners notice of award" or "with the proposal documents as a condition of bid responsiveness"]

A12.3.2 Contract Clause

DISADVANTAGED BUSINESS ENTERPRISES

Contract Assurance (§ 26.13) - The contractor or subcontractor shall not discriminate on the basis of race, color, national origin, or sex in the performance of this contract. The contractor shall carry out applicable requirements of 49 CFR Part 26 in the award and administration of DOT assisted contracts. Failure by the contractor to carry out these requirements is a material breach of this contract, which may result in the termination of this contract or such other remedy, as the recipient deems appropriate.

Prompt Payment (§26.29) - The prime contractor agrees to pay each subcontractor under this prime contract for satisfactory performance of its contract no later than {specify number} days from the receipt of each payment the prime contractor receives from {Name of recipient}. The prime contractor agrees further to return retainage payments to each subcontractor within {specify the same number as above} days after the subcontractor's work is satisfactorily completed. Any delay or postponement of payment from the above referenced time frame may occur only for good cause following written approval of the {Name of Recipient}. This clause applies to both DBE and non-DBE subcontractors.

A12.3.3 RACE/GENDER NEUTRAL LANGUAGE

The requirements of 49 CFR part 26 apply to this contract. It is the policy of the [Insert Name of Owner] to practice nondiscrimination based on race, color, sex or national origin in the award or performance of this contract. The Owner encourages participation by all firms qualifying under this solicitation regardless of business size or ownership.

A13 DISTRACTED DRIVING

A13.1 SOURCE

Executive Order 13513

DOT Order 3902.10

A13.2 APPLICABILITY

The FAA encourages recipients of Federal grant funds to adopt and enforce safety policies that decrease crashes by distracted drivers, including policies to ban text messaging while driving when performing work related to a grant or sub-grant.

Contract Types – Sponsors must insert this provision in all AIP funded contracts that exceed the micro-purchase threshold of 2 CFR §200.67 (currently set at \$3,500).

Use of Provision – The regulation does not prescribe mandatory language, the following language is acceptable to the FAA and meets the intent of this requirement. If the sponsor uses different language, the sponsor's revised language must fully these requirements. .

A13.3 CONTRACT CLAUSE

TEXTING WHEN DRIVING

In accordance with Executive Order 13513, "Federal Leadership on Reducing Text Messaging While Driving" (10/1/2009) and DOT Order 3902.10 "Text Messaging While Driving" (12/30/2009), the FAA encourages recipients of Federal grant funds to adopt and enforce safety policies that decrease crashes by distracted drivers, including policies to ban text messaging while driving when performing work related to a grant or sub-grant.

In support of this initiative, the Owner encourages the Contractor to promote policies and initiatives for its employees and other work personnel that decrease crashes by distracted drivers, including policies that ban text messaging while driving motor vehicles while performing work activities associated with the project. The Contractor must include the substance of this clause in all sub-tier contracts exceeding \$3,500 and involve driving a motor vehicle in performance of work activities associated with the project.

A14 ENERGY CONSERVATION REQUIREMENTS

A14.1 SOURCE

2 CFR § 200, Appendix II(H)

A14.2 APPLICABILITY

The Energy Conservation Requirements found in 2 CFR § 200 Appendix II(H) requires this provision on energy efficiency.

Contract Types – The sponsor must include this provision in all AIP funded contracts and lower-tier contracts.

Use of Provision – The regulation does not prescribe mandatory language, the following language is acceptable to the FAA and meets the intent of this requirement. If the sponsor uses different language, the sponsor's revised language must fully these requirements. Sponsor may substitute "contractor and subcontractor" with "consultant and sub-consultant" for professional service agreements.

A14.3 CONTRACT CLAUSE

ENERGY CONSERVATION REQUIREMENTS

Contractor and Subcontractor agree to comply with mandatory standards and policies relating to energy efficiency as contained in the state energy conservation plan issued in compliance with the Energy Policy and Conservation Act (42 U.S.C. 6201 *et seq.*).

A15 EQUAL EMPLOYMENT OPPORTUNITY (E.E.O.)

A15.1 SOURCE

2 CFR 200, Appendix II(C)

41 CFR § 60-1.4

41 CFR § 60-4.3

Executive Order 11246

A15.2 APPLICABILITY

The purpose of this provision is to provide equal opportunity for all persons, without regard to race, color, religion, sex, or national origin who are employed or seeking employment with contractors performing under a federally assisted construction contract. There are two provisions – a construction clause and a specification clause.

The equal opportunity contract clause must be included in any contract or subcontract when the amount exceeds \$10,000. Once the equal opportunity clause is determined to be applicable, the contract or subcontract must include the clause for the remainder of the year, regardless of the amount or the contract.

Contract Types –

Construction – The sponsor must incorporate contract and specification language in all construction contracts and subcontracts as required above.

Equipment - The sponsor must incorporate contract and specification language into all equipment contracts as required above that involves installation of equipment onsite (e.g. electrical vault equipment). This provision does not apply to equipment acquisition projects where the manufacture of the equipment takes place offsite at the vendor plant (e.g. ARFF and SRE vehicles)

Professional Services - The sponsor must include contract and specification language into all professional service agreements as required above. *Property* – The sponsor must include contract and specification language into all land acquisition projects that include work that qualifies as construction work as defined by 41 CFR part 60 as required above. An example is installation of boundary fencing.

Use of Provision – 41 CFR § 60-1.4 provides the mandatory contract language. 41 CFR § 60-4.3 provides the mandatory specification language. The sponsor must incorporate these clauses without modification.

A15.3 MANDATORY CONTRACT CLAUSE

A15.3.1 E.E.O. Contract Clause

EQUAL OPPORTUNITY CLAUSE

During the performance of this contract, the contractor agrees as follows:

(1) The contractor will not discriminate against any employee or applicant for employment because of race, color, religion, sex, or national origin. The contractor will take affirmative action to ensure that applicants are employed, and that employees are treated during employment without regard to their race, color, religion, sex, sexual orientation, gender identify or national origin. Such action shall include, but not be limited to the following: employment, upgrading, demotion, or transfer; recruitment or recruitment advertising; layoff or termination; rates of pay or other forms of

compensation; and selection for training, including apprenticeship. The contractor agrees to post in conspicuous places, available to employees and applicants for employment, notices to be provided setting forth the provisions of this nondiscrimination clause.

(2) The contractor will, in all solicitations or advertisements for employees placed by or on behalf of the contractor, state that all qualified applicants will receive considerations for employment without regard to race, color, religion, sex, or national origin.

(3) The contractor will send to each labor union or representative of workers with which he has a collective bargaining agreement or other contract or understanding, a notice to be provided advising the said labor union or workers' representatives of the contractor's commitments under this section, and shall post copies of the notice in conspicuous places available to employees and applicants for employment.

(4) The contractor will comply with all provisions of Executive Order 11246 of September 24, 1965, and of the rules, regulations, and relevant orders of the Secretary of Labor.

(5) The contractor will furnish all information and reports required by Executive Order 11246 of September 24, 1965, and by rules, regulations, and orders of the Secretary of Labor, or pursuant thereto, and will permit access to his books, records, and accounts by the administering agency and the Secretary of Labor for purposes of investigation to ascertain compliance with such rules, regulations, and orders.

(6) In the event of the contractor's noncompliance with the nondiscrimination clauses of this contract or with any of the said rules, regulations, or orders, this contract may be canceled, terminated, or suspended in whole or in part and the contractor may be declared ineligible for further Government contracts or federally assisted construction contracts in accordance with procedures authorized in Executive Order 11246 of September 24, 1965, and such other sanctions may be imposed and remedies invoked as provided in Executive Order 11246 of September 24, 1965, or by rule, regulation, or order of the Secretary of Labor, or as otherwise provided by law.

(7) The contractor will include the portion of the sentence immediately preceding paragraph (1) and the provisions of paragraphs (1) through (7) in every subcontract or purchase order unless exempted by rules, regulations, or orders of the Secretary of Labor issued pursuant to section 204 of Executive Order 11246 of September 24, 1965, so that such provisions will be binding upon each subcontractor or vendor. The contractor will take such action with respect to any subcontract or purchase order as the administering agency may direct as a means of enforcing such provisions, including sanctions for noncompliance: *Provided, however,* That in the event a contractor becomes involved in, or is threatened with, litigation with a subcontractor or vendor as a result of such direction by the administering agency the contractor may request the United States to enter into such litigation to protect the interests of the United States.

A15.3.2 EEO Specification

STANDARD FEDERAL EQUAL EMPLOYMENT OPPORTUNITY CONSTRUCTION CONTRACT SPECIFICATIONS

1. As used in these specifications:

- a. "Covered area" means the geographical area described in the solicitation from which this contract resulted;
- b. "Director" means Director, Office of Federal Contract Compliance Programs (OFCCP), U.S. Department of Labor, or any person to whom the Director delegates authority;
- c. "Employer identification number" means the Federal social security number used on the Employer's Quarterly Federal Tax Return, U.S. Treasury Department Form 941;
- d. "Minority" includes:
 - (1) Black (all) persons having origins in any of the Black African racial groups not of Hispanic origin);
 - (2) Hispanic (all persons of Mexican, Puerto Rican, Cuban, Central or South American, or other Spanish culture or origin regardless of race);
 - (3) Asian and Pacific Islander (all persons having origins in any of the original peoples of the Far East, Southeast Asia, the Indian Subcontinent, or the Pacific Islands); and
 - (4) American Indian or Alaskan native (all persons having origins in any of the original peoples of North America and maintaining identifiable tribal affiliations through membership and participation or community identification).

2. Whenever the contractor, or any subcontractor at any tier, subcontracts a portion of the work involving any construction trade, it shall physically include in each subcontract in excess of \$10,000 the provisions of these specifications and the Notice which contains the applicable goals for minority and female participation and which is set forth in the solicitations from which this contract resulted.

3. If the contractor is participating (pursuant to 41 CFR 60-4.5) in a Hometown Plan approved by the U.S. Department of Labor in the covered area either individually or through an association, its affirmative action obligations on all work in the Plan area (including goals and timetables) shall be in accordance with that Plan for those trades which have unions participating in the Plan. Contractors shall be able to demonstrate their participation in and compliance with the provisions of any such Hometown Plan. Each contractor or subcontractor participating in an approved plan is individually required to comply with its obligations under the EEO clause and to make a good faith effort to achieve each goal under the Plan in each trade in which it has employees. The overall good faith performance by other contractors or subcontractors toward a goal in an approved Plan does not excuse any covered contractor's or subcontractor's failure to take good faith efforts to achieve the Plan goals and timetables.

4. The contractor shall implement the specific affirmative action standards provided in paragraphs 7a through 7p of these specifications. The goals set forth in the solicitation from which this contract resulted are expressed as percentages of the total hours of employment and training of minority and female utilization the contractor should reasonably be able to achieve in each construction trade in which it has employees in the covered area.

Covered construction contractors performing construction work in a geographical area where they do not have a Federal or federally assisted construction contract shall apply the minority and female goals established for the geographical area where the work is being performed. Goals are published periodically in the Federal Register in notice form, and such notices may be obtained from any Office of Federal Contract Compliance Programs office or from Federal procurement contracting officers. The contractor is expected to make substantially uniform progress in meeting its goals in each craft during the period specified.

5. Neither the provisions of any collective bargaining agreement nor the failure by a union with whom the contractor has a collective bargaining agreement to refer either minorities or women shall excuse the contractor's obligations under these specifications, Executive Order 11246 or the regulations promulgated pursuant thereto.

6. In order for the non-working training hours of apprentices and trainees to be counted in meeting the goals, such apprentices and trainees shall be employed by the contractor during the training period and the contractor shall have made a commitment to employ the apprentices and trainees at the completion of their training, subject to the availability of employment opportunities. Trainees shall be trained pursuant to training programs approved by the U.S. Department of Labor.

7. The contractor shall take specific affirmative actions to ensure equal employment opportunity. The evaluation of the contractor's compliance with these specifications shall be based upon its effort to achieve maximum results from its actions. The contractor shall document these efforts fully and shall implement affirmative action steps at least as extensive as the following:

- a. Ensure and maintain a working environment free of harassment, intimidation, and coercion at all sites, and in all facilities at which the contractor's employees are assigned to work. The contractor, where possible, will assign two or more women to each construction project. The contractor shall specifically ensure that all foremen, superintendents, and other onsite supervisory personnel are aware of and carry out the contractor's obligation to maintain such a working environment, with specific attention to minority or female individuals working at such sites or in such facilities.
- b. Establish and maintain a current list of minority and female recruitment sources, provide written notification to minority and female recruitment sources and to community organizations when the contractor or its unions have employment opportunities available, and maintain a record of the organizations' responses.
- c. Maintain a current file of the names, addresses, and telephone numbers of each minority and female off-the-street applicant and minority or female referral from a union, a recruitment source, or community organization and of what action was taken with respect to each such individual. If such individual was sent to the union hiring hall for referral and was not referred back to the contractor by the union or, if referred, not employed by the contractor, this shall be documented in the file with the reason therefore along with whatever additional actions the contractor may have taken.
- d. Provide immediate written notification to the Director when the union or unions with which the contractor has a collective bargaining agreement has not referred to the contractor a minority person or female sent by the contractor, or when the contractor has other information that the union referral process has impeded the contractor's efforts to meet its obligations.
- e. Develop on-the-job training opportunities and/or participate in training programs for the area which expressly include minorities and women, including upgrading programs and apprenticeship and trainee programs relevant to the contractor's employment needs, especially those programs funded or approved by the Department of Labor. The contractor shall provide notice of these programs to the sources compiled under 7b above.
- f. Disseminate the contractor's EEO policy by providing notice of the policy to unions and training programs and requesting their cooperation in assisting the contractor in meeting its EEO obligations; by including it in any policy manual and collective bargaining agreement; by publicizing it in the company newspaper, annual report, etc.; by specific review of the policy with all management personnel and with all minority and female employees at least once a year; and by posting the company EEO policy on bulletin boards accessible to all employees at each location where construction work is performed.
- g. Review, at least annually, the company's EEO policy and affirmative action obligations under these specifications with all employees having any responsibility for hiring, assignment, layoff, termination, or other employment decisions including specific review of these items with onsite supervisory personnel such as superintendents, general foremen, etc., prior to the initiation of construction work at any job site. A written record shall be made and maintained identifying the time and place of these meetings, persons attending, subject matter discussed, and disposition of the subject matter.
- h. Disseminate the contractor's EEO policy externally by including it in any advertising in the news media, specifically including minority and female news media, and providing written notification to and discussing the contractor's EEO policy with other contractors and subcontractors with whom the contractor does or anticipates doing business.
- i. Direct its recruitment efforts, both oral and written, to minority, female, and community organizations, to schools with minority and female students; and to minority and female recruitment and training organizations serving the contractor's recruitment area and employment needs. Not later than one month prior to the date for the acceptance of applications for apprenticeship or other training by any recruitment source, the contractor shall send written notification to organizations, such as the above, describing the openings, screening procedures, and tests to be used in the selection process.
- j. Encourage present minority and female employees to recruit other minority persons and women and, where reasonable, provide after school, summer, and vacation employment to minority and female youth both on the site and in other areas of a contractor's workforce.
- k. Validate all tests and other selection requirements where there is an obligation to do so under 41 CFR Part 60-3.

- l. Conduct, at least annually, an inventory and evaluation at least of all minority and female personnel, for promotional opportunities and encourage these employees to seek or to prepare for, through appropriate training, etc., such opportunities.
- m. Ensure that seniority practices, job classifications, work assignments, and other personnel practices do not have a discriminatory effect by continually monitoring all personnel and employment related activities to ensure that the EEO policy and the contractor's obligations under these specifications are being carried out.
- n. Ensure that all facilities and company activities are non-segregated except that separate or single user toilet and necessary changing facilities shall be provided to assure privacy between the sexes.
- o. Document and maintain a record of all solicitations of offers for subcontracts from minority and female construction contractors and suppliers, including circulation of solicitations to minority and female contractor associations and other business associations.
- p. Conduct a review, at least annually, of all supervisor's adherence to and performance under the contractor's EEO policies and affirmative action obligations.

8. Contractors are encouraged to participate in voluntary associations, which assist in fulfilling one or more of their affirmative action obligations (7a through 7p). The efforts of a contractor association, joint contractor union, contractor community, or other similar groups of which the contractor is a member and participant, may be asserted as fulfilling any one or more of its obligations under 7a through 7p of these specifications provided that the contractor actively participates in the group, makes every effort to assure that the group has a positive impact on the employment of minorities and women in the industry, ensures that the concrete benefits of the program are reflected in the contractor's minority and female workforce participation, makes a good faith effort to meet its individual goals and timetables, and can provide access to documentation which demonstrates the effectiveness of actions taken on behalf of the contractor. The obligation to comply, however, is the contractor's and failure of such a group to fulfill an obligation shall not be a defense for the contractor's noncompliance.

9. A single goal for minorities and a separate single goal for women have been established. The contractor, however, is required to provide equal employment opportunity and to take affirmative action for all minority groups, both male and female, and all women, both minority and non-minority. Consequently, if the particular group is employed in a substantially disparate manner (for example, even though the contractor has achieved its goals for women generally,) the contractor may be in violation of the Executive Order if a specific minority group of women is underutilized.

10. The contractor shall not use the goals and timetables or affirmative action standards to discriminate against any person because of race, color, religion, sex, or national origin.

11. The contractor shall not enter into any subcontract with any person or firm debarred from Government contracts pursuant to Executive Order 11246.

12. The contractor shall carry out such sanctions and penalties for violation of these specifications and of the Equal Opportunity Clause, including suspension, termination, and cancellation of existing subcontracts as may be imposed or ordered pursuant to Executive Order 11246, as amended, and its implementing regulations, by the Office of Federal Contract Compliance Programs. Any contractor who fails to carry out such sanctions and penalties shall be in violation of these specifications and Executive Order 11246, as amended.

13. The contractor, in fulfilling its obligations under these specifications, shall implement specific affirmative action steps, at least as extensive as those standards prescribed in paragraph 7 of these specifications, so as to achieve maximum results from its efforts to ensure equal employment opportunity. If the contractor fails to comply with the requirements of the Executive Order, the implementing regulations, or these specifications, the Director shall proceed in accordance with 41 CFR 60-4.8.

14. The contractor shall designate a responsible official to monitor all employment related activity to ensure that the company EEO policy is being carried out, to submit reports relating to the provisions hereof as may be required by the Government, and to keep records. Records shall at least include for each employee, the name, address, telephone number, construction trade, union affiliation if any, employee identification number when assigned, social security number, race, sex, status (e.g., mechanic, apprentice, trainee, helper, or laborer), dates of changes in status, hours worked per week in the indicated trade, rate of pay, and locations at which the work was performed. Records shall be maintained in an easily understandable and retrievable form; however, to the degree that existing records satisfy this requirement, contractors shall not be required to maintain separate records.

15. Nothing herein provided shall be construed as a limitation upon the application of other laws which establish different standards of compliance or upon the application of requirements for the hiring of local or other area residents (e.g., those under the Public Works Employment Act of 1977 and the Community Development Block Grant Program).

A16 FEDERAL FAIR LABOR STANDARDS ACT (FEDERAL MINIMUM WAGE)

A16.1 SOURCE

29 U.S.C. § 201, et seq

A16.2 APPLICABILITY

The United States Department of Labor (DOL) Wage and Hour Division administers the Fair Labor Standards Act (FLSA). This act prescribes federal standards for basic minimum wage, overtime pay, record keeping and child labor standards.

Contract Types – Per the Department of Labor, all employees of certain enterprises having workers engaged in interstate commerce, producing goods for interstate commerce, or handling, selling, or otherwise working on goods or materials that have been moved in or produced for such commerce by any person, are covered by the FLSA.

All consultants, sub-consultants, contractors and subcontractors employed under this federally assisted project must comply with the FLSA.

Professional Services – 29 CFR § 213 exempts employees in a bona fide executive, administrative or professional capacity. Because professional firms employ individuals that are not covered by this exemption, the sponsor's agreement with a professional services firm must include the FLSA provision.

Use of Provision – The regulation does not prescribe mandatory language, the following language is acceptable to the FAA and meets the intent of this requirement. If the sponsor uses different language, the sponsor's language must fully satisfy the requirements of 29 U.S.C. § 201. The sponsor must select *contractor* or *consultant*, as appropriate for the contract.

A16.3 CONTRACT CLAUSE

All contracts and subcontracts that result from this solicitation incorporate by reference the provisions of 29 CFR part 201, the Federal Fair Labor Standards Act (FLSA), with the same force and effect as if given in full text. The FLSA sets minimum wage, overtime pay, recordkeeping, and child labor standards for full and part time workers.

The [*contractor* / *consultant*] has full responsibility to monitor compliance to the referenced statute or regulation. The [*contractor* / *consultant*] must address any claims or disputes that arise from this requirement directly with the U.S. Department of Labor – Wage and Hour Division

A17 LOBBYING AND INFLUENCING FEDERAL EMPLOYEES

A17.1 SOURCE

31 U.S.C. § 1352 – Byrd Anti-Lobbying Amendment

2 CFR part 200, Appendix II(J)

49 CFR part 20, Appendix A

A17.2 APPLICABILITY

Consultants and contractors that apply or bid for an award of \$100,000 or more must certify that it will not and has not used Federal appropriated funds to pay any person or organization for influencing or attempting to influence an officer or employee of any agency, a member of Congress, officer or employee of Congress, or an employee of a member of Congress in connection with obtaining any Federal contract, grant or another award covered by 31 U.S.C. 1352. Each tier must also disclose any lobbying with non-Federal funds that takes place in connection with obtaining any Federal award.

Contract Types – The sponsor must incorporate this provision into all contracts exceeding \$100,000.

Use of Provision – Appendix A to 49 CFR Part 20 prescribes language the sponsor must use. The sponsor must incorporate this provision without modification.

A17.3 CONTRACT CLAUSE

CERTIFICATION REGARDING LOBBYING

The bidder or offeror certifies by signing and submitting this bid or proposal, to the best of his or her knowledge and belief, that:

- (1) No Federal appropriated funds have been paid or will be paid, by or on behalf of the Bidder or Offeror, to any person for influencing or attempting to influence an officer or employee of an agency, a Member of Congress, an officer or employee of Congress, or an employee of a Member of Congress in connection with the awarding of any Federal contract, the making of any Federal grant, the making of any Federal loan, the entering into of any cooperative agreement, and the extension, continuation, renewal, amendment, or modification of any Federal contract, grant, loan, or cooperative agreement.
- (2) If any funds other than Federal appropriated funds have been paid or will be paid to any person for influencing or attempting to influence an officer or employee of any agency, a Member of Congress, an officer or employee of Congress, or an employee of a Member of Congress in connection with this Federal contract, grant, loan, or cooperative agreement, the undersigned shall complete and submit Standard Form-LLL, "Disclosure Form to Report Lobbying," in accordance with its instructions.
- (3) The undersigned shall require that the language of this certification be included in the award documents for all sub-awards at all tiers (including subcontracts, sub-grants, and contracts under grants, loans, and cooperative agreements) and that all sub-recipients shall certify and disclose accordingly.

This certification is a material representation of fact upon which reliance was placed when this transaction was made or entered into. Submission of this certification is a prerequisite for making or entering into this transaction imposed by section 1352, title 31, U.S. Code. Any person who fails to file the required certification shall be subject to a civil penalty of not less than \$10,000 and not more than \$100,000 for each such failure.

A18 PROHIBITION of SEGREGATED FACILITIES

A18.1 SOURCE

41 CFR § 60

A18.2 APPLICABILITY

The contractor must comply with the requirements of the E.E.O. clause by ensuring that facilities they provide for employees are free of segregation on the basis of race, color, religion, sex, sexual orientation, gender identity, or national origin. This clause must be included in all contracts that include the equal opportunity clause, regardless of the amount of the contract.

Contract Types – AIP sponsors must incorporate the Prohibition of Segregated Facilities clause in any contract containing the Equal Employment Opportunity clause of 41 CFR §60.1. This obligation flows down to subcontract and sub-tier purchase orders containing the Equal Employment Opportunity clause.

Construction - Construction work means construction, rehabilitation, alteration, conversion, extension, demolition or repair of buildings, highways, or other changes or improvements to real property, including facilities providing utility services. The term also includes the supervision, inspection, and other onsite functions incidental to the actual construction.

Equipment – On site installation of equipment such as airfield lighting control equipment meets the definition of construction and thus this provision would apply. This provision does not apply to equipment projects involving manufacture of the item at a vendor's manufacturing plant. An example would be the manufacture of a SRE or ARFF vehicle.

Professional Services - Professional services that include tasks that qualify as construction work as defined by 41 CFR part 60. Examples include the installation of noise monitoring equipment.

Property/Land - Land acquisition contracts that include tasks that qualify as construction work as defined by 41 CFR part 60. Examples include demolition of structures or installation of boundary fencing.

Use of Provision – The regulation does not prescribe mandatory language, the following language is acceptable to the FAA and meets the intent of this requirement. If the sponsor uses different language, the sponsor's language must fully satisfy the requirements of 41 CFR § 60.

A18.3 CONTRACT CLAUSE

PROHIBITION of SEGREGATED FACILITIES

(a) The Contractor agrees that it does not and will not maintain or provide for its employees any segregated facilities at any of its establishments, and that it does not and will not permit its employees to perform their services at any location under its control where segregated facilities are maintained. The Contractor agrees that a breach of this clause is a violation of the Equal Opportunity clause in this contract.

(b) "Segregated facilities," as used in this clause, means any waiting rooms, work areas, rest rooms and wash rooms, restaurants and other eating areas, time clocks, locker rooms and other storage or dressing areas, parking lots, drinking fountains, recreation or entertainment areas, transportation, and housing facilities provided for employees, that are segregated by explicit directive or are in fact segregated on the basis of race, color, religion, sex, or national origin because of written or oral policies or employee custom. The term does not include separate or single-user rest rooms or necessary dressing or sleeping areas provided to assure privacy between the sexes.

(c) The Contractor shall include this clause in every subcontract and purchase order that is subject to the Equal Opportunity clause of this contract.

A19 OCCUPATIONAL SAFETY AND HEALTH ACT OF 1970

A19.1 SOURCE

20 CFR part 1910

A19.2 APPLICABILITY

Contract Types – All contracts and subcontracts must comply with the Occupational Safety and Health Act of 1970 (OSH). The United States Department of Labor Occupational Safety & Health Administration (OSHA) oversees the workplace health and safety standards wage provisions from OSH.

Use of Provision – The regulation does not prescribe mandatory language. The following language is acceptable to the FAA and meets the intent of this requirement. If the sponsor uses different language, the sponsor's language must fully satisfy the requirements of 20 CFR part 1910.

A19.3 CONTRACT CLAUSE

All contracts and subcontracts that result from this solicitation incorporate by reference the requirements of 29 CFR Part 1910 with the same force and effect as if given in full text. Contractor must provide a work environment that is free from recognized hazards that may cause death or serious physical harm to the employee. The Contractor retains full responsibility to monitor its compliance and their subcontractor's compliance with the applicable requirements of the Occupational Safety and Health Act of 1970 (20 CFR Part 1910). Contractor must address any claims or disputes that pertain to a referenced requirement directly with the U.S. Department of Labor – Occupational Safety and Health Administration.

A20 PROCUREMENT OF RECOVERED MATERIALS

A20.1 SOURCE

2 CFR § 200.322

40 CFR part 247

A20.2 APPLICABILITY

Sponsors of AIP funded development and equipment projects must comply with Section 6002 of the Solid Waste Disposal Act, as amended by the Resource Conservation and Recovery Act. Section 6002 emphasizes maximizing energy and resource recovery through use of affirmative procurement actions for recovered materials identified in the EPA guidelines.

The requirements of § 6002 include procuring only items designated in guidelines of the Environmental Protection Agency (EPA) at 40 CFR part 247 that contain the highest percentage of recovered materials practicable, consistent with maintaining a satisfactory level of competition.

Contract Types – This provision applies to any contracts that include procurement of products where the purchase price of the item exceeds \$10,000 or the value of the quantity acquired by the preceding fiscal year exceeded \$10,000.

Construction and Equipment – Include this provision in all construction and equipment projects

Professional Services and Property – Include this provision if the agreement includes procurement of a product that exceeds \$10,000

Use of Provision – The regulation does not prescribe mandatory language. The following language is acceptable to the FAA and meets the intent of this requirement. If the sponsor uses different language, the sponsor's language must fully satisfy the requirements of 2 CFR § 200.

A20.3 CONTRACT CLAUSE

Procurement of Recovered Materials

Contractor and subcontractor agree to comply with Section 6002 of the Solid Waste Disposal Act, as amended by the Resource Conservation and Recovery Act, and the regulatory provisions of 40 CFR Part 247. In the performance of this contract and to the extent practicable, the Contractor and subcontractors are to use of products containing the highest percentage of recovered materials for items designated by the Environmental Protection Agency (EPA) under 40 CFR Part 247 whenever:

- a) The contract requires procurement of \$10,000 or more of a designated item during the fiscal year; or,

The contractor has procured \$10,000 or more of a designated item using Federal funding during the previous fiscal year.

The list of EPA-designated items is available at www.epa.gov/epawaste/consERVE/tools/cpg/products/.

Section 6002(c) establishes exceptions to the preference for recovery of EPA-designated products if the contractor can demonstrate the item is:

- a) Not reasonably available within a timeframe providing for compliance with the contract performance schedule;
- b) Fails to meet reasonable contract performance requirements; or
- c) Is only available at an unreasonable price.

A21 RIGHT TO INVENTIONS

A21.1 SOURCE

2 CFR § 200, Appendix II(F)

37 CFR §401

A21.2 APPLICABILITY

Contract Types – This provision applies to all contracts and subcontracts with small business firms or nonprofit organizations that includes performance of *experimental, developmental, or research work*. This clause is not applicable to construction, equipment or professional service contracts unless the contract includes *experimental, developmental or research work*.

Use of Provision – The regulation does not prescribe mandatory language. The following language is acceptable to the FAA and meets the intent of this requirement. If the sponsor uses different language, the sponsor's language must fully satisfy the requirements of Appendix II to 2 CFR part 200.

A21.3 CONTRACT CLAUSE

RIGHTS TO INVENTIONS

Contracts or agreements that include the performance of experimental, developmental, or research work must provide for the rights of the Federal Government and the Owner in any resulting invention as established by 37 CFR part 401, Rights to Inventions Made by Non-profit Organizations and Small Business Firms under Government Grants, Contracts, and Cooperative Agreements. This contract incorporates by reference the patent and inventions rights as specified within in the 37 CFR §401.14. Contractor must include this requirement in all sub-tier contracts involving experimental, developmental or research work.

A22 SEISMIC SAFETY

A22.1 SOURCE

49 CFR part 41

A22.2 APPLICABILITY

Contract Types – This provision applies to construction of new buildings and additions to existing buildings financed in whole or in part through the Airport Improvement Program.

Professional Services and Construction – Sponsor must incorporate this clause in any contract involved in the construction of new buildings or structural addition to existing buildings.

Equipment – Sponsor must include this provision if the project involves construction or structural addition to a building such as an electrical vault project.

Land – This provision will not typically apply to a property/land project.

Use of Provision – The regulation does not prescribe mandatory language. The following language is acceptable to the FAA and meets the intent of this requirement. If the sponsor uses different language, the sponsor's language must fully satisfy the requirements of 49 CFR part 41.

A22.3 CONTRACT CLAUSE

A22.3.1 Professional Service Agreements for Design

Seismic Safety

In the performance of design services, the Consultant agrees to furnish a building design and associated construction specification that conform to a building code standard which provides a level of seismic safety substantially equivalent to standards as established by the National Earthquake Hazards Reduction Program (NEHRP). Local building codes that model their building code after the current version of the International Building Code (IBC) meet the NEHRP equivalency level for seismic safety. At the conclusion of the design services, the Consultant agrees to furnish the Owner a "certification of compliance" that attests conformance of the building design and the construction specifications with the seismic standards of NEHRP or an equivalent building code.

A22.3.2 Construction Contracts

Seismic Safety

The contractor agrees to ensure that all work performed under this contract, including work performed by subcontractors, conforms to a building code standard that provides a level of seismic safety substantially equivalent to standards established by the National Earthquake Hazards Reduction Program (NEHRP). Local building codes that model their code after the current version of the International Building Code (IBC) meet the NEHRP equivalency level for seismic safety.

A23 TERMINATION OF CONTRACT

A23.1 SOURCE

2 CFR § 200 Appendix II(B)

FAA Advisory Circular 150/5370-10, Section 80-09

A23.2 APPLICABILITY

Contract Types – All contracts and subcontracts in excess of \$10,000 must address *termination for cause* and *termination for convenience* by the sponsor. The provision must address the manner (i.e. notice, opportunity to cure, and effective date) by which the sponsor's contract will be affected and the basis for settlement (i.e. incurred expenses, completed work, profit, etc.).

Use of Provision –

Termination for Default - Section 80-09 of FAA Advisory Circular 150/5370-10 establishes standard language for Termination for Default under a construction contract. The sponsor must not make any changes to this standard language.

Termination for Convenience – The sponsor must include a clause for termination for convenience. The following language is acceptable to the FAA and meets the intent of this requirement. If the sponsor uses different language, the sponsor's language must fully satisfy the requirements of Appendix II to 2 CFR part 200.

Equipment, Professional Services and Property – The sponsor may use their established clause language provided that it adequately addresses the intent of Appendix II(B) to Part 200, which addresses termination for fault and for convenience.

A23.3 CONTRACT CLAUSE

A23.3.1 Termination for Convenience

Termination for Convenience (Construction & Equipment Contracts)

The Owner may terminate this contract in whole or in part at any time by providing written notice to the Contractor. Such action may be without cause and without prejudice to any other right or remedy of Owner. Upon receipt of a written notice of termination, except as explicitly directed by the Owner,

the Contractor shall immediately proceed with the following obligations regardless of any delay in determining or adjusting amounts due under this clause:

1. Contractor must immediately discontinue work as specified in the written notice.
2. Terminate all subcontracts to the extent they relate to the work terminated under the notice.
3. Discontinue orders for materials and services except as directed by the written notice.
4. Deliver to the owner all fabricated and partially fabricated parts, completed and partially completed work, supplies, equipment and materials acquired prior to termination of the work and as directed in the written notice.
5. Complete performance of the work not terminated by the notice.
6. Take action as directed by the owner to protect and preserve property and work related to this contract that Owner will take possession.

Owner agrees to pay Contractor for:

- a) completed and acceptable work executed in accordance with the contract documents prior to the effective date of termination;

documented expenses sustained prior to the effective date of termination in performing work and furnishing labor, materials, or equipment as required by the contract documents in connection with uncompleted work;

reasonable and substantiated claims, costs and damages incurred in settlement of terminated contracts with Subcontractors and Suppliers; and reasonable and substantiated expenses to the contractor directly attributable to Owner's termination action

Owner will not pay Contractor for loss of anticipated profits or revenue or other economic loss arising out of or resulting from the Owner's termination action.

The rights and remedies this clause provides are in addition to any other rights and remedies provided by law or under this contract.

Termination for Convenience (Professional Services)

The Owner may, by written notice to the Consultant, terminate this Agreement for its convenience and without cause or default on the part of Consultant. Upon receipt of the notice of termination, except as explicitly directed by the Owner, the Contractor must immediately discontinue all services affected.

Upon termination of the Agreement, the Consultant must deliver to the Owner all data, surveys, models, drawings, specifications, reports, maps, photographs, estimates, summaries, and other documents and materials prepared by the Engineer under this contract, whether complete or partially complete.

Owner agrees to make just and equitable compensation to the Consultant for satisfactory work completed up through the date the Consultant receives the termination notice. Compensation will not include anticipated profit on non-performed services.

Owner further agrees to hold Consultant harmless for errors or omissions in documents that are incomplete as a result of the termination action under this clause.

A23.3.2 Termination for Default

Termination for Default (Construction)

Section 80-09 of FAA Advisory Circular 150/5370-10 establishes conditions, rights and remedies associated with Owner termination of this contract due default of the Contractor.

Termination for Default (Equipment)

The Owner may, by written notice of default to the Contractor, terminate all or part of this Contract if the Contractor:

1. Fails to commence the Work under the Contract within the time specified in the Notice- to-Proceed;
2. Fails to make adequate progress as to endanger performance of this Contract in accordance with its terms;
3. Fails to make delivery of the equipment within the time specified in the Contract, including any Owner approved extensions;
4. Fails to comply with material provisions of the Contract;
5. Submits certifications made under the Contract and as part of their proposal that include false or fraudulent statements;
6. Becomes insolvent or declares bankruptcy;

If one or more of the stated events occur, the Owner will give notice in writing to the Contractor and Surety of its intent to terminate the contract for cause. At the Owner's discretion, the notice may allow the Contractor and Surety an opportunity to cure the breach or default.

If within [10] days of the receipt of notice, the Contractor or Surety fails to remedy the breach or default to the satisfaction of the Owner, the Owner has authority to acquire equipment by other procurement action. The Contractor will be liable to the Owner for any excess costs the Owner incurs for acquiring such similar equipment.

Payment for completed equipment delivered to and accepted by the Owner shall be at the Contract price. The Owner may withhold from amounts otherwise due the Contractor for such completed equipment, such sum as the Owner determines to be necessary to protect the Owner against loss because of Contractor default.

Owner will not terminate the Contractor's right to proceed with the Work under this clause if the delay in completing the work arises from unforeseeable causes beyond the control and without the fault or negligence of the Contractor. Examples of such acceptable causes include: acts of God, acts of the Owner, acts of another Contractor in the performance of a contract with the Owner, and severe weather events that substantially exceed normal conditions for the location.

If, after termination of the Contractor's right to proceed, the Owner determines that the Contractor was not in default, or that the delay was excusable, the rights and obligations of the parties will be the same as if the Owner issued the termination for the convenience the Owner.

The rights and remedies of the Owner in this clause are in addition to any other rights and remedies provided by law or under this contract.

Termination for Default (Professional Services)

Either party may terminate this Agreement for cause if the other party fails to fulfill its obligations that are essential to the completion of the work per the terms and conditions of the Agreement. The party initiating the termination action must allow the breaching party an opportunity to dispute or cure the breach.

The terminating party must provide the breaching party [7] days advance written notice of its intent to terminate the Agreement. The notice must specify the nature and extent of the breach, the conditions necessary to cure the breach, and the effective date of the termination action. The rights and remedies in this clause are in addition to any other rights and remedies provided by law or under this agreement.

a) **Termination by Owner:** The Owner may terminate this Agreement in whole or in part, for the failure of the Consultant to:

1. Perform the services within the time specified in this contract or by Owner approved extension;
2. Make adequate progress so as to endanger satisfactory performance of the Project;
3. Fulfill the obligations of the Agreement that are essential to the completion of the Project.

Upon receipt of the notice of termination, the Consultant must immediately discontinue all services affected unless the notice directs otherwise. Upon termination of the Agreement, the Consultant must deliver to the Owner all data, surveys, models, drawings, specifications, reports, maps, photographs, estimates, summaries, and other documents and materials prepared by the Engineer under this contract, whether complete or partially complete.

Owner agrees to make just and equitable compensation to the Consultant for satisfactory work completed up through the date the Consultant receives the termination notice. Compensation will not include anticipated profit on non-performed services.

Owner further agrees to hold Consultant harmless for errors or omissions in documents that are incomplete as a result of the termination action under this clause.

If, after finalization of the termination action, the Owner determines the Consultant was not in default of the Agreement, the rights and obligations of the parties shall be the same as if the Owner issued the termination for the convenience of the Owner.

b) **Termination by Consultant:** The Consultant may terminate this Agreement in whole or in part, if the Owner:

1. Defaults on its obligations under this Agreement;
2. Fails to make payment to the Consultant in accordance with the terms of this Agreement;
3. Suspends the Project for more than [180] days due to reasons beyond the control of the Consultant.

Upon receipt of a notice of termination from the Consultant, Owner agrees to cooperate with Consultant for the purpose of terminating the agreement or portion thereof, by mutual consent. If Owner and Consultant cannot reach mutual agreement on the termination settlement, the Consultant may, without prejudice to any rights and remedies it may have, proceed with terminating all or parts of this Agreement based upon the Owner's breach of the contract.

In the event of termination due to Owner breach, the Engineer is entitled to invoice Owner and to receive full payment for all services performed or furnished in accordance with this Agreement and all justified reimbursable expenses incurred by the Consultant through the effective date of termination action. Owner agrees to hold Consultant harmless for errors or omissions in documents that are incomplete as a result of the termination action under this clause.

A24 TRADE RESTRICTION CERTIFICATION

A24.1 SOURCE

49 USC § 50104

49 CFR part 30

A24.2 APPLICABILITY

Unless waived by the Secretary of Transportation, sponsors may not use AIP funds on a product or service from a foreign country included in the current list of countries that discriminate against U.S. firms as published by the Office of the United States Trade Representative (U.S.T.R)

Contract Types – The trade restriction certification and clause applies to all AIP funded projects.

Use of Provision – 49 CFR part 30 prescribes the language for this model clause. The sponsor must include this certification language in all contracts and subcontracts without modification.

A24.3 CONTRACT CLAUSE

TRADE RESTRICTION CERTIFICATION

By submission of an offer, the Offeror certifies that with respect to this solicitation and any resultant contract, the Offeror -

- a. is not owned or controlled by one or more citizens of a foreign country included in the list of countries that discriminate against U.S. firms as published by the Office of the United States Trade Representative (U.S.T.R.);
- b. has not knowingly entered into any contract or subcontract for this project with a person that is a citizen or national of a foreign country included on the list of countries that discriminate against U.S. firms as published by the U.S.T.R.; and
- c. has not entered into any subcontract for any product to be used on the Federal on the project that is produced in a foreign country included on the list of countries that discriminate against U.S. firms published by the U.S.T.R.

This certification concerns a matter within the jurisdiction of an agency of the United States of America and the making of a false, fictitious, or fraudulent certification may render the maker subject to prosecution under Title 18, United States Code, Section 1001.

The Offeror/Contractor must provide immediate written notice to the Owner if the Offeror/Contractor learns that its certification or that of a subcontractor was erroneous when submitted or has become erroneous by reason of changed circumstances. The Contractor must require subcontractors provide immediate written notice to the Contractor if at any time it learns that its certification was erroneous by reason of changed circumstances.

Unless the restrictions of this clause are waived by the Secretary of Transportation in accordance with 49 CFR 30.17, no contract shall be awarded to an Offeror or subcontractor:

- (1) who is owned or controlled by one or more citizens or nationals of a foreign country included on the list of countries that discriminate against U.S. firms published by the U.S.T.R. or
- (2) whose subcontractors are owned or controlled by one or more citizens or nationals of a foreign country on such U.S.T.R. list or
- (3) who incorporates in the public works project any product of a foreign country on such U.S.T.R. list;

Nothing contained in the foregoing shall be construed to require establishment of a system of records in order to render, in good faith, the certification required by this provision. The knowledge and information of a contractor is not required to exceed that which is normally possessed by a prudent person in the ordinary course of business dealings.

The Offeror agrees that, if awarded a contract resulting from this solicitation, it will incorporate this provision for certification without modification in all lower tier subcontracts. The contractor may rely on the certification of a prospective subcontractor that it is not a firm from a foreign country included on the list of countries that discriminate against U.S. firms as published by U.S.T.R., unless the Offeror has knowledge that the certification is erroneous.

This certification is a material representation of fact upon which reliance was placed when making an award. If it is later determined that the Contractor or subcontractor knowingly rendered an erroneous certification, the Federal Aviation Administration may direct through the Owner cancellation of the contract or subcontract for default at no cost to the Owner or the FAA.

A25 VETERAN'S PREFERENCE

A25.1 SOURCE

49 USC § 47112(c)

A25.2 APPLICABILITY

Contract Types – This provision applies to all AIP funded projects that involve labor to carry out the project. This preference, which excludes executive, administrative and supervisory positions, applies to covered veterans (as defined under §47112(c)) only when they are readily available and qualified to accomplish the work required by the project.

Use of Provision – The regulation does not prescribe mandatory language, the following language is acceptable to the FAA and meets the intent of this requirement. If the sponsor uses different language, the sponsor's language must fully satisfy the requirements of 49 U.S.C. § 47112.

A25.3 CONTRACT CLAUSE

VETERAN'S PREFERENCE

In the employment of labor (excluding executive, administrative, and supervisory positions), the contractor and all sub-tier contractors must give preference to covered veterans as defined within Title 49 United States Code Section 47112. Covered veterans include Vietnam-era veterans, Persian Gulf veterans, Afghanistan-Iraq war veterans, disabled veterans, and small business concerns (as defined by 15 U.S.C. 632) owned and controlled by disabled veterans. This preference only applies when there are covered veterans readily available and qualified to perform the work to which the employment relates.

SECTION III

Special Provisions

For

CONSTRUCT NORTHWEST SERVICE ROAD – PHASE 1

6/7/16



**ILLINOIS PROJECT: MLI-4531
AIP PROJECT: 3-17-0068-XX**

At

**QUAD CITY INTERNATIONAL AIRPORT
MOLINE, ILLINOIS**

June 3, 2016

Prepared By:

Crawford, Murphy and Tilly, Inc.
Consulting Engineers
3300 69th Avenue, Suite 2
Moline, IL 61265
<http://www.cmtengr.com>



15014-06-00

GENERAL

These Special Provisions, together with applicable Standard Specifications, Contract Requirements for Airport Improvement Project, Rules and Regulations, Payroll Requirements and Minimum Wage Rates which are hereto attached or which by reference are herein incorporated, cover the requirements of the State of Illinois, Division of Aeronautics, and the representatives of the Metropolitan Airport Authority of Rock Island County for the improvements at Quad City International Airport, Moline, Illinois.

GOVERNING SPECIFICATIONS AND RULES AND REGULATIONS

The “**Standard Specifications for Construction of Airports**”, State of Illinois, Department of Transportation, Division of Aeronautics, adopted April 1, 2012 shall govern the project except as otherwise noted in these Special Provisions. In the case of conflict with any part or parts of said specifications, the said Special Provisions shall take precedence and shall govern.

Specifications may be obtained at <http://dot.state.il.us/aero/airspecs.html>.

Where referenced within the Special Provisions, the Illinois Department of Transportation Standard Specifications for Road and Bridge Construction adopted April 1, 2016 shall apply.

INDEX TO SPECIAL PROVISIONS

<u>ITEM - DESCRIPTION</u>	<u>PAGE NUMBER</u>
DIVISION I – GENERAL PROVISIONS	3
SECTION 40 – SCOPE OF WORK	3
SECTION 50 – CONTROL OF WORK	5
SECTION 60 – CONTROL OF MATERIALS	7
SECTION 70 – LEGAL RELATIONS AND RESPONSIBILITY TO PUBLIC	9
SECTION 80 – PROSECUTION AND PROGRESS	12
DIVISION II – PAVING CONSTRUCTION DETAILS	14
ITEM 150520 – MOBILIZATION	14
ITEM 152000 – EXCAVATION AND EMBANKMENT	15
ITEM 152531 – EXPLORATION TRENCH	18
ITEM 152540 – SOIL STABILIZATION FABRIC	20
ITEM 156000 – EROSION CONTROL	22
ITEM 208515 – POROUS GRANULAR EMBANKMENT	24
ITEM 209000 – CRUSHED AGGREGATE BASE COURSE	27
ITEM 401000 – BITUMINOUS SURFACE COURSE - SUPERPAVE (METHOD I)	28
ITEM 401900 – REMOVE BITUMINOUS PAVEMENT	30
ITEM 403000 – BITUMINOUS BASE COURSE – SUPERPAVE (METHOD I)	31
ITEM 602000 – BITUMINOUS PRIME COAT	33
ITEM 603000 – BITUMINOUS TACK COAT	34
ITEM 620000 – PAVEMENT MARKING	35
DIVISION IV – DRAINAGE	37
ITEM 701000 – PIPE FOR STORM SEWERS AND CULVERTS	37
ITEM 752000 – CONCRETE CULVERTS, HEADWALLS AND MISC. DRAINAGE STRUCTURES	38

DIVISION V – TURFING	39
ITEM 901000 – SEEDING	39
ITEM 905000 – TOPSOILING	41
ITEM 908000 – MULCHING	43
DIVISION VI - LIGHTING INSTALLATION	45
ITEM 110000 – INSTALLATION OF AIRPORT UNDERGROUND ELECTRICAL DUCT	45
DIVISION VIII - MISCELLANEOUS	47
ITEM 910000 – ROADWAY SIGNAGE	47
IDOT DIVISION OF AERONAUTICS POLICY MEMORANDA	A
IDOT HIGHWAY STANDARDS.....	B
BUY AMERICAN REQUIREMENTS	C

POLICY MEMORANDA – APPENDIX A INDEX

87-2	DENSITY ACCEPTANCE OF BITUMINOUS PAVEMENTS
87-4	DETERMINATION OF BULK SPECIFIC GRAVITY (d) OF COMPACTED BITUMINOUS MIXES
96-1	ITEM 610, STRUCTURAL PORTLAND CEMENT CONCRETE: JOB MIX FORMULA APPROVAL & PRODUCTION TESTING
96-3	REQUIREMENTS FOR QUALITY ASSURANCE ON PROJECTS WITH BITUMINOUS CONCRETE PAVING
97-2	PAVEMENT MARKING PAINT ACCEPTANCE
2003-1	REQUIREMENTS FOR LABORATORY, TESTING, QUALITY CONTROL, AND PAVING OF SUPERPAVE BITUMINOUS CONCRETE MIXTURES FOR AIRPORTS

IDOT HIGHWAY STANDARDS – APPENDIX B INDEX

542301-03	PRECAST REINFORCED CONCRETE FLARED END SECTION
542306-02	CONCRETE ELLIPTICAL FLARED END SECTION
720001-01	SIGN PANEL MOUNTING DETAILS
720011-01	METAL POSTS FOR SIGNS, MARKERS & DELINEATORS
729001-01	APPLICATIONS OF TYPES A & B METAL POSTS (FOR SIGNS & MARKERS)

DIVISION I – GENERAL PROVISIONS

SECTION 40 – SCOPE OF WORK

40-05 MAINTENANCE OF TRAFFIC

ADD:

The Airport will give proper notice to the nearest Flight Service Stations and the Airways Facilities Chief of the Federal Aviation Administration prior to beginning construction.

The Contractor shall consult with the Airport and the Resident Engineer in arranging his construction operations. The Airport will at all times have jurisdiction over the safety of air traffic during construction. Wherever the safety of air traffic during construction is concerned, his decisions as to methods, procedures and measures used shall be final, and any and all Contractors performing work must be governed by such decisions.

Maintenance of Airport Systems is critical to the operation of the Airport and the safety and/ or security of the traveling public. Prior to beginning work the contractor shall investigate existing systems which may be located within the work area and locate all existing utilities. The contractor may seek assistance from the JULIE, Engineer, Resident Engineer, Airport and FAA with locating utilities but the final responsibility for all utility locates lies solely with the contractor. If the contractor's investigation reveals that a utility must be relocated to allow for the performance of the work in the plans, the contractor shall immediately notify the Resident Engineer and remain clear of the utility until resolution has been determined by the Division and the Airport. Any system, including but not limited to systems associated with security, air navigation, weather, airfield lighting damaged by the contractor's operations shall be immediately repaired to the satisfaction of the owner. No delay shall be taken in the repair of the damaged facility. The contractor shall not be allowed to finish work for the day until the utility has been repaired.

The Contractor shall keep all access roads utilized by his operations clean. All access roads shall remain clear and unobstructed for use by airport vehicles. The Contractor shall maintain these areas as required or as directed by the Airport. Should the Contractor fail to respond to the notification, the Division may suspend work until such time as the unsatisfactory condition is corrected.

Access to the site will change throughout the project based on the most current work area—Any damage to existing airfield pavement due to construction traffic operating beyond the approved work areas or access roads for a particular days' work, hauling outside of the approved haul/access routes and construction traffic operating in prohibited areas shall be repaired by the Contractor at his own expense to the satisfaction of the Owner.

To maintain airport operations and to facilitate the construction of the proposed project, the arrangement of the proposed work is shown in the construction activity plans in accordance with Advisory Circular 150/5370-2F Operational Safety on Airports During Construction. References to Construction Safety and Phasing Plans (CSPP) in that document shall be interpreted to mean the work area limits, barricade locations, access points and notes shown on the construction activity plan sheet included in the as-bid contract documents. When "safety" is used or referred to in the contract documents and in the advisory circular(s) it shall be redefined by this contract as meaning "operational safety". The Construction Operational Safety and Phasing Plan (CSPP) establishes the airport and project specific requirements, supplementing the requirements in the AC, that are to be included in the contractor's bid for maintaining operational safety during construction.

The Construction Operational Safety and Phasing Plan (CSPP) contained herein has been approved by both the Airport and the FAA. The contractor shall be required to arrange his/her construction operations in substantial conformance with the CSPP shown in the plans, except as allowed by the contract documents and approved by the Division on behalf of the FAA.

Ten days prior to the preconstruction conference the Contractor shall submit a Safety Plan Compliance Document (SPCD) to the airport describing how he/she will comply with the requirements of the advisory circular plus the CSPP and supplying any details that could not be determined before contract award. The SPCD must include a certification statement by the contractor that indicates he understands the operational safety requirements of the CSPP, that the contractor has incorporated these requirements into their overall work plan and that the contractor will maintain the right of control for all means, methods and details of the work performed by the contractor and any of his subcontractors within the framework of the operational safety plan.

Ten days prior to the preconstruction conference the Contractor shall submit a preliminary plan detailing the intended progression of work to the Airport for review and approval. This plan shall be a working plan. The Contractor shall update the Resident Engineer and the Airport at the end of each day related to their completed work for the day and their intended plan for the following day.

The Contractor shall be fully aware and continuously monitor all requirements and activities for compliance with the contract documents and Advisory Circular 150/5370-2F.

Significant Changes to the Construction Operational Safety and Phasing Plan (CSPP) may require aeronautical review by the Division through the FAA's OEAAA System. Modification of the Construction Operational Safety and Phasing Plan (CSPP) and/ or the critical points shown in the contract documents will require airspace approval from Division/ FAA and may require the contractor to submit FAA Form 7460 for Approval.

The Contractor shall not have access to any part of the active airfield (runway, taxiway or apron) for all equipment or personnel without the approval of the Airport.

The Contractor shall provide his own radio capable of transmitting and receiving ground frequency 122.95 MHz.

The Contractor shall notify the FAA Field Office 72 hours prior to working in NAVAID critical areas or in areas where FAA cables or facilities are located.

The Contractor shall not be entitled to any extra compensation due to delays or inconveniences caused by said necessary methods, procedures, and measures to protect air traffic

SECTION 50 – CONTROL OF WORK

50-04 COOPERATION OF CONTRACTOR

ADD: At the end of this section:

A materials/pre-paving meeting shall be scheduled prior to the start of various paving operations to discuss material acquisition, mixing, placing, testing, etc. The superintendent, paving foreman, batching foreman/material supplier, quality control officer, and the Resident Engineer are required to attend this meeting.

50-06 CONSTRUCTION LAYOUT STAKES

DELETE: The first paragraph.

ADD: As the first paragraph:

The Contractor will be required to furnish and place construction layout stakes for this project.

The Resident Engineer will locate and reference three (3) control points and will establish benchmarks along the line of the improvement outside construction limits. The Contractor shall locate and reference the centerline of survey, which shall also consist of locating and referencing control points such as point of curvature, points of tangent, and sufficient points on tangent to provide a line of sight. Control points set by the Resident Engineer shall be identified in the field to the Contractor, and the field notes shall be kept in the office of the Resident Engineer.

RESPONSIBILITY OF THE RESIDENT ENGINEER

DELETE: Lines A & B.

ADD:

A. The Resident Engineer will locate and reference three (3) control points within the limits of the project.

B. Benchmarks will be established along the project outside of construction lines.

50-13 MAINTENANCE DURING CONSTRUCTION

ADD:

The contractor shall make provisions in the work to maintain positive drainage from the work areas and to minimize the ponding of water. In areas where the contractor is required to core out the contractor shall cut temporary ditches or swales to maintain positive drainage. At locations where temporary ditches are not feasible, the contractor shall excavate storm water storage areas adjacent to but at a lower elevation than the bottom of the work and utilize mechanical pumps to promptly remove storm water from the excavations. All existing pavement areas that are to remain open to aircraft traffic shall be kept clean to the satisfaction of Airport. At the request of the Airport, the Contractor shall provide a self-propelled, vacuum or regenerative (recirculating) air pavement sweeper, a pavement blower or tractor mounted "sweeper box". At a minimum, a pavement blower shall be kept on site at all times.

Material tracked onto public streets shall be removed continuously during the work.

No material capable of being blown onto airfield pavement will be allowed to be stored uncovered anywhere within the fence line, at any time during construction.

50-16 FINAL INSPECTION

DELETE: The first sentence of the first paragraph.

ADD: As the first sentence of the first paragraph.

Upon due notice to the Resident Engineer from the Contractor of presumptive completion of the entire project, the charging of Contract Time shall be suspended and the Engineer will make an inspection.

ADD: After the first sentence of the second paragraph:

The charging of Contract Time shall resume on the day following the inspection and shall continue until the remaining work, including the applicable requirements of Section 40-08, Final Clean-up, is completed to the Engineer's satisfaction.

50-18 PLANS AND WORK DRAWINGS

ADD: After the fourth paragraph:

Submittals shall include items such as: Contractor's, manufacturer's, or fabricator's drawings; descriptive literature including (but not limited to) catalog cuts, diagrams, operating charts or curves; test reports; samples; O&M manuals (including parts list); certifications; warranties; and other such required submittals.

Prior to submission, the Contractor shall review all shop drawing submittals for accuracy, completeness, and compliance with the contract requirements. The Contractor shall stamp, sign and date each submittal indicating Contractor approval of the submittal.

When submittals require close coordination of a number of products, the Contractor shall coordinate a concurrent submittal of all such products. The Project Engineer may withhold action on a submittal requiring coordination with other submittals until all related submittals are received.

Each submittal shall be complete and in sufficient detail to allow ready determination of compliance with contract requirements. Any deviation from contract requirements shall be clearly identified on the shop drawing submittal and supporting documentation for such deviation shall be attached. The Project Engineer reserves the right to rescind inadvertent acceptance of submittals containing unidentified deviations.

REVISE: The second sentence of the seventh paragraph to read as follows:

Such review will not relieve the Contractor of the responsibility for complying with the contract document requirements or for any error that may exist in the submittal. The Contractor is responsible for the dimensions and designs of adequate connections, detail and satisfactory construction of all work.

SECTION 60 – CONTROL OF MATERIALS

60-01 SOURCE OF SUPPLY AND QUALITY REQUIREMENTS

REVISE: The first sentence of the third paragraph as follows:

“ . . shall provide, prior to delivery . . . ”

ADD: At the end of this section:

C. Meets “Buy America” requirements.

The materials used on the work shall be new and conform to the requirements of the specifications. Unless otherwise specified, such materials that are manufactured or processed shall be new (as compared to used or reprocessed).

In order to expedite the inspection and testing of materials, the Contractor shall furnish complete statements to the Owner as to the origin, composition, and manufacture of all materials to be used in the work. Such statements shall be furnished promptly after execution of the contract or with the shop or working drawing submittals but, in all cases, prior to delivery of such materials.

Only FAA approved manufacturers meeting the Buy American preference requirements can provide the FAA approved equipment and materials specified in this document. The manufacturer shall certify in writing, all products are wholly produced in the US of US materials, or Request a waiver to use non-US produced products, or Certify that all equipment that is being used on the project is on the Nationwide Buy American conformance list. Waiver requests shall be obtained prior to the Notice to Proceed is issued

The waiver can be considered if “at least 60% of the cost of the components and subcomponents in the facility or equipment are produced in the United States and the final assembly of the facility or equipment has occurred in the United States.”

In any calculation of Buy American percentage, the labor for the final assembly is excluded. This is because the Buy American statute is based on the cost of materials and equipment, not labor. For a building, this means that only the costs of the materials as they are delivered to the airport site are considered when calculating US and non-US component and subcomponent costs. For equipment, the costs of the final assembly at the manufacturing site are excluded.

The Contractor must request waivers from FAA in writing, with sufficient supporting information. The Contractor is solely responsible for ensuring their waiver request is complete and accurate using project specific information provided directly by the Contractor or the Contractor’s supplier.

The FAA will conduct its review and approval based on the information provided by the grant recipient.

The information that must be provided for equipment shall include but not be limited to:

- Project Number
- Project Name
- Airport Name
- Total Project Cost
- Total Equipment or Bid Item Cost for which the waiver is being requested
- Total Equipment or Bid Item Cost excluding labor for final assembly.
- The equipment or bid item for which the waiver is being requested

- The manufacturer and country of origin of the equipment or bid item.
- The location of the final assembly of the equipment or bid item (not the airport site)
- The cost of the US components and subcomponents for the equipment or bid item for which the waiver is being requested
- The cost of the non-US components and subcomponents for the equipment or bid item for which the waiver is being requested
- The resulting percent of US and non-US components

The Contractor/ manufacturer is urged to submit waiver requests as early as possible.

60-11 CERTIFICATION OF MATERIALS

ADD:

The Contractor shall certify all materials contained in the contract. Certification and documentation shall be submitted to the Resident Engineer. It shall be the sole responsibility of the Contractor to ensure the delivery of adequate and accurate documentation prior to the delivery of materials. Materials incorporated into this project without approved certification and documentation will not be recommended for payment by the Resident Engineer.

It shall be the sole responsibility of the Contractor to provide certification that ALL materials to be used on the project meet the “Buy American” requirements.

The certification shall be submitted as part of the shop drawing submittal.

As a guide to the certification process and requirements, the Contractor shall use the Illinois Department of Transportation/Division of Aeronautics MANUAL FOR DOCUMENTATION OF AIRPORT MATERIALS (latest edition). Copies of this manual are available from the Illinois Division of Aeronautics. The MANUAL FOR DOCUMENTATION OF AIRPORT MATERIALS defines the Resident Engineer’s/Contractor’s responsibilities (Sections 300/400). The Contractor shall have the sole responsibility to provide the Resident Engineer with appropriate documentation to satisfy the contract certification requirements prior to the delivery of materials.

The cost of providing the required material documentation and certifications shall not be paid for separately, but shall be considered incidental to the associated item.

All submittals shall contain the following information:

PROJECT LOCATION: Quad City International Airport
PROJECT TITLE: Construct Northwest Service Road – Phase 1
PROJECT NUMBER: Illinois Project: MLI-4531

CONTRACT ITEM: (i.e., AR156520 – Inlet Protection)
SUBMITTED BY: (Contractor/Subcontractor Name)
DATE: (Date of Submittal)

If the Division of Aeronautics requires additional documentation, they shall request it through the Resident Engineer.

SECTION 70 – LEGAL RELATIONS AND RESPONSIBILITY TO PUBLIC

70-10 BARRICADES, WARNING SIGNS & HAZARD MARKERS

ADD: At the end of the second paragraph:

Any cost for signage or traffic control shall be borne by the Contractor.

Low profile barricades as approved by the FAA shall be provided per the details in the plan sheets. The barricades shall be lighted with steady burn omni-directional red lights supplemented with a 20" x 20" orange flag.

The barricades shall be sufficiently weighted with sandbags or other appropriate method to withstand high winds or jet blast without dislocation.

The barricades must be of low mass and easily collapsible upon contact with an aircraft.

Barricades shall be placed as shown in the plans or as directed by Airport.

The Contractor shall be responsible for supplying, maintaining and any moving of all barricades. Lights shall be maintained in proper working order. No separate payment will be made for supplying, maintaining and moving barricades but shall be considered incidental to the contract.

ADD: At the end of the eighth paragraph:

Mark and identify vehicles in accordance with AC 150/5210-5 (latest revision) *Painting, Marking and Lighting of Vehicles Used on an Airport*. When any vehicle is required to travel over any portion of the aircraft movement area and runway approach area, the vehicle shall be properly identified to operate in the area or provided with a flag on a staff so attached to the vehicle so that the flag will be readily visible. The flag should be not less than 3-foot square consisting of a checkered pattern of international orange and white squares of not less than one foot on each side and displayed in full view above the vehicle. A flag or escort vehicle is not required for vehicles which have been painted, marked and lighted for routine use on aircraft movement areas. Any vehicle operating on the movement area during the hours of darkness should be equipped with an amber flashing dome-type light, in accordance with local and/or state codes.

70-13 RESPONSIBILITY FOR DAMAGE CLAIMS

REVISE: In the second sentence of the first paragraph, change the word "inspection" to "observation".

REVISE: In the last sentence of the fourth paragraph, change the word "inspection" to "observation".

70-17 CONTRACTOR'S RESPONSIBILITY FOR UTILITY SERVICE AND FACILITIES OF OTHERS

REVISE: The second paragraph as follows:

“. . . , the approximate locations and owners have been indicated on the plans.”

DELETE: "Person to Contact" table after the second paragraph.

ADD: After the third paragraph:

The Contractor shall be responsible for locating Airport owned utilities.

REVISE:

The following table includes contact numbers that may provide assistance for locating cable. The personnel listed in the table are in no way responsible for damage to existing utilities.

If, in the Contractor's opinion, additional assistance is needed to locate the utility service or facility, the contractor shall enlist the assistance of a qualified technician or professional utility location firm to accurately locate underground utilities or facilities prior to excavation. Prior to commencing this detailed location work in the general vicinity of an existing utility service or facility, the Contractor shall again notify each such owner of his/her plan of operation and request the presence of a representative of the owner to observe the work. Such notification shall be given by the most expeditious means to reach the utility owner's PERSON TO CONTACT no later than two normal business days prior to the Contractor's commencement of operations in such general vicinity. The Contractor shall furnish a written summary of the notification to the Engineer.

Only after the investigation has been made should the contractor begin excavation operations. Upon beginning these operations, the contractor shall use extreme caution in the methods utilized. The contractor shall utilize exploratory trenching or small tool excavation practices when beginning operations in critical areas to verify that the utilities are clear of the area of interest or to verify the location and depth of these facilities.

QUAD CITY INTERNATIONAL AIRPORT

Utility Service of Facility	Person to Contact	Contact Phone
FAA Control & Communications Cable	Airways Facility Unit	1-309-799-7303
Airfield Lighting Cables	Airport Manager	Arrangement made through Resident Engineer
Electric Cables	J.U.L.I.E.	1-800-892-0123
Telephone Cables	J.U.L.I.E.	1-800-892-0123
Gas Lines	J.U.L.I.E.	1-800-892-0123
Water Lines	J.U.L.I.E.	1-800-892-0123

Any utility damaged by the Contractor shall be repaired by the Contractor to the satisfaction of the Owner and shall be at the cost of the Contractor. In the event that an existing utility is damaged during construction, all other work on the project shall be suspended until the utility is repaired. No additional time will be awarded to the Contractor for delays in the project due to damaged utilities. It is a high priority to the airport that all existing Airport utilities, unless otherwise noted in the plans, remain in good working condition throughout the duration of the project.

Special care shall be taken on all operations and particularly near pavement edges to avoid damage to edge lights and all underground electrical cable on the airport. The approximate location of existing underground cable is shown on drawings. Any airfield lights or cable that are broken and require replacement because of the Contractor's operations will be replaced by the Contractor at his/her own expense.

Any airfield cable repairs or replacement to any part of the electrical system made necessary by the Contractor's operations will be made by him/her in the manner specified in Sections 108 and 125 at no cost to the Airport. Cost of replacement to be borne by the Contractor shall include any expense incurred in locating as well as repairing or replacing damaged parts of the system by the owning agency.

70-26 CONTRACTOR'S RESPONSIBILITY FOR SAFETY DURING CONSTRUCTION

As a minimum, the Contractor shall be responsible for safety during construction as follows:

- (1) Review the requirements in AC 150/5370-2 (current edition) and comply with items listed as contractor's responsibility.
- (2) Implement a CSPP and SPCD as required in AC 150/5370-2 (current edition) and ensure that construction personnel are familiar with operational safety procedures and regulations on the Airport.
- (3) Provide a 24-hour point of contact that will coordinate an immediate response to correct any construction-related activity that may adversely affect the operational safety of the Airport.
- (4) Provide a safety officer/construction inspector(s) trained in airport safety to maintain the CSPP and SPCD and to monitor all construction activities.
- (5) Restrict movement of construction vehicles to construction areas as flagging and barricading, erecting temporary fencing, or providing escorts, as appropriate.
- (6) Ensure that no construction employees, employees of subcontractors or suppliers, or other persons enter any part of the aircraft operations area from construction site unless authorized.

SECTION 80 – PROSECUTION AND PROGRESS

80-05 LIMITATION OF OPERATIONS

A minimum distance of 160' shall be maintained between construction operations and the centerline of all active taxiways and 250' from centerline of active Runway 5/23 and 13/31 and 300' from the centerline of active Runway 9/27 unless otherwise shown in the Plans in the Construction Safety and Phasing Plan. If work occurs within these limits, the pavement shall be closed prior to the work commencing.

It is intended to plan, conduct, and complete the work in these critical traffic areas in such a manner that the length and amount of interruption to aircraft traffic at the Airport is minimized.

The Contractor shall comply with Federal Aviation Regulations and with all rules and regulations of the Airport, including, but not limited to, control and access to the airfield by Contractor's, employees and agents. In the event the Authority is assessed a fine by the Federal Aviation Administration for breach of security resulting from actions of Contractor's employees and agents, the Contractor shall fully reimburse the Authority for the amount of such fine in the form of additional rents.

80-08 DETERMINATION AND EXTENSION OF CONTRACT TIME

ADD: After the fourth paragraph:

The Engineer will make charges against Contract Time after the presumptive completion of the entire project as provided for in Section 50-16, Final Inspection.

80-13 CONTRACTOR'S ACCESS TO AIRFIELD

ADD: After the third paragraph:

The location of parking by the Contractor's employees shall be as shown on the plans or as agreed to by the Airport.

Use of personal vehicles beyond the staging area will not be allowed.

When not in use, the Contractor's vehicles and equipment shall park in the location shown on the plans or in an area outside the Runway Safety Areas (RSAs) and Taxiway Object Free Areas (TOFAs). The Contractor's vehicles and equipment shall not be parked on a closed taxiway or runway. Parking equipment shall not obstruct the clear line of sight by ATCT to any aprons, taxiways, or runways under air traffic control nor obstruct any runway visual aids, signs or navigational aids or penetrate Part 77 surfaces.

80-14 SECURITY DURING CONSTRUCTION

As a minimum, the Contractor shall be responsible for security during construction as follows:

- (1) Visibly delineate his construction zone by placing a line of barricades or flagging around the entire work zone during each work area of the contract.
- (2) Close pavements associated with work scheduled for that day.
- (3) Keep construction personnel inside the work area delineated by barricades

- (4) Ensure that construction personnel are familiar with security procedures and regulations on the Airport.
- (5) Restrict movement of construction vehicles to construction areas as flagging and barricading, erecting temporary fencing, or providing escorts, as appropriate or as shown in plans.
- (6) The Contractor shall be required to maintain security on the Airport as specified or as directed by the Airport.
- (7) The Contractor shall provide a complete list of personnel that will be employed while on site and update the list as needed. The contractor shall limit access to the AOA. The Contractor shall be responsible for monitoring the access gate during work hours. If the Contractor chooses to leave the gate open, then he shall monitor the gate to prevent unauthorized entries.

DIVISION II – PAVING CONSTRUCTION DETAILS

ITEM 150520 – MOBILIZATION

BASIS OF PAYMENT

150-3.1

ADD:

Payment will be made under:

ITEM AR150520 MOBILIZATION – PER LUMP SUM.

ITEM 152000 – EXCAVATION AND EMBANKMENT

DESCRIPTION

152-1.1

ADD:

This item shall consist of excavation and shoulder construction, to the lines and grades shown in the plans and in conformance with the specifications.

All excess excavation material shall be stockpiled at the location shown in the Plans at no additional cost to the contract. Stockpiling shall include combining all separately placed truck loads into one pile, graded to drain and clear of all Part 77 surfaces. Topsoil shall not be intermixed with other materials to the greatest extent possible, but shall be combined into a separate pile.

152-1.2 CLASSIFICATION

DELETE the first and second paragraphs.

152-1.3 CLEAN CONSTRUCTION OR DEMOLITION DEBRIS

PROJECT CONDITIONS

- A. Prior to bidding, the bidder shall make a site visit to become familiar with the current conditions. He shall also determine the accessibility and assess safety measures that will be necessary to perform the contract work.
- B. Material Sampling and Analysis:
 - 1. The Contractor shall provide his own sampling and analysis as required, and in compliance with applicable laws, prior to offsite disposal of all materials. This costs shall be borne by the Contractor at no additional expense to the Owner

REGULATORY REQUIREMENTS

- A. The Contractor shall comply with all applicable local, state and federal laws and regulations with regard to material removal, handling and disposal, and shall pay all assessed costs and fees.
- B. The Contractor shall comply with the Illinois Environmental Protection Act, as amended by Public Act 096-1416 that was signed in to law on July 30, 2010, Public Act 097-0137 that was signed in to law on July 14, 2011, and all applicable amendments of the Illinois Environmental Protection Act.

SUBMITTALS

- A. Contractor shall submit a Construction or Demolition Debris (CCDD) & Soil Removal and Disposal Plan to the Engineer. Submit the following as a minimum:
 - 1. A list of all construction or demolition debris anticipated to be generated requiring disposal.
 - 2. The anticipated quantity (both in tons and in cubic yards) of construction or demolition debris to be disposed of and identification of disposal facility including address and contact information.

3. The anticipated quantity (both in tons and in cubic yards) of surplus soil to be disposed of, and identification of disposal facility including address and contact information.

If further CCDD testing is deemed necessary by the Contractor and/or by the Contractor's chosen disposal facility, as a minimum, the Contractor shall submit the following:

1. Proposed Testing Program to establish that the surplus soil is uncontaminated, for compliance with the requirements of the Illinois Environmental Protection Act. Include details of intended testing program, and rate of sampling (number of samples based on total quantity of surplus soil generated).
2. Credentials of the testing Lab that will perform the testing, and credentials of the Illinois Licensed Professional Engineer or Illinois Licensed Professional Geologist that will complete all required certification forms.
3. Results of the Proposed Testing Program.

GENERAL

- A. The following work shall be included:
 1. Removal, handling and legal offsite disposal of all construction or demolition debris generated from all contract work, considering it to be clean construction or demolition debris (CCDD).
 2. Removal, handling and legal offsite disposal of surplus soil generated from all contract work, considering it to be uncontaminated.
 3. Debris and surplus soil disposal shall include any onsite drying of the material as required, so that the material will pass the paint-filter test as per Method 9095B in USEPA's publication SW 846, prior to transportation.
 4. Any costs and fees for legally-permitted-facilities accepting clean construction or demolition debris (CCDD), and/or uncontaminated surplus soil.
 5. Additional sampling and testing of surplus soil to establish that it is uncontaminated, and certification to that effect by an Illinois Licensed Professional Engineer or an Illinois Licensed Professional Geologist using Form LPC-663, both as required by law and as required by the site accepting the material.
 6. Any other applicable work, costs and fees as required by local, state and federal laws.

MATERIAL CHARACTERIZATION FOR OFFSITE DISPOSAL

- A. Costs for any and all additional testing, sampling, laboratory analysis or any other document that is required by the recipient of the material (disposal site) to establish that the material is uncontaminated, shall be borne by the Contractor at no additional expense to the Owner.

CONSTRUCTION METHODS

152-2.2 EXCAVATION

ADD: ASTM D 698 Standard Proctor shall apply for aircraft weights under 60,000 pounds.

REVISE: The 9th paragraph of this section to read:

In cut areas not requiring porous granular embankment, the top 8" of subgrade shall be compacted to a density of not less than the percentage of the maximum dry density, at optimum moisture, shown in Table 1 as determined by the compaction control tests cited in Division VII for ASTM D 698 (Standard

Proctor) for aircraft weights of less than 60,000 pounds. In cut areas, where abandoned utilities, including duct bank, gas pipe lines, fuel lines, water mains and sewer pipe are encountered, the utilities shall be removed. The cost of removal shall be considered incidental unless it is specifically called out for removal on the plan sheets.

In cut areas, requiring the use of porous granular embankment, the proposed subgrade shall be compacted to the satisfaction of the Resident Engineer.

152-2.10 TOPSOIL

DELETE: The 5th paragraph of this section and REPLACE with:

Any excess excavation material shall be hauled to designated stockpile location at no additional cost to the contract.

152-2.15 DUST CONTROL WATERING

ADD:

This work shall consist exclusively of the control of dust resulting from construction operations and is not intended for use in the compaction of earth embankment.

Dust shall be controlled by the uniform application of sprinkled water and shall be applied as directed by the Resident Engineer, in a manner meeting his approval.

Dust control watering shall not be paid for separately, but shall be considered incidental to the contract.

METHOD OF MEASUREMENT

152-3.3

DELETE: This section.

BASIS OF PAYMENT

152-4.2

ADD:

Topsoil placement, shoulder fill and embankment fill shall not be paid for separately, but shall be included in the unit bid price for "Unclassified Excavation".

Clean Construction or Demolition Debris (CCDD) removal and disposal shall not be paid for separately, but shall be included in the unit bid price for Unclassified Excavation.

152-4.4

DELETE: This section.

Payment will be made under:

ITEM AR152410 UNCLASSIFIED EXCAVATION – PER CUBIC YARD.

ITEM 152531 – EXPLORATION TRENCH

DESCRIPTION

152-1.1

This item shall consist of constructing an exploratory trench for the purpose of locating existing utilities or other obstructions within the construction limits of the proposed improvements as directed by the Engineer. Specifically, this item is to identify the depth of the existing sanitary forcemain, water main, telephone/fiber and electrical utilities at locations where proposed improvements cross to identify if a conflict exists.

The Contractor shall have the option of using mechanical trenching or vacuum excavation equipment for the purposes of locating existing utilities.

EQUIPMENT AND MATERIALS

152-2.1

The locating trench shall be excavated using mechanical trenching equipment.

Vacuum equipment shall be truck mounted with a minimum 1000 cfm vacuum, 15" Hg and 4" hose.

CONSTRUCTION METHODS

152-3.1

Exploratory excavation of the existing utilities is required within two weeks after the time the contract commences. The Contractor shall determine the depth of the existing utilities at critical locations designated in the field by the Resident Engineer.

The location of the trench shall be as directed by the Engineer and shall be 18" minimum in width and not less than 72" in depth measured from the existing ground elevation so as to allow for proper investigation of the trench. When an existing utility or obstruction is encountered, each side of the locating trench shall be excavated to a distance of ten feet to establish the line and grade of the item. Any tile or underdrain disturbed shall be immediately repaired and no surface runoff shall be allowed to enter into the tile or drain.

The depth of the trench shall be as necessary to uncover the existing utilities or other obstructions and of adequate width to allow investigation of the investigated item in the trench.

The exploration trenches shall be excavated at the locations required by the Engineer.

152-3.2

After the trench has been inspected by the Engineer, the excavated material shall be used to backfill the trench. The Contractor shall repair all areas disturbed by the construction of the locating trench to its original condition. The restoration shall include any necessary topsoiling, seeding, fertilizing and mulching or aggregate backfill and compaction under paved areas. All restoration shall conform to the Standard Specifications and/or these Special Provisions.

METHOD OF MEASUREMENT

152-4.1

The locating trench will be measured for payment in lineal feet of actual trench constructed and accepted. The exposure distance of ten feet on either side of the utility or obstruction will not be measured for payment.

The Engineer will not differentiate between mechanical excavation or vacuum excavation for the purpose of measurement.

BASIS OF PAYMENT

152-5.1

The locating trench shall be paid for at the contract unit price per linear foot, which shall be full compensation for all materials, equipment, labor, tools and any necessary incidentals required to complete this item of work. The landscaping including grading and topsoiling required to restore the areas of trenching or aggregate backfill and compaction under paved areas shall not be paid for separately, but shall be considered incidental to this item.

Payment will be made under:

ITEM AR152531 EXPLORATION TRENCH - PER LINEAR FOOT.

ITEM 152540 – SOIL STABILIZATION FABRIC

CONSTRUCTION METHODS

152-3.1

ADD: Soil Stabilization Fabric shall be delivered to the jobsite in such a manner as to facilitate handling and incorporation into the work without damage. Material shall be stored in such a manner as to prevent exposure to direct sunlight and damage by other construction activities.

ADD:

152-3.2

Prior to the installation of the soil stabilization fabric, the application surface shall be cleared of debris and sharp objects. In the case of subgrades, all wheel tracks or ruts in excess of 75 mm (3 inches) in depth shall be graded smooth or otherwise filled with soil to provide a reasonably smooth surface. Soil stabilization fabric may be installed on the application surface either by hand or by mechanical methods, provided that the fabric is not torn or the surface rutted.

152-3.3

Soil stabilization fabric of insufficient width or length to fully cover the specified area shall be lapped, or sewn. The minimum laps for lap only areas are 600 mm (24 inches) and for sewn areas are 100 mm (4 inches). If sewn, the seam strength shall be equal to or exceed the minimum grab tensile strength of the fabric when tested wet.

152-3.4

The crushed aggregate subbase shall be constructed to the width and depth required on the plans. The material shall be back dumped on the fabric in a sequence of operations beginning at the outer edges of the treatment area with subsequent placement towards the middle. Placement of material on the soil stabilization fabric shall be accomplished by spreading dumped material off of previously placed material with a bulldozer blade or endloader, in such a manner as to prevent tearing or shoving of the fabric. Dumping of material directly on the fabric will only be permitted to establish an initial working platform. No vehicles or construction equipment shall be allowed on the fabric prior to placement of the crushed aggregate subbase. The granular material shall be placed to the full required thickness and compacted to the satisfaction of the Resident Engineer before any loaded trucks are allowed on the area covered.

152-3.5

Soil stabilization fabric which is damaged during installation or subsequent placement of granular material due to failure of the Contractor to comply with these provisions, shall be repaired or replaced at the Contractor's expense, including costs of removal and replacement of the granular material. Torn fabric may be patched in place by cutting and placing a piece of the same fabric over the tear. The dimensions of the patch shall be at least 600 mm (2 ft.) larger than the tear in each direction, and shall be weighted or otherwise secured to prevent the granular material from causing lap separation.

BASIS OF PAYMENT

152-5.1

Payment shall be made at the contract unit price for Soil Stabilization Fabric installed on the project. This price shall be full compensation for furnishing all materials, labor, equipment, certification of material properties and any incidentals necessary to install the fabric as shown on the plans and specified herein.

Payment will be made under:

ITEM AR152540 SOIL STABILIZATION FABRIC - PER SQUARE YARD

ITEM 156000 – EROSION CONTROL

DESCRIPTION

156-1.1

ADD:

All entrances to the construction site shall have a stabilized entrance constructed in accordance with Standard IL-630 of the Natural Resources Conservation Service and the current Illinois Urban Manual.

CONSTRUCTION METHODS

156-3.9 INLET PROTECTION

Inlet filter sediment traps shall be placed in all proposed and existing inlets and catch basins as shown on the plans and hay bales placed around as shown, or as directed by the Resident Engineer.

156-3.10

In the event that temporary erosion and pollution control measures are ordered by the Engineer due to the Contractor's negligence or carelessness, the work shall be performed by the Contractor at no additional cost to the Owner.

METHOD OF MEASUREMENT

156-4.2

DELETE: This section.

156-4.3

REVISE: This section to read:

Temporary Seeding and Temporary Mulching shall not be measured for payment, but shall be considered incidental to the contract.

156-4.4

ADD:

The number of Inlet Protection or Ditch Check paid for shall be the number shown in the plans or ordered by the Resident Engineer used to control erosion and satisfactorily completed.

BASIS OF PAYMENT

156-5.1

REVISE: This section to read:

Payment will be made at the contract unit price per linear foot for Silt Fence and per each for Inlet Protection and Ditch Check. These prices shall be full compensation for furnishing all materials for all preparation and installation of these materials, including excavation, placement, tie-down stakes, staples, maintenance and removal and for all labor, equipment, tools, and incidentals necessary to complete this item.

Stabilized construction entrances, concrete washout, temporary seeding and temporary mulching shall not be measured for payment. It shall be considered incidental to the contract.

Payment will be made under:

ITEM AR156510	SILT FENCE – PER LINEAR FOOT.
ITEM AR156511	DITCH CHECK – PER EACH.
ITEM AR156520	INLET PROTECTION – PER EACH.

ITEM 208515 – POROUS GRANULAR EMBANKMENT

DESCRIPTION

208-1.1

ADD:

This work shall consist of furnishing and placing porous granular embankment at the locations shown in the Plans and to repair soft and yielding subgrade as directed by the Engineer. For bidding, an estimate of approximately 10% of the project area was included for this purpose. No change in the unit price bid for this work will be allowed due to an increase or decrease in the quantity required to complete the work.

MATERIALS

208-2.1 UNCRUSHED COARSE AGGREGATE

DELETE: This Entire Section.

208-2.3 GRADATION

DELETE: This Entire Section.

ADD:

When submitting materials for consideration, the Contractor shall provide written certification that the material meets the specified requirements. A written gradation shall also be furnished.

Gradation for Porous Granular Embankment shall be as follows:

Sieve	Percent Passing
3 inch	100
2 ½ inch	90-100
2 inch	45-75
1 ½ inch	0-30
1 inch	0-6
IDOT Gradation	CA-1

CONSTRUCTION REQUIREMENTS

208-3.2 PREPARING UNDERLYING COURSE

DELETE: This Entire Section.

208-3.3 METHODS OF PRODUCTION

DELETE: This Entire Section.

208-3.4 PLACING

DELETE: This Entire Section.

ADD:

The porous granular embankment shall be placed in lifts no greater than one (1) foot thick or as directed by the Engineer. Rolling the top of this replacement material with a vibratory roller meeting the requirements of Section 1101 of the IDOT *Standard Specification for Road and Bridge Construction* should be sufficient to obtain the desired keying or interlock and necessary compaction. The Engineer shall verify that adequate keying has been obtained.

208-3.5 FINISHING AND COMPACTING

DELETE: Fifth sentence, first paragraph.

ADD:

The base shall be compacted to the satisfaction of the Resident Engineer.

Capping aggregate will not be required when embankment meeting the requirements of Section 209 of the Standard Specifications or granular subbase is placed on top of the porous granular embankment. Capping aggregate (two (2) inch depth) meeting the requirements of Section 209 of the Standard Specifications will be required when embankment meeting the requirements of Section 152 of the Standard Specifications is placed on top of the porous granular embankment.

DELETE: Second paragraph.

DELETE: Second sentence, third paragraph and REPLACE with:

When the rolling develops irregularities that exceed 3/8 inch when tested using an acceptable method, the irregular surface shall be loosened, refilled with the same kind of material as that used in constructing the course, and rolled again as required.

METHOD OF MEASUREMENT

208-4.2

DELETE: This Entire Section.

ADD:

The quantity of Porous Granular Embankment shall be the number of cubic yards as measured by the Engineer at the specified thickness of the material placed. If required, the thickness of PGE measured for payment will include the thickness of the capping stone.

The porous granular embankment shall be used as shown and as field conditions warrant at the time of construction. No adjustment in unit price will be allowed for an increase or decrease in quantities.

The Contractor shall furnish approved duplicate load tickets upon which is recorded the net weight of the aggregates in each truck. The Contractor shall submit one (1) load ticket to the Resident Engineer, or his/her duly authorized representative, at the job site when the truck load is incorporated into the base.

BASIS OF PAYMENT

208-5.1

DELETE: Entire Section.

ADD:

Payment for porous granular embankment shall be paid for at the contract unit price per cubic yard, of which price shall be full compensation for the two (2) inch capping stone (if necessary), furnishing, spreading, compacting, watering and all incidentals related to equipment, labor and tools necessary to complete this work.

Payment will be made under:

ITEM AR208515 POROUS GRANULAR EMBANKMENT – PER CUBIC YARD.

ITEM 209000 – CRUSHED AGGREGATE BASE COURSE

MATERIALS

209-2.3 GRADATION

DELETE: Gradation “C” in Table 1.

CONSTRUCTION METHODS

209-3.4 FINISHING AND COMPACTING

ADD:

The base shall be compacted to not less than 100% of maximum density at optimum moisture as determined by compaction control tests specified in Division VII for aircraft with gross weights of 60,000 lbs or less (Standard Proctor ASTM D698).

The Contractor shall submit copies of all density test results for each lift to the Resident Engineer prior to acceptance testing.

DELETE: Second sentence, third paragraph and REPLACE with:

When the rolling develops irregularities that exceed 3/8 inch when tested using an acceptable method, the irregular surface shall be loosened, refilled with the same kind of material as that used in constructing the course, and rolled again as required.

BASIS OF PAYMENT

209-5.1

ADD:

Payment will be made under:

ITEM AR209608 CRUSHED AGG. BASE COURSE – 8” – PER SQUARE YARD.

ITEM 401000 – BITUMINOUS SURFACE COURSE - SUPERPAVE (METHOD I)

(Central Plant Hot Mix)

DESCRIPTION

401-1.1

ADD: The following after the third paragraph of this section:

This project shall utilize Method I for the production, placement and acceptance of the bituminous surface course.

COMPOSITION

401-3.2 JOB MIX FORMULA

ADD: The following after the third paragraph of this section:

Table 1 Superpave Design Criteria for Automobile (Entrance Roads and Parking Lots) shall apply.

CONSTRUCTION METHODS

401-4.12 JOINTS

ADD: The following as the sixth paragraph of this section:

If at any time during the surface course paving operation, it becomes necessary to end a paving lane at a location other than the new finished pavement edge because of ending a day's paving, machinery breakdown, etc., the lane end will be sawed back a sufficient distance to provide a smooth, neat appearing joint from which to resume paving. The sawed face will be painted with a tack coat and this work shall be considered incidental to Item 401, Bituminous Surface Course, and no additional compensation will be allowed.

401-4.14 SHAPING EDGES

ADD: The following as the second paragraph for this section:

All pavement edges, including the pavement ends, must be left in proper alignment, as shown on the plans. This may be accomplished by a trimming method, or, at the Contractor's option, by sawing after the paving has been completed. No additional compensation will be made if the sawing method is used.

401-4.15 ACCEPTANCE TESTING OF HMA MIXES FOR DENSITY

DELETE: All references to Method II for quantities over 2,500 tons.

BASIS OF PAYMENT

401-6.1

Payment will be made under:

ITEM AR401610 BITUMINOUS SURFACE COURSE – PER TON.

ITEM 401900 – REMOVE BITUMINOUS PAVEMENT

DESCRIPTION

401-1.1

ADD: To the second sentence.

The type of material to be removed along with approximate typical pavement section is shown on the plans. Pavement structure information was taken from airport records, data supplied by airport personnel and soil borings. The Contractor shall verify the type and thickness of material to be removed. **No extra compensation will be allowed for any variations in the pavement sections actually encountered.**

CONSTRUCTION METHODS

401-2.1

ADD:

Any damage to the pavement beyond the limits as shown on the plans shall be removed and replaced by the Contractor at his expense. These areas shall be saw cut to a uniform width.

METHOD OF MEASUREMENT

401-3.1

ADD:

If pavement or subgrade material is removed due to negligence on the part of the Contractor, the additional quantity of pavement removal and replacement of subgrade material will not be measured for payment.

BASIS OF PAYMENT

401-5.1

ADD:

Payment will be made under:

ITEM AR401900 REMOVE BITUMINOUS PAVEMENT – PER SQUARE YARD.

ITEM 403000 – BITUMINOUS BASE COURSE – SUPERPAVE (METHOD I)

(Central Plant Hot Mix)

DESCRIPTION

403-1.1

ADD: The following after the third paragraph of this section:

This project shall utilize Method I for the production, placement and acceptance of the bituminous base course.

COMPOSITION

403-3.2 JOB MIX FORMULA (JMF)

ADD: The following after the third paragraph of this section:

Table 1 Superpave Design Criteria for Automobile (Entrance Roads and Parking Lots) shall apply.

CONSTRUCTION METHODS

403-4.11 JOINTS

Add the following paragraph to this section:

At any time during the base course paving operation it becomes necessary to end a paving lane at a location other than the proposed finished pavement edge because of ending a day's paving, machinery breakdown, etc.; the lane end will be sawed back a sufficient distance to provide a smooth, neat appearing joint from which to resume paving. The sawed face will be painted with a tack coat and this work shall be considered incidental to Item 403 Bituminous Base Course, and no additional compensation will be allowed.

403-4.12 SHAPING EDGES

ADD:

All pavement edges, including the pavement ends, must be left in proper alignment as shown on the plans. This may be accomplished by a trimming method or at the Contractor's option by sawing after the paving has been completed. No additional compensation will be made if the sawing method is used.

403-4.15 ACCEPTANCE TESTING OF HMA MIXES FOR DENSITY

DELETE: All references to Method II for quantities over 2,500 tons.

BASIS OF PAYMENT

403-6.1

Payment will be made under:

ITEM AR403610 BITUMINOUS BASE COURSE – PER TON.

ITEM 602000 – BITUMINOUS PRIME COAT

MATERIALS

602-2.1 BITUMINOUS MATERIAL

ADD:

At the Contractor's option, Penetrating Emulsified Prime (PEP) may be used. The use of PEP shall be as outlined in the Standard Specifications for Road and Bridge Construction, Article 406.02.

CONSTRUCTION METHODS

602-3.3 APPLICATION OF BITUMINOUS MATERIAL

ADD: The following to the second paragraph:

Areas worn from hauling operations shall be re-tacked at no additional cost to the Contract.

BASIS OF PAYMENT

602-5.1

ADD:

Payment will be made under:

ITEM AR602510 BITUMINOUS PRIME COAT – PER GALLON.

ITEM 603000 – BITUMINOUS TACK COAT

CONSTRUCTION METHODS

603-3.3 APPLICATION OF BITUMINOUS MATERIAL

ADD: The following to the second paragraph:

Areas worn from hauling operations shall be re-tacked at no additional cost to the Contract.

BASIS OF PAYMENT

603-5.1

ADD:

Payment will be made under:

ITEM AR603510 BITUMINOUS TACK COAT – PER GALLON.

ITEM 620000 – PAVEMENT MARKING

DESCRIPTION

620-1.1

ADD:

Paint shall be of the type and at the location as shown in the plans. Paint shall be waterborne.

MATERIALS

620-2.2 PAINT

ADD:

The paint shall contain no lead, chromium, cadmium or barium.

DELETE: Section (B) Epoxy in its entirety.

CONSTRUCTION METHODS

620-3.7 PAVEMENT MARKING REMOVAL

REVISE this Section to read:

The Contractor shall remove existing markings as shown in the plans or as directed by the Resident Engineer using the water blasting method only.

METHOD OF MEASUREMENT

620-4.1

ADD:

The quantity of permanent markings to be paid for shall be the number of square feet of painting with the specified material **measured only once to apply two coats** (waterborne only) in conformance with the specifications and accepted by the Engineer. No distinction shall be made between paint colors, including black paint, for payment purposes.

Black border shall not require reflective media.

BASIS OF PAYMENT

ADD:

Payment will be made under:

ITEM AR620520 PAVEMENT MARKING – WATERBORNE – PER SQUARE FOOT.

DIVISION IV – DRAINAGE

ITEM 701000 – PIPE FOR STORM SEWERS AND CULVERTS

MATERIALS

701-2.1 GENERAL

DELETE: Entire Section.

ADD:

Pipe shall be of the type and diameter indicated and installed at the locations shown on the plans. Pipe for storm sewers shall be concrete storm sewer pipe Class IV reinforced concrete conforming to ASTM C-76 (with joints meeting ASTM C-361) for circular pipe and conforming to ASTM C-507 (with joints meeting ASTM C-361) for elliptical pipe as called out in the Plans. All joints shall be gasketed.

CONSTRUCTION METHODS

701-3.3 LAYING AND INSTALLING PIPE

ADD:

When sewer installation requires tapping into an existing manhole, the hole shall be cored to allow for appropriate pipe sizing. The word shall be considered incidental to the installation of the pipe.

701-3.10 PIPE REMOVAL

ADD:

Pipe removal under proposed pavement areas shall be backfilled per Section 701-3.5. Openings due to pipe removals at existing drainage structures to remain shall be patched with brick and mortar as directed by the Engineer.

BASIS OF PAYMENT

701-5.1

ADD:

Payment will be made under:

ITEM AR701512	12" RCP, CLASS IV – PER LINEAR FOOT.
ITEM AR701524	24" RCP, CLASS IV – PER LINEAR FOOT.
ITEM AR800890	38"x24" ELLIPTICAL RCP, CL. III – PER LINEAR FOOT

ITEM 752000 – CONCRETE CULVERTS, HEADWALLS AND MISC. DRAINAGE STRUCTURES

DESCRIPTION

752-1.1

ADD:

This item shall also consist of the installation of end section structures as shown on the plans.

Precast reinforced concrete flared end sections shall be in conformance with IDOT Standard 542301-03 and 542306-02.

BASIS OF PAYMENT

752-5.1

ADD:

Payment will be made under:

ITEM AR752412	PRECAST REINFORCED CONC. FES 12" – PER EACH.
ITEM AR752424	PRECAST REINFORCED CONC. FES 24" – PER EACH.
ITEM AR800891	PREC. REINF. CONC. EL. FES 38"X24" – PER EACH.

DIVISION V – TURFING

ITEM 901000 – SEEDING

DESCRIPTION

901-1.1

ADD:

Restoration, seeding and mulching beyond the limits of seeding and mulching shown in the plans (such as lighting, cabling, signage, access roads, haul roads, staging area, storage area) shall be considered incidental to the contract.

MATERIALS

901-2.2 LIME

DELETE: Entire Section.

ADD:

The Contractor has the option to perform a soil test, at their expense, for the on-site or plan specified topsoil sources. If the Contractor proposes an application of lime, the proposal shall be approved by the Engineer. Lime, if used, shall be at no additional costs to the contract.

901-2.3 FERTILIZER

DELETE: The last paragraph and the fertilizer rate table.

ADD:

Fertilizer shall be applied at rates that supply the following amounts of nutrients per acre to the distributed areas of seeding:

<u>NUTRIENTS</u>	<u>POUNDS PER ACRE</u>
Nitrogen Fertilizer Nutrients	90
Phosphorus Fertilizer Nutrients	90
Potassium Fertilizer Nutrients	<u>90</u>
TOTAL	270

The Contractor has the option to perform a soil test, at their expense, to validate that the fertilizer rate specified is suitable for the on-site or plan specified topsoil sources. If the Contractor proposes an alternate mix ratio and weights, the proposal shall be approved by the Engineer. Alternate mix ratio and/or weights shall be at no additional costs to the contract.

CONSTRUCTION METHODS

901-3.2 DRY APPLICATION METHOD

DELETE: Paragraph C. Seeding

ADD:

Grass seed shall be sown at the rate shown in 901-2.1 with a machine that is capable of cutting a slit in the soil free from leaves and debris, placing the seed in the slit and compacting the seed into the soil of the slit in one continuous operation.

The site will be to grade and shaped to the elevations as shown on the plans. The topsoil will be free of clods, stones, roots, sticks, rivulets, gullies, crusting, caking and have a soil particle size of no larger than 1". Seedbed preparation methods shall be approved by the Engineer. Cultivation shall be accomplished at such a time that seeding may occur immediately and without delay. No seeds shall be sown until the Seedbed has been approved by the Engineer.

No seed shall be sown during high winds or when the ground is not in a proper condition for seeding, nor shall any seed be sown until the purity test has been completed for the seeds to be used, and shows that the seed meets the noxious weed seed requirements. All equipment shall be approved by the Engineer prior to being used. Prior to starting work, seeders shall be calibrated and adjusted to sow seeds at the required seeding rate. Equipment shall be operated in a manner to ensure complete coverage of the entire area to be seeded. The Engineer shall be notified forty-eight (48) hours prior to beginning the seeding operations.

901-3.3 WET APPLICATION METHOD

DELETE: Entire Section.

BASIS OF PAYMENT

901-5.1

ADD:

Payment will be made under:

ITEM AR901510 SEEDING – PER ACRE.

ITEM 905000 – TOPSOILING

DESCRIPTION

905-1.1

ADD:

Existing topsoil shall be stripped from excavation and embankment areas and below proposed pavements and stockpiled outside of the grading limits. The surface of all disturbed areas shall be covered with a layer of topsoil to facilitate drainage and the growth of turf.

CONSTRUCTION METHODS

905-3.1 GENERAL

DELETE: The first sentence.

ADD:

A 4 inch minimum layer of topsoil shall be spread evenly over the disturbed areas outside the proposed pavement to facilitate drainage and the growth of turf.

905-3.3 OBTAINING TOPSOIL

DELETE: The third paragraph.

905-3.4 PLACING TOPSOIL

CHANGE:

In the first sentence the word “uniform” to “minimum”.

ADD:

When constructing Item 152, the contractor shall consider the thickness of topsoil to be spread over the compacted surface to ensure that final grade constructed including the topsoil is to the lines and grades shown in the plans.

METHOD OF MEASUREMENT

905-4.1

DELETE: This section.

ADD:

Topsoil shall be measured and paid as specified under Item 152 of these special provisions.

905-4.2

DELETE: This section.

BASIS OF PAYMENT

905-5.1

DELETE: This section.

ADD:

No individual payment will be made for the spreading of topsoil. Topsoiling shall be considered incidental to Item 152.

ITEM 908000 – MULCHING

DESCRIPTION

908-1.1

ADD:

Restoration, seeding and mulching beyond the limits of seeding and mulching shown in the plans (such as lighting, cabling, signage, access roads, haul roads, staging area, storage area) shall be considered incidental to the contract.

MATERIALS

908-2.1 MULCH MATERIAL

REVISE: First sentence to read:

Material used for mulching shall be (D) Hydraulic Mulch – Heavy Duty and (E) Excelsior Blanket as shown in the Plans and as directed by the Engineer.

ADD:

- (e) Excelsior Blanket. Excelsior blanket shall consist of a machine produced mat of wood excelsior of 80 percent, 6 in. (150 mm) or longer fiber length. The wood from which the excelsior blanket is cut shall be properly cured to achieve adequately curled and barbed fibers.

The blanket shall be of consistent thickness, with the fiber evenly distributed over the entire area of the blanket. The excelsior blanket shall be covered on the top side with a 90 day biodegradable extruded plastic mesh netting having an approximate minimum opening of 5/8 x 5/8 in. (16 x 16 mm) to an approximate maximum opening of 2 x 1 in. (50 x 25 mm). The netting shall be substantially adhered to the excelsior blanket by a knitting process using biodegradable thread or by an applied degradable adhesive. The netting shall also be entwined with the excelsior blanket for maximum strength and ease of handling.

The excelsior blanket shall also be according to the following:

<u>Parameter</u>	<u>Value</u>
Minimum Width	24 ± 1 in. (600 ± 25 mm)
Weight (Mass)	0.63 lb/sq yd (0.34 kg/sq m) ± 10 %

The excelsior blanket shall be smolder resistant and shall withstand the following test. The excelsior blanket specimen shall not flame or smolder for more than a distance of 12 in. (300 mm) from a spot where a lighted cigarette is placed on the surface of the blanket.

The manufacturer shall furnish a certification with each shipment of excelsior blanket stating the number of rolls furnished and that the material complies with these requirements.

- (b) Wire Staples are not allowed for use on the project.
- (c) Wood Stakes. Hardwood blanket anchors shall be approximately 7 in. (180 mm) long from neck of hook to tip of anchor. The wood shall not break during installation. The anchor shall have a 1/2 in. (13 mm) curving hook to hold the blanket in place.

CONSTRUCTION METHODS

908-3.1 MULCHING

ADD:

Erosion control blanket shall be placed using excelsior blanket. Within 24 hours of seed placement, blanket shall be placed on the areas specified. Prior to placing the blanket, the areas to be covered shall be relatively free of rocks or clods over 1 1/2 in. (40 mm) in diameter, and sticks or other foreign material which will prevent the close contact of the blanket with the seed bed. If, as a result of rain, the prepared seed bed becomes crusted or eroded, or if eroded places, ruts, or depressions exist for any reason, the Contractor shall rework the soil until it is smooth and reseed such areas which are reworked.

After the area has been properly shaped, fertilized, and seeded, the blanket shall be laid out flat, evenly, and smoothly, without stretching the material. The excelsior blankets shall be placed so that the netting is on the top and the fibers are in contact with the soil. The heavy duty blankets shall be placed so that the heavy duty extruded plastic mesh is on the bottom.

For placement in ditches, the erosion control blanket shall be applied parallel to the centerline of the ditch so that there are no longitudinal seams within 2 ft (600 mm) of the bottom centerline of the ditch. The blanket shall be toed in on the upslope edge and shingled or overlapped with the flow.

On slopes, the blanket shall be applied either horizontally or vertically to the contour, toed in on the upslope edge, and shingled or overlapped with the flow.

When placed adjacent to pavements, blankets shall be toed in along the edge of shoulder.

Anchoring the blankets shall be according to the manufacturer's specifications.

METHOD OF MEASUREMENT

908-4.2

ADD:

Excelsior Blanket to be paid for shall be the number of square yards measured in place and accepted by the Resident Engineer.

BASIS OF PAYMENT

908-5.1

ADD:

Payment will be made at the contract unit price per acre for mulching and per square yard for excelsior blanket. This price shall be full compensation for furnishing all materials and for placing and anchoring the materials, and for all labor, equipment, tools, and incidentals necessary to complete the item.

Payment will be made under:

ITEM AR908510	MULCHING – PER ACRE.
ITEM AR908520	EXCELSIOR BLANKET – PER SQUARE YARD.

DIVISION VI - LIGHTING INSTALLATION

ITEM 110000 – INSTALLATION OF AIRPORT UNDERGROUND ELECTRICAL DUCT

DESCRIPTION

110-1.1

ADD:

This item shall consist of the construction of new split duct at the locations shown in the plans or as directed by the Engineer.

EQUIPMENT AND MATERIALS

110-2.9 SPLIT DUCT

ADD:

The Contractor shall install PVC concrete encased split duct over existing utility services of the appropriate size to accommodate said utility. Split duct will only be required if the existing utility services are not already in conduit. The Contractor shall not order any materials until such time that the existing utilities have been located and a determination made that protection by split duct will be required. As a minimum, the Contractor shall assume 4" split duct to 6" split duct will be required.

Split duct shall be encased in a minimum of 3" of concrete surrounding the PVC split duct. The cost of routing existing cables through the new split ducts and the cost of concrete encasement shall be incidental to the price of split duct.

110-2.10 AGGREGATE BACKFILL

ADD:

Crushed aggregate material conforming to the requirements of Item 208-2.3 Gradation, Table 1 or as approved by the Engineer shall be used for backfill at the pavement crossings for the proposed duct installation. The granular material shall be compacted to not less than 95% of Standard Proctor laboratory density. In lieu of aggregate, the Contractor may substitute Controlled Low Strength Material (CLSM) backfill for those areas requiring aggregate backfill. This substitution must be approved in writing prior to construction and must be completed at no additional cost to the contract. CLSM shall meet the requirements of IDOT *Standard Specifications for Road and Bridge Construction (latest edition)*, Section 593. The CLSM material will be considered incidental to the associated duct item.

CONSTRUCTION METHODS

110-3.5 BACKFILL

ADD:

Crushed Stone conforming to the requirements of Item 208-2.3 Gradation, Table 1 shall be used for backfill at the pavement crossings for the new duct installation. The granular material shall be compacted to not less than 95% of Standard Proctor laboratory density.

METHOD OF MEASUREMENT

110-4.1

DELETE: This Section.

ADD:

The quantity of concrete encased split duct to be paid for shall be the number of lineal feet installed, measured in place, completed, and accepted. The cost of trench excavation and backfill shall not be measured separately for payment, but shall be considered incidental to the respective pay item associated with the work.

BASIS OF PAYMENT

110-5.1

DELETE: Entire Section.

ADD:

Payment will be made at the contract unit price per lineal foot for concrete encased split duct completed and accepted. These prices shall be full compensation for furnishing all materials and for all preparation, assembly, aggregate backfill, backfill, compaction, and installation of these materials, and for all labor, equipment, tools, and incidentals necessary to complete these items.

Topsoiling and seeding of the duct, conduit trench and handholes shall not be paid for separately but shall be considered incidental to the associated duct.

Payment will be made under:

ITEM AR110550 SPLIT DUCT – PER LINEAR FOOT.

DIVISION VIII - MISCELLANEOUS

ITEM 910000 – ROADWAY SIGNAGE

DESCRIPTION

910-1.1

This item shall consist of furnishing sign panels complete with reflectorized sign faces, legend and supplemental panels and installing them on newly erected sign supports as detailed in the plans at the locations shown or as directed by the Resident Engineer.

Work shall be in accordance with Section 720 and Section 729 of the Standard Specifications for Road and Bridge Construction and with IDOT Standards 720001-01, 720011-01 and 729001-01.

MATERIALS

910-2.1

Materials shall meet the requirements of Sections 720 and 729 of the Standard Specifications for Road and Bridge Construction. Sign panels shall be as detailed in the plans.

CONSTRUCTION METHODS

910-3.1

This work shall consist of furnishing and installing metal posts of the size and type specified, utilizing the direct burial methods, or attaching sign panels to existing light standards as detailed in the plans.

910-3.2

Materials shall meet the requirements of Article 729 of the Standard Specifications for Road and Bridge Construction. Unless otherwise specified, only galvanized posts shall be used. The post shall be Type B as designated on Illinois Department of Transportation Highway Standard 720011-01 and 729001-01.

910-3.3

The metal posts may be driven by hand or mechanical means to a minimum depth of 8 feet (Type B) measured from the ground line or as shown in the plans. The post shall be protected by suitable driving cap and if required by the Engineer, the material around the post will be compacted after driving.

Care shall be taken to avoid scratching, chipping or other damage to polyester or enamel-coated posts during handling and installation. Chips and scratches may be recoated in the field by a method meeting the coating manufacturer's recommendations except that chips and scratches totaling more than 5% of the surface area of any one post and/or more than 5% of the surface area in any one-foot segment of any one post shall be cause for rejection of the post.

If the post specified is too long, the Contractor may choose to cut the post to the required length. Any post so cut shall be installed with the cut end at the bottom.

METHOD OF MEASUREMENT

910-4.1

The quantity of roadway signs installed to be paid shall be the number, per each, of signs satisfactorily installed in accordance with applicable specifications and accepted by the Engineer. Sign posts and supports shall be incidental to this item. No additional compensation shall be made for additional length of posts required.

For purposes of measurement, no distinction shall be made with regards to the size of the sign panels.

BASIS OF PAYMENT

910-5.1

Payment will be made at the contract unit price for ROADWAY SIGNAGE, per each. This price shall be full compensation for all materials and erection of all signs at proposed locations and for all materials, labor and equipment necessary to complete the work as described herein.

Payment will be made under:

ITEM AR910200 ROADWAY SIGN – PER EACH.

IDOT DIVISION OF AERONAUTICS POLICY MEMORANDA

State of Illinois
Department of Transportation
Division of Aeronautics

POLICY MEMORANDUM

February 20, 2014

Springfield

Number: 87-2

TO: CONSULTING ENGINEERS

SUBJECT: DENSITY ACCEPTANCE OF BITUMINOUS PAVEMENTS

I. Introduction

This Policy Memorandum deals with the implementation of the bituminous density quality assurance specifications as outlined in the Standard Specifications for Construction of Airports, Sections 401-4.15 and 403-4.15.

II. Sampling

After completion of compaction and when the pavement has reached ambient temperature, the paved area shall be divided into Sublots of 500 tons per type of mix. One core sample (2 cores per sample) shall be taken from each Sublot. The longitudinal and transverse location for each sample shall be determined by use of a random number "Deck" provided by the Division. No core shall be taken closer than two (2) feet from the edge of the mat. A core extraction device shall be used to obtain all cores from the mat. All cores are to be taken by the contractor under the supervision and remain in the possession of the Engineer. It is imperative that the Engineer and the contractor realize that the cores are "money" and that improper coring, extraction, shipping and/or testing can be costly.

One mix sample per 1000 tons of mix laid shall be taken for Extraction, Maximum Specific Gravity (G_{mm}) and Air Void tests. The mix samples shall be sampled by the contractor and split in half.

The Resident Engineer shall randomly designate and send the split samples to an independent laboratory for testing. The laboratory will be verified to be ASTM- certified for all the required testing and be contracted through the Consultant. The frequency of testing split samples shall be 1 per 5000 tons. Higher frequencies may be necessary if the contractor's tests, and/or mix quality control are inconsistent.

III. Testing

All cores shall be tested for Bulk Specific Gravity (G_{mb}) in accordance with ASTM D2726 using Procedure 10.1, "For Specimens That Contain Moisture." The Theoretical Maximum Gravity (G_{mm}) shall be determined according to ASTM D2041. From these tests the in-place air voids of the compacted pavement are calculated according to ASTM

D3203 for "dense bituminous paving mixtures." Selection of the proper G_{mm} shall be based on a running average of four (4) tests per Lot.

- E.g. Lot 1 - Use the average of the two (2) tests for Lot 1.
 Lot 2 - Use the average of the four (4) tests from Lots 1 and 2.
 Lot 3 - Use the average of the four (4) tests from Lots 2 and 3.

NOTE: When more than four (4) Sublots are used, still use a running average of four (4) tests per Lot.

IV. Acceptance Calculations

The first step in calculating the quantities for pay is to calculate the Mean (\bar{X}) and the Standard Deviation (S) of the Sublot tests. From this data the Lot samples should first be tested for outliers. After consideration for outliers, the Percent Within Tolerance (PWT) and the Percent Within Limits (PWL) are calculated to determine the final pay quantities for the Lot.

EXAMPLE

1. Test Data

Lot Quantity = 2000 tons
 Sublot Test 1 = 4.35 % Air Voids
 Sublot Test 2 = 3.96 % Air Voids
 Sublot Test 3 = 6.75 % Air Voids
 Sublot Test 4 = 6.25 % Air Voids

2. Calculating the Mean and Standard Deviation

Sublot	\bar{X}	$(\bar{X} - \bar{X})$	$(\bar{X} - \bar{X})^2$
1	4.35	-0.978	0.956
2	3.96	-1.368	1.871
3	6.75	1.422	2.022
4	<u>6.25</u>	0.922	<u>0.850</u>
Sum =	21.31		5.699

$$N = 4$$

$$\text{Mean } \bar{X} = 21.34 / 4 = 5.328$$

$$\text{Variance } (S)^2 = \frac{\text{Sum } (\bar{X} - \bar{X})^2}{3} = \frac{5.699}{3} = 1.900$$

$$\text{Standard Deviation } S = \sqrt{1.900} = 1.378$$

3. Test for Outliers

Check for Critical "T" Values

$$T = \frac{|(X_1 - \bar{X})|}{S} = \frac{|3.96 - 5.328|}{1.378} = 0.99$$

* Difference between the suspect test value (X_1) and the Mean (\bar{X}).

If the T value exceeds the critical "T" Value in the table below and no assignable cause can be determined for the outlier, discard the suspected test measurement and obtain another random sample from the Sublot in question. If the new test exceeds the Mean (\bar{X}) in the same direction from the Mean as the suspected test, recalculate the T value including all tests (original test, suspected test, and new test) for an outlier and for computing final payment.

TABLE OF CRITICAL "T" VALUES

Number of observations (N)	Critical "T" Value 5% Significance Level
3	1.15
4	1.46
5	1.67
6	1.82
7	1.94
8	2.03
9	2.11
10	2.18
11	2.23
12	2.29

Based on the above table, the "T" value of 0.99 does not exceed the Critical "T" Value of 1.46 for N = 4. Therefore, the value (3.96) is not an outlier and shall be used in calculating the Lot payment.

4. Calculation of Lot Payment

To calculate the Lot Payment use the Acceptance Criteria as outlined under Item 401-4.15(c) or Item 403-4.15(c).

$$Q_L = \frac{(\bar{X} - 1)}{S} = \frac{5.328 - 1}{1.378} = 3.141$$

$$Q_U = \frac{(7 - \bar{X})}{S} = \frac{7 - 5.328}{1.378} = 1.213$$

From this data the Percentage Within Tolerance (PWT) for both the lower and upper tolerance limits is determined by Table 6 (see Item 401 Bituminous Surface Course and/or Item 403 Bituminous Base Course in the Standard Specifications) for the number (N) of samples tested.

Eq. PWT (lower) = 99.0%
PWT (upper) = 90.4%

We now calculate the Percent Within Limits (PWL) for the Lot.

$$PWL = [PWT (lower)] + [PWT (upper)] - 100$$

$$PWL = (99.0 + 90.4) - 100 = 89.4\%$$

Using Table 5, the % Adjustment in Lot Quantity is:

$$\% \text{ Adjustment} = 0.5 \text{ PWL} + 55.0$$

$$\% \text{ Adjustment} = 0.5 (89.4) + 55.0$$

$$\% \text{ Adjustment} = 99.7$$

$$\text{Adjusted Quantities} = \% \text{ Adjustment} \times \text{Lot Quantities}$$

$$\text{Adjusted Quantities} = 0.997 \times 2000 \text{ tons}$$

$$\text{Adjusted Quantities} = 1994 \text{ tons}$$

5. Resampling and Retesting

The contractor has the right to request the resampling and retesting of a complete Lot. This privilege is only allowed once for each Lot and must be requested in writing by the contractor within 48 hours of receiving the official report from the Engineer.

6. Reporting

After completion of the tests for each Lot, the Engineer shall complete the necessary calculations for final adjustment in quantities on the Form AER-1 and have both the Engineer and the Contractor sign the report for copying to both the FAA and IDOA.

Steven J. Long, P.E. Acting Chief Engineer

Supersedes Policy Memorandum 87-2, dated April 1, 2010

State of Illinois
Department of Transportation
Division of Aeronautics

POLICY MEMORANDUM

February 20, 2014

Springfield

Number: 87-4

TO: CONSULTING ENGINEERS

SUBJECT: DETERMINATION OF BULK SPECIFIC GRAVITY (d) OF COMPACTED BITUMINOUS MIXES

A. SCOPE

This method of test covers the determination of the bulk specific gravity and the percent air, of core samples from compacted bituminous mixtures using a saturated surface-dry procedure.

B. DEFINITIONS

1. Bulk Specific Gravity (G_{mb}) ASTM 2726 or density is the weight per unit volume (gms/cc) of a mixture in its existing state of consolidation. The volume measurement for this specific gravity will include the volume of all the aggregate, asphalt, and air spaces (voids) in the aggregate particles and between the aggregate particles.
2. Theoretical Maximum Specific Gravity (G_{mm}) ASTM 2041 is the weight per unit volume (grams/cc) of a mixture assuming complete consolidation; i.e., all the air spaces (voids) between the aggregate particles are eliminated.
3. Percent Density is a measure of the degree of compaction in relation to the Theoretical Maximum Specific Gravity.
4. Percent Air is a measure of the air voids in the compacted pavement.

C. APPARATUS

1. Balance - The balance shall be accurate to 0.1 gm throughout the operating range. It may be mechanical or electrical and shall be equipped with a suitable suspension apparatus and holder to permit weighing of the core in water while suspended from the balance. If the balance is a beam type, it shall be set up so that the core is placed in the basket that is suspended from the zero (0) end of the balance arm.
2. Water bath - The container for immersing the core in water while suspended from the balance shall be equipped with an overflow outlet for maintaining a constant water level. This water bath should be large enough to handle full-depth cores. When testing several cores at the same time, a dish-pan, sink or suitable container may be used for soaking.

D. PROCEDURE

1. Prior to testing, cores shall be sorted on a flat surface in a cool place. The sample(s) shall be brushed with a wire brush and/or other suitable means, to remove all loose and/or foreign materials, such as seal coat, tack coat, foundation material, soil, paper and foil prior to testing.
2. If a core contains binder and surface or multiple lifts, the lifts shall be separated. This may be done in the following manner:
 - a. Mark the separation line between the two lifts.
 - b. Place the core in a freezer for 20-25 minutes.
 - c. Place a 2 or 3-inch wide chisel on the separation line and tap with a hammer. Rotate the core and continue this process until the core separates. Brush loose pieces with a wire brush if needed.
 - d. Allow 2-3 hours for the core to return to ambient temperature before proceeding.
3. Prepare the water baths for soaking and weighing with water at 77° F. Water baths should be maintained at this temperature throughout testing. Saturate the cores by submerging in the water for a minimum of 20 minutes.
4. With the balance and water bath properly assembled and zeroed, suspend the sample from the balance and submerge it in the water bath. The core must be placed with the original top and bottom in a vertical position. If necessary, add sufficient water to bring the water level up to the overflow outlet. Permit any excess to overflow. Read and record the Saturated Submerged Weight. Designate this weight as (C).
5. Remove the core from the water bath and blot the excess water from the surface of the core with an absorbent cloth or other suitable material. This must be done quickly to prevent the internal water from escaping.
6. Place the core on the balance and read and record the Saturated Surface-dry Weight in air. Designate this weight as (B).
7. Place the core in a tared pan and dry in an oven. When the core is dry (less than 0.5 gm loss in one hour), record the weight and subtract the pan weight. Designate this weight as (A).
8. The following calculation is used to determine the Bulk Specific Gravity of the core.

$$G_{mb} = \frac{A}{B - C}$$

G_{mb} = Bulk Specific Gravity

A = Oven dry weight

B = Saturated surface-dry weight

C = Saturated submerged weight

E. PERCENT DENSITY

The following calculation is used to determine the percent density of the core:

$$\% \text{ Density} = 100 \times \frac{G_{mb}}{G_m}$$

G_{mb} = Bulk Specific Gravity

G_{mm} = Theoretical Maximum Gravity*

Note: The Theoretical Maximum Gravity (G_{mm}) is determined from the mix design until current Vacuum Pycnometer test are available.

F. PERCENT AIR. To calculate the percent air, use the following formula:

$$\% \text{ Air} = 100 - \% \text{ Density}$$

G. WEIGHT PER SQUARE YARD OF COMPACTED MIXTURE. The actual weight per square yard of a compacted mixture can be calculated by using the Bulk Specific Gravity (G_{mb}). The volume of a square yard of pavement one (1) inch thick is 0.75 cubic foot. Taking the weight of a cubic foot of water as 62.37 pounds, one square yard of compacted material, one (1) inch thick weighs:

$$\text{Pounds / Sq. Yd. (1" thick)} = 0.75 \times 62.37 \times G_{mb}$$

Steven J. Long, P.E. Acting Chief Engineer

Supersedes Policy Memorandum 87-4, dated January 1, 2004

State of Illinois
Department of Transportation
Division of Aeronautics

POLICY MEMORANDUM

April 1, 2010

Springfield

Number 96-1

TO: CONSULTING ENGINEERS

SUBJECT: ITEM 610, STRUCTURAL PORTLAND CEMENT CONCRETE:
JOB MIX FORMULA APPROVAL & PRODUCTION TESTING.

- I. This policy memorandum addresses the Job Mix Formula (JMF) approval process and production testing requirements when Item 610 is specified for an airport construction contract.
- II. PROCESS
 - a. The contractor may submit a mix design with recent substantiating test data or he may submit a mix design generated by the Illinois Division of Highways with recent substantiating test data for approval consideration. The mix design should be submitted to the Resident Engineer.
 - b. The Resident Engineer should verify that each component of the proposed mix meets the requirements set forth under Item 610 of the *Standard Specifications for Construction of Airports* and/or the contract special provisions.
 - c. The mix design should also indicate the following information:
 1. The name, address, and producer/supplier number for the concrete.
 2. The source, producer/supplier number, gradation, quality, and SSD weight for the proposed coarse and fine aggregates.
 3. The source, producer/supplier number, type, and weight of the proposed flyash and/or cement.
 4. The source, producer/supplier number, dosage rate or dosage of all admixtures.
 - d. After completion of Items b and c above, the mix with substantiating test data shall be forwarded to the Division of Aeronautics for approval. Once the mix has been approved, the production testing shall be at the rate in Section III as specified herein.

III. PRODUCTION TESTING

- a. One set of cylinders or beams, depending on the strength specified, shall be cast for acceptance testing for each day the mix is used. In addition, at least one slump and one air test shall be conducted for each day the mix is used. If more than 100 c.y. of the mix is placed in a given day, additional tests at a frequency of 1 per 100 c.y. shall be taken for strength, slump, and air. The concrete shall have a maximum slump of three inches (3") and minimum slump of one inch (1") when tested in accordance with ASTM C-143. The air content of the concrete shall be between 5% and 8% by volume. At no time shall the temperature of the concrete exceed 90 degrees Fahrenheit.
- b. If the total proposed amount of Item 610 Structural Portland Cement Concrete as calculated by the Resident Engineer is less than 50 c.y. for the entire project, the following shall apply:
 - The Resident Engineer shall provide calculations of the quantity of Item 610 to the Division of Aeronautics.
 - One set of cylinders or beams, depending on the strength specified, shall be cast for acceptance testing.
 - One air content and one slump test shall be taken for acceptance testing.
 - The concrete shall have a maximum slump of three inches (3") and minimum of one inch (1") when tested in accordance with ASTM C-143. The air content of the concrete shall be between 5% and 8% by volume. At no time shall the temperature of the concrete exceed 90 degrees Fahrenheit.
- c. The Resident Engineer shall collect actual batch weight tickets for every batch of Item 610 concrete used for the project. The actual batch weight tickets shall be kept with the project records and shall be available upon request of the Department of Transportation.

Steven J. Long, P.E.
Acting Chief Engineer

Supersedes Policy Memorandum 96-1 dated January 1, 2004

State of Illinois
Department of Transportation
Division of Aeronautics

POLICY MEMORANDUM

February 20, 2014

Springfield, Illinois

Number 96-3

TO: CONSULTING ENGINEERS

SUBJECT: REQUIREMENTS FOR QUALITY ASSURANCE ON PROJECTS WITH
BITUMINOUS CONCRETE PAVING

I. SCOPE

The purpose of this policy memorandum is to define to the Consulting Engineer the requirements concerning Quality Assurance on bituminous concrete paving projects. Specifically, this memo applies whenever the Contractor is required to comply with the requirements set forth in Policy Memorandum 2003-1, "*Requirements for Laboratory, Testing, Quality Control, and Paving of Bituminous Concrete Mixtures*".

II. LABORATORY APPROVAL

The Resident Engineer shall review and approve the Contractor's plant laboratory to assure that it meets the requirements set forth in the contract specifications and Policy Memorandum 2003-1. This review and approval shall be completed prior to utilization of the plant for the production of any mix.

III. QUALITY ASSURANCE DURING PRODUCTION PAVING

- A. At the option of the Engineer, independent assurance tests may be performed on split samples taken by the Contractor for Quality Control testing. In addition, the Resident Engineer shall witness the sampling and splitting of these samples at the start of production and as needed throughout mix production. The Engineer may select any or all split samples for assurance testing. These tests may be performed at any time after sampling. The test results will be made available to the Contractor as soon as they become available.
- B. The Resident Engineer may witness the sampling and testing being performed by the Contractor. If the Resident Engineer determines that the sampling and Quality Control tests are not being performed according to the applicable test procedures, the Engineer may stop production until corrective action is taken. The Resident Engineer will promptly notify the Contractor, both verbally and in writing, of observed deficiencies. The Resident Engineer will document all witnessed samples and tests. The Resident Engineer may elect to obtain samples for testing, separate from the Contractor's Quality Control process, to verify specification compliance.

1. Differences between the Contractor's and the Engineer's split sample test results will be considered acceptable if within the following limits:

<u>Test Parameter</u>	<u>Acceptable Limits of Precision</u>
% Passing	
1/2 in.	5.0 %
No. 4	5.0 %
No. 8	3.0 %
No. 30	2.0 %
No. 200	2.2 %
Asphalt Content	0.3 %
Maximum Specific Gravity (G_{mm}) of Mixture	0.026
Bulk Specific Gravity (G_{mb}) of Gyratory Brix	0.045

2. In the event a comparison of the required plant test results is outside the above acceptable limits of precision, split or independent samples fail the control limits, an extraction indicates non-specification mix, or a continual trend of difference between Contractor and Engineer test results is identified, the Engineer will immediately investigate. The Engineer may suspend production while the investigation is in progress. The investigation may include testing by the Engineer of any remaining split samples or a comparison of split sample test results on the mix currently being produced. The investigation may also include review and observation of the Contractor's technician performance, testing procedure, and equipment. If a problem is identified with the mix, the Contractor shall take immediate corrective action. After corrective action, both the Contractor and the Engineer shall immediately resample and retest.

- C. The Contractor shall be responsible for documenting all observations, records of inspection, adjustments to the mixture, test results, retest results, and corrective actions in a bound hardback field book or bound diary which will become the property of IDA upon completion and acceptance of the project. The Contractor shall be responsible for the maintenance of all permanent records whether obtained by the Contractor, the Contractor's Consultants, or the producer of bituminous mix material. The Contractor shall provide the Engineer full access to all documentation throughout the progress of the work.

Results of adjustments to mixture production and tests shall be recorded in duplicate and sent to the Engineer.

IV. ACCEPTANCE BY ENGINEER

Density acceptance shall be performed according to Policy Memorandum 87-2, or according to the acceptance procedure outlined in the Special Provisions.

Steven J. Long, P.E. Acting Chief Engineer

Supersedes Policy Memorandum 96-3, dated January 1, 2004

State of Illinois
Department of Transportation
Division of Aeronautics

POLICY MEMORANDUM

January 1, 2004

Springfield, Illinois

Number 97-2

TO: CONSULTING ENGINEERS

SUBJECT: PAVEMENT MARKING PAINT ACCEPTANCE

I. SCOPE

The purpose of this policy memorandum is to define the procedure for acceptance of pavement marking paint.

II. RESIDENT ENGINEER'S DUTIES

The Resident Engineer shall follow the acceptance procedure outlined as follows:

- A. Require the painting contractor to furnish the name of the paint manufacturer and the batch number proposed for use prior to beginning work. Notify the I.D.A. Materials Certification Engineer when this information is available.
- B. Require the manufacturer's certification before painting begins. Check the certification for compliance to the contract specifications.
 1. The certification shall be issued from the manufacturer and shall include the specification and the batch number.
 2. The paint containers shall have the manufacturer's name, the specification and the batch number matching the certification.
- C. If no batch number is indicated on the certification or containers, sample the paint according to the procedure for the corresponding paint type.
- D. If the I.D.A. Engineer of Materials indicates that batch number has not been previously sampled and tested, sample the paint according to the procedure for the corresponding paint type. The Division of Aeronautics will provide paint cans upon request by the Resident Engineer. Samples will only be taken in new epoxy lined cans so that the paint will not be contaminated. It is important to seal the sample container immediately with a tight cover to prevent the loss of volatile solvents.

Mark the sample cans with the paint color, manufacturer's name, and batch number. The paint samples and manufacturer's certification shall be placed in the mail within 24 hours after sampling. Address the samples to the Materials Certification Engineer at:

Illinois Department of Transportation
Division of Aeronautics
One Langhorne Bond Drive
Springfield, Illinois 62707

Sampling Procedures for Each Paint Type:

1. Waterborne or Solvent Base Paints
 - a. Take the paint sample from the spray nozzle when the contractor begins marking. A sample consists of two one-pint cans taken per batch number.
 - b. Be sure to indicate to the contractor that acceptance of material is based upon a passing test of the paint material.

2. Epoxy Paint
 - a. Take separate one-pint samples of each paint component prior to marking. Before drawing samples, the contents of each component's container must be thoroughly mixed to make certain that any settled portion is fully dispersed. **Do not combine the two components or sample from the spray nozzle.**
 - b. Be sure to indicate to the contractor that acceptance of material is based upon a passing test of the paint material.

III. TESTING

The paint will be tested for acceptance by the IDOT Bureau of Materials and Physical Research for conformance to the contract specifications.

Steven J. Long, P.E.
Acting Chief Engineer

Supersedes policy memorandum 97-2 dated February 27, 2002

State of Illinois
Department of Transportation
Division of Aeronautics

POLICY MEMORANDUM

June 12, 2014

Springfield, Illinois

Number 2003-1

TO: CONTRACTORS

SUBJECT: REQUIREMENTS FOR LABORATORY, TESTING, QUALITY CONTROL, AND PAVING OF SUPERPAVE HMA CONCRETE MIXTURES FOR AIRPORTS

I. SCOPE

The purpose of this policy memorandum is to define to the Contractor the requirements concerning the laboratory, testing, Quality Control, and paving of HMA mixtures utilizing Superpave technology. References are made to the most recent issue of the Standard Specifications for Construction of Airports (Standard Specifications) and to American Society for Testing and Materials (ASTM) testing methods. The Quality Assurance and acceptance responsibilities of the Resident Engineer are described in Policy Memorandum 96-3.

II. LABORATORY

The Contractor shall provide a laboratory located at the plant and approved by the Illinois Division of Aeronautics (IDA). The laboratory shall be of sufficient size and be furnished with the necessary equipment and supplies for adequately and safely performing the Contractor's Quality Control testing as well as the Resident Engineer's acceptance testing as described in Policy Memorandum 87-2.

The effective working area of the laboratory shall be a minimum of 600 square feet with a ceiling height of not less than 7.5 feet. Lighting shall be adequate to illuminate all working areas. It shall be equipped with heating and air conditioning units to maintain a temperature of 70° F ±5° F.

The laboratory shall have equipment that is in good working order and that meets the requirements set forth in the following ASTM test standards:

ASTM D 70	Test Method for Specific Gravity and Density of Semi-Solid Materials
ASTM C 117	Test Method for Materials Finer than 75 µm (No. 200) Sieve in Mineral Aggregates by Washing
ASTM C 136	Sieve or Screen Analysis of Fine and Coarse Aggregate
ASTM C 566	Total Moisture Content of Aggregate by Drying
ASTM D 75	Sampling Aggregates
ASTM D 2041	Theoretical Maximum Specific Gravity and Density of Bituminous Paving Mixtures

ASTM D 2172	Quantitative Extraction of Bitumen from Bituminous Paving Mixtures
AASHTO T 308-09	Ignition Method for Determining Asphalt Content (Illinois Modified)
ASTM D 2726	Bulk Specific Gravity of Compacted Bituminous Mixtures using Saturated Surface Dry Specimens
ASTM D 3203	Percent Air Voids in Compacted Dense and Open Bituminous Paving Mixtures
ASTM D 2950	Density of Bituminous Concrete in Place by Nuclear Method
ASTM D 4125	Asphalt Content of Bituminous Mixtures by Nuclear Method
ASTM C 127	Standard Test Method for Specific Gravity and Absorption of Coarse Aggregate
ASTM C 128	Standard Test Method for Specific Gravity and Absorption of Fine Aggregate

The laboratory and equipment furnished by the Contractor shall be properly calibrated and maintained. The Contractor shall maintain a record of calibration results at the laboratory. The Engineer may inspect measuring and testing devices at any time to confirm both calibration and condition. If the Engineer determines that the equipment is not within the limits of dimensions or calibration described in the appropriate test method, he may stop production until corrective action is taken. If laboratory equipment becomes inoperable or insufficient to keep up with mix production testing, the Contractor shall cease mix production until adequate and/or sufficient equipment is provided.

III. MIX DESIGN SUBMITTAL

Based upon data and test results submitted by the Contractor, the Illinois Division of Aeronautics Engineer of Construction & Materials shall issue the final Job Mix Formula (JMF) approval letter that concurs or rejects the Contractor's proposed JMF. The Contractor will be required to perform the sampling and laboratory testing and develop a complete mix design, according to the following guidelines: Mix design submittals should be sent to IDA, Construction/Material Section, Attn: Certification and Mixtures Engineer. Note: Quality Control (QC) Managers shall be Level III QC/QA qualified and will be responsible for all mix designs. All Technicians obtaining samples and performing gradations shall have successfully completed the IDOT Mixture Aggregate Technician Course and Technicians performing mix design testing and plant sampling/testing shall have successfully completed the IDOT Bituminous Concrete Level 1 Technician Course under the Illinois Department of Transportation, Bureau of Materials & Physical Research QC/QA Training Program.

A. Preliminary Mix Design Submittal

Top half of the IDOT Mix Design Software Cover Sheet (QC/QA Package) should be completed for the aggregate mix design parameters and should include the following:

1. Producer name, Producer # and Producer location of each aggregate (Producers are assigned Producer numbers by IDOT Central Bureau of Materials)
2. Material code for each aggregate

3. Aggregate Gradations per ASTM C-136 (The Contractor shall obtain representative samples of each aggregate)
4. Material code for each aggregate (i.e. 022CM11, etc.)
5. Proposed Aggregate Blend (% for each aggregate) Note: Based on the gradation results, the Contractor shall select the blend percentages that comply with the Standard Specifications, Section 401/403 – 3.2 JOB MIX FORMULA, Table 2. (Appendix A)
6. Producer name, Producer #, and specific gravity of the proposed asphalt cement
7. IDOT approved PG Binder 64-22 shall be used unless otherwise specified by the IDA Engineer of Construction & Materials.

B. Mixture Design & Testing

Design Parameters

Gyrations (N_{des}) – per Standard Specifications, Section 401/403 – 3.2 (JMF), Table 1

Asphalt Content – AC% per Standard Specifications, Section 401/403 – 3.2 (JMF), Table 2

Maximum Specific Gravity – G_{mm} (ASTM D 2041)

Bulk Specific Gravity – G_{mb} (ASTM D 2726)

% air voids – V_a (ASTM D3203) per Standard Specifications, Section 401/403 – 3.2 (JMF), Table 2

VFA % – per Standard Specifications, Section 401/403 – 3.2 (JMF), Table 1

Mixture Tests

After verification and approval by IDA of the proposed design information from step A., the Contractor shall perform mixture tests on 4 gyratory brix (4 point mix design) to determine the optimum AC content for the target Air Voids.

C. Mix Design Submittal

The Preliminary JMF including all test results shall be reported to IDA, Construction/Material Section, Attn: Certification and Mixtures with the following data:

- a) Aggregate & asphalt cement material codes
- b) Aggregate & asphalt cement producer numbers, names, and locations
- c) Percentage of each individual aggregate
- d) Aggregate blend % for each sieve
- e) AC Specific Gravity
- f) Bulk Specific Gravity and Absorption for each aggregate
- g) Summary of Superpave Design Data: AC % Mix, G_{mb} , G_{mm} , VMA, Voids (Total Mix), Voids Filled, V_{be} , P_{be} , P_{ba} , G_{se}
- h) Optimum design data listing: AC % Mix, G_{mb} , G_{mm} , VMA, Voids (Total Mix), Voids Filled, G_{se} , G_{sb}

- i) Percent of asphalt that any RAP will add to the mix
- j) Graphs for the following: gradation on 0.45 Power Curve, AC vs. Voids (Total Mix), AC vs. Specific Gravities, AC vs. Voids Filled, AC vs. VMA

D. Mix Approval

Once the proposed JMF is reviewed and approved by IDA, a JMF approval letter will be issued to the contractor. Production of HMA is not authorized until a JMF letter has been issued. When a Test Section is specified as part of the contract, the proposed JMF shall be considered preliminary until it passes all Test Section requirements.

E. Change in Material Sources

The above procedure, III. MIX DESIGN SUBMITTAL shall be repeated for each change in source or gradation of materials.

IV. MIX PRODUCTION TESTING

The Quality Control of the manufacture and placement of HMA mixtures is the responsibility of the Contractor. The Contractor shall perform or have performed the inspection and tests required to assure conformance to contract requirements. Quality Control includes the recognition of defects and their immediate correction. This may require increased testing, communication of test results to the plant or the job site, modification of operations, suspension of HMA production, rejection of material, or other actions as appropriate. The Resident Engineer shall be immediately notified of any failing tests and subsequent remedial action. Form AER M-14 shall be reported to IDA, Construction/Material Section, Attn: Certification and Mixtures Engineer and the Resident Engineer no later than the start of the next work day. The Contractor shall provide a Quality Control (QC) Manager who will have overall responsibility and authority for Quality Control. This individual shall have successfully completed the IDOT Division of Highways HMA Concrete Level II Technician Course "HMA Proportioning and Mixture Evaluation." In addition to the QC Manager, the Contractor shall provide sufficient and qualified personnel to perform the required visual inspections, sampling, testing, and documentation in a timely manner.

- A. Gradations for Mixture Proportioning: Aggregate gradations for proportioning (ASTM C-136) are required at a minimum of one per week when mix is produced. Aggregate gradations can be either hot bin gradations for batch plants or stockpile gradations for drier drum plants. Hot bin gradations may be reported on either form AER 9 or on the Division of Highways QC/QA package "Grad 1" Tab in the Daily HMA Plant Reporting Module. Stockpile gradations shall be shown on form MI504QC from the "Print Out" Tab in the Aggregate Stockpile Module of The Division of Highways QC/QA Package.
- B. Production Mixture Testing: 1 per 1000 tons of the following (if total daily quantity is \leq 200 tons (small quantity) then a mix sample is not required and this quantity may be added on to next day's total for testing. Two consecutive days without testing is not allowed.): Reflux extraction (ASTM D2172) or Ignition oven test showing gradation and AC Content, Maximum Specific Gravity (ASTM D 2041), Bulk Specific Gravity (ASTM D 2726) and % Air Voids (ASTM D 3203). Calculations of the results (including weight data) shall be shown on the "Voids 1" and "IGN & NUC AC 1" tab printouts from the Division of Highways QC/QA Package Daily HMA Plant Reporting module.

- C. A certification from the quarry for the total quantity of aggregate listing the source, gradation type, and quality designation of aggregate shipped. The Aggregate Certification of Compliance (AER18) may be used by the contractor for this purpose.
- D. Original asphalt shipping tickets listing the source and type of asphalt shipped.
- E. Check sample tests at a rate of 1/5000 tons randomly selected by the R.E. shall be sent with an identification sheet to an independent laboratory designated by the Division of Aeronautics. If the project is < 5000 tons, 1 sample selected randomly shall be sent.
- F. Bituminous Test Summary (AER 14) Note: The R.E. should make certain that the Contractor fills this form out daily (for mix production days) and distributes it daily to the Division of Aeronautics and R.E. The Contractor (QC Manager) is required to note any adjustments to the mix or to the plant (proportioning) in the "Remarks/Corrective Measures" section of the AER 14.

V. QUALITY CONTROL

- A. Control Limits (Control Charts used for projects > 4000 tons per bituminous concrete pay item)

Target values shall be determined from the approved JMF. The target values shall be plotted on the control charts within the following control limits:

Control Limits

<u>Parameter</u>	<u>Individual Test</u>	<u>Moving Avg. of 4</u>
% Passing		
1/2 in.	± 7 %	±4 %
No. 4	±7 %	±4 %
No. 8	±5 %	±3 %
No. 30	±4 %	±2.5 %
No. 200 *	±2.0 % *	±1.0 % *
Asphalt Content	±0.45 %	±0.2 %

* No. 200 material percent's shall be based on washed samples. Dry sieve gradations (-200) shall be adjusted based on anticipated degradation in the mixing process.

- B. Control Charts (Control Charts used for projects > 4000 tons per bituminous concrete pay item)

Standardized control charts shall be maintained by the Contractor at the field laboratory. The control charts shall be displayed and be accessible at the field laboratory at all times for review by the Engineer. The individual required test results obtained by the Contractor shall be recorded on the control chart immediately upon completion of a test, but no later than 24 hours after sampling. Only the required plant tests and resamples shall be recorded on the control chart. Any additional testing of check samples may be used for controlling the Contractor's processes, but shall be documented in the plant diary.

The results of assurance tests performed by the Resident Engineer will be posted as soon as available.

The following parameters shall be recorded on control charts:

1. Combined Gradation of Hot-Bin (Batch Plant) or Combined Belt Aggregate Samples (Drier Drum Plant) (% Passing 1/2 in., No. 4., No. 8, No. 30, and No. 200 Sieves)
2. Asphalt Content
3. Bulk Specific Gravity (G_{mb})
4. Maximum Specific Gravity of Mixture (G_{mm}) C.

Corrective Action for Required Plant Tests

Control Limits for each required parameter, both individual tests and the average of four tests, shall be exhibited on control charts. Test results shall be posted within the time limits previously outlined.

1. Individual Test Result. When an individual test result exceeds its control limit, the Contractor shall immediately resample and retest. If at the end of the day no material remains from which to resample, the first sample taken the following day shall serve as the resample as well as the first sample of the day. This result shall be recorded as a retest. If the retest passes, the Contractor may continue the required plant test frequency. Additional check samples should be taken to verify mix compliance.
2. Asphalt Content. If the retest for asphalt content exceeds control limits, mix production shall cease and immediate corrective action shall be instituted by the Contractor. After corrective action, mix production shall be restarted, the mix production shall be stabilized, and the Contractor shall immediately resample and retest. Mix production may continue when approved by the Engineer. The corrective action shall be documented.

Inability to control mix production is cause for the Engineer to stop the operation until the Contractor completes the investigation identifying the problems causing failing test results.

3. Combined Aggregate/Hot-Bin. For combined aggregate/hot-bin retest failures, immediate corrective action shall be instituted by the Contractor. After corrective action, the Contractor shall immediately resample and retest. The corrective action shall be documented.
 - a. Moving Average. When the moving average values trend toward the moving average control limits, the Contractor shall take corrective action and increase the sampling and testing frequency. The corrective action shall be documented.

The Contractor shall notify the Engineer whenever the moving average values exceed the moving average control limits. If two consecutive moving average values fall outside the moving average control limits, the

Contractor shall cease operations. Corrective action shall be immediately instituted by the Contractor. Operations shall not be reinstated without the approval of the Engineer. Failure to cease operations shall subject all subsequently produced material to be considered unacceptable.

- b. Mix Production Control. If the Contractor is not controlling the production process and is making no effort to take corrective action, the operation shall stop.

VI. TEST SECTION AND DENSITY ACCEPTANCE (**Note: Applies only when specified.**)

- A. The purpose of the test section is to determine if the mix is acceptable and can be compacted to a consistent passing density.

A quick way to determine the compaction of the mix is by the use of a nuclear density gauge in the construction of a growth curve. An easy way to construct a growth curve is to use a good vibratory roller. To construct the curve, an area the width of the roller in the middle of the mat is chosen and the roller is allowed to make one compaction pass. With the roller stopped some 30 feet away, a nuclear reading is taken and the outline of the gauge is marked on the pavement. The roller then makes a compaction pass in the opposite direction and another reading is taken. This scenario is continued until at least two (2) passes are made past the maximum peak density obtained.

The maximum laboratory density potential of a given mix is a direct function of the mix design air voids. Whereas, the actual maximum field density is a function of the type of coarse aggregates, natural or manufactured sands, lift thickness, roller type (static or vibratory), roller and paver speed, base condition, mix variation, etc. All of these items are taken into consideration with the growth curve.

1. High Density in the Growth Curve. If the growth curve indicates a maximum achievable field density of between 95 to 98 percent of the Theoretical Maximum Density (D), you can proceed with the Rolling Pattern. On the other hand, if the maximum achievable density is greater than 98 percent, a quick evaluation (by use of an extractor, hot bin gradations, nuclear asphalt determination, etc.) must be made of the mix. When adjustments are made in the mix, a new growth curve shall be constructed.
2. Low Density in the Growth Curve. If the growth curve indicates the maximum achievable density is below 94 percent, a thorough evaluation of the mix, rollers, and laydown operations should be made. After a thorough evaluation of all factors (mix, rollers, etc.), asphalt or gradation changes may be in order as directed by the Engineer. Again, any changes in the mix will require a new growth curve. Note that the nuclear density test is a quality control tool and not an acceptance test. All acceptance testing is to be conducted by the use of cores, unless otherwise specified.

3. Acceptance of Test Section. The Contractor may proceed with paving the day after the test section provided the following criteria have been met:
 - a. Four random locations (2 cores per location cut longitudinally and cored by the Contractor) will be selected by the Engineer within the test strip. All the cores must show a minimum of 94% density.
 - b. All Superpave and extraction test results from mix produced for the test section must be within the tolerances required by specification.
 - c. The Contractor shall correlate his nuclear gauge to the cores taken in the test section. Additional cores may be taken at the Contractor's expense for this purpose within the test section area, when approved by the Engineer.

4. Density Acceptance under Production Paving. The responsibility for obtaining the specified density lies with the Contractor. Therefore, it is important that the nuclear density gauge operator communicate with the roller operators to maintain the specified density requirements. The Contractor shall provide a qualified HMA Density Tester who has successfully completed the Department's "HMA Nuclear Density Testing Course" to run all required density tests on the job site. Density acceptance testing, unless otherwise specified, is described as follows:
 - a. The Contractor shall cut cores at random locations within 500 ton sublots as directed by the Resident Engineer.
 - b. The cores should be extracted so as not to damage them, since they are used to calculate the Contractor's pay.
 - c. The Engineer will run preliminary G_{mb} tests on the cores to give the Contractor an indication of how compaction is running for the next day's paving.
 - d. A running average of four (4) Maximum Theoretical Gravities (G_{mm}) will be used for calculating percent compaction.
 - e. Final core density tests and pay calculations will be performed by the Resident Engineer and delivered to the Contractor.
 - f. Should the contractor wish to resample the pavement as a result of pay calculations resulting in less than 100% payment the request must be made within 48 hours of receipt of the original payment calculation.

Steven J. Long, P.E. Acting Chief Engineer

Supersedes Policy Memorandum 2003-1 dated May 1, 2014

APPENDIX A

AGGREGATE BITUMINOUS BASE COURSE

Percentage by Weight Passing Sieves
Job Mix Formula (JMF)

Sieve Size	Gradation B Range 1" Maximum	Ideal Target
1-1/4 in.	---	---
1 in.	100	100
3/4 in.	93 – 97	95
1/2 in.	75 – 79	77
3/8 in.	64 – 68	66
No. 4	45 – 51	48
No. 8	34 – 40	37
No. 16	27 – 33	30
No. 30	19 – 23	21
No. 100	6 – 10	8
No. 200	4 – 6	5
Bitumen %:		
Stone	4.5 – 7.0	5.5

AGGREGATE BITUMINOUS SURFACE COURSE

Percentage by Weight Passing Sieves
Job Mix Formula (JMF)

Sieve Size	Gradation B Range ¾" Maximum	Ideal Target
1 in.	100	---
¾ in.	100	100
½ in.	99 - 100	100
⅜ in.	91 - 97	94
No. 4	56 – 62	59
No. 8	36 - 42	39
No. 16	27 - 32	30
No. 30	19 - 25	22
No. 100	7 – 9	8
No. 200	5 – 7	6

Bitumen %:		
Stone	5.0 – 7.0	6.0

IDOT HIGHWAY STANDARDS

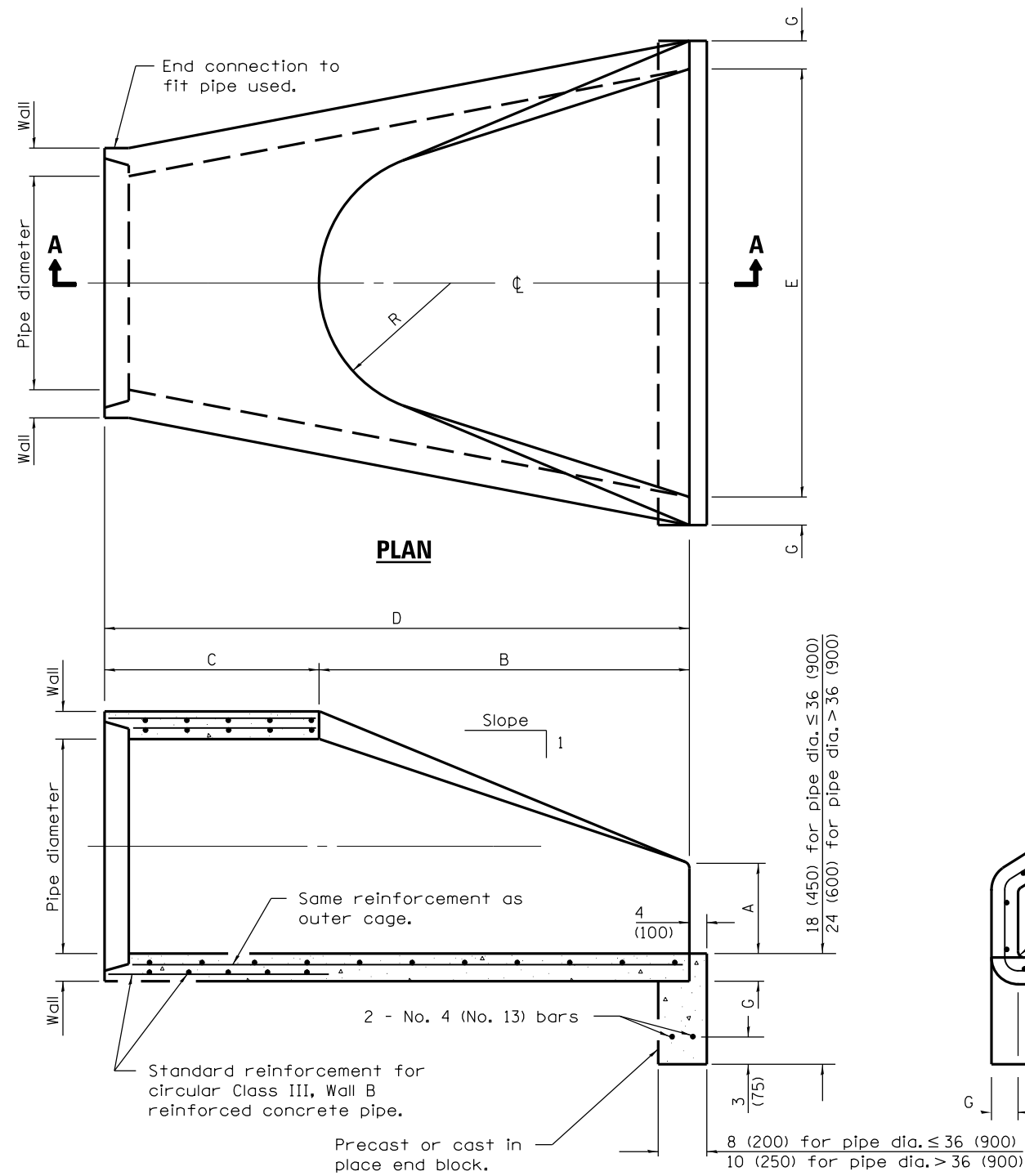

SECTION A-A

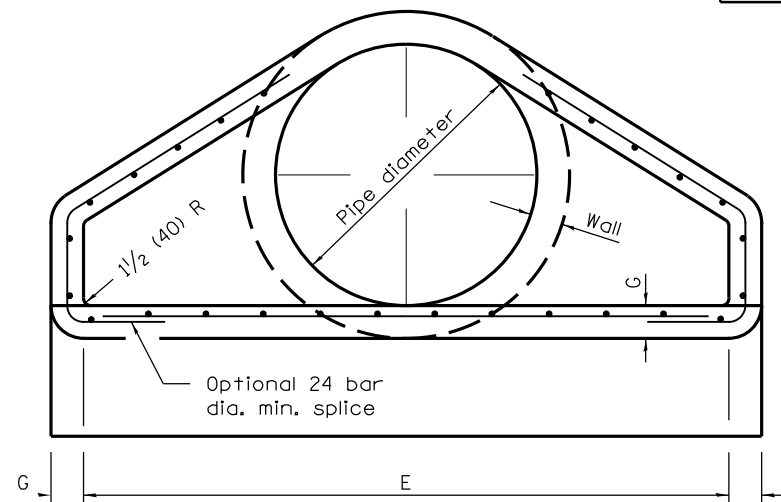

END VIEW

PIPE DIA.	APPROX. QTY. lbs. (kg)	WALL	A	B	C	D	E	G	R	APPROX. SLOPE
12 (300)	530 (240)	2 (51)	4 (102)	24 (610)	4'-0 7/8" (1.241 m)	6'-0 7/8" (1.851 m)	24 (610)	2 (51)	9 (229)	1:2.4
15 (375)	740 (335)	2 1/4 (57)	6 (152)	27 (686)	3'-10" (1.168 m)	6'-1" (1.854 m)	30 (762)	2 1/4 (57)	11 (280)	1:2.4
18 (450)	990 (450)	2 1/2 (64)	9 (229)	27 (686)	3'-10" (1.168 m)	6'-1" (1.854 m)	36 (914)	2 1/2 (64)	12 (305)	1:2.4
21 (525)	1280 (580)	2 3/4 (70)	9 (229)	35 (889)	38 (965)	6'-1" (1.854 m)	3'-6" (1.067 m)	2 3/4 (70)	13 (330)	1:2.4
24 (600)	1520 (690)	3 (76)	9 1/2 (241)	3'-7 1/2" (1.105 m)	30 (762)	6'-1 1/2" (1.867 m)	4'-0" (1.219 m)	3 (76)	14 (356)	1:2.5
27 (675)	1930 (875)	3 1/4 (83)	10 1/2 (267)	4'-0" (1.219 m)	25 1/2 (648)	6'-1 1/2" (1.867 m)	4'-6" (1.372 m)	3 1/4 (83)	14 1/2 (368)	1:2.4
30 (750)	2190 (995)	3 1/2 (89)	12 (305)	4'-6" (1.375 m)	19 3/4 (502)	6'-1 3/4" (1.874 m)	5'-0" (1.524 m)	3 1/2 (89)	15 (381)	1:2.5
33 (825)	3200 (1450)	3 3/4 (95)	13 1/2 (343)	4'-10 1/2" (1.486 m)	39 1/4 (997)	8'-1 3/4" (2.483 m)	5'-6" (1.676 m)	3 3/4 (95)	17 1/2 (445)	1:2.5
36 (900)	4100 (1860)	4 (102)	15 (381)	5'-3" (1.6 m)	34 3/4 (883)	8'-1 3/4" (2.483 m)	6'-0" (1.829 m)	4 (102)	20 (508)	1:2.5
42 (1050)	5380 (2440)	4 1/2 (114)	21 (533)	5'-3" (1.6 m)	35 (889)	8'-2" (2.489 m)	6'-6" (1.981 m)	4 1/2 (114)	22 (559)	1:2.5
48 (1200)	6550 (2970)	5 (127)	24 (610)	6'-0" (1.829 m)	26 (660)	8'-2" (2.489 m)	7'-0" (2.134 m)	5 (127)	22 (559)	1:2.5
54 (1350)	8240 (3740)	5 1/2 (140)	27 (686)	5'-5" (1.651 m)	35 (889)	8'-4" (2.54 m)	7'-6" (2.286 m)	5 1/2 (140)	24 (610)	1:2.0
60 (1500)	8730 (3960)	6 (152)	35 (889)	5'-0" (1.524 m)	39 (991)	8'-3" (2.515 m)	8'-0" (2.438 m)	5 (127)	*	1:1.9
66 (1650)	10710 (4860)	6 1/2 (165)	30 (762)	6'-0" (1.829 m)	27 (686)	8'-3" (2.515 m)	8'-6" (2.591 m)	5 1/2 (140)	*	1:1.7
72 (1800)	12520 (5680)	7 (178)	36 (914)	6'-6" (1.981 m)	21 (533)	8'-3" (2.514 m)	9'-0" (2.743 m)	6 (152)	*	1:1.8
78 (1950)	14770 (6700)	7 1/2 (191)	36 (914)	7'-6" (2.286 m)	21 (533)	9'-3" (2.819 m)	9'-6" (2.896 m)	6 1/2 (165)	*	1:1.8
84 (2100)	18160 (8240)	8 (203)	36 (914)	7'-6 1/2" (2.299 m)	21 (533)	9'-3 1/2" (2.832 m)	10'-0" (3.048 m)	6 1/2 (165)	*	1:1.6

* Radius as furnished by manufacturer

GENERAL NOTES

All slope ratios are expressed as units of vertical displacement to units of horizontal displacement (V:H).

All dimensions are in inches (millimeters) unless otherwise shown.

Illinois Department of Transportation

APPROVED January 1, 2011
Ralph E. Anderson
 ENGINEER OF BRIDGES AND STRUCTURES

APPROVED January 1, 2011
Scott Schick
 ENGINEER OF DESIGN AND ENVIRONMENT

ISSUED 1-1-97

DATE	REVISIONS
1-1-11	Clarified ref. to pipe dia. on Section A-A. Changed 'inner' to 'outer' cage ref.
1-1-09	Switched units to English (metric).

PRECAST REINFORCED CONCRETE FLARED END SECTION

STANDARD 542301-03

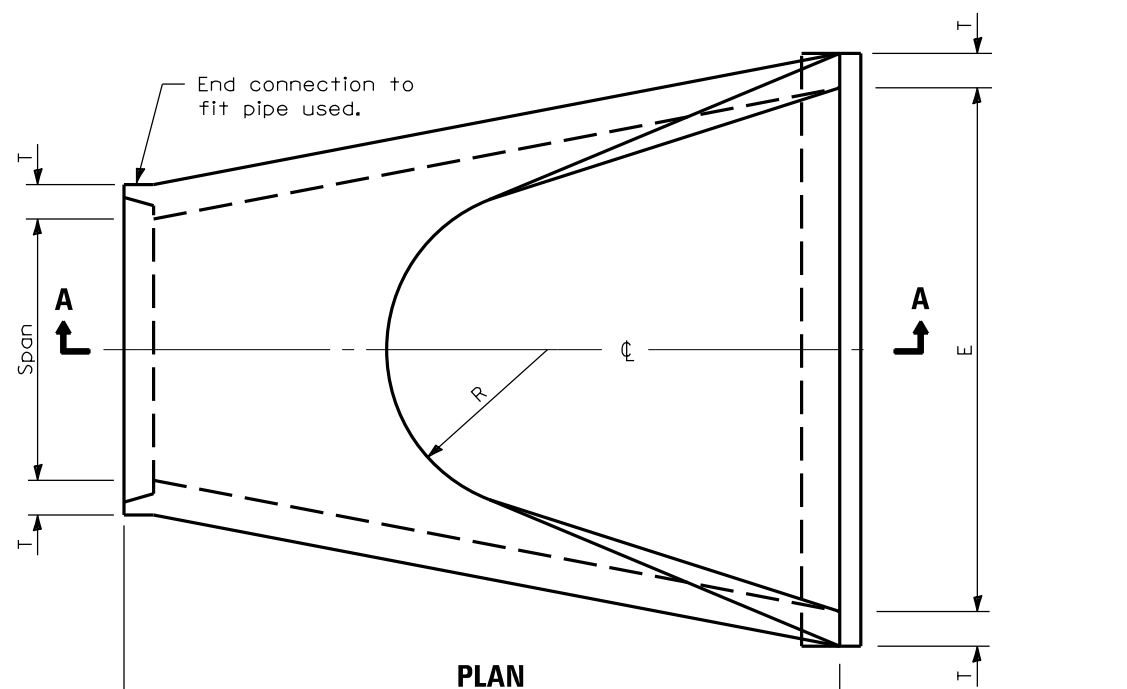

PLAN

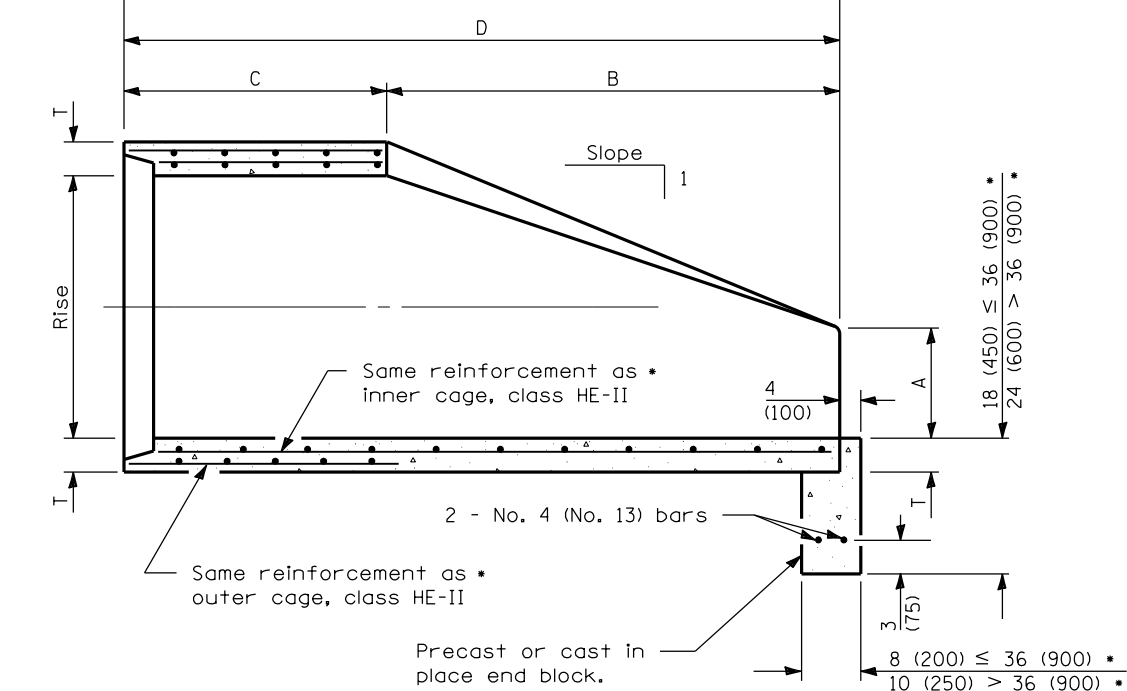

SECTION A-A

• Refers to the equivalent pipe diameter.

SPAN	RISE	EQUIV. DIA.	WALL T	A	B	C	D	E	H	R	R ₁	R ₂	APPROX. SLOPE
23 (584)	14 (356)	18 (450)	2 3/4 (70)	8 (203)	27 (686)	3'-9" (1.143 m)	6'-0" (1.829 m)	36 (914)	5 3/8 (137)	6 (152)	6 (152)	20 (508)	1:3.1
30 (762)	19 (483)	24 (600)	3 1/4 (83)	8 1/2 (216)	39 (991)	33 (838)	6'-0" (1.829 m)	4'-0" (1.219 m)	6 7/8 (175)	7 (178)	8 1/4 (210)	26 1/4 (667)	1:2.8
34 (864)	22 (559)	27 (675)	3 1/2 (89)	9 (229)	4'-0" (1.219 m)	24 (610)	6'-0" (1.829 m)	4'-6" (1.372 m)	7 3/4 (197)	8 (203)	9 1/4 (235)	29 1/4 (743)	1:2.9
38 (965)	24 (610)	30 (750)	3 1/2 (95)	9 1/2 (241)	4'-6" (1.372 m)	18 (475)	6'-0" (1.829 m)	5'-0" (1.524 m)	8 5/8 (219)	9 (229)	10 1/4 (260)	32 3/4 (832)	1:2.9
45 (1143)	29 (737)	36 (900)	4 1/2 (114)	11 1/4 (286)	5'-0" (1.524 m)	36 (914)	8'-0" (2.438 m)	6'-0" (1.829 m)	10 1/2 (267)	12 (305)	12 1/4 (311)	39 1/4 (997)	1:2.7
53 (1346)	34 (864)	42 (1050)	5 (127)	15 3/4 (400)	5'-0" (1.524 m)	36 (914)	8'-0" (2.438 m)	6'-6" (1.981 m)	12 1/8 (308)	13 (330)	14 1/2 (368)	3'-10" (1.168 m)	1:2.6
60 (1524)	38 (965)	48 (1200)	5 1/2 (140)	21 (533)	5'-0" (1.524 m)	36 (914)	8'-0" (2.438 m)	7'-0" (2.134 m)	13 1/2 (343)	14 (356)	16 1/2 (419)	4'-3 1/2" (1.308 m)	1:2.7
68 (1727)	43 (1092)	54 (1350)	6 (152)	26 (660)	5'-0" (1.524 m)	36 (914)	8'-0" (2.438 m)	7'-6" (2.286 m)	15 1/4 (387)	16 (406)	18 3/4 (476)	4'-10 1/2" (1.486 m)	1:2.6
76 (1930)	48 (1219)	60 (1500)	6 1/2 (165)	31 (787)	5'-0" (1.524 m)	36 (914)	8'-0" (2.438 m)	8'-0" (2.439 m)	17 (432)	18 (457)	20 3/4 (527)	5'-5" (1.651 m)	1:2.6

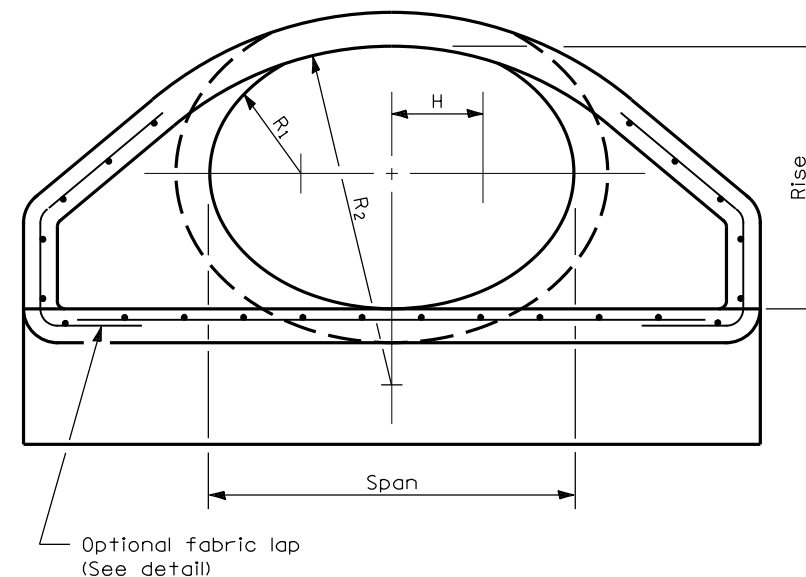

END VIEW

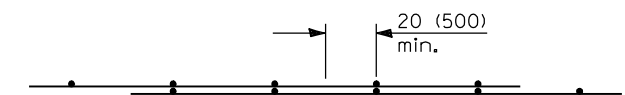

OPTIONAL FABRIC LAP

GENERAL NOTES

All slope ratios are expressed as units of vertical displacement to units of horizontal displacement (V:H).

All dimensions are in inches (millimeters) unless otherwise shown.

DATE	REVISIONS
1-1-09	Switched units to English (metric).
1-1-07	Soft converted metric reinforcement bars.

PRECAST REINFORCED CONCRETE ELLIPTICAL FLARED END SECTION

STANDARD 542306-02

Illinois Department of Transportation

APPROVED January 1, 2009
Ralph E. Anderson
 ENGINEER OF BRIDGES AND STRUCTURES

APPROVED January 1, 2009
Lee E. Han
 ENGINEER OF DESIGN AND ENVIRONMENT

ISSUED 1-1-97

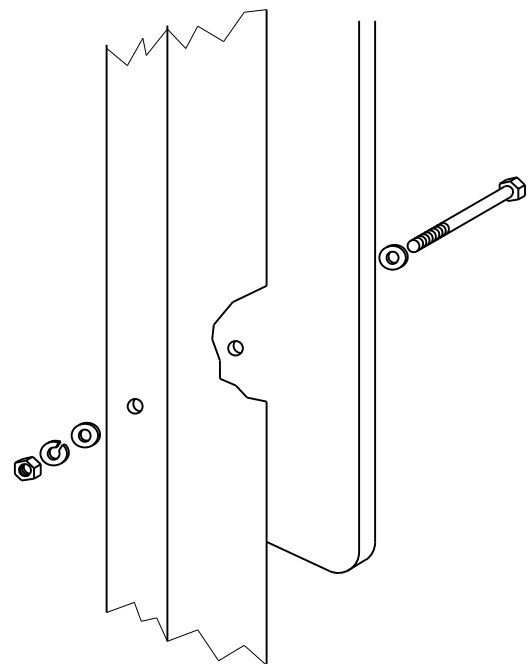

Sign panel 36 (900) wide or less

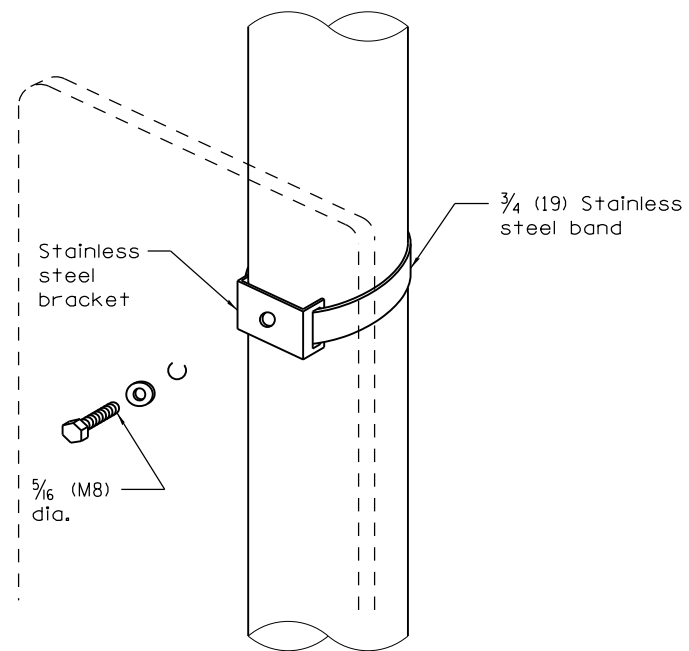

Sign panel 36 (900) wide or less

Section modulus (minimum)	Axis A	Axis B
Steel	0.050 in. ³ (819 mm ³)	0.105 in. ³ (1720 mm ³)
Aluminum	0.150 in. ³ (2458 mm ³)	0.315 in. ³ (5162 mm ³)

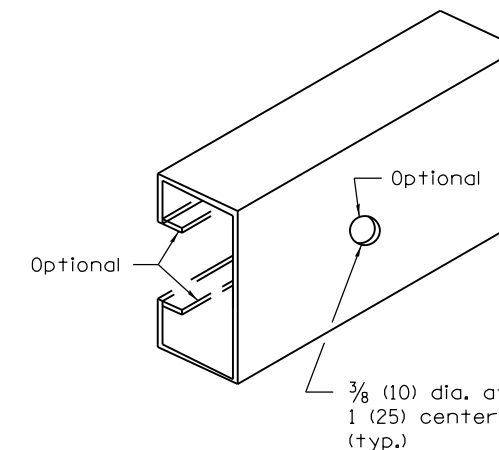
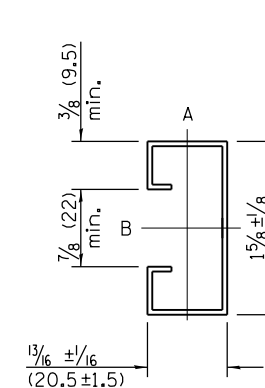

SUPPORTING CHANNEL DETAILS

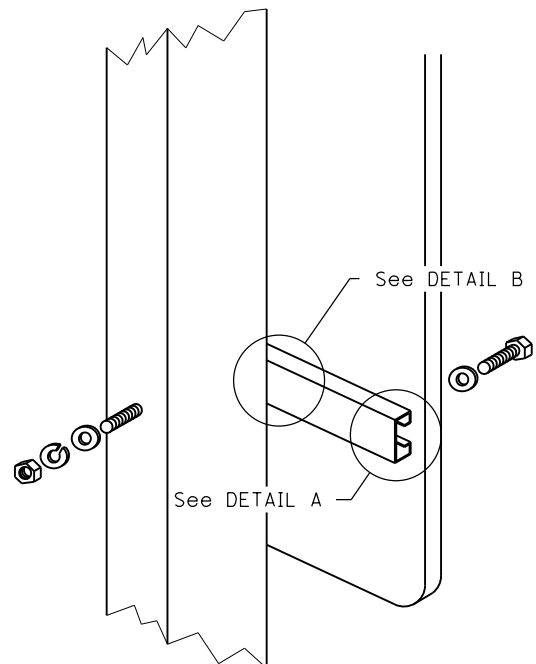

Sign panel over 36 (900) wide

WOOD OR TELESCOPING STEEL POSTS

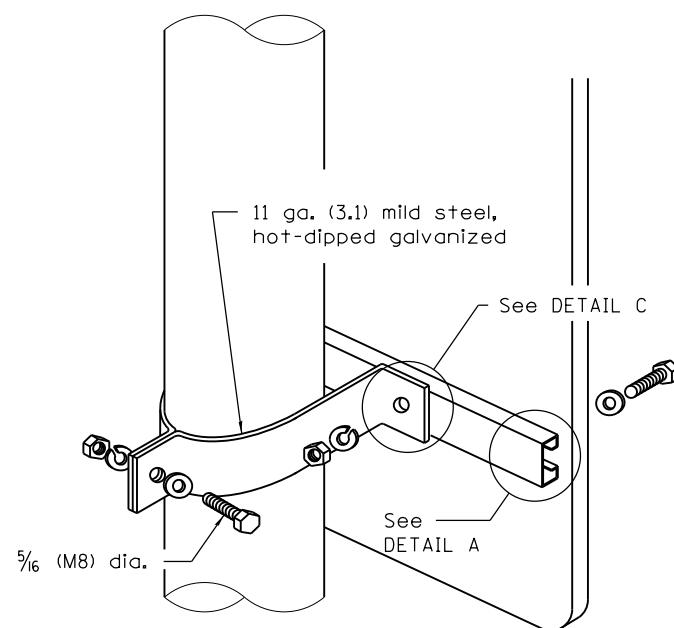

Sign panel over 36 (900) wide

LIGHT OR SIGNAL STANDARDS

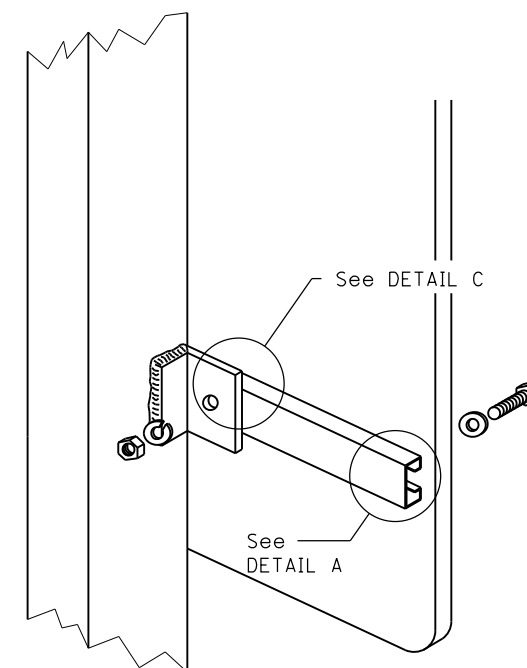

ROUTE MARKER ASSEMBLY

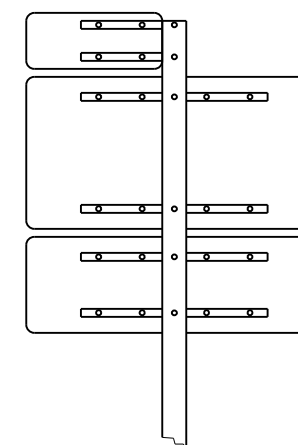

BREAKAWAY STEEL TUBING POSTS

(All sign panel sizes)

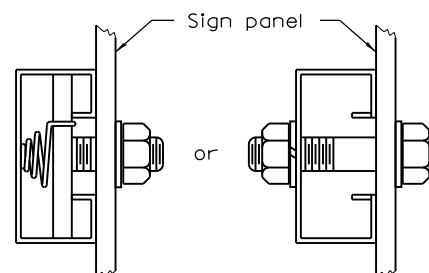

DETAIL A

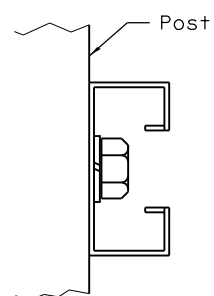

DETAIL B

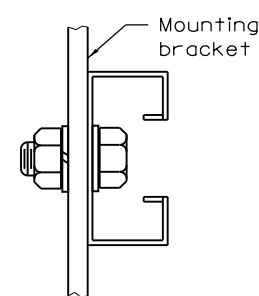

DETAIL C

All dimensions are in inches (millimeters) unless otherwise shown.

DATE	REVISIONS
1-1-09	Switched units to English (metric).
1-1-97	Renum. Standard 2319-6.

SIGN PANEL MOUNTING DETAILS

STANDARD 720001-01

Illinois Department of Transportation

APPROVED January 1, 2009
Joe Hill
 ENGINEER OF OPERATIONS

APPROVED January 1, 2009
Lee E. Han
 ENGINEER OF DESIGN AND ENVIRONMENT

ISSUED 1-1-97

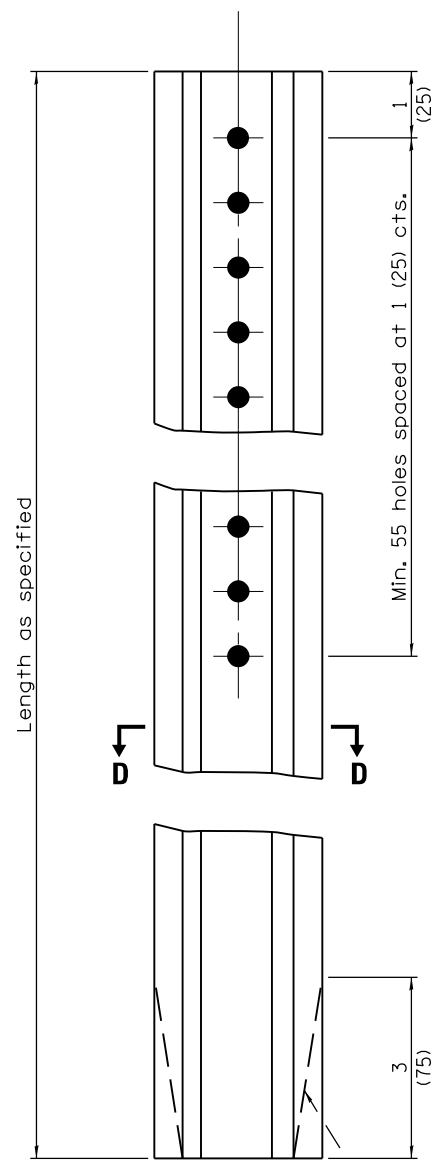

TYPE A

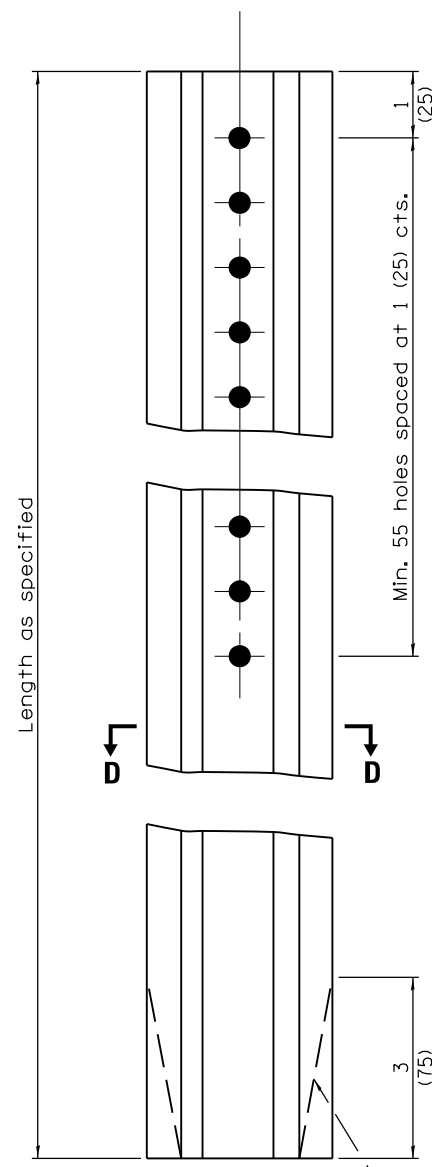
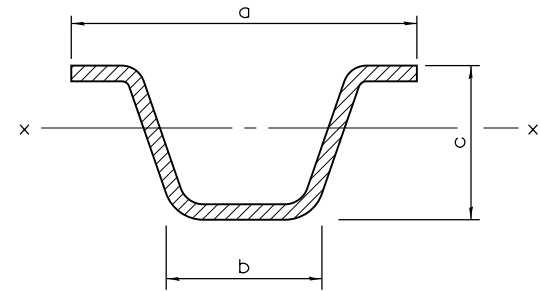

TYPE B

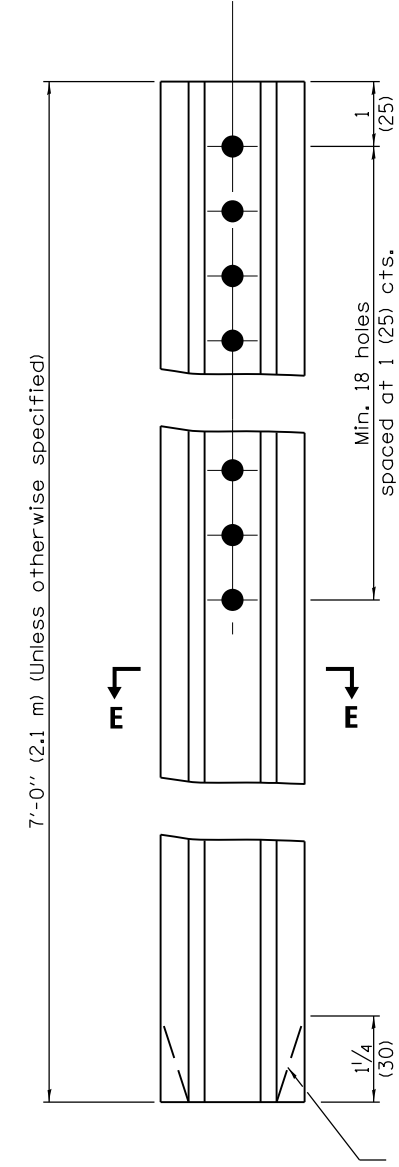

TYPE C

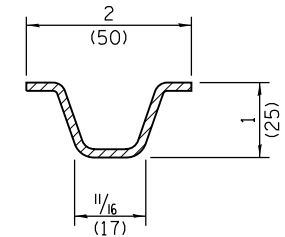

Steel - 1.12 lbs./ft. (1.67 kg/m)

		a	b	c	S _{x-x} in. ³ (mm ³)	lbs./ft. (kg/m)
TYPE A	Steel	3/16 (78)	1/4 (32)	1/8 (37)	0.223 (3,654)	2.00 (2.98)
	Aluminum	3/2 (89)	1 5/8 (41)	1 7/8 (48)	0.435 (7,128)	0.90 (1.34)
TYPE B	Steel	3/8 (81)	1/4 (32)	1/2 (38)	0.341 (5,588)	3.00 (4.46)
	Aluminum	4 5/8 (118)	2 1/4 (57)	2 3/8 (60)	0.888 (14,552)	1.30 (1.93)

GENERAL NOTES

Dimensions shown for cross sections are minimum.

All holes are 3/8 (10).

S_{x-x} is the minimum section modulus about the x-x axis of the post as shown. For posts in which holes are punched or drilled for more than half their length, S_{x-x} shall be computed for the net section.

All dimensions are in inches (millimeters) unless otherwise shown.

Illinois Department of Transportation

PASSED January 1, 2009

ENGINEER OF POLICY AND PROCEDURES

APPROVED January 1, 2009

ENGINEER OF DESIGN AND ENVIRONMENT

ISSUED 1-1-97

DATE	REVISIONS
1-1-09	Switched units to English (metric).
1-1-97	Renum. Standard 2350-4.

METAL POSTS FOR SIGNS, MARKERS & DELINEATORS

STANDARD 720011-01

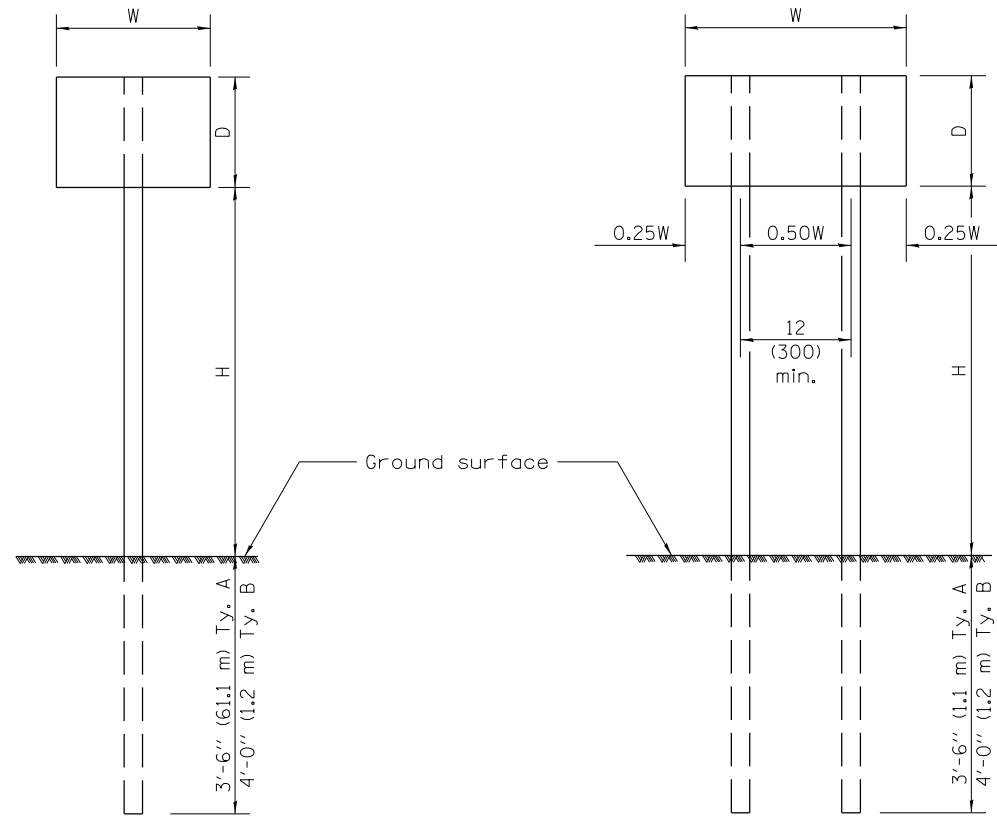

ONE POST INSTALLATION

TWO POST INSTALLATION

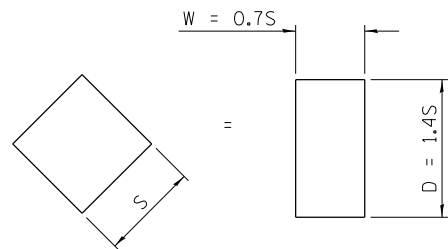

For diamond shaped sign with side S as shown, use required post size for a sign with $W = 0.7S$ and $D = 1.4S$.

SIGN DEPTH (D)	H	NO. AND TYPE OF POST FOR SIGN WIDTH (W)				
		12 (300)	18 (450)	24 (600)	30 (750)	36 (900)
18 (450)	5'-0" (1.5 m)	A	A	A	A	A
	5'-6" (1.7 m)	A	A	A	A	A
	6'-0" (1.8 m)	A	A	A	A	B
	6'-6" (2.0 m)	A	A	A	A	B
	7'-0" (2.1 m)	A	A	A	A	B
	7'-6" (2.3 m)	A	A	A	A	B
	8'-0" (2.4 m)	A	A	A	A	B
	8'-6" (2.6 m)	A	A	A	B	B
	9'-0" (2.7 m)	A	A	A	B	B
24 (600)	5'-0" (1.5 m)	A	A	A	A	B
	5'-6" (1.7 m)	A	A	A	A	B
	6'-0" (1.8 m)	A	A	A	B	B
	6'-6" (2.0 m)	A	A	A	B	B
	7'-0" (2.1 m)	A	A	A	B	B
	7'-6" (2.3 m)	A	A	A	B	B
	8'-0" (2.4 m)	A	A	A	B	2A
	8'-6" (2.6 m)	A	A	B	B	2A
	9'-0" (2.7 m)	A	A	B	B	2A
30 (750)	5'-0" (1.5 m)	A	A	A	B	B
	5'-6" (1.7 m)	A	A	A	B	2A
	6'-0" (1.8 m)	A	A	A	B	2A
	6'-6" (2.0 m)	A	A	A	B	2A
	7'-0" (2.1 m)	A	A	B	B	2A
	7'-6" (2.3 m)	A	A	B	B	2A
	8'-0" (2.4 m)	A	A	B	B	2A
	8'-6" (2.6 m)	A	A	B	2A	2A
	9'-0" (2.7 m)	A	A	B	2A	2A
36 (900)	5'-0" (1.5 m)	A	A	B	B	2A
	5'-6" (1.7 m)	A	A	B	B	2A
	6'-0" (1.8 m)	A	A	B	B	2A
	6'-6" (2.0 m)	A	A	B	2A	2A
	7'-0" (2.1 m)	A	A	B	2A	2A
	7'-6" (2.3 m)	A	A	B	2A	2A
	8'-0" (2.4 m)	A	B	B	2A	2A
	8'-6" (2.6 m)	A	B	B	2A	2B
	9'-0" (2.7 m)	A	B	2A	2A	2B
4'-0" (1.2 m)	5'-0" (1.5 m)	A	A	B	2A	2A
	5'-6" (1.7 m)	A	B	B	2A	2A
	6'-0" (1.8 m)	A	B	B	2A	2A
	6'-6" (2.0 m)	A	B	2A	2A	2B
	7'-0" (2.1 m)	A	B	2A	2A	2B
	7'-6" (2.3 m)	A	B	2A	2B	2B
	8'-0" (2.4 m)	A	B	2A	2B	2B
	8'-6" (2.6 m)	B	B	2B	2B	2B
	9'-0" (2.7 m)	B	2A	2B	2B	2B

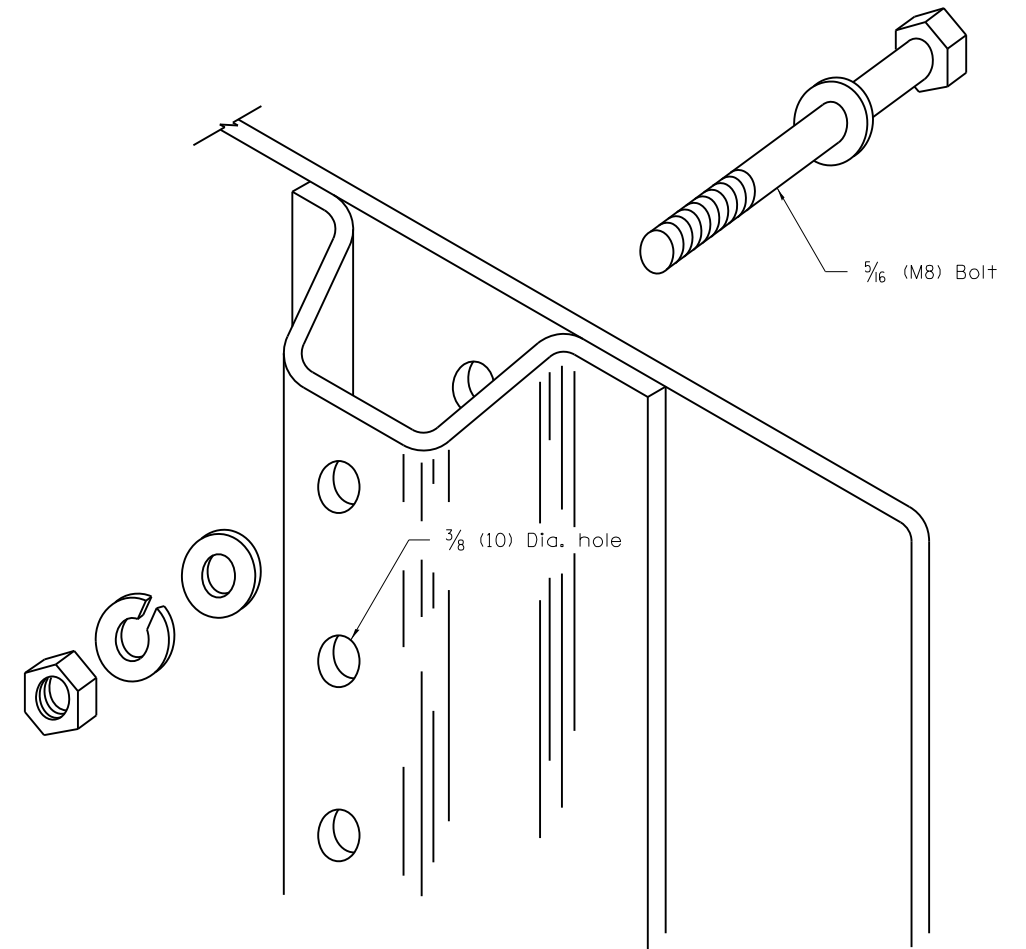

DETAIL OF MOUNTING SIGN TO POST

NOTE: Minimum of 2 bolts per post required.

GENERAL NOTES

DESIGN: Current AASHTO Standard Specifications for Structural Supports for Highway Signs, Luminaires and Traffic Signals.

LOADING: for 60 mph (95 km/h) wind velocity with 30% gust factor, normal to sign.

SOIL PRESSURE: Minimum allowable soil pressure 1.25 tsf (120 kPa).

See Standard 720011 for details of Types A and B posts.

All dimensions are in inches (millimeters) unless otherwise shown.

DATE	REVISIONS
1-1-09	Switched units to English (metric).
1-1-97	Renum. Standard 2363-2.

APPLICATIONS OF TYPES A & B METAL POSTS (FOR SIGNS & MARKERS)

STANDARD 729001-01

Illinois Department of Transportation

PASSED January 1, 2009

ENGINEER OF POLICY AND PROCEDURES

APPROVED January 1, 2009

ENGINEER OF DESIGN AND ENVIRONMENT

ISSUED 1-1-97

BUY AMERICAN REQUIREMENTS



REGIONAL GUIDANCE LETTER—AIRPORTS DIVISION

- NUMBER:** 5100.30
- DATE:** May 9, 2008
- SUBJECT:** Airport Improvement Program (AIP) Buy American Requirement in Construction and Equipment Grants
- REFERENCES:** Title 49 United States Code (USC) (“the Act”), Section 50101
FAA Order 5100.38, “Airport Improvement Program Handbook”
http://www.faa.gov/airports_airtraffic/airports/aip/aip_handbook/

BACKGROUND:

Section 50101 of the Act prohibits the FAA from obligating funds for a grant under the Airport Improvement Program (AIP) unless steel and manufactured goods used in the project are produced in the United States.

This provision was added to the FAA’s authorizing legislation in 1990. The North American Free Trade Agreement (NAFTA) specifically excluded federal grant programs such as AIP. Therefore, NAFTA does not change a Sponsor’s requirement to comply with the Buy American requirement in the Act.

The FAA may waive the requirement if a sponsor submits a written request demonstrating that one of the following criteria applies:

- Applying the provision is not in the public interest. This is reserved for significant public interest determinations;
- The steel or manufactured good is not available in sufficient quantity or satisfactory quality in the United States;
- For AIP grant-funded projects other than ground transportation demonstration projects,
 - the cost of components and subcomponents produced in the United States is more than 60 percent of the cost of all components of the facility or equipment; and
 - final assembly of the facility or equipment has occurred in the United States; or
- Applying this provision would increase the cost of the overall project by more than 25 percent.

As of the date of this Regional Guidance Letter (RGL), a national Program Guidance Letter (PGL) is under development and pending publication. In order to ensure

compliance for grants issued prior to the PGL's final publication, this RGL is intended to provide interim guidance for all AIP-funded construction and equipment grants.

INTERIM REGIONAL POLICY AND PROCEDURES:

All sponsors are reminded that the "Terms and Conditions of Accepting Airport Improvement Program Grants" (dated June 2005) includes a certification in Section II (General Conditions), Subsection J stating that:

Unless otherwise approved by the FAA, it will not acquire or permit any contractor or subcontractor to acquire any steel or manufactured products produced outside the United States to be used for any project for airport development or noise compatibility for which funds are provided under this grant. The sponsor will include in every contract a provision implementing this condition.

As with all required terms and conditions, sponsors are responsible for ensuring that their certifications are complete and accurate. Sponsors are therefore also responsible for determining if they may require a waiver for a particular project. Until the PGL is finalized and published, it shall be the policy of the Great Lakes Region that any sponsor asking the FAA to waive this requirement must do so in writing (see Exhibit A).

Neither the Region nor ADOs are authorized to approve waivers under the first or second criteria above. If the ADO recommends a waiver pursuant to the first or second criteria, they shall forward the request with their recommendation to AGL-610, who will in turn review and relay such requests to APP-500 for adjudication. Sponsors are urged to submit such requests as early as possible, generally providing at least 30 calendar days prior to anticipated grant award.

ADOs and block-grant states are hereby authorized to approve written waiver requests under the third or fourth criteria above. Consistent with other sponsor certifications, the FAA may base its approval entirely on the information provided by the sponsor, without any obligation to conduct independent review, research or verification of the information presented.

The original written request, all supporting documentation and the final waiver must be retained in the grant documentation file or binder.

FAA CERTIFIED EQUIPMENT:

All ADOs, sponsors, consultants and contractors are advised and reminded that FAA certification of equipment for a particular purpose does not necessarily mean that the equipment satisfies the Buy American requirement. The FAA certifies equipment for technical and functional specifications, without regard to how the equipment is funded. When equipment is funded with AIP grants, a number of additional legal and administrative requirements apply, including the Buy American provision.



Jeri Alles
Airports Division Manager
Great Lakes Region

Exhibit A (Request for Waiver of Buy American Requirement)

Airport Sponsor [insert legal name of sponsor]

Official Representative [insert name]

Project Name [insert]

Indicate reason(s) for waiver request. Supporting documentation must be provided for each reason indicated.

- A. Applying the provision is not in the public interest. This is reserved for significant public interest determinations.
- B. The steel or manufactured good is not available in sufficient quantity or satisfactory quality in the United States.
- C. For AIP grant-funded projects other than ground transportation demonstration projects:
 - the cost of components and subcomponents produced in the United States is more than 60 percent of the cost of all components of the facility or equipment; and
 - final assembly of the facility or equipment has occurred in the United States.
- D. Applying this provision would increase the cost of the overall project by more than 25 percent.

Signature

I hereby request a waiver of the Buy American requirements for the reason(s) indicated above. All documentation provided in support of this request is true and complete to the best of my knowledge.

Date

FAA USE ONLY BELOW THIS LINE

Waiver requests based on Criteria A or B above require approval by Headquarters

ADO Recommendation Recommended Not recommended

ADO Manager [insert name]

Signature

Date [insert]

RO Recommendation Recommended Not recommended

610 Branch Manager [insert name]

Signature

Date [insert]

ADO Manager or block-grant state may approve waivers based on Criteria C or D above

Waiver Determination Approved Denied Further information required

ADO Manager [insert]

Signature

Date [insert]



U.S. Department
of Transportation

**Federal Aviation
Administration**

Memorandum

Subject: **ACTION:** Program Guidance Letter 10-02

Date: February 24, 2010

From: Manager, Airports Financial Assistance Division,
APP-500

Reply to: Nancy S. Williams
Attn. of: 202-267-8822

To: PGL Distribution List

We are issuing this Program Guidance Letter on Buy American requirements.

A handwritten signature in blue ink, appearing to read "Frank J. San Martin".

Frank J. San Martin

Guidance for Buy American on Airport Improvement Program (AIP) or American Recovery and Reinvestment Act (ARRA) projects.

In accepting AIP or ARRA funding, grant recipients are certifying that they will not acquire (or permit any contractor or subcontractor) to use any steel or manufactured products produced outside the United States on any portion of the project for which funds are provided, unless otherwise approved by the FAA. Therefore, for the AIP or ARRA funded portion of a project, grant recipients must either:

1. Certify, in writing, all products are wholly produced in the US of US materials, or
2. Request a waiver to use non-US produced products, or
3. Certify that all equipment that is being used on the project is on the Nationwide Buy American conformance list.

The AIP funded portion of a project includes the grant recipient's local share.

Types of Waivers

There are four types of waivers to Buy American:

1. Public interest waiver;
2. Insufficient quantity AND quality for ARRA (AIP projects allow waivers for insufficient quantity OR quality);
3. 60% or more of the components and subcomponents in the facility or equipment are of US origin and final assembly is in the US; or
4. Applying Buy American increases the cost of the overall project by more than 25%.

Many pieces of equipment are constructed with some non-US produced components or subcomponents. Therefore, it is expected that the majority of grants will have waivers issued unless the project is constructed of materials that already have a nationwide waiver.

Nationwide Waiver

Much of the equipment that is frequently used on AIP or ARRA projects has been reviewed by FAA Headquarters and a nationwide waiver has been issued. The Nationwide Buy American conformance list is posted on the www.faa.gov website at the following address:

http://www.faa.gov/airports/aip/procurement/federal_contract_provisions/
by clicking the tab, "Equipment Meeting Buy American Requirements"

If the equipment is on the nationwide waiver list, no additional waiver is required.

Who can Issue Waivers

Only FAA headquarters may issue waivers for reasons 1 and 2. FAA field offices (Regional Offices and/or Airports District Offices) may issue waivers for reasons 3 and 4.

For block grant state projects, the FAA must issue the waivers. Block grant states are not allowed to issue a waiver.

Defining the Project, Facility and Equipment, and Final Assembly Location in the 60%/US final assembly waiver

The waiver can be considered if “at least 60% of the cost of the components and subcomponents in the **facility or equipment** are produced in the United States and the final assembly of the facility or equipment has occurred in the United States.” The correct application of the terms is discussed below.

Project

The “**Project**” is generally the project that is being bid. The “Project” does not extend over multiple grants or phases, even though the overall project may be phased or may be built in multiple bid packages.

Facility or Equipment

- For a building, the portion of the building that is being funded under the AIP or ARRA grant is the “**facility**” listed in the waiver.
- For other projects, the bid items as described in the latest edition of FAA Advisory Circular 5370-10 will generally be the “**equipment**” referred to in the waiver except for airfield electrical equipment.
- For airfield electrical equipment, the “L-” items listed in the Addendum to FAA Advisory Circular 5345-53C, latest edition will generally be the “**equipment**” referred to in the waiver.
- For a vehicle or single piece of equipment like a snow plow or ARFF vehicle, the single vehicle itself is the “**equipment.**”

Final Assembly Location and Labor Exclusion

Final assembly is the substantial transformation of the various components and subcomponents into the equipment. For a building, the final assembly is actual construction of the building.

- For any project other than a building project, the final assembly location is the location where the equipment is assembled, **not the project site itself.**
- For a building, the final assembly location is the airport building site.

In any calculation of Buy American percentage, the labor for the final assembly is excluded. This is because the Buy American statute is based on the cost of materials and equipment, not labor. For a building, this means that only the costs of the materials as they are delivered to the airport site are considered when calculating US and non-US component and subcomponent costs. For equipment, the costs of the final assembly at the manufacturing site are excluded.

Common Materials that are waived or excluded from Buy American - Cement, Concrete, Asphalt and Steel

Cement and concrete is excluded from the Buy American preference requirements (although the steel used for reinforcement, ties, stirrups, etc. must meet Buy American.)

Asphalt and other petroleum products are waived as an excepted item under AMS Guidance T3.6.4.1.e: Foreign Acquisition – Definitions identifying Asphalt as a petroleum product.

Steel is specifically identified in the statute. Therefore, all rebar and discrete, identifiable steel components must be manufactured in the United States.

FAA Waiver

After the FAA has determined that the final assembly location is in the US and the percent of US components and subcomponents is above 60%, a waiver may be issued. **The waiver is for the single project – not a nationwide waiver.**

What Information is required to Issue a Waiver (AIP and ARRA) and for the Federal Register Notice (ARRA)

For waiver type 3, a waiver can be considered if “at least 60% of the cost of the components and subcomponents in the **facility or equipment** are produced in the United States and the final assembly of the facility or equipment has occurred in the United States.”

Grant recipients must request waivers from FAA in writing, with sufficient supporting information. Grant recipients are responsible for ensuring their waiver request is complete and accurate using project specific information provided directly by the contractor or the contractor’s supplier.

The FAA will conduct its review and approval based on the information provided by the grant recipient.

The information that must be provided for either equipment or for a building:

- Project Number
- Project Name
- Airport Name
- Total Project Cost
- Total Equipment or Bid Item Cost for which the waiver is being requested
- Total Equipment or Bid Item Cost excluding labor for final assembly.

For equipment, the following additional information is required:

- The equipment or bid item for which the waiver is being requested
- The manufacturer and country of origin of the equipment or bid item.
- The location of the final assembly of the equipment or bid item (not the airport site)

- The cost of the US components and subcomponents for the equipment or bid item for which the waiver is being requested
- The cost of the non-US components and subcomponents for the equipment or bid item for which the waiver is being requested
- The resulting percent of US and non-US components

For a building, the following additional information is required:

- The building (called the facility in the Buy American statute) for which the waiver is being requested
- The manufacturer and country of origin of the US and non-US materials that will be used in the building,
- For a building, the location of the final assembly is the airport site
- The cost of the US components and subcomponents for the equipment or bid item for which the waiver is being requested
- The cost of the non-US components and subcomponents for the equipment or bid item for which the waiver is being requested
- The resulting percent of US and non-US components

Grant recipients are urged to submit waiver requests as early as possible.

Waivers that are issued on ARRA projects must be included in a Federal Register notice, which will generally be published on a quarterly basis.

Sample Letter of Approval of Waiver:

When FAA is satisfied that a waiver may be issued based on the 60%/US final assembly criteria, a letter must be written to the airport sponsor approving the waiver. The text of the letter follows.

A copy of the letter must be forwarded to APP-500 along with a copy of the supporting documentation that was submitted by the airport for the waiver. The information used in the letter will be the basis of the Federal Register notice. The Federal Register notice may include copies of the waiver letters or will be a tabular listing of the waivers. Therefore, regions must forward both a *.pdf copy of the signed letter and an editable copy of the letter.

XXXX Airport
 AIP-Project No. X-XX-XXXX-XX
 Project Name
 Waiver of Buy American Requirements

I have reviewed the request for Waiver of Buy American Requirement submitted XXX for the use of XXXXX equipment on the subject project. The information submitted by the airport for:

Item for which waiver is being issued: i.e L-831 Transformers
 Manufacturer:
 Final Assembly Location:

Percent US Components and Subcomponents:

The information submitted satisfies the requirement for waiver of the requirements of the Buy American per 49 USC Section 50101 based on over 60% of the cost of components and subcomponents to be used in the project being produced in the United States.

The waiver is hereby approved for use on this AIP grant project.

Common Misconceptions

- Belief that if a manufacturer is "FAA-certified" that Buy America has been satisfied. This is not true. The FAA certification certifies that technical standards have been met. However, FAA-certified equipment manufactured outside the U.S. does not meet Buy America provisions of the AIP unless a waiver has been issued.
- Misconception that the North America Free Trade Act (NAFTA) exempts equipment manufactured in Mexico or Canada from "Buy America" requirements. This is not true for AIP or ARRA projects.

Text of Buy American statute from 49 United States Code §50101

§ 50101. Buying goods produced in the United States

(a) **Preference.**— The Secretary of Transportation may obligate an amount that may be appropriated to carry out section [106 \(k\)](#), [44502 \(a\)\(2\)](#), or [44509](#), subchapter I of chapter 471 (except section [47127](#)), or chapter 481 (except sections [48102 \(e\)](#), [48106](#), [48107](#), and [48110](#)) of this title for a project only if steel and manufactured goods used in the project are produced in the United States.

(b) **Waiver.**— The Secretary may waive subsection (a) of this section if the Secretary finds that—

- (1) applying subsection (a) would be inconsistent with the public interest;
- (2) the steel and goods produced in the United States are not produced in a sufficient and reasonably available amount or are not of a satisfactory quality;
- (3) when procuring a facility or equipment under section [44502 \(a\)\(2\)](#) or [44509](#), subchapter I of chapter 471 (except section [47127](#)), or chapter 481 (except sections [48102 \(e\)](#), [48106](#), [48107](#), and [48110](#)) of this title—

(A) the cost of components and subcomponents produced in the United States is more than 60 percent of the cost of all components of the facility or equipment; and

(B) final assembly of the facility or equipment has occurred in the United States; or

(4) including domestic material will increase the cost of the overall project by more than 25 percent.

(c) **Labor Costs.**— In this section, labor costs involved in final assembly are not included in calculating the cost of components.