

DETAIL--"D"

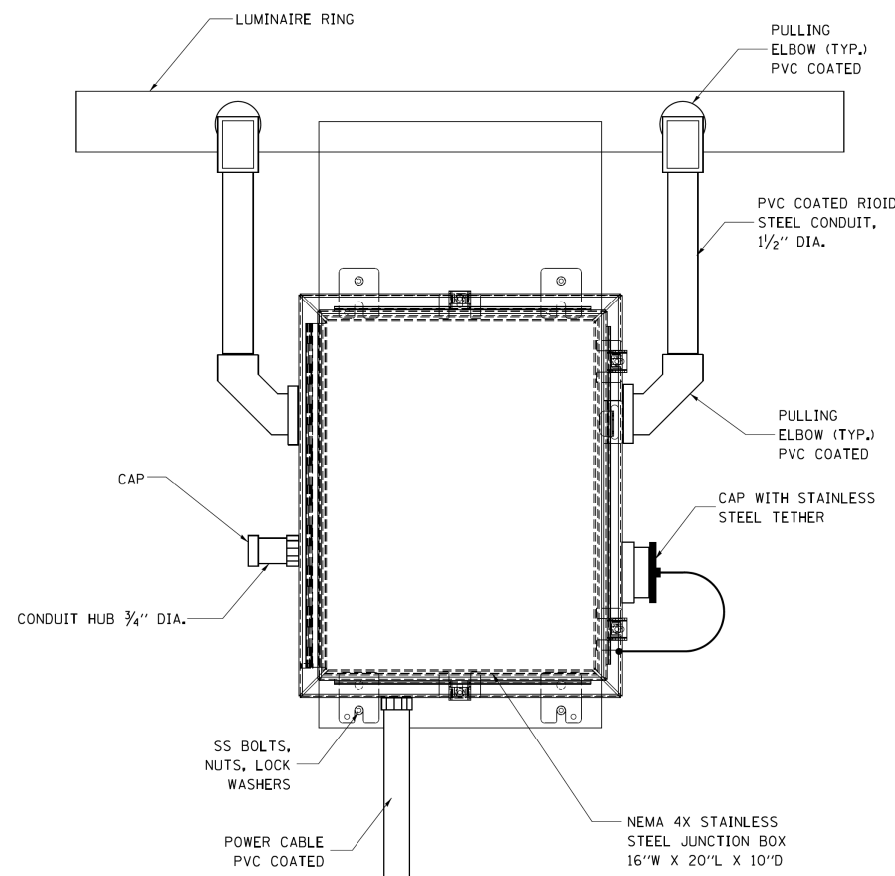

FRONT VIEW
N.T.S.

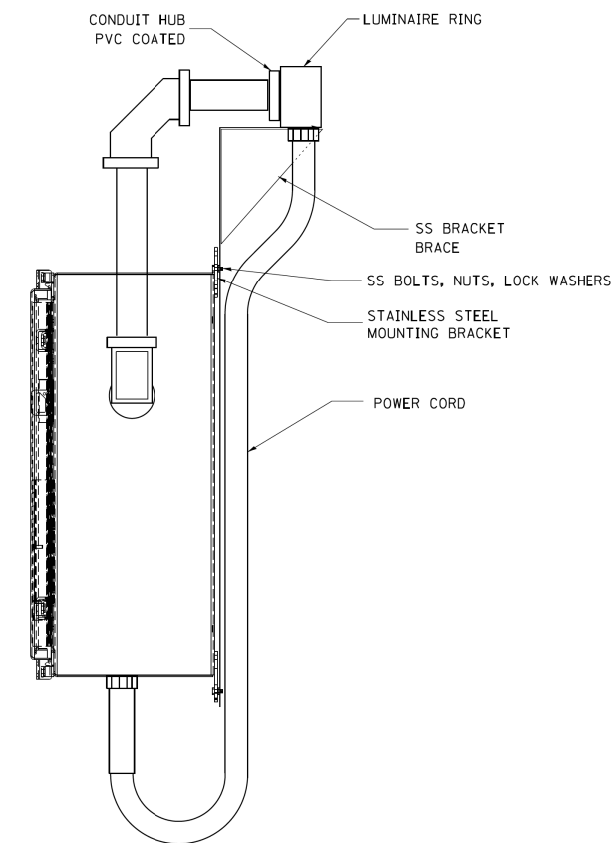

SIDE VIEW
N.T.S.

LUMINAIRE RING TERMINAL BOX

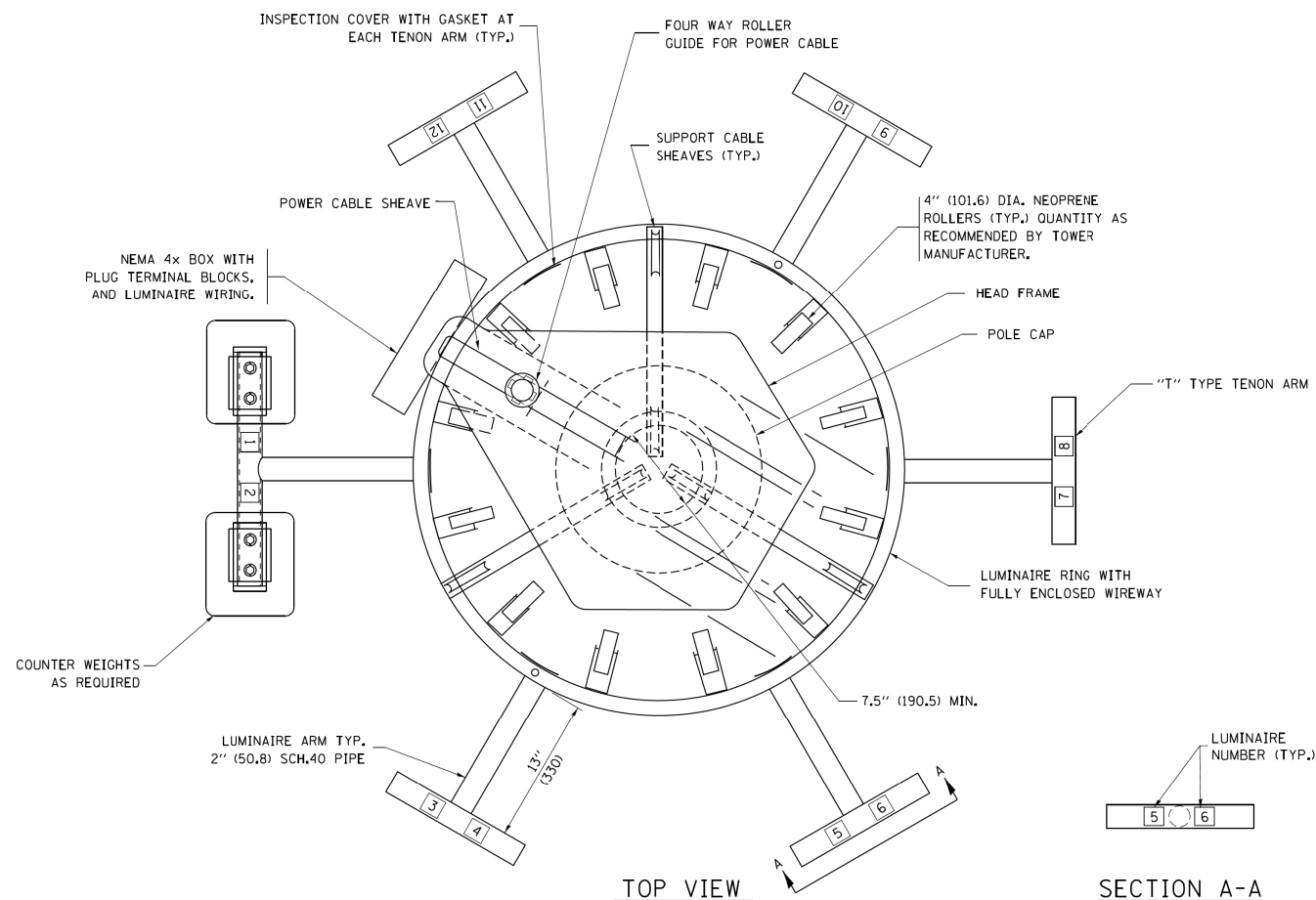

TOP VIEW

SECTION A-A

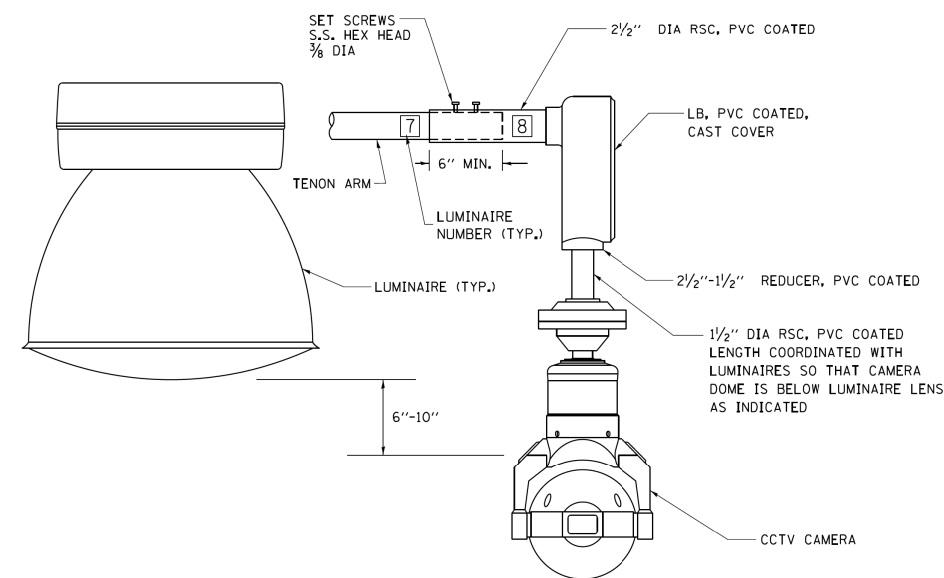

CCTV CAMERA MOUNTING DETAIL

NOTES:

- LUMINAIRE WIRES SHALL EXTEND 24 INCHES (609 mm) LONGER THAN THEIR RESPECTIVE TENON ARM AND SHALL BE TRAINED BACK INTO THE ARM WHICH SHALL THEN BE CLOSED WITH A CAP AS SPECIFIED. ALL WIRES SHALL BE CAPPED WITH HEAT SHRINK INSULATING BOOTS, CRIMP CAPS ARE UNACCEPTABLE. ALL RING WIRES SHALL BE TAGGED WITH WIRE MARKERS AT BOTH ENDS. THE TENON ARMS SHALL ALSO BE TAGGED CORRESPONDING TO THE WIRING CONTAINED WITHIN.
- SPLICING WILL NOT BE ALLOWED WITHIN THE LUMINAIRE RING.
- ALL TOWER SHAFT HARDWARE, SUCH AS GROUND LUGS, JUNCTION BOXES, HARDWARE FOR THE HANDHOLE DOOR, INCLUDING THE HANDLE/LATCH MECHANISM, HINGE AND DOOR STOP, SHALL BE STAINLESS STEEL. ALL CONDUIT AND CONDUIT FITTINGS SHALL BE PVC COATED GALVANIZED STEEL.
- ALL MULTI-CONDUCTOR CABLES SHALL BE FITTED WITH A HEAT-SHRINK MULTI-LEG BOOT. THE BOOT SHALL MEET MILITARY SPECIFICATION MIL-I-81765/1.

FILE PATH = CA\Project\14-0323 - W28 Final PDFs\0160W28-SHT-D1-Detail-(BE-505B).dgn



D160W28-SHT-D1-Detail-(BE-505B).dgn
 USER NAME = ayeung
 PLOT SCALE = 50.0000' / in.
 PLOT DATE = 3/24/2014

DESIGNED - 09-02-03
 DRAWN - 03-22-10
 CHECKED - 09-02-10
 DATE - 02-27-13

STATE OF ILLINOIS
 DEPARTMENT OF TRANSPORTATION

HIGH MAST LIGHT TOWER
 120 FT TO 140 FT (36 m TO 43 m)

SCALE: SHEET 9 OF 40 SHEETS STA. TO STA.

F.A.I. RTE. 90/94/290	SECTION 2013-010R	COUNTY COOK	TOTAL SHEETS 747	SHEET NO. 593
BE-505b		CONTRACT NO. 60W28		
ILLINOIS FED. AID PROJECT				