

**GENERAL NOTES:**

1. Wall repair locations are approximate and were determined from field inspection performed at the time of plan preparation. The necessary adjustments based on current field conditions will be made at time of construction. Such variations shall not be cause for additional compensation for a change in the scope of work. However, the Contractor will be paid for the actual quantity furnished at the unit price bid for the work.
2. Stations and offsets of Existing Retaining Wall 2 are referenced along proposed Ramp NW Baseline.
3. Plan dimensions and details relative to existing plans are subject to nominal construction variations. The Contractor shall field verify existing dimensions and details affecting new construction and make necessary approved adjustments prior to construction or ordering of materials. Such variations shall not be cause for additional compensation for a change in scope of the work, however, the Contractor will be paid for the quantity actually furnished at the unit price bid for the work.
4. Existing reinforcing steel which is exposed by the concrete repair process, but is to remain embedded in the existing structure and reused, shall be cleaned to be free of existing concrete and rust, and straightened if necessary. Existing reinforcing steel which is cut, stretched or damaged by the Contractor during the concrete repair process shall be replaced by embedded reinforcing steel or anchorage, equal to or greater than the size of original reinforcing steel, at no cost to the Department. See Special Provisions for Structural repair of concrete.

**TOTAL BILL OF MATERIALS**

DESCRIPTION	UNIT	TOTAL
STRUCTURAL REPAIR OF CONCRETE (DEPTH EQUAL TO OR LESS THAN 5 IN.)	SQ. FT.	25
STRUCTURAL REPAIR OF CONCRETE (DEPTH GREATER THAN 5 IN.)	SQ. FT.	11
EPOXY CRACK INJECTION	FOOT	92
FENCE REMOVAL	FOOT	1,601
CONCRETE REMOVAL	CU.YD.	1
CHAIN LINK FENCE, 42" ATTACHED TO STRUCTURE (SPECIAL)	FOOT	1,601

**INDEX OF SHEETS**

- RW2-01 General Plan
- RW2-02 Total Bill of Material, Index of Sheets & General Notes
- RW2-03 Front of Wall Elevations - I
- RW2-04 Front of Wall Elevations - II
- RW2-05 Front of Wall Elevations - III
- RW2-06 Back of Wall Elevations - I
- RW2-07 Back of Wall Elevations - II
- RW2-08 Back of Wall Elevations - III
- RW2-09 Fence Details

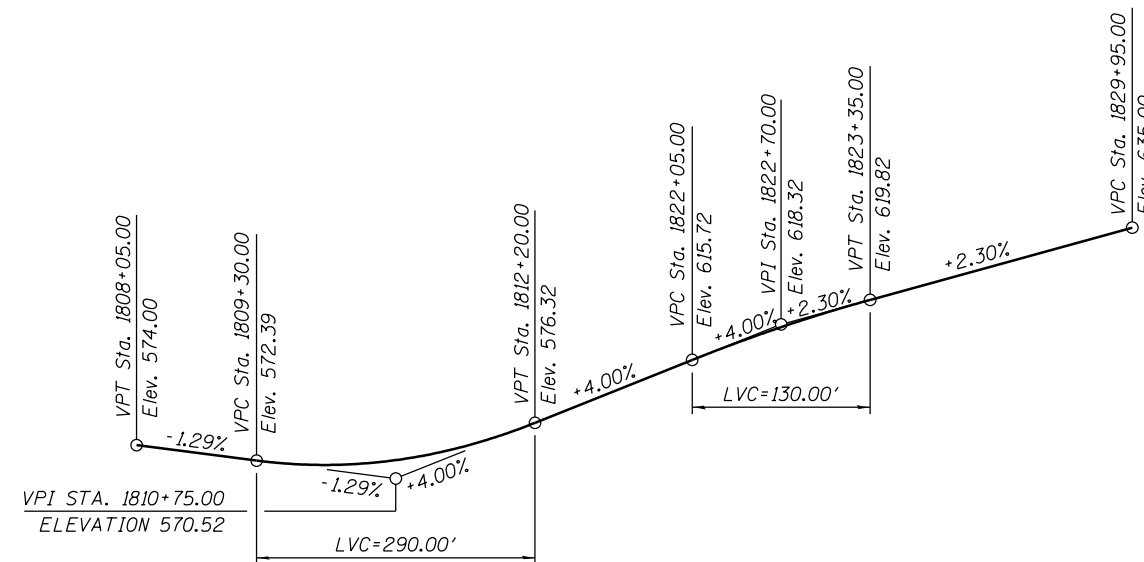

**PROFILE GRADE**  
(along Ramp NW)

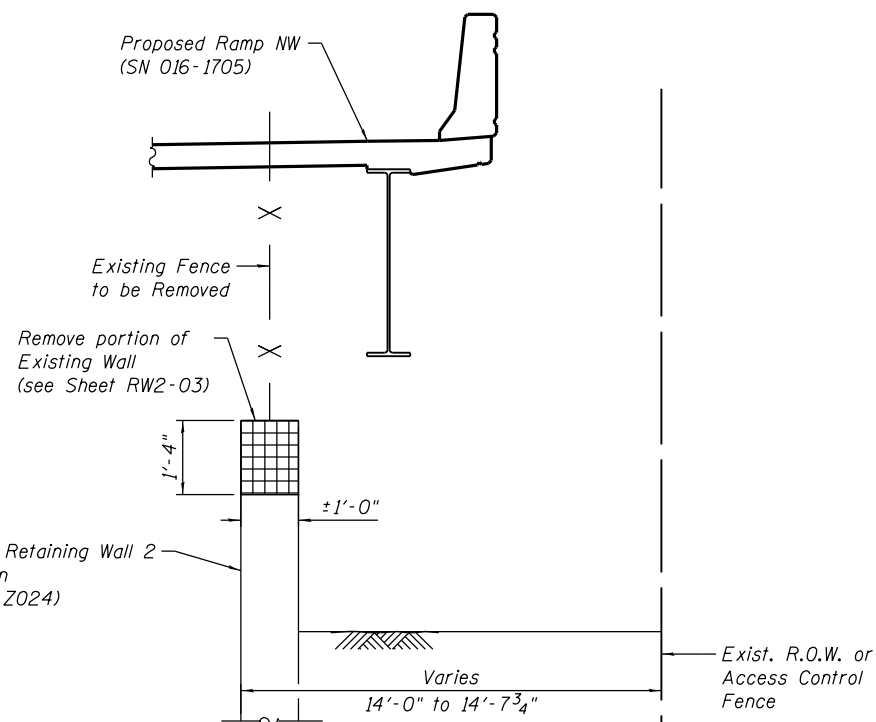

**SECTION A-A**  
(From Sta. 1818+45.67 to 1820+36.40)

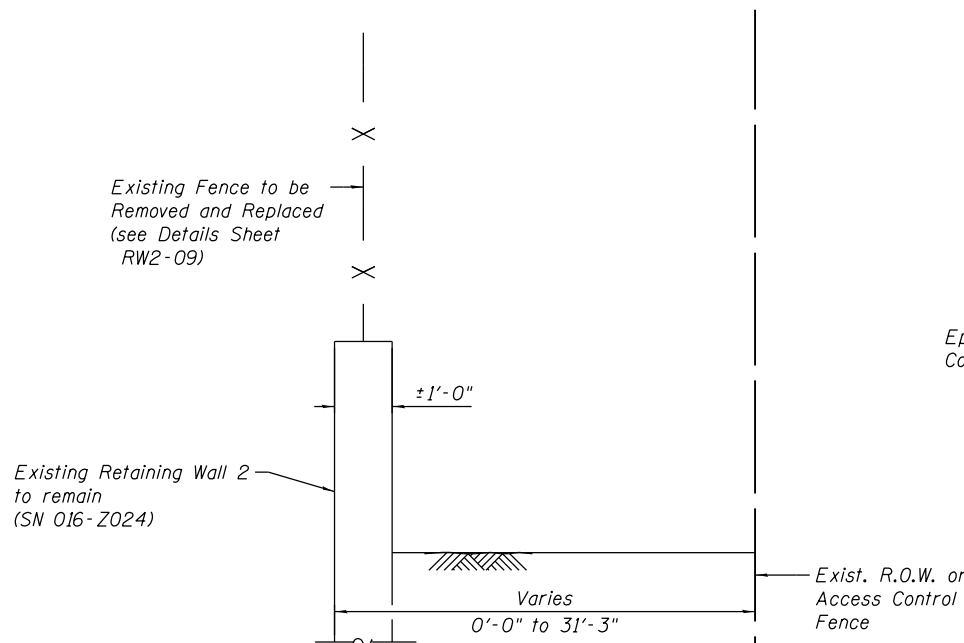

**SECTION B-B**  
(From Sta. 1808+66.41 to 1818+45.67  
Sta. 1820+36.40 to 1824+66.01)

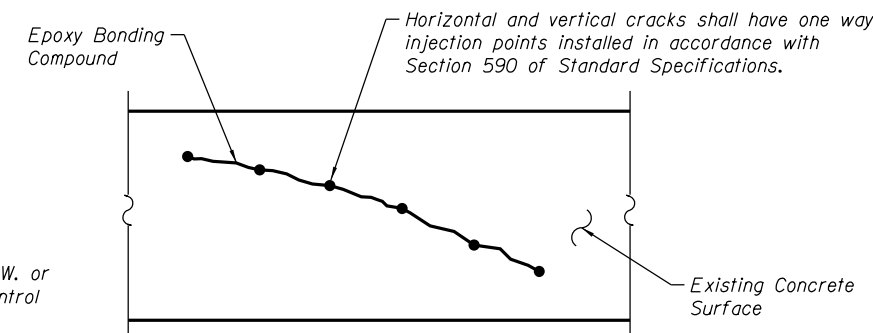

**EPOXY CRACK INJECTION**

016Z024-60W28-RW2-2.dgn



USER NAME = kritzm	DESIGNED - ATB	REVISED
	CHECKED - EJO	REVISED
PLOT SCALE = N.T.S.	DRAWN - MRK	REVISED
PLOT DATE = 4/28/2014	CHECKED - ATB	REVISED

**STATE OF ILLINOIS  
DEPARTMENT OF TRANSPORTATION**

**TOTAL BILL OF MATERIAL, INDEX OF SHEETS & GENERAL NOTES  
STRUCTURE NO. 016-Z024**

SHEET NO. RW2-02 OF RW2-09 SHEETS

F.A.I. RTE. 90/94/290	SECTION 2013-010R	COUNTY COOK	TOTAL SHEETS 747	SHEET NO. 534
CONTRACT NO. 60W28			ILLINOIS FED. AID PROJECT	