

TEMPORARY PAVEMENT DETAILS:

DETAIL A: FULL DEPTH TEMPORARY HMA PAVEMENT

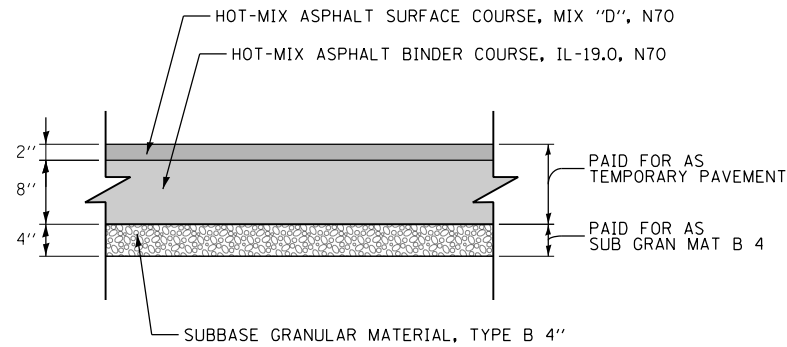

**TEMPORARY HMA PAVEMENT FOR
TEMPORARY RAMP NW, TEMPORARY RAMP
SW, AND TAYLOR ENTRANCE RAMP**

DETAIL B: TEMPORARY PCC PAVEMENT

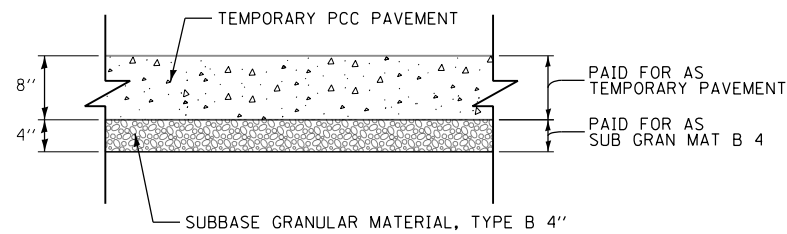

**TEMPORARY PCC PAVEMENT FOR
TEMPORARY RAMP NW, TEMPORARY RAMP
SW, AND TAYLOR ENTRANCE RAMP**

TEMPORARY PAVEMENT GENERAL NOTES:

1. THE CONTRACTOR SHALL HAVE THE OPTION OF USING HMA OR PCC SECTION FOR TEMPORARY PAVEMENT.
2. TEMPORARY HMA TEMPORARY PAVEMENT SHALL CONSIST OF TWO ITEMS: HMA BINDER COURSE AND HMA SURFACE COURSE.
3. PORTLAND CEMENT CONCRETE TEMPORARY PAVEMENT SHALL CONSIST OF CLASS PV CONCRETE MEETING THE REQUIREMENTS OF ARTICLE 1020 OF THE STANDARD SPECIFICATIONS. TEMPORARY PCC PAVEMENT DOES NOT REQUIRE DOWEL BARS.
4. QUALITY MANAGEMENT PROGRAM (QMP) IDENTIFIES THE PARTICULAR QUALITY CONTROL SPECIFICATION THAT APPLIES TO THE HMA MIXTURE.

HOT MIX ASPHALT MIXTURE REQUIREMENTS

MIXTURE TYPE	AIR VOIDS (%) @ NDES	OMP
TEMPORARY PAVEMENT (IF HMA OPTION IS SELECTED BY CONTRACTOR) TEMPORARY RAMP NW AND TEMPORARY RAMP SW		
HOT-MIX ASPHALT SURFACE COURSE, MIX "D", N70, (IL-9.5 MM): 2"	4% @ 70 GYR	QC/QA
HOT-MIX ASPHALT BINDER COURSE, IL-19.0, N70: 8" (IN 3 LIFTS)	4% @ 70 GYR	QC/QA
WB I-290		
POLYMERIZED HOT-MIX ASPHALT SURFACE COURSE, MIX "F", N90, (IL-9.5 MM): 1 3/4"	4% @ 90 GYR	QC/QA
HOT-MIX ASPHALT BINDER COURSE, IL-19.0, N70: 2 1/4"	4% @ 70 GYR	QC/QA
RAMP NW, TAYLOR ENTRANCE RAMP, WB I-290, AND RAMP SW (INTERIM)		
STABILIZED SUBBASE - HOT-MIX ASPHALT, 4" (HMA BINDER IL-19 MM)	3% @ 50 GYR	QCP
OMP DESIGNATION: QUALITY CONTROL/QUALITY ASSURANCE (QC/QA); QUALITY CONTROL FOR PERFORMANCE (QCP)		

1. THE UNIT WEIGHT USED TO CALCULATE ALL HMA SURFACE MIXTURE QUANTITIES IS 112 LBS/SQ YD/IN.
2. THE AC TYPE FOR POLYMERIZED HMA MIXTURES SHALL BE "SBS/SBR PG 76-22" AND FOR NON-POLYMERIZED HMA THE "AC TYPE" SHALL BE "PG 64-22" UNLESS MODIFIED BY DISTRICT ONE SPECIAL PROVISIONS. FOR USE OF RECYCLED MATERIALS SEE DISTRICT ONE SPECIAL PROVISIONS.

FILE PATH = C:\Users\alizabeth\OneDrive\Desktop\Fprints\Final Sheets\0160W28-sht-Typical-10.dgn



0160W28-sht-Typical-10.dgn
USER NAME = alizabeth
PLOT SCALE = 20.0000' / in.
PLOT DATE = 4/27/2014

DESIGNED - OPS
DRAWN - NSA
CHECKED - KCF
DATE - 04/28/14

REVISED -
REVISED -
REVISED -
REVISED -

STATE OF ILLINOIS
DEPARTMENT OF TRANSPORTATION

TYPICAL SECTIONS

SCALE: NONE SHEET 10 OF 11 SHEETS STA. TO STA.

F.A.I. RTE.	SECTION	COUNTY	TOTAL SHEETS	SHEET NO.
90/94/290	2013-010R	COOK	747	31
CONTRACT NO. 60W28			ILLINOIS FED. AID PROJECT	