

FLASHING BEACON DETAIL

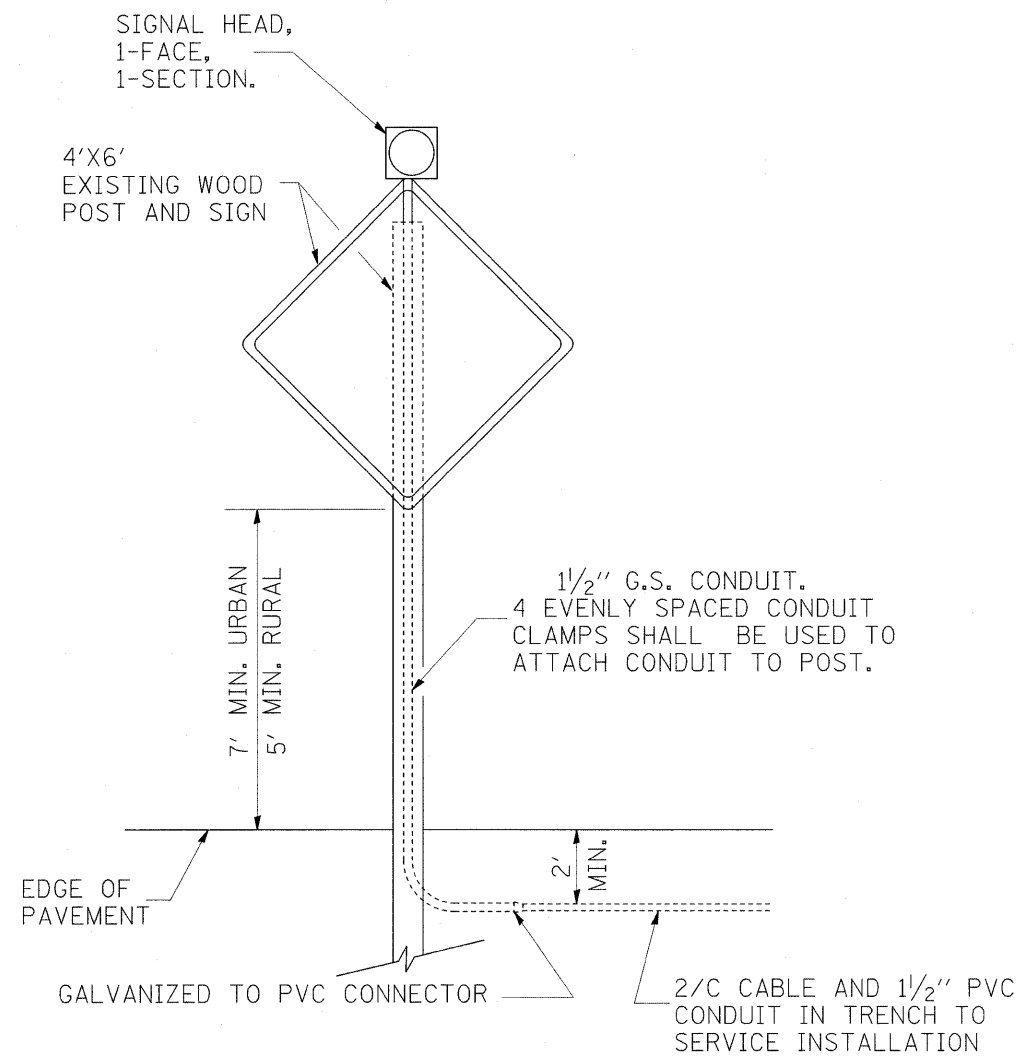

POST MOUNTED FLASHING BEACON

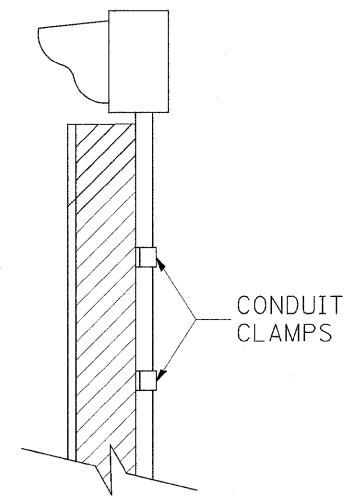

MOUNTING DETAIL

FILE NAME =	USER NAME = colemm	DESIGNED -	REVISED -	STATE OF ILLINOIS DEPARTMENT OF TRANSPORTATION	FLASHING BEACON DETAIL			F.A.P. RTE.	SECTION	COUNTY	TOTAL SHEETS	SHEET NO.
c:\pwork\pwork\colemm\dms43654\d9018	3p2.m32	DRAWN -	REVISED -		869	(1-1,1,3,6)R-1,RS-3(1,3,6)B-2	*	299	104			
PLOT SCALE = 20.0000' / IN.	CHECKED -	REVISED -	REVISED -		* PERRY & FRANKLIN COUNTIES			CONTRACT NO. 98797				
PLOT DATE = 3/24/2011	DATE -	REVISED -	REVISED -		SCALE: 20	SHEET NO. OF SHEETS	STA. TO STA.	ILLINOIS FED. AID PROJECT				