

WITH INTERSECTION TRAFFIC SIGNALS

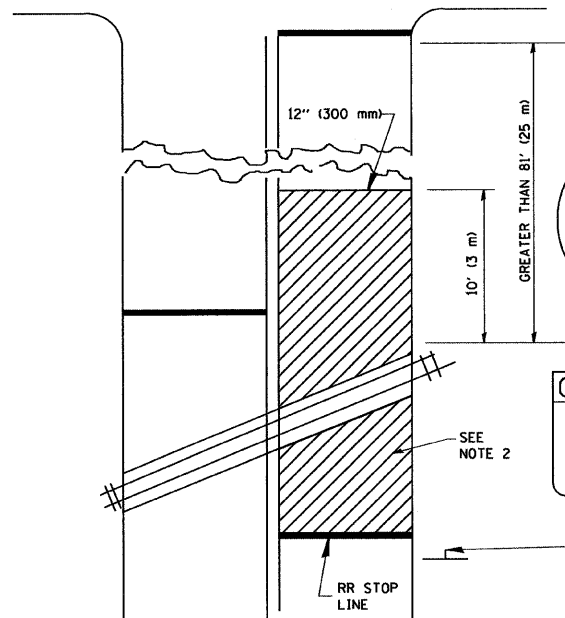

WITH NEAR-SIDE TRAFFIC SIGNALS

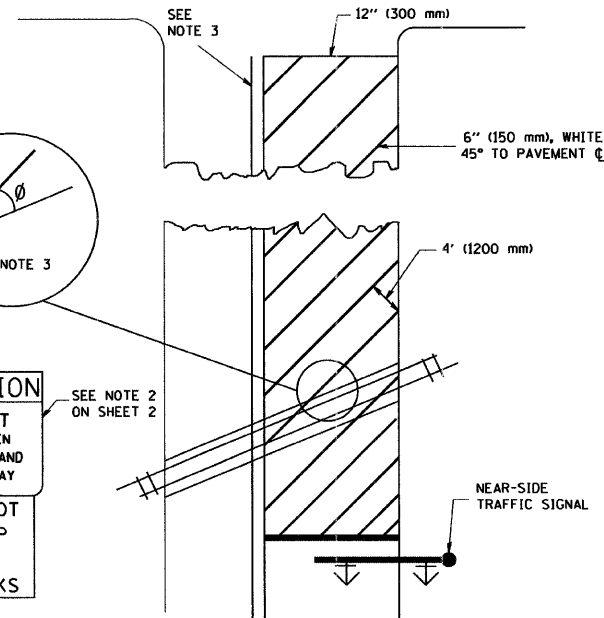

WITH NONSIGNALIZED INTERSECTION
81' (25 m) OR LESS TO CLOSEST RAIL

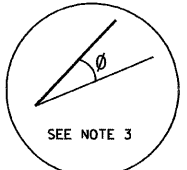
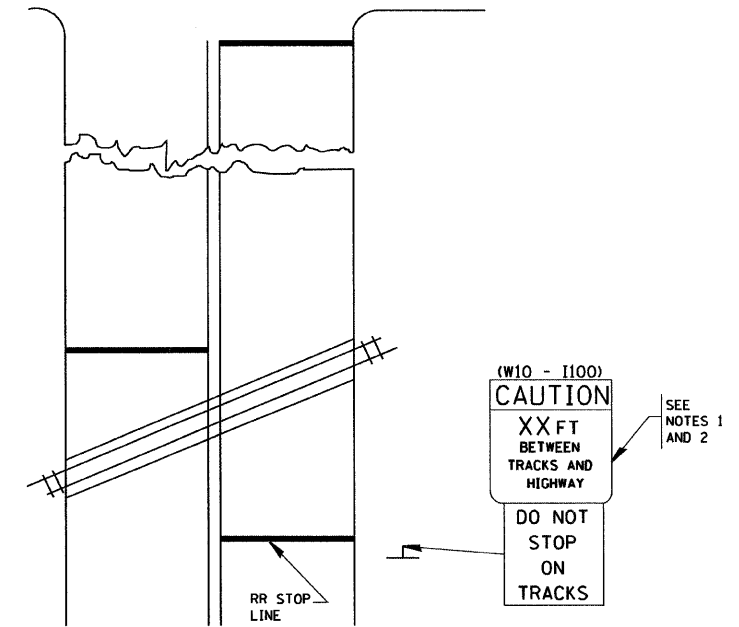

SEE NOTE 2
CAUTION
 XX FT
 BETWEEN
 TRACKS AND
 HIGHWAY
DO NOT
STOP
ON
TRACKS

- NOTES:
- PAVEMENT MARKINGS TO BE INSTALLED ONLY ON APPROACHES TO INTERSECTIONS CONTROLLED BY TRAFFIC SIGNALS WHICH ARE INTERCONNECTED WITH THE RAILROAD WARNING SIGNALS.
 - WHERE NEAR-SIDE TRAFFIC SIGNALS ARE USED, THE PAVEMENT MARKINGS EXTENDS TO THE INTERSECTION.
 - WHERE THE ANGLE BETWEEN THE DIAGONAL STRIPES AND THE TRACK (θ) WOULD BE LESS THAN APPROXIMATELY 20°, THE STRIPES SHOULD BE SLOPED IN THE OPPOSITE DIRECTION FROM THAT SHOWN.

- NOTE:
- DISTANCE TO BE SHOWN ON SIGN MEASURED FROM A POINT 6 FEET (1.8 m) FROM THE RAIL CLOSEST TO THE INTERSECTION TO THE STOP LINE OR CROSSWALK, WHICHEVER IS CLOSEST, ROUNDED DOWN TO THE NEAREST 5 FEET (1.5 m). WHERE THERE IS NO STOP LINE, MEASURE TO POINT WHERE THE DRIVER HAS A VIEW OF APPROACHING TRAFFIC.
 - THE CLEARANCE SIGN IS ALSO TO BE USED AS AN INTERIM MEASURE AT LOCATIONS WITH INTERCONNECTED INTERSECTION TRAFFIC SIGNALS WHERE IT IS PLANNED TO CHANGE THEM TO NEAR-SIDE SIGNALS AT A FUTURE TIME. IN THIS CASE, THE DISTANCE TO BE SHOWN ON THE SIGN IS MEASURED FROM THE EDGE OF THE STRIPED-OUT AREA INSTEAD OF 6 FEET FROM THE RAIL. THE SIGN IS TO BE REMOVED WHEN THE NEAR-SIDE SIGNALS ARE INSTALLED AND THE PAVEMENT MARKINGS EXTEND TO THE INTERSECTION.

ALL DIMENSIONS ARE IN INCHES (MILLIMETERS) UNLESS OTHERWISE SHOWN. *1284 & 2743

FILE NAME = M:\diststd\22x34\to23.dgn	USER NAME = gaglianobt	DESIGNED - DRAWN -	REVISED - REVISED -	01-01-07	STATE OF ILLINOIS DEPARTMENT OF TRANSPORTATION	TYPICAL SUPPLEMENTAL SIGNING AND PAVEMENT MARKING TREATMENT FOR RAILROAD CROSSINGS			F.A.U. RTE.	SECTION	COUNTY	TOTAL SHEETS	SHEET NO.	
	PLOT SCALE = 50.000 ' / IN.	CHECKED -	REVISED -			SCALE: NONE	SHEET NO. 1 OF 1 SHEETS	STA.	TO STA.	*	2011-017-RS	COOK	16	16
	PLOT DATE = 1/4/2008	DATE -	REVISED -								TC-23			
											FED. ROAD DIST. NO. 1	ILLINOIS FED. AID PROJECT		CONTRACT NO. 60P10