

VAULT DOOR AT NORTH SIDE OF WEST ABUTMENT

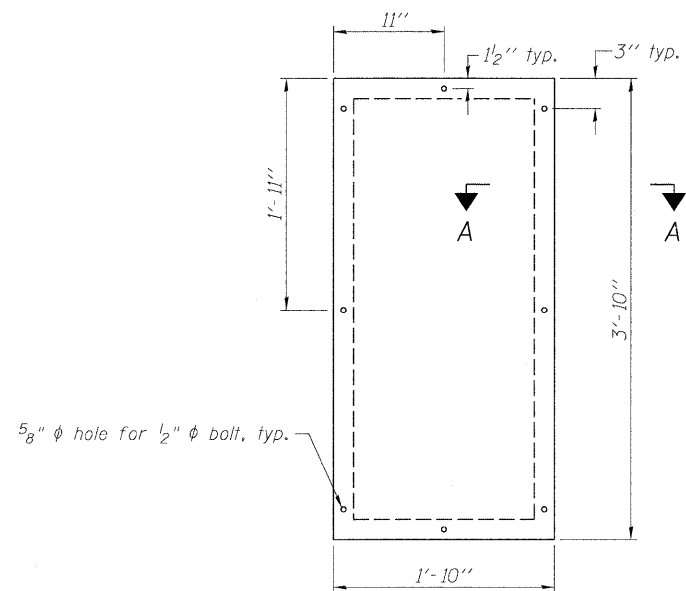

DOOR ELEVATION  
(North Side of West Abutment)

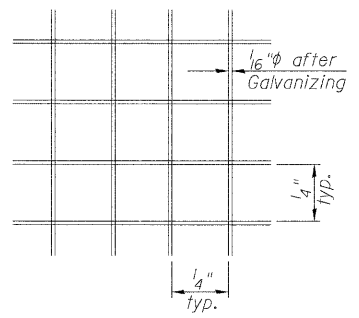

SECTION B-B

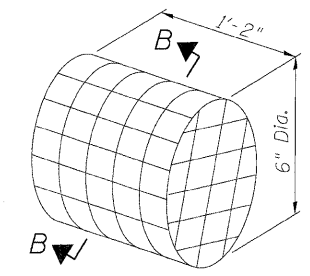

DETAIL OF RODENT SHIELD  
(4 required)

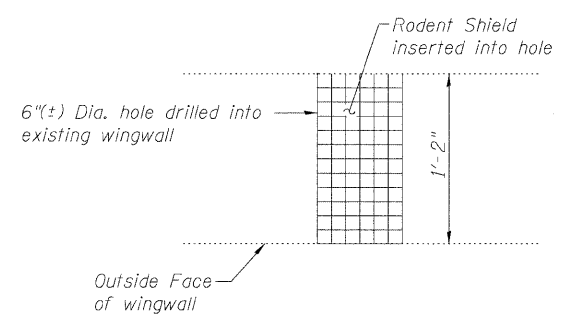

RODENT SHIELD PLACEMENT

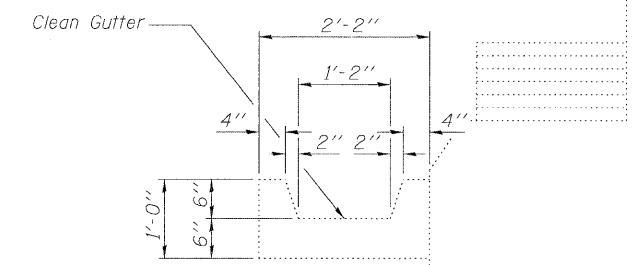

GUTTER AT EAST ABUTMENT

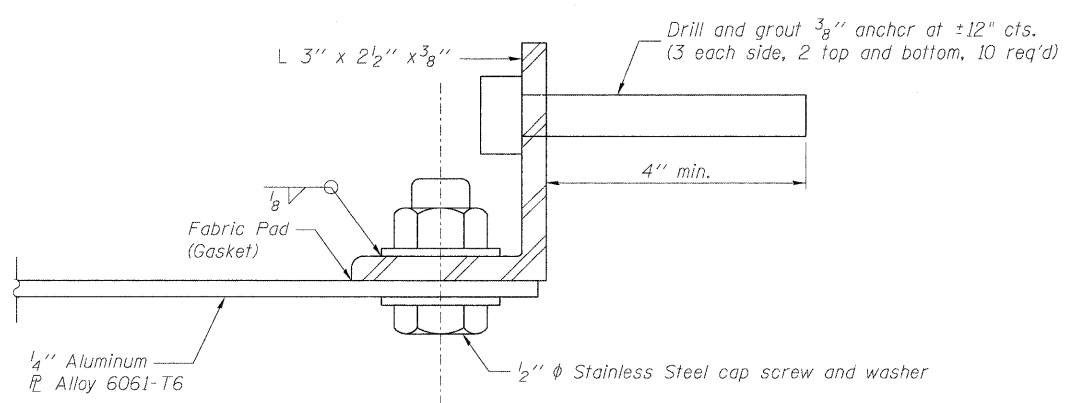

SECTION A-A

Note: Cost of new door and all components including removal of existing door is included in cost of Furnish and Install Access Door.  
Cost of drilling holes and rodent shield included with Furnish and Install Access Door.

BILL OF MATERIAL

ITEM	UNIT	TOTAL
Gutters To Be Cleaned	Foot	70
Furnish and Install Access Door	Each	1