

ROUTE VARIOUS	SECTION 2010-055 BP	COUNTY COOK AND WILL	TOTAL SHEETS 20	SHEET NUMBER 18
------------------	------------------------	-------------------------	--------------------	--------------------

CONTRACT NO. 60L30

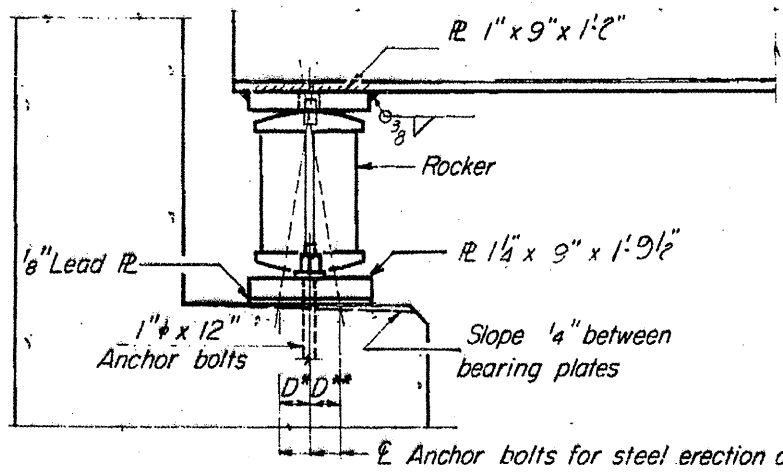

ELEVATION

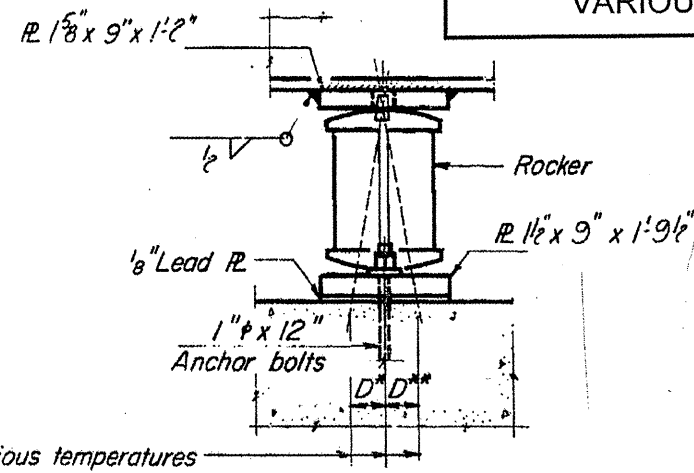

ELEVATION

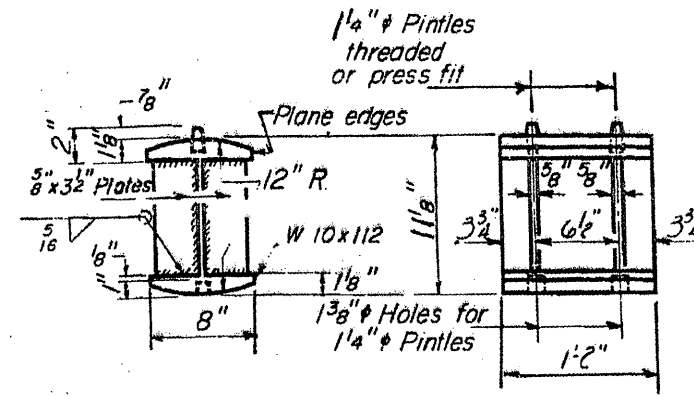

ROCKER

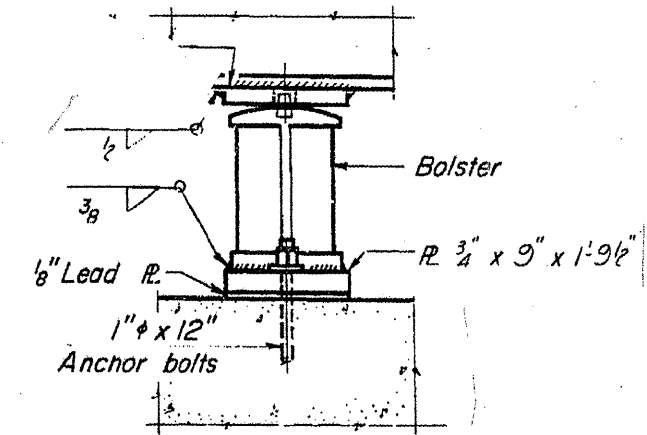

ELEVATION

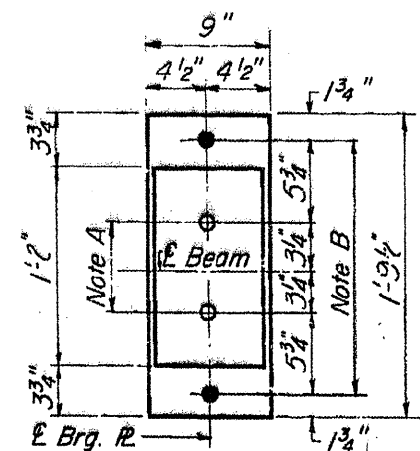

PLAN

AT ABUTMENT

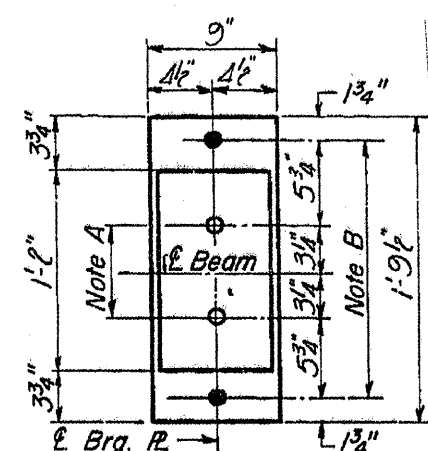

PLAN

AT PIERS 1 & 3

NOTE B
1 1/2" diameter holes for 1" diameter anchor bolts.
16 x 2 1/2" x 2 1/2" radius washers under nut.

BEARING ASSEMBLY DETAILS

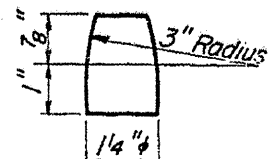

PINTLE

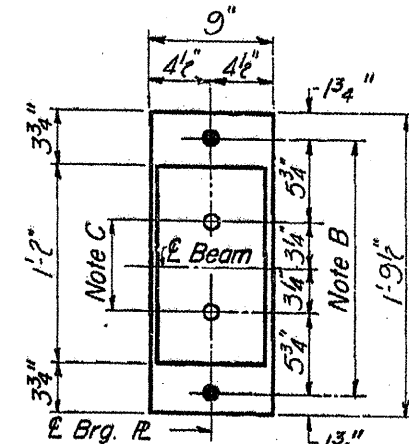

PLAN

AT PIER 2

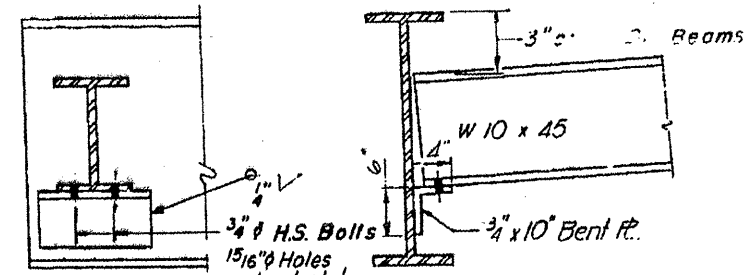

DIAPHRAGM D

1/2" Required

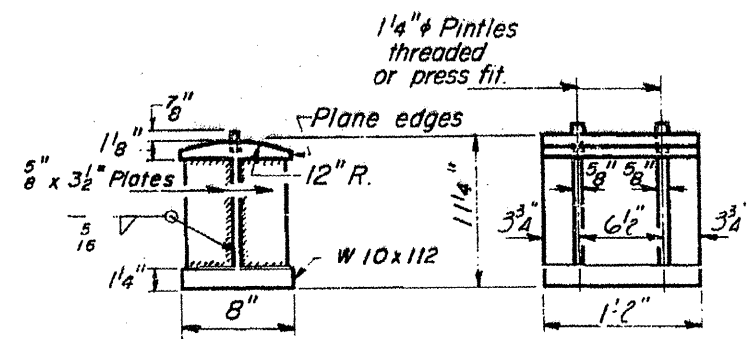

BOLSTER

ILLINOIS DEPARTMENT OF
TRANSPORTATION

EXISTING BRIDGE PLAN
LOCATION 2: SN 099-0105