

STATE OF ILLINOIS
DEPARTMENT OF TRANSPORTATION

F.A.I. RTE.	SECTION	COUNTY	TOTAL SHEETS	SHEET NO.
72	(86-8)BDR1, BJR1, BRR1, BP	SCOTT	45*	1
ILLINOIS			CONTRACT NO. 72136	

* 45 + 3 = 48 TOTAL SHEETS

06-16-2023 LETTING ITEM 244

PROPOSED HIGHWAY PLANS

ROUTE FAI 72 (I 72)
SECTION (86-8)BDR1, BJR1, BRR1, BP
PROJECT COVD-IA52(162)
BRIDGE DECK OVERLAY
SCOTT COUNTY

C-96-073-22

D-96-055-22

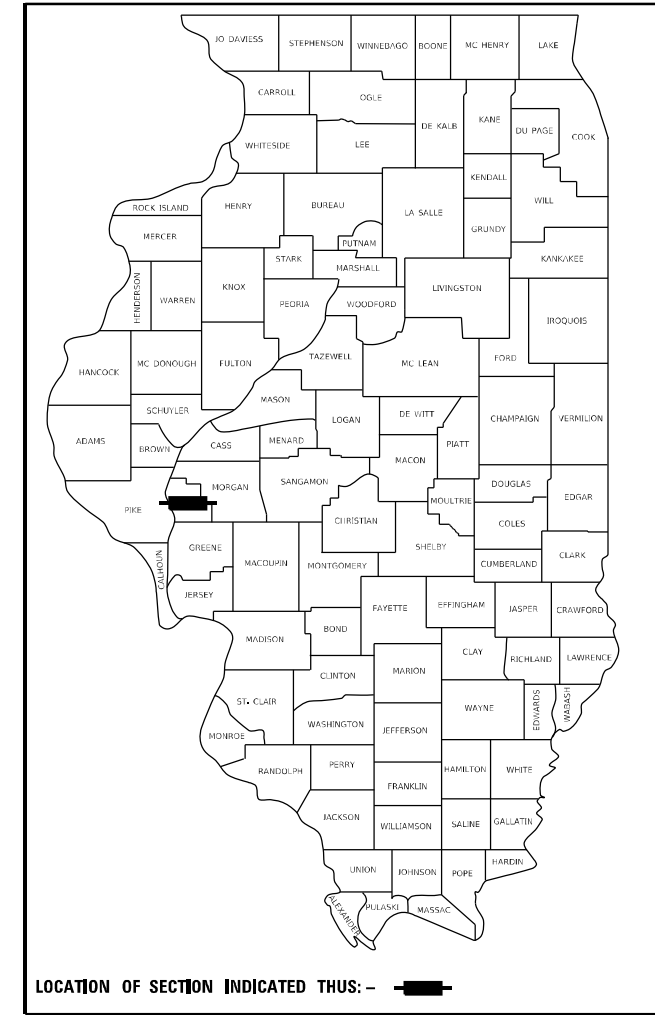

FUNCT. CLASS. = INTERSTATE
ADT = 9,100 (2021)
PV = 63.19%
SU = 5.49%
MU = 31.32%

STATE OF ILLINOIS
DEPARTMENT OF TRANSPORTATION

SUBMITTED December 15, 2022

John P. Meyer
REGIONAL ENGINEER

February 3, 2023
Scott A. Etkin
ENGINEER OF DESIGN AND ENVIRONMENT

February 3, 2023
Stephen M. Smith
DIRECTOR OF HIGHWAYS PROJECT IMPLEMENTATION

PRINTED BY THE AUTHORITY
OF THE STATE OF ILLINOIS

INDEX OF SHEETS

- 1 COVER
- 2 GENERAL NOTES
- 3-6 SUMMARY OF QUANTITIES
- 7-9 SCHEDULE OF QUANTITIES
- 10 TYPICAL SECTIONS
- 11-12 ALIGNMENT & ROAD LAYOUT LOCATION
- 13-14 PLAN
- 15-26 STAGING PLAN
- 27-31 DETAILS
- 32-45 BRIDGE PLANS
- 45A-45C EXISTING PLAN SHEETS

SN 086-0042: STA 45+36 (FAI 72 EB OVER DRAINAGE DITCH)
SN 086-0043: STA 45+36 (FAI 72 WB OVER DRAINAGE DITCH)

SN 086-0040: STA 146+00 (FAI 72 EB OVER TR 55)
SN 086-0041: STA 645+20 (FAI 72 WB OVER TR 55)

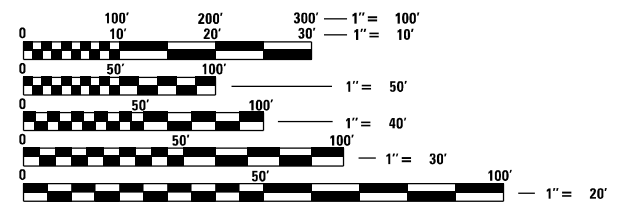

FULL SIZE PLANS HAVE BEEN PREPARED USING STANDARD ENGINEERING SCALES. REDUCED SIZED PLANS WILL NOT CONFORM TO STANDARD SCALES. IN MAKING MEASUREMENTS ON REDUCED PLANS, THE ABOVE SCALES MAY BE USED.

J.U.L.I.E.
JOINT UTILITY LOCATION INFORMATION FOR EXCAVATORS
1-800-892-0123
OR 811

PROJECT ENGINEER: JON KELLEY
PROJECT MANAGER: FRANK CARABALLO

CONTRACT NO. 72136

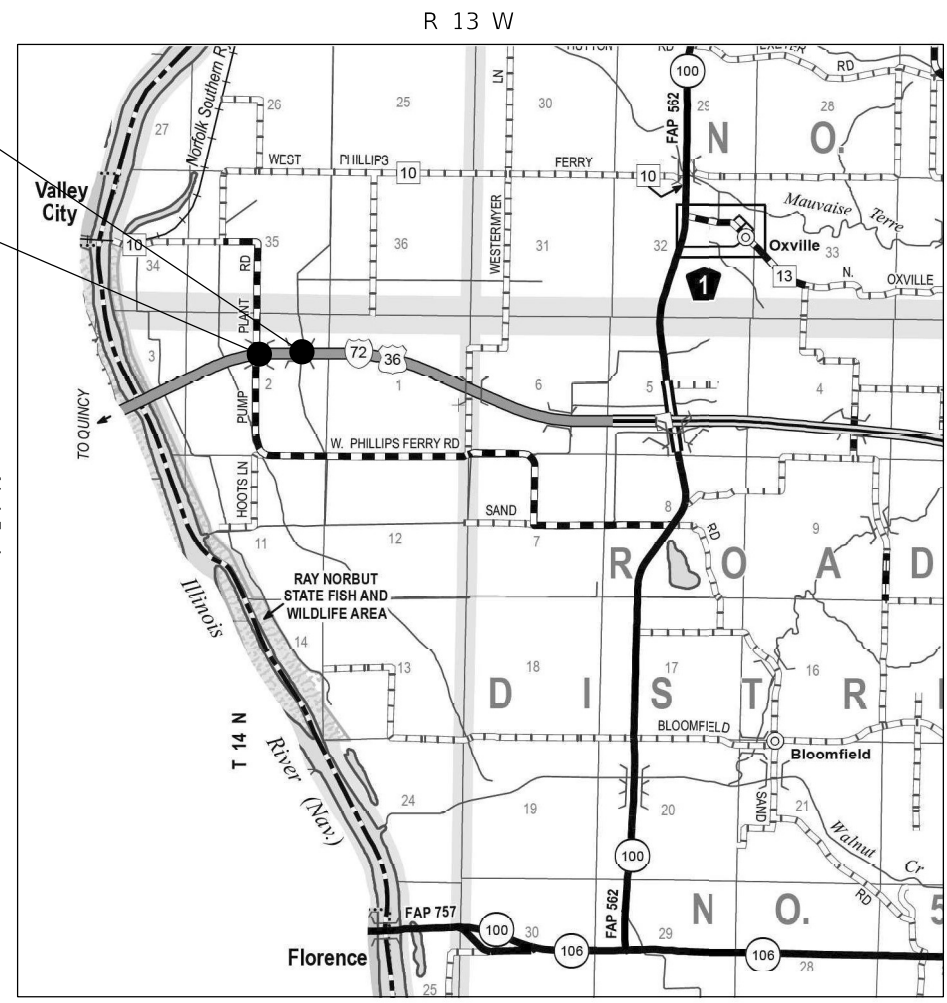

GROSS LENGTH = 3,000.00 FT. = 0.568 MILES
NET LENGTH = 3,000.00 FT. = 0.568 MILES

GENERAL NOTES

1. SYNTHETIC FIBERS ARE NOT REQUIRED IN THE BRIDGE DECK MICROSILICA CONCRETE OVERLAY.
2. ALL TEMPORARY PAVEMENT MARKING TAPE THAT IS TO REMAIN IN PLACE LONGER THAN 14 DAYS SHALL BE TYPE III OR TYPE IV TAPE. TYPE I TEMPORARY PAVEMENT MARKING TAPE MAY BE USED FOR APPLICATIONS OF 14 DAYS OR LESS.

HIGHWAY STANDARDS

000001-06
 001006
 482011-03
 606001-08
 610001-09
 631031-15
 642001-02
 701001-02
 701101-05
 701106-02
 701201-05
 701400-09
 701401-10
 701402-12
 701901-06
 704001-08
 780001-05
 781001-04

APPLICATION RATES

HOT-MIX ASPHALT BASE COURSE 0.056 TON/SQ YD/IN
 HOT-MIX ASPHALT SURFACE/BINDER COURSE 0.056 TON/SQ YD/IN
 AGGREGATE WEDGE SHOULDERS 1.60 TON/CU YD
 BITUMINOUS MATERIALS:
 TACK COAT:
 - BETWEEN HMA LIFTS 0.025 LB/SQ YD
 - ON EXISTING HMA, MILLED SURFACE, CONCRETE, MILLED SURFACE 0.05 LB/SQ YD

MIX REQUIREMENTS

Location(s):	I-72 Mainline
Mixture Use(s):	HMA Surface Course
PG:	SBS PG 70-22 or SBS PG 70-28
Design Air Voids:	4.0% @ N70
Mixture Composition:	IL-9.5
Friction Aggregate:	Mix "D"
Mixture Weight:	112 lb/sy*in
Quality Management:	QC/QA
Sublot Size:	N/A
Material Transfer Device	No

Location(s):	I-72 Mainline
Mixture Use(s):	HMA Binder Course
PG:	SBS PG 70-22 or SBS PG 70-28
Design Air Voids:	4.0% @ N70
Mixture Composition:	IL-9.5
Friction Aggregate:	Mix "D"
Mixture Weight:	112 lb/sy*in
Quality Management:	QC/QA
Sublot Size:	N/A
Material Transfer Device Required:	No

Location(s):	I-72 Shoulder
Mixture Use(s):	HMA Shoulder
PG:	PG 64-22
Design Air Voids:	4.0% @ N50
Mixture Composition:	IL-9.5
Friction Aggregate:	Mix "C"
Mixture Weight:	112 lb/sy*in
Quality Management:	QC/QA
Sublot Size:	N/A
Material Transfer Device	No

Location(s):	I-72 Shoulder
Mixture Use(s):	HMA Base Course
PG:	PG 64-22
Design Air Voids:	4.0% @ N70
Mixture Composition:	IL-19.0
Friction Aggregate:	N/A
Mixture Weight:	112 lb/sy*in
Quality Management:	QC/QA
Sublot Size:	N/A
Material Transfer Device	No

**STATE OF ILLINOIS
 DEPARTMENT OF TRANSPORTATION
 DIVISION OF HIGHWAYS
 DISTRICT 6**

EXAMINED December, 5 20 22

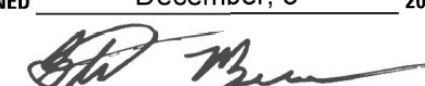
 ENGINEER OF OPERATIONS

EXAMINED December, 13 20 22

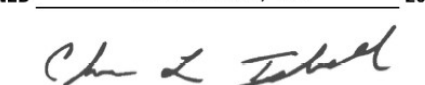
 ENGINEER OF PROJECT IMPLEMENTATION

EXAMINED December, 13 20 22

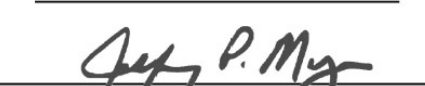
 ENGINEER OF PROGRAM DEVELOPMENT

REV. - MS

MODEL: D:\full FILE: NAME: P:\bldg-cw-bentley.com\FWIDOT\Documents\DOT_Offices\District_6\Projects\0672136\CD\0672136-01-15-2023.dgn

CODE	ITEM	UNIT	TOTAL	6-00324-0100	
				100% FEDERAL	100% FEDERAL
				BRIDGE	BRIDGE
				0047	0047
				SN 086-0040 & SN 086-0041	SN 086-0042 & SN 086-0043
28100107	STONE RIPRAP CL A4	SQ YD	1	1	
35501316	HOT-MIX ASPHALT BASE COURSE, 8"	SQ YD	3915	1780	2135
40600290	BITUMINOUS MATERIALS (TACK COAT)	POUND	5244	1998	3246
40600982	HOT-MIX ASPHALT SURFACE REMOVAL - BUTT JOINT	SQ YD	2773	1247	1526
40600990	TEMPORARY RAMP	SQ YD	1183	348	835
40603208	POLYMERIZED HOT-MIX ASPHALT BINDER COURSE, 1L-9.5, N70	TON	229	79	150
40604162	POLYMERIZED HOT-MIX ASPHALT SURFACE COURSE, 1L-9.5, MIX "D", N70	TON	356	134	222
48101200	AGGREGATE SHOULDER, TYPE B	TON	138	88	50
48203100	HOT-MIX ASPHALT SHOULDERS	TON	261	111	150
48300300	PORTLAND CEMENT CONCRETE SHOULDERS 8"	SQ YD	114	114	0
50102400	CONCRETE REMOVAL	CU YD	21.5	0	21.5
50300255	CONCRETE SUPERSTRUCTURE	CU YD	25	0	25
50300300	PROTECTIVE COAT	SQ YD	3464	1242	2222
50800205	REINFORCEMENT BARS, EPOXY COATED	POUND	3000	0	3000
50800515	BAR SPLICERS	EACH	48	0	48
52000110	PREFORMED JOINT STRIP SEAL	FOOT	168	0	168
60600605	CONCRETE CURB, TYPE B	FOOT	60	0	60

REV. - MS

MODEL: Default
 FILE NAME: P:\Public\sw Bentley.com\PROJECTS\Documents\DOT Office\District 6\Projects\0672136\CADD\0672136-ash-cove.dgn

USER NAME = Frank.Caraballo	DESIGNED -	REVISED -
PLOT SCALE = 100.0000' / in.	DRAWN -	REVISED -
PLOT DATE = 12/14/2022	CHECKED -	REVISED -
	DATE -	REVISED -

STATE OF ILLINOIS
DEPARTMENT OF TRANSPORTATION

SUMMARY OF QUANTITIES			
SCALE:	SHEET	OF	SHEETS

F.A.I. RTE.	SECTION	COUNTY	TOTAL SHEETS	SHEET NO.
72	(86-8)BDR1,BJR1,BRR1,BP	SCOTT	45	3
CONTRACT NO. 72136				
ILLINOIS FED. AID PROJECT				

CODE	ITEM	UNIT	TOTAL	6-00324-0100	
				100% FEDERAL	100% FEDERAL
				BRIDGE	BRIDGE
				0047	0047
				SN 086-0040 & SN 086-0041	SN 086-0042 & SN 086-0043
61000115	TYPE E INLET BOX, STANDARD 610001	EACH	2	2	0
61000335	TYPE G INLET BOX, STANDARD 610001	EACH	2	2	0
63100085	TRAFFIC BARRIER TERMINAL, TYPE 6	EACH	10	6	4
64200116	SHOULDER RUMBLE STRIPS, 16 INCH	FOOT	3146	1182	1964
66201120	CONCRETE SHOULDER CURB	FOOT	120	120	0
67000400	ENGINEER'S FIELD OFFICE, TYPE A	CAL MO	12	6	6
67100100	MOBILIZATION	L SUM	1	0.5	0.5
70100450	TRAFFIC CONTROL AND PROTECTION, STANDARD 701201	L SUM	1	1	
70100800	TRAFFIC CONTROL AND PROTECTION, STANDARD 701401	L SUM	1	0.5	0.5
70107025	CHANGEABLE MESSAGE SIGN	CAL DA	14	7	7
70300100	SHORT TERM PAVEMENT MARKING	FOOT	723	279	444
70300150	SHORT TERM PAVEMENT MARKING REMOVAL	SQ FT	243	93	150
70400100	TEMPORARY CONCRETE BARRIER	FOOT	2100	775	1325
70400200	RELOCATE TEMPORARY CONCRETE BARRIER	FOOT	2100	775	1325
* 78009005	MODIFIED URETHANE PAVEMENT MARKING - LINE 5"	FOOT	5406	2085	3321
* 78100100	RAISED REFLECTIVE PAVEMENT MARKER	EACH	60	23	37
78300200	RAISED REFLECTIVE PAVEMENT MARKER REMOVAL	EACH	60	23	37
78300201	PAVEMENT MARKING REMOVAL, GRINDING	SQ FT	2731	1093	1638

* SPECIALTY ITEM

REV. - MS

MODEL: Default
FILE NAME: P:\Public\sw Bentley.com\PROJECTS\DOT Documents\DOT Offices\District 6\Projects\0672136\CADD\0672136-ah-cove.dgn

USER NAME = Frank.Caraballo	DESIGNED -	REVISED -
	DRAWN -	REVISED -
PLOT SCALE = 100.0000' / in.	CHECKED -	REVISED -
PLOT DATE = 12/14/2022	DATE -	REVISED -

**STATE OF ILLINOIS
DEPARTMENT OF TRANSPORTATION**

SUMMARY OF QUANTITIES

SCALE: SHEET OF SHEETS STA. TO STA.

F.A.I. RTE.	SECTION	COUNTY	TOTAL SHEETS	SHEET NO.
72	(86-8)BDR1,BJR1,BRR1,BP	SCOTT	45	4
			CONTRACT NO. 72136	
ILLINOIS FED. AID PROJECT				

CODE	ITEM	UNIT	TOTAL	6-00324-0100	
				100% FEDERAL	
				BRIDGE	
				0047	0047
				SN 086-0040 & SN 086-0041	SN 086-0042 & SN 086-0043
X1400432	REMOVE AND REINSTALL SHOULDER INLET DRAIN PIPE AND CONNECTION	EACH	4	4	0
X4401198	HOT-MIX ASPHALT SURFACE REMOVAL, VARIABLE DEPTH	SQ YD	3915	1780	2135
X5030250	BRIDGE DECK GROOVING (LONGITUDINAL)	SQ YD	2201	873	1328
* X5060601	CONTAINMENT AND DISPOSAL OF NON-LEAD PAINT CLEANING RESIDUES NO. 1	LSUM	1	0	1
* X5060602	CONTAINMENT AND DISPOSAL OF NON-LEAD PAINT CLEANING RESIDUES NO. 2	LSUM	1	0	1
X6050700	REMOVE INLET BOX	EACH	4	4	0
X6024503	INLETS TO BE ADJUSTED WITH NEW FRAME AND GRATE (SPECIAL)	EACH	8	0	8
X6320100	GUARDRAIL REMOVAL, SPECIAL	FOOT	475	275	200
X7010208	TRAFFIC CONTROL AND PROTECTION, STANDARD 701402 (SPECIAL)	EACH	2	1	1
X7200201	WIDTH RESTRICTION SIGNING	LSUM	1	0.5	0.5
Z0001495	BRIDGE APPROACH SHOULDER REMOVAL	SQ YD	114	114	0
Z0001800	APPROACH SLAB REPAIR (PARTIAL DEPTH)	SQ YD	40	0	40
Z0010501	CLEANING AND PAINTING STEEL BRIDGE NO. 1	LSUM	1	0	1
* Z0010502	CLEANING AND PAINTING STEEL BRIDGE NO. 2	LSUM	1	0	1
* Z0012130	BRIDGE DECK SCARIFICATION 3/4"	SQ YD	3426	1242	2184
Z0012166	BRIDGE DECK MICROSILICA OVERLAY 2 3/4"	SQ YD	3426	1242	2184
Z0012500	CONCRETE CURB REPAIR	FOOT	24	0	24

* SPECIALTY ITEM

REV. - MS

MODEL: Default
FILE NAME: P:\Public\dw Bentley.com PWD\DOT\Documents\DOT_Offices\District_6\Projects\0672136\CADD\0672136-ash-cove.dgn

USER NAME = Frank.Caraballo	DESIGNED -	REVISED -
	DRAWN -	REVISED -
PLOT SCALE = 100.0000' / in.	CHECKED -	REVISED -
PLOT DATE = 12/14/2022	DATE -	REVISED -

**STATE OF ILLINOIS
DEPARTMENT OF TRANSPORTATION**

SUMMARY OF QUANTITIES

SCALE: SHEET OF SHEETS STA. TO STA.

F.A.I. RTE.	SECTION	COUNTY	TOTAL SHEETS	SHEET NO.
72	(86-8)BDR1,BJR1,BRR1,BP	SCOTT	45	5
CONTRACT NO. 72136				
ILLINOIS FED. AID PROJECT				

CODE	ITEM	UNIT	TOTAL	6-00324-0100	
				100% FEDERAL	100% FEDERAL
				BRIDGE	BRIDGE
				0047	0047
				SN 086-0040 & SN 086-0041	SN 086-0042 & SN 086-0043
Z0012754	STRUCTURAL REPAIR OF CONCRETE (DEPTH EQUAL TO OR LESS THAN 5 INCHES)	SQ FT	283	0	283
Z0016002	DECK SLAB REPAIR (FULL DEPTH, TYPE II)	SQ YD	37	5	32
Z0029090	DIAMOND GRINDING (BRIDGE SECTION)	SQ YD	3141	1150	1991
∅ Z0076600	TRAINEES	HOUR	1500	1500	
Z0041895	POLYMER CONCRETE	CU FT	41	41	0
∅ Z0076604	TRAINEES TRAINING PROGRAM GRADUATE	HOUR	1500	1500	

∅ 0042

REV. - MS

MODEL: Default
 FILE NAME: P:\Users\sw_bentley.com\PWIDOT\Documents\DOT_Offices\District_6\Projects\0672136\CADD\0672136-ah-cove.dgn

USER NAME = Frank.Caraballo	DESIGNED -	REVISED -
	DRAWN -	REVISED -
PLOT SCALE = 100.0000' / in.	CHECKED -	REVISED -
PLOT DATE = 12/14/2022	DATE -	REVISED -

**STATE OF ILLINOIS
DEPARTMENT OF TRANSPORTATION**

SUMMARY OF QUANTITIES

SCALE: SHEET OF SHEETS STA. TO STA.

F.A.I. RTE.	SECTION	COUNTY	TOTAL SHEETS	SHEET NO.
72	(86-8)BDR1,BJR1,BRR1,BP	SCOTT	45	6
			CONTRACT NO. 72136	
ILLINOIS FED. AID PROJECT				

PAVING SCHEDULE												
LOCATION			LENGTH FOOT	WIDTH FOOT	40600290	40600982	40604162	40603208	48101200	48203100	64200116	
STATION	TO	STATION			BITUMINOUS MATERIALS (TACK COAT)	HOT-MIX ASPHALT SURFACE REMOVAL - BUTT JOINT	POLYMERIZED HOT-MIX ASPHALT SURFACE COURSE, IL-9.5, MIX "D", N70	POLYMERIZED HOT-MIX ASPHALT BINDER COURSE, IL-9.5, N70	AGGREGATE SHOULDER, TYPE B	HOT-MIX ASPHALT SHOULDERS	SHOULDER RUMBLE STRIPS, 16 INCH	
			POUND	SQ YD	TON	TON	TON	TON	TON	FOOT		
WB I-72: SN 086-0041												
642+78	-	644+33	155	24	186		35		23		310	
642+78	LT -	644+52	LT 174	10	87					17		
642+78	RT -	644+50	RT 172	8	69					13		
642+78	-	643+36	58	42		271						
643+36	-	644+33	97	42	204			29				
644+40	LT -	644+52	LT 12	10	6			3				
644+38	RT -	644+50	RT 12	8	5			2				
645+81	LT -	646+00	LT 19	10	10			2				
645+81	RT -	646+00	RT 19	6	6			1				
646+00	-	646+87	87	40	174			16				
646+87	-	647+55	68	40		303						
646+00	-	647+55	155	24	186		35		23		310	
645+81	LT -	647+55	LT 174	10	87					17		
645+81	RT -	647+55	RT 174	6	53					10		
SN 086-0041 TOTAL					1073		70	53	46	57	620	
WB I-72: SN 086-0043												
41+84	-	44+14	230	24	276		52		12		460	
41+84	LT -	44+14	LT 230	10	115					22		
41+84	RT -	44+14	RT 230	6	69					13		
41+84	-	42+82	98	40		436						
42+82	-	44+14	132	40	264			30				
46+62	-	47+88	126	40	252			16				
47+88	-	48+92	104	40		463						
46+62	-	48+92	230	24	276		52		12		460	
46+62	LT -	48+92	LT 230	10	115					22		
46+62	RT -	48+92	RT 230	6	69					13		
SN 086-0043 TOTAL					1436		104	46	24	70	920	
EB I-72: SN 086-0040												
143+54	-	145+09	155	24	186		35		23		310	
143+54	LT -	145+33	LT 179	8	72					14		
143+54	RT -	145+27	RT 173	10	87					17		
143+54	-	144+21	67	42		313						
144+21	-	145+09	88	42	185			16				
145+09	LT -	145+33	LT 24	8	10			1				
145+09	RT -	145+27	RT 18	10	9			1				
146+60	LT -	146+77	LT 17	6	6			1				
146+56	RT -	146+77	RT 21	10	11			1				
146+77	-	147+22	45	40	90			6				
147+22	-	148+03	81	40		360						
146+77	-	148+03	126	24	152		29		19		252	
146+60	LT -	148+03	LT 143	6	43					9		
146+56	RT -	148+03	RT 147	10	74					14		
SN 086-0040 TOTAL					925		64	26	42	54	562	
EB I-72: SN 086-0042												
41+94	-	44+15	221	24	266		50		11		442	
41+94	LT -	44+15	LT 221	6	67					13		
41+94	RT -	44+15	RT 221	10	111					21		
41+94	-	42+54	60	40		267						
42+54	-	44+15	161	40	322			38				
46+61	-	48+81	220	40	440			66				
48+81	-	49+62	81	40		360						
46+61	-	49+62	301	24	362		68		15		602	
46+61	LT -	49+62	LT 301	6	91					17		
46+61	RT -	49+62	RT 301	10	151					29		
SN 086-0042 TOTAL					1810		118	104	26	80	1044	
TOTALS					5,244		2,773	356	229	138	261	3,146

MODEL: Default
 FILE: Mainfile.pxl
 USER: p:\public\paw.bentley.com\p\windot\Documents\DOT\Office\Dir\dir: E:\Project\0672136\CADD\data_5510\CADD\sheet\0672136\sheet-core.dgn

USER NAME = Frank.Caraballo	DESIGNED -	REVISED -
PLOT SCALE = 100,0000 ' / in.	DRAWN -	REVISED -
PLOT DATE = 12/14/2022	CHECKED -	REVISED -
	DATE -	REVISED -

STATE OF ILLINOIS
DEPARTMENT OF TRANSPORTATION

SCHEDULES OF QUANTITIES			
SCALE:	SHEET	OF	SHEETS
	STA.	TO	STA.

F.A.I. RTE.	SECTION	COUNTY	TOTAL SHEETS	SHEET NO.
72	(86-8)BDR1,BJR1,BRR1,BP	SCOTT	45	7
CONTRACT NO. 72136				
ILLINOIS		FED. AID PROJECT		

HMA SHOULDER REPLACEMENT FOR STAGE TRAFFIC							
LOCATION				WIDTH	35501316	X4401198	
STATION	TO	STATION			HOT-MIX ASPHALT BASE COURSE, 8"	HOT-MIX ASPHALT SURFACE REMOVAL, VARIABLE DEPTH	
				FOOT	SQ YD	SQ YD	
WB I-72 SN 086-0041							
642+45	LT	-	644+52	LT	10	230.0	230.0
645+81	LT	-	648+48	LT	10	297.0	297.0
642+45	RT	-	644+50	RT	8	183.0	183.0
645+81	RT	-	648+48	RT	6	178.0	178.0
<i>SN 086-0041 SUB-TOTAL</i>						<i>888.0</i>	<i>888.0</i>
WB I-72 SN 086-0043							
41+30	LT	-	43+97	LT	10	297.0	297.0
46+79	LT	-	50+15	LT	10	374.0	374.0
41+30	RT	-	43+97	RT	6	178.0	178.0
47+02	RT	-	50+15	RT	6	209.0	209.0
<i>SN 086-0043 SUB-TOTAL</i>						<i>1058.0</i>	<i>1058.0</i>
EB I-72 SN 086-0040							
142+60	LT	-	145+33	LT	8	243.0	243.0
146+60	LT	-	148+55	LT	6	130.0	130.0
142+60	RT	-	145+27	RT	10	297.0	297.0
146+56	RT	-	148+55	RT	10	222.0	222.0
<i>SN 086-0040 SUB-TOTAL</i>						<i>892.0</i>	<i>892.0</i>
EB I-72 SN 086-0042							
40+60	LT	-	43+97	LT	6	225.0	225.0
46+79	LT	-	49+47	LT	6	179.0	179.0
40+60	RT	-	43+97	RT	10	375.0	375.0
46+79	RT	-	49+47	RT	10	298.0	298.0
<i>SN 086-0042 SUB-TOTAL</i>						<i>1077.0</i>	<i>1077.0</i>
TOTALS						3915.0	3915.0

TEMPORARY RAMPS							
LOCATION			DESCRIPTION	LENGTH	WIDTH	40600990	
STATION	TO	STATION		FOOT	FOOT	TEMPORARY RAMP SQ YD	
<i>1:40 Taper Rate</i>							
WB I-72 SN 086-0041							
	644+17	-	644+32	MAINLINE	15	24	40
LT	644+17	-	644+51	SHOULDER	34	10	38
RT	644+17	-	644+52	SHOULDER	34	8	31
	645+99	-	646+14	MAINLINE	15	24	40
LT	645+81	-	646+15	SHOULDER	34	10	38
RT	645+81	-	646+15	SHOULDER	34	6	23
<i>SN 086-0041 SUB-TOTAL</i>							<i>210</i>
WB I-72 SN 086-0043							
	42+99	-	43+14	MAINLINE	15	24	40
LT	42+99	-	43+97	SHOULDER	98	10	109
RT	42+99	-	43+97	SHOULDER	98	6	66
	47+61	-	47+76	MAINLINE	15	24	40
LT	46+79	-	47+76	SHOULDER	97	10	108
RT	46+79	-	47+76	SHOULDER	97	6	65
<i>SN 086-0043 SUB-TOTAL</i>							<i>428</i>
EB I-72 SN 086-0040							
	144+94	-	145+09	MAINLINE	15	24	40
LT	144+94	-	145+09	SHOULDER	15	8	14
RT	144+94	-	145+09	SHOULDER	15	10	17
	146+77	-	146+92	MAINLINE	15	24	40
LT	146+77	-	146+92	SHOULDER	15	6	10
RT	146+77	-	146+92	SHOULDER	15	10	17
<i>SN 086-0040 SUB-TOTAL</i>							<i>138</i>
EB I-72 SN 086-0042							
	42+99	-	43+14	MAINLINE	15	24	40
LT	42+99	-	43+97	SHOULDER	98	6	66
RT	42+99	-	43+97	SHOULDER	98	10	109
	47+61	-	47+76	MAINLINE	15	24	40
	46+79	-	47+76	SHOULDER	97	8	87
	46+79	-	47+76	SHOULDER	97	6	65
<i>SN 086-0042 SUB-TOTAL</i>							<i>407</i>
TOTAL							1183

INLETS TO BE ADJUSTED SCHEDULE							
LOCATION				WIDTH	60600605	X6024503	Z0012500
STATION	TO	STATION			CONCRETE CURB, TYPE B	INLETS TO BE ADJUSTED WITH NEW FRAME AND GRATE (SPECIAL)	CONCRETE CURB REPAIR
				FOOT	FOOT	EACH	FOOT
WB I-72 SN 086-0043							
43+97	LT	-	44+03	LT	10		6
43+97	RT	-	44+03	RT	8		6
46+72	LT	-	46+87	LT	10	15	1
46+72	RT	-	46+87	RT	6	15	1
<i>SN 086-0043 SUB-TOTAL</i>						<i>30.0</i>	<i>12.0</i>
EB I-72 SN 086-0042							
43+97	LT	-	44+12	LT	8	15	1
43+97	RT	-	44+12	RT	10	15	1
46+72	LT	-	46+78	LT	6		6
46+72	RT	-	46+78	RT	10		6
<i>SN 086-0042 SUB-TOTAL</i>						<i>30.0</i>	<i>12.0</i>
TOTALS						60.0	24.0

GUARDRAIL SCHEDULE						
LOCATION			63100085	X6320100		
STATION	TO	STATION	TRAFFIC BARRIER TERMINAL, TYPE 6	GUARDRAIL REMOVAL, SPECIAL		
			EACH	FOOT		
WB I-72 SN 086-0041						
644+31	LT		644+68	LT	1	37.5
645+65.0	LT	-	646+15.0	LT	1	50.0
644+28.5	RT	-	644+66.0	RT	1	37.5
645+64.0	RT	-	646+14.0	RT	1	50.0
<i>SN 086-0041 SUB-TOTAL</i>					<i>4</i>	<i>175</i>
WB I-72 SN 086-0043						
46+57.0	LT	-	47+07.0	LT	1	50.0
46+57.0	RT	-	47+07.0	RT	1	50.0
<i>SN 086-0043 SUB-TOTAL</i>					<i>2</i>	<i>100</i>
EB I-72 SN 086-0040						
144+99	LT		145+49	LT	1	50.0
145+04.5	RT	-	145+42.0	RT	1	50.0
<i>SN 086-0040 SUB-TOTAL</i>					<i>2</i>	<i>100</i>
EB I-72 SN 086-0042						
43+69.0	LT	-	44+19.0	LT	1	50.0
43+69.0	RT	-	44+19.0	RT	1	50.0
<i>SN 086-0042 SUB-TOTAL</i>					<i>2</i>	<i>100</i>
TOTALS					10	475

MODEL: Default
 FILE: Mainfile.pxl
 PROJECT: \\paw.bentley.com\PIV\DOT\Documents\DOT Office\Dir\dir: E:\Project\0672136\CADD\data_5510\CADD\sheet\0672136-sht-core.dgn

USER NAME = Frank.Caraballo	DESIGNED -	REVISED -
DRAWN -	REVISED -	
PLOT SCALE = 100,0000' / in.	CHECKED -	REVISED -
PLOT DATE = 12/14/2022	DATE -	REVISED -

**STATE OF ILLINOIS
DEPARTMENT OF TRANSPORTATION**

SCHEDULES OF QUANTITIES

SCALE: SHEET OF SHEETS STA. TO STA.

F.A.I. RTE.	SECTION	COUNTY	TOTAL SHEETS	SHEET NO.
72	(86-8)BDR1,BR1,BRR1,BP	SCOTT	45	8
CONTRACT NO. 72136				
ILLINOIS FED. AID PROJECT				

BRIDGE APPROACH SHOULDERS													
LOCATION			LENGTH	WIDTH	48300300	61000115	61000335	66201120	Z0001495	X1400432	X6050700		
STATION	TO	STATION			PORTLAND CEMENT CONCRETE SHOULDERS 8"	TYPE E INLET BOX, STANDARD 610001	TYPE G INLET BOX, STANDARD 610001	CONCRETE SHOULDER CURB	BRIDGE APPROACH SHOULDER REMOVAL	REMOVE AND REINSTALL SHOULDER INLET DRAIN PIPE AND CONNECTION	REMOVE INLET BOX		
			FOOT	FOOT	SQ YD	EACH	EACH	FOOT	SQ YD	EACH	EACH		
WB I-72 SN 086-0041													
644+52	LT	-	644+67	LT	15	10	16.7			15	16.7		
644+50.0	RT	-	644+65	RT	15	8	13.3		1	15	13.3	1	
645+68.0	LT	-	645+83	LT	15	10	16.7			15	16.7		
645+68.0	RT	-	645+83	RT	15	6	10.0		1	15	10.0	1	
<i>SN 086-0041 SUB-TOTAL</i>							56.7	0.0	2.0	60.0	56.7	2.0	2.0
EB I-72 SN 086-0040													
145+33	LT	-	145+48	LT	15	8	13.3			15	13.3		
145+27.0	RT	-	145+42	RT	15	10	16.7	1		15	16.7	1	
146+47.0	LT	-	146+62	LT	15	6	10.0			15	10.0		
146+43.0	RT	-	146+58	RT	15	10	16.7	1		15	16.7	1	
<i>SN 086-0040 SUB-TOTAL</i>							56.7	2.0	0.0	60.0	56.7	2.0	2.0
TOTALS							114.0	2.0	2.0	120.0	114.0	4.0	4.0

PAVEMENT MARKING SCHEDULE												
LOCATION			DESCRIPTION	70300100	70300150	78009005	78100100	78300200	78300201			
STATION	TO	STATION		SHORT-TERM PAVEMENT MARKING	SHORT-TERM PAVEMENT MARKING REMOVAL	MODIFIED URETHANE PAVEMENT MARKING - LINE 5"	RAISED REFLECTIVE PAVEMENT MARKER	RAISED REFLECTIVE PAVEMENT MARKER REMOVAL	PAVEMENT MARKING REMOVAL GRINDING			
			TYPE	COLOR	FOOT	SQ FT	FOOT	EACH	EACH	SQ FT		
WB I-72 SN 086-0041 & 086-0043												
642+78	LT	-	647+55	LT	SOLID EDGE LINE	WHITE	47.7	16	477		251	
642+78	CL	-	647+55	CL	SKIP DASH	WHITE	47.7	16	120	12	50	
642+78	RT	-	647+55	RT	SOLID EDGE LINE	YELLOW	47.7	16	477		251	
<i>SN 086-0041 TOTAL</i>							144.0	48	1074	12	552	
<i>STATION EQUATION STA 653+18.99 = STA 36+25.00</i>												
41+84	LT	-	48+92	LT	SOLID EDGE LINE	WHITE	70.8	24	708		368	
41+84	CL	-	48+92	CL	SKIP DASH	WHITE	70.8	24	177	18	74	
41+84	RT	-	48+92	RT	SOLID EDGE LINE	YELLOW	70.8	24	708		368	
<i>SN 086-0043 TOTAL</i>							213.0	72	1593	18	810	
EB I-72 SN 086-0040 & SN 086-0042												
143+54	LT	-	148+03	LT	SOLID EDGE LINE	WHITE	44.9	15	449		247	
143+54	CL	-	148+03	CL	SKIP DASH	WHITE	44.9	15	113	11	47	
143+54	RT	-	148+03	RT	SOLID EDGE LINE	YELLOW	44.9	15	449		247	
<i>SN 086-0040 TOTAL</i>							135.0	45	1011	11	541	
<i>STATION EQUATION STA 153+93.08 = STA 154+02.17</i>												
41+94	LT	-	49+62	LT	SOLID EDGE LINE	WHITE	76.8	26	768		374	
41+94	CL	-	49+62	CL	SKIP DASH	WHITE	76.8	26	192	19	80	
41+94	RT	-	49+62	RT	SOLID EDGE LINE	YELLOW	76.8	26	768		374	
<i>SN 086-0042 TOTAL</i>							231.0	78	1728	19	828	
TOTALS							723	243	5,406	60	60	2,731

REV. - MS

MODEL: Default
 FILE NAME: P:\Illinois\Bentley.com\pwwd\Documents\DOT_Offices\Dircc\B\Projects\0672136\CADD\086_5310\CAD\Sheets\0672136-ah-cove.dgn

USER NAME = Frank.Caraballo	DESIGNED -	REVISED -
	DRAWN -	REVISED -
PLOT SCALE = 100.0000' / in.	CHECKED -	REVISED -
PLOT DATE = 12/14/2022	DATE -	REVISED -

**STATE OF ILLINOIS
DEPARTMENT OF TRANSPORTATION**

SCHEDULES OF QUANTITIES

SCALE: SHEET OF SHEETS STA. TO STA.

F.A.I. RTE.	SECTION	COUNTY	TOTAL SHEETS	SHEET NO.
72	(86-8)BDR1,BJR1,BRR1,BP	SCOTT	45	9
CONTRACT NO. 72136				
ILLINOIS FED. AID PROJECT				

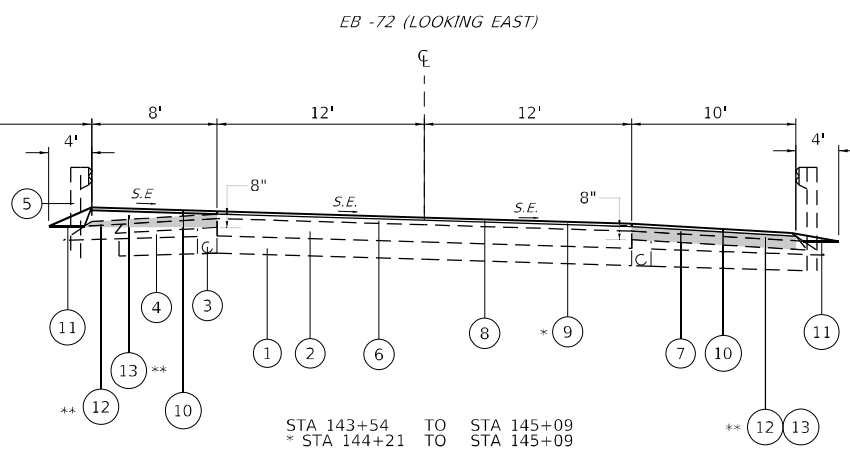
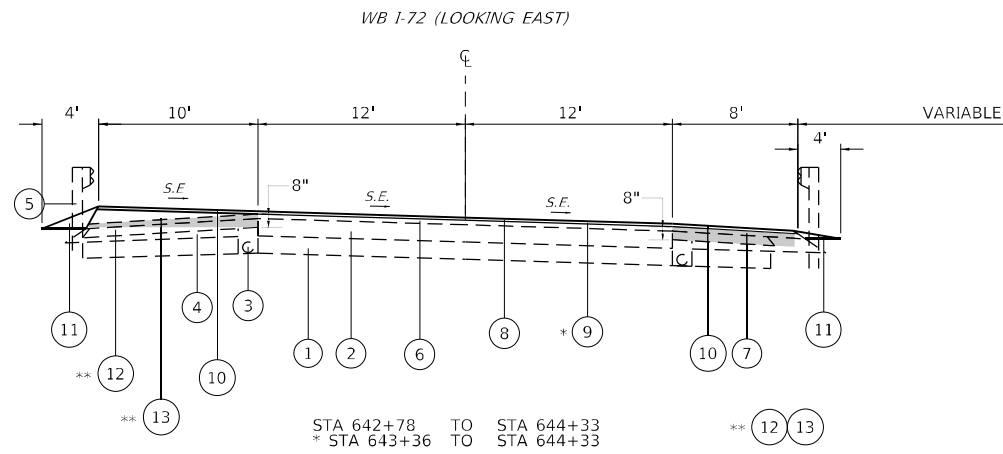

- NOTES:**
- * DIP CORRECTION
 - ** SHOULDER REPLACEMENT FOR STAGE TRAFFIC (SEE SCHEDULE OF QUANTITIES)
- LEGEND:**
- SHOULDER RECONSTRUCTION & SUPER ELEVATION CORRECTION (SEE 12 13)

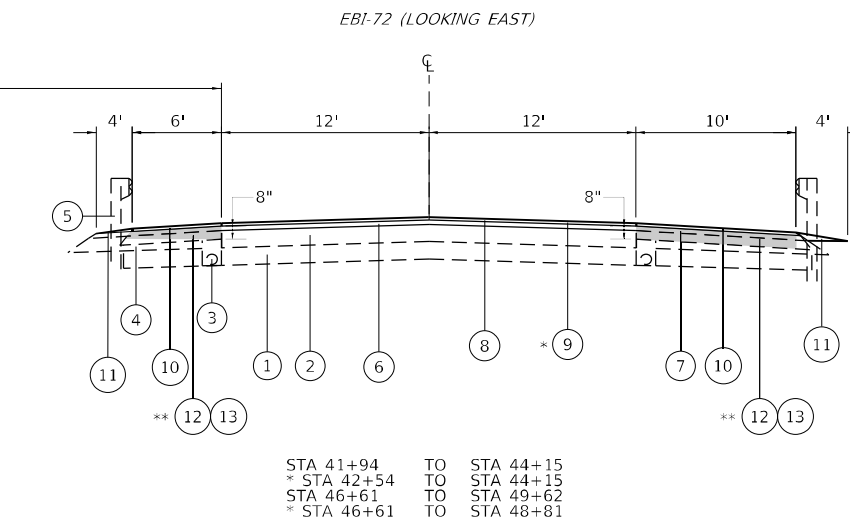
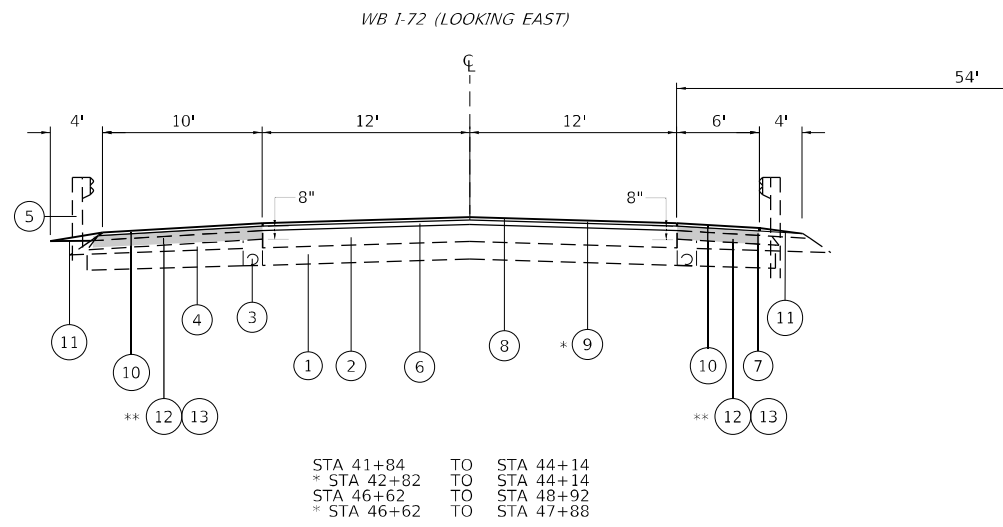
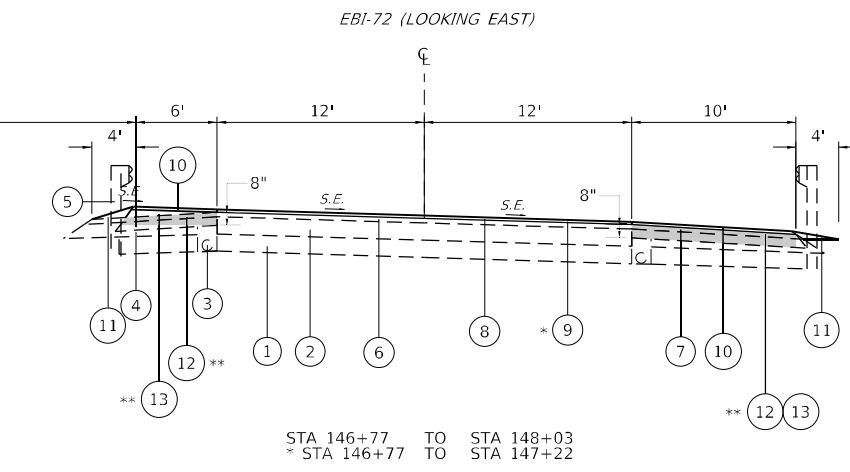
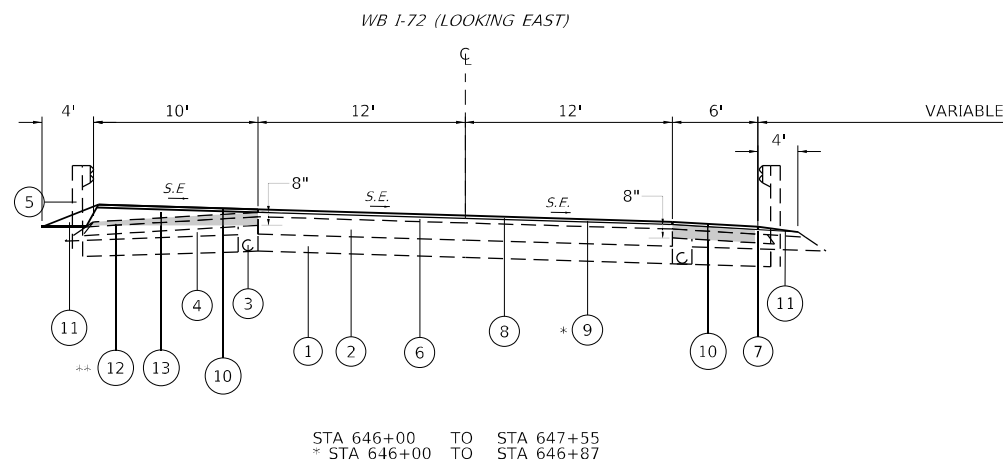

- LEGEND**
- 1 EXIST. LIME MODIFIED SOIL - 12"
 - 2 EXIST. BITUMINOUS CONCRETE PAVEMENT, FULL DEPTH - 15" (13½" BINDER, 1½" SURFACE)
 - 3 EXIST. PIPE UNDERDRAINS - 4"
 - 4 EXIST. LIME MODIFIED SOIL / SUB-BASE GRANULAR MATERIAL
 - 5 EXIST. STEEL PLATE BEAM GUARDRAIL
 - 6 EXIST. POLYMERIZED BITUMINOUS CONCRETE SURFACE COURSE SUPERPAVE, MIXTURE D, N70 - 2"
 - 7 EXIST. BITUMINOUS CONCRETE SURFACE COURSE CLASS I, TYPE 3, MIXTURE C (LOW ESAL) W/ RUMBLE STRIP
 - 8 PROP. HMA SURFACE COURSE, IL-9.5, MIX "D", N70 - 1½"
 - 9 PROP. HMA BINDER COURSE, IL-9.5, MIX "D", N70 - VARIABLE DEPTH (* DIP CORRECTION)
 - 10 PROP. HMA SHOULDERS - 1½"
 - 11 PROP. AGGREGATE WEDGE SHOULDER, TYPE B
 - 12 PROP. PAVED SHOULDER REMOVAL- VARIABLE DEPTH (SUPERELEVATION CORRECTION)
 - 13 PROP. HMA BASE COURSE, 8" (SUPERELEVATION CORRECTION)

MODEL: Default
 FILE: h:\mfc_p\build\paw_bentley.com\p\w\dot\Documents\DOT_Diff\es\District_6\Project\0672136\CADD\data_S5\0\0\0\sheet\0672136_sht-core.dgn
 PLOT SCALE = 100,0000' / in.
 PLOT DATE = 12/14/2022

USER NAME = Frank.Caraballo	DESIGNED -	REVISED -
DRAWN -	REVISED -	REVISED -
CHECKED -	REVISED -	REVISED -
DATE -	REVISED -	REVISED -

STATE OF ILLINOIS
DEPARTMENT OF TRANSPORTATION

TYPICAL SECTIONS			
SCALE:	SHEET 1	OF 1 SHEETS	STA. TO STA.

F.A.1 RTE.	SECTION	COUNTY	TOTAL SHEETS	SHEET NO.
72, I 72	*	SCOTT	45	10
CONTRACT NO. 72136				
ILLINOIS FED. AID PROJECT				

*(86-B)BDR1,BJR1,BRR1,BP



EXIST. CURVE 462
 PI STA. = 634+78.80
 $\Delta = 20^\circ 55' 55''$ (RT)
 $D = 0^\circ 48' 00''$
 $R = 7,162.53'$
 $T = 1,323.10'$
 $L = 2,616.70'$
 $E = 121.18'$
 $e =$ _____
 T.R. = _____
 S.E. RUN = _____
 P.C. STA. = 621+55.70
 P.T. STA. = 647+72.41

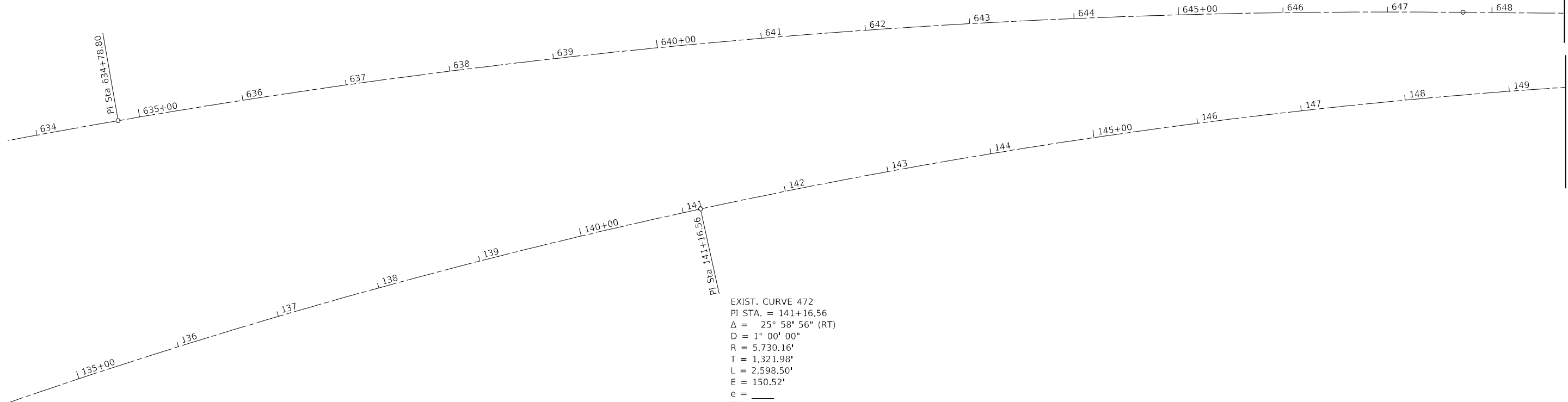

EXIST. CURVE 472
 PI STA. = 141+16.56
 $\Delta = 25^\circ 58' 56''$ (RT)
 $D = 1^\circ 00' 00''$
 $R = 5,730.16'$
 $T = 1,321.98'$
 $L = 2,598.50'$
 $E = 150.52'$
 $e =$ _____
 T.R. = _____
 S.E. RUN = _____
 P.C. STA. = 127+94.58
 P.T. STA. = 153+93.08

Benchmark	NAVD88 Elevation	Description
BM RK-49	442.853	Chsld [] E edge round conc drop inlet foundation cl median I-72 @ sta 64+02.0; 0.8' Lt
BM RK-50	449.198	Chsld [] top NE parapet wall str # 086-0043 WBL I-72 @ sta 46+70.4; 62.1' Lt
BM RK-51	449.317	Chsld [] top NW parapet wall str # 086-0042 EBL I-72 @ sta 44+06.2; 19.9' Rt
BM RK-52	446.55	Chsld [] SW wingwall str # 086-0041 WBL I-72 @ sta 644+62.9; 8.0' Rt
BM RK-53	446.932	Chsld [] NW wingwall str # 086-0040 EBL I-72 @ sta 644+59.9; 101.4' Rt
BM 618+85 N WBL	464.365	Star drill N side E end Valley City Eagle Bridge @ sta 618+85.0; 6.6' Rt
BM 618+85 S WBL	464.363	Star drill at station 618+85 S side E end WBL Valley City Eagle Bridge
BM EBL ABUT N	466.250	Star drill at cl abut N side E end EBL Valley City Eagle Bridge @ sta 118+63.4; 6.9' Rt
BM EBL ABUT S	466.269	Star drill at cl abut S side E end EBL Valley City Eagle Bridge @ sta 118+63.9; 34.6' Rt

MODEL: Default
 FILE NAME: p:\project\paw_bentley.com\p\INDOT\Documents\DOT_offices\Dir\dir_e\Project\0672136\CADDData_S5\0672136\CADDData_S5\0672136\sheet-curve.dgn

USER NAME = Frank.Caraballo	DESIGNED -	REVISED -
PLOT SCALE = 100,0000' / in.	DRAWN -	REVISED -
PLOT DATE = 12/14/2022	CHECKED -	REVISED -
	DATE -	REVISED -

**STATE OF ILLINOIS
DEPARTMENT OF TRANSPORTATION**

ALIGNMENT & ROAD LAYOUT LOCATION

SCALE: SHEET OF SHEETS STA. TO STA.

F.A.I. RTE.	SECTION	COUNTY	TOTAL SHEETS	SHEET NO.
72	(86-8)BDR1,BJR1,BRR1,BP	SCOTT	45	11
CONTRACT NO. 72136				
ILLINOIS FED. AID PROJECT				

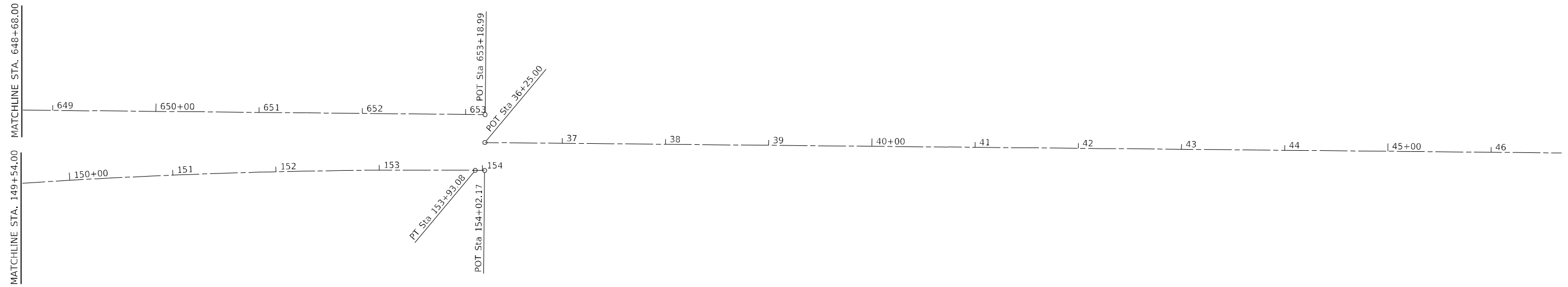

Benchmark	NAVD88 Elevation	Description
BM RK-49	442.853	Chsld [] E edge round conc drop inlet foundation cl median I-72 @ sta 64+02.0; 0.8' Lt
BM RK-50	449.198	Chsld [] top NE parapet wall str # 086-0043 WBL I-72 @ sta 46+70.4; 62.1' Lt
BM RK-51	449.317	Chsld [] top NW parapet wall str # 086-0042 EBL I-72 @ sta 44+06.2; 19.9' Rt
BM RK-52	446.55	Chsld [] SW wingwall str # 086-0041 WBL I-72 @ sta 644+62.9; 8.0' Rt
BM RK-53	446.932	Chsld [] NW wingwall str # 086-0040 EBL I 72 @ sta 644+59.9; 101.4' Rt
BM 618+85 N WBL	464.365	Star drill N side E end Valley City Eagle Bridge @ sta 618+85.0; 6.6' Rt
BM 618+85 S WBL	464.363	Star drill at station 618+85 S side E end WBL Valley City Eagle Bridge
BM EBL ABUT N	466.250	Star drill at cl abut N side E end EBL Valley City Eagle Bridge @ sta 118+63.4; 6.9' Rt
BM EBL ABUT S	466.269	Star drill at cl abut S side E end EBL Valley City Eagle Bridge @ sta 118+63.9; 34.6' Rt

MODEL: Default
 FILE: Mainfile.pxl
 SUBJECT: raw_benchmark.com
 PLOT DATE: 12/14/2022

USER NAME = Frank.Caraballo	DESIGNED -	REVISED -
PLOT SCALE = 100,0000' / in.	DRAWN -	REVISED -
PLOT DATE = 12/14/2022	CHECKED -	REVISED -
	DATE -	REVISED -

**STATE OF ILLINOIS
DEPARTMENT OF TRANSPORTATION**

ALIGNMENT & ROAD LAYOUT LOCATION

SCALE: SHEET OF SHEETS STA. TO STA.

F.A.I. RTE.	SECTION	COUNTY	TOTAL SHEETS	SHEET NO.
72	(86-8)BDR1,BJR1,BRR1,BP	SCOTT	45	12
ILLINOIS FED. AID PROJECT			CONTRACT NO. 72136	

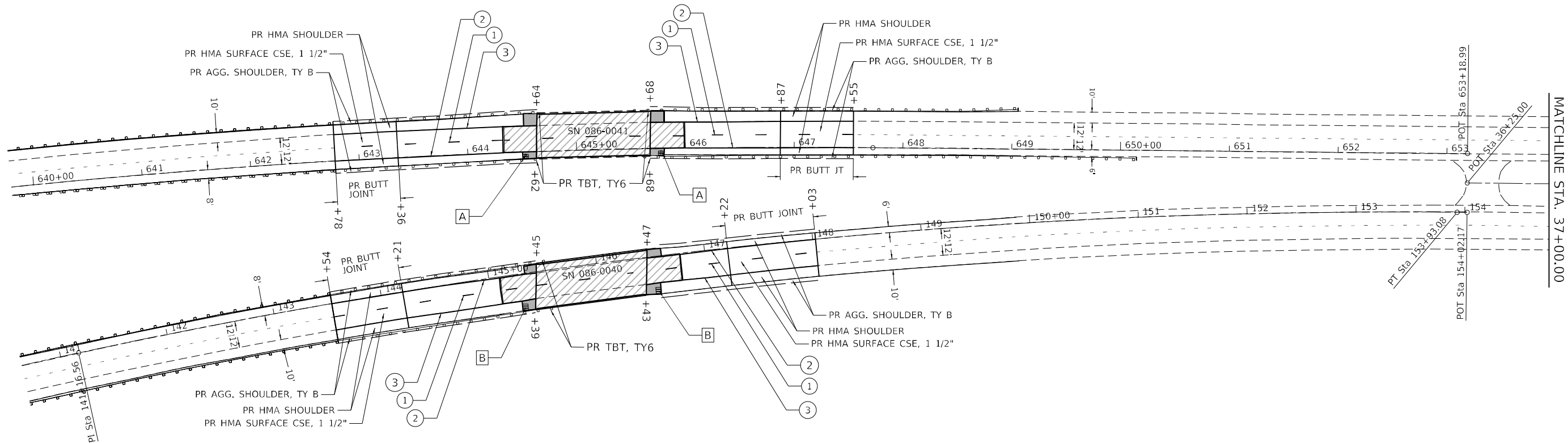

EXIST. CURVE 472
 PI STA. = 141+16.56
 $\Delta = 25^\circ 58' 56''$ (RT)
 $D = 1^\circ 00' 00''$
 $R = 5,730.16'$
 $T = 1,321.98'$
 $L = 2,598.50'$
 $E = 150.52'$
 $e =$
 $T.R. =$
 $S.E. RUN =$
 $P.C. STA. = 127+94.58$
 $P.T. STA. = 153+93.08$

LEGEND

- PR BRIDGE APPROACH REMOVAL & PR PCC SHOULDERS, 8" WITH CONCRETE SHOULDER CURB
- PR HYDROSCARIFICATION WITH MICROSILICA OVERLAY (SEE BRIDGE PLANS)
- PR MODIFIED URETHANE PAVEMENT MARKING, 5" (30' SKIP, 10' DASH) (SOLD WHITE)
- PR MODIFIED URETHANE PAVEMENT MARKING, LINE 5" (SOLID YELLOW)
- PR MODIFIED URETHANE PAVEMENT MARKING, LINE 5" (SOLID WHITE)
- PR TYPE G INLET BOX & REMOVE INLET BOX
- PR TYPE E INLET BOX & REMOVE EX INLET BOX

MODEL: Default
 FILE NAME: p:\projects\paw_bentley.com\p\dot\Documents\DOT_Offices\District_6\Project\0672136\CADD\data_55\0672136\CADD\data_55\0672136\sheet-4b.dwg

USER NAME = Frank.Caraballo	DESIGNED -	REVISED -	
	DRAWN -	REVISED -	
PLOT SCALE = 100,0000' / in.	CHECKED -	REVISED -	
PLOT DATE = 12/14/2022	DATE -	REVISED -	

**STATE OF ILLINOIS
DEPARTMENT OF TRANSPORTATION**

PLAN			
WB /EB I-72			
SCALE:	SHEET	OF	SHEETS
	STA.		TO STA.

F.A.I. RTE.	SECTION	COUNTY	TOTAL SHEETS	SHEET NO.
72	(86-8)BDR1,BJR1,BRR1,BP	SCOTT	45	13
CONTRACT NO. 72136				
ILLINOIS FED. AID PROJECT				

MATCHLINE STA. 37+00.00

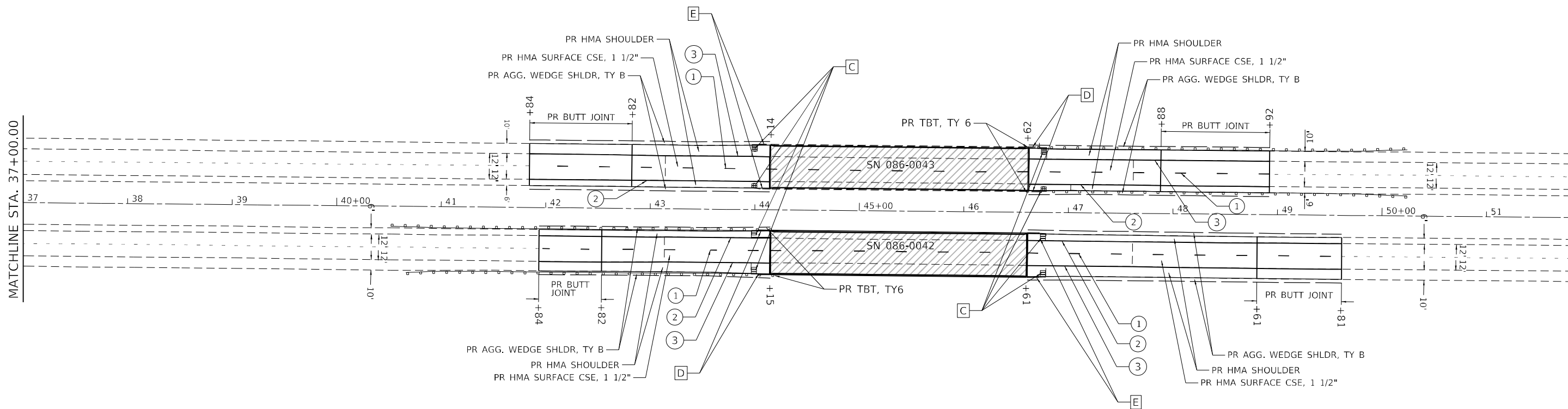

LEGEND

- PR HYDROSCARIFICATION WITH MICROSILICA OVERLAY (SEE BRIDGE PLANS)
- PR MODIFIED URETHANE PAVEMENT MARKING, 5" (30' SKIP, 10' DASH) (SOLID WHITE)
- PR MODIFIED URETHANE PAVEMENT MARKING, LINE 5" (SOLID YELLOW)
- PR MODIFIED URETHANE PAVEMENT MARKING, LINE 5" (SOLID WHITE)
- INLETS TO BE ADJUSTED WITH NEW FRAME & GRATES (SPECIAL)
- PR CONC CURB, TYPE B
- PR CONC. CURB REPAIR

NOTE

* SN 086-0042 AND SN 086-0043: BRIDGE APPROACH PAVEMENTS AND APPROACH SHOULDERS TO BE OVERLAID WITH HMA SURFACE COURSE AND HMA SHOULDER, RESPECTIVELY.

MODEL: Default
 FILE NAME: p:\project-new\beefy.com\p\w\DOT\Documents\DOT_Offices\District_6\Project\0672136\CADD\data_55\0672136\CADD\data_55\0672136-sheet-4-ba.dgn

USER NAME = Frank.Caraballo	DESIGNED -	REVISED -
	DRAWN -	REVISED -
PLOT SCALE = 100,0000' / in.	CHECKED -	REVISED -
PLOT DATE = 12/14/2022	DATE -	REVISED -

**STATE OF ILLINOIS
DEPARTMENT OF TRANSPORTATION**

PLAN			
WB /EB I-72			
SCALE:	SHEET	OF	SHEETS
	STA.	TO	STA.

F.A.I. RTE.	SECTION	COUNTY	TOTAL SHEETS	SHEET NO.
72	(86-8)BDR1,BJR1,BRR1,BP	SCOTT	45	14
CONTRACT NO. 72136				
ILLINOIS FED. AID PROJECT				

TRAFFIC CONTROL PRE-STAGE I

1. REMOVE AND REPLACE SHOULDER FOR STAGE I AND STAGE II TRAFFIC USING STANDARD 701400 & 701401.
* SEE SHOULDER SUPERELEVATION TRANSITION DETAIL
2. HIGHWAY STANDARDS USED:
- 701400
- 701401

TRAFFIC CONTROL STAGE I

1. INSTALL TRAFFIC CONTROL FOR STAGE I AND SHIFT TRAFFIC AS SHOWN AND USING THE APPLICABLE PORTIONS OF THE HIGHWAY STANDARDS USED.
2. HIGHWAY STANDARDS USED:
- 701400
- 701402 (SPECIAL)
3. TRAFFIC CONTROL DETAILS (SIGNS, PAVEMENT MARKINGS, ETC) NOT SHOWN IN THESE STAGE CONSTRUCTION DETAILS SHALL BE AS PER THE HIGHWAY STANDARDS LISTED IN NOTE #2.

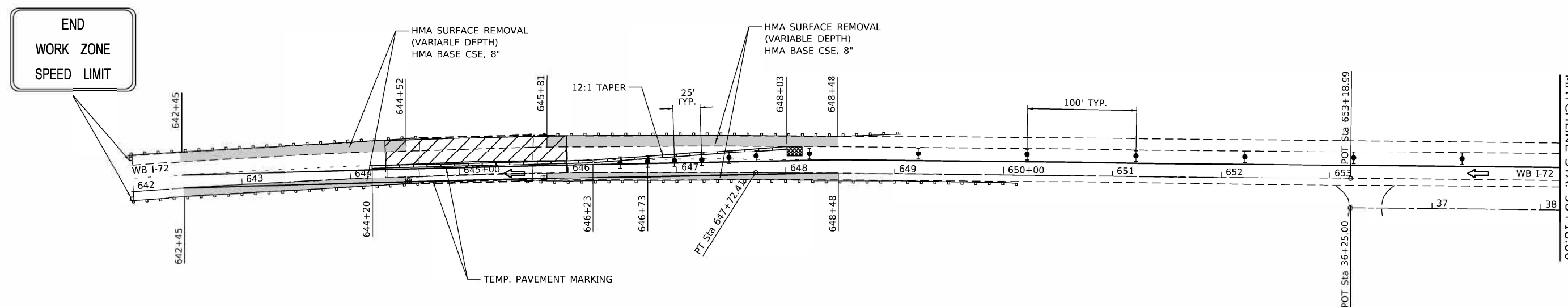

- ARROW BOARD
- TRAFFIC FLOW ARROW
- FULL DEPTH SHOULDER RECONSTRUCTION FOR STAGE TRAFFIC (PRE-STAGE I)
- WORK AREA
- SIGN
- DIRECTION INDICATOR BARRICADE WITH STEADY BURN MONODIRECTIONAL LIGHT
- TYPE II BARRICADE, DRUM, OR VERTICAL BARRICADE WITH STEADY BURN MONODIRECTIONAL LIGHT
- TEMPORARY IMPACT ATTENUATOR
- TEMPORARY CONCRETE BARRIER

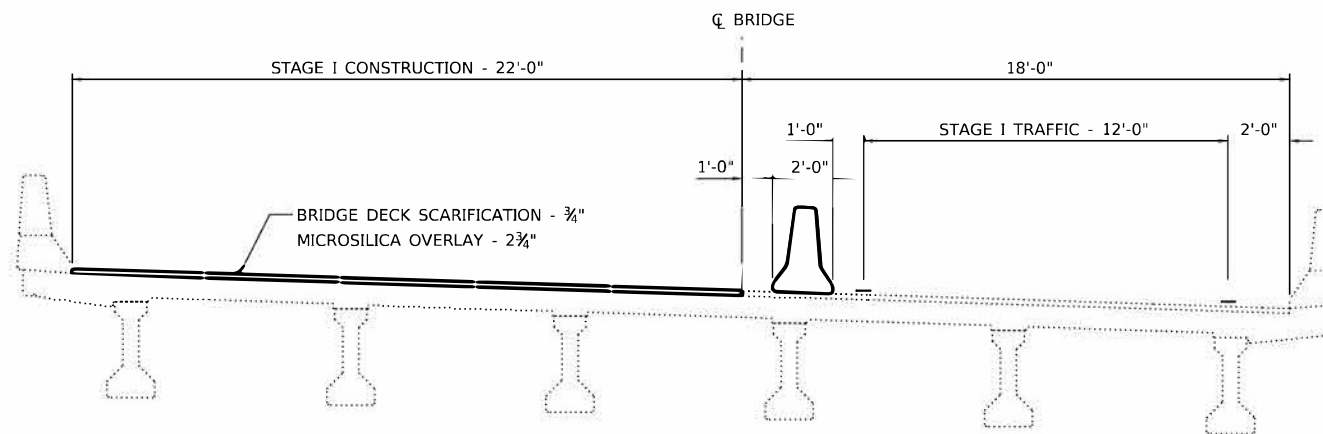

STAGE I - SN 086-0041
(LOOKING EAST)

MODEL: Default
 FILE: Main: p:\illicit-pw-bentley.com\pwwdott\documents\DOT Office\District 8\Project\0872136\CADD\Draw 5510\CADD\sheet\0872136-01-StageI.dgn

USER NAME = Frank.Caraballo	DESIGNED -	REVISED -
DRAWN -	REVISIONS -	
PLOT SCALE = 100.0000" / in.	CHECKED -	REVISED +
PLOT DATE = 12/14/2022	DATE -	REVISED -

**STATE OF ILLINOIS
DEPARTMENT OF TRANSPORTATION**

**STAGE I - WB I-72
SN 086-0041**

SCALE: SHEET 1 OF 12 SHEETS STA. TO STA.

F.A.I. RTE.	SECTION	COUNTY	TOTAL SHEETS	SHEET NO.
72	(86-8)BDR1,BR1,BRR1,BP	SCOTT	45	15
				CONTRACT NO. 72136
ILLINOIS FED. AID PROJECT				

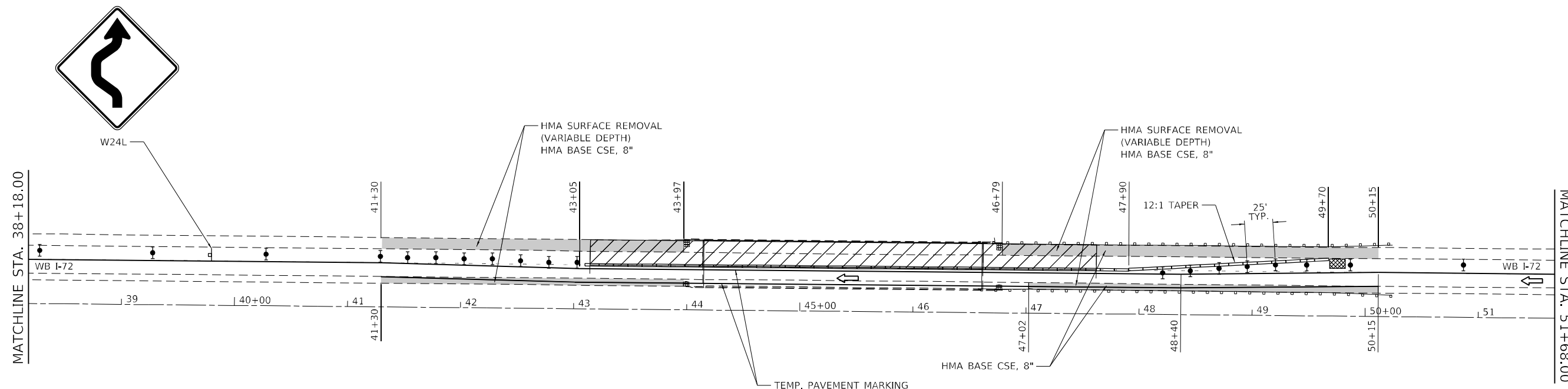

- ARROW BOARD
- TRAFFIC FLOW ARROW
- FULL DEPTH SHOULDER RECONSTRUCTION FOR STAGE TRAFFIC (PRE-STAGE I)
- WORK AREA
- SIGN
- DIRECTION INDICATOR BARRICADE WITH STEADY BURN MONODIRECTIONAL LIGHT
- TYPE II BARRICADE, DRUM, OR VERTICAL BARRICADE WITH STEADY BURN MONODIRECTIONAL LIGHT
- TEMPORARY IMPACT ATTENUATOR
- TEMPORARY CONCRETE BARRIER

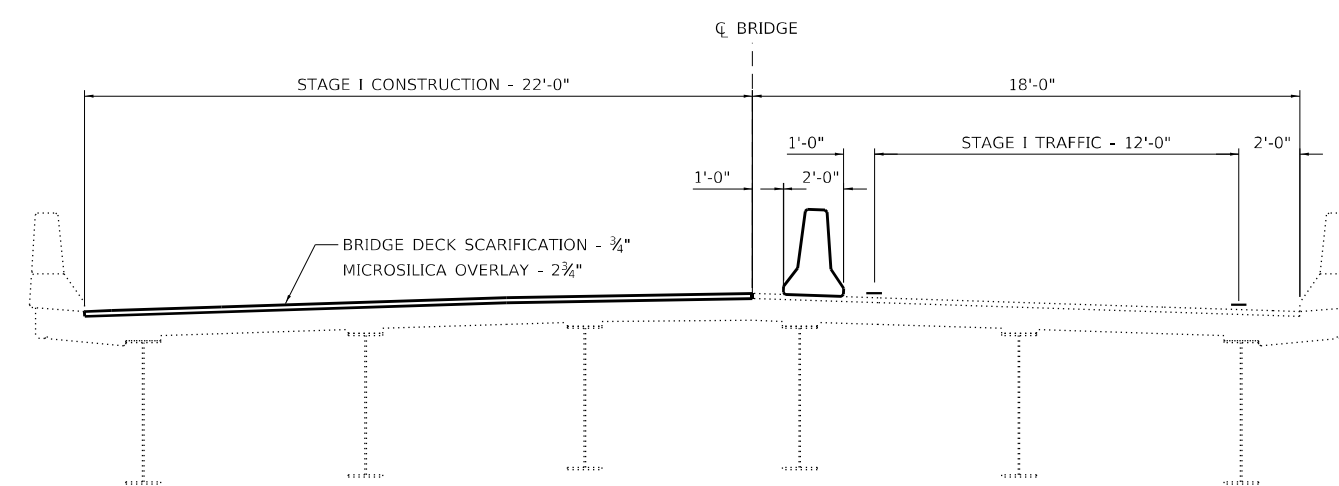

STAGE II - SN 086-0043
(LOOKING EAST)

MODEL: Default
 FILE: Mainfile.pxl
 SUBJECT: new_benefit.com
 P:\V\DOT\Documents\DOT_Offices\District_6\Project\0672136\CADD\data_S5\0672136\Sheet\StageI.dgn







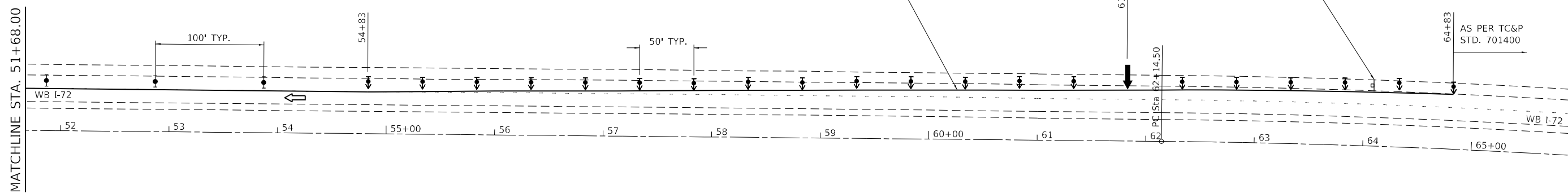

USER NAME = Frank.Caraballo	DESIGNED -	REVISED -
PLOT SCALE = 100,0000' / in.	DRAWN -	REVISED -
PLOT DATE = 12/14/2022	CHECKED -	REVISED -
	DATE -	REVISED -

**STATE OF ILLINOIS
DEPARTMENT OF TRANSPORTATION**

STAGE I - WB I-72 SN 086-0043			
SCALE:	SHEET 2	OF 12 SHEETS	STA. TO STA.

F.A.I. RTE.	SECTION	COUNTY	TOTAL SHEETS	SHEET NO.
72	(86-8)BDR1,BJR1,BRR1,BP	SCOTT	45	16
CONTRACT NO. 72136				
ILLINOIS FED. AID PROJECT				



-  ARROW BOARD
-  TRAFFIC FLOW ARROW
-  FULL DEPTH SHOULDER RECONSTRUCTION FOR STAGE TRAFFIC (PRE-STAGE I)
-  WORK AREA
-  SIGN
-  DIRECTION INDICATOR BARRICADE WITH STEADY BURN MONODIRECTIONAL LIGHT
-  TYPE II BARRICADE, DRUM, OR VERTICAL BARRICADE WITH STEADY BURN MONODIRECTIONAL LIGHT
-  TEMPORARY IMPACT ATTENUATOR
-  TEMPORARY CONCRETE BARRIER

MODEL: Default
 FILE: Mainfile.pwd
 SUBJECT: new_bentley.com
 PLOT: PLOT Documents\DOT Office\District 6\Project\0672136\CADD\data_S5\0\CADD\sheet0672136_sht3.dgn

USER NAME = Frank.Caraballo	DESIGNED -	REVISED -
PLOT SCALE = 100,0000' / in.	DRAWN -	REVISED -
PLOT DATE = 12/14/2022	CHECKED -	REVISED -
	DATE -	REVISED -







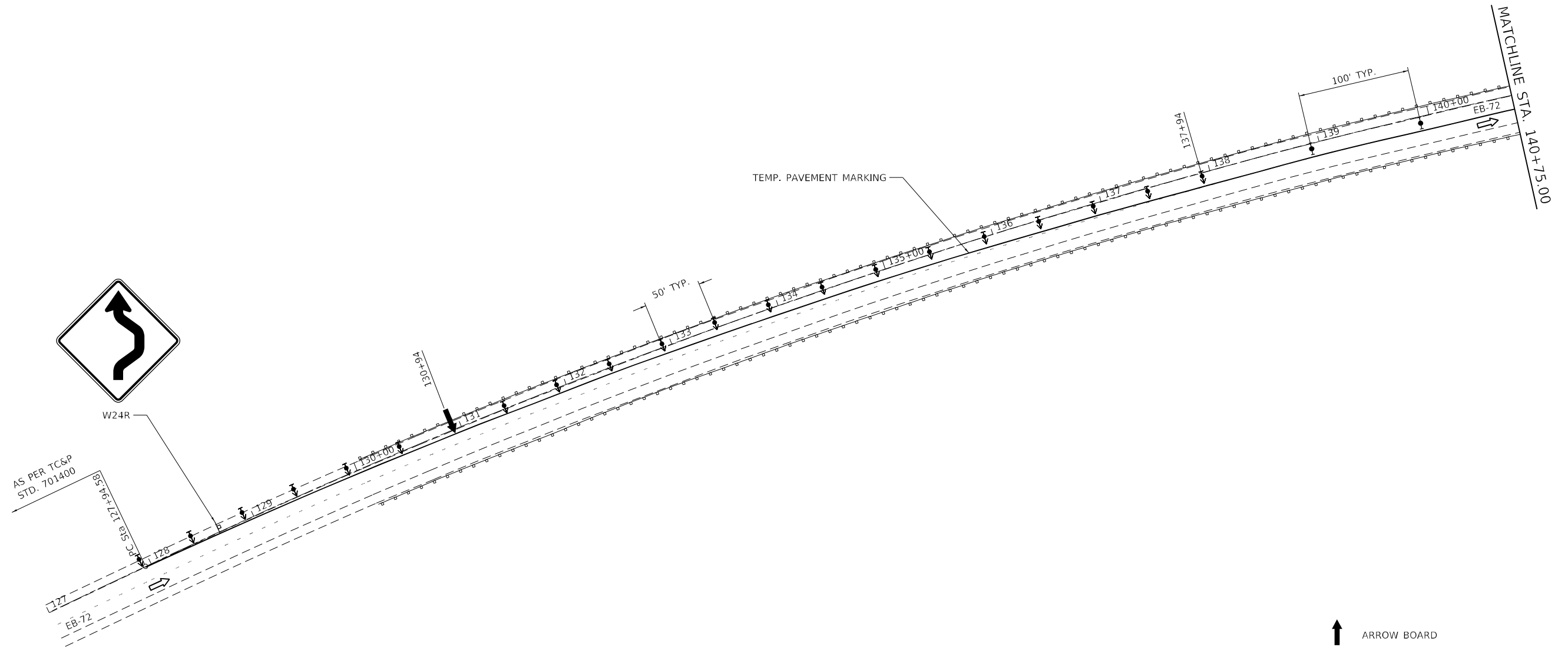

**STATE OF ILLINOIS
DEPARTMENT OF TRANSPORTATION**

STAGE I - WB I-72

SCALE: SHEET 3 OF 12 SHEETS STA. TO STA.

F.A.I. RTE.	SECTION	COUNTY	TOTAL SHEETS	SHEET NO.
72	(86-8)BDR1,BJR1,BRR1,BP	SCOTT	45	17
CONTRACT NO. 72136				
ILLINOIS FED. AID PROJECT				



-  ARROW BOARD
-  TRAFFIC FLOW ARROW
-  FULL DEPTH SHOULDER RECONSTRUCTION (PRE-STAGE I)
-  WORK AREA
-  SIGN
-  DIRECTION INDICATOR BARRICADE WITH STEADY BURN MONODIRECTIONAL LIGHT
-  TYPE II BARRICADE, DRUM, OR VERTICAL BARRICADE WITH STEADY BURN MONODIRECTIONAL LIGHT
-  TEMPORARY IMPACT ATTENUATOR
-  TEMPORARY CONCRETE BARRIER

MODEL: Default
 FILE: Mainfile.pxl
 SUBJECT: ew.bea@fy.com
 P:\V\DOT\Documents\DOT_offices\District_6\Project\0672136\CADD\data_55\0\CADD\sheet\0672136-eh-Stage1.dgn

USER NAME = Frank.Caraballo	DESIGNED -	REVISED -
	DRAWN -	REVISED -
PLOT SCALE = 100,0000' / in.	CHECKED -	REVISED -
PLOT DATE = 12/14/2022	DATE -	REVISED -

**STATE OF ILLINOIS
DEPARTMENT OF TRANSPORTATION**

STAGE I - EB I-72

SCALE: SHEET 4 OF 12 SHEETS STA. TO STA.

F.A.I. RTE.	SECTION	COUNTY	TOTAL SHEETS	SHEET NO.
72	(86-8)BDR1,BJR1,BRR1,BP	SCOTT	45	18
CONTRACT NO. 72136				
ILLINOIS		FED. AID PROJECT		

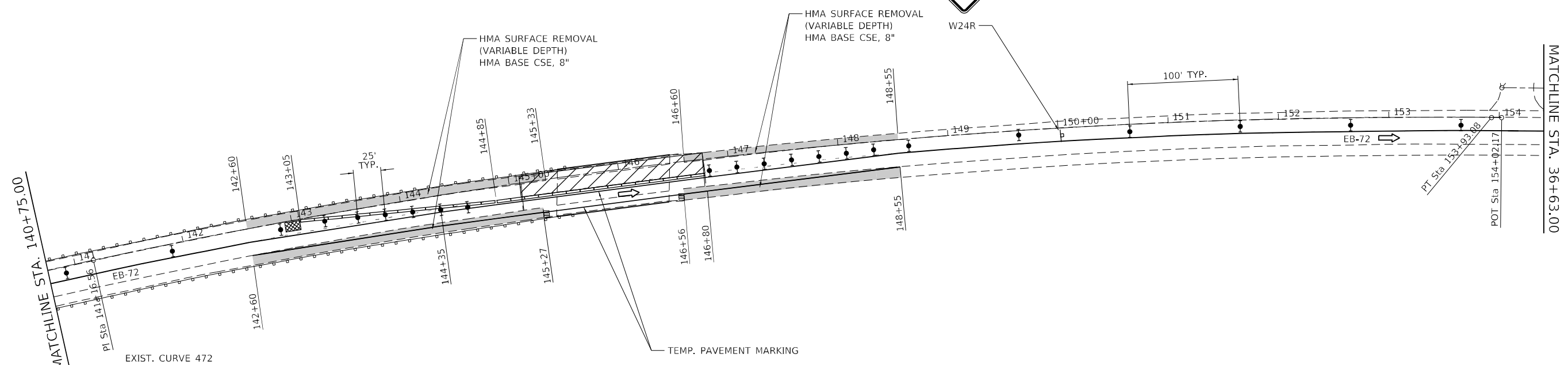
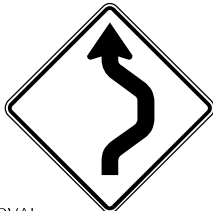

EXIST. CURVE 472
 PI STA. = 141+16.56
 $\Delta = 25^\circ 58' 56''$ (RT)
 $D = 1^\circ 00' 00''$
 $R = 5,730.16'$
 $T = 1,321.98'$
 $L = 2,598.50'$
 $E = 150.52'$
 $e = \text{---}$
 $T.R. = \text{---}$
 $S.E. RUN = \text{---}$
 $P.C. STA. = 127+94.58$
 $P.T. STA. = 153+93.08$

- ARROW BOARD
- TRAFFIC FLOW ARROW
- FULL DEPTH SHOULDER RECONSTRUCTION (PRE-STAGE I)
- WORK AREA
- SIGN
- DIRECTION INDICATOR BARRICADE WITH STEADY BURN MONODIRECTIONAL LIGHT
- TYPE II BARRICADE, DRUM, OR VERTICAL BARRICADE WITH STEADY BURN MONODIRECTIONAL LIGHT
- TEMPORARY IMPACT ATTENUATOR
- TEMPORARY CONCRETE BARRIER

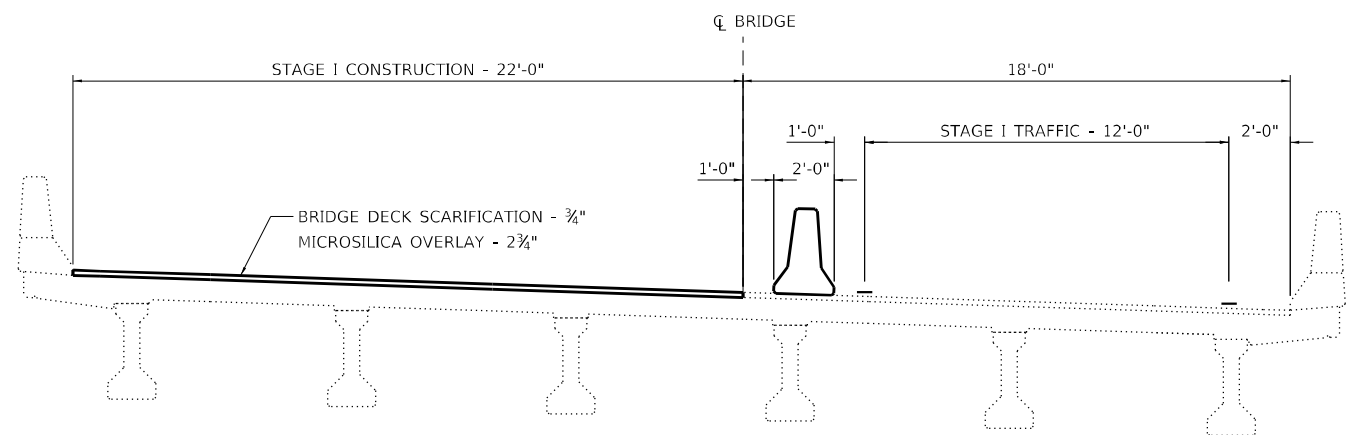

STAGE I - SN 086-0040
 (LOOKING EAST)

MODEL: Default
 FILE: Mainfile.pxl
 PROJECT: D:\Projects\DOT\Office\District 6\Projects\0672136\CADD\data_S5\0672136\CADD\sheet\0672136-sh-5.dgn

USER NAME = Frank,Caraballo	DESIGNED -	REVISED -
PLOT SCALE = 100,0000' / in.	DRAWN -	REVISED -
PLOT DATE = 12/14/2022	CHECKED -	REVISED -
	DATE -	REVISED -

STATE OF ILLINOIS
DEPARTMENT OF TRANSPORTATION

STAGE I - EB I-72			
SN 086-0040			
SCALE:	SHEET 5	OF 12 SHEETS	STA. TO STA.

F.A.I. RTE.	SECTION	COUNTY	TOTAL SHEETS	SHEET NO.
72	(86-8)BDR1,BUR1,BRR1,BP	SCOTT	45	19
CONTRACT NO. 72136				
ILLINOIS FED. AID PROJECT				



END
WORK ZONE
SPEED LIMIT

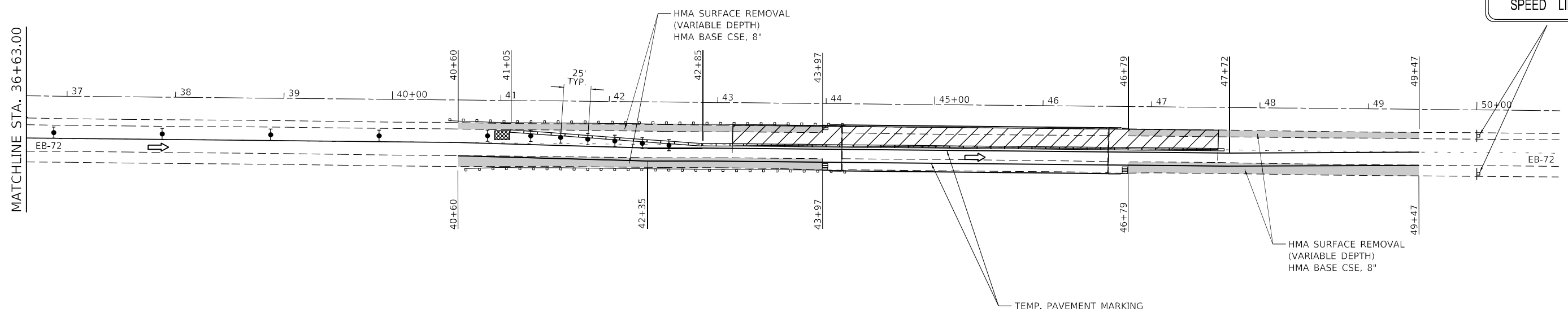

- ARROW BOARD
- TRAFFIC FLOW ARROW
- FULL DEPTH SHOULDER RECONSTRUCTION (PRE-STAGE I)
- WORK AREA
- SIGN
- DIRECTION INDICATOR BARRICADE WITH STEADY BURN MONODIRECTIONAL LIGHT
- TYPE II BARRICADE, DRUM, OR VERTICAL BARRICADE WITH STEADY BURN MONODIRECTIONAL LIGHT
- TEMPORARY IMPACT ATTENUATOR
- TEMPORARY CONCRETE BARRIER

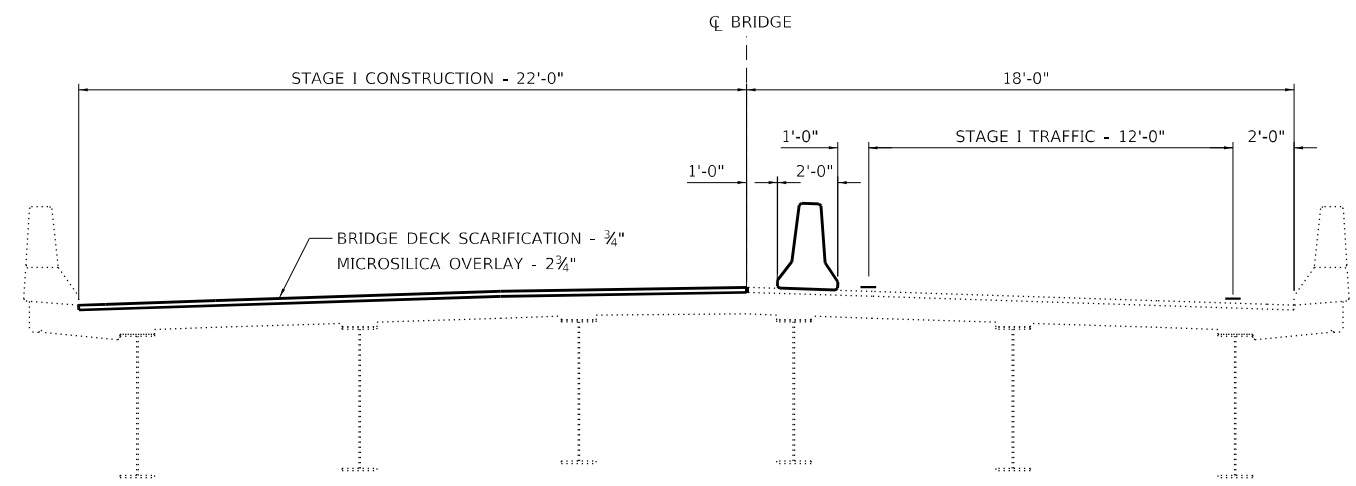

STAGE I - SN 086-0042
(LOOKING EAST)

MODEL: Default
 FILE: Mainfile.pxl
 SUBJECT: pw_bentley.com
 PLOT DATE: 12/14/2022
 PROJECT: I:\DOT\Documents\DOT Office\District 6\Projects\0672136\CADD\data_S5\0672136\EB-72\Stage1.dgn

USER NAME = Frank.Caraballo	DESIGNED -	REVISED -
	DRAWN -	REVISED -
PLOT SCALE = 100,0000' / in.	CHECKED -	REVISED -
PLOT DATE = 12/14/2022	DATE -	REVISED -

**STATE OF ILLINOIS
DEPARTMENT OF TRANSPORTATION**

STAGE I - EB I-72 SN 086-0042			
SCALE:	SHEET 6	OF 12 SHEETS	STA. TO STA.

F.A.I. RTE.	SECTION	COUNTY	TOTAL SHEETS	SHEET NO.
72	(86-8)BDR1,BJR1,BRR1,BP	SCOTT	45	20
CONTRACT NO. 72136				
ILLINOIS FED. AID PROJECT				

TRAFFIC CONTROL STAGE II

1. RELOCATE TRAFFIC CONTROL FOR STAGE II AND SHIFT TRAFFIC AS SHOWN AND USING THE APPLICABLE PORTION OF THE HIGHWAY STANDARDS USED.
2. HIGHWAY STANDARDS USED:
 - 701400
 - 701402 (SPECIAL)
3. TRAFFIC CONTROL DETAILS (SIGNS, PAVEMENT MARKINGS, ETC) NOT SHOWN IN THESE STAGE CONSTRUCTION DETAILS SHALL BE AS PER HIGHWAY STANDARDS LISTED IN NOTE #2.

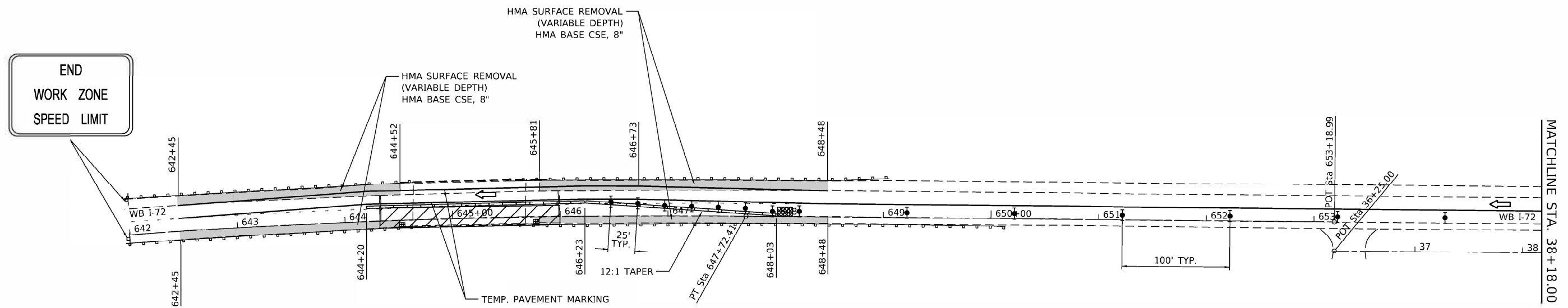

- ARROW BOARD
- TRAFFIC FLOW ARROW
- FULL DEPTH SHOULDER RECONSTRUCTION (PRE-STAGE I)
- WORK AREA
- SIGN
- DIRECTION INDICATOR BARRICADE WITH STEADY BURN MONODIRECTIONAL LIGHT
- TYPE II BARRICADE, DRUM, OR VERTICAL BARRICADE WITH STEADY BURN MONODIRECTIONAL LIGHT
- TEMPORARY IMPACT ATTENUATOR
- TEMPORARY CONCRETE BARRIER

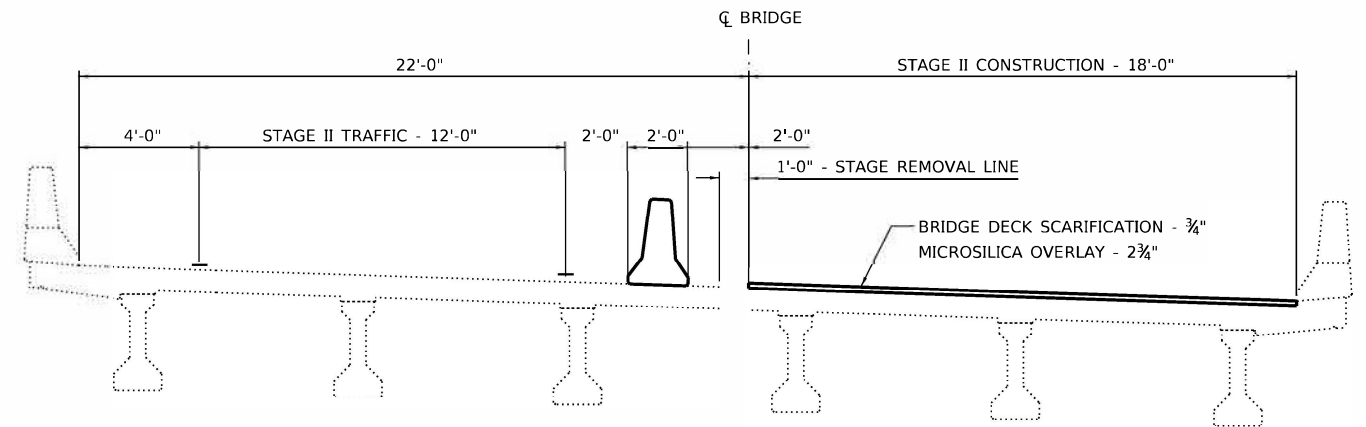

MODEL: Default
 FILE: Main: p:\1115042-pw-bentley.com\p1115042\Documents\DOT_Offices\District_8\Projects\0872136\CADD\Draw_55108\CADDsheets\0872136-sht-72136.dgn

USER NAME = Frank.Caraballo	DESIGNED -	REVISED -
DRAWN -	REVISIONS -	
PLOT SCALE = 100.0000" / in.	CHECKED -	REVISED -
PLOT DATE = 12/14/2022	DATE -	REVISED -







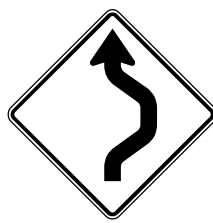
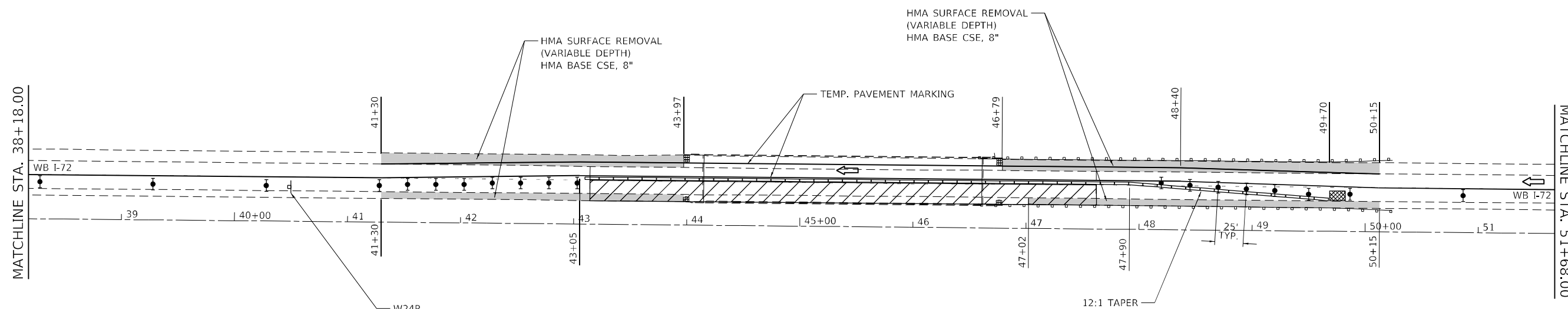

**STATE OF ILLINOIS
DEPARTMENT OF TRANSPORTATION**

**STAGE II - WB I-72
SN 086-0041**

SCALE: SHEET 7 OF 12 SHEETS STA. TO STA.

F.A.I. RTE.	SECTION	COUNTY	TOTAL SHEETS	SHEET NO.
72	(86-8)BDR1,BJR1,BRR1,BP	SCOTT	45	21
CONTRACT NO. 72136			ILLINOIS FED. AID PROJECT	



-  ARROW BOARD
-  TRAFFIC FLOW ARROW
-  FULL DEPTH SHOULDER RECONSTRUCTION (PRE-STAGE I)
-  WORK AREA
-  SIGN
-  DIRECTION INDICATOR BARRICADE WITH STEADY BURN MONODIRECTIONAL LIGHT
-  TYPE II BARRICADE, DRUM, OR VERTICAL BARRICADE WITH STEADY BURN MONODIRECTIONAL LIGHT
-  TEMPORARY IMPACT ATTENUATOR
-  TEMPORARY CONCRETE BARRIER

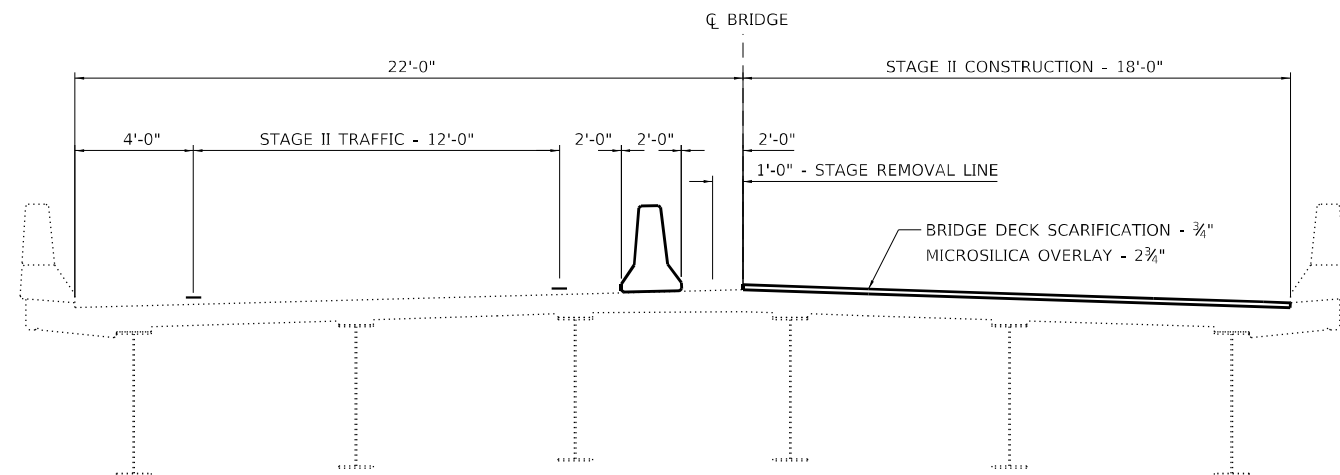

STAGE II - SN 086-0043
(LOOKING EAST)

MODEL: Default
 FILE: Mainfile.pxl
 SUBJECT: new_benefit.com
 PLOT DATE: 12/14/2022
 PROJECT: I:\DOT\Documents\DOT_Offices\District_6\Projects\08672136\CADD\data_S5\086000\sheet0672136_sht5.dgn







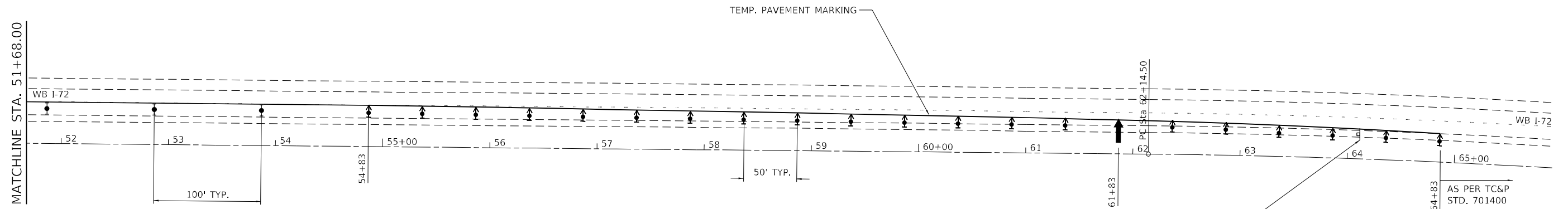

USER NAME = Frank.Caraballo	DESIGNED -	REVISED -
PLOT SCALE = 100,0000' / in.	DRAWN -	REVISIED -
PLOT DATE = 12/14/2022	CHECKED -	REVISIED -
	DATE -	REVISIED -

**STATE OF ILLINOIS
DEPARTMENT OF TRANSPORTATION**

STAGE II - WB I-72 SN 086-0043			
SCALE:	SHEET 8	OF 12 SHEETS	STA. TO STA.

F.A.I. RTE.	SECTION	COUNTY	TOTAL SHEETS	SHEET NO.
72	(86-8)BDR1,BJR1,BRR1,BP	SCOTT	45	22
CONTRACT NO. 72136				
ILLINOIS FED. AID PROJECT				



-  ARROW BOARD
-  TRAFFIC FLOW ARROW
-  FULL DEPTH SHOULDER RECONSTRUCTION (PRE-STAGE I)
-  WORK AREA
-  SIGN
-  DIRECTION INDICATOR BARRICADE WITH STEADY BURN MONODIRECTIONAL LIGHT
-  TYPE II BARRICADE, DRUM, OR VERTICAL BARRICADE WITH STEADY BURN MONODIRECTIONAL LIGHT
-  TEMPORARY IMPACT ATTENUATOR
-  TEMPORARY CONCRETE BARRIER

MODEL: Default
 FILE: \\na16c-pw-bentley.com\P\DOT\Documents\DOT_Offices\District_6\Project\0672136\CADD\data_S5\0\CADD\sheet\0672136-shs-Stationing.dgn







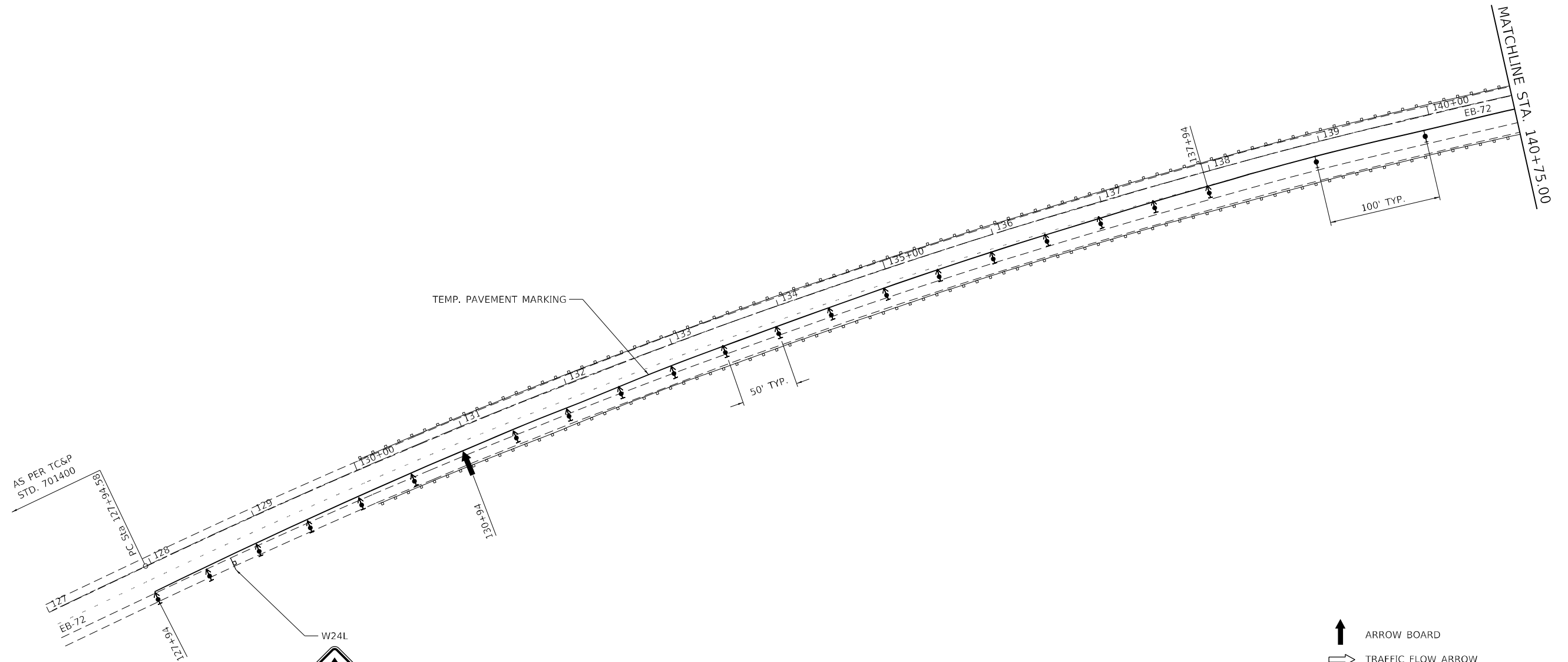

USER NAME = Frank.Caraballo	DESIGNED -	REVISED -
	DRAWN -	REVISED -
PLOT SCALE = 100,0000' / in.	CHECKED -	REVISED -
PLOT DATE = 12/14/2022	DATE -	REVISED -

**STATE OF ILLINOIS
DEPARTMENT OF TRANSPORTATION**

STAGE II - WB I-72			
SCALE:	SHEET 9	OF 12 SHEETS	STA. TO STA.

F.A.I. RTE.	SECTION	COUNTY	TOTAL SHEETS	SHEET NO.
72	(86-8)BDR1,BJR1,BRR1,BP	SCOTT	45	23
CONTRACT NO. 72136				
ILLINOIS FED. AID PROJECT				



-  ARROW BOARD
-  TRAFFIC FLOW ARROW
-  FULL DEPTH SHOULDER RECONSTRUCTION (PRE-STAGE I)
-  WORK AREA
-  SIGN
-  DIRECTION INDICATOR BARRICADE WITH STEADY BURN MONODIRECTIONAL LIGHT
-  TYPE II BARRICADE, DRUM, OR VERTICAL BARRICADE WITH STEADY BURN MONODIRECTIONAL LIGHT
-  TEMPORARY IMPACT ATTENUATOR
-  TEMPORARY CONCRETE BARRIER

MODEL: Default
 FILE NAME: p:\ultra-cad\benefit.com\p\illdot\Documents\DOT_offices\District_6\Project\0672136\CADD\data_55\0672136\EB-72\136-eh-Stage10.dgn

USER NAME = Frank.Caraballo	DESIGNED -	REVISED -
PLOT SCALE = 100,0000' / in.	DRAWN -	REVISIED -
PLOT DATE = 12/14/2022	CHECKED -	REVISIED -
	DATE -	REVISIED -

**STATE OF ILLINOIS
DEPARTMENT OF TRANSPORTATION**

STAGE II - EB I-72

SCALE: SHEET 10 OF 12 SHEETS STA. TO STA.

F.A.I. RTE.	SECTION	COUNTY	TOTAL SHEETS	SHEET NO.
72	(86-8)BDR1,BJR1,BRR1,BP	SCOTT	45	24
CONTRACT NO. 72136				
ILLINOIS FED. AID PROJECT				

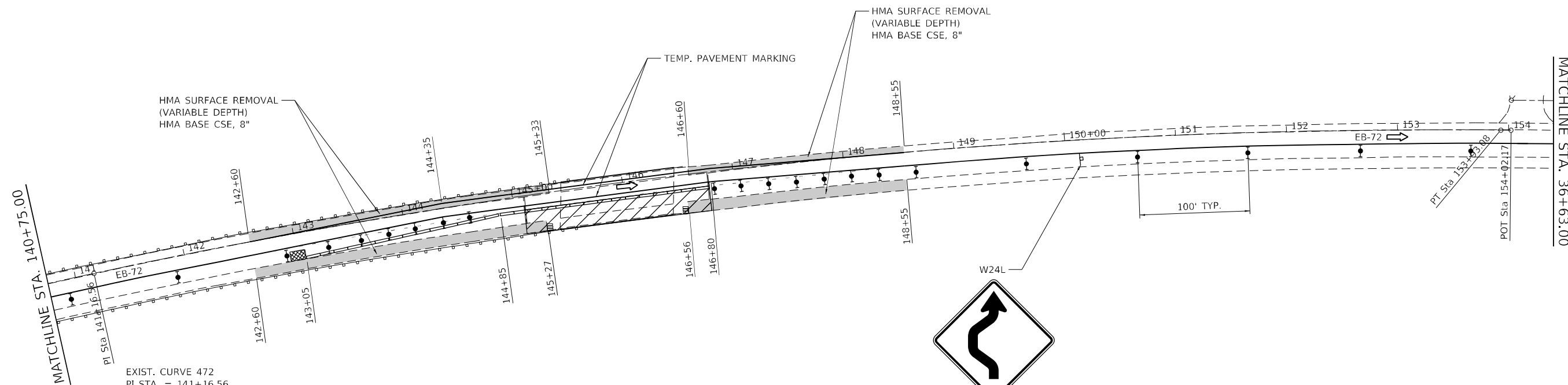

EXIST. CURVE 472
 PI STA. = 141+16.56
 $\Delta = 25^\circ 58' 56''$ (RT)
 $D = 1^\circ 00' 00''$
 $R = 5,730.16'$
 $T = 1,321.98'$
 $L = 2,598.50'$
 $E = 150.52'$
 $e = \text{---}$
 $T.R. = \text{---}$
 $S.E. RUN = \text{---}$
 $P.C. STA. = 127+94.58$
 $P.T. STA. = 153+93.08$

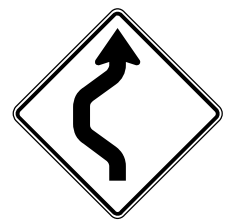

- ARROW BOARD
- TRAFFIC FLOW ARROW
- FULL DEPTH SHOULDER RECONSTRUCTION (PRE-STAGE I)
- WORK AREA
- SIGN
- DIRECTION INDICATOR BARRICADE WITH STEADY BURN MONODIRECTIONAL LIGHT
- TYPE II BARRICADE, DRUM, OR VERTICAL BARRICADE WITH STEADY BURN MONODIRECTIONAL LIGHT
- TEMPORARY IMPACT ATTENUATOR
- TEMPORARY CONCRETE BARRIER

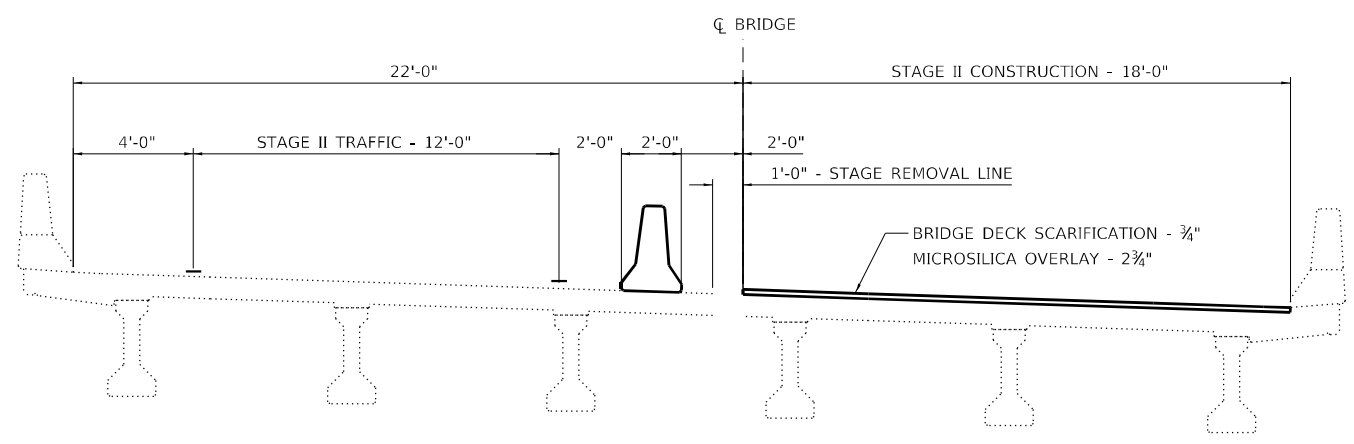

STAGE II - SN 086-0040
 (LOOKING EAST)

MODEL: Default
 FILE: Mainfile.pxl
 SUBJECT: raw_benefit.com
 P:\V\DOT\Documents\DOT_Offices\District_6\Projects\0672136\CADD\data_S5\0672136\Sheet-StageIIa.dgn

USER NAME = Frank,Caraballo	DESIGNED -	REVISED -
PLOT SCALE = 100,0000' / in.	DRAWN -	REVISED -
PLOT DATE = 12/14/2022	CHECKED -	REVISED -
	DATE -	REVISED -

**STATE OF ILLINOIS
 DEPARTMENT OF TRANSPORTATION**







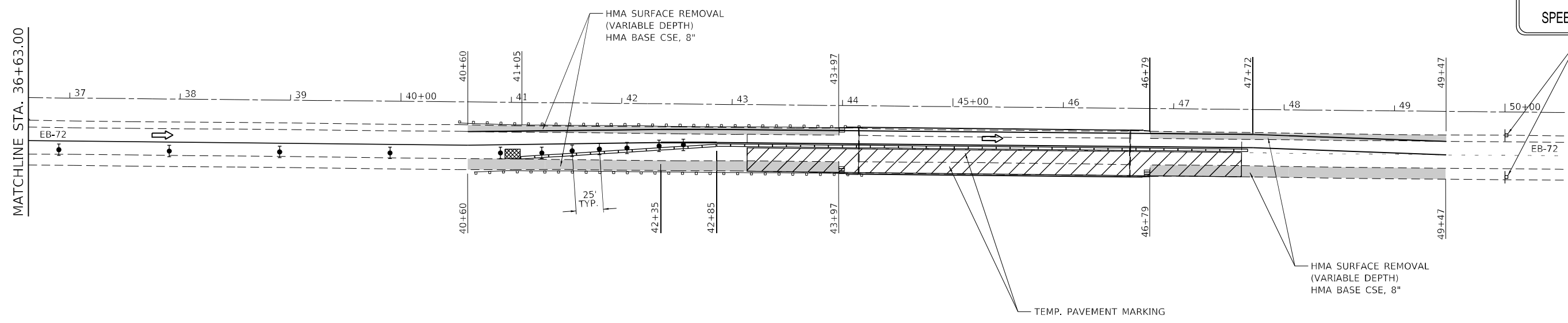

STAGE II - EB I-72 SN 086-0040			
SCALE:	SHEET 11	OF 12 SHEETS	STA. TO STA.

F.A.I. RTE.	SECTION	COUNTY	TOTAL SHEETS	SHEET NO.
72	(86-8)BDR1,BR1,BRR1,BP	SCOTT	45	25
CONTRACT NO. 72136				
ILLINOIS FED. AID PROJECT				



END
WORK ZONE
SPEED LIMIT



-  ARROW BOARD
-  TRAFFIC FLOW ARROW
-  FULL DEPTH SHOULDER RECONSTRUCTION (PRE-STAGE I)
-  WORK AREA
-  SIGN
-  DIRECTION INDICATOR BARRICADE WITH STEADY BURN MONODIRECTIONAL LIGHT
-  TYPE II BARRICADE, DRUM, OR VERTICAL BARRICADE WITH STEADY BURN MONODIRECTIONAL LIGHT
-  TEMPORARY IMPACT ATTENUATOR
-  TEMPORARY CONCRETE BARRIER

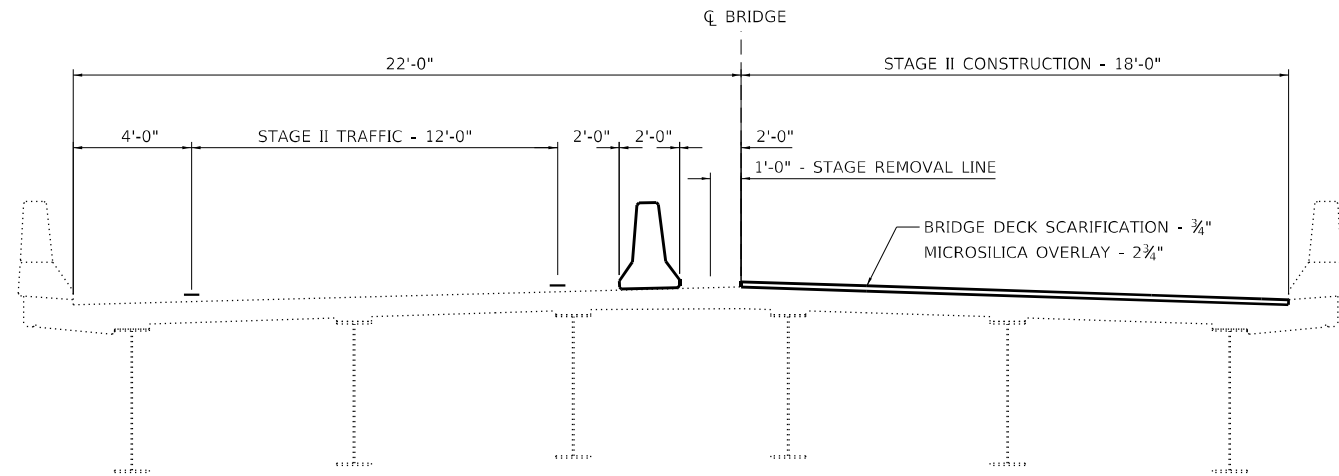

STAGE II - SN 086-0042
(LOOKING EAST)

MODEL: Default
 FILE: Mainfile.pxl
 SUBJECT: ew_bentley.com/PLM/IDOT/Documents/IDOT_Offices/District_E/Projects/0672136/CADD/data_S5/0672136-ehs-Stage10.dgn

USER NAME = Frank.Caraballo	DESIGNED -	REVISED -
DRAWN -	REVISOR -	
PLOT SCALE = 100,0000' / in.	CHECKED -	REVISOR -
PLOT DATE = 12/14/2022	DATE -	REVISOR -

**STATE OF ILLINOIS
DEPARTMENT OF TRANSPORTATION**

**STAGE II - EB I-72
SN 086-0042**

SCALE: SHEET 12 OF 12 SHEETS STA. TO STA.

F.A.I. RTE.	SECTION	COUNTY	TOTAL SHEETS	SHEET NO.
72	(86-8)BDR1,BR1,BRR1,BP	SCOTT	45	26
CONTRACT NO. 72136				
ILLINOIS FED. AID PROJECT				

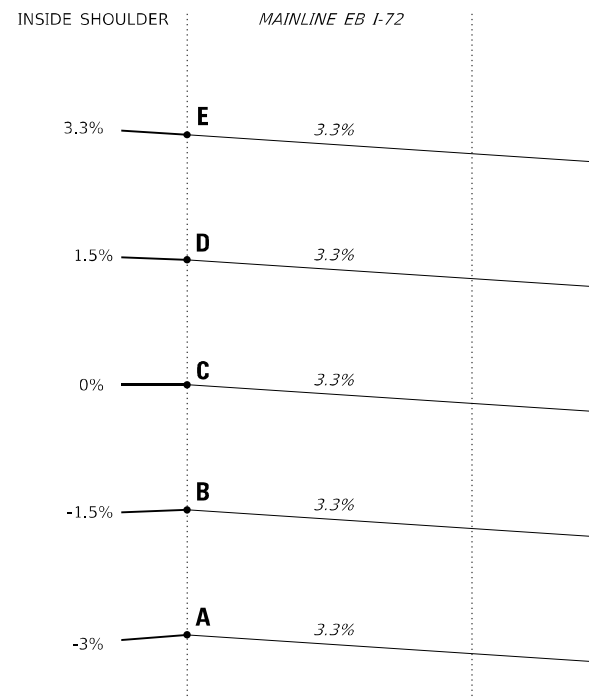

SHOULDER SUPERELEVATION TRANSITION
SN 086-0040

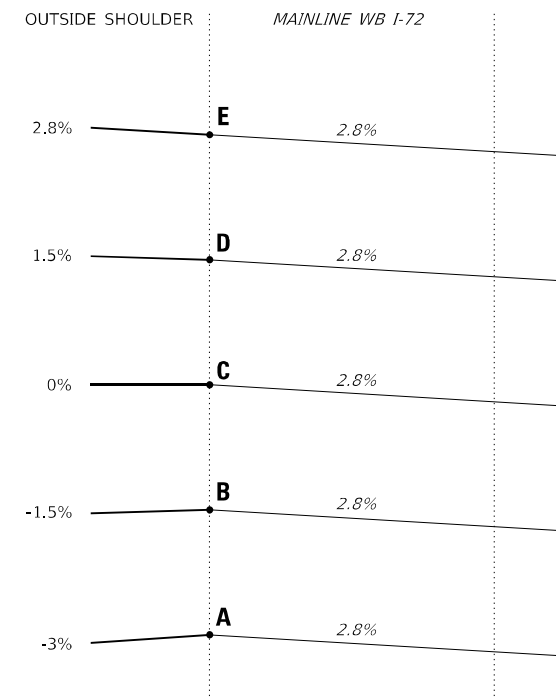

SHOULDER SUPERELEVATION TRANSITION
SN 086-0041

SHOULDER SUPERELEVATION CORRECTION						
LOCATION	e	A	B	C	D	E
SN 086-0040 (WEST)	3.3%	STA 143+54.00	STA 143+91.00	STA 144+28.00	STA 144+65.00	STA 145+09.00
SN 086-0040 (EAST)	3.3%	STA 148+02.00	STA 147+72.00	STA 147+42.00	STA 147+12.00	STA 146+77.00
SN 086-0041 (WEST)	2.8%	STA 642+78.00	STA 643+18.00	STA 643+58.00	STA 643+98.00	STA 644+33.00
SN 086-0041 (EAST)	2.8%	STA 647+55.00	STA 647+15.00	STA 646+75.00	STA 646+35.00	STA 646+00.00

NOTE:

1. SUPERELEVATION CORRECTION TO BE DONE DURING PRE-STAGING SHOULDER REPLACEMENT.

MODEL: Default
 FILE NAME: p:\ultra-dwg-bead\ay.com\p\1\DOT\Documents\DOT Office\Dir\dir: E:\Project\0672136\CADD\data_S5\0\CAD\sheet\0672136-shr-cover.dgn

USER NAME = Frank.Caraballo	DESIGNED -	REVISED -
PLOT SCALE = 100,0000' / in.	DRAWN -	REVISED -
PLOT DATE = 12/14/2022	CHECKED -	REVISED -
	DATE -	REVISED -

STATE OF ILLINOIS
DEPARTMENT OF TRANSPORTATION

SHOULDER SUPERELEVATION TRANSITION DETAIL
SN 086-0040 & SN 086-0041

SCALE: SHEET OF SHEETS STA. TO STA.

F.A.I. RTE.	SECTION	COUNTY	TOTAL SHEETS	SHEET NO.
72	(86-8)BDR1,BJR1,BRR1,BP	SCOTT	45	27
ILLINOIS FED. AID PROJECT			CONTRACT NO. 72136	

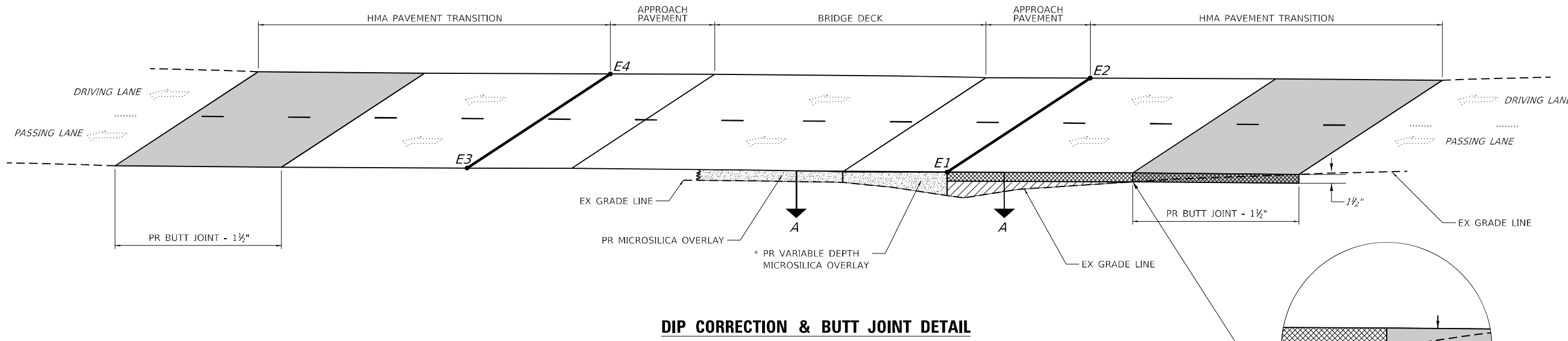

DIP CORRECTION & BUTT JOINT DETAIL

* TO BE PAID FOR ACCORDING TO SPECIAL PROVISION FOR BRIDGE DECK MICROSILICA CONCRETE OVERLAY.

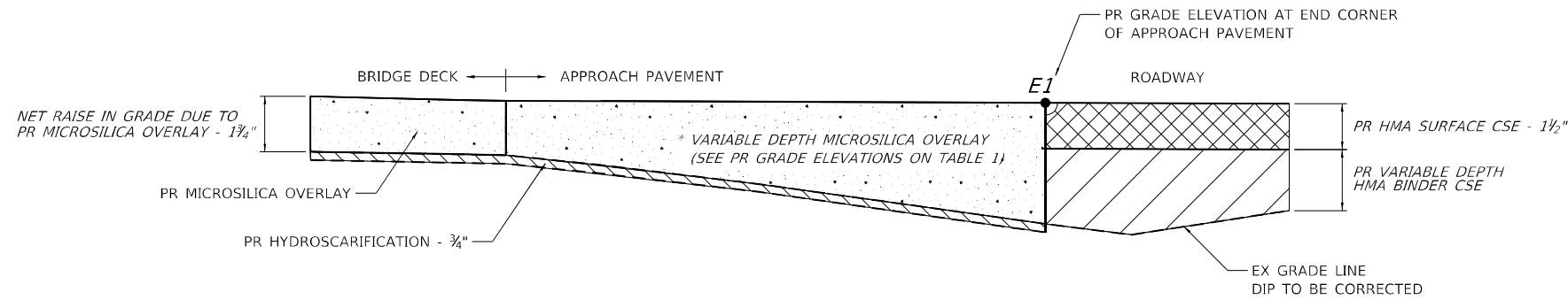
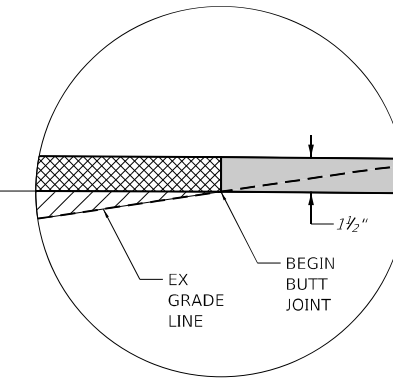

SECTION A-A

SN 086-0040 (EB I72)					
POINT NO.	STATION	OFFSET (FT)		PR ELEVATION (FT)	PR OVERLAY THICKNESS
E1	145+11.00	1.15	RT	445.85	2.9"
E2	145+10.00	24.9	RT	446.63	2.6"
E3	146+77.00	0.93	RT	445.86	3.2"
E4	146+76.00	24.83	RT	446.64	2.5"
SN 086-0041 (WB I72)					
POINT NO.	STATION	OFFSET (FT)		PR ELEVATION (FT)	PR OVERLAY THICKNESS
E1	645+99.00	0.21	LT	446.86	4.3"
E2	645+98.00	24	LT	447.53	4.6"
E3	644+34.00	0.16	LT	446.84	4.1"
E4	644+34.00	24	LT	447.5	4.3"

TABLE 1

MODEL: Default
 FILE NAME: p:\project\paw\benefit\com\paw\paw\DOT\Documents\DOT_offset\District_6\Project\0672136\CADD\data_55\0672136\sheet-cure.dgn
 PLOT SCALE = 100,0000' / in.
 PLOT DATE = 12/14/2022

USER NAME = Frank.Caraballo	DESIGNED -	REVISED -
	DRAWN -	REVISED -
	CHECKED -	REVISED -
	DATE -	REVISED -

**STATE OF ILLINOIS
DEPARTMENT OF TRANSPORTATION**

**DIP CORRECTION & BUTT JOINT DETAIL
SN 086-0040 & SN 086-0041**

SCALE: SHEET OF SHEETS STA. TO STA.

F.A.I. RTE.	SECTION	COUNTY	TOTAL SHEETS	SHEET NO.
72	(86-8)BDR1,BJR1,BRR1,BP	SCOTT	45	28
CONTRACT NO. 72136				
ILLINOIS FED. AID PROJECT				

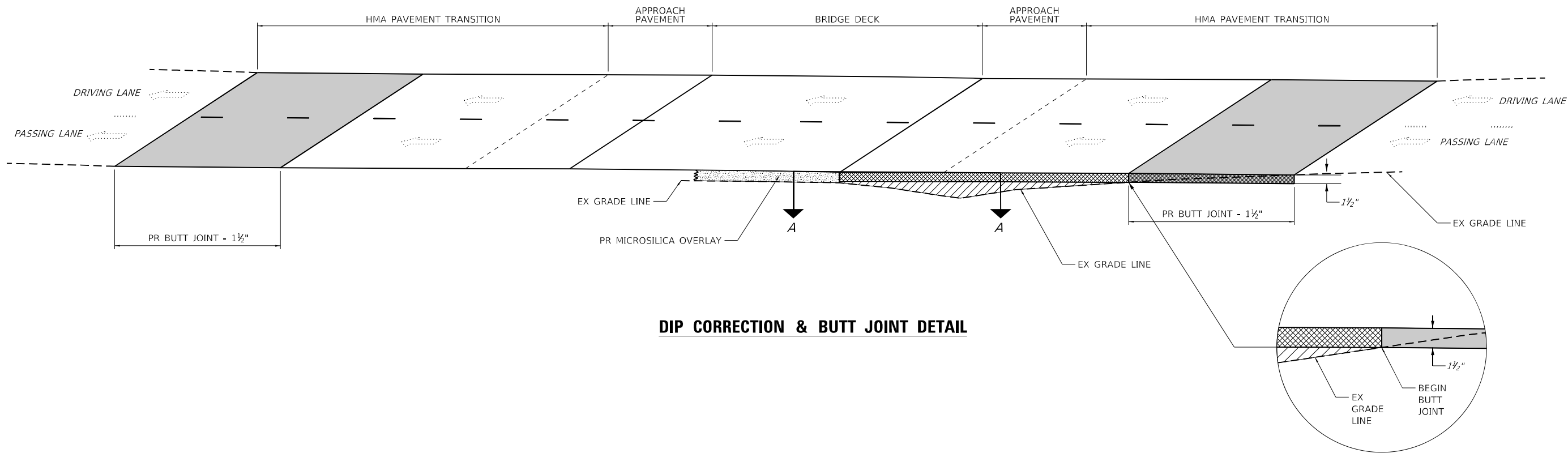

DIP CORRECTION & BUTT JOINT DETAIL

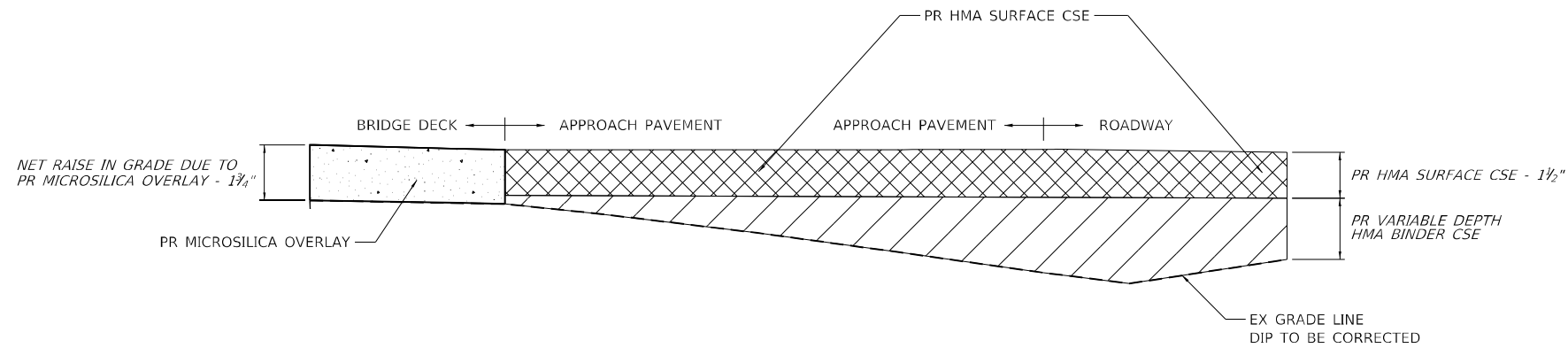

SECTION A-A

MODEL: Default
 FILE NAME: p:\project-aw-beadway.com\p\id\DOT\Documents\DOT_office\District_6\Project\0672136\CADD\data_55\0672136\h-cure.dgn

USER NAME = Frank.Caraballo	DESIGNED -	REVISED -
PLOT SCALE = 100,0000' / in.	DRAWN -	REVISED -
PLOT DATE = 12/14/2022	CHECKED -	REVISED -
	DATE -	REVISED -

**STATE OF ILLINOIS
DEPARTMENT OF TRANSPORTATION**

**DIP CORRECTION & BUTT JOINT DETAIL
SN 086-0042 & SN 086-0043**

SCALE: SHEET OF SHEETS STA. TO STA.

F.A.I. RTE.	SECTION	COUNTY	TOTAL SHEETS	SHEET NO.
72	(86-8)BDR1,BJR1,BRR1,BP	SCOTT	45	29
CONTRACT NO. 72136				
ILLINOIS FED. AID PROJECT				

DETAIL: INLET BOXES TO BE ADJUSTED

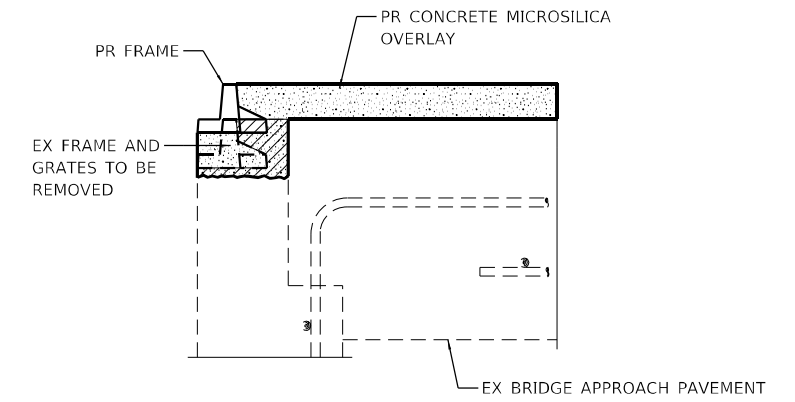
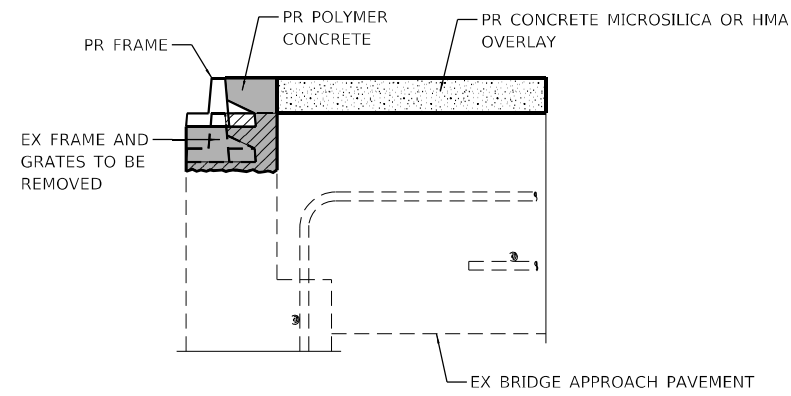
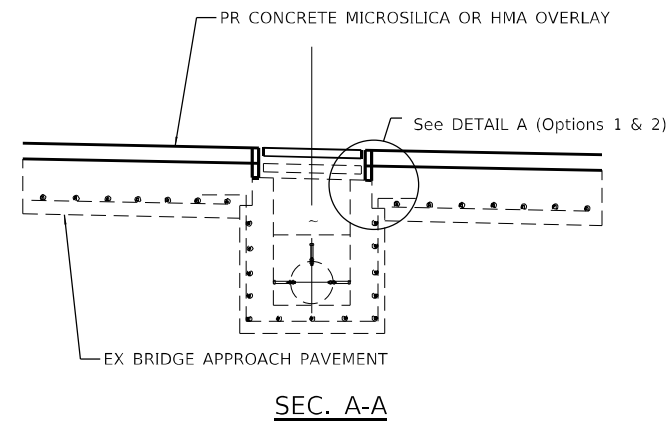

- POLYMER CONCRETE
- CONCRETE REMOVAL
- CONCRETE MICROSILICA OR HMA OVERLAY

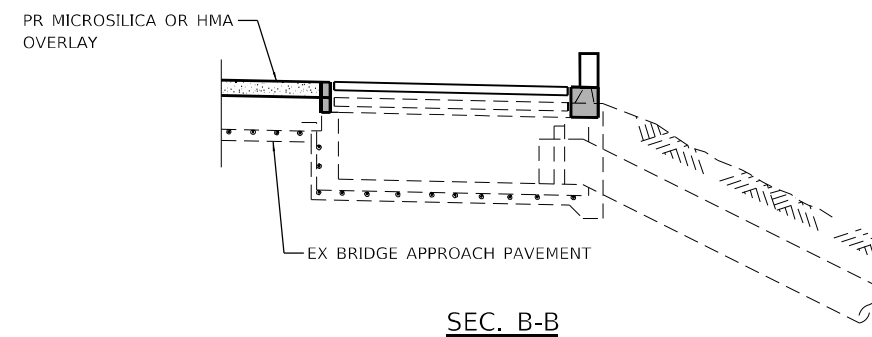
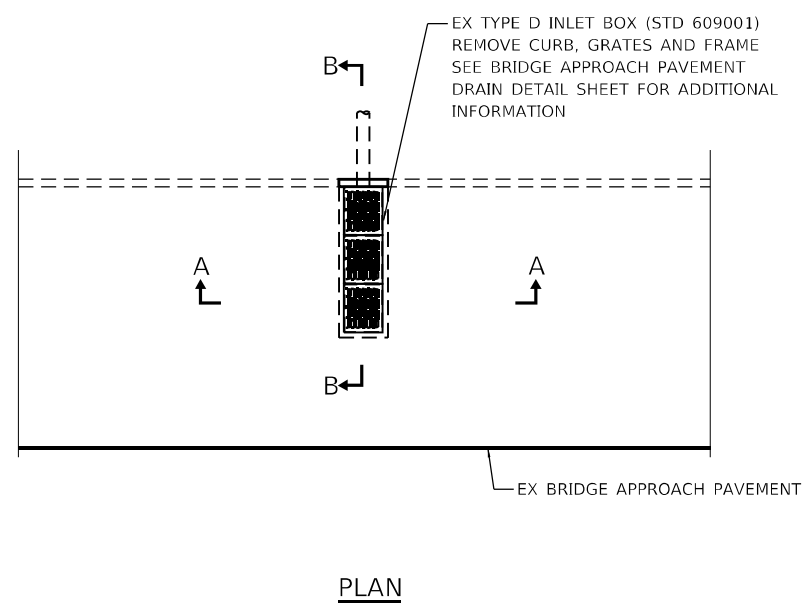

- CONCRETE MICROSILICA OR POLYMER CONCRETE
SEE OPTIONS 1 & 2 ABOVE

STATE OF ILLINOIS
DEPARTMENT OF TRANSPORTATION

**INLET TO BE ADJUSTED WITH NEW FRAME AND GRATE
DETAIL**

SCALE: SHEET OF SHEETS STA. TO STA.

F.A.I. RTE.	SECTION	COUNTY	TOTAL SHEETS	SHEET NO.
72	(86-8)BDR1,BJR1,BRR1,BP	SCOTT	45	30
CONTRACT NO. 72136				
ILLINOIS FED. AID PROJECT				

MODEL: Default
 FILE: Mainfile.pia
 SUBJECT: new benchtop.com/PIV/IDOT/Documents/IDOT_Offices/District_6/Project/0672136/CA/06/Sheet/0672136_sht-detailed.dgn

USER NAME = Frank.Caraballo	DESIGNED -	REVISED -
PLOT SCALE = 100,0000' / in.	DRAWN -	REVISED -
PLOT DATE = 12/15/2022	CHECKED -	REVISED -
	DATE -	REVISED -

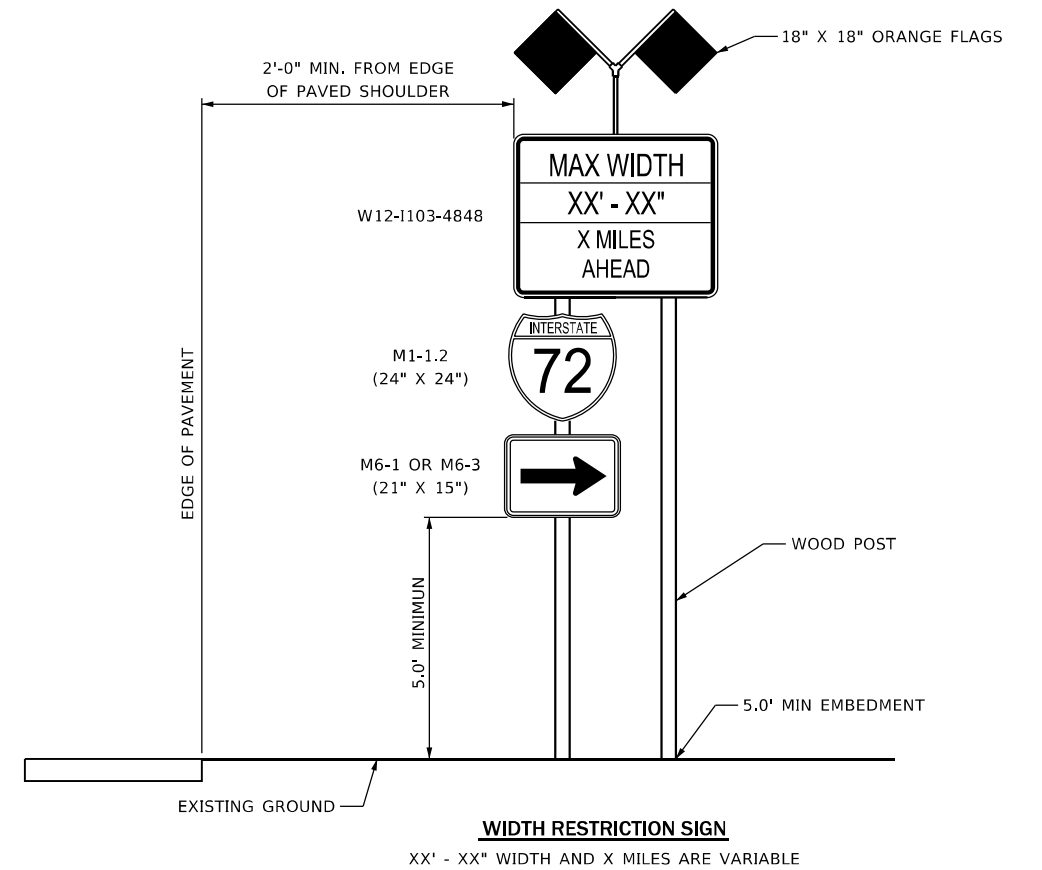
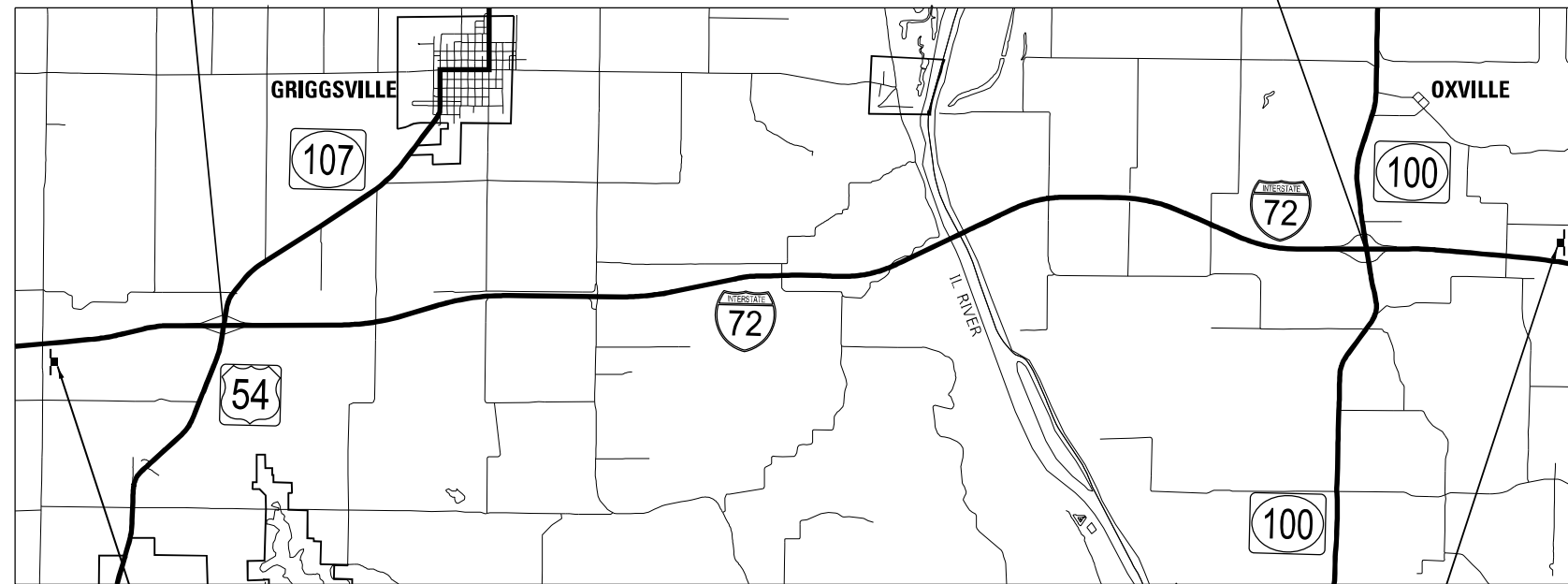
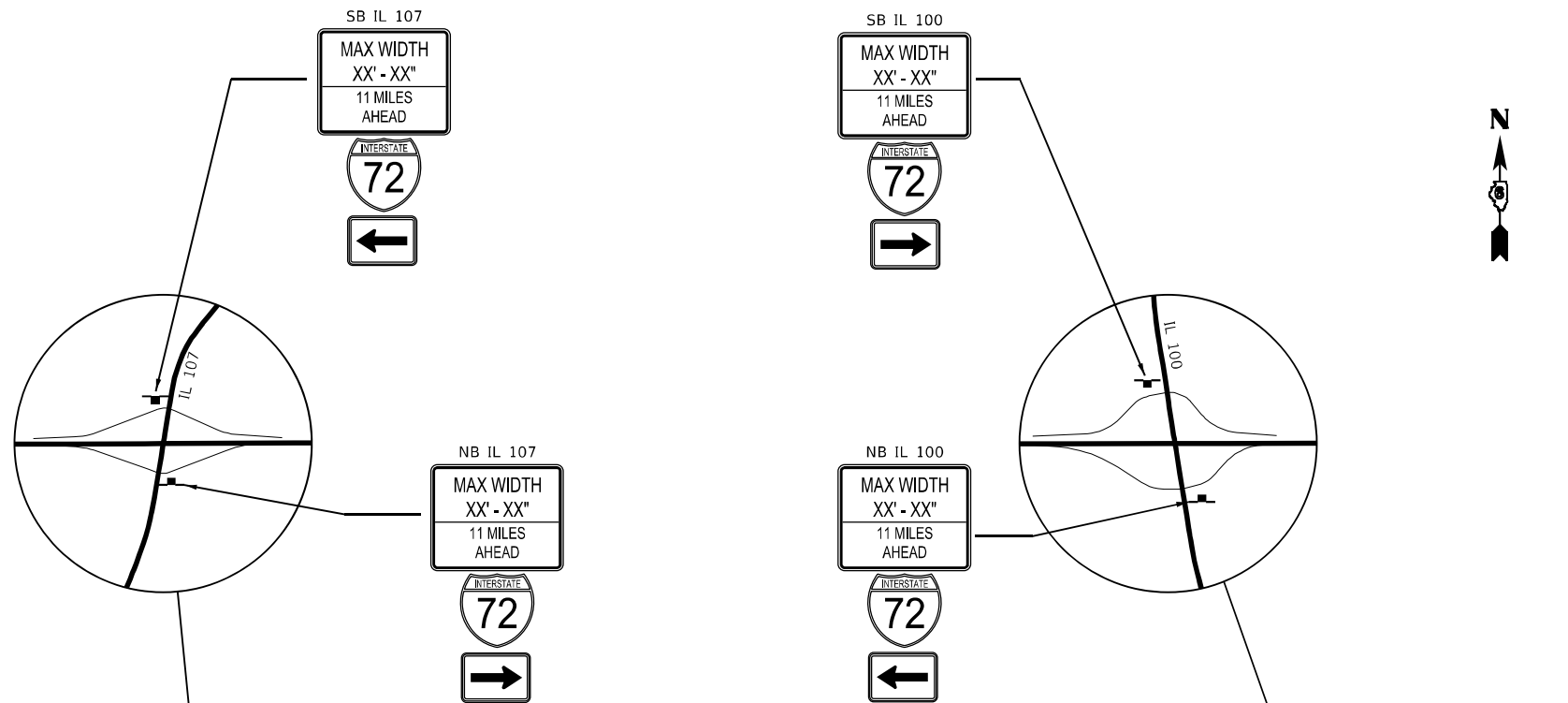

MODEL: Default
 FILE: Mainfile.pxd
 SUBJECT: new benchmarks.com\FWIDOT\Documents\DOT Office\Director_E\Project\0672136\CADD\data_S5\0672136\CADD\sheet\0672136-sheet-cover.dgn

USER NAME = Frank,Caraballo	DESIGNED -	REVISED -
DRAWN -	REVISOR -	
PLOT SCALE = 100,0000' / in.	CHECKED -	REVISOR -
PLOT DATE = 12/14/2022	DATE -	REVISOR -

**STATE OF ILLINOIS
DEPARTMENT OF TRANSPORTATION**

**WIDTH RESTRICTION SIGNING
DETAIL**

SCALE: SHEET OF SHEETS STA. TO STA.

F.A.I. RTE.	SECTION	COUNTY	TOTAL SHEETS	SHEET NO.
72	(86-8)BDR1,BJR1,BRR1,BP	SCOTT	45	31
CONTRACT NO. 72136				
ILLINOIS FED. AID PROJECT				

GENERAL NOTES

Plan dimensions and details relative to existing plans are subject to nominal construction variations. The Contractor shall field verify existing dimensions and details affecting new construction and make necessary approved adjustments prior to construction or ordering of materials. Such variations shall not be cause for additional compensation for a change in scope of the work, however, the Contractor will be paid for the quantity actually furnished at the unit price bid for the work. Traffic will be maintained using stage construction. Clean the washout area under drains and install Class A4 Riprap in accordance with the Standard Specifications. Engineer should verify the width of washout area. Quantity shown is an estimate. Engineer shall determine the quantity of Riprap at the project location. The overlay thickness in excess of 2 3/4" shall be paid for as outlined in the special provisions for Bridge Deck Concrete Overlay, 2 3/4"

OVERLAY THICKNESS TABLE

(Prior to 1/4" Grinding)

LOCATION POINTS	0040 (EB)	0041 (WB)
N.W. Corner of W. Approach - P1	3 1/2"	5 3/8"
S.W. Corner of W. Approach - P2	4 1/4"	5 1/8"
N.E. Corner of E. Approach - P3	3 5/8"	5 1/2"
S.E. Corner of E. Approach - P4	3 7/8"	5 3/8"

TOTAL BILL OF MATERIAL

ITEM	UNIT	QUANTITY
Bridge Deck Scarification 3/4"	Sq. Yd.	1242
Diamond Grinding (Bridge Section)	Sq. Yd.	1150
* Protective Coat	Sq. Yd.	1242
Bridge Deck Microsilica Concrete Overlay, 2 3/4"	Sq. Yd.	1242
** Deck Slab Repair (Full Depth, Type II)	Sq. Yd.	5
Bridge Deck Grooving (Longitudinal)	Sq. Yd.	873
Polymer Concrete	Cu. Ft.	41
Stone Riprap, Class A4	Sq. Yd.	1

* Apply to new concrete only.
** Quantity is estimated. Location and size of patches to be determined in the field by the Engineer.

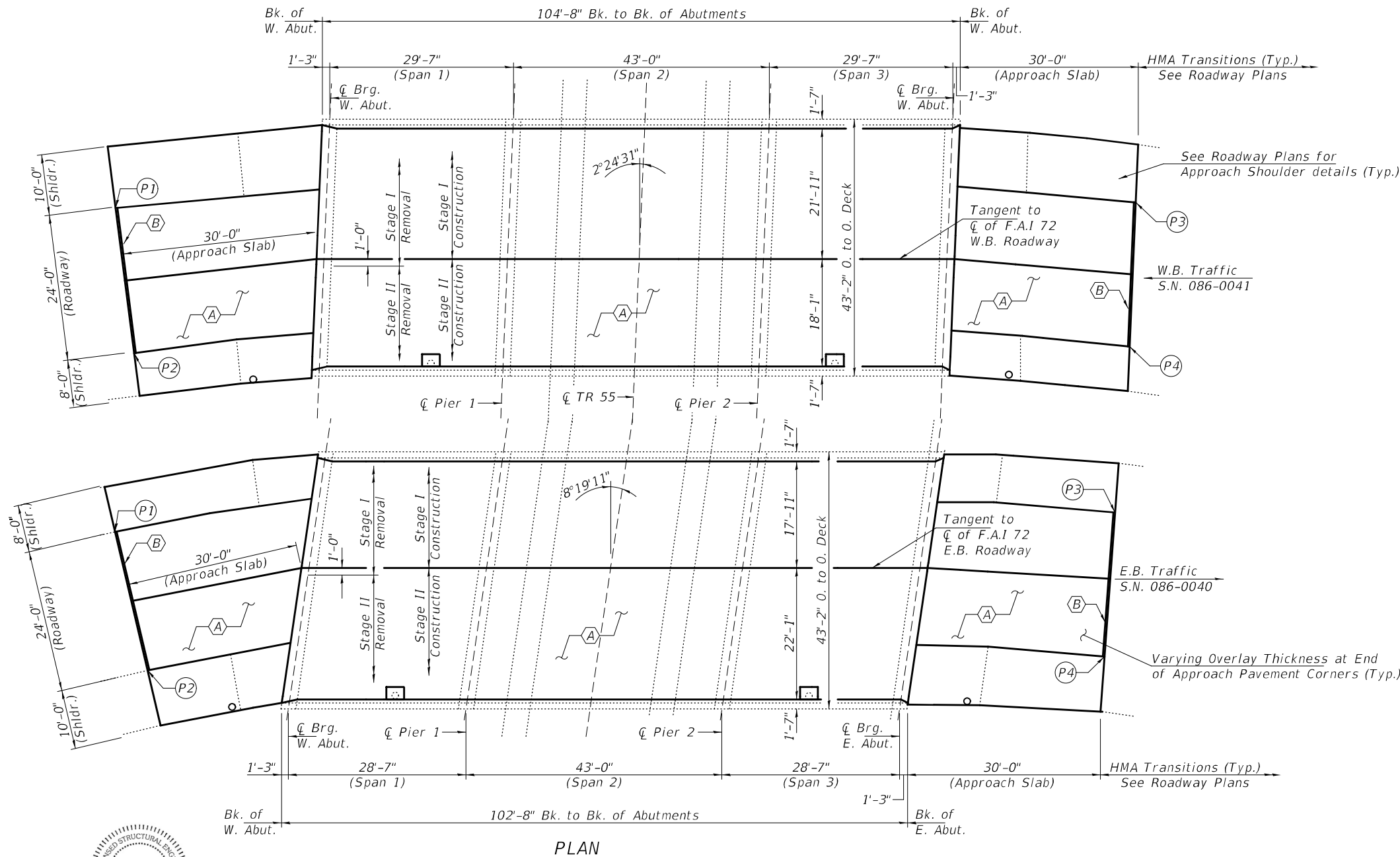
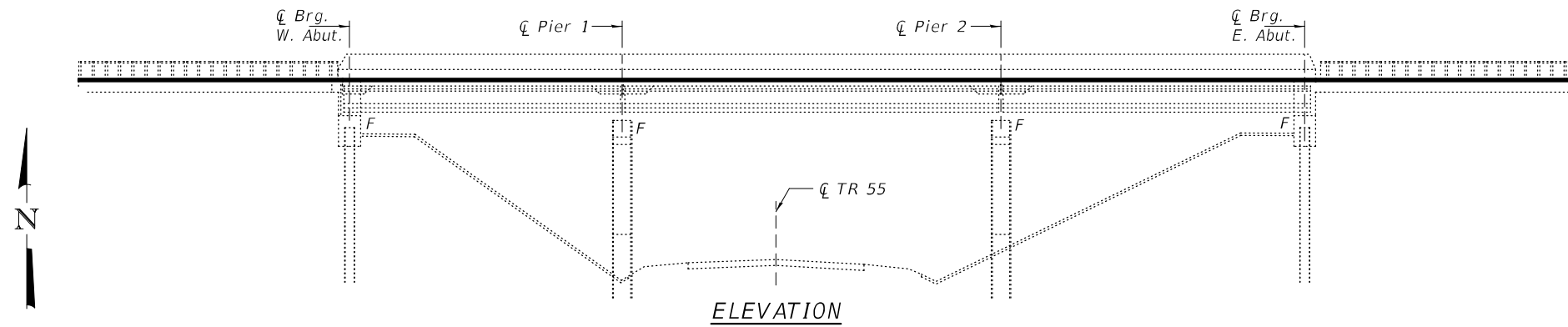

(A) - 3/4" Bridge Deck Scarification, 2 3/4" min. Microsilica Concrete Overlay & 1/4" Diamond Grinding

(B) - Polymer Concrete Nosing (See Repair B).

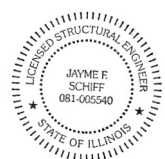

EXPIRES 11-30-2024

DESIGNED - Adrian T. Holloway
CHECKED - Chi-Cheung Chai
DRAWN - Venkat Ramana Reddy
CHECKED - ATH CCC

PASSED

Jayme F. Schiff
ENGINEER OF BRIDGES AND STRUCTURES

DATE - February 2, 2023

REVISED -
REVISED -

STATE OF ILLINOIS
DEPARTMENT OF TRANSPORTATION

GENERAL PLAN AND ELEVATION
F.A.P. 408 (F.A.I. 72) OVER TR 55
SN 086-0040 (EB) & 086-0041 (WB)

SHEET NO. 1 OF 2 SHEETS

F.A.I. RTE.	SECTION	COUNTY	TOTAL SHEETS	SHEET NO.
72	(86-8) BDR1,BUR1,BRR1,BP	SCOTT	45	32
			CONTRACT NO. 72136	
ILLINOIS FED. AID PROJECT				

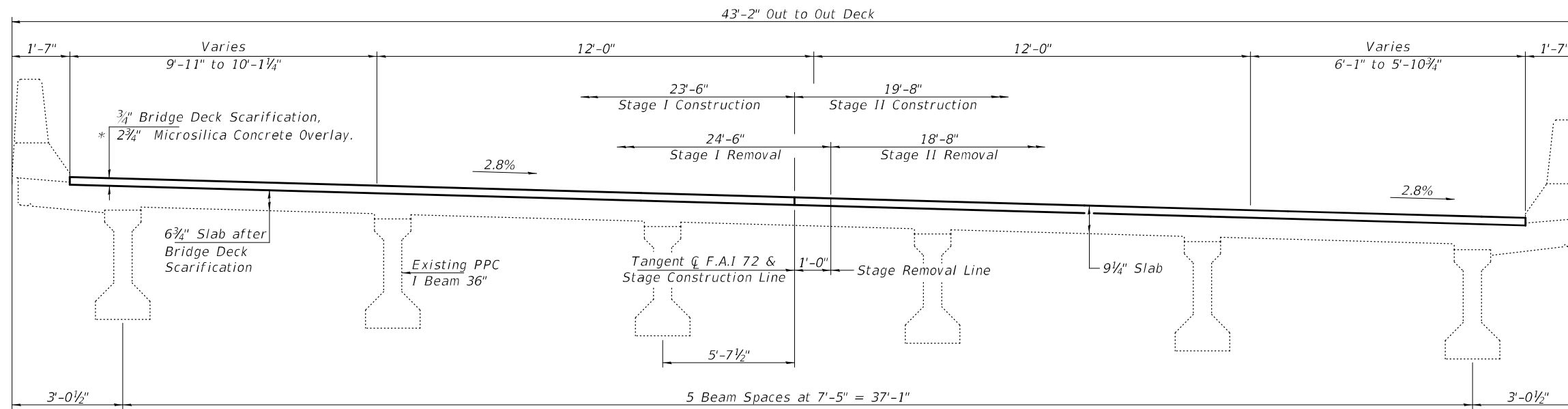

CROSS SECTION 086-0041 (WB)

(Looking East)

* Prior to 1/4" Diamond Grinding

43'-2" Out to Out Deck

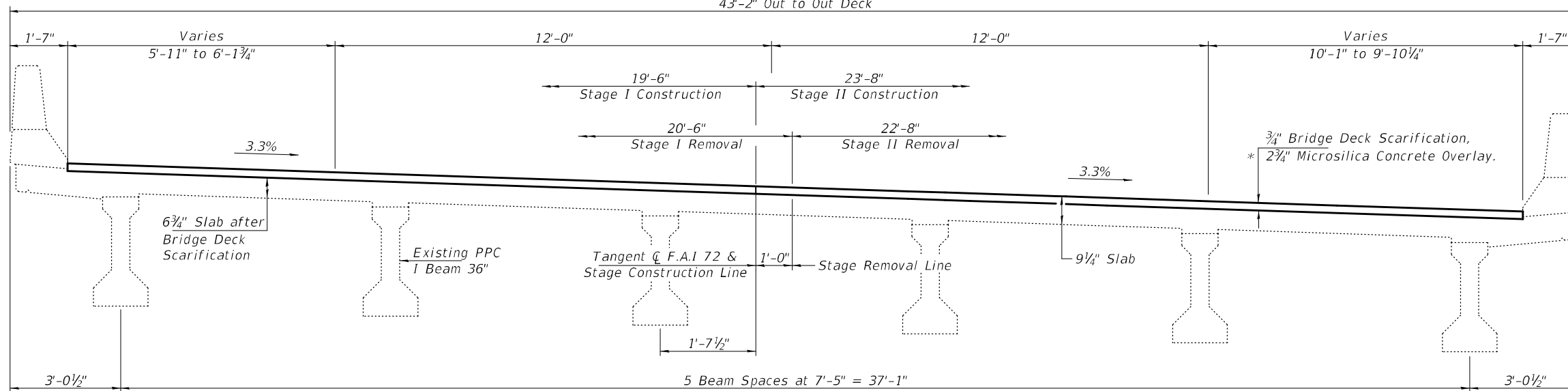

CROSS SECTION 086-0040 (EB)

(Looking East)

Vary overlay on approach to correct dip and cross slope. (See table on Sheet 1 of 2)

Bk. of Abut. See Detail A

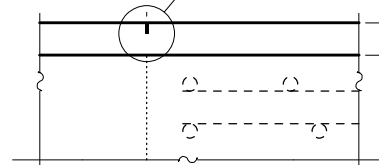

SECTION AT ABUTMENT

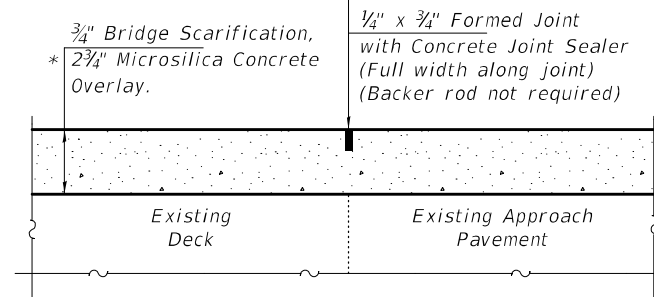

DETAIL A

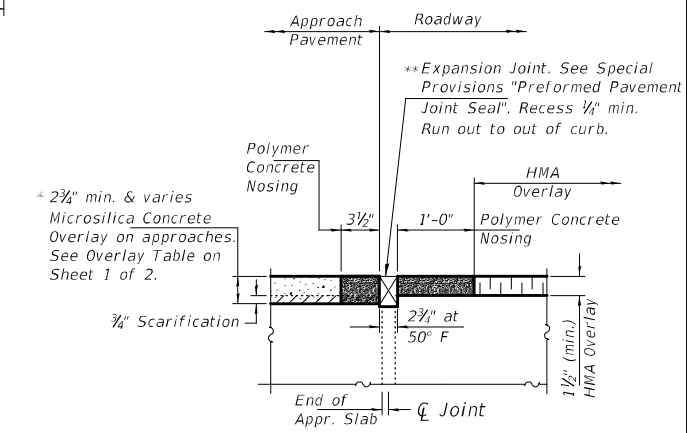

REPAIR B

* Prior to 1/4" Diamond Grinding
** Cost included with Polymer Concrete

3/4" Bridge Deck Scarification,
* 2 3/4" Microsilica Concrete Overlay.

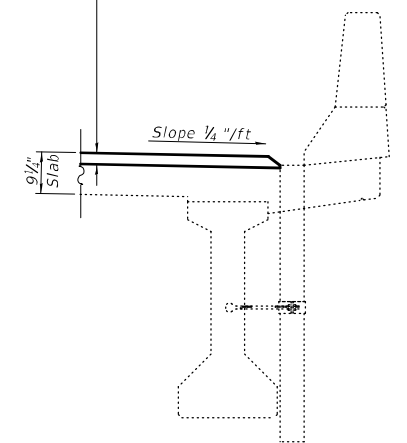

SECTION THRU PARAPET

(at drain)

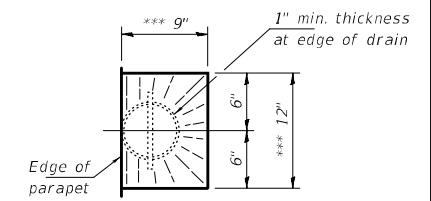

DRAIN DETAIL

*** slope to drain

DESIGNED - ATH
CHECKED - CCC
DRAWN - Venkat Ramana Reddy
CHECKED - ATH CCC

PASSED

Jaime F. [Signature]
ENGINEER OF BRIDGES AND STRUCTURES

DATE - February 2, 2023

REVISED -
REVISED -

STATE OF ILLINOIS
DEPARTMENT OF TRANSPORTATION

CROSS SECTIONS & STAGING DETAILS
SN 086-0040 (EB) & 086-0041 (WB)

SHEET NO. 2 OF 2 SHEETS

F.A.I. RTE.	SECTION	COUNTY	TOTAL SHEETS	SHEET NO.
72	(86-8) BDR1,BJR1,BRR1,BP	SCOTT	45	33
CONTRACT NO. 72136				
ILLINOIS FED. AID PROJECT				

GENERAL NOTES

All structural steel shall conform to AASHTO Classification M-270 Gr. 36, unless otherwise noted.

Plan dimensions and details relative to existing plans are subject to nominal construction variations. The Contractor shall field verify existing dimensions and details affecting new construction and make necessary approved adjustments prior to construction or ordering of materials. Such variations shall not be cause for additional compensation for a change in scope of the work, however, the Contractor will be paid for the quantity actually furnished at the unit price bid for the work.

Prior to pouring the new concrete deck, all heavy or loose rust, loose mill scale, and other loose or potentially detrimental foreign material shall be removed from the surfaces in contact with concrete. Tightly adhered paint may remain unless otherwise noted. Removal shall be accomplished by methods that will not damage the steel and the cost will be included in the pay item covering removal of the existing concrete.

Reinforcement bars designated (E) shall be epoxy coated.

Existing reinforcement bars extending into the removal area shall be cleaned, straightened and incorporated into the new construction. Any reinforcement bars that are damaged during concrete removal shall be replaced with an approved bar splicer or anchorage system. Cost included with Concrete Removal.

Joint openings shall be adjusted according to Article 520.04 of the Standard Specifications when the deck is poured at an ambient temperature other than 50° F. Traffic will be maintained using stage construction.

Cleaning and painting of the existing structural steel shall be specified in the special provision for "Cleaning and Painting Existing Steel Structures". All beams within 10 ft. of the beam ends shall be cleaned per Near White Blast Cleaning (SSPC-SP10).

The designated areas cleaned per Near White Blast Cleaning (SSPC-SP10) shall be painted according to the requirements of Paint System 1 (OZ/E/U). The color of the final finish coat for all steel surfaces shall be Gray, Munsell No. 5B 7/1.

SSPC-QP1 Painting Contractor Certifications will be required for this contract. A minimum of one (1) air monitor is required for this project.

The overlay thickness in excess of 2 3/4" shall be paid for as outlined in the special provisions for Bridge Deck Microsilica Concrete Overlay, 2 3/4".

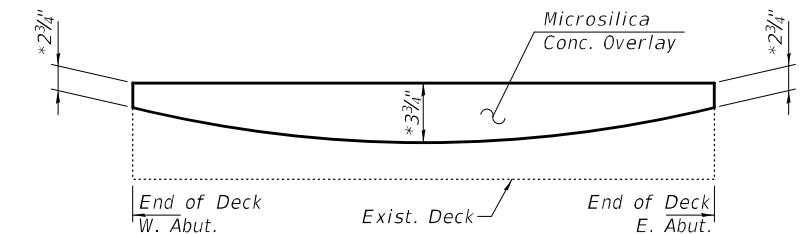

OVERLAY DETAIL

* Prior to 1/4" Diamond Grinding

TOTAL BILL OF MATERIAL

ITEM	UNIT	QUANTITY
Bridge Deck Scarification 3/4"	Sq. Yd.	2184
Diamond Grinding (Bridge Section)	Sq. Yd.	1991
* Protective Coat	Sq. Yd.	2222
* Bridge Deck Microsilica Concrete Overlay, 2 3/4"	Sq. Yd.	2184
Reinforcement Bars, Epoxy Coated	Pound	3000
Concrete Removal	Cu. Yd.	21.5
Deck Slab Repair (Full Depth, Type II)	Sq. Yd.	32
** Approach Slab Repair (Partial Depth)	Sq. Yd.	40
Bridge Deck Grooving (Longitudinal)	Sq. Yd.	1328
Concrete Superstructure	Cu. Yd.	25.0
Structural Repair of Concrete (Depth ≤ 5")	Sq. Ft.	283
Cleaning and Painting Steel Bridge No. 1	L. Sum	1
Cleaning and Painting Steel Bridge No. 2	L. Sum	1
Containment and Disposal of Non-Lead Paint Residues No. 1	L. Sum	1
Containment and Disposal of Non-Lead Paint Residues No. 2	L. Sum	1
Inlets to be Adjusted with New Frame and Grate (Special)	Each	8
Preformed Joint Strip Seal	Foot	168
Bar Splicers	Each	48

* Apply to new concrete only.

** Quantity is estimated. Location and size of patches to be determined in the field by the Engineer.

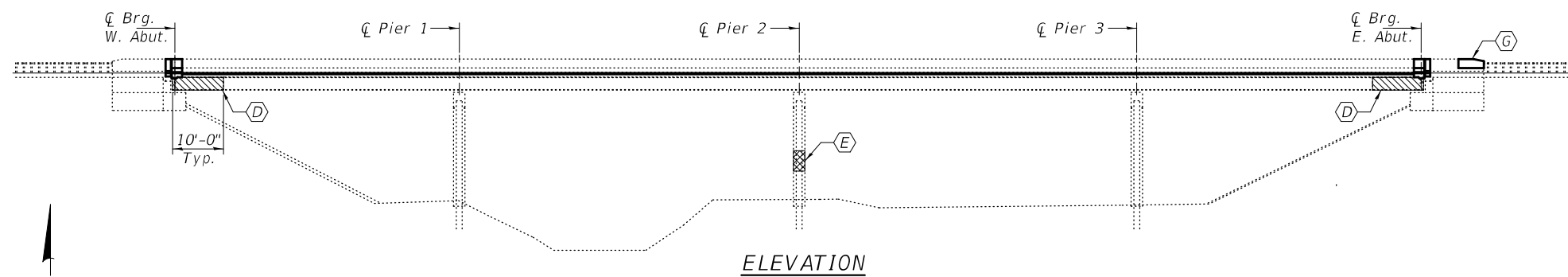

ELEVATION

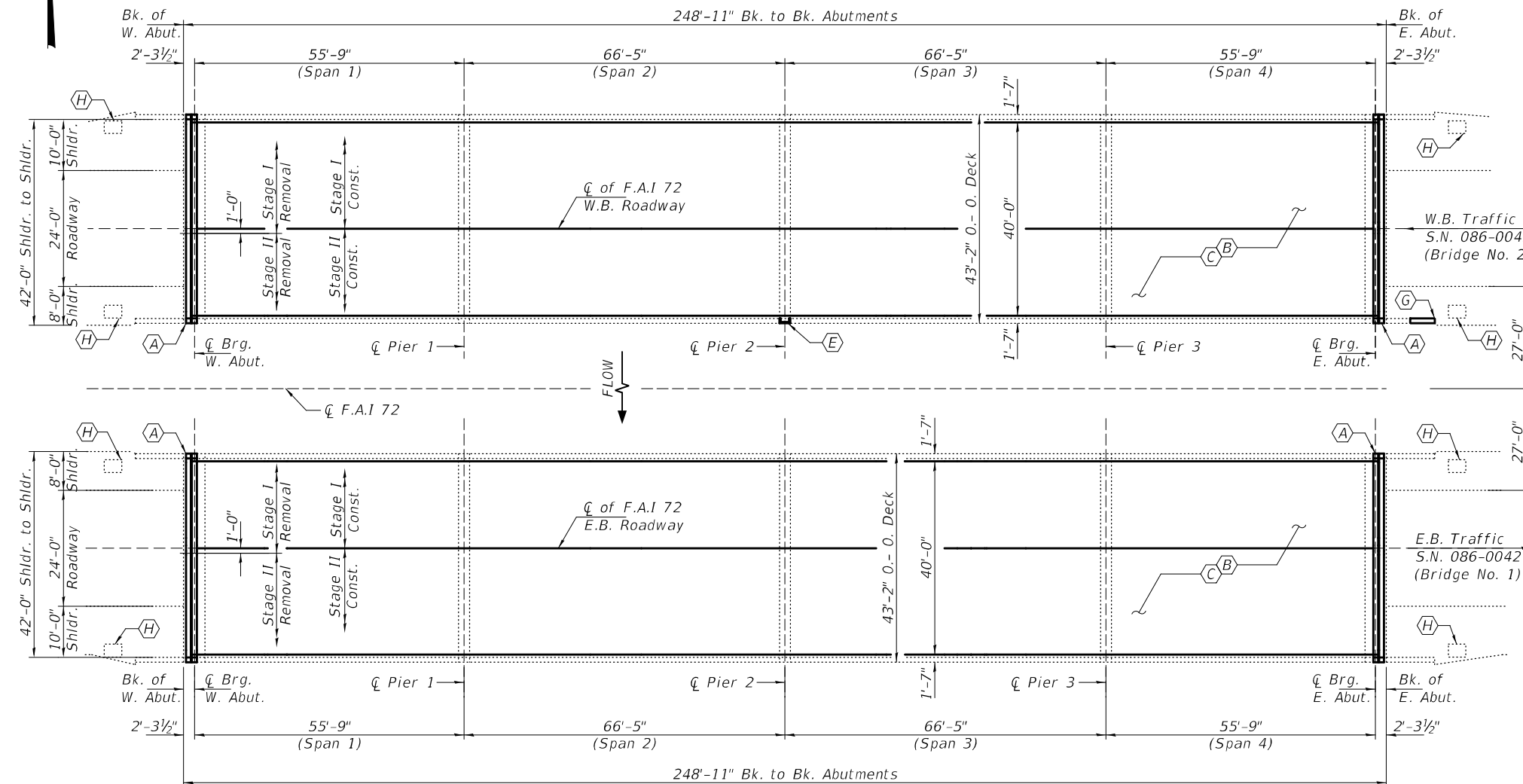

PLAN

- (A) - Remove existing Neoprene Joints and install New Preformed Joint Strip Seal.
- ** (B) - Deck Patching (Full Depth).
- (C) - 3/4" Bridge Deck Scarification, 2 3/4" min. Microsilica Concrete Overlay & 1/4" Diamond Grinding.
- (D) - Blast and paint Beam Ends up to 10ft, End Diaphragms & Abutment Bearings.
- (E) - Substructure Repairs.
- (F) - Approach Slab Repair (Partial Depth).
- (G) - Parapet Repair.
- (H) - Approach Inlet Grate Adjustment.

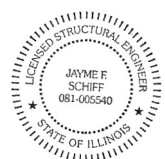

EXPIRES 11-30-2024

DESIGNED - Adrian T. Halloway
 CHECKED - Chi-Cheung Chai
 DRAWN - Venkat Ramana Reddy
 CHECKED - ATH CCC

PASSED
 Jayme F. Schiff
 ENGINEER OF BRIDGES AND STRUCTURES

DATE - February 2, 2023
 REVISED -
 REVISED -

STATE OF ILLINOIS
 DEPARTMENT OF TRANSPORTATION

GENERAL PLAN AND ELEVATION
 FAI 72 (US RTE 36) OVER DRAINAGE DITCH
 SN 086-0042 (EB) & 0043 (WB)

SHEET NO. 1 OF 15 SHEETS

F.A.I. RTE.	SECTION	COUNTY	TOTAL SHEETS	SHEET NO.
72	(86-8) BDR1,BJR1,BRR1,BP	SCOTT	45	34
CONTRACT NO. 72136				
ILLINOIS / FED. AID PROJECT				

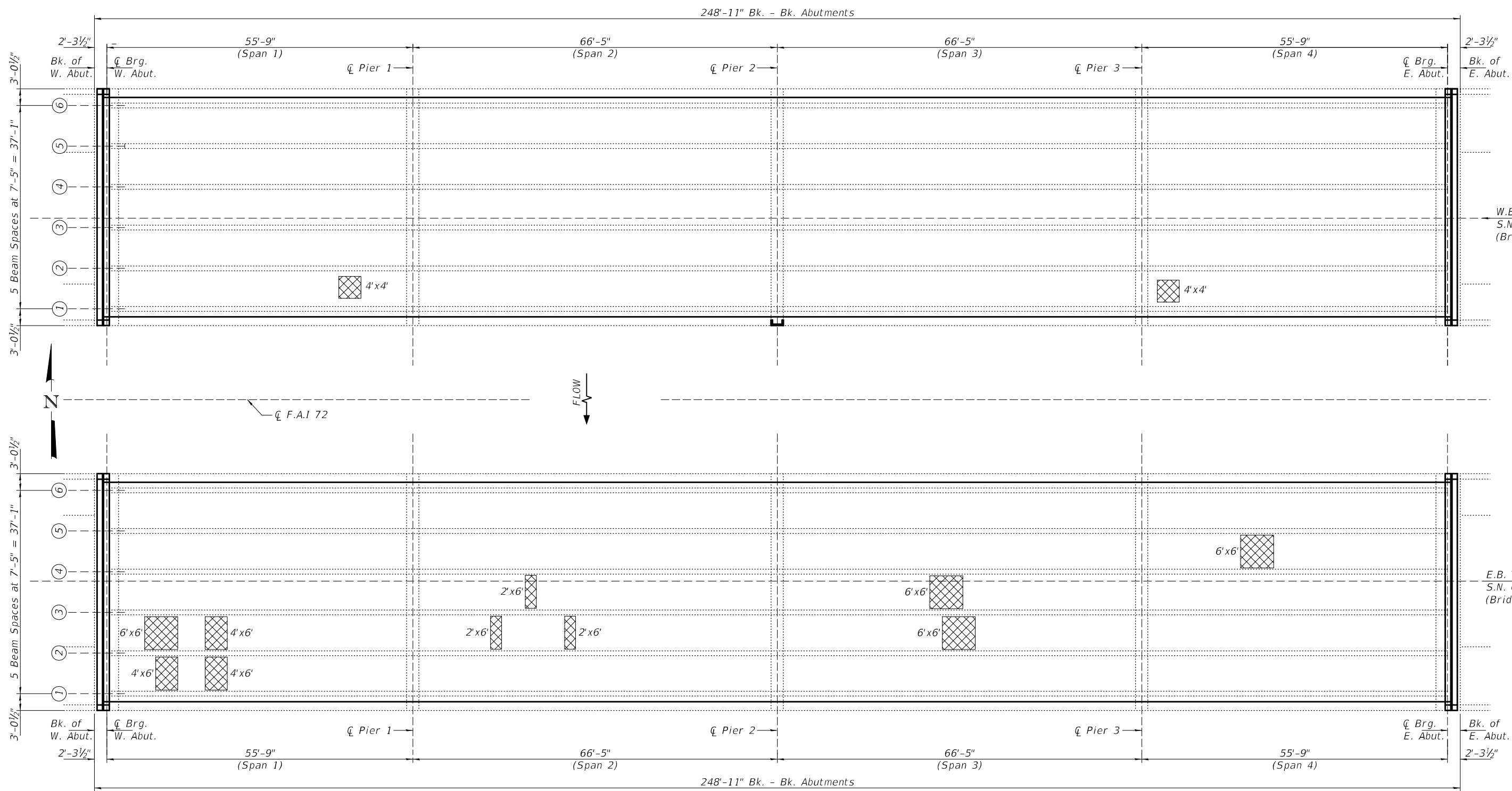

PLAN

BILL OF MATERIAL
(FOR INFORMATION ONLY)

Deck Slab Repair (Full Depth, Type II)

Item	Unit	Total
Deck Slab Repair (Full Depth, Type II)	Sq. Yd.	32

DESIGNED - ATH
 CHECKED - CCC
 DRAWN - Venkat Ramana Reddy
 CHECKED - ATH CCC

PASSED

 ENGINEER OF BRIDGES AND STRUCTURES

DATE - February 2, 2023
 REVISED -
 REVISED -

STATE OF ILLINOIS
DEPARTMENT OF TRANSPORTATION

DECK REPAIR DETAILS
SN 086-0042 (EB) & 0043 (WB)

SHEET NO. 2 OF 15 SHEETS

F.A.I. RTE.	SECTION	COUNTY	TOTAL SHEETS	SHEET NO.
72	(86-8) BDR1,BJR1,BRR1,BP	SCOTT	45	35

CONTRACT NO. 72136
 ILLINOIS FED. AID PROJECT

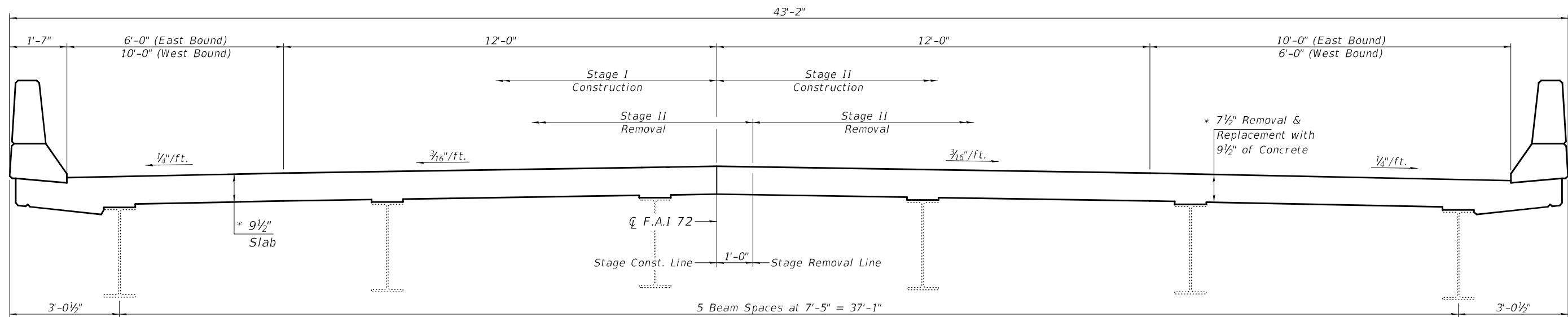

CROSS SECTION AT ABUTMENTS

(SN 086-0042 E.B. Looking East)
(SN 086-0043 W.B. Looking East)

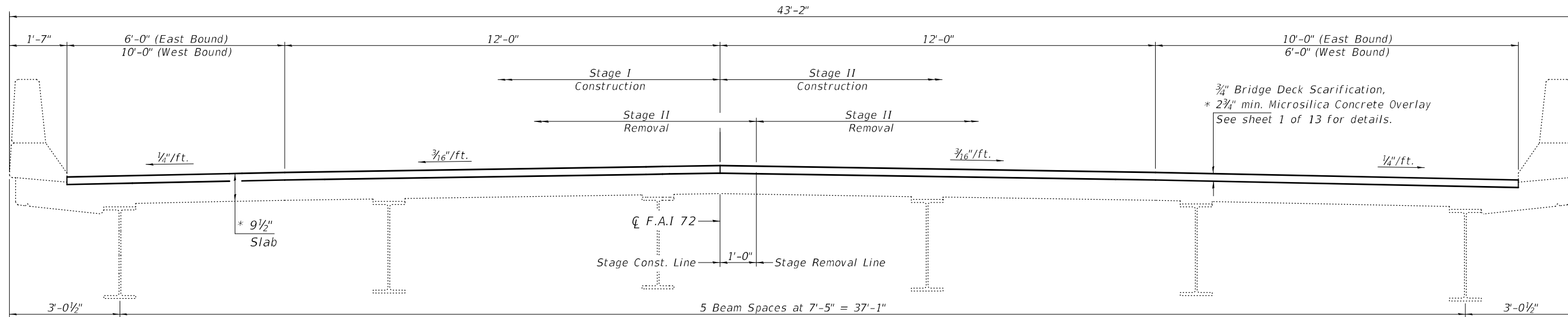

CROSS SECTION AT MID SPAN

(SN 086-0042 E.B. Looking East)
(SN 086-0043 W.B. Looking East)

* Prior to 1/4" Diamond Grinding

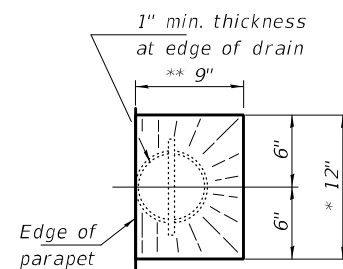

DRAIN DETAIL

** slope to drain

3/4" Bridge Scarification
* 2 3/4" min. Microsilica
Concrete Overlay. See
sheet 1 of 13 for details.

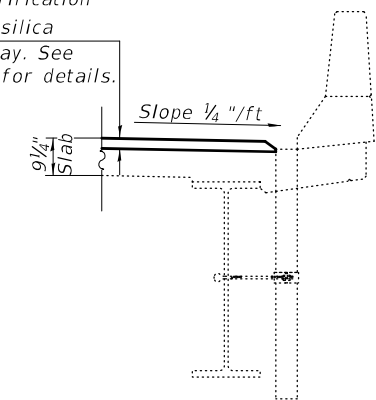

SECTION THRU PARAPET

(at drain)

DESIGNED - ATH
CHECKED - CCC
DRAWN - Venkat Ramana Reddy
CHECKED - ATH CCC

PASSED

Joey F. [Signature]
ENGINEER OF BRIDGES AND STRUCTURES

DATE - February 2, 2023

REVISED -
REVISED -

**STATE OF ILLINOIS
DEPARTMENT OF TRANSPORTATION**

**CROSS SECTIONS & STAGING DETAILS
SN 086-0042 (EB) & 0043 (WB)**

SHEET NO. 3 OF 15 SHEETS

F.A.I. RTE.	SECTION	COUNTY	TOTAL SHEETS	SHEET NO.
72	(86-8) BDR1,BJR1,BRR1,BP	SCOTT	45	36
CONTRACT NO. 72136				
ILLINOIS FED. AID PROJECT				

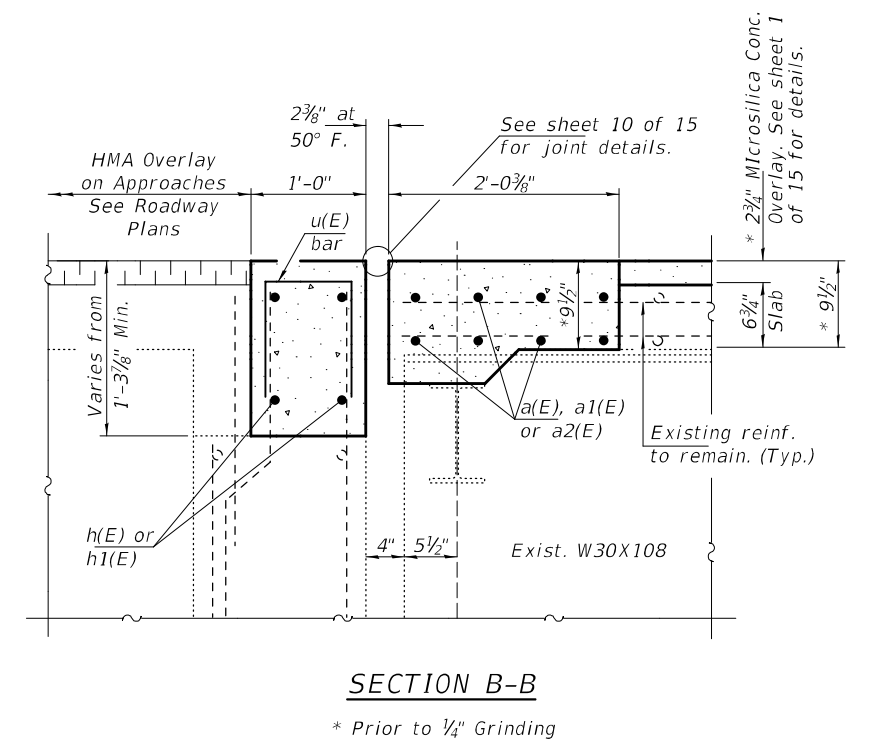
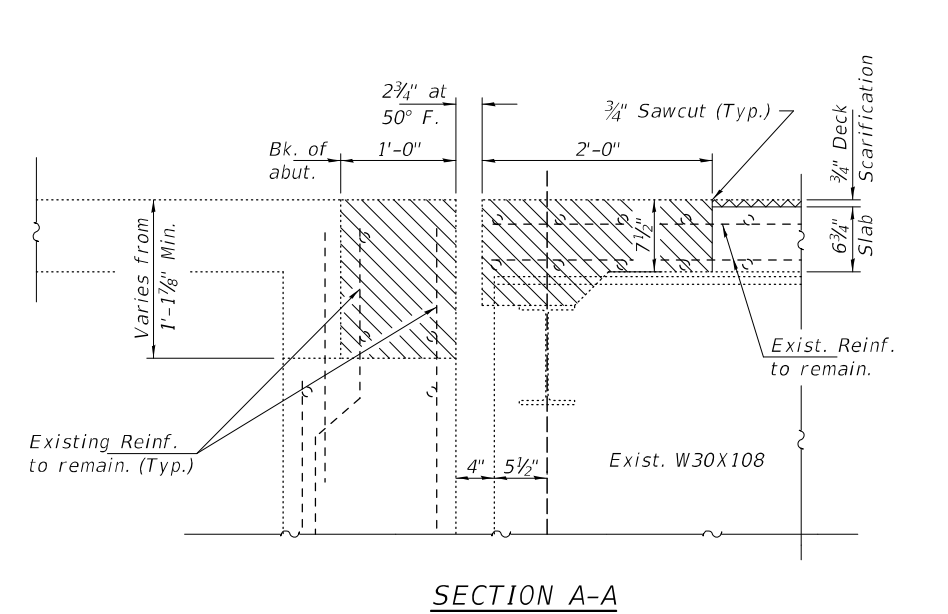
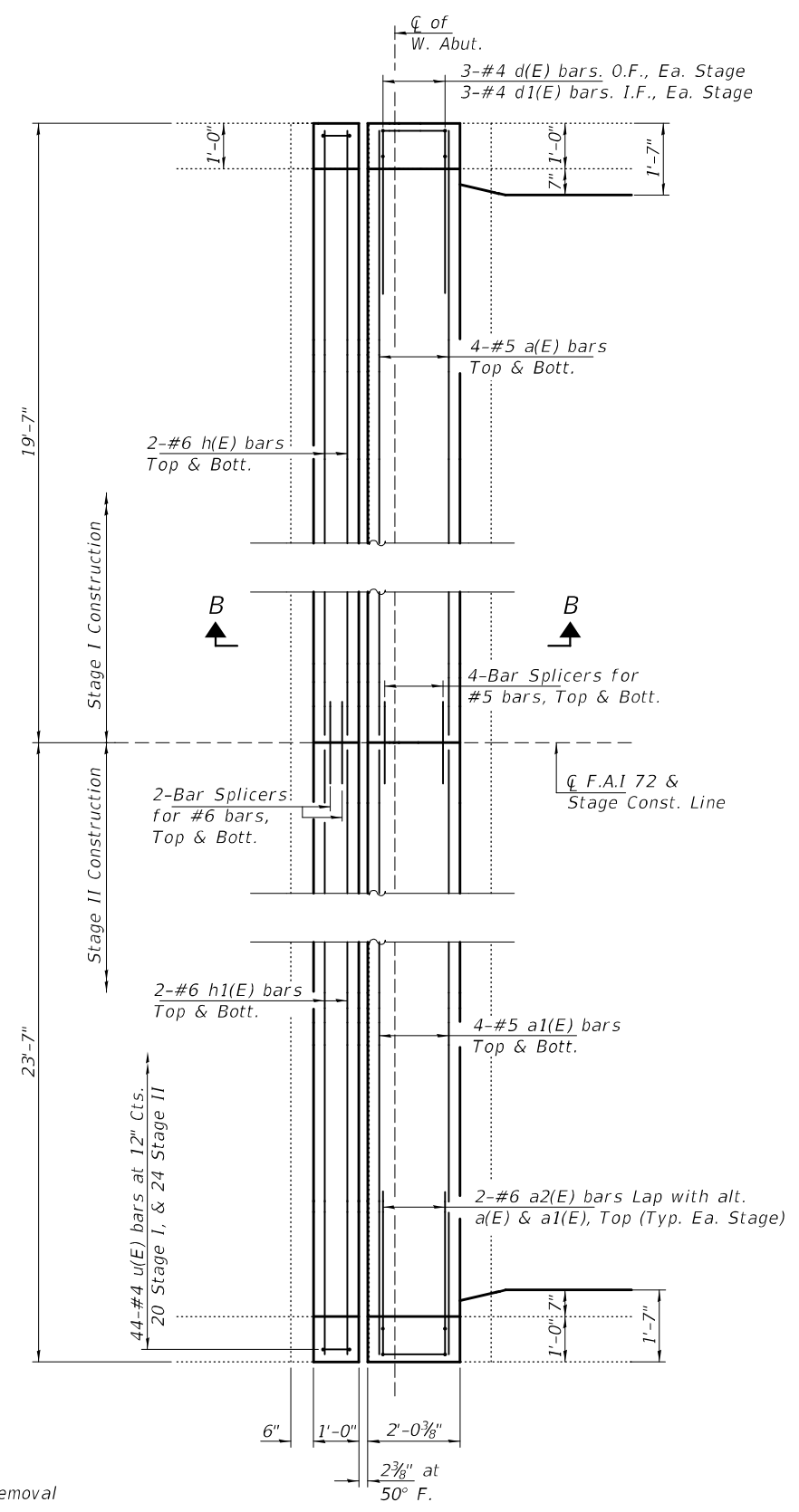
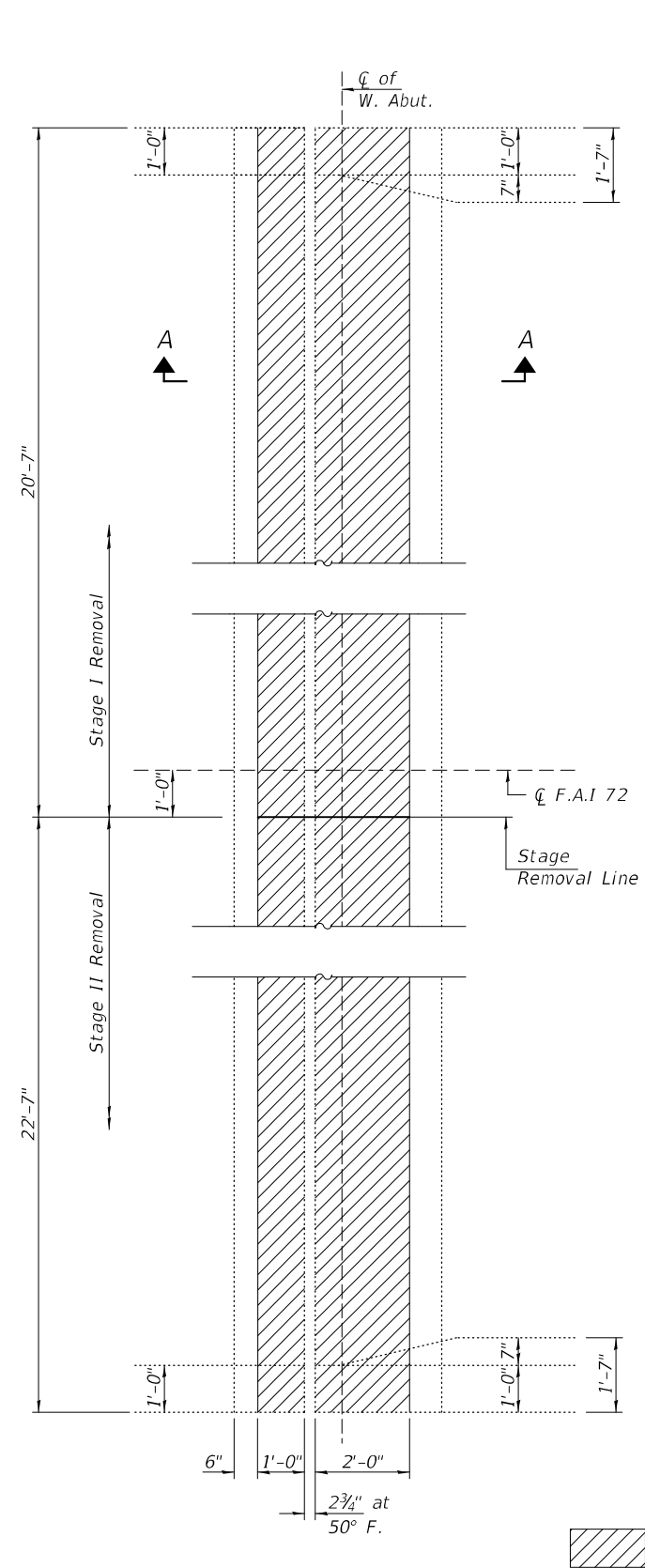

Note:
See Sheet 6 of 15 for Reinforcement and Parapet Details.

DESIGNED - ATH	PASSED	 ENGINEER OF BRIDGES AND STRUCTURES	DATE - February 2, 2023	STATE OF ILLINOIS DEPARTMENT OF TRANSPORTATION	JOINT REMOVAL & REPLACEMENT DETAILS SN 086-0042 (EB)	F.A.I. RTE.	SECTION	COUNTY	TOTAL SHEETS	SHEET NO.
CHECKED - CCC			REVISED -			72	(86-8) BDR1,BJR1,BRR1,BP	SCOTT	45	37
DRAWN - Venkat Ramana Reddy			REVISED -			CONTRACT NO. 72136				
CHECKED - ATH CCC			ILLINOIS FED. AID PROJECT							

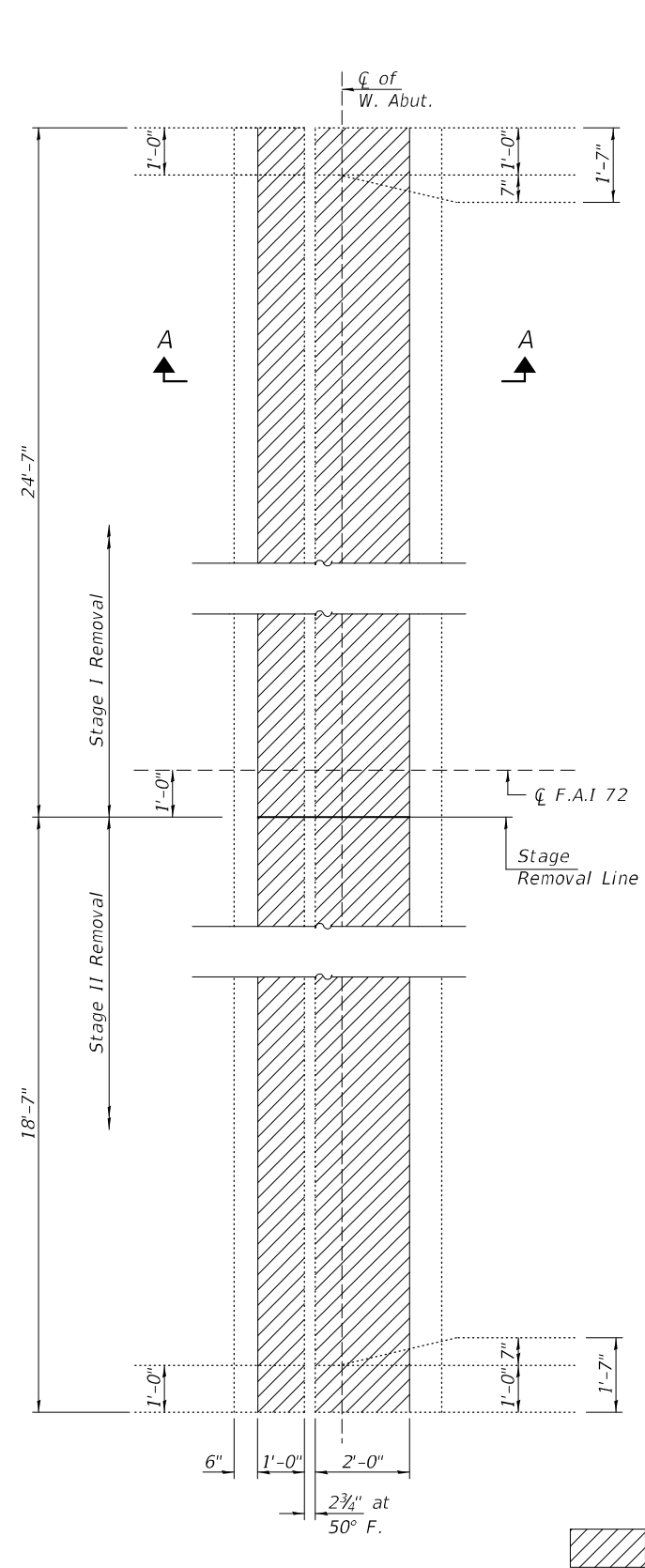

REMOVAL PLAN

West Abut. shown, East Abut. similar by mirroring along \bar{C} Pier 2

Concrete Removal

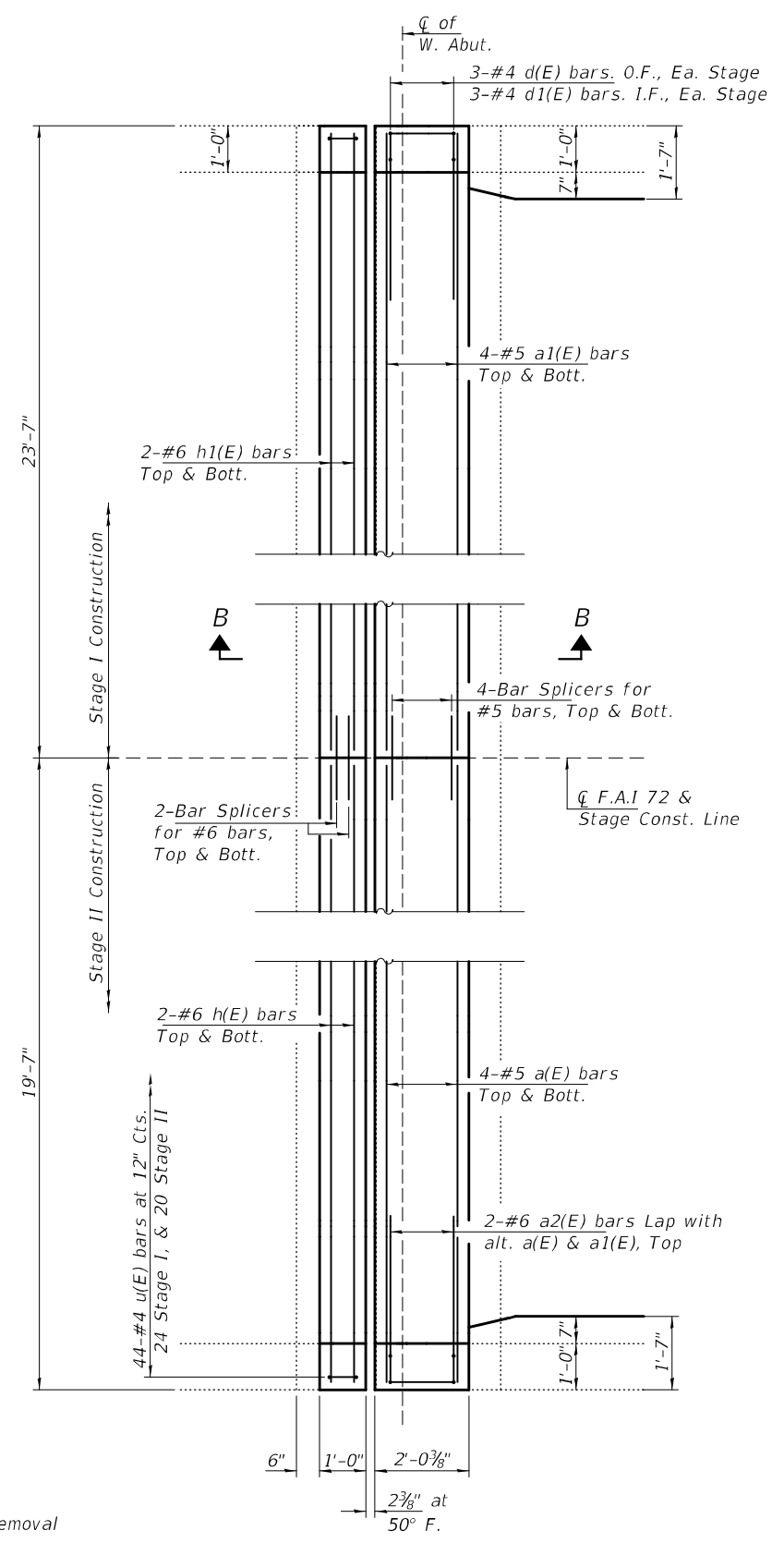

REPLACEMENT PLAN

West Abut. shown, East Abut. similar by mirroring along \bar{C} Pier 2

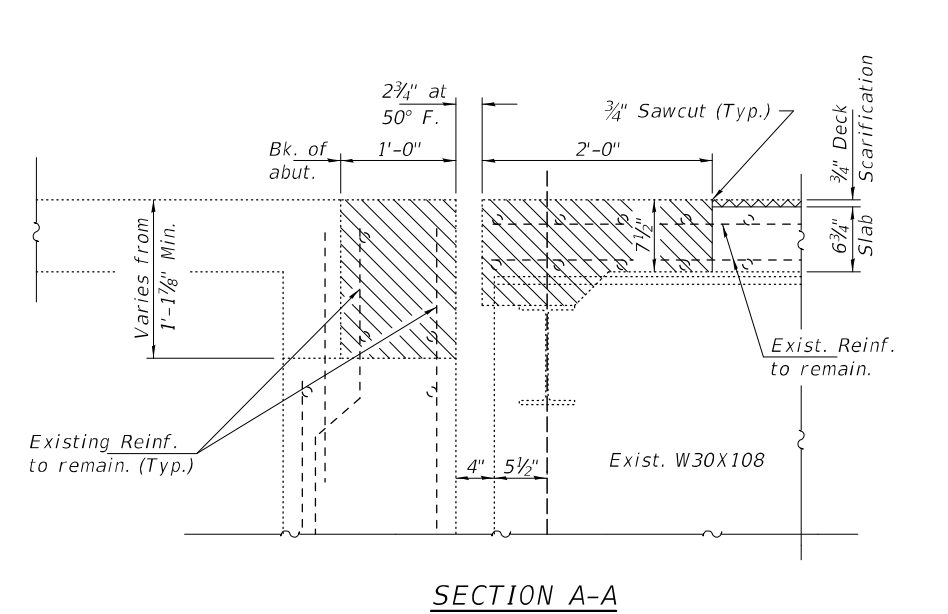

SECTION A-A

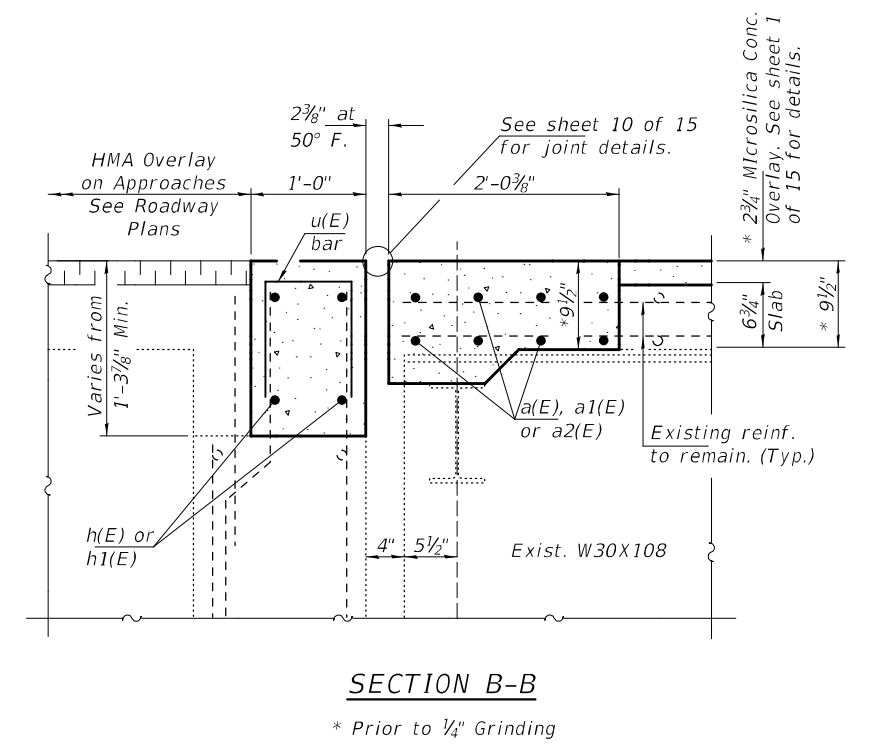

SECTION B-B

* Prior to 1/4" Grinding

Note: See Sheet 6 of 15 for Reinforcement and Parapet Details.

DESIGNED - ATH	PASSED		DATE - February 2, 2023	STATE OF ILLINOIS DEPARTMENT OF TRANSPORTATION	JOINT REMOVAL & REPLACEMENT DETAILS SN 086-0043 (WB)	F.A.I. RTE.	SECTION	COUNTY	TOTAL SHEETS	SHEET NO.
CHECKED - CCC			REVISD -			72	(86-8) BDR1,BJR1,BRR1,BP	SCOTT	45	38
DRAWN - Venkat Ramana Reddy			REVISD -			CONTRACT NO. 72136				
CHECKED - ATH CCC			ENGINEER OF BRIDGES AND STRUCTURES			ILLINOIS FED. AID PROJECT				

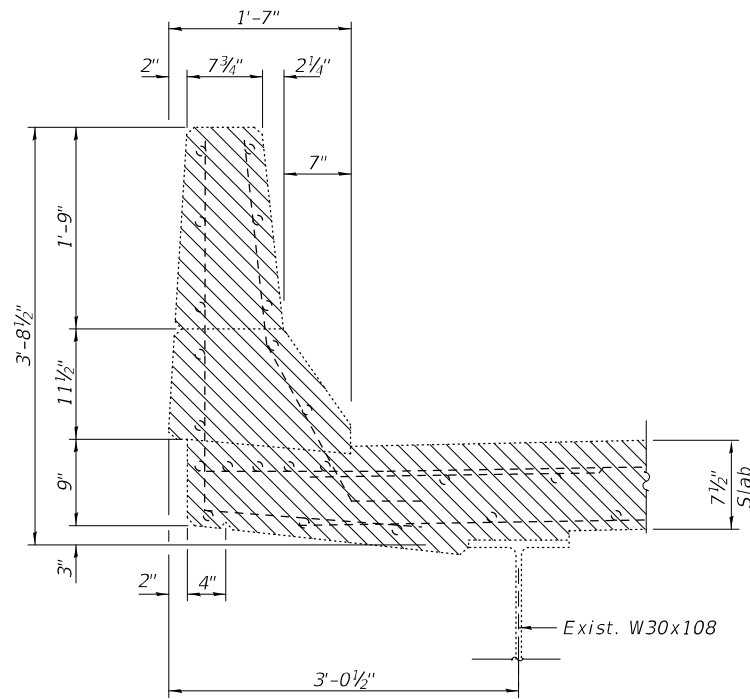

REMOVAL DETAILS

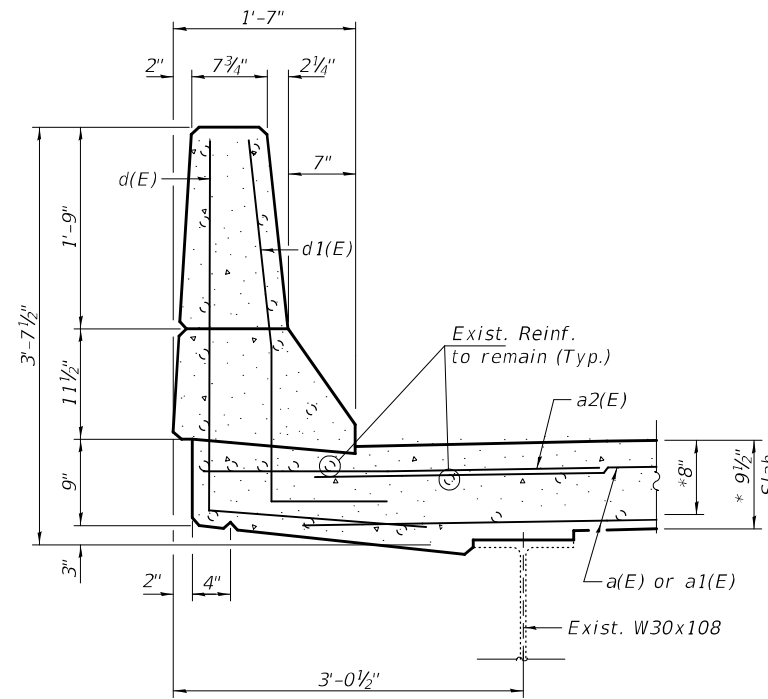

REPLACEMENT DETAILS

* Prior to 1/4" Grinding

SECTION THRU BRIDGE PARAPET AT BOTH ABUTMENTS

Concrete Replacement

Concrete Replacement

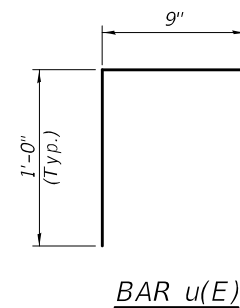
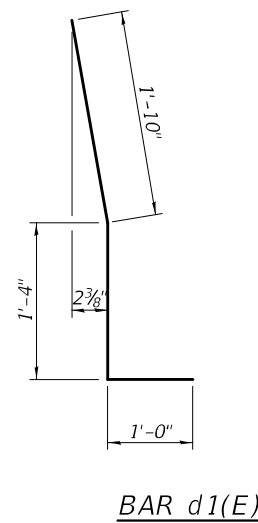
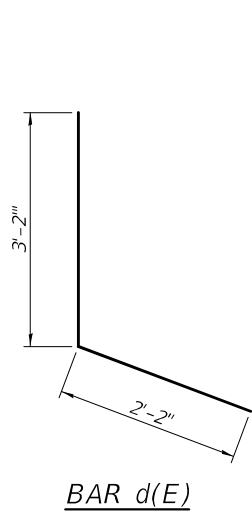

BILL OF MATERIAL

Bar	No.	Size	Length	Shape
a(E)	32	#5	18'-6"	—
a1(E)	32	#5	22'-6"	—
a2(E)	16	#6	4'-0"	—
d(E)	24	#4	5'-4"	L
d1(E)	24	#5	4'-2"	L
h(E)	16	#6	19'-3"	—
h1(E)	16	#6	23'-3"	—
u(E)	176	#4	2'-9"	U
Concrete Removal			Cu. Yd.	21.5
Concrete Superstructure			Cu. Yd.	25.0
Protective Coat			Sq. Yd.	2222
Bar Splicers			Each	48
Reinforcement Bars, Epoxy Coated			Pound	3000

DESIGNED - ATH
 CHECKED - CCC
 DRAWN - Venkat Ramana Reddy
 CHECKED - ATH CCC

PASSED

Jaime F. J. [Signature]
 ENGINEER OF BRIDGES AND STRUCTURES

DATE - February 2, 2023

REVISED -
 REVISED -

**STATE OF ILLINOIS
 DEPARTMENT OF TRANSPORTATION**

**JOINT REMOVAL & REPLACEMENT DETAILS
 SN 086-0042 (EB) & 0043 (WB)**

SHEET NO. 6 OF 15 SHEETS

F.A.I. RTE.	SECTION	COUNTY	TOTAL SHEETS	SHEET NO.
72	(86-8) BDR1,BJR1,BRR1,BP	SCOTT	45	39
CONTRACT NO. 72136				
ILLINOIS FED. AID PROJECT				

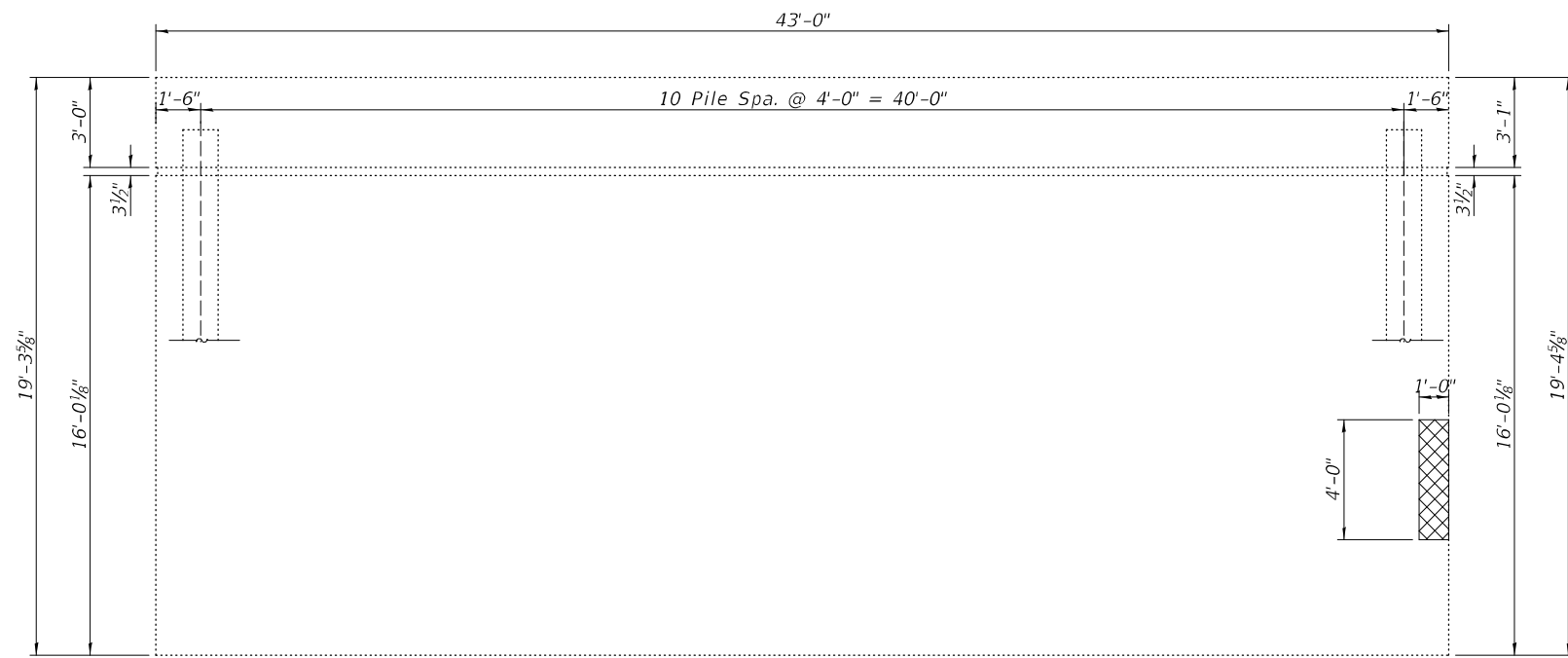

ELEVATION
(Looking East)

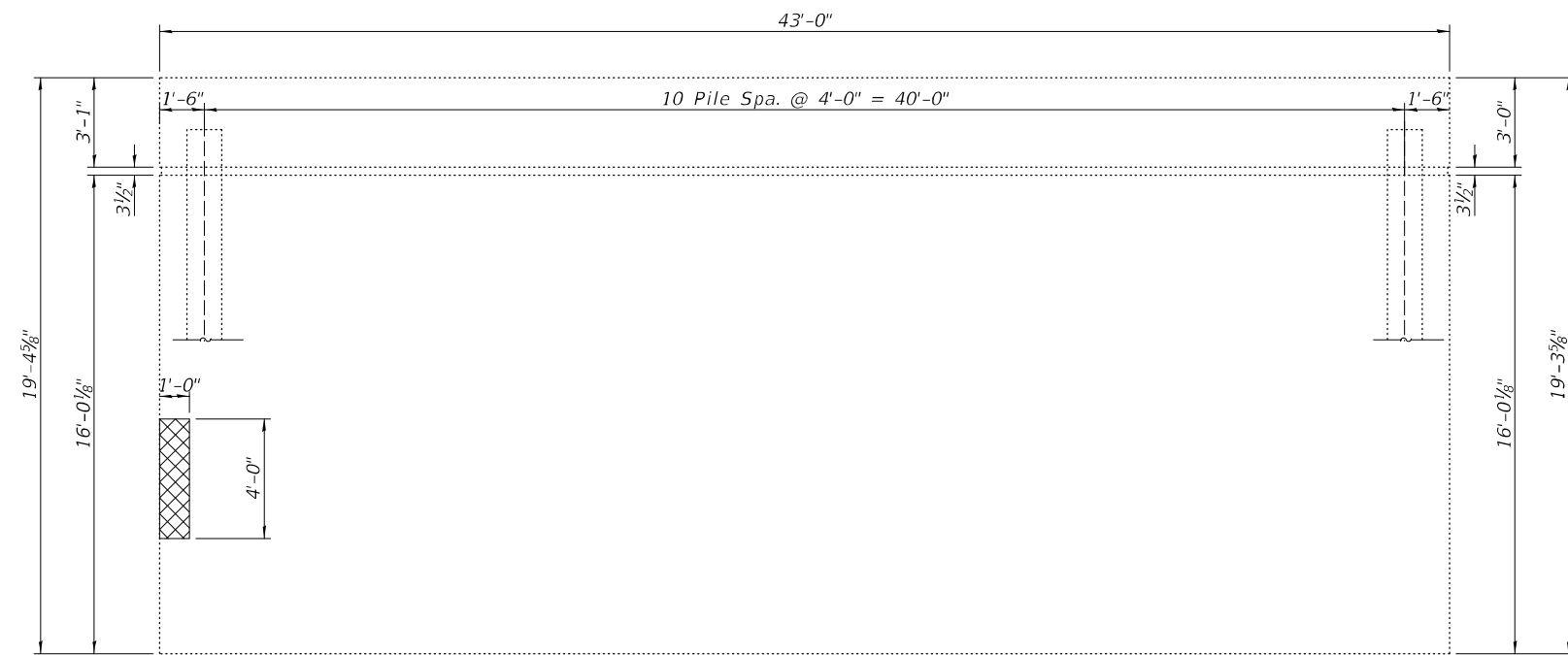

ELEVATION
(Looking West)

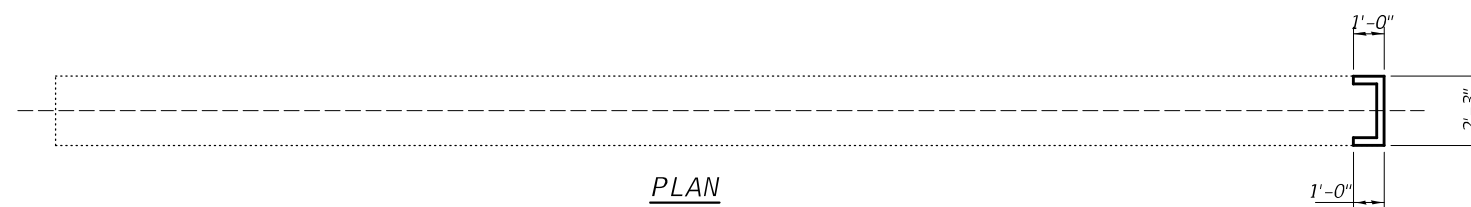

PLAN

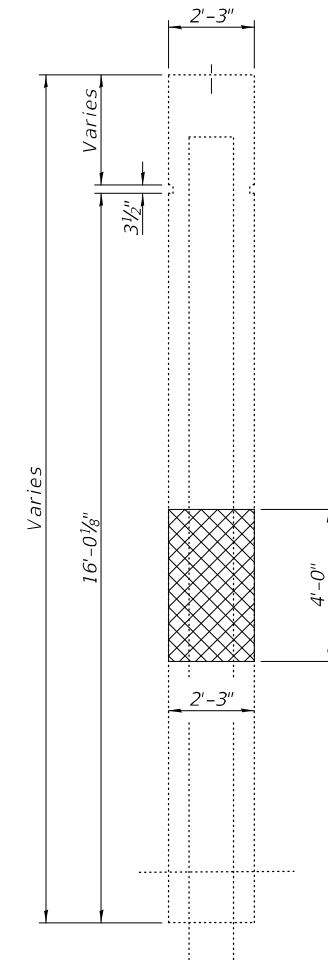

END VIEW-SOUTH SIDE
(Looking North)

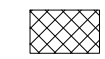
 Structural Repair of Concrete (Depth ≤ 5")

BILL OF MATERIAL

Item	Unit	Quantity
Structural Repair of Concrete (Depth ≤ 5")	Sq. Ft.	17

DESIGNED - ATH
CHECKED - CCC
DRAWN - Venkat Ramana Reddy
CHECKED - ATH CCC

PASSED

ENGINEER OF BRIDGES AND STRUCTURES

DATE - February 2, 2023

REVISED -
REVISED -

STATE OF ILLINOIS
DEPARTMENT OF TRANSPORTATION

PIER 2 REPAIR DETAILS
SN 086-0043 (WB)

SHEET NO. 7 OF 15 SHEETS

F.A.I. RTE.	SECTION	COUNTY	TOTAL SHEETS	SHEET NO.
72	(86-8) BDR1,BJR1,BRR1,BP	SCOTT	45	40
ILLINOIS			FED. AID PROJECT	

CONTRACT NO. 72136

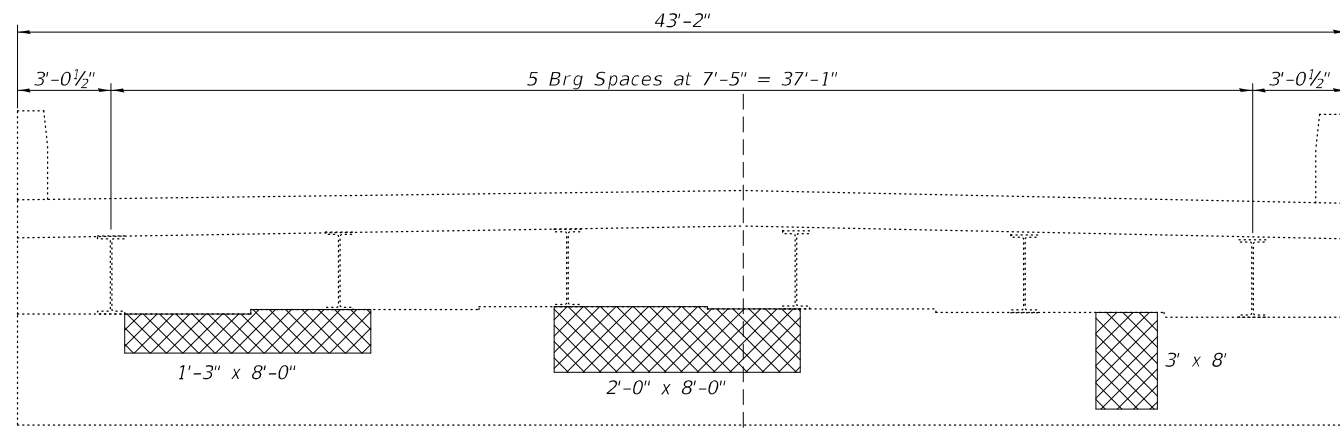

E. ABUT. ELEVATION
(Looking East)

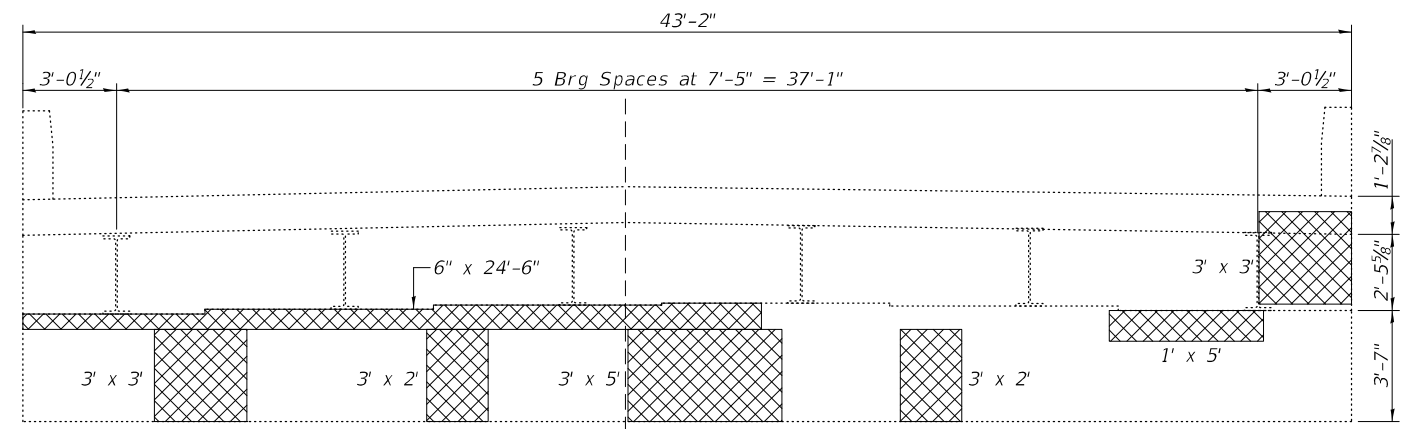

W. ABUT. ELEVATION
(Looking West)

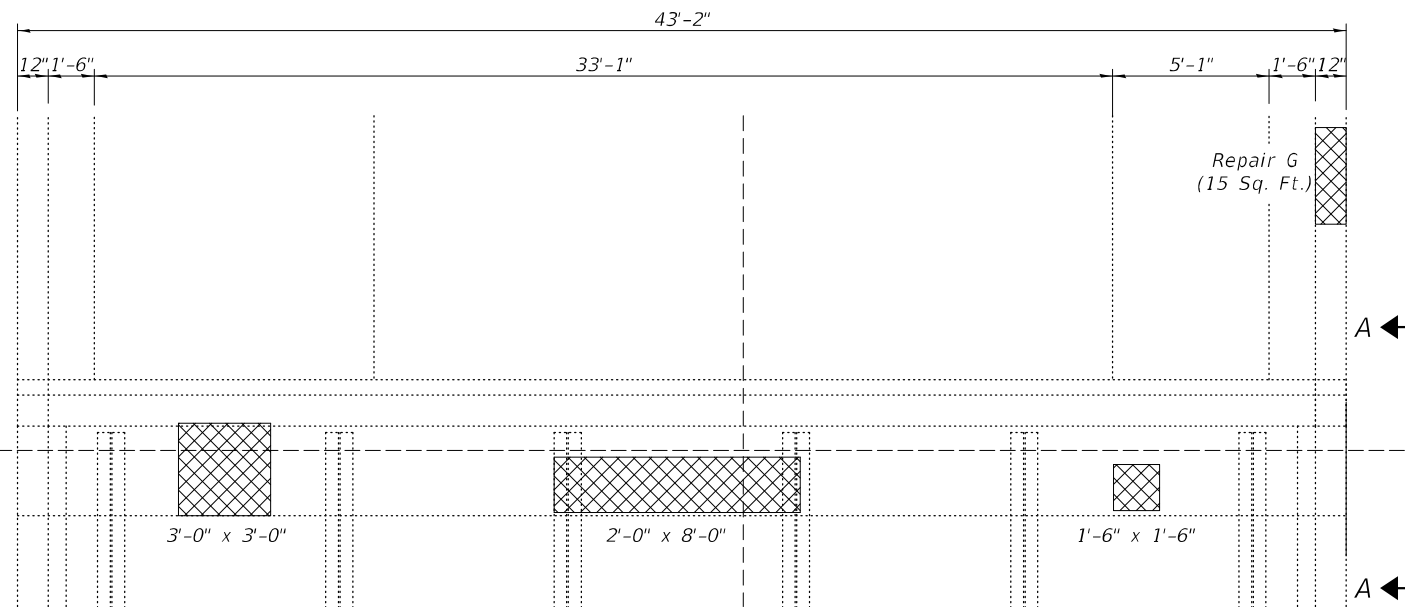

E. ABUT. PLAN

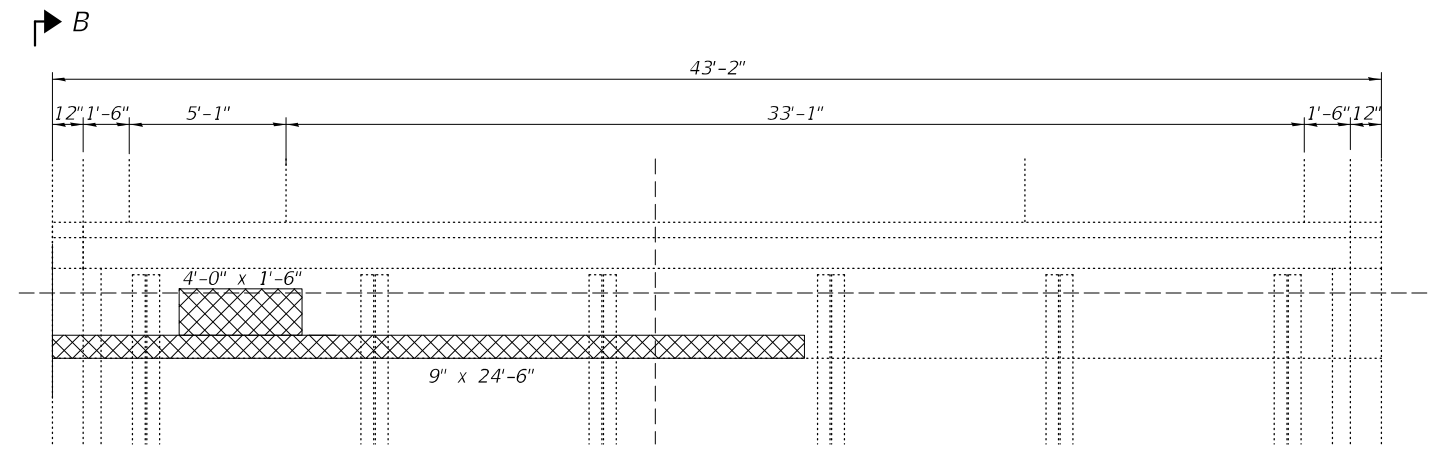

W. ABUT. PLAN

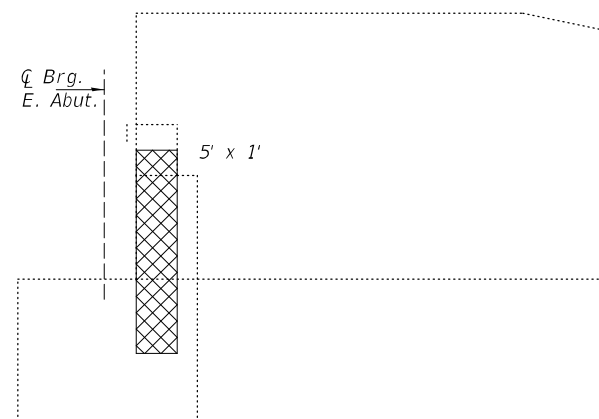

SECTION A-A

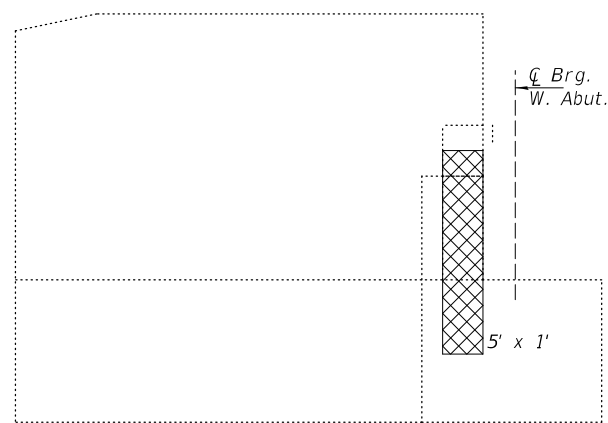

SECTION B-B

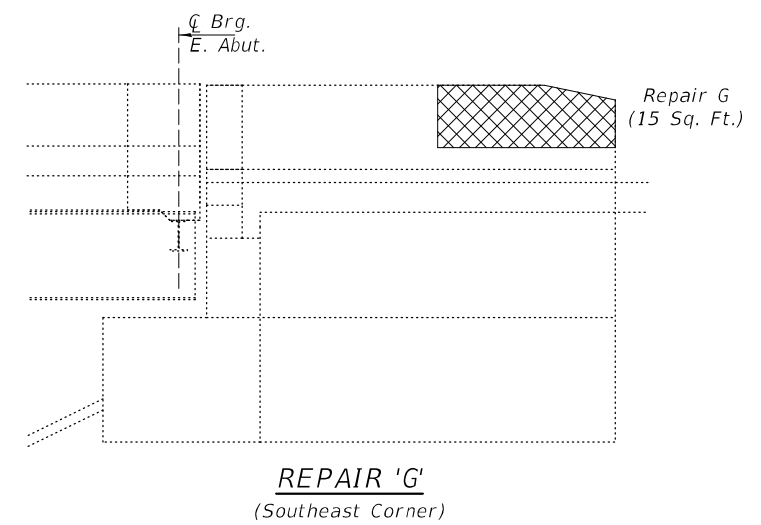

REPAIR 'G'
(Southeast Corner)

Structural Repair of Concrete (Depth ≤ 5")

BILL OF MATERIAL

Item	Unit	Quantity
Structural Repair of Concrete (Depth ≤ 5")	Sq. Ft.	189

DESIGNED - ATH
CHECKED - CCC
DRAWN - Venkat Ramana Reddy
CHECKED - ATH CCC

PASSED

Joanna F. [Signature]
ENGINEER OF BRIDGES AND STRUCTURES

DATE - February 2, 2023

REVISED -
REVISED -

STATE OF ILLINOIS
DEPARTMENT OF TRANSPORTATION

ABUTMENTS REPAIR DETAILS
SN 086-0043 (WB)

SHEET NO. 8 OF 15 SHEETS

F.A.I. RTE.	SECTION	COUNTY	TOTAL SHEETS	SHEET NO.
72	(86-8) BDR1,BJR1,BRR1,BP	SCOTT	45	41
CONTRACT NO. 72136				
ILLINOIS FED. AID PROJECT				

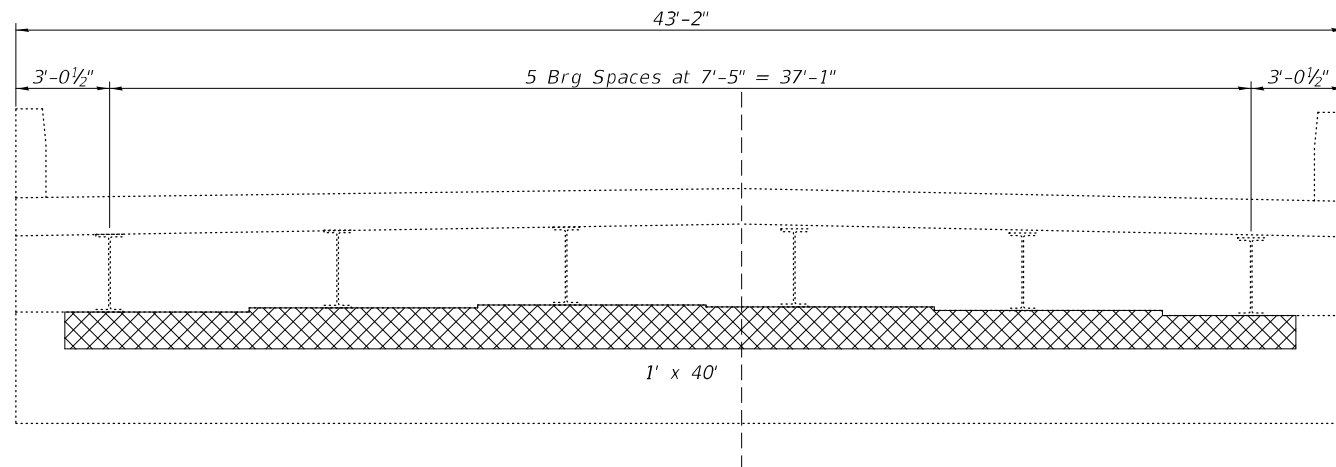

W. ABUT. ELEVATION

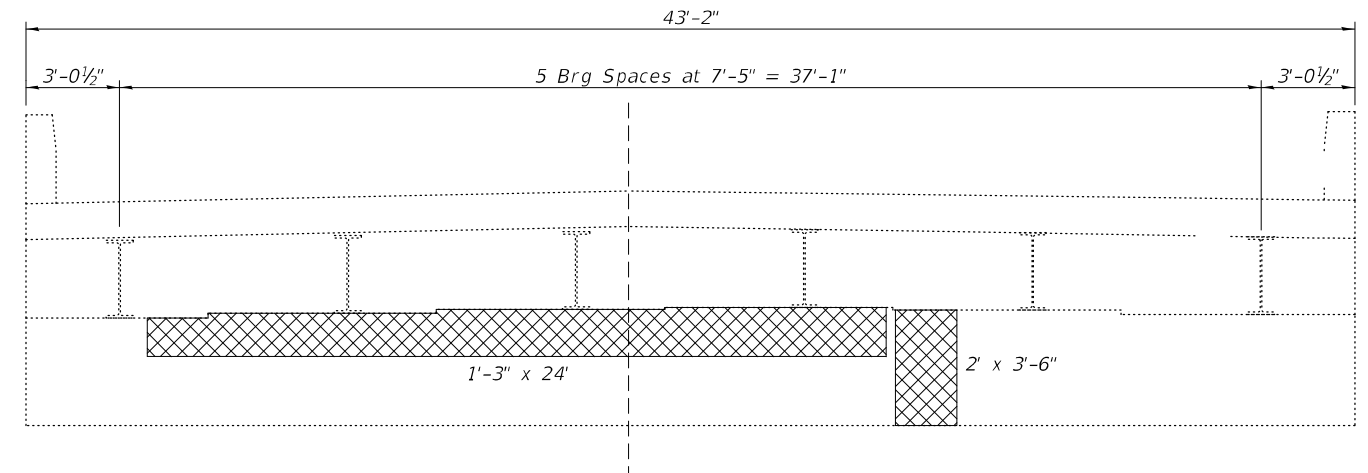

E. ABUT. ELEVATION

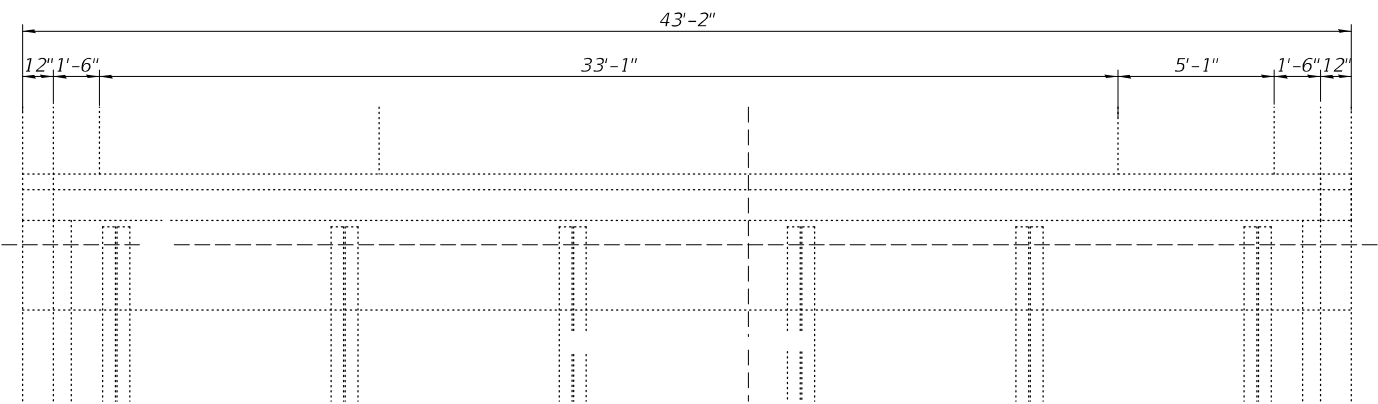

W. ABUT. PLAN

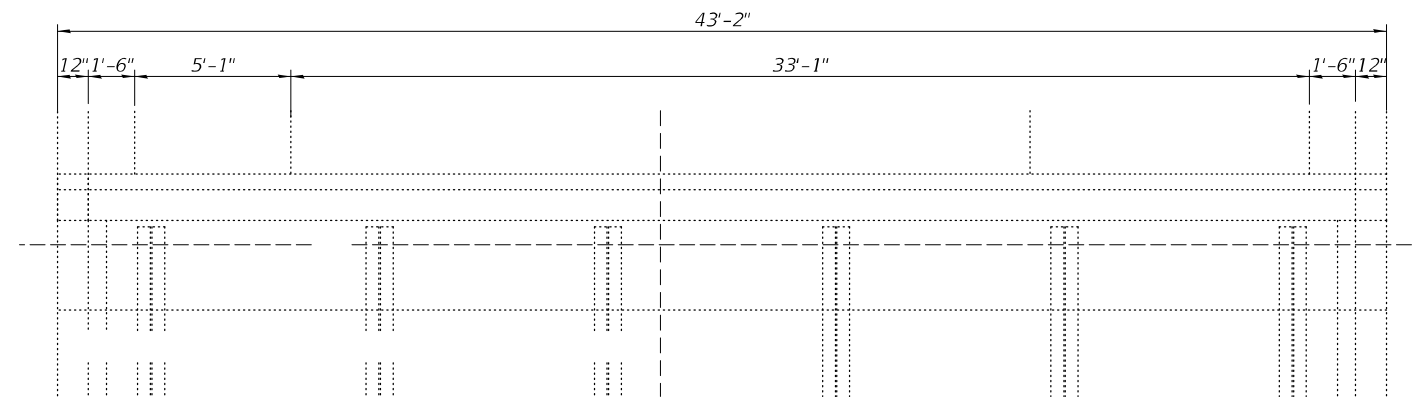

E. ABUT. PLAN

 Structural Repair of Concrete (Depth ≤ 5")

BILL OF MATERIAL

Item	Unit	Quantity
Structural Repair of Concrete (Depth ≤ 5")	Sq. Ft.	77

DESIGNED - ATH
 CHECKED - CCC
 DRAWN - Venkat Ramana Reddy
 CHECKED - ATH CCC

PASSED

 ENGINEER OF BRIDGES AND STRUCTURES

DATE - February 2, 2023

REVISED -
 REVISED -

**STATE OF ILLINOIS
 DEPARTMENT OF TRANSPORTATION**

**ABUTMENTS REPAIR DETAILS
 SN 086-0042 (EB)**

SHEET NO. 9 OF 15 SHEETS

F.A.I. RTE.	SECTION	COUNTY	TOTAL SHEETS	SHEET NO.
72	(86-8) BDR1,BJR1,BRR1,BP	SCOTT	45	42
CONTRACT NO. 72136				
ILLINOIS FED. AID PROJECT				

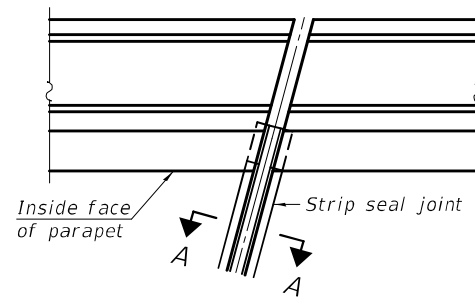

FOR SKEWS $\leq 30^\circ$
PLAN AT PARAPET

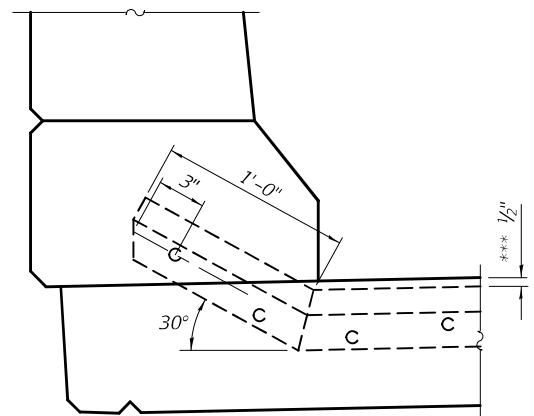

PARAPET ELEVATION AT ABUTMENTS
 (Skews $\leq 30^\circ$)

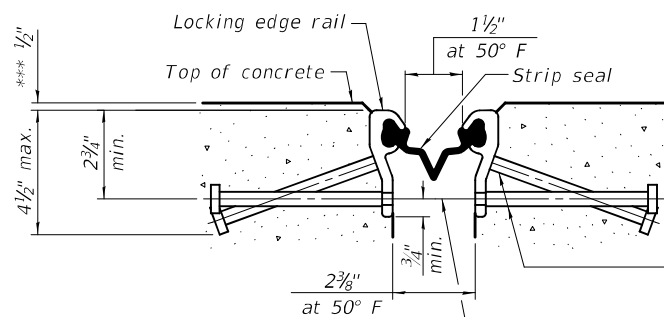

SHOWING ROLLED RAIL JOINT

* $\frac{5}{8}$ " ϕ x 6" studs @ 6" cts. (alternate angled/bent studs with horizontal studs)
 $\frac{3}{8}$ " ϕ threaded rods in $\frac{1}{16}$ " ϕ holes at ± 4 "-0" cts. for holding the proper joint opening based on the temperature during the deck pour. Place to miss studs. All rods shall be burned, or sawed off flush with the plates after concrete is set.

SECTION A-A

* Granular or solid flux filled headed studs conforming to Article 1006.32 of the Std. Specs., automatically end welded.

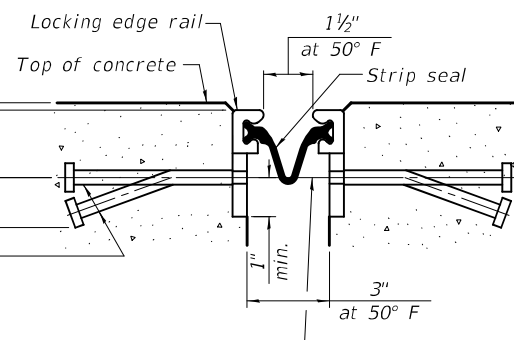

SHOWING WELDED RAIL JOINT

***Prior to $\frac{1}{4}$ " Grinding

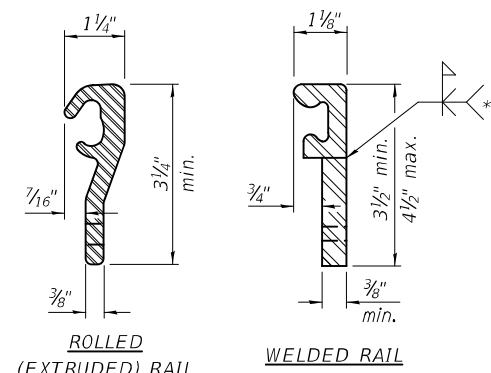

LOCKING EDGE RAILS

** Back gouge not required if complete joint penetration is verified by mock-up.

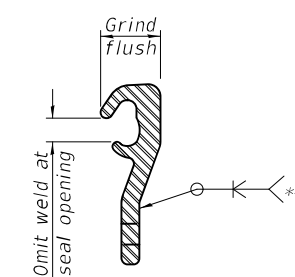

LOCKING EDGE RAIL SPLICE

The inside of the locking edge rail groove shall be free of weld residue. Rolled rail shown, welded rail similar.

BILL OF MATERIAL

Item	Unit	Total
Preformed Joint Strip Seal	Foot	168

Notes:
 The strip seal shall be made continuous and shall have a minimum thickness of $\frac{1}{4}$ ". The configuration of the strip seal shall match the configuration of the locking edge rails. Open or "webbed" strip seal gland configurations are not permitted. The gland shall be sized for a maximum rated movement of 4 inches.
 The locking edge rails depicted are configured for typical applications and are conceptual only. The actual configuration of the locking edge rails and matching strip seal may vary from manufacturer to manufacturer provided they fit the application and meet the minimum anchorage shown. Flanged edge rails, however, will not be allowed. Locking edge rails may exceed the $4\frac{1}{2}$ " maximum depth provided the anchorage system is revised according to the manufacturer's recommendation.
 The manufacturer's recommended installation methods shall be followed.
 All steel components shall be galvanized after fabrication according to Article 520.03 of the Standard Specifications.
 The Maximum space between locking edge rail segments shall be $\frac{3}{16}$ " and sealed with a suitable sealant; however, any rail joint within 10' measured perpendicular to the face of the curb or parapet shall be welded as shown in the locking edge rail splice detail.
 The concrete opening below the strip seal will vary based on the locking edge rail chosen by the Contractor. Deck and parapet lengths shown elsewhere in the plans are dimensioned to the concrete opening, not the joint opening, and are based on the rolled locking edge rail. If the Contractor elects to use a different locking edge rail, dimensional adjustments may be required. One exception to this would be the strip seal joint at the end of the precast bridge approach slab. For these cases the pavement connector length shall be adjusted, not the length of the bridge approach slab.

EJ-SS1 LT30/REPS

2-25-20

DESIGNED - ATH
CHECKED - CCC
DRAWN - Venkat Ramana Reddy
CHECKED - ATH CCC

PASSED

Joanna F. Joffe
 ENGINEER OF BRIDGES AND STRUCTURES

DATE - February 2, 2023

REVISED -
REVISED -

STATE OF ILLINOIS
 DEPARTMENT OF TRANSPORTATION

PREFORMED JOINT STRIP SEAL
 SN 086-0042 (EB) & 0043 (WB)

SHEET NO. 10 OF 15 SHEETS

F.A.I. RTE.	SECTION	COUNTY	TOTAL SHEETS	SHEET NO.
72	(86-8) BDR1,BJR1,BRR1,BP	SCOTT	45	43
CONTRACT NO. 72136				
ILLINOIS FED. AID PROJECT				

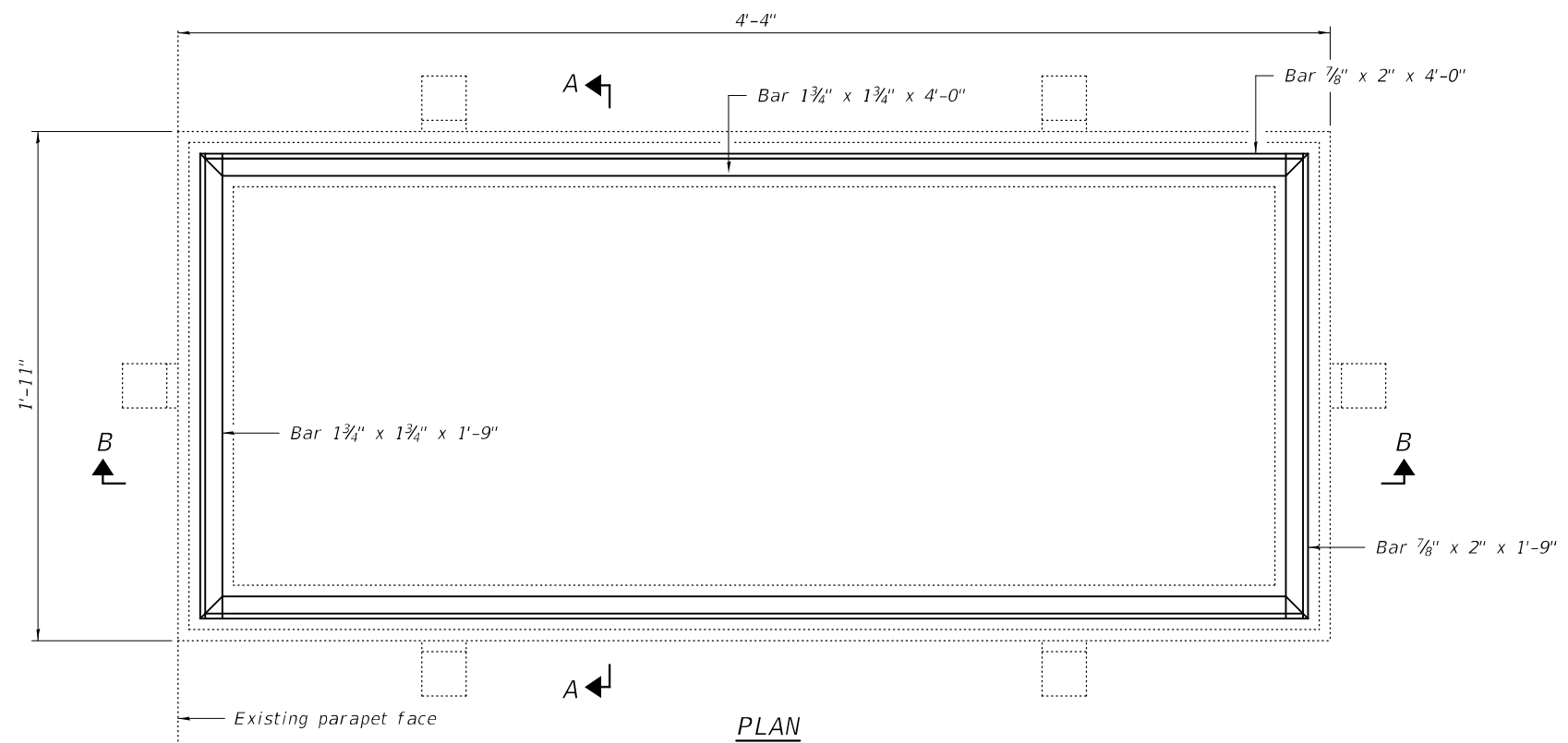

Notes:
 The contractor shall ensure that no damage is done to existing grates to be reused.
 Shop plans for proposed adjusting inlet ring shall be submitted for approval prior to fabrication.
 Cost of all labor and materials necessary to remove existing grates, clean existing inlets, install adjusting inlet rings and reinstalling grates is included in the cost per unit each for Inlets to be Adjusted.
 All structural steel shall conform to AASHTO Classification M-270 Gr. 36.
 The adjusting inlet ring shall be galvanized.
 Bolts shall be 1/2"Ø, AASHTO M164 Type I, mechanically galvanized.

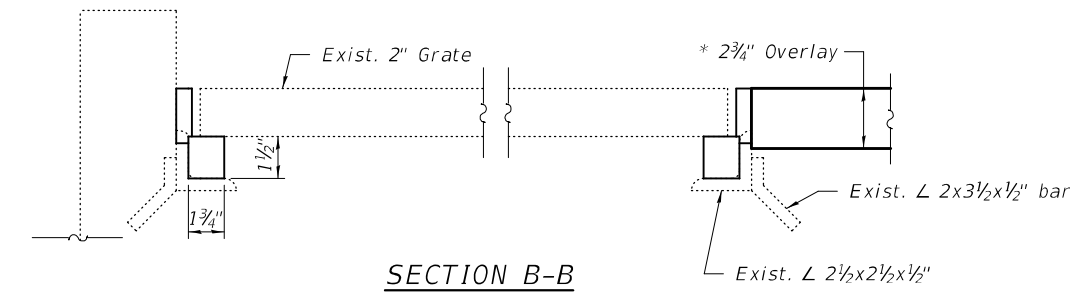
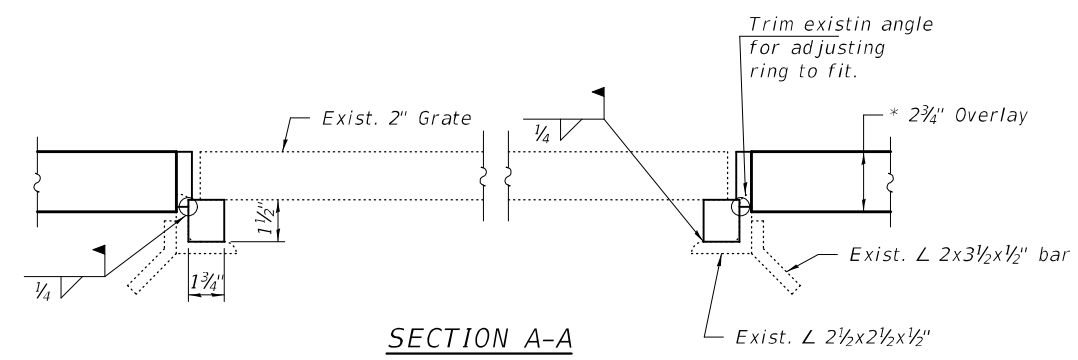

* Prior to grinding

BILL OF MATERIAL

Item	Unit	Total
Inlets to be Adjusted	Each	8

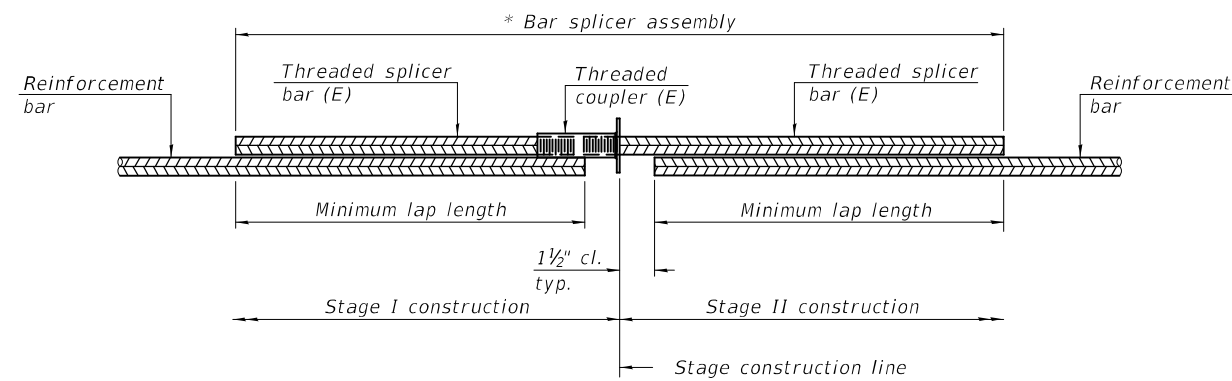

STANDARD BAR SPLICER ASSEMBLY PLAN
(All components shall be provided from one supplier)

Threaded splicer bar length = min. lap length + 1 1/2" + thread length

* Epoxy not required on Bar Splicer Assembly components used in conjunction with black bars.

Location	Bar size	No. assemblies required	Minimum lap length
Deck	#5	32	3'-6"
Abutment	#6	16	4'-0"

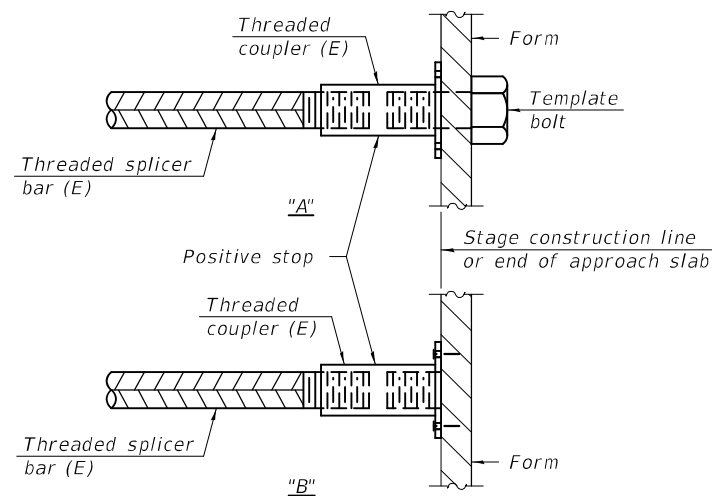

INSTALLATION AND SETTING METHODS

"A" : Set bar splicer assembly by means of a template bolt.

"B" : Set bar splicer assembly by nailing to wood forms or cementing to steel forms.

(E) : Indicates epoxy coating.

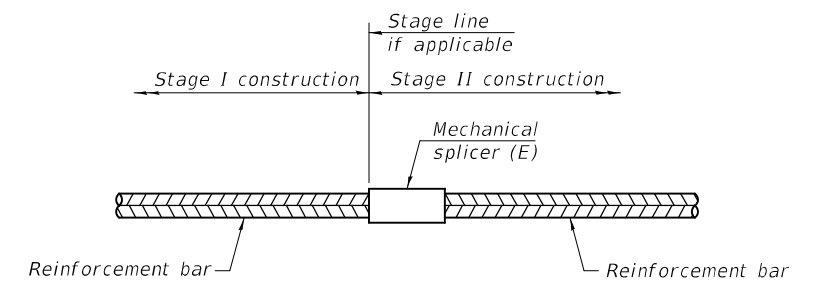

STANDARD MECHANICAL SPLICER

Location	Bar size	No. assemblies required

Notes:

Splicer bars shall be deformed with threaded ends and have a minimum 60 ksi yield strength.

All reinforcement shall be lapped and tied to the splicer bars.

Bar splicer assemblies shall be epoxy coated according to the requirements for reinforcement bars. See Section 508 of the Standard Specifications.

See approved list of bar splicer assemblies and mechanical splicers for alternatives.

BSD-1

1-1-2020

DESIGNED - ATH
CHECKED - CCC
DRAWN - Venkat Ramana Reddy
CHECKED - ATH CCC

PASSED

Jaime F. Joffe
ENGINEER OF BRIDGES AND STRUCTURES

DATE - February 2, 2023

REVISED -
REVISED -

STATE OF ILLINOIS
DEPARTMENT OF TRANSPORTATION

BAR SPLICER ASSEMBLY AND MECHANICAL SPLICER DETAILS
SN 086-0042 (EB) & 0043 (WB)

SHEET NO. 11 OF 15 SHEETS

F.A.I. RTE.	SECTION	COUNTY	TOTAL SHEETS	SHEET NO.
72	(86-8) BDR1,BJR1,BRR1,BP	SCOTT	45	45
CONTRACT NO. 72136			ILLINOIS FED. AID PROJECT	

STATE OF ILLINOIS
DEPARTMENT OF TRANSPORTATION

ROUTE NO.	SECTION	COUNTY	TOTAL SHEETS	SHEET NO.	SHEET NO. 9
86-8B-1	SCOTT	176	53	10	10 SHEETS

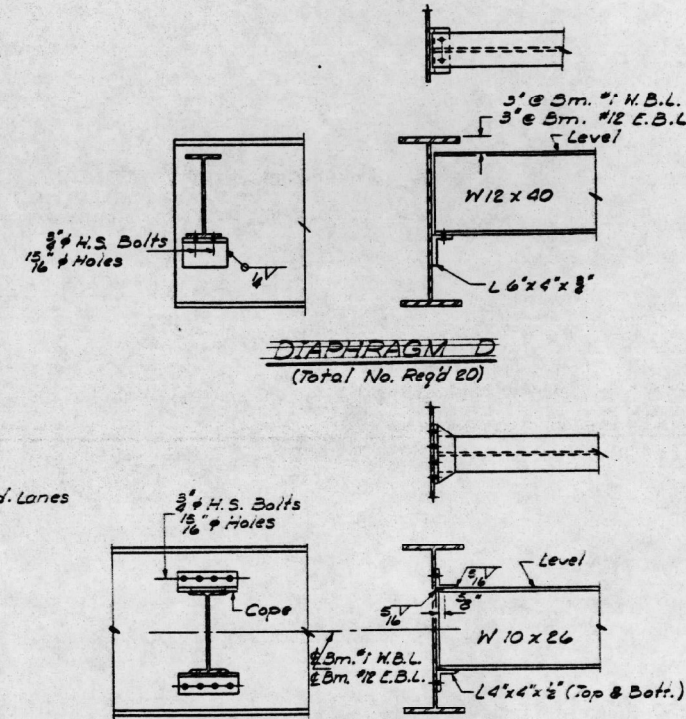
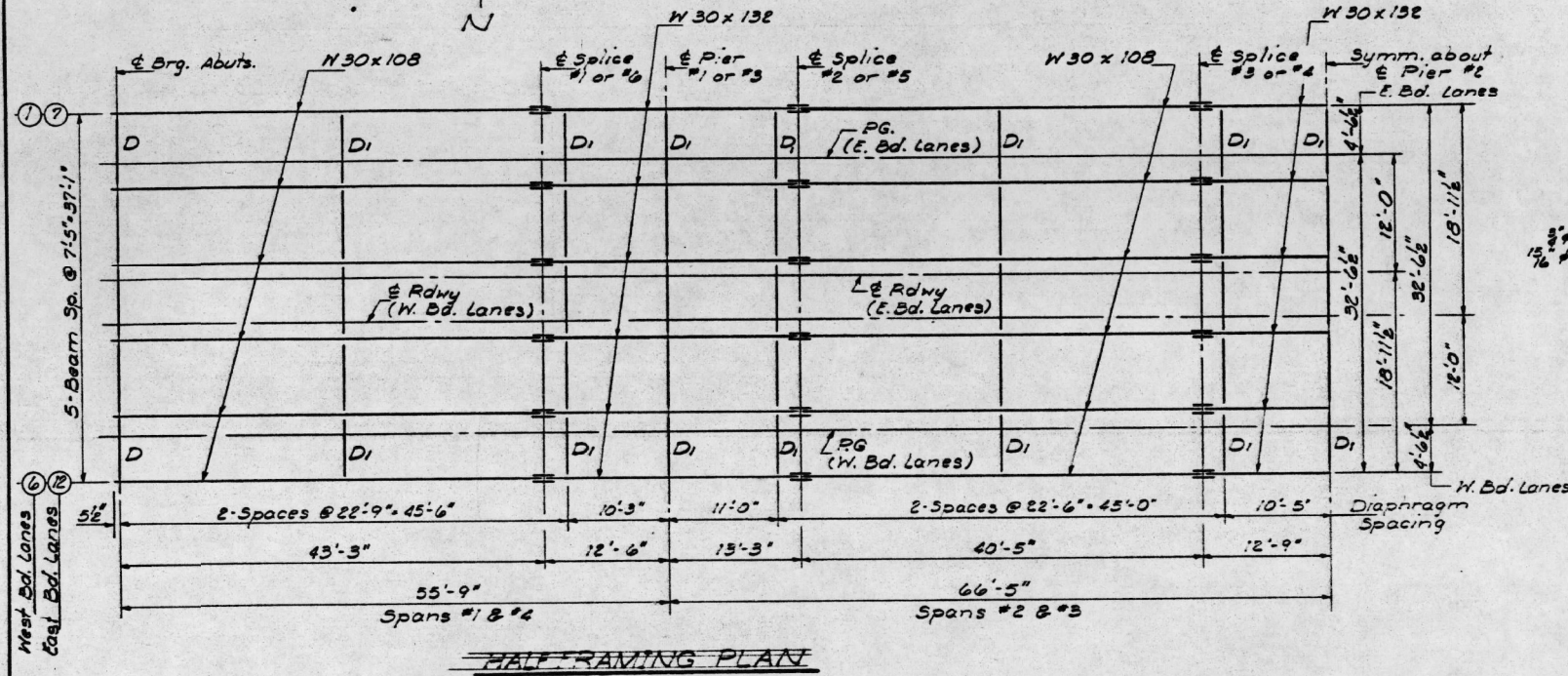

Notes:
Hardened washers shall be required over all 1/8" holes.

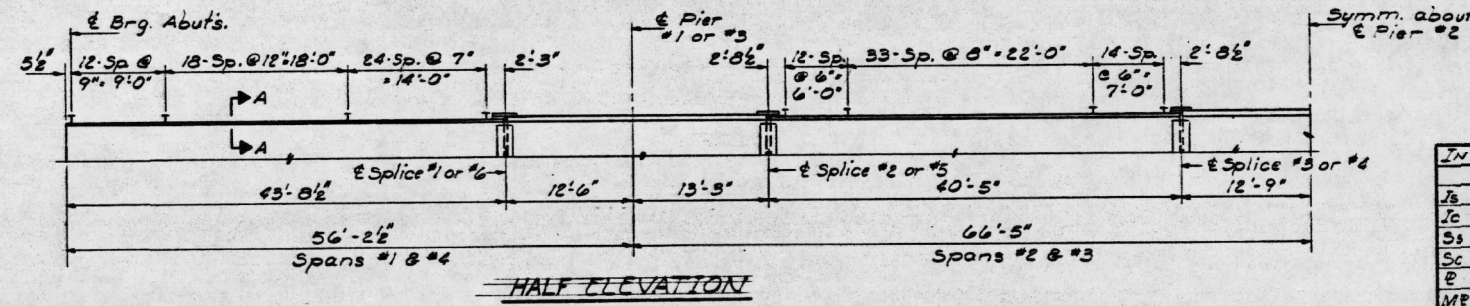

INTERIOR W BEAM MOMENT TABLE

	4 Sp/184 Piers	5 Sp/283 Piers	Pier E
I_b (in ⁴)	4470	5770	4470
I_c (in ⁴)	12125	12125	12125
S_b (in ³)	299	380	299
S_c (in ³)	440	440	440
Q (k/ft)	.831	.833	.836
M_B (k)	228.2	437.1	176.7
M_E (k)	9.2	13.8	7.1
S_R (k/ft)	.320	.320	.320
M_{sB} (k)	103.8	128.5	99.5
M_{sE} (k)	905.2	551.2	937.1
M_{imp} (k)	250.5	148.2	244.6
TOTAL (k)	1259.5	827.9	1281.0
f_s comp. (ksi)	34.4	26.1	34.9
f_s TOTAL (ksi)	45.6	39.9	42.0
V_R (k)	54.7	46.9	

TOP OF FLANGE ELEVATIONS*

Span	Loc. Elev. 'A'	Elev. 'B'
#1 @ #2	446.07	446.09
#2 @ #3	446.25	446.25
#3 @ #4	446.35	446.37
#4 @ #5	446.41	446.43
#5 @ #6	446.50	446.52
#6 @ #7	446.16	446.18

Elev. 'A' @ E Brg West & East Abutments.
Elev. 'B' @ E Splices thru #6 & Piers #1, #2 & #3.
Elevations at splice are for top of W 30 x 132 flange.
* For fabrication only.

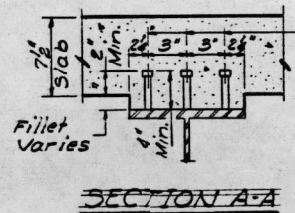

3" Granular or solid flux filled headed studs automatically end welded (Total No. Req'd=8280)

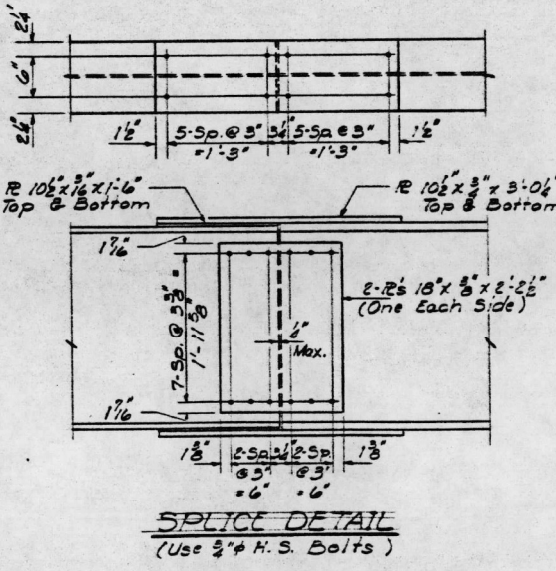

INTERIOR W.B.M. REACTION TABLE

	Abuts	Piers 1&3	Pier E
R_B (k)	24.5	78.6	76.2
R_E (k)	59.2	48.0	49.1
R_{imp} (k)	10.8	12.9	12.8
TOTAL (k)	74.5	139.5	138.1

I_b and S_b are the moment of inertia and section modulus of the steel section used in computing f_s TOTAL.
 I_c and S_c are the moment of inertia and section modulus of the composite section used in computing f_s TOTAL.
 V_R is the maximum \pm impact shear range in span used to determine shear connector spacing.
The Load Factor 1.3 [2 + 3/5 (E + 2)] is used for computing moments and stresses.
Values given in Reaction tables are based upon service load.

FOR INFORMATION ONLY

W 30 & E 30 LANES
STRUCTURAL STEEL
F.A. RT. 408 SEC. 86-8B-1
SCOTT COUNTY
STA. 45+38

DESIGNED Adh. Shenouda
CHECKED ALEX SINDVLA
DRAWN J. SCHNELLER
CHECKED Adh. Shenouda

EXAMINED
PASSED
APPROVED

JUNE 3 1980

Revised 3-31-86 ALC

STATE OF ILLINOIS
DEPARTMENT OF TRANSPORTATION

ROUTE NO.	SECTION	COUNTY	TOTAL SHEETS	SHEET NO.	SHEET NO. 10
408	86-BB-1	Scott	176	54	16 SHEETS
PREPARED BY: DATE: FOR AND PROJECT:					

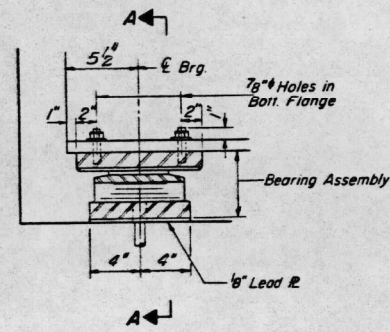

SECTION AT ABUTS.

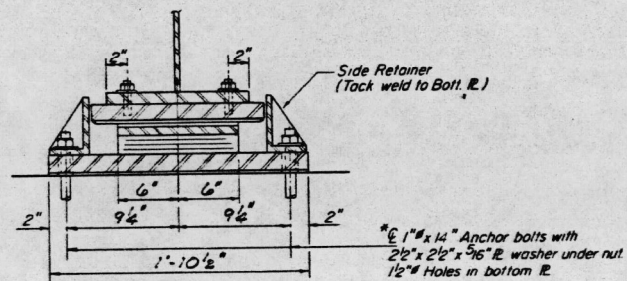

SECTION A-A

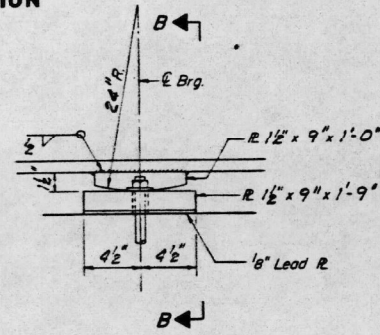

ELEVATION AT PIERS
#1, #2 & #3

FIXED BEARING

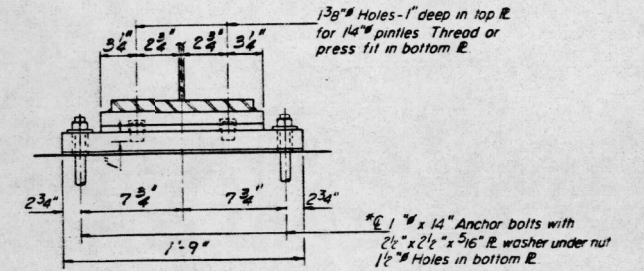

SECTION B-B

TYPE II TFE ELASTOMERIC EXP. BRG.

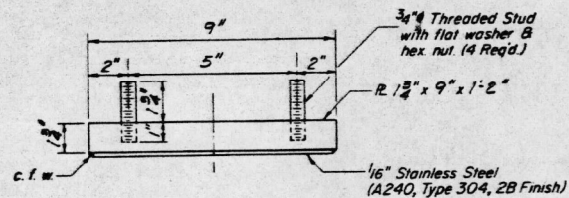

TOP BEARING ASSEMBLY

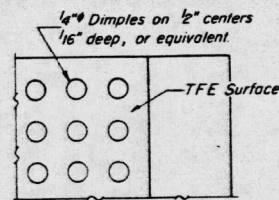

PLAN-TFE SURFACE

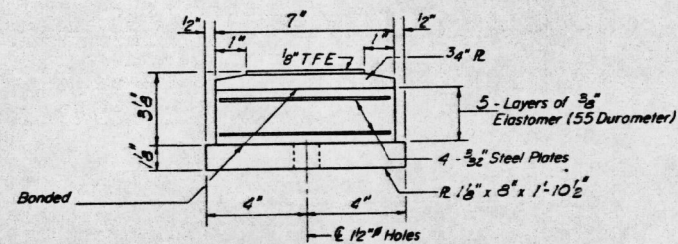

BOTTOM BEARING ASSEMBLY

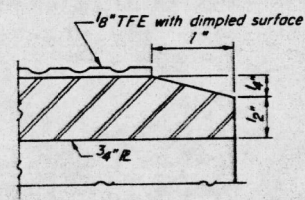

SECTION THRU TFE

*Note:
Anchor bolts of fixed bearings may be built into the masonry.
See sheet #16 of 16 for anchor bolt installation.

Note:
Unless otherwise specified all Structural Steel shapes and plates shall conform to AASHTO M-222 material requirements.

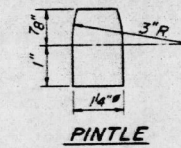

PINTLE

Note. The 1/8" TFE sheet shall be bonded directly to the top steel plate with a two-component, medium viscosity epoxy resin, conforming to the requirements of the Federal Specification MMM-A-134, Type I. The bond agent shall be applied on the full area of the contact surfaces.

Bonding of 1/8" TFE sheet during vulcanizing process will be permitted provided the process and method of adjusting assembly height is approved by the Engineer.

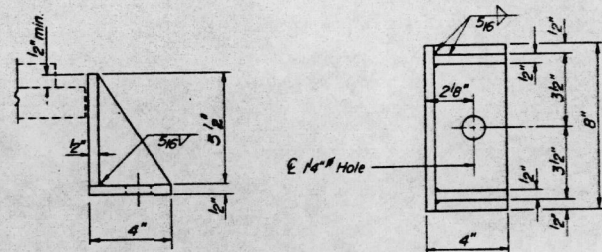

SIDE RETAINER

Equivalent rolled angle with stiffeners will be allowed in lieu of welded plates. (4B Required)

DESIGNED ALEX SINDVLA	EXAMINED	JUN 5 3 1980
CHECKED Adli Sheenola	PASSED	
DRAWN J. SCHNELLER	APPROVED	
CHECKED ALEX SINDVLA	DIRECTOR OF HIGHWAYS	

I-2-E2 4-1-79

Revised JTB/ALC

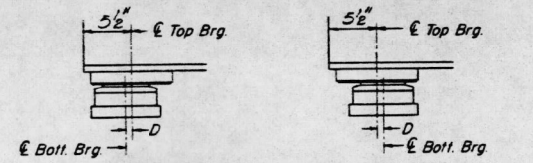

BELOW 50°F (Move bott brg. away from fixed brg.) ABOVE 50°F (Move bott. brg. toward fixed brg.)

SETTING ANCHOR BOLTS AT EXP. BRG.

D = 1/8" per each 100' of expansion for every 15° temp. change from the normal temp. of 50°F

FOR INFORMATION ONLY

BEARING DETAILS
F.A. RT. 408 SEC. 86-BB-1
SCOTT COUNTY
STA. 45+38

DESIGNED - ATH
CHECKED - CCC
DRAWN - Venkat Ramana Reddy
CHECKED - ATH CCC

PASSED

Joanne F. [Signature]
ENGINEER OF BRIDGES AND STRUCTURES

DATE - February 2, 2023

REVISED -
REVISED -

STATE OF ILLINOIS
DEPARTMENT OF TRANSPORTATION

EXISTING PLAN SHEET - FOR INFORMATION ONLY
SN 086-0042 (EB) & 0043 (WB)

SHEET NO. 14 OF 15 SHEETS

F.A.I. RTE.	SECTION	COUNTY	TOTAL SHEETS	SHEET NO.
72	(86-8) BDR1,BJR1,BRR1,BP	SCOTT	45	45B
CONTRACT NO. 72136				
ILLINOIS / FED. AID PROJECT				

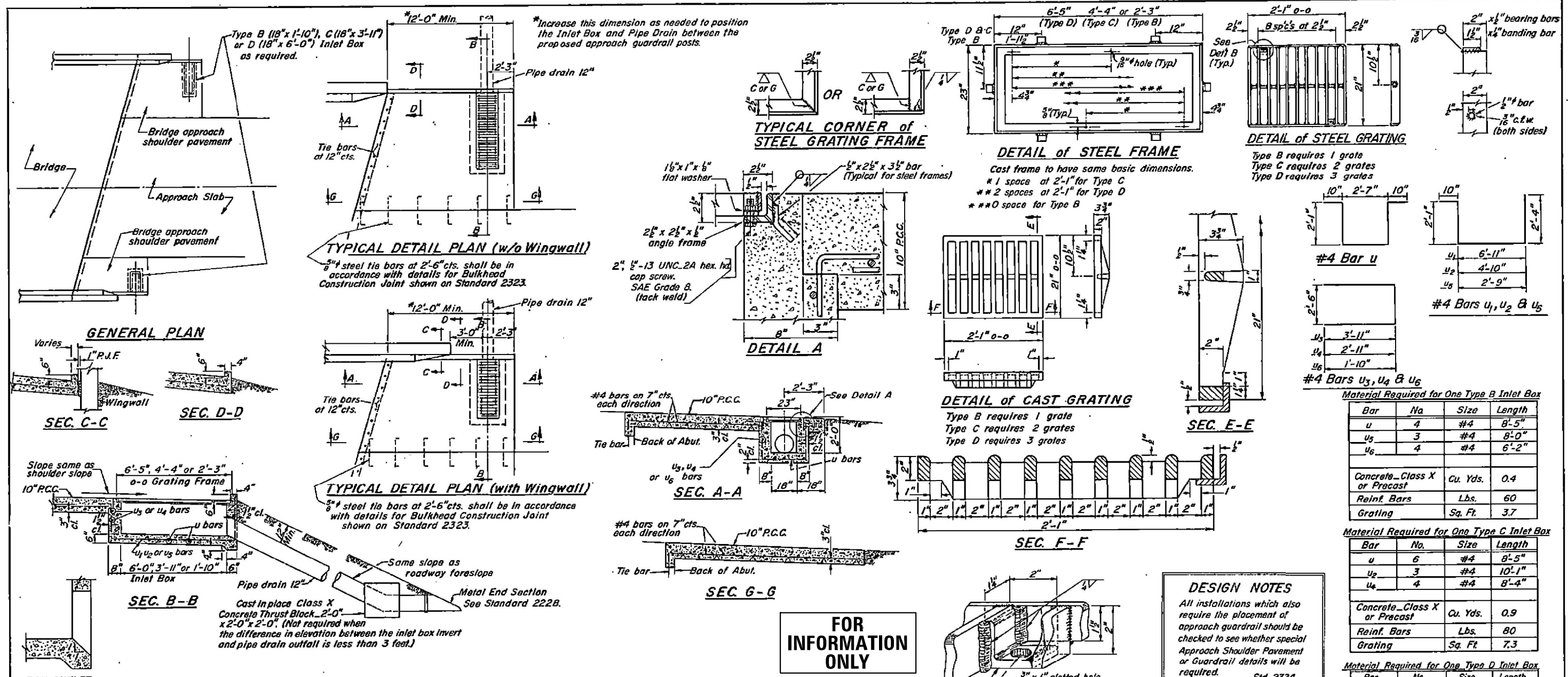

DESIGN NOTES
 All installations which also require the placement of approach guardrail should be checked to see whether special Approach Shoulder Pavement or Guardrail details will be required. Sid. 2324
 Design note will not appear in the contract plans.

Material Required for One Type B Inlet Box

Bar	No.	Size	Length
u	4	#4	8'-5"
u ₅	3	#4	8'-0"
u ₆	4	#4	6'-2"
Concrete - Class X or Precast		Cu. Yds.	0.4
Reinf. Bars		Lbs.	60
Grating		Sq. Ft.	3.7

Material Required for One Type C Inlet Box

Bar	No.	Size	Length
u	6	#4	8'-5"
u ₂	3	#4	10'-1"
u ₄	4	#4	8'-4"
Concrete - Class X or Precast		Cu. Yds.	0.9
Reinf. Bars		Lbs.	80
Grating		Sq. Ft.	7.3

Material Required for One Type D Inlet Box

Bar	No.	Size	Length
u	8	#4	8'-5"
u ₁	3	#4	12'-2"
u ₃	4	#4	10'-4"
Concrete - Class X or Precast		Cu. Yds.	1.2
Reinf. Bars		Lbs.	100
Grating		Sq. Ft.	11.0

FOR INFORMATION ONLY

The lengths of #4 bars used in the approach shoulder pavement shall be as required to accommodate the length, width and skew of the slab.
 Class X concrete or precast concrete shall be used for the inlet. Precast concrete shall be in accordance with Sections 505.01 thru 505.05 of the Standard Specifications except that the concrete strength shall be 4000 p.s.i. after 28 days.
 All exposed edges of the inlet, except the upper perimeter, shall be beveled 3/4".
 Shop drawings will not be required for precast Inlet Boxes. A 3" deep CA-12 bedding conforming to Article 704.01, D Quality or better shall be provided under full length and width of precast units, and all voids around the pipe drain entrance, both inside and outside, shall be sealed with mortar.
 The grating shall seat firmly in the frame and steel grates shall be secured to the frame with a locking device as shown. Cast grates will not require the locking device.
 Steel grating and frames shall conform to Article 710.04 of the Standard Specifications and shall be galvanized to AASHTO Specification M III after fabrication.
 Cast grating and frames shall conform to Article 710.17 of the Standard Specifications. Cast grating and frames shall not be galvanized.

GENERAL NOTES
 When Inlet Box or Boxes are not required, surface of the shoulder pavement shall be finished to provide a smooth transition from back of the abutment to normal approach roadway shoulder.
 See plans for location of bridge approach shoulder pavement. Use Type C Inlet Box for 5' and 6' shoulder widths, use Type D Inlet Box for 7' and wider shoulder widths, use Type B Inlet Box for shoulders less than 5' wide.
 For placement of approach shoulder pavement on existing construction substitute expansion anchor ties for tie bars. For non-rigid approaches, shoulder pavement will be as shown except omit tie bars in approach pavement.
 The material for 12" Pipe Drains shall be either corrugated steel, aluminum alloy or polyethylene (RE.) pipe with UV protection.
 Corrugated steel and aluminum alloy pipe shall have 2' coupling bands. All pipe connections shall be water tight.
 The R.C. Concrete used in the shoulder slab shall meet the requirements of Section 40B of the Standard Specifications.

Illinois Department of Transportation
 PASSED July 18, 1984
 APPROVED July 18, 1984
 ISSUED 12-1-69

BRIDGE APPROACH SHOULDER PAVEMENT
STANDARD 2324-6
 (Full Size)