

STATE OF ILLINOIS  
DEPARTMENT OF TRANSPORTATION

ROUTE NO.	SECTION	COUNTY	SHEETS	SHEET
IL 154		RANDOLPH	5	4
FED. ROAD DIST. NO. 7	ALIGNMENT	FED. AID PROJECT-		

SHEET NO. 3  
4 SHEETS

Contract Number: 76A16

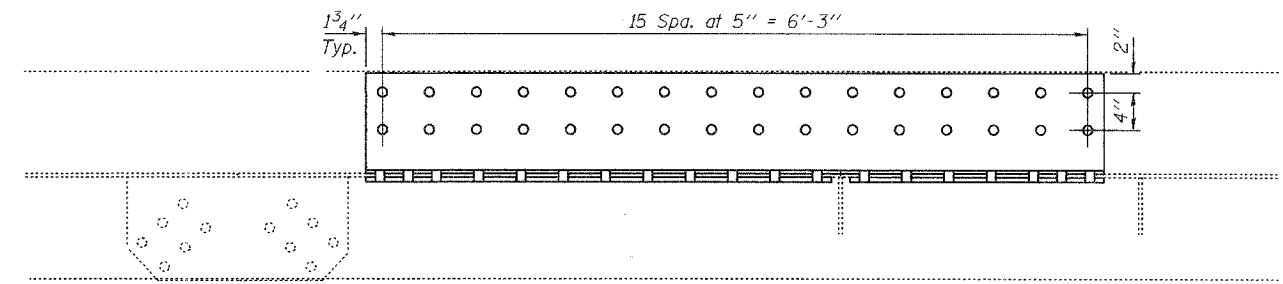
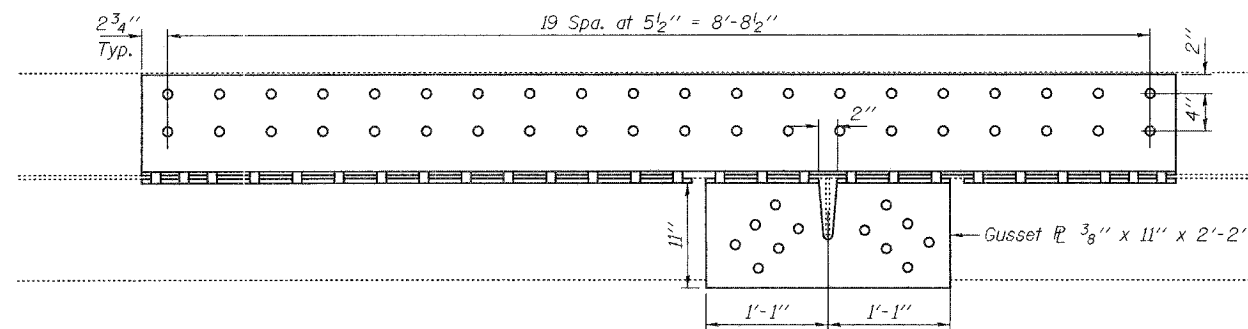
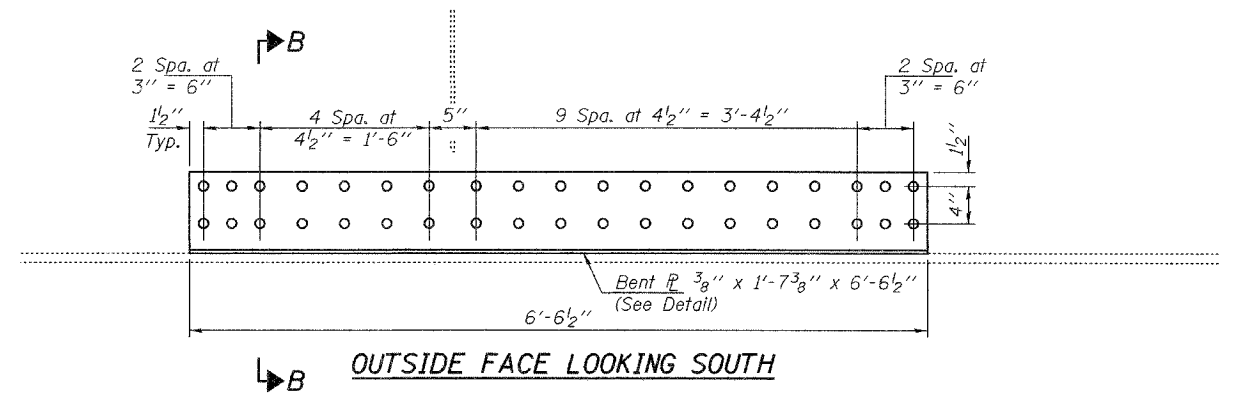
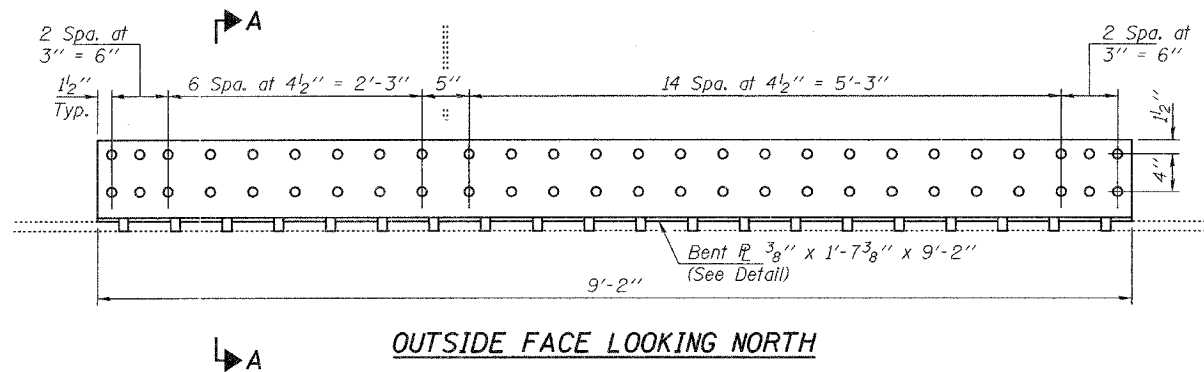
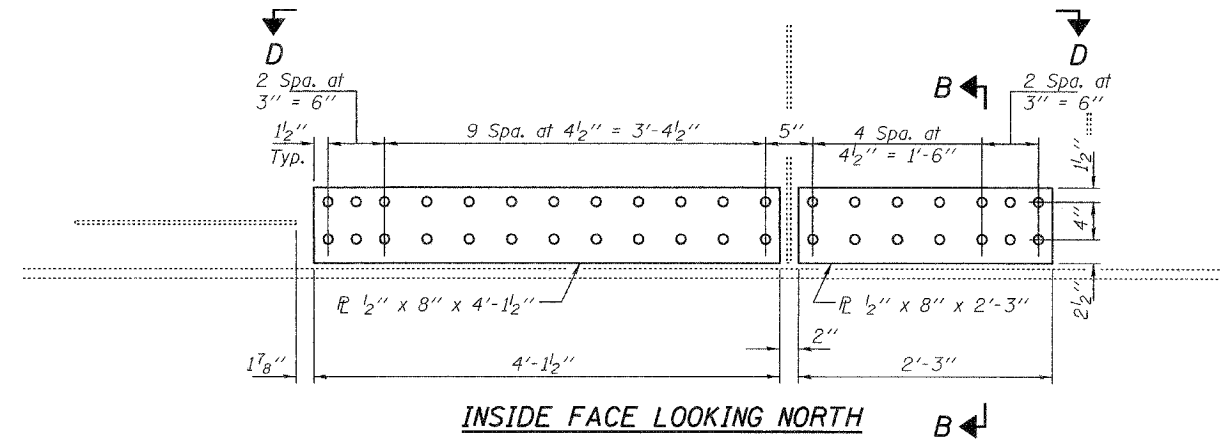
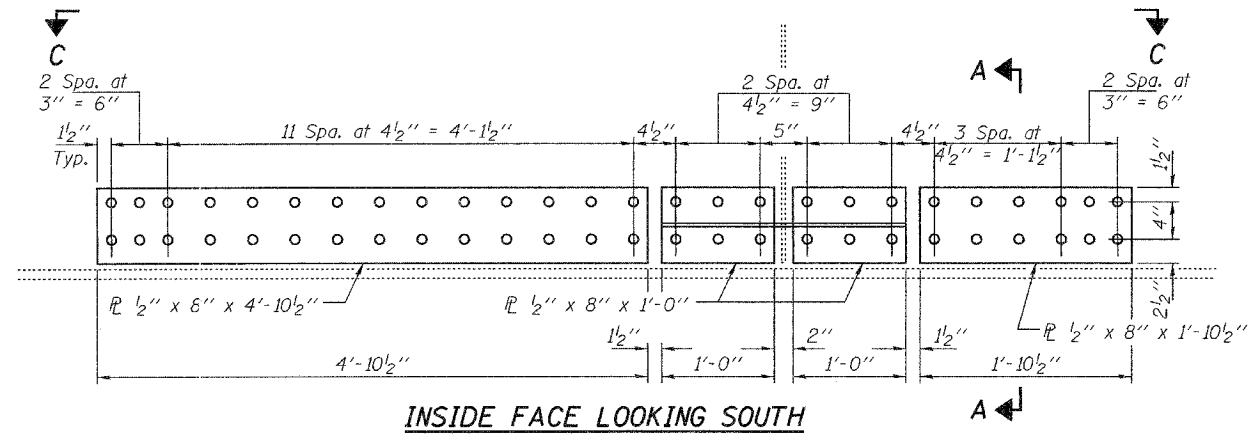

**VIEW C-C**  
**REPAIR A10**  
(1 Required)

**VIEW D-D**  
**REPAIR A11**  
(1 Required)

Notes:  
The Engineer shall field verify the location of repair detail A10 & A11 and ensure that the plate lengths are sufficient to cover the deteriorated areas.  
Use holes in bent  $\bar{P}$  as a template for field drilling holes in existing web and flange.

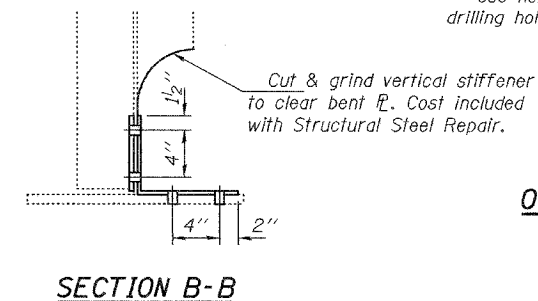
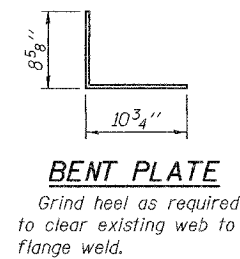
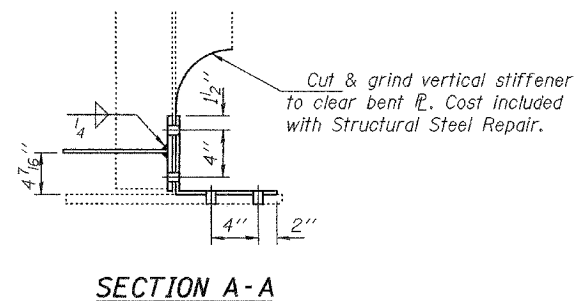

**REPAIR DETAILS**  
**FAP RT. 329 (IL 154)**  
**OVER THE KASKASKIA RIVER**  
**RANDOLPH COUNTY**  
**SN 079-0013**

DESIGNED	SJB
CHECKED	ATH
DRAWN	baliva
CHECKED	SJB ATH

APRIL 27, 2006  
EXAMINED *John A. Morris*  
ENGINEER OF STRUCTURAL SERVICES  
PASSED *Ralph E. Anderson*  
ENGINEER OF BRIDGES AND STRUCTURES