

# STATE OF ILLINOIS DEPARTMENT OF TRANSPORTATION

## PLANS FOR PROPOSED BASSETT SCHOOL ROAD BRIDGE (TR 101C)

ROUTE	SECTION	COUNTY	TOTAL SHEETS	SHEET NO.
TR 101C	12-01162-00-BR	HARDIN	13	1
BASSETT SCHOOL ROAD		CONTRACT 99583		

FUNCTIONAL CLASS: LOCAL ROAD  
ADT (2016): 350  
DESIGN SPEED: 30 MPH

### INDEX TO SHEETS

- 1 COVER
- 2 SUMMARY OF QUANTITIES & TYPICAL SECTION
- 3 GENERAL PLAN & ELEVATION
- 4-5 DECK BEAM DETAILS
- 6 ABUTMENT DETAILS
- 7 STEEL RAILING DETAILS
- 8 PLAN & PROFILE
- 9-11 CROSS SECTIONS
- 12-13 SWPPP

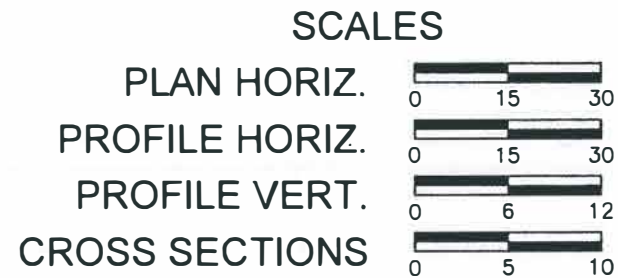

HARDIN COUNTY UNIT ROAD DISTRICT  
SECTION NO. 12-01162-00-BR  
PROJECT NO. S85C(370)  
JOB NO. C-99-507-17  
CONTRACT NO. 99583

STANDARDS IN SPECIAL PROVISIONS

280001-07	TEMP EROSION CONTROL SYSTEMS
515001-03	NAME PLATE FOR BRIDGES
701901-07	TRAFFIC CONTROL DEVICES
725001-01	OBJECT AND TERMINAL MARKERS
BLR 21-9	TYPICAL TRAFFIC CONTROL DEVICES

ALL EXISTING UTILITIES AND LOCATIONS  
TO BE CONFIRMED BY J.U.L.I.E.  
800-892-0123



*Jim W. Brown* 3/15/18  
Date: \_\_\_\_\_

Jim W. Brown as President of Brown & Roberts, Inc.  
Illinois Professional Design Firm  
Land Survey & Prof. Eng. Corp  
Number 184-002518  
Expires April 30, 2019

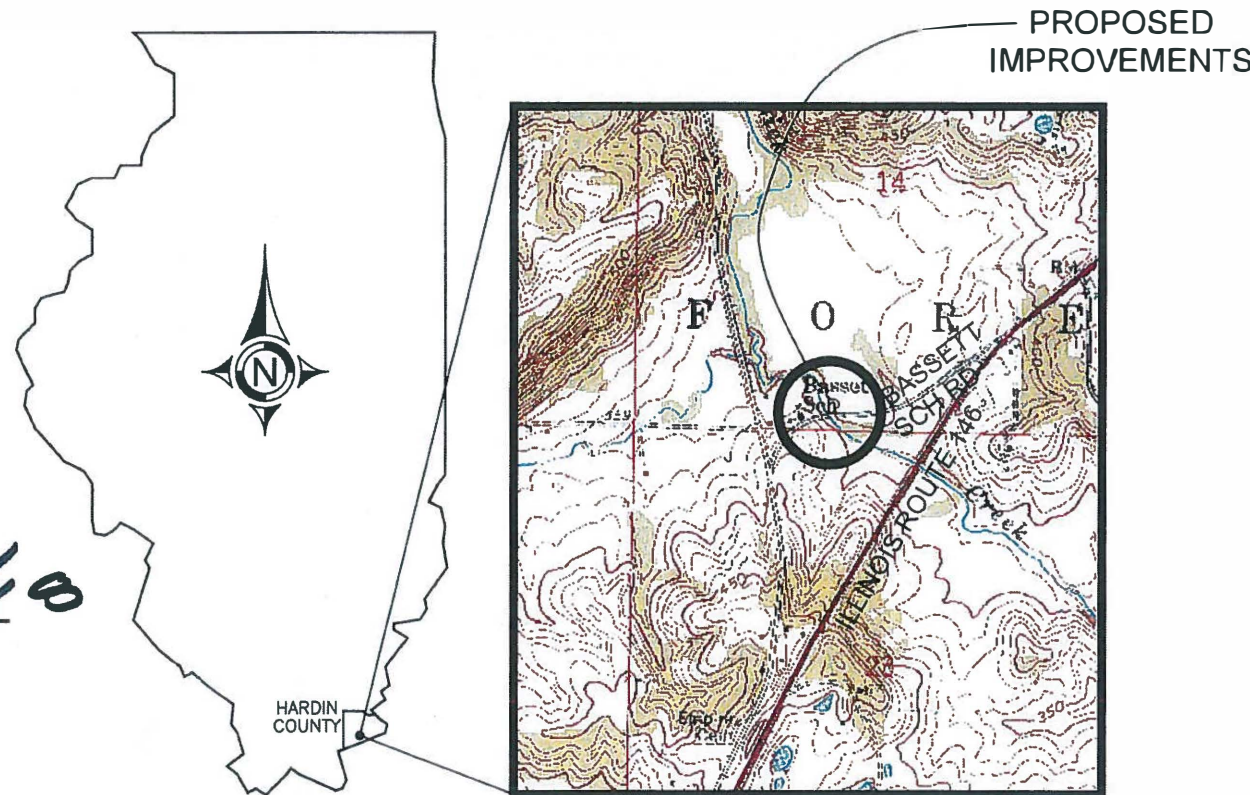

**LOCATION MAP**  
Scale 1 inch = 2,000 ft  
Length Of Improvements = 400 ft (0.076 mi)

STATE OF ILLINOIS DEPARTMENT OF TRANSPORTATION	
APPROVED	<i>Justin Flaherty</i> 3/16/18 HARDIN COUNTY ENGINEER
PASSED	<i>03-26-18</i> <i>[Signature]</i> DISTRICT 9 ENGINEER OF LOCAL ROADS & STREETS
RELEASING FOR BID BASED ON LIMITED REVIEW	<i>Jeffrey L. Keirn</i> 03-26-18 JEFFREY L. KEIRN, P.E. REGION FIVE ENGINEER

ROUTE	SECTION	COUNTY	TOTAL SHEETS	SHEET NO.
TR101C	12-01162-00-BR	HARDIN	11	2
BASSETT SCHOOL ROAD		CONTRACT 99583		

SUMMARY OF QUANTITIES			
ITEM NUMBER	ITEM DESCRIPTION	UNIT	TOTAL QUANTITY
* X2501000	SEEDING, CLASS 2 (SPECIAL)	ACRE	0.3
* Z0065000	SETTING PILES IN ROCK	EACH	5
* 20200100	EARTH EXCAVATION	CU YD	310
28000250	TEMPORARY EROSION CONTROL SEEDING	POUND	30
28000305	TEMPORARY DITCH CHECKS	FOOT	120
28000400	PERIMETER EROSION BARRIER	FOOT	150
* 28100807	STONE DUMPED RIPRAP, CLASS A4	TON	263
* 40200100	AGGREGATE SURFACE COURSE, TYPE A	TON	445
* 50100100	REMOVAL OF EXISTING STRUCTURES	EACH	1
50300225	CONCRETE STRUCTURES	CU YD	24.4
50300280	CONCRETE ENCASEMENT	CU YD	8.8
50400605	PRECAST PRESTRESSED CONCRETE DECK BEAMS (33" DEPTH)	SQ FT	1680
50800105	REINFORCEMENT BARS	POUND	2680
△ 50900205	STEEL RAILING, TYPE S1	FOOT	140
51201400	FURNISHING STEEL PILES HP 10X42	FOOT	185
51202305	DRIVING PILES	FOOT	95
51500100	NAME PLATES	EACH	1
△ 72501000	TERMINAL MARKER - DIRECT APPLIED	EACH	4
67100100	MOBILIZATION	L SUM	1

\* SEE SPECIAL PROVISIONS

△ SPECIALTY ITEMS

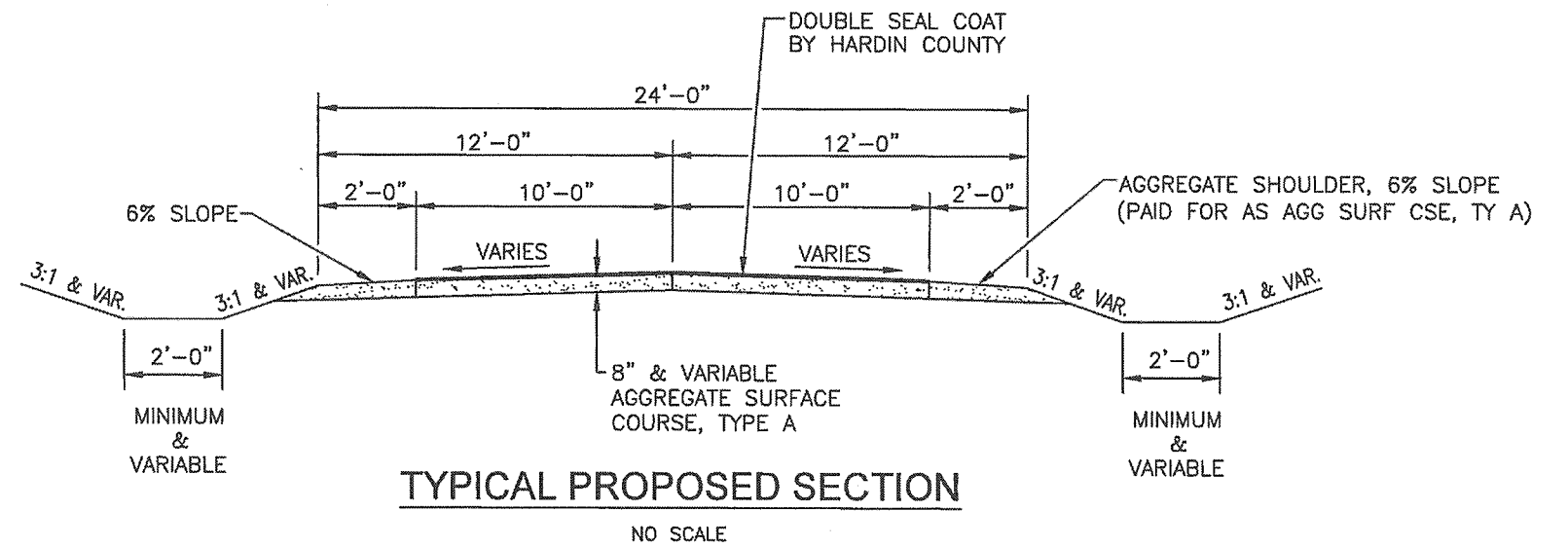

ROUTE	SECTION	COUNTY	TOTAL SHEETS	SHEET NO.
TR 101C	12-01162-00-BR	HARDIN	13	3
BASSETT SCHOOL ROAD		CONTRACT 99583		

**CURLED END SECTION DETAILS**

Note: Curled End Sections Shall Be Incidental To The Contract Price.

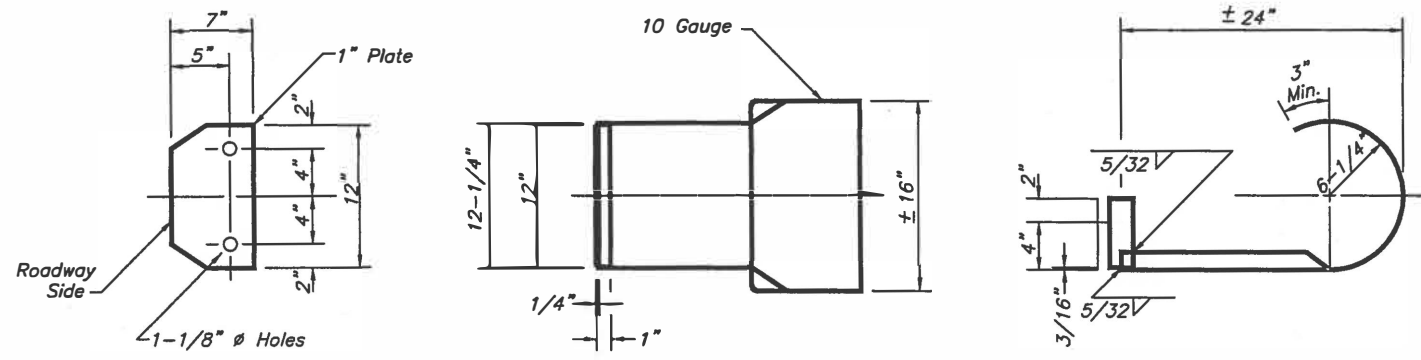

**GENERAL NOTES**

1. The Contractor shall drive 0 test piles, as specified, in a permanent location as directed by the Engineer before ordering the remaining piles.
2. See Special Provisions for boring logs.
3. A Corrosion inhibitor, as covered in the Special Provisions, shall be used in the concrete for precast prestressed concrete deck beams.
4. The Steel H-piles shall be according to AASHTO M270 Grade 50.

**DETAIL OF HP PILE ENCASEMENT**

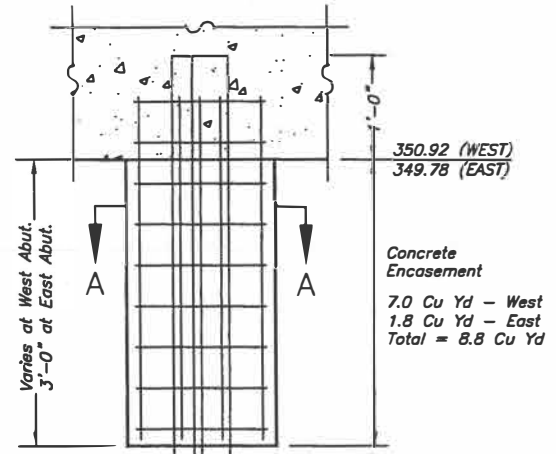

**TOTAL BILL OF MATERIAL**

Item	Unit	Super	Sub.		Total
			Piers	Abuts.	
Removal of Existing Structures	Each				1
Concrete Structures	Cu. Yd.			24.4	24.4
Precast Prestressed Concrete Deck Beams (33" Depth)	Sq. Ft.	1680			1680
Steel Railing, Type S-1	Foot	140			140
Reinforcement Bars	Pound			2680	2680
Furnishing Steel Piles HP 10X42	Foot			185	185
Driving Piles	Foot			95	95
Name Plates	Each				1
Concrete Encasement	Cu. Yd.			8.8	8.8
Setting Piles in Rock	Each			5	5

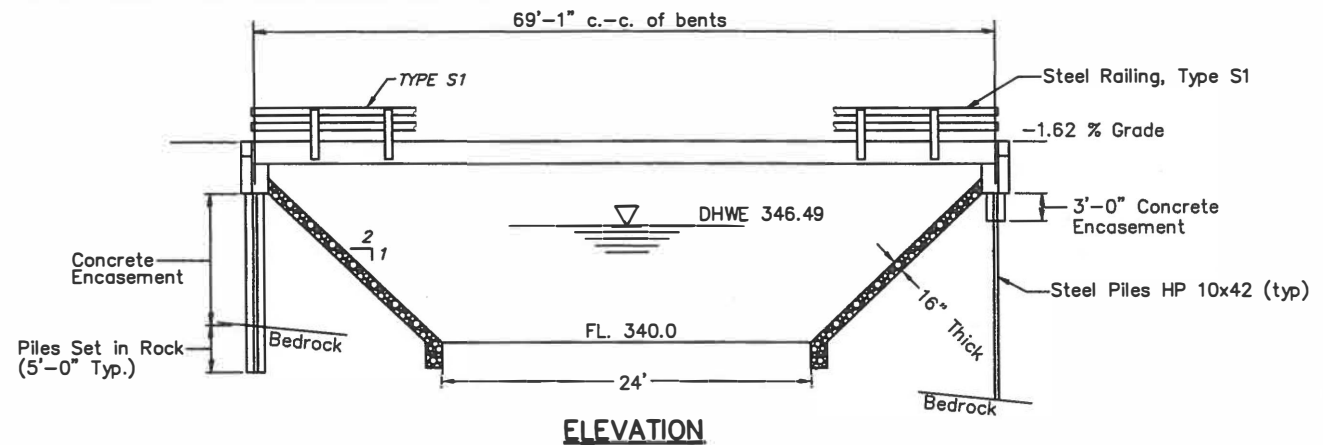

**ELEVATION**

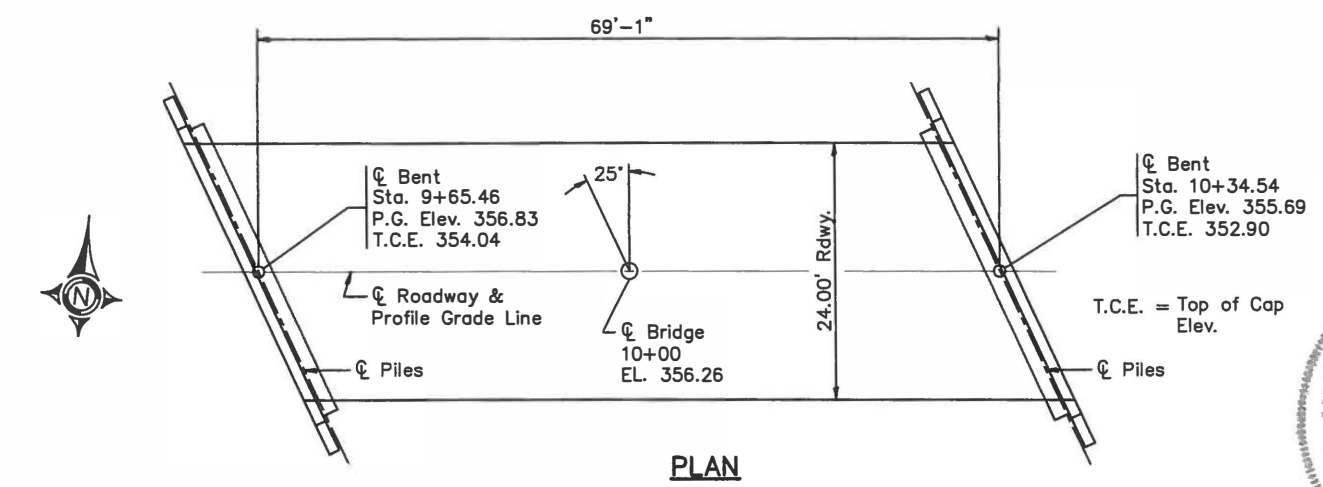

**PLAN**

STATION 10+00  
HOSICK CREEK  
SEC. 12-01162-00-BR BUILT 2017  
HARDIN COUNTY  
LOADING HL93  
STR. NO. 035-3057

**LETTERING FOR NAME PLATE**  
Locate Name Plate at SOUTHWEST Corner of Bridge

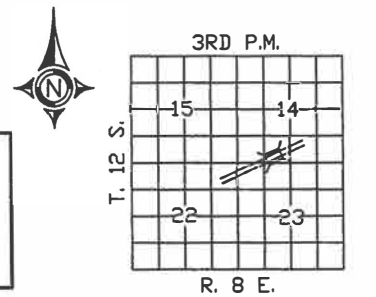

**LOCATION SKETCH**

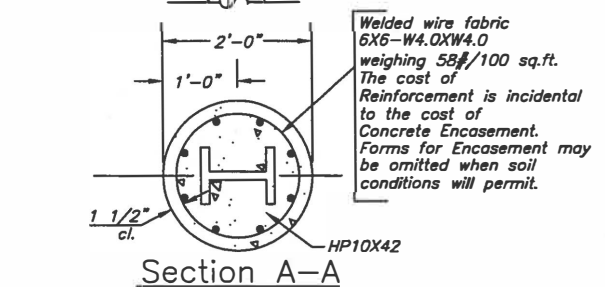

**Section A-A**

**QUANTITIES/LIN. FT. OF ENCASEMENT (STEEL PILES)**

PILE SIZE	ITEM	QUANTITY
HP 10	CONCRETE ENCASEMENT	0.116 C.Y.

**DESIGN SPECIFICATIONS**

2014 LRFD Specification - 7th ed.

**SEISMIC DATA**

Seismic Performance Zone (SPZ) = 2  
Design Spectral Acceleration at 1.0 sec. ( $S_{D1}$ ) = 0.255  
Design Spectral Acceleration at 0.2 sec ( $S_{D5}$ ) = 0.704  
Site Soil Class = C

**PILE DATA (2-ABUTS.)**

Type	STEEL HP 10X42
Estimated Length	18 Feet (West Abut.) 19 Feet (East Abut.)
Number Required	5 (West Abut.) 5 (East Abut.)
Nominal Required Bearing	335 KIPS
Allowable Resistance Available	184 KIPS

**LOADING HL-93**

ALLOW 50#/SQ.FT. FOR FUTURE WEARING SURFACE

**WATERWAY INFORMATION**

Drainage Area = 2.51 S.M. Low Grade Elev. = 352.45 @ Sta. 10+35									
Flood	Freq. Yr.	Q C.F.S.	Opening Exist.	Sq. Ft. Prop.	Nat. H.W.E.	Head - Ft. Exist.	Prop.	Headwater El. Exist.	Prop.
Design	25	1980	216	238	346.5	0.56	0.56	347.06	347.06
Base	100	2750	253	291	347.6	1.79	1.61	349.39	349.21
Overtopping									
Max. Calc.	500	3740	286	341	348.5	3.54	3.01	352.04	351.51

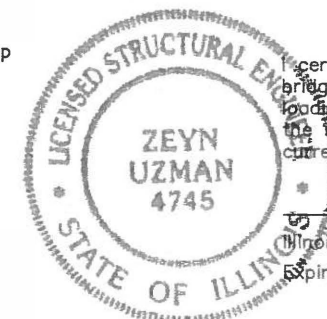

I certify that to the best of knowledge, information and belief, this bridge/box culvert design is structurally adequate for the design loading shown on the plans. The design is an economical one for the style of structure and complies with requirements of the current AASHTO Standard Specifications for Highway Bridges.  
Expires 11/30/2018

**GENERAL PLAN & ELEVATION**

TR 101C OVER  
HOSICK CREEK  
SECTION 12-01162-00-BR  
HARDIN COUNTY  
STATION 10+00

ROUTE	SECTION	COUNTY	TOTAL SHEETS	SHEET NO.
TR 101C	12-01162-00-BR	HARDIN	13	4
BASSETT SCHOOL ROAD		CONTRACT 99583		

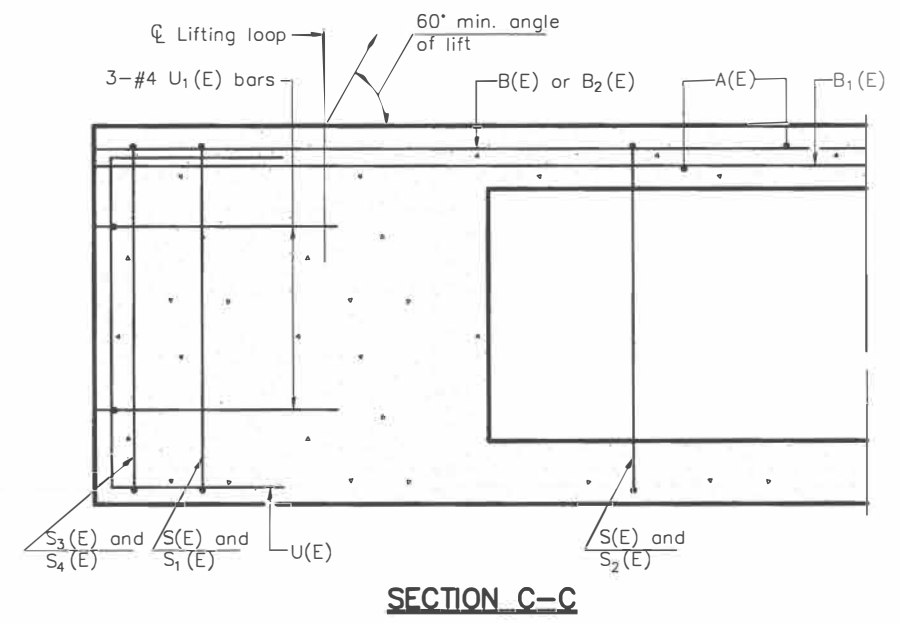

**SECTION C-C**

Omit key on exterior face of outside beams

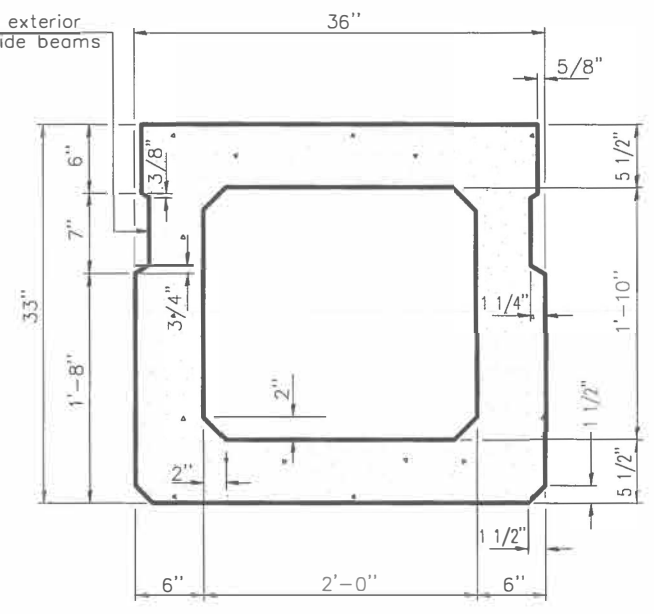

**SECTION A-A**  
(Showing dimensions)

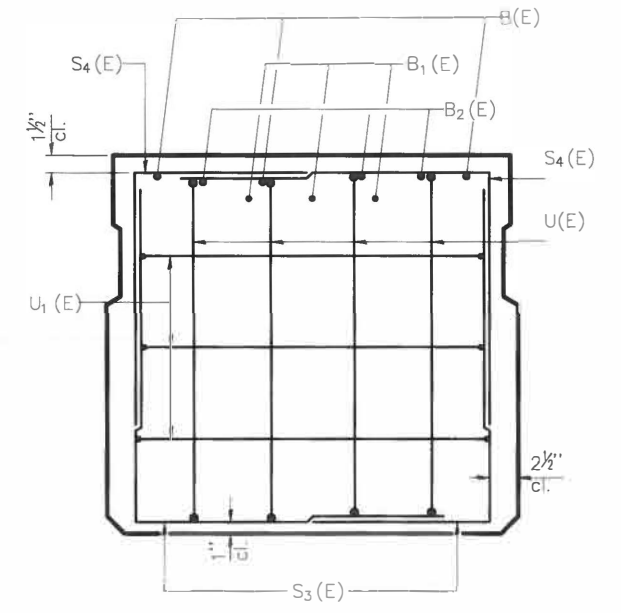

**VIEW B-B**

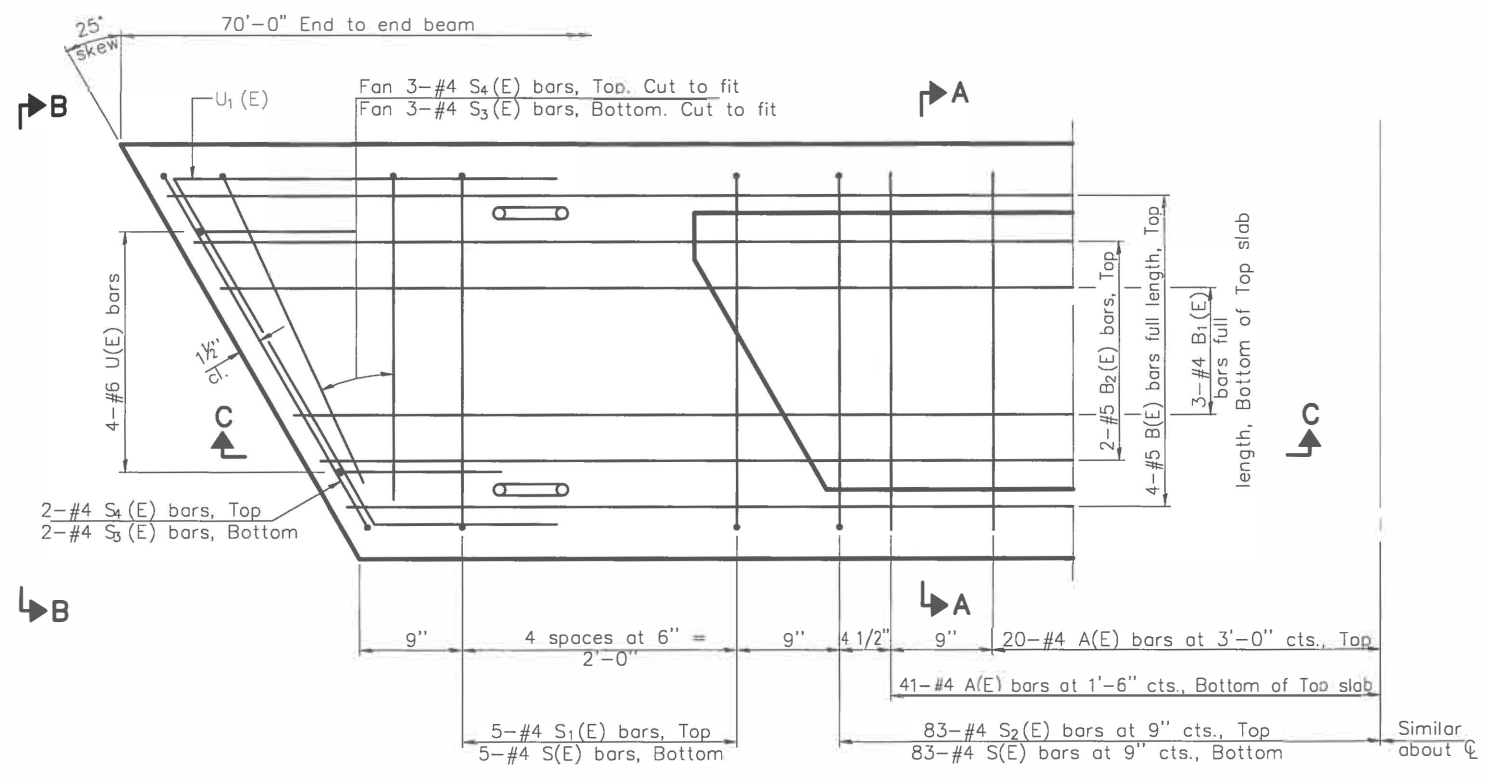

**PLAN VIEW**

Note: Spacing of S(E) and S<sub>2</sub>(E) bars may be adjusted up to 4" in the immediate area of the transverse tie diaphragms to miss the block outs for the transverse ties.

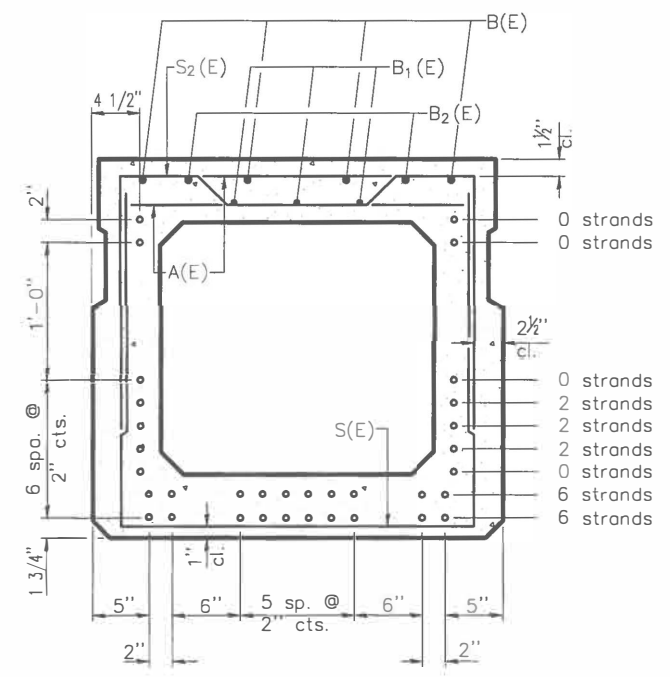

**SECTION A-A**

(Showing reinforcement and permissible strand locations)  
Note: Place the number of strands specified in each row symmetrically about the centerline of beam in the permissible strand locations shown.

**BAR LIST**  
**ONE BEAM ONLY**  
(For information only)

Bar	No.	Size	Length	Shape
A(E)	61	#4	2'-7"	—
B(E)	12	#5	25'-0"	—
B <sub>1</sub> (E)	9	#4	24'-8"	—
B <sub>2</sub> (E)	4	#5	10'-0"	—
S(E)	93	#4	7'-8"	U
S <sub>1</sub> (E)	10	#4	6'-5"	U
S <sub>2</sub> (E)	83	#4	6'-8"	U
S <sub>3</sub> (E)	6	#4	4'-6" cut	J
S <sub>4</sub> (E)	6	#4	4'-6" cut	J
U(E)	8	#6	5'-0"	U
U <sub>1</sub> (E)	6	#4	6'-4"	U

Note: See sheet 3 of 11 for additional details and Bill of Material.

**33" x 36" PPC DECK BEAM**  
**STRUCTURE NO. 035-3057**  
**SECTION 12-01162-00-BR**  
**BASSETT SCHOOL ROAD**

ROUTE	SECTION	COUNTY	TOTAL SHEETS	SHEET NO.
TR 101C	12-01162-00-BR	HARDIN	13	5
BASSETT SCHOOL ROAD			CONTRACT 99583	

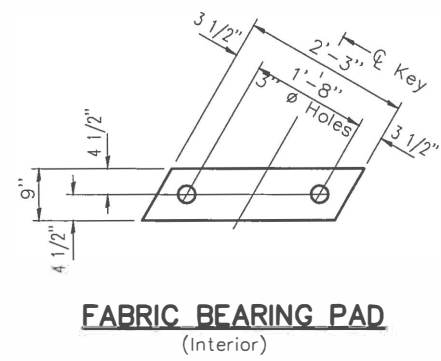

**FABRIC BEARING PAD**  
(Interior)

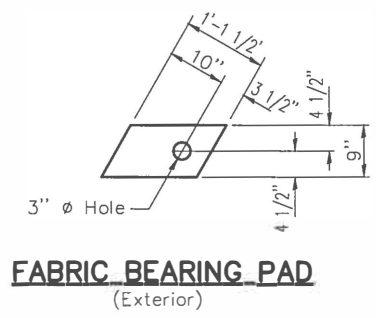

**FABRIC BEARING PAD**  
(Exterior)

**FIXED**

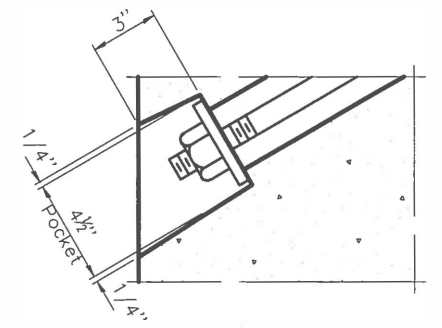

**SECTION A-A**

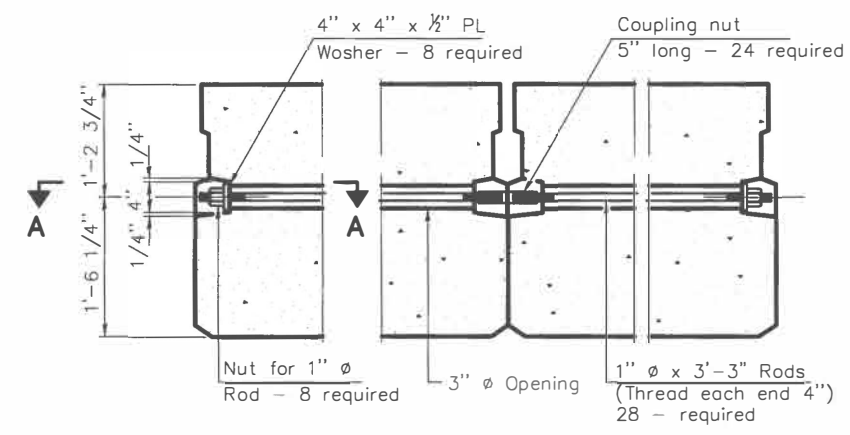

**TYPICAL TRANSVERSE TIE ASSEMBLY**

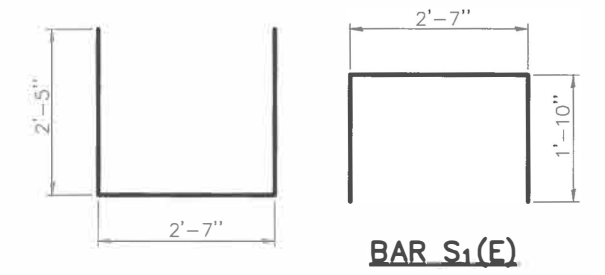

**BAR S1(E)**

**BAR S(E)**

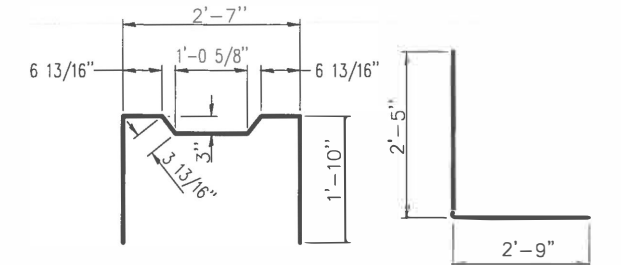

**BAR S2(E)**

**BAR S3(E)**

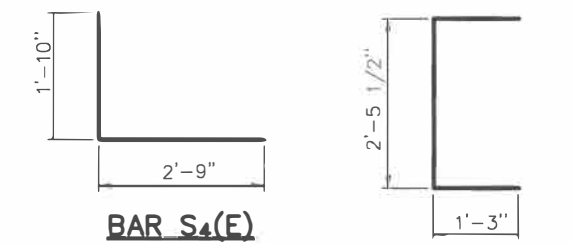

**BAR S4(E)**

**BAR U(E)**

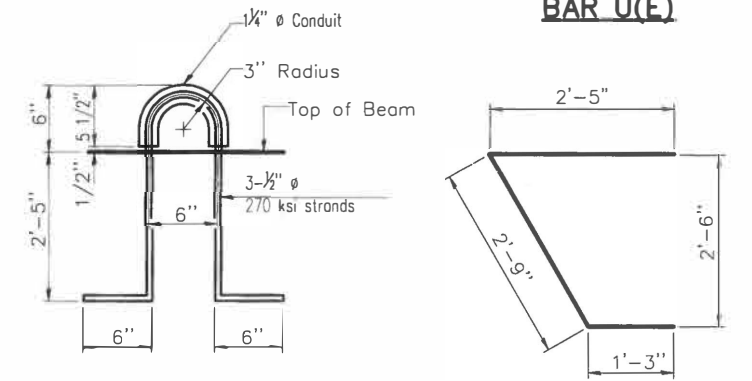

**LIFTING LOOP DETAIL**

**BAR U1(E)**

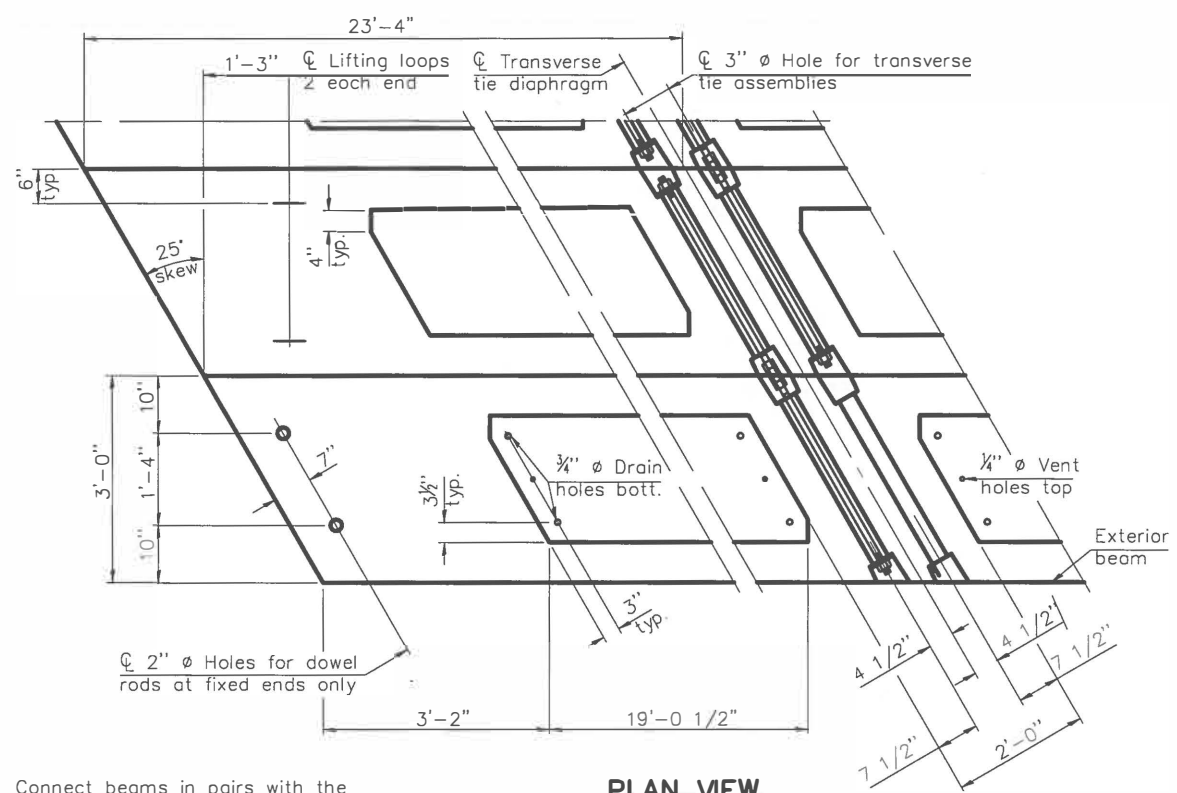

**PLAN VIEW**

Note: Connect beams in pairs with the transverse tie configuration shown.

**NOTES**

1. Prestressing steel shall be uncoated high strength, low relaxation 7-wire strand, Grade 270. The nominal diameter shall be 7/8" and the nominal cross-sectional area shall be 0.153 sq. in.
2. The 1" rods in the transverse tie assembly shall be tightened to a snug fit and the threads set. Pockets on exterior faces of bridge shall be filled with grout after transverse tie assembly is in place.
3. Reinforcement bars shall conform to ASTM A 706, Grade 60. (See Special Provisions).
4. Two 1/8" fabric adjusting shims of the dimensions of the exterior bearing pod shall be provided for each bearing pod location.
5. A minimum 2 1/2" diameter lifting pin shall be used to engage the lifting loops during handling.
6. Corrosion Inhibitor, per Article 1020.05(b)(12) and 1021.06 of the Standard Specifications, shall be used in the concrete for precast prestressed concrete deck beams.
7. Compressive strength of prestressed concrete, f'c, shall be 6000 psi.
8. Compressive strength of prestressed concrete at release, f'ci, shall be 5000 psi.

**BILL OF MATERIAL**

Precast Prestressed Conc. Deck Bms. (33" depth)	Sq. Ft. 1680
---	--------------

**33" X 36" PPC DECK BEAM DETAILS**  
STRUCTURE NO. 035-3057  
SECTION 12-01162-00-BR  
BASSETT SCHOOL ROAD



ROUTE	SECTION	COUNTY	TOTAL SHEETS	SHEET NO.
TR 101C	12-01162-00-BR	HARDIN	13	7
BASSETT SCHOOL ROAD		CONTRACT 99583		

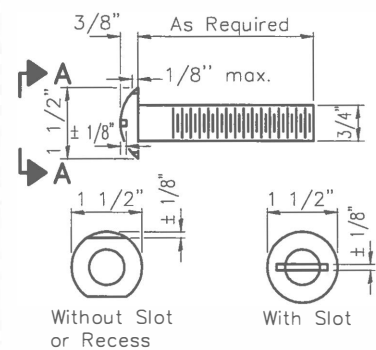

**VIEW A-A  
ROUND HEAD BOLT**

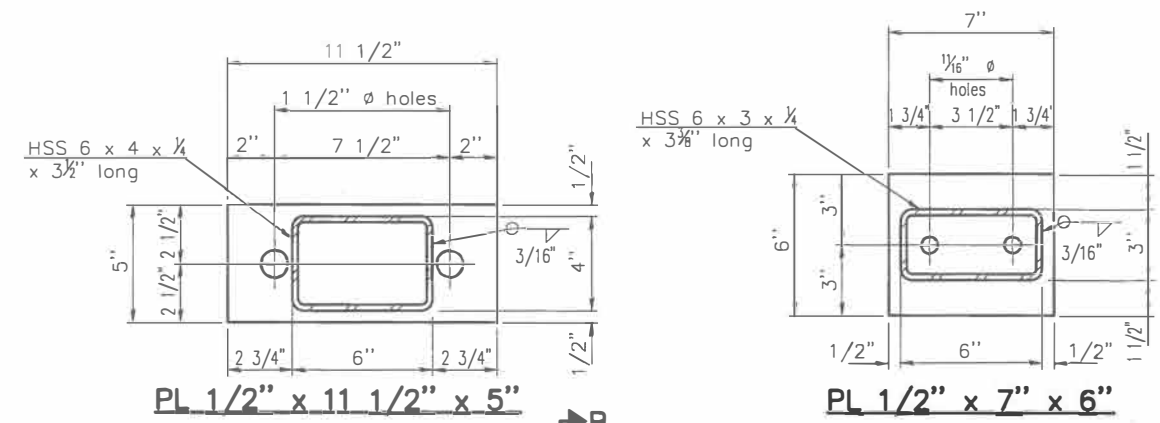

**PL 1/2" x 11 1/2" x 5"**

**PL 1/2" x 7" x 6"**

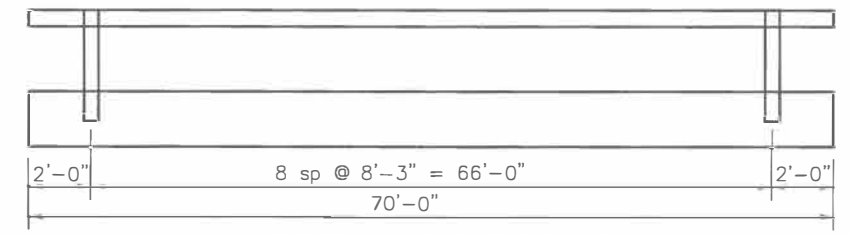

**ELEVATION OF RAILING**

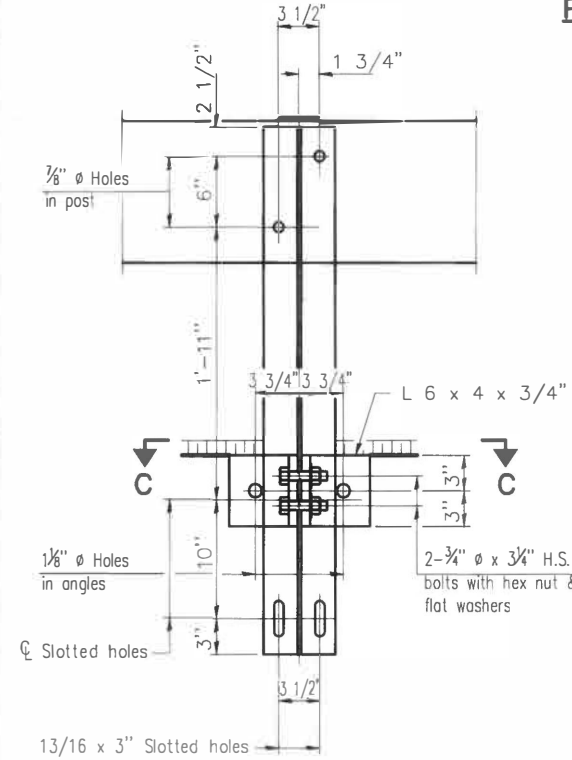

**SECTION B-B**

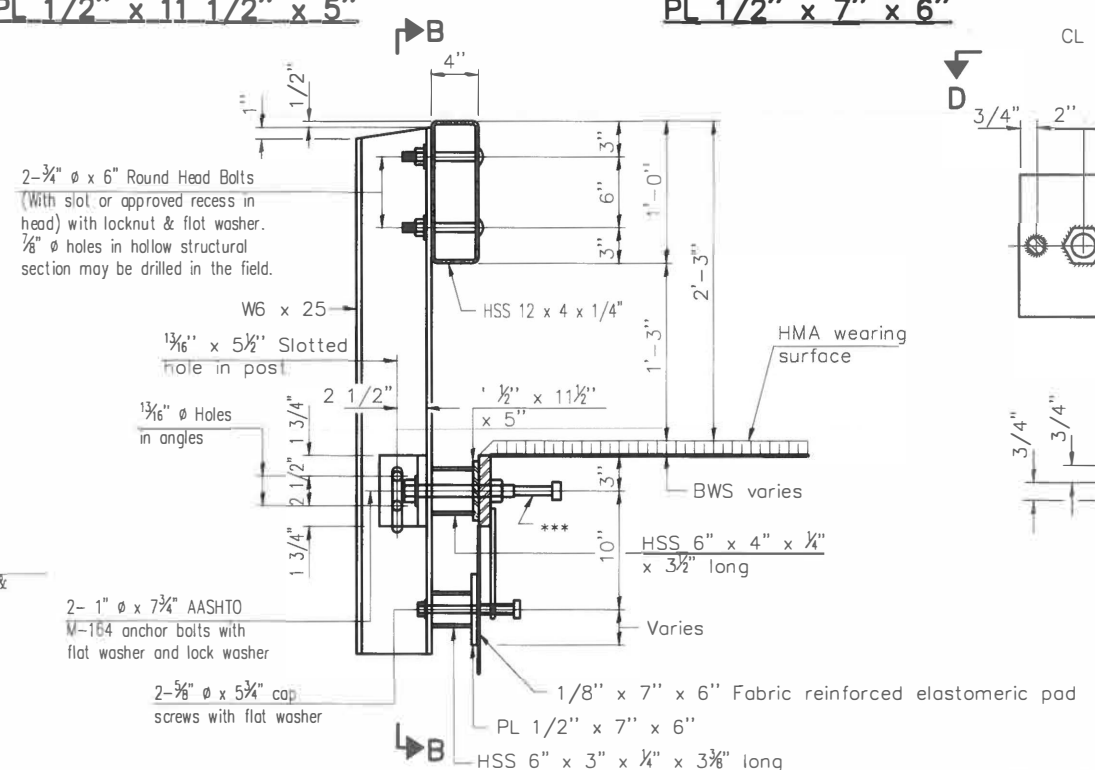

**SECTION AT RAILING POST**

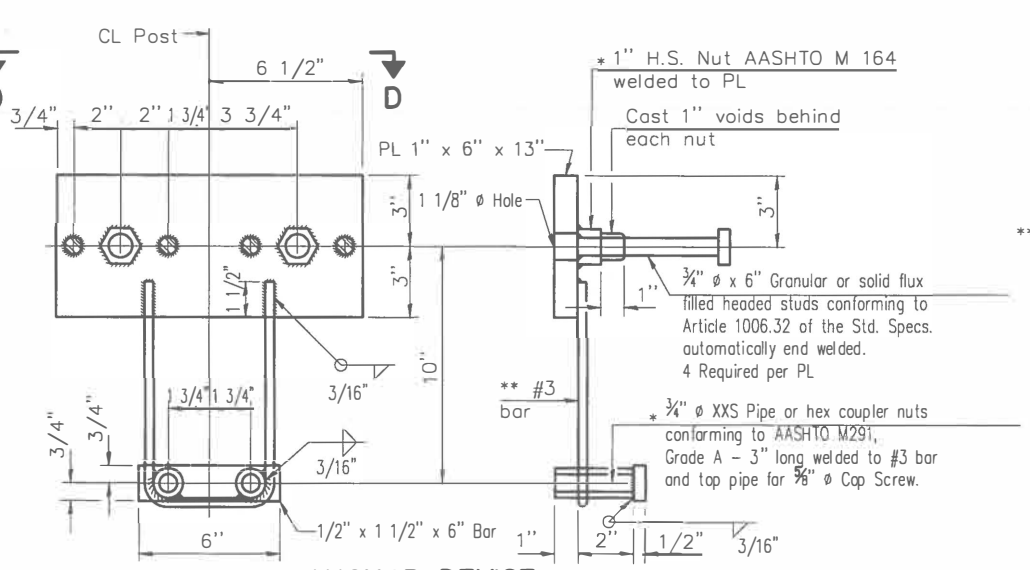

**ANCHOR DEVICE**

Notes:  
 All field drilled holes shall be coated with an approved zinc rich paint before erection.  
 For multi-span bridges, sufficient 1/2" x 6" x 1'-2" galvanized steel shims shall be provided to align rail between adjacent spans. Cost included with Steel Railing, Type S-1.  
 All steel rail elements shall be galvanized according to Article 509.05 of the Standard Specifications.  
 \*\*\* The studs of the anchor devices shall be placed below the top reinforcement bars and the outermost longitudinal reinforcement bar shall be placed directly above the studs of the rail post anchor device.

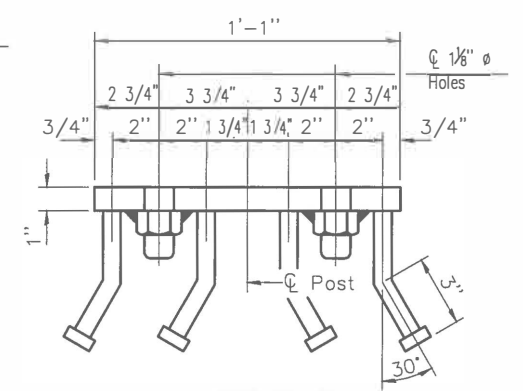

**VIEW D-D**

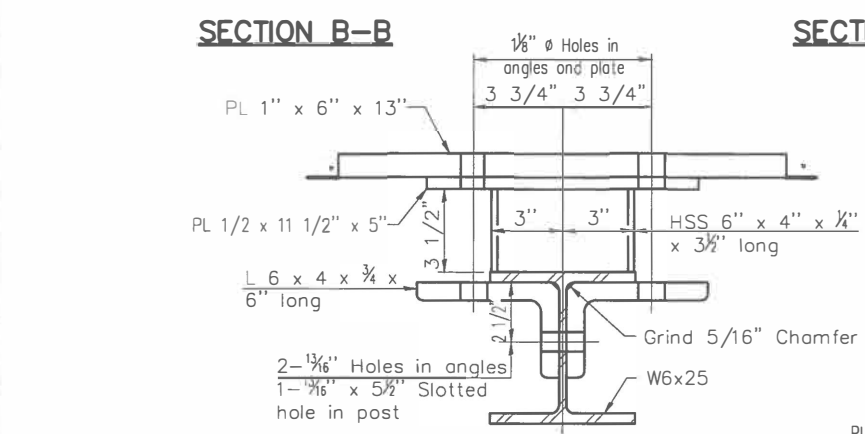

**SECTION C-C**

\*\* Whenever the lower insert assemblies interfere with strand locations, the #3 bars shall be cut and adjusted in order to allow raising or lowering of the lower inserts. Maximum adjustment not to exceed 1/2".

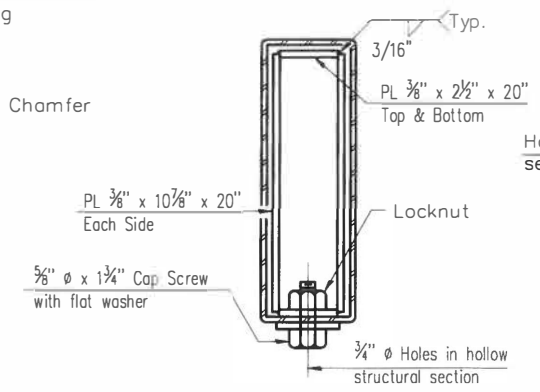

**SECTIONS AT RAIL SPLICE**

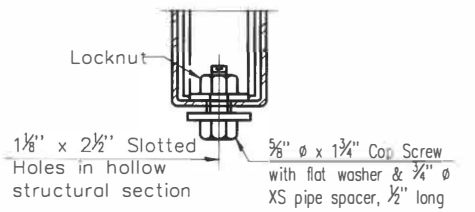

**RAIL SPLICE CONNECTION AT EXPANSION JT.**

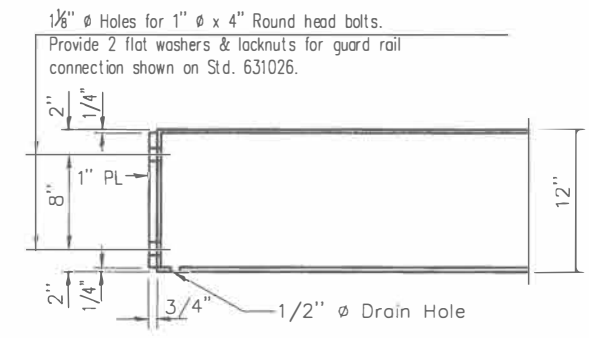

**END OF RAIL DETAILS**

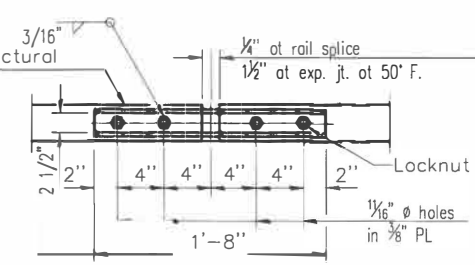

**PLAN-BOTT. SPLICE TYPICAL**

**BILL OF MATERIAL**

Item	Unit	Quantity
Steel Railing, Type S-1	Foot	140

**STEEL RAILING, TYPE S-1  
STRUCTURE NO. 035-3057**

**SECTION 12-01162-00-BR  
BASSETT SCHOOL ROAD**

09 Feb 2017 - 9:27am X:\2016\16087\AC\16087 S-1 Railing R-23A.dwg: Layout Tab Model

ROUTE	SECTION	COUNTY	TOTAL SHEETS	SHEET NO.
TR 101C	12-01162-00-BR	HARDIN	13	8
BASSETT SCHOOL ROAD		CONTRACT 99583		

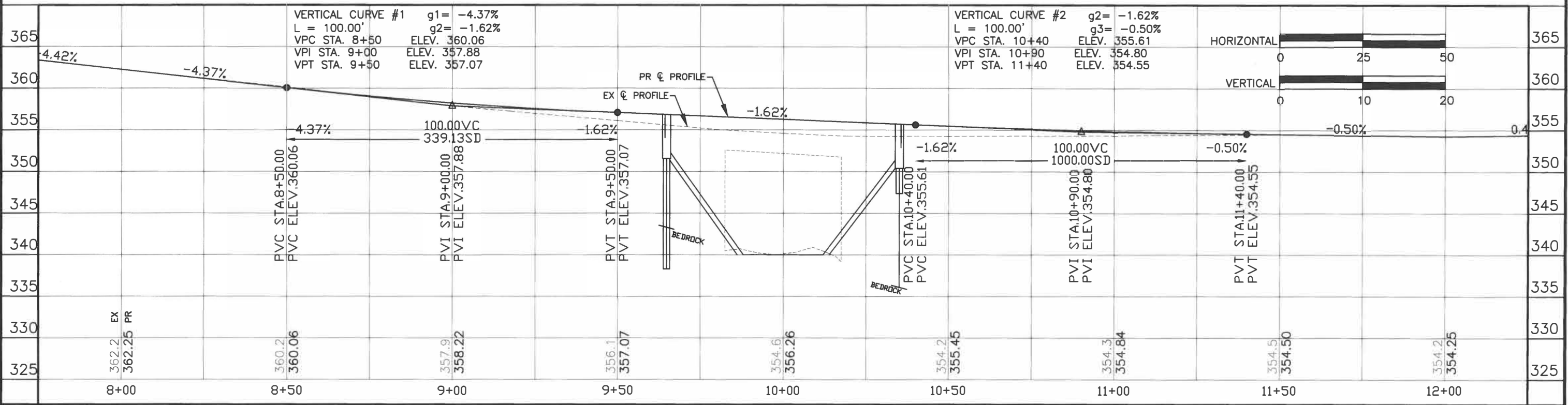
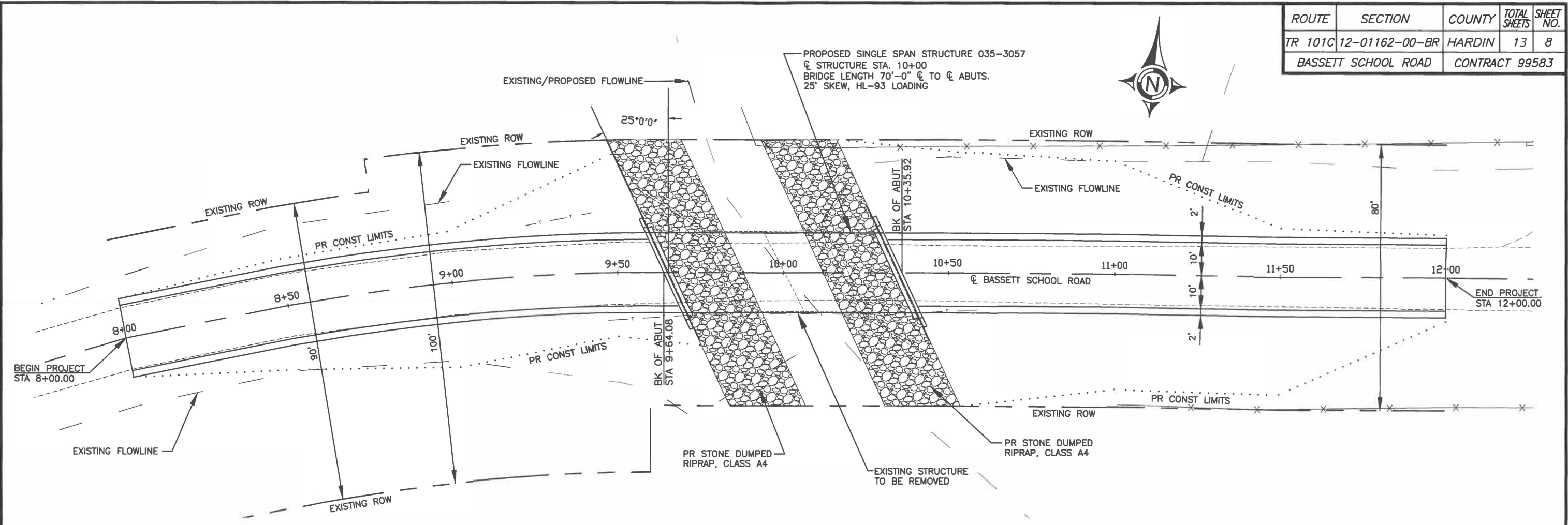

18 Mar 2017 1:33pm X:\2018\16087\AC\16087 Base.dwg: Layout Tab "PLAN-PROF"



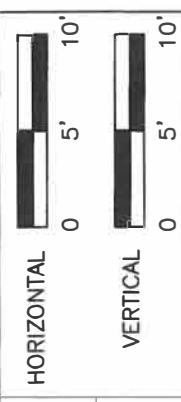

ROUTE	SECTION	COUNTY	TOTAL SHEETS	SHEET NO.
TR101C	12-01162-00-BR	HARDIN	13	9
BASSETT SCHOOL ROAD		CONTRACT 99583		

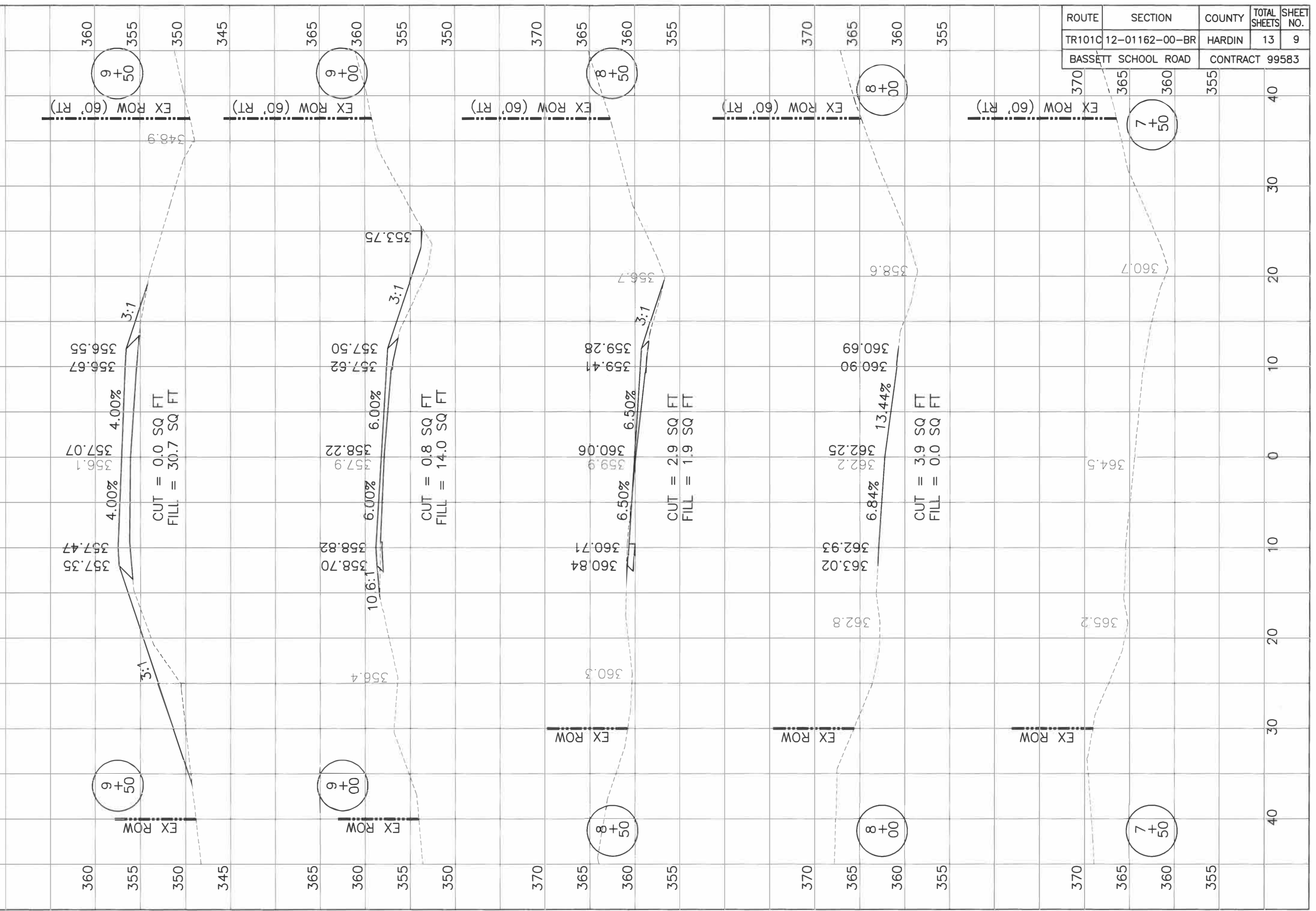

STATION	ELEVATION	EX ROW (60' RT)
9+50	355	355
00+00	360	360
8+50	360	360
8+00	360	360
7+50	360	360

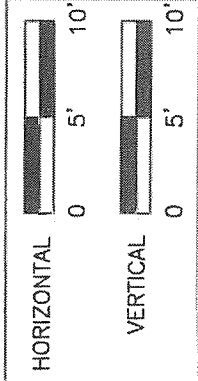

ROUTE	SECTION	COUNTY	TOTAL SHEETS	SHEET NO.
TR101C	12-01162-00-BR	HARDIN	13	10

BASSETT SCHOOL ROAD CONTRACT 99583

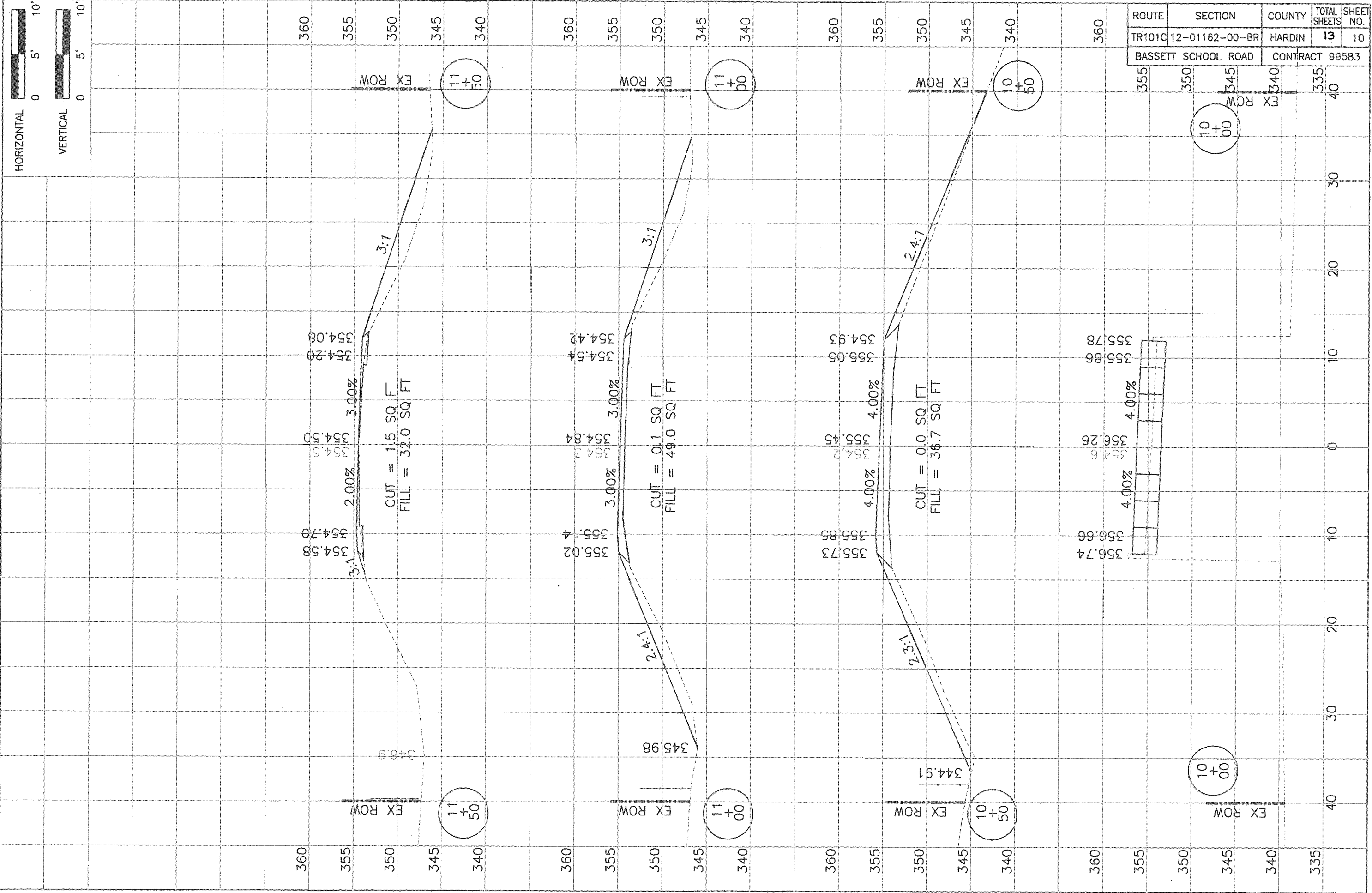

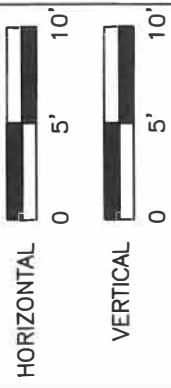

ROUTE	SECTION	COUNTY	TOTAL SHEETS	SHEET NO.
TR101C	12-01162-00-BR	HARDIN	13	11
BASSETT SCHOOL ROAD		CONTRACT 99583		

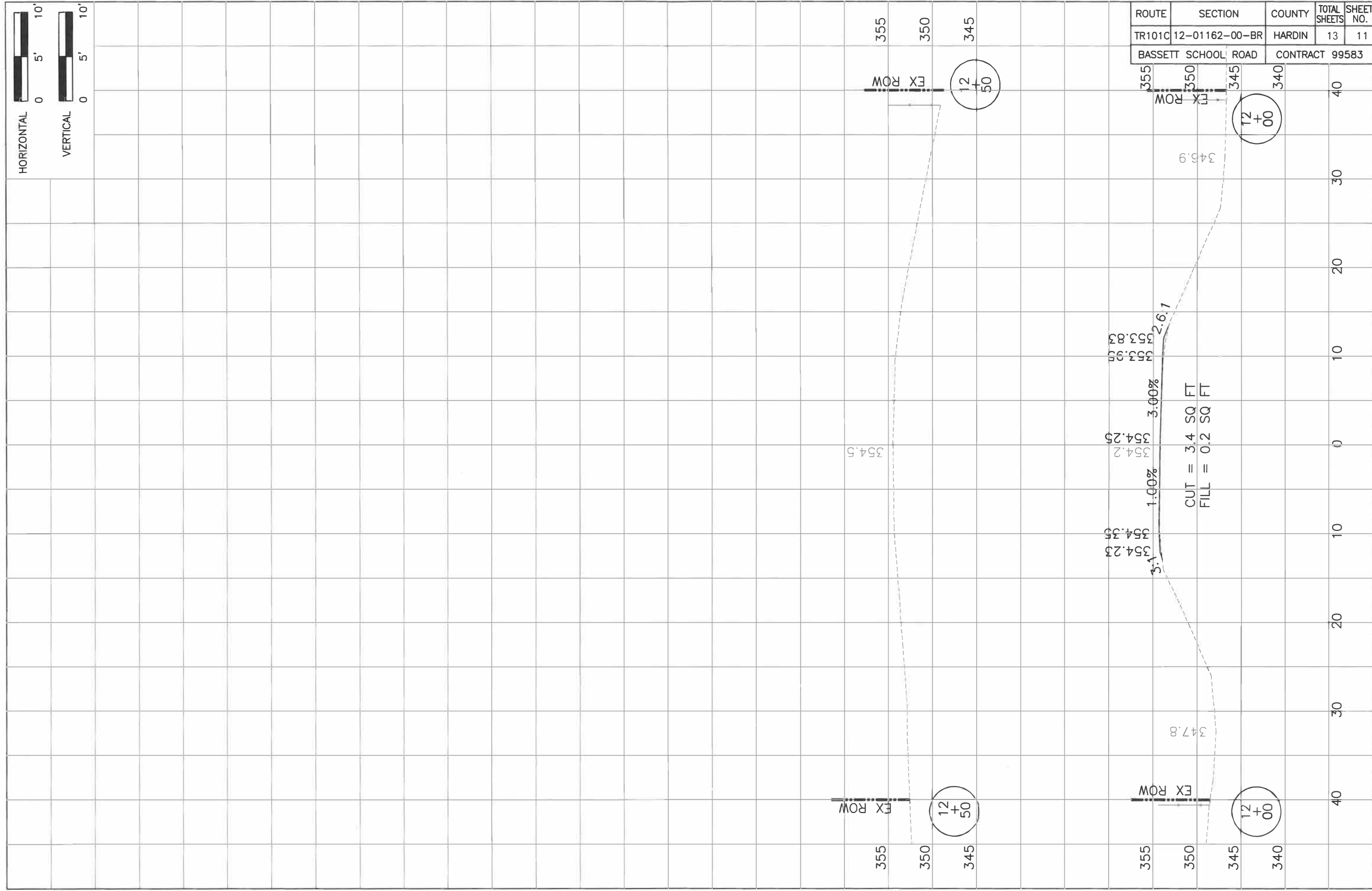

STORM WATER POLLUTION PREVENTION PLAN

ROUTE	SECTION	COUNTY	TOTAL SHEETS	SHEET NO.
TR 101C	12-01162-00-BR	HARDIN	13	12
BASSETT SCHOOL RD			CONTRACT 99583	

AREA OF CONSTRUCTION SITE

1. The total area of the construction site is estimated to be 0.78 Acres of which approximately 0.50 Acres will be disturbed.

OTHER REPORTS, STUDIES AND PLANS WHICH AID IN THE DEVELOPMENT OF THE SWPPP AS REFERENCED DOCUMENTS.

1. Information of the terrain was obtained from topographic maps.
2. Project plan documents, specifications and special provisions and plan drawings indicating the drainage patterns and location of existing drainage features were utilized in the preparation of the proposed placement of temporary erosion control systems.

DRAINAGE TRIBUTARIES AND SENSITIVE AREAS RECEIVING RUNOFF

1. No new discharge points will be constructed.

CONTROLS - EROSION CONTROLS AND SEDIMENT CONTROLS

1. Existing vegetation will be preserved where attainable and disturbed portions of the site will be stabilized. Stabilization practices will include temporary seeding, permanent seeding, mulching, protection of trees, preservation of mature vegetation and other appropriate measures as directed by the Engineer. Stabilization measures shall be initiated as soon as practical in those areas of the site where construction activities have ceased, but in no case more than 7 days after the construction activity for an area has temporarily or permanently ceased.
2. Areas outside the construction limits shall be protected from construction activities.
3. Dead, diseased or unsuitable vegetation within the site shall be removed as directed by the Engineer.
4. As soon as is reasonable, the temporary erosion control system shall be installed as indicated in the plans or as directed by the engineer.

This plan has been prepared with the intent to comply with the provisions of the NPDES Permit Number ILR10, issued by the Illinois Environmental Protection Agency for storm water discharges from construction site activities.

I certify under penalty of law that this plan was prepared at my direction in accordance with a system that qualified personnel properly gathered and evaluated the information submitted. Based on my inquiry of the person or persons who manage the system, or those persons directly responsible for gathering the information, the information submitted is, to the best of my knowledge and belief, true, accurate and complete. I am aware that there are significant penalties for submitting false information, including the possibility of fine and imprisonment.

3/16/18  
 JUSTIN HASTIE, COUNTY ENGINEER                      DATE:

The following Plan is established and incorporated in the project to direct the Contractor in the placement of temporary erosion control systems and to provide a storm water pollution prevention plan for compliance under NPDES.

The purpose of this plan is to minimize erosion within the construction site and to limit sediments leaving the construction site by utilizing proper temporary erosion control systems and providing ground cover within a reasonable amount of time.

Certain erosion control facilities shall be installed by the Contractor at the beginning of construction. Other items shall be installed as directed by the Engineer on a case by case situation depending on the Contractor's sequence of activities, time of year and expected weather conditions.

The Contractor shall construct permanent erosion control systems and seeding within a time frame specified herein and as directed by the Engineer, therefore minimizing the amount of area susceptible to erosion and reducing the amount of temporary seeding. The engineer will determine if any temporary erosion control systems shown in the plans can be deleted and if any additional temporary erosion control systems, which are not included in the plans, shall be added. The contractor shall perform all work as directed by the Engineer and as shown in STANDARD 280001.

Section 280, Temporary Erosion Control, of the Standard Specifications additionally supplements this plan.

DESCRIPTION OF CONSTRUCTION ACTIVITIES

1. Temporary ditch checks shall be located at every 1.5 feet of fall/rise in ditch grade.

INTENDED SEQUENCE OF MAJOR CONSTRUCTION ACTIVITIES

1. Brush removal. Trees to remain will be protected against damage.
2. Remove Existing Bridge.
3. Construct Abutments.
4. Place new Riprap.
5. Construct New Bridge Deck.
6. Construct roadway transitions and side slopes.
7. Seeding and permanent erosion control systems.

15 Mar 2018 - 10:40am X:\2016\16087\AC\16087 SWPPP.dwg

DESCRIPTION OF STABILIZATION PRACTICES  
DURING CONSTRUCTION

1. During construction, areas outside the construction limits shall be protected.
2. Within the construction limits, areas which may be susceptible to erosion as determined by the Engineer shall remain undisturbed until full scale construction is underway.
3. Earth stockpiles shall be temporary seeded if they are to remain unused for more than 14 days.
4. As soon as construction proceeds, the contractor shall institute the following as directed by the Engineer:
  - A) Place temporary erosion control facilities at locations shown in the plans.
  - B) Temporarily seed erodable bare earth on a weekly basis to minimize the amount of erodable surface area within the contract limits.
  - C) Construct roadside ditches and provide temporary erosion control systems.
  - D) Temporarily divert water around proposed culvert locations.
5. Excavated areas shall be permanently seeded immediately after final grading. If not, they shall be temporarily seeded if no construction in the area is planned for 7 days.
6. All necessary measures shall be taken by the contractor to contain any fuel or pollutant in accordance with EPA water quality regulations. Leaking equipment or supplies shall be immediately repaired or removed from the site.
7. The Resident Engineer shall inspect the project daily during construction activities. Inspection shall also be done weekly and after rains of 0.5 inches or greater or equivalent snowfall and during any winter shutdown period.
8. Sediment collected during the construction by the various temporary erosion control systems shall be disposed of on site on a regular basis as directed by the Resident Engineer. The cost of this maintenance shall be considered incidental to the erosion control system.
9. The temporary erosion control systems shall be removed as directed by the Engineer after use is no longer needed or no longer functioning. The cost of removal shall be included in the unit bid price for various temporary erosion control pay items.

DESCRIPTION OF STRUCTURAL PRACTICES  
AFTER FINAL GRADING

1. Temporary seeding shall be left in place with proper maintenance until permanent erosion control and all proposed turf areas seeded and established.
2. Once permanent erosion control systems as proposed in the plans are functional and established, temporary items shall be removed, cleaned up and disturbed turf areas reseeded.

MAINTENANCE AFTER CONSTRUCTION

1. Construction is complete after FINAL acceptance by I.D.O.T. final inspection. Maintenance up to this date will be by the contractor.

MISCELLANEOUS

1. Temporary ditch checks shall be located at every 1.5 feet of fall/rise in ditch grade.
2. Temporary erosion control seeding shall be applied at the rate of 100 lbs/acre.
3. Straw bales, hay bales, perimeter erosion control barrier and silt fences will not be permitted for temporary or permanent ditch checks. Ditch checks shall be composed of aggregate, silt panels, rolled excelsior, urethane foam geotextile (silt wedges) and/or other material approved by the erosion and sediment control coordinator.
4. All erosion control products furnished shall be specifically recommended by the manufacturer for the use specified in the erosion control plan. Prior to the approval and use of the product, the contractor shall submit to the Engineer a notarized certification by the producer stating the intended use of the product and the physical properties required for this application are met or exceeded. The contractor shall provide manufacturer installation procedures to facilitate the Engineer in construction inspection.
5. All items shall be constructed as shown on STANDARD 280001 and as directed by the Engineer. Maintenance and cleaning of erosion control items shall be considered part of the respective erosion control pay item.

ROUTE	SECTION	COUNTY	TOTAL SHEETS	SHEET NO.
TR 101C	12-01162-00-BR	HARDIN	13	13
BASSETT SCHOOL ROAD		CONTRACT 99583		