

Notes:
 All field drilled holes shall be coated with an approved zinc rich paint before erection.
 For multi-span bridges, sufficient 1/4" x 6" x 1'-2" galvanized steel shims shall be provided to align rail between adjacent spans. Cost included with Steel Railing, Type S-1.
 All steel rail elements shall be galvanized according to Article 509.05 of the Standard Specifications.
 *** The studs of the anchor devices shall be placed below the top reinforcement bars and the outermost longitudinal reinforcement bar shall be placed directly above the studs of the rail post anchor device.

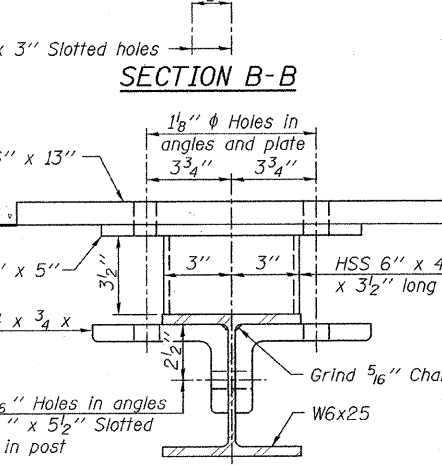

** Whenever the lower insert assemblies interfere with strand locations, the #3 bars shall be cut and adjusted in order to allow raising or lowering of the lower inserts. Maximum adjustment not to exceed 1/2".

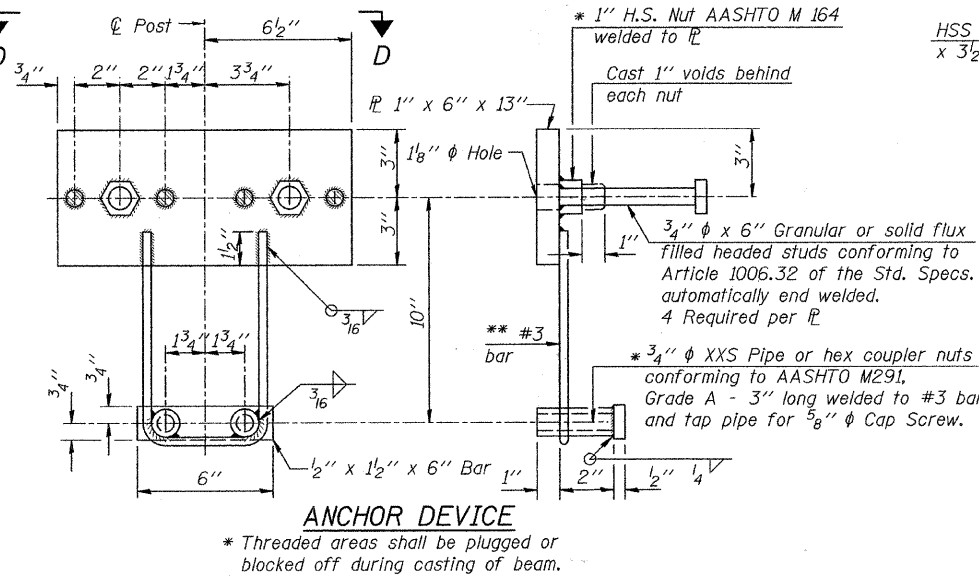
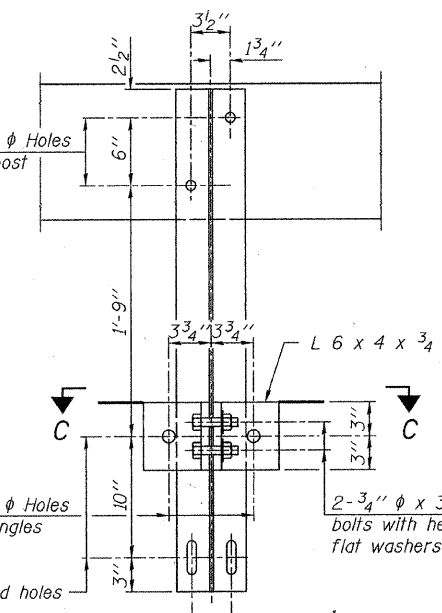
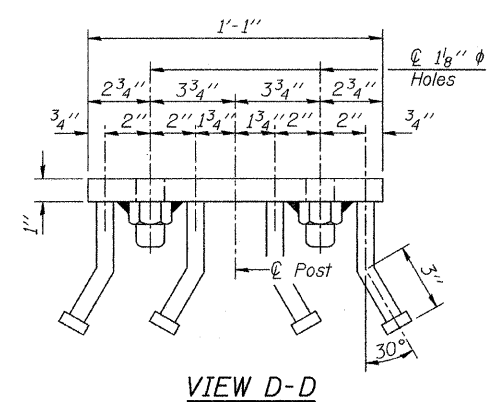
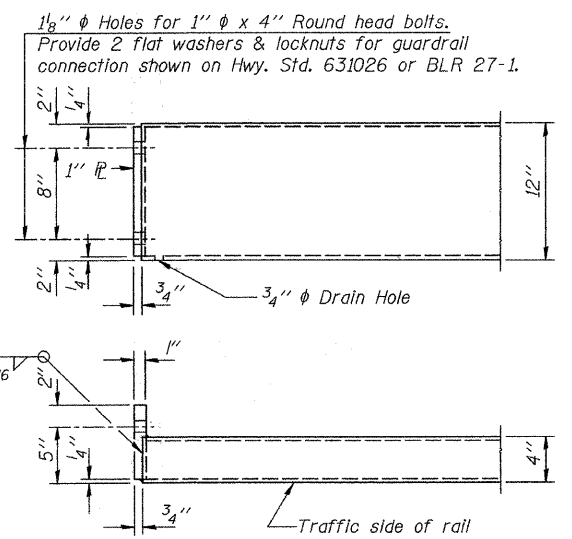
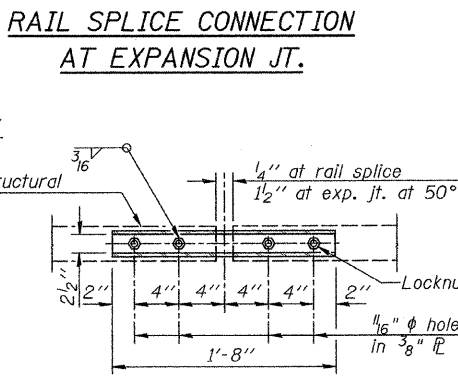
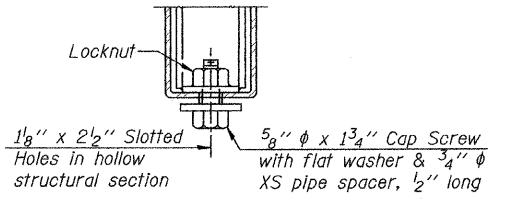

R-23A
 7-1-10 (10'-9" Maximum Post Spacing)

SECTIONS AT RAIL SPLICE

PLAN-BOTT. SPLICE R TYPICAL

END OF RAIL DETAILS

BILL OF MATERIAL

Item	Unit	Quantity
Steel Railing, Type S-1	Foot	352