

RETURN WITH BID

State of _____)
) ss.
County of _____)

AFFIDAVIT

_____ (name of affiant), of _____,

_____, being first duly sworn upon oath, states as follows:

1. That I am the _____ (officer or position) of _____ (bidder) and have personal knowledge of the facts herein stated.
2. That, if selected under this proposal, _____ (bidder) will maintain a business office in the State of Illinois which will be located in _____ County, Illinois.
3. That this business office will serve as the primary place of employment for any persons employed in the construction contemplated by this proposal.
4. That this Affidavit is given as a requirement of state law as provided in Section 30-22(8) of the Illinois Procurement Code.

Signature

Print Name of Affiant

This instrument was acknowledged before me on the _____ day of _____, 20__ by _____.

Notary Public

(SEAL)

INSTRUCTIONS

ABOUT IDOT PROPOSALS: All proposals are potential bidding proposals. Each proposal contains all certifications and affidavits, a proposal signature sheet and a proposal bid bond.

PREQUALIFICATION

Any contractor who desires to become pre-qualified to bid on work advertised by IDOT must submit the properly completed pre-qualification forms to the Bureau of Construction no later than 4:30 p.m. prevailing time twenty-one days prior to the letting of interest. This pre-qualification requirement applies to first time contractors, contractors renewing expired ratings, contractors maintaining continuous pre-qualification or contractors requesting revised ratings. To be eligible to bid, existing pre-qualification ratings must be effective through the date of letting.

WHO CAN BID ?

Bids will be accepted from only those companies that request and receive written Authorization to Bid from IDOT's Central Bureau of Construction. This does not apply to Small Business Set-Asides.

REQUESTS FOR AUTHORIZATION TO BID

Contractors wanting to bid on items included in a particular letting must submit the properly completed "Request for Authorization to Bid/or Not For Bid Status" (BDE 124) and the ORIGINAL "Affidavit of Availability" (BC 57) to the proper office no later than 4:30 p.m. prevailing time, three (3) days prior to the letting date. This does not apply to Small Business Set-Asides.

WHAT CONSTITUTES WRITTEN AUTHORIZATION TO BID?: When a prospective prime bidder submits a "Request for Authorization to Bid/or Not For Bid Status"(BDE 124) he/she must indicate at that time which items are being requested For Bidding purposes. Only those items requested For Bidding will be analyzed. After the request has been analyzed, the bidder will be issued an **Authorization to Bid or Not for Bid Report**, approved by the Central Bureau of Construction that indicates which items have been approved For Bidding. If **Authorization to Bid** cannot be approved, the **Authorization to Bid or Not for Bid Report** will indicate the reason for denial.

ABOUT AUTHORIZATION TO BID: Firms that have not received an Authorization to Bid or Not For Bid Report within a reasonable time of complete and correct original document submittal should contact the department as to the status. Firms unsure as to authorization status should call the Prequalification Section of the Bureau of Construction at the number listed at the end of these instructions. These documents must be received three days before the letting date.

ADDENDA AND REVISIONS: It is the bidder's responsibility to determine which, if any, addenda or revisions pertain to any project they may be bidding. Failure to incorporate all relevant addenda or revisions may cause the bid to be declared unacceptable.

Each addendum or revision will be included with the Electronic Plans and Proposals. Addenda and revisions will also be placed on the Addendum/Revision Checklist and each subscription service subscriber will be notified by e-mail of each addendum and revision issued.

The Internet is the Department's primary way of doing business. The subscription server e-mails are an added courtesy the Department provides. It is suggested that bidders check IDOT's website at <http://www.dot.il.gov/desenv/delett.html> before submitting final bid information.

IDOT IS NOT RESPONSIBLE FOR ANY E-MAIL FAILURES.

Addenda questions may be directed to the Plans and Contracts Office at (217)782-7806 or D&Econtracts@dot.il.gov

Technical questions about downloading these files may be directed to Tim Garman at (217)524-1642 or Timothy.Garman@illinois.gov.

BID SUBMITTAL GUIDELINES AND CHECKLIST

In an effort to eliminate confusion and standardize the bid submission process the Contracts Office has created the following guidelines and checklist for submitting bids.

This information has been compiled from questions received from contractors and from inconsistencies noted on submitted bids. If you have additional questions please refer to the contact information listed below.

ABOUT SUBMITTING BIDS: It is recommended that bidders deliver bid proposals in person to ensure they arrive at the proper location prior to the time specified for the receipt of bids. Any proposals received at the place of letting after the time specified will not be read.

STANDARD GUIDELINES FOR SUBMITTING BIDS

- All pages should be single sided.
- Use the Cover Page that is provided in the Bid Proposal (posted on the IDOT Web Site) as the first page of your submitted bid. This page has the Item number in the upper left-hand corner and lines provided for your company name and address in the upper right-hand corner.
- Do not use report covers, presentation folders or special bindings and do not staple multiple times on left side like a book. Use only 1 staple in the upper left hand corner. Make sure all elements of your bid are stapled together including the bid bond or guaranty check (if required).
- Do not include any certificates of eligibility, your authorization to bid, Addendum Letters or affidavit of availability.
- Do not include the Subcontractor Documentation with your bid (pages i – iii and pages a – g). This documentation is required only after you are awarded the contract.
- Use the envelope cover sheet (provided with the proposal) as the cover for the proposal envelope.
- Do not rely on overnight services to deliver your proposal prior to 10 AM on letting day. It will not be read if it is delivered after 10 AM.
- Do not submit your Substance Abuse Prevention Program (SAPP) with your bid. If you are awarded the contract this form is to be submitted to the district engineer at the pre-construction conference.

Use the following checklist to ensure completeness and the correct order in assembling your bid

Cover page followed by the Pay Items. If you are using special software or CBID to generate your schedule of prices, do not include the blank schedule of prices.

Page 4 (Item 9) – Check “YES” if you will use a subcontractor(s). Include the subcontractor(s) name, address and the dollar amount (if over \$25,000). If you will use subcontractor(s) but are uncertain who or the dollar amount; check “YES” but leave the lines blank.

After page 4, Insert affidavit for having an office in Illinois, your Cost Adjustments for Steel, Bituminous and Fuel (if applicable), and your State Board of Elections certificate of registration.

Page 10 (Paragraph J) – Check “YES” or “NO” whether your company has any business in Iran.

Page 10 (Paragraph K) – List the Union Local Name and number or certified training programs that you have in place. Do not include certificates with your bid. Keep the certificates in your office in case they are requested by IDOT.

Page 11 (Paragraph L) - Insert a copy of your State Board of Elections certificate of registration after page 4 of the bid proposal. Only include the page that has the date stamp on it. Do not include any other certificates or forms showing that you are an Illinois business.

Page 11 (Paragraph M) – Indicate if your company has hired a lobbyist in connection with the job for which you are submitting the bid proposal.

Page 12 (Paragraph C) – This is a work sheet to determine if a completed Form A is required. It is not part of the form and you do not need to make copies for each Form A that is filled out.

Pages 14-17 (Form A) – One Form A (4 pages) is required for each applicable person in your company. Copies of the Forms can be used and only need to be changed when the financial information changes. The certification signature and date must be original for each letting. Do not staple the forms together.

If you answered “NO” to all of the questions in Paragraph C (page 12), complete the first section (page 14) with your company information and then sign and date the Not Applicable statement on page 17.

Page 18 (Form B) - If you check “YES” to having other current or pending contracts it is acceptable to use the phrase, “See Affidavit of Availability on file”.

Page 20 (Workforce Projection) – Be sure to include the Duration of the Project. It is acceptable to use the phrase “Per Contract Specifications”.

Bid Bond – Submit your bid bond using the current Bid Bond Form provided in the proposal package. The Power of Attorney page should be stapled to the Bid Bond. If you are using an electronic bond, include your bid bond number on the form and attach the Proof of Insurance printed from the Surety 2000 Web Site.

Disadvantaged Business Utilization Plan and/or Good Faith Effort – The last item in your bid should be the DBE Utilization Plan (SBE 2026), DBE Participation Statement (SBE 2025) and supporting paperwork. If you have documentation for a Good Faith Effort, it should follow the SBE Forms.

The Bid Letting is now available in streaming Audio/Video from the IDOT Web Site. A link to the stream will be placed on the main page of the current letting on the day of the Letting. The stream will not begin until 10 AM. The actual reading of the bids does not begin until approximately 10:20 AM.

Following the Letting, the As-Read Tabulation of Bids will be posted by the end of the day. You will find the link on the main page of the current letting.

QUESTIONS: pre-letting up to execution of the contract

Contractor/Subcontractor pre-qualification -----217-782-3413
Small Business, Disadvantaged Business Enterprise (DBE) -----217-785-4611
Contracts, Bids, Letting process or Internet downloads-----217-785-0230
Estimates Unit -----217-785-3483

QUESTIONS: following contract execution

Including Subcontractor documentation, payments -----217-782-3413
Railroad Insurance -----217-785-0275

138

RETURN WITH BID

| |
|-----------------------|
| Proposal Submitted By |
| Name |
| Address |
| City |

Letting June 15, 2012

NOTICE TO PROSPECTIVE BIDDERS

This proposal can be used for bidding purposes by only those companies that request and receive written AUTHORIZATION TO BID from IDOT's Central Bureau of Construction. This does not apply to Small Business Set-Asides.

BIDDERS NEED NOT RETURN THE ENTIRE PROPOSAL

Notice to Bidders, Specifications, Proposal, Contract and Contract Bond



**Illinois Department
of Transportation**

Springfield, Illinois 62764

**Contract No. 76F72
Various Counties
Section DIST 8 GUARDRAIL 2013-1
Various Routes
District 8 Construction Funds**

PLEASE MARK THE APPROPRIATE BOX BELOW:

- A Bid Bond is included.
- A Cashier's Check or a Certified Check is included.

Plans Included
Herein

Prepared by

S

Checked by

(Printed by authority of the State of Illinois)

Page intentionally left blank

RETURN WITH BID



PROPOSAL

TO THE DEPARTMENT OF TRANSPORTATION

1. Proposal of _____

Taxpayer Identification Number (Mandatory) _____ a

for the improvement identified and advertised for bids in the Invitation for Bids as:

Contract No. 76F72
Various Counties
Section DIST 8 GUARDRAIL 2013-1
Various Routes
District 8 Construction Funds

This project consists of guardrail and cable rail repairs at various locations throughout District 8.

2. The undersigned bidder will furnish all labor, material and equipment to complete the above described project in a good and workmanlike manner as provided in the contract documents provided by the Department of Transportation. This proposal will become part of the contract and the terms and conditions contained in the contract documents shall govern performance and payments.

RETURN WITH BID

3. **ASSURANCE OF EXAMINATION AND INSPECTION/WAIVER.** The undersigned further declares that he/she has carefully examined the proposal, plans, specifications, addenda, form of contract and contract bond, and special provisions, and that he/she has inspected in detail the site of the proposed work, and that he/she has familiarized themselves with all of the local conditions affecting the contract and the detailed requirements of construction, and understands that in making this proposal he/she waives all right to plead any misunderstanding regarding the same.
4. **EXECUTION OF CONTRACT AND CONTRACT BOND.** The undersigned further agrees to execute a contract for this work and present the same to the department within fifteen (15) days after the contract has been mailed to him/her. The undersigned further agrees that he/she and his/her surety will execute and present within fifteen (15) days after the contract has been mailed to him/her contract bond satisfactory to and in the form prescribed by the Department of Transportation, in the penal sum of the full amount of the contract, guaranteeing the faithful performance of the work in accordance with the terms of the contract.
5. **PROPOSAL GUARANTY.** Accompanying this proposal is either a bid bond on the department form, executed by a corporate surety company satisfactory to the department, or a proposal guaranty check consisting of a bank cashier's check or a properly certified check for not less than 5 per cent of the amount bid or for the amount specified in the following schedule:

| <u>Amount of Bid</u> | | <u>Proposal Guaranty</u> | <u>Amount of Bid</u> | | <u>Proposal Guaranty</u> | |
|----------------------|----------------------|--------------------------|----------------------|----|--------------------------|-------------|
| Up to | \$5,000 | \$150 | \$2,000,000 | to | \$3,000,000 | \$100,000 |
| \$5,000 | to \$10,000 | \$300 | \$3,000,000 | to | \$5,000,000 | \$150,000 |
| \$10,000 | to \$50,000 | \$1,000 | \$5,000,000 | to | \$7,500,000 | \$250,000 |
| \$50,000 | to \$100,000 | \$3,000 | \$7,500,000 | to | \$10,000,000 | \$400,000 |
| \$100,000 | to \$150,000 | \$5,000 | \$10,000,000 | to | \$15,000,000 | \$500,000 |
| \$150,000 | to \$250,000 | \$7,500 | \$15,000,000 | to | \$20,000,000 | \$600,000 |
| \$250,000 | to \$500,000 | \$12,500 | \$20,000,000 | to | \$25,000,000 | \$700,000 |
| \$500,000 | to \$1,000,000 | \$25,000 | \$25,000,000 | to | \$30,000,000 | \$800,000 |
| \$1,000,000 | to \$1,500,000 | \$50,000 | \$30,000,000 | to | \$35,000,000 | \$900,000 |
| \$1,500,000 | to \$2,000,000 | \$75,000 | over | | \$35,000,000 | \$1,000,000 |

Bank cashier's checks or properly certified checks accompanying proposals shall be made payable to the Treasurer, State of Illinois, when the state is awarding authority; the county treasurer, when a county is the awarding authority; or the city, village, or town treasurer, when a city, village, or town is the awarding authority.

If a combination bid is submitted, the proposal guaranties which accompany the individual proposals making up the combination will be considered as also covering the combination bid.

The amount of the proposal guaranty check is _____ \$(_____). If this proposal is accepted and the undersigned shall fail to execute a contract bond as required herein, it is hereby agreed that the amount of the proposal guaranty shall become the property of the State of Illinois, and shall be considered as payment of damages due to delay and other causes suffered by the State because of the failure to execute said contract and contract bond; otherwise, the bid bond shall become void or the proposal guaranty check shall be returned to the undersigned.

Attach Cashier's Check or Certified Check Here

In the event that one proposal guaranty check is intended to cover two or more proposals, the amount must be equal to the sum of the proposal guaranties which would be required for each individual proposal. If the guaranty check is placed in another proposal, state below where it may be found.

The proposal guaranty check will be found in the proposal for:

Item _____

Section No. _____

County _____

Mark the proposal cover sheet as to the type of proposal guaranty submitted.

RETURN WITH BID

6. **COMBINATION BIDS.** The undersigned further agrees that if awarded the contract for the sections contained in the following combination, he/she will perform the work in accordance with the requirements of each individual proposal comprising the combination bid specified in the schedule below, and that the combination bid shall be prorated against each section in proportion to the bid submitted for the same. If an error is found to exist in the gross sum bid for one or more of the individual sections included in a combination, the combination bid shall be corrected as provided in the specifications.

When a combination bid is submitted, the schedule below must be completed in each proposal comprising the combination.

If alternate bids are submitted for one or more of the sections comprising the combination, a combination bid must be submitted for each alternate.

Schedule of Combination Bids

| Combination No. | Sections Included in Combination | Combination Bid | |
|-----------------|----------------------------------|-----------------|-------|
| | | Dollars | Cents |
| | | | |
| | | | |
| | | | |
| | | | |

7. **SCHEDULE OF PRICES.** The undersigned bidder submits herewith, in accordance with the rules and instructions, a schedule of prices for the items of work for which bids are sought. The unit prices bid are in U.S. dollars and cents, and all extensions and summations have been made. The bidder understands that the quantities appearing in the bid schedule are approximate and are provided for the purpose of obtaining a gross sum for the comparison of bids. If there is an error in the extension of the unit prices, the unit prices shall govern. Payment to the contractor awarded the contract will be made only for actual quantities of work performed and accepted or materials furnished according to the contract. The scheduled quantities of work to be done and materials to be furnished may be increased, decreased or omitted as provided elsewhere in the contract.

8. **AUTHORITY TO DO BUSINESS IN ILLINOIS.** Section 20-43 of the Illinois Procurement Code (30 ILCS 500/20-43) provides that a person (other than an individual acting as a sole proprietor) must be a legal entity authorized to do business in the State of Illinois prior to submitting the bid.

9. **The services of a subcontractor will or may be used.**

Check box Yes
 Check box No

For known subcontractors with subcontracts with an annual value of more than \$25,000, the contract shall include their name, address, and the dollar allocation for each subcontractor.

10. **EXECUTION OF CONTRACT:** The Department of Transportation will, in accordance with the rules governing Department procurements, execute the contract and shall be the sole entity having the authority to accept performance and make payments under the contract. Execution of the contract by the Chief Procurement Officer or the State Purchasing Officer is for approval of the procurement process and execution of the contract by the Department. Neither the Chief Procurement Officer nor the State Purchasing Officer shall be responsible for administration of the contract or determinations respecting performance or payment there under except as otherwise permitted in the Illinois Procurement Code.

ILLINOIS DEPARTMENT OF TRANSPORTATION
 SCHEDULE OF PRICES
 CONTRACT
 NUMBER - 76F72

State Job # - C-98-063-12

Project Number

Route

County Name - VARIOUS-

VARIOUS

Code - 0 - -

District - 0 - -

Section Number - DIST 8 GUARDRAIL 2013-1

| Item Number | Pay Item Description | Unit of Measure | Quantity | x | Unit Price | = | Total Price |
|-------------|-----------------------|-----------------|----------|---|------------|---|-------------|
| X0325972 | CABLE GUARD POST | EACH | 50.000 | | | | |
| X0326466 | HT CABLE POST REPAIR | EACH | 10.000 | | | | |
| X0326468 | MEDIAN CABLE | FOOT | 100.000 | | | | |
| X6300210 | GUARDRAIL BLOCKS | EACH | 300.000 | | | | |
| X6300215 | RAIL ELEMENT PLATES | EACH | 225.000 | | | | |
| X6300220 | EXTRUDER HEAD | EACH | 10.000 | | | | |
| X6300225 | SINGLE END SECTION | EACH | 2.000 | | | | |
| X6300230 | STEEL POSTS | EACH | 250.000 | | | | |
| X6300231 | STEEL POST ATTACH STR | EACH | 3.000 | | | | |
| X6331110 | STEEL POSTS SPECIAL | EACH | 10.000 | | | | |
| X8030110 | LOC UNDERGR CABLE SPL | EACH | 5.000 | | | | |
| Z0029655 | HT CBL ROAD GUARDPOST | EACH | 200.000 | | | | |
| Z0029658 | REP TB TERM T1 SP PST | EACH | 14.000 | | | | |
| Z0029662 | REPL HT CBL POST FDN | EACH | 5.000 | | | | |
| Z0050000 | REM REIN IMPACT ATTEN | EACH | 20.000 | | | | |

ILLINOIS DEPARTMENT OF TRANSPORTATION
 SCHEDULE OF PRICES
 CONTRACT
 NUMBER -

76F72

State Job # - C-98-063-12

Project Number

Route

County Name - VARIOUS-

VARIOUS

Code - 0 - -

District - 0 - -

Section Number - DIST 8 GUARDRAIL 2013-1

| Item Number | Pay Item Description | Unit of Measure | Quantity | x | Unit Price | = | Total Price |
|-------------|-----------------------|-----------------|----------|---|------------|---|-------------|
| Z0052410 | REPAIR TRBT T1 SP TAN | EACH | 44.000 | | | | |
| Z0052415 | REPAIR TRBT T1 SP FLR | EACH | 10.000 | | | | |
| Z0052600 | REPAIR TR BAR TERM T2 | EACH | 5.000 | | | | |
| Z0052800 | REPAIR TR BAR TERM 3A | EACH | 5.000 | | | | |
| Z0053000 | REPAIR TR BAR TERM T5 | EACH | 2.000 | | | | |
| Z0053200 | REPAIR TR BAR TERM T6 | EACH | 5.000 | | | | |
| Z0059660 | REP TB TERM T1 SP RLP | EACH | 7.000 | | | | |
| 63100041 | TRAF BAR TERM T1B | EACH | 5.000 | | | | |
| 63100045 | TRAF BAR TERM T2 | EACH | 3.000 | | | | |
| 63100070 | TRAF BAR TERM T5 | EACH | 2.000 | | | | |
| 63100085 | TRAF BAR TERM T6 | EACH | 6.000 | | | | |
| 63100167 | TR BAR TRM T1 SPL TAN | EACH | 64.000 | | | | |
| 63100169 | TR BAR TRM T1 SPL FLR | EACH | 5.000 | | | | |
| 64300260 | IMP ATTEN FRD NAR TL3 | EACH | 2.000 | | | | |
| 64300370 | IMP ATTEN FRD WID TL3 | EACH | 2.000 | | | | |

ILLINOIS DEPARTMENT OF TRANSPORTATION
 SCHEDULE OF PRICES
 CONTRACT
 NUMBER - 76F72

State Job # - C-98-063-12

Project Number

Route

County Name - VARIOUS--

VARIOUS

Code - 0 - -

District - 0 - -

Section Number - DIST 8 GUARDRAIL 2013-1

| Item Number | Pay Item Description | Unit of Measure | Quantity | x | Unit Price | = | Total Price |
|-------------|-----------------------|-----------------|----------|---|------------|---|-------------|
| 67100100 | MOBILIZATION | L SUM | 1.000 | | | | |
| 70100310 | TRAF CONT-PROT 701421 | L SUM | 1.000 | | | | |
| 70100450 | TRAF CONT-PROT 701201 | L SUM | 1.000 | | | | |
| 70100700 | TRAF CONT-PROT 701406 | L SUM | 1.000 | | | | |
| 70102635 | TR CONT & PROT 701701 | L SUM | 1.000 | | | | |
| 78201000 | TERMINAL MARKER - DA | EACH | 69.000 | | | | |

CONTRACT NUMBER

76F72

THIS IS THE TOTAL BID

\$ _____

NOTES:

1. Each PAY ITEM should have a UNIT PRICE and a TOTAL PRICE.
2. The UNIT PRICE shall govern if no TOTAL PRICE is shown or if there is a discrepancy between the product of the UNIT PRICE multiplied by the QUANTITY.
3. If a UNIT PRICE is omitted, the TOTAL PRICE will be divided by the QUANTITY in order to establish a UNIT PRICE.
4. A bid may be declared UNACCEPTABLE if neither a unit price nor a total price is shown.

RETURN WITH BID

STATE REQUIRED ETHICAL STANDARDS GOVERNING CONTRACT PROCUREMENT: ASSURANCES, CERTIFICATIONS AND DISCLOSURES

I. GENERAL

A. Article 50 of the Illinois Procurement Code establishes the duty of all State chief procurement officers, State purchasing officers, and their designees to maximize the value of the expenditure of public moneys in procuring goods, services, and contracts for the State of Illinois and to act in a manner that maintains the integrity and public trust of State government. In discharging this duty, they are charged by law to use all available information, reasonable efforts, and reasonable actions to protect, safeguard, and maintain the procurement process of the State of Illinois.

B. In order to comply with the provisions of Article 50 and to carry out the duty established therein, all bidders are to adhere to ethical standards established for the procurement process, and to make such assurances, disclosures and certifications required by law. Except as otherwise required in subsection III, paragraphs J-M, by execution of the Proposal Signature Sheet, the bidder indicates that each of the mandated assurances have been read and understood, that each certification is made and understood, and that each disclosure requirement has been understood and completed.

C. In addition to all other remedies provided by law, failure to comply with any assurance, failure to make any disclosure or the making of a false certification shall be grounds for the chief procurement officer to void the contract, or subcontract, and may result in the suspension or debarment of the bidder or subcontractor.

II. ASSURANCES

The assurances hereinafter made by the bidder are each a material representation of fact upon which reliance is placed should the Department enter into the contract with the bidder.

A. Conflicts of Interest

1. The Illinois Procurement Code provides in pertinent part:

Section 50-13. Conflicts of Interest.

(a) Prohibition. It is unlawful for any person holding an elective office in this State, holding a seat in the General Assembly, or appointed to or employed in any of the offices or agencies of state government and who receives compensation for such employment in excess of 60% of the salary of the Governor of the State of Illinois, or who is an officer or employee of the Capital Development Board or the Illinois Toll Highway Authority, or who is the spouse or minor child of any such person to have or acquire any contract, or any direct pecuniary interest in any contract therein, whether for stationery, printing, paper, or any services, materials, or supplies, that will be wholly or partially satisfied by the payment of funds appropriated by the General Assembly of the State of Illinois or in any contract of the Capital Development Board or the Illinois Toll Highway authority.

(b) Interests. It is unlawful for any firm, partnership, association or corporation, in which any person listed in subsection (a) is entitled to receive (i) more than 7 1/2% of the total distributable income or (ii) an amount in excess of the salary of the Governor, to have or acquire any such contract or direct pecuniary interest therein.

(c) Combined interests. It is unlawful for any firm, partnership, association, or corporation, in which any person listed in subsection (a) together with his or her spouse or minor children is entitled to receive (i) more than 15%, in the aggregate, of the total distributable income or (ii) an amount in excess of 2 times the salary of the Governor, to have or acquire any such contract or direct pecuniary interest therein.

(d) Securities. Nothing in this Section invalidates the provisions of any bond or other security previously offered or to be offered for sale or sold by or for the State of Illinois.

(e) Prior interests. This Section does not affect the validity of any contract made between the State and an officer or employee of the State or member of the General Assembly, his or her spouse, minor child or any combination of those persons if that contract was in existence before his or her election or employment as an officer, member, or employee. The contract is voidable, however, if it cannot be completed within 365 days after the officer, member, or employee takes office or is employed.

The current salary of the Governor is \$177,412.00. Sixty percent of the salary is \$106,447.20.

RETURN WITH BID

2. The bidder assures the Department that the award and execution of the contract would not cause a violation of Section 50-13, or that an effective exemption has been issued by the Board of Ethics to any individual subject to the Section 50-13 prohibitions pursuant to the provisions of Section 50-20 of the Code and Executive Order Number 3 (1998). Information concerning the exemption process is available from the Department upon request.

B. Negotiations

1. The Illinois Procurement Code provides in pertinent part:

Section 50-15. Negotiations.

(a) It is unlawful for any person employed in or on a continual contractual relationship with any of the offices or agencies of State government to participate in contract negotiations on behalf of that office or agency with any firm, partnership, association, or corporation with whom that person has a contract for future employment or is negotiating concerning possible future employment.

2. The bidder assures the Department that the award and execution of the contract would not cause a violation of Section 50-15, and that the bidder has no knowledge of any facts relevant to the kinds of acts prohibited therein.

C. Inducements

1. The Illinois Procurement Code provides:

Section 50-25. Inducement. Any person who offers or pays any money or other valuable thing to any person to induce him or her not to bid for a State contract or as recompense for not having bid on a State contract is guilty of a Class 4 felony. Any person who accepts any money or other valuable thing for not bidding for a State contract or who withholds a bid in consideration of the promise for the payment of money or other valuable thing is guilty of a Class 4 felony.

2. The bidder assures the Department that the award and execution of the contract would not cause a violation of Section 50-25, and that the bidder has no knowledge of any facts relevant to the kinds of acts prohibited therein.

D. Revolving Door Prohibition

1. The Illinois Procurement Code provides:

Section 50-30. Revolving door prohibition. Chief procurement officers, State purchasing officers, procurement compliance monitors, their designees whose principal duties are directly related to State procurement, and executive officers confirmed by the Senate are expressly prohibited for a period of 2 years after terminating an affected position from engaging in any procurement activity relating to the State agency most recently employing them in an affected position for a period of at least 6 months. The prohibition includes, but is not limited to: lobbying the procurement process; specifying; bidding; proposing bid, proposal, or contract documents; on their own behalf or on behalf of any firm, partnership, association, or corporation. This Section applies only to persons who terminate an affected position on or after January 15, 1999.

2. The bidder assures the Department that the award and execution of the contract would not cause a violation of Section 50-30, and that the bidder has no knowledge of any facts relevant to the kinds of acts prohibited therein.

E. Reporting Anticompetitive Practices

1. The Illinois Procurement Code provides:

Section 50-40. Reporting anticompetitive practices. When, for any reason, any vendor, bidder, contractor, chief procurement officer, State purchasing officer, designee, elected official, or State employee suspects collusion or other anticompetitive practice among any bidders, offerors, contractors, proposers, or employees of the State, a notice of the relevant facts shall be transmitted to the Attorney General and the chief procurement officer.

2. The bidder assures the Department that it has not failed to report any relevant facts concerning the practices addressed in Section 50-40 which may involve the contract for which the bid is submitted.

F. Confidentiality

1. The Illinois Procurement Code provides:

Section 50-45. Confidentiality. Any chief procurement officer, State purchasing officer, designee, or executive officer who willfully uses or allows the use of specifications, competitive bid documents, proprietary competitive information, proposals, contracts, or selection information to compromise the fairness or integrity of the procurement, bidding, or contract process shall be subject to immediate dismissal, regardless of the Personnel code, any contract, or any collective bargaining agreement, and may in addition be subject to criminal prosecution.

2. The bidder assures the Department that it has no knowledge of any fact relevant to the practices addressed in Section 50-45 which may involve the contract for which the bid is submitted.

RETURN WITH BID

G. Insider Information

1. The Illinois Procurement Act provides:

Section 50-50. Insider information. It is unlawful for any current or former elected or appointed State official or State employee to knowingly use confidential information available only by virtue of that office or employment for actual or anticipated gain for themselves or another person.

2. The bidder assures the Department that it has no knowledge of any facts relevant to the practices addressed in Section 50-50 which may involve the contract for which the bid is submitted.

III. CERTIFICATIONS

The certifications hereinafter made by the bidder are each a material representation of fact upon which reliance is placed should the Department enter into the contract with the bidder. Section 50-2 of the Illinois Procurement Code provides that every person that has entered into a multi-year contract and every subcontractor with a multi-year subcontract shall certify, by July 1 of each fiscal year covered by the contract after the initial fiscal year, to the responsible chief procurement officer whether it continues to satisfy the requirements of Article 50 pertaining to the eligibility for a contract award. If a contractor or subcontractor is not able to truthfully certify that it continues to meet all requirements, it shall provide with its certification a detailed explanation of the circumstances leading to the change in certification status. A contractor or subcontractor that makes a false statement material to any given certification required under Article 50 is, in addition to any other penalties or consequences prescribed by law, subject to liability under the Whistleblower Reward and Protection Act for submission of a false claim.

A. Bribery

1. The Illinois Procurement Code provides:

Section 50-5. Bribery.

(a) Prohibition. No person or business shall be awarded a contract or subcontract under this Code who:

(1) has been convicted under the laws of Illinois or any other state of bribery or attempting to bribe an officer or employee of the State of Illinois or any other state in that officer's or employee's official capacity; or

(2) has made an admission of guilt of that conduct that is a matter of record but has not been prosecuted for that conduct.

(b) Businesses. No business shall be barred from contracting with any unit of State or local government, or subcontracting under such a contract, as a result of a conviction under this Section of any employee or agent of the business if the employee or agent is no longer employed by the business and:

(1) the business has been finally adjudicated not guilty; or

(2) the business demonstrates to the governmental entity with which it seeks to contract, or which is signatory to the contract which the subcontract relates, and that entity finds that the commission of the offense was not authorized, requested, commanded, or performed by a director, officer, or high managerial agent on behalf of the business as provided in paragraph (2) of subsection (a) of Section 5-4 of the Criminal Code of 1961.

(c) Conduct on behalf of business. For purposes of this Section, when an official, agent, or employee of a business committed the bribery or attempted bribery on behalf of the business and in accordance with the direction or authorization of a responsible official of the business, the business shall be chargeable with the conduct.

(d) Certification. Every bid submitted to and contract executed by the State, and every subcontract subject to Section 20-120 of the Procurement Code shall contain a certification by the contractor or the subcontractor, respectively, that the contractor or subcontractor is not barred from being awarded a contract or subcontract under this Section and acknowledges that the chief procurement officer may declare the related contract void if any certifications required by this Section are false. A contractor who makes a false statement, material to the certification, commits a Class 3 felony.

2. The contractor or subcontractor certifies that it is not barred from being awarded a contract under Section 50.5.

B. Felons

1. The Illinois Procurement Code provides:

Section 50-10. Felons. Unless otherwise provided, no person or business convicted of a felony shall do business with the State of Illinois or any State agency, or enter into a subcontract, from the date of conviction until 5 years after the date of completion of the sentence for that felony, unless no person held responsible by a prosecutorial office for the facts upon which the conviction was based continues to have any involvement with the business.

2. Certification. Every bid submitted to and contract executed by the State and every subcontract subject to Section 20-120 of the Procurement Code shall contain a certification by the bidder or contractor or subcontractor, respectively, that the bidder, contractor, or subcontractor is not barred from being awarded a contract or subcontract under this Section and acknowledges that the chief procurement officer may declare the related contract void if any of the certifications required by this Section are false.

RETURN WITH BID

C. Debt Delinquency

1. The Illinois Procurement Code provides:

Section 50-11 and 50-12. Debt Delinquency.

The contractor or bidder or subcontractor, respectively, certifies that it, or any affiliate, is not barred from being awarded a contract or subcontract under the Procurement Code. Section 50-11 prohibits a person from entering into a contract with a State agency, or entering into a subcontract, if it knows or should know that it, or any affiliate, is delinquent in the payment of any debt to the State as defined by the Debt Collection Board. Section 50-12 prohibits a person from entering into a contract with a State agency, or entering into a subcontract, if it, or any affiliate, has failed to collect and remit Illinois Use Tax on all sales of tangible personal property into the State of Illinois in accordance with the provisions of the Illinois Use Tax Act. The bidder or contractor or subcontractor, respectively, further acknowledges that the chief procurement officer may declare the related contract void if this certification is false or if the bidder, contractor, or subcontractor, or any affiliate, is determined to be delinquent in the payment of any debt to the State during the term of the contract.

D. Prohibited Bidders, Contractors and Subcontractors

1. The Illinois Procurement Code provides:

Section 50-10.5 and 50-60(c). Prohibited bidders, contractors and subcontractors.

The bidder or contractor or subcontractor, respectively, certifies in accordance with 30 ILCS 500/50-10.5 that no officer, director, partner or other managerial agent of the contracting business has been convicted of a felony under the Sarbanes-Oxley Act of 2002 or a Class 3 or Class 2 felony under the Illinois Securities Law of 1953 or if in violation of Subsection (c) for a period of five years from the date of conviction. Every bid submitted to and contract executed by the State and every subcontract subject to Section 20-120 of the Procurement Code shall contain a certification by the bidder, contractor, or subcontractor, respectively, that the bidder, contractor, or subcontractor is not barred from being awarded a contract or subcontract under this Section and acknowledges that the chief procurement officer shall declare the related contract void if any of the certifications completed pursuant to this Section are false.

E. Section 42 of the Environmental Protection Act

The bidder or contractor or subcontractor, respectively, certifies in accordance with 30 ILCS 500/50-12 that the bidder, contractor, or subcontractor, is not barred from being awarded a contract or entering into a subcontract under this Section which prohibits the bidding on or entering into contracts with the State of Illinois or a State agency, or entering into any subcontract, that is subject to the Procurement Code by a person or business found by a court or the Pollution Control Board to have committed a willful or knowing violation of Section 42 of the Environmental Protection Act for a period of five years from the date of the order. The bidder or contractor or subcontractor, respectively, acknowledges that the chief procurement officer may declare the contract void if this certification is false.

F. Educational Loan

1. Section 3 of the Educational Loan Default Act provides:

§ 3. No State agency shall contract with an individual for goods or services if that individual is in default, as defined in Section 2 of this Act, on an educational loan. Any contract used by any State agency shall include a statement certifying that the individual is not in default on an educational loan as provided in this Section.

2. The bidder, if an individual as opposed to a corporation, partnership or other form of business organization, certifies that the bidder is not in default on an educational loan as provided in Section 3 of the Act.

G. Bid-Rigging/Bid Rotating

1. Section 33E-11 of the Criminal Code of 1961 provides:

§ 33E-11. (a) Every bid submitted to and public contract executed pursuant to such bid by the State or a unit of local government shall contain a certification by the prime contractor that the prime contractor is not barred from contracting with any unit of State or local government as a result of a violation of either Section 33E-3 or 33E-4 of this Article. The State and units of local government shall provide the appropriate forms for such certification.

- (b) A contractor who makes a false statement, material to the certification, commits a Class 3 felony.

A violation of Section 33E-3 would be represented by a conviction of the crime of bid-rigging which, in addition to Class 3 felony sentencing, provides that any person convicted of this offense or any similar offense of any state or the United States which contains the same elements as this offense shall be barred for 5 years from the date of conviction from contracting with any unit of State or local government. No corporation shall be barred from contracting with any unit of State or local government as a result of a conviction under this Section of any employee or agent of such corporation if the employee so convicted is no longer employed by the corporation and: (1) it has been finally adjudicated not guilty or (2) if it demonstrates to the governmental entity with which it seeks to contract and that entity finds that the commission of the offense was neither authorized, requested, commanded, nor performed by a director, officer or a high managerial agent in behalf of the corporation.

RETURN WITH BID

A violation of Section 33E-4 would be represented by a conviction of the crime of bid-rotating which, in addition to Class 2 felony sentencing, provides that any person convicted of this offense or any similar offense of any state or the United States which contains the same elements as this offense shall be permanently barred from contracting with any unit of State or local government. No corporation shall be barred from contracting with any unit of State or local government as a result of a conviction under this Section of any employee or agent of such corporation if the employee so convicted is no longer employed by the corporation and: (1) it has been finally adjudicated not guilty or (2) if it demonstrates to the governmental entity with which it seeks to contract and that entity finds that the commission of the offense was neither authorized, requested, commanded, nor performed by a director, officer or a high managerial agent in behalf of the corporation.

2. The bidder certifies that it is not barred from contracting with the Department by reason of a violation of either Section 33E-3 or Section 33E-4.

H. International Anti-Boycott

1. Section 5 of the International Anti-Boycott Certification Act provides:

§ 5. State contracts. Every contract entered into by the State of Illinois for the manufacture, furnishing, or purchasing of supplies, material, or equipment or for the furnishing of work, labor, or services, in an amount exceeding the threshold for small purchases according to the purchasing laws of this State or \$10,000.00, whichever is less, shall contain certification, as a material condition of the contract, by which the contractor agrees that neither the contractor nor any substantially-owned affiliated company is participating or shall participate in an international boycott in violation of the provisions of the U.S. Export Administration Act of 1979 or the regulations of the U.S. Department of Commerce promulgated under that Act.

2. The bidder makes the certification set forth in Section 5 of the Act.

I. Drug Free Workplace

1. The Illinois "Drug Free Workplace Act" applies to this contract and it is necessary to comply with the provisions of the "Act" if the contractor is a corporation, partnership, or other entity (including a sole proprietorship) which has 25 or more employees.

2. The bidder certifies that if awarded a contract in excess of \$5,000 it will provide a drug free workplace by:

(a) Publishing a statement notifying employees that the unlawful manufacture, distribution, dispensation, possession or use of a controlled substance, including cannabis, is prohibited in the contractor's workplace; specifying the actions that will be taken against employees for violations of such prohibition; and notifying the employee that, as a condition of employment on such contract, the employee shall abide by the terms of the statement, and notify the employer of any criminal drug statute conviction for a violation occurring in the workplace no later than five (5) days after such conviction.

(b) Establishing a drug free awareness program to inform employees about the dangers of drug abuse in the workplace; the contractor's policy of maintaining a drug free workplace; any available drug counseling, rehabilitation, and employee assistance programs; and the penalties that may be imposed upon employees for drug violations.

(c) Providing a copy of the statement required by subparagraph (1) to each employee engaged in the performance of the contract and to post the statement in a prominent place in the workplace.

(d) Notifying the Department within ten (10) days after receiving notice from an employee or otherwise receiving actual notice of the conviction of an employee for a violation of any criminal drug statute occurring in the workplace.

(e) Imposing or requiring, within 30 days after receiving notice from an employee of a conviction or actual notice of such a conviction, an appropriate personnel action, up to and including termination, or the satisfactory participation in a drug abuse assistance or rehabilitation program approved by a federal, state or local health, law enforcement or other appropriate agency.

(f) Assisting employees in selecting a course of action in the event drug counseling, treatment, and rehabilitation is required and indicating that a trained referral team is in place.

(g) Making a good faith effort to continue to maintain a drug free workplace through implementation of the actions and efforts stated in this certification.

RETURN WITH BID

J. Disclosure of Business Operations in Iran

Section 50-36 of the Illinois Procurement Code, 30ILCS 500/50-36 provides that each bid, offer, or proposal submitted for a State contract shall include a disclosure of whether or not the Company acting as the bidder, offeror, or proposing entity, or any of its corporate parents or subsidiaries, within the 24 months before submission of the bid, offer, or proposal had business operations that involved contracts with or provision of supplies or services to the Government of Iran, companies in which the Government of Iran has any direct or indirect equity share, consortiums or projects commissioned by the Government of Iran, or companies involved in consortiums or projects commissioned by the Government of Iran and either of the following conditions apply:

- (1) More than 10% of the Company's revenues produced in or assets located in Iran involve oil-related activities or mineral-extraction activities; less than 75% of the Company's revenues produced in or assets located in Iran involve contracts with or provision of oil-related or mineral-extraction products or services to the Government of Iran or a project or consortium created exclusively by that government; and the Company has failed to take substantial action.
- (2) The Company has, on or after August 5, 1996, made an investment of \$20 million or more, or any combination of investments of at least \$10 million each that in the aggregate equals or exceeds \$20 million in any 12-month period, which directly or significantly contributes to the enhancement of Iran's ability to develop petroleum resources of Iran.

The terms "Business operations", "Company", "Mineral-extraction activities", "Oil-related activities", "Petroleum resources", and "Substantial action" are all defined in the Code.

Failure to make the disclosure required by the Code shall cause the bid, offer or proposal to be considered not responsive. The disclosure will be considered when evaluating the bid, offer, or proposal or awarding the contract. The name of each Company disclosed as doing business or having done business in Iran will be provided to the State Comptroller.

Check the appropriate statement:

Company has no business operations in Iran to disclose.

Company has business operations in Iran as disclosed the attached document.

K. Apprenticeship and Training Certification (Does not apply to federal aid projects)

In accordance with the provisions of Section 30-22 (6) of the Illinois Procurement Code, the bidder certifies that it is a participant, either as an individual or as part of a group program, in the approved apprenticeship and training programs applicable to each type of work or craft that the bidder will perform with its own forces. The bidder further certifies for work that will be performed by subcontract that each of its subcontractors submitted for approval either (a) is, at the time of such bid, participating in an approved, applicable apprenticeship and training program; or (b) will, prior to commencement of performance of work pursuant to this contract, begin participation in an approved apprenticeship and training program applicable to the work of the subcontract. The Department, at any time before or after award, may require the production of a copy of each applicable Certificate of Registration issued by the United States Department of Labor evidencing such participation by the contractor and any or all of its subcontractors. Applicable apprenticeship and training programs are those that have been approved and registered with the United States Department of Labor. The bidder shall list in the space below, the official name of the program sponsor holding the Certificate of Registration for all of the types of work or crafts in which the bidder is a participant and that will be performed with the bidder's forces. Types of work or craft work that will be subcontracted shall be included and listed as subcontract work. The list shall also indicate any type of work or craft job category that does not have an applicable apprenticeship or training program. **The bidder is responsible for making a complete report and shall make certain that each type of work or craft job category that will be utilized on the project as reported on the Construction Employee Workforce Projection (Form BC-1256) and returned with the bid is accounted for and listed.**

The requirements of this certification and disclosure are a material part of the contract, and the contractor shall require this certification provision to be included in all approved subcontracts. In order to fulfill this requirement, it shall not be necessary that an applicable program sponsor be currently taking or that it will take applications for apprenticeship, training or employment during the performance of the work of this contract.

TO BE RETURNED WITH BID

L. Political Contributions and Registration with the State Board of Elections

Sections 20-160 and 50-37 of the Illinois Procurement Code regulate political contributions from business entities and any affiliated entities or affiliated persons bidding on or contracting with the state. Generally under Section 50-37, any business entity, and any affiliated entity or affiliated person of the business entity, whose current year contracts with all state agencies exceed an awarded value of \$50,000, are prohibited from making any contributions to any political committees established to promote the candidacy of the officeholder responsible for the awarding of the contracts or any other declared candidate for that office for the duration of the term of office of the incumbent officeholder or a period 2 years after the termination of the contract, whichever is longer. Any business entity and affiliated entities or affiliated persons whose state contracts in the current year do not exceed an awarded value of \$50,000, but whose aggregate pending bids and proposals on state contracts exceed \$50,000, either alone or in combination with contracts not exceeding \$50,000, are prohibited from making any political contributions to any political committee established to promote the candidacy of the officeholder responsible for awarding the pending contract during the period beginning on the date the invitation for bids or request for proposals is issued and ending on the day after the date of award or selection if the entity was not awarded or selected. Section 20-160 requires certification of registration of affected business entities in accordance with procedures found in Section 9-35 of The Election Code.

By submission of a bid, the contractor business entity acknowledges and agrees that it has read and understands Sections 20-160 and 50-37 of the Illinois Procurement Code, and that it makes the following certification:

The undersigned business entity certifies that it has registered as a business with the State Board of Elections and acknowledges a continuing duty to update the registration in accordance with the above referenced statutes. A copy of the certificate of registration shall be submitted with the bid. The bidder is cautioned that the Department will not award a contract without submission of the certificate of registration.

These requirements and compliance with the above referenced statutory sections are a material part of the contract, and any breach thereof shall be cause to void the contract under Section 50-60 of the Illinois Procurement Code. This provision does not apply to Federal-aid contracts.

M. Lobbyist Disclosure

Section 50-38 of the Illinois Procurement Code requires that any bidder or offeror on a State contract that hires a person required to register under the Lobbyist Registration Act to assist in obtaining a contract shall:

- (i) Disclose all costs, fees, compensation, reimbursements, and other remunerations paid or to be paid to the lobbyist related to the contract,
- (ii) Not bill or otherwise cause the State of Illinois to pay for any of the lobbyist's costs, fees, compensation, reimbursements, or other remuneration, and
- (iii) Sign a verification certifying that none of the lobbyist's costs, fees, compensation, reimbursements, or other remuneration were billed to the State.

This information, along with all supporting documents, shall be filed with the agency awarding the contract and with the Secretary of State. The chief procurement officer shall post this information, together with the contract award notice, in the online Procurement Bulletin.

Pursuant to Subsection (c) of this Section, no person or entity shall retain a person or entity to attempt to influence the outcome of a procurement decision made under the Procurement Code for compensation contingent in whole or in part upon the decision or procurement. Any person who violates this subsection is guilty of a business offense and shall be fined not more than \$10,000.

Bidder acknowledges that it is required to disclose the hiring of any person required to register pursuant to the Illinois Lobbyist Registration Act (25 ILCS 170) in connection with this contract.

Bidder has not hired any person required to register pursuant to the Illinois Lobbyist Registration Act in connection with this contract.

Or

Bidder has hired the following persons required to register pursuant to the Illinois Lobbyist Registration Act in connection with the contract:

Name and address of person: _____
All costs, fees, compensation, reimbursements and other remuneration paid to said person: _____

RETURN WITH BID

IV. DISCLOSURES

- A. The disclosures hereinafter made by the bidder are each a material representation of fact upon which reliance is placed should the Department enter into the contract with the bidder. The bidder further certifies that the Department has received the disclosure forms for each bid.

The chief procurement officer may void the bid, contract, or subcontract, respectively, if it is later determined that the bidder or subcontractor rendered a false or erroneous disclosure. A contractor or subcontractor may be suspended or debarred for violations of the Procurement Code. Furthermore, the chief procurement officer may void the contract and the surety providing the performance bond shall be responsible for completion of the contract.

B. Financial Interests and Conflicts of Interest

1. Section 50-35 of the Illinois Procurement Code provides that all bids of more than \$25,000 shall be accompanied by disclosure of the financial interests of the bidder. This disclosed information for the successful bidder, will be maintained as public information subject to release by request pursuant to the Freedom of Information Act, filed with the Procurement Policy Board, and shall be incorporated as a material term of the contract. Furthermore, pursuant to Section 5-5, the Procurement Policy Board may review a proposal, bid, or contract and issue a recommendation to void a contract or reject a proposal or bid based on any violation of the Procurement Code or the existence of a conflict of interest as provided in subsections (b) and (d) of Section 50-35.

The financial interests to be disclosed shall include ownership or distributive income share that is in excess of 5%, or an amount greater than 60% of the annual salary of the Governor, of the bidding entity or its parent entity, whichever is less, unless the contractor or bidder is a publicly traded entity subject to Federal 10K reporting, in which case it may submit its 10K disclosure in place of the prescribed disclosure. If a bidder is a privately held entity that is exempt from Federal 10K reporting, but has more than 200 shareholders, it may submit the information that Federal 10K companies are required to report, and list the names of any person or entity holding any ownership share that is in excess of 5%. The disclosure shall include the names, addresses, and dollar or proportionate share of ownership of each person making the disclosure, their instrument of ownership or beneficial relationship, and notice of any potential conflict of interest resulting from the current ownership or beneficial interest of each person making the disclosure having any of the relationships identified in Section 50-35 and on the disclosure form.

The current annual salary of the Governor is \$177,412.00

In addition, all disclosures shall indicate any other current or pending contracts, proposals, leases, or other ongoing procurement relationships the bidding entity has with any other unit of state government and shall clearly identify the unit and the contract, proposal, lease, or other relationship.

2. Disclosure Forms. Disclosure Form A is attached for use concerning the individuals meeting the above ownership or distributive share requirements. A separate Disclosure Form A must be submitted with the bid for each individual meeting the above requirements. In addition, a second form (Disclosure Form B) provides for the disclosure of current or pending procurement relationships with other (non-IDOT) state agencies and a total ownership certification. **The forms must be included with each bid.**

C. Disclosure Form Instructions

Form A Instructions for Financial Information & Potential Conflicts of Interest

If the bidder is a publicly traded entity subject to Federal 10K reporting, the 10K Report may be submitted to meet the requirements of Form A. If a bidder is a privately held entity that is exempt from Federal 10K reporting, but has more than 200 shareholders, it may submit the information that Federal 10K companies are required to report, and list the names of any person or entity holding any ownership share that is in excess of 5%. If a bidder is not subject to Federal 10K reporting, the bidder must determine if any individuals are required by law to complete a financial disclosure form. To do this, the bidder should answer each of the following questions. A "YES" answer indicates Form A must be completed. If the answer to each of the following questions is "NO", then the NOT APPLICABLE STATEMENT on Form A must be signed and dated by a person that is authorized to execute contracts for the bidding company. Note: These questions are for assistance only and are not required to be completed.

1. Does anyone in your organization have a direct or beneficial ownership share of greater than 5% of the bidding entity or parent entity? YES ___ NO ___
2. Does anyone in your organization have a direct or beneficial ownership share of less than 5%, but which has a value greater than 60% of the annual salary of the Governor? YES ___ NO ___
3. Does anyone in your organization receive more than 60% of the annual salary of the Governor of the bidding entity's or parent entity's distributive income? YES ___ NO ___

(Note: Distributive income is, for these purposes, any type of distribution of profits. An annual salary is not distributive income.)

4. Does anyone in your organization receive greater than 5% of the bidding entity's or parent entity's total distributive income, but which is less than 60% of the annual salary of the Governor? YES ___ NO ___

(Note: Only one set of forms needs to be completed per person per bid even if a specific individual would require a yes answer to more than one question.)

A "YES" answer to any of these questions requires the completion of Form A. The bidder must determine each individual in the bidding entity or the bidding entity's parent company that would cause the questions to be answered "Yes". Each form must be signed and dated by a person that is authorized to execute contracts for your organization. **Photocopied or stamped signatures are not acceptable.** The person signing can be, but does not have to be, the person for which the form is being completed. The bidder is responsible for the accuracy of any information provided.

If the answer to each of the above questions is "NO", then the NOT APPLICABLE STATEMENT of Form A must be signed and dated by a person that is authorized to execute contracts for your company.

RETURN WITH BID

Form B: Instructions for Identifying Other Contracts & Procurement Related Information

Disclosure Form B must be completed for each bid submitted by the bidding entity. *Note: Checking the NOT APPLICABLE STATEMENT on Form A does not allow the bidder to ignore Form B. Form B must be completed, checked, and dated or the bidder may be considered nonresponsive and the bid will not be accepted.*

The Bidder shall identify, by checking Yes or No on Form B, whether it has any pending contracts (including leases), bids, proposals, or other ongoing procurement relationship with any other (non-IDOT) State of Illinois agency. If "No" is checked, the bidder only needs to complete the check box on the bottom of Form B. If "Yes" is checked, the bidder must do one of the following:

Option I: If the bidder did not submit an Affidavit of Availability to obtain authorization to bid, the bidder must list all non-IDOT State of Illinois agency pending contracts, leases, bids, proposals, and other ongoing procurement relationships. These items may be listed on Form B or on an attached sheet(s). Do not include IDOT contracts. Contracts with cities, counties, villages, etc. are not considered State of Illinois agency contracts and are not to be included. Contracts with other State of Illinois agencies such as the Department of Natural Resources or the Capital Development Board must be included. Bidders who submit Affidavits of Availability are suggested to use Option II.

Option II: If the bidder is required and has submitted an Affidavit of Availability in order to obtain authorization to bid, the bidder may write or type "See Affidavit of Availability" which indicates that the Affidavit of Availability is incorporated by reference and includes all non-IDOT State of Illinois agency pending contracts, leases, bids, proposals, and other ongoing procurement relationships. For any contracts that are not covered by the Affidavit of Availability, the bidder must identify them on Form B or on an attached sheet(s). These might be such things as leases.

**ILLINOIS DEPARTMENT
OF TRANSPORTATION**

**Form A
Financial Information &
Potential Conflicts of Interest
Disclosure**

| | | |
|------------------|---------------|---------------------------|
| Contractor Name | | |
| Legal Address | | |
| City, State, Zip | | |
| Telephone Number | Email Address | Fax Number (if available) |

Disclosure of the information contained in this Form is required by the Section 50-35 of the Illinois Procurement Code (30 ILCS 500). Vendors desiring to enter into a contract with the State of Illinois must disclose the financial information and potential conflict of interest information as specified in this Disclosure Form. This information shall become part of the publicly available contract file. This Form A must be completed for bids in excess of \$25,000, and for all open-ended contracts. **A publicly traded company may submit a 10K disclosure (or equivalent if applicable) in satisfaction of the requirements set forth in Form A. See Disclosure Form Instructions.**

The current annual salary of the Governor is \$177,412.00.

DISCLOSURE OF FINANCIAL INFORMATION

1. Disclosure of Financial Information. The individual named below has an interest in the BIDDER (or its parent) in terms of ownership or distributive income share in excess of 5%, or an interest which has a value of more than 60% of the annual salary of the Governor. **(Make copies of this form as necessary and attach a separate Disclosure Form A for each individual meeting these requirements)**

| | |
|---|-------|
| FOR INDIVIDUAL (type or print information) | |
| NAME: | _____ |
| ADDRESS | _____ |
| Type of ownership/distributable income share: | |
| stock _____ sole proprietorship _____ Partnership _____ other: (explain on separate sheet): | |
| % or \$ value of ownership/distributable income share: | _____ |

2. Disclosure of Potential Conflicts of Interest. Check "Yes" or "No" to indicate which, if any, of the following potential conflict of interest relationships apply. If the answer to any question is "Yes", please attach additional pages and describe.

(a) State employment, currently or in the previous 3 years, including contractual employment of services. Yes ___ No ___

If your answer is yes, please answer each of the following questions.

1. Are you currently an officer or employee of either the Capitol Development Board or the Illinois State Toll Highway Authority? Yes ___ No ___

2. Are you currently appointed to or employed by any agency of the State of Illinois? If you are currently appointed to or employed by any agency of the State of Illinois, and your annual salary exceeds 60% of the annual salary of the Governor, provide the name the State agency for which you are employed and your annual salary. _____

RETURN WITH BID

3. If you are currently appointed to or employed by any agency of the State of Illinois, and your annual salary exceeds 60% of the annual salary of the Governor, are you entitled to receive (i) more than 7 1/2% of the total distributable income of your firm, partnership, association or corporation, or (ii) an amount in excess of 100% of the annual salary of the Governor?
Yes ___ No ___

4. If you are currently appointed to or employed by any agency of the State of Illinois, and your annual salary exceeds 60% of the annual salary of the Governor, are you and your spouse or minor children entitled to receive (i) more than 15 % in the aggregate of the total distributable income of your firm, partnership, association or corporation, or (ii) an amount in excess of two times the salary of the Governor?
Yes ___ No ___

(b) State employment of spouse, father, mother, son, or daughter, including contractual employment services in the previous 2 years.

Yes ___ No ___

If your answer is yes, please answer each of the following questions.

1. Is your spouse or any minor children currently an officer or employee of the Capitol Development Board or the Illinois State Toll Highway Authority?
Yes ___ No ___

2. Is your spouse or any minor children currently appointed to or employed by any agency of the State of Illinois? If your spouse or minor children is/are currently appointed to or employed by any agency of the State of Illinois, and his/her annual salary exceeds 60% of the annual salary of the Governor, provide the name of your spouse and/or minor children, the name of the State agency for which he/she is employed and his/her annual salary. _____

3. If your spouse or any minor children is/are currently appointed to or employed by any agency of the State of Illinois, and his/her annual salary exceeds 60% of the annual salary of the Governor, are you entitled to receive (i) more than 7 1/2% of the total distributable income of your firm, partnership, association or corporation, or (ii) an amount in excess of 100% of the annual salary of the Governor?
Yes ___ No ___

4. If your spouse or any minor children are currently appointed to or employed by any agency of the State of Illinois, and his/her annual salary exceeds 60% of the annual salary of the Governor, are you and your spouse or minor children entitled to receive (i) more than 15 % in the aggregate of the total distributable income of your firm, partnership, association or corporation, or (ii) an amount in excess of 2 times the salary of the Governor?
Yes ___ No ___

(c) Elective status; the holding of elective office of the State of Illinois, the government of the United States, any unit of local government authorized by the Constitution of the State of Illinois or the statutes of the State of Illinois currently or in the previous 3 years.
Yes ___ No ___

(d) Relationship to anyone holding elective office currently or in the previous 2 years; spouse, father, mother, son, or daughter.
Yes ___ No ___

(e) Appointive office; the holding of any appointive government office of the State of Illinois, the United States of America, or any unit of local government authorized by the Constitution of the State of Illinois or the statutes of the State of Illinois, which office entitles the holder to compensation in excess of the expenses incurred in the discharge of that office currently or in the previous 3 years.
Yes ___ No ___

(f) Relationship to anyone holding appointive office currently or in the previous 2 years; spouse, father, mother, son, or daughter.
Yes ___ No ___

(g) Employment, currently or in the previous 3 years, as or by any registered lobbyist of the State government.
Yes ___ No ___

RETURN WITH BID

(h) Relationship to anyone who is or was a registered lobbyist in the previous 2 years; spouse, father, mother, son, or daughter. Yes ___ No ___

(i) Compensated employment, currently or in the previous 3 years, by any registered election or reelection committee registered with the Secretary of State or any county clerk of the State of Illinois, or any political action committee registered with either the Secretary of State or the Federal Board of Elections. Yes ___ No ___

(j) Relationship to anyone; spouse, father, mother, son, or daughter; who was a compensated employee in the last 2 years by any registered election or re-election committee registered with the Secretary of State or any county clerk of the State of Illinois, or any political action committee registered with either the Secretary of State or the Federal Board of Elections. Yes ___ No ___

3. Communication Disclosure.

Disclose the name and address of each lobbyist and other agent of the bidder or offeror who is not identified in Section 2 of this form, who is has communicated, is communicating, or may communicate with any State officer or employee concerning the bid or offer. This disclosure is a continuing obligation and must be promptly supplemented for accuracy throughout the process and throughout the term of the contract. If no person is identified, enter "None" on the line below:

Name and address of person(s): _____

RETURN WITH BID

4. Debarment Disclosure. For each of the persons identified under Sections 2 and 3 of this form, disclose whether any of the following has occurred within the previous 10 years: debarment from contracting with any governmental entity; professional licensure discipline; bankruptcies; adverse civil judgments and administrative findings; and criminal felony convictions. This disclosure is a continuing obligation and must be promptly supplemented for accuracy throughout the procurement process and term of the contract. If no person is identified, enter "None" on the line below:

Name of person(s): _____

Nature of disclosure: _____

APPLICABLE STATEMENT

This Disclosure Form A is submitted on behalf of the INDIVIDUAL named on previous page. Under penalty of perjury, I certify the contents of this disclosure to be true and accurate to the best of my knowledge.

Completed by: _____ Date _____
Signature of Individual or Authorized Representative

NOT APPLICABLE STATEMENT

Under penalty of perjury, I have determined that no individuals associated with this organization meet the criteria that would require the completion of this Form A.

This Disclosure Form A is submitted on behalf of the CONTRACTOR listed on the previous page.

_____ Date _____
Signature of Authorized Representative

The bidder has a continuing obligation to supplement these disclosures under Sec. 50-35 of the Procurement Code.

RETURN WITH BID

ILLINOIS DEPARTMENT OF TRANSPORTATION

Form B Other Contracts & Financial Related Information Disclosure

Contractor Name, Legal Address, City, State, Zip, Telephone Number, Email Address, Fax Number (if available)

Disclosure of the information contained in this Form is required by the Section 50-35 of the Illinois Procurement Act (30 ILCS 500). This information shall become part of the publicly available contract file. This Form B must be completed for bids in excess of \$25,000, and for all open-ended contracts.

DISCLOSURE OF OTHER CONTRACTS AND PROCUREMENT RELATED INFORMATION

1. Identifying Other Contracts & Procurement Related Information. The BIDDER shall identify whether it has any pending contracts (including leases), bids, proposals, or other ongoing procurement relationship with any other State of Illinois agency: Yes ___ No ___

If "No" is checked, the bidder only needs to complete the signature box on the bottom of this page.

2. If "Yes" is checked. Identify each such relationship by showing State of Illinois agency name and other descriptive information such as bid or project number (attach additional pages as necessary). SEE DISCLOSURE FORM INSTRUCTIONS:

THE FOLLOWING STATEMENT MUST BE CHECKED

Signature of Authorized Representative, Date

OWNERSHIP CERTIFICATION

Please certify that the following statement is true if the individuals for all submitted Form A disclosures do not total 100% of ownership.

Any remaining ownership interest is held by individuals receiving less than \$106,447.20 of the bidding entity's or parent entity's distributive income or holding less than a 5% ownership interest.

Yes No N/A (Form A disclosure(s) established 100% ownership)

RETURN WITH BID

SPECIAL NOTICE TO CONTRACTORS

The following requirements of the Illinois Department of Human Rights' Rules and Regulations are applicable to bidders on all construction contracts advertised by the Illinois Department of Transportation:

CONSTRUCTION EMPLOYEE UTILIZATION PROJECTION

- (a) All bidders on construction contracts shall complete and submit, along with and as part of their bids, a Bidder's Employee Utilization Form (Form BC-1256) setting forth a projection and breakdown of the total workforce intended to be hired and/or allocated to such contract work by the bidder including a projection of minority and female employee utilization in all job classifications on the contract project.
- (b) The Department of Transportation shall review the Employee Utilization Form, and workforce projections contained therein, of the contract awardee to determine if such projections reflect an underutilization of minority persons and/or women in any job classification in accordance with the Equal Employment Opportunity Clause and Section 7.2 of the Illinois Department of Human Rights' Rules and Regulations for Public Contracts adopted as amended on September 17, 1980. If it is determined that the contract awardee's projections reflect an underutilization of minority persons and/or women in any job classification, it shall be advised in writing of the manner in which it is underutilizing and such awardee shall be considered to be in breach of the contract unless, prior to commencement of work on the contract project, it submits revised satisfactory projections or an acceptable written affirmative action plan to correct such underutilization including a specific timetable geared to the completion stages of the contract.
- (c) The Department of Transportation shall provide to the Department of Human Rights a copy of the contract awardee's Employee Utilization Form, a copy of any required written affirmative action plan, and any written correspondence related thereto. The Department of Human Rights may review and revise any action taken by the Department of Transportation with respect to these requirements.



Contract No. 76F72
Various Counties
Section DIST 8 GUARDRAIL 2013-1
Various Routes
District 8 Construction Funds

PART I. IDENTIFICATION

Dept. Human Rights # _____ Duration of Project: _____

Name of Bidder: _____

PART II. WORKFORCE PROJECTION

A. The undersigned bidder has analyzed minority group and female populations, unemployment rates and availability of workers for the location in which this contract work is to be performed, and for the locations from which the bidder recruits employees, and hereby submits the following workforce projection including a projection for minority and female employee utilization in all job categories in the workforce to be allocated to this contract:

TABLE A

Table with 14 columns: JOB CATEGORIES, TOTAL EMPLOYEES (M, F), MINORITY EMPLOYEES (BLACK, HISPANIC, *OTHER MINOR. (M, F)), and TRAINEES (APPRENTICES, ON THE JOB TRAINEES (M, F)). Rows include OFFICIALS (MANAGERS), SUPERVISORS, FOREMEN, CLERICAL, EQUIPMENT OPERATORS, MECHANICS, TRUCK DRIVERS, IRONWORKERS, CARPENTERS, CEMENT MASONS, ELECTRICIANS, PIPEFITTERS, PLUMBERS, PAINTERS, LABORERS, SEMI-SKILLED, LABORERS, UNSKILLED, and TOTAL.

TABLE B

Table with 4 columns: TOTAL EMPLOYEES (M, F) and MINORITY EMPLOYEES (M, F). Title: CURRENT EMPLOYEES TO BE ASSIGNED TO CONTRACT.

TABLE C

Table with 8 columns: EMPLOYEES IN TRAINING, TOTAL EMPLOYEES (M, F), BLACK (M, F), HISPANIC (M, F), and *OTHER MINOR. (M, F). Rows: APPRENTICES, ON THE JOB TRAINEES.

FOR DEPARTMENT USE ONLY

* Other minorities are defined as Asians (A) or Native Americans (N). Please specify race of each employee shown in Other Minorities column.

Note: See instructions on page 2

RETURN WITH BID

**Contract No. 76F72
Various Counties
Section DIST 8 GUARDRAIL 2013-1
Various Routes
District 8 Construction Funds**

PART II. WORKFORCE PROJECTION - continued

- B. Included in "Total Employees" under Table A is the total number of **new hires** that would be employed in the event the undersigned bidder is awarded this contract.

The undersigned bidder projects that: (number) _____ new hires would be recruited from the area in which the contract project is located; and/or (number) _____ new hires would be recruited from the area in which the bidder's principal office or base of operation is located.

- C. Included in "Total Employees" under Table A is a projection of numbers of persons to be employed directly by the undersigned bidder as well as a projection of numbers of persons to be employed by subcontractors.

The undersigned bidder estimates that (number) _____ persons will be directly employed by the prime contractor and that (number) _____ persons will be employed by subcontractors.

PART III. AFFIRMATIVE ACTION PLAN

- A. The undersigned bidder understands and agrees that in the event the foregoing minority and female employee utilization projection included under **PART II** is determined to be an underutilization of minority persons or women in any job category, and in the event that the undersigned bidder is awarded this contract, he/she will, prior to commencement of work, develop and submit a written Affirmative Action Plan including a specific timetable (geared to the completion stages of the contract) whereby deficiencies in minority and/or female employee utilization are corrected. Such Affirmative Action Plan will be subject to approval by the contracting agency and the **Department of Human Rights**.
- B. The undersigned bidder understands and agrees that the minority and female employee utilization projection submitted herein, and the goals and timetable included under an Affirmative Action Plan if required, are deemed to be part of the contract specifications.

Company _____ Telephone Number _____

Address _____

NOTICE REGARDING SIGNATURE

The Bidder's signature on the Proposal Signature Sheet will constitute the signing of this form. The following signature block needs to be completed if revisions are required.

Signature: _____ Title: _____ Date: _____

- Instructions: All tables must include subcontractor personnel in addition to prime contractor personnel.
- Table A - Include both the number of employees that would be hired to perform the contract work and the total number currently employed (Table B) that will be allocated to contract work, and include all apprentices and on-the-job trainees. The "Total Employees" column should include all employees including all minorities, apprentices and on-the-job trainees to be employed on the contract work.
- Table B - Include all employees currently employed that will be allocated to the contract work including any apprentices and on-the-job trainees currently employed.
- Table C - Indicate the racial breakdown of the total apprentices and on-the-job trainees shown in Table A.

RETURN WITH BID
Contract No. 76F72
Various Counties
Section DIST 8 GUARDRAIL 2013-1
Various Routes
District 8 Construction Funds

PROPOSAL SIGNATURE SHEET

The undersigned bidder hereby makes and submits this bid on the subject Proposal, thereby assuring the Department that all requirements of the Invitation for Bids and rules of the Department have been met, that there is no misunderstanding of the requirements of paragraph 3 of this Proposal, and that the contract will be executed in accordance with the rules of the Department if an award is made on this bid.

(IF AN INDIVIDUAL) Firm Name _____
Signature of Owner _____
Business Address _____

(IF A CO-PARTNERSHIP) Firm Name _____
By _____
Business Address _____
Name and Address of All Members of the Firm:

(IF A CORPORATION)
(IF A JOINT VENTURE, USE THIS SECTION FOR THE MANAGING PARTY AND THE SECOND PARTY SHOULD SIGN BELOW)

Corporate Name _____
By _____
Signature of Authorized Representative _____
Typed or printed name and title of Authorized Representative _____
Attest _____
Signature _____
Business Address _____

(IF A JOINT VENTURE)

Corporate Name _____
By _____
Signature of Authorized Representative _____
Typed or printed name and title of Authorized Representative _____
Attest _____
Signature _____
Business Address _____

If more than two parties are in the joint venture, please attach an additional signature sheet.



Return with Bid

Division of Highways
Proposal Bid Bond
(Effective November 1, 1992)

Item No.
Letting Date

KNOW ALL MEN BY THESE PRESENTS, That We

as PRINCIPAL, and

as SURETY, are held jointly, severally and firmly bound unto the STATE OF ILLINOIS in the penal sum of 5 percent of the total bid price, or for the amount specified in the bid proposal under "Proposal Guaranty" in effect on the date of the Invitation for Bids, whichever is the lesser sum, well and truly to be paid unto said STATE OF ILLINOIS, for the payment of which we bind ourselves, our heirs, executors, administrators, successors and assigns.

THE CONDITION OF THE FOREGOING OBLIGATION IS SUCH, that whereas, the PRINCIPAL has submitted a bid proposal to the STATE OF ILLINOIS, acting through the Department of Transportation, for the improvement designated by the Transportation Bulletin Item Number and Letting Date indicated above.

NOW, THEREFORE, if the Department shall accept the bid proposal of the PRINCIPAL; and if the PRINCIPAL shall, within the time and as specified in the bidding and contract documents, submit a DBE Utilization Plan that is accepted and approved by the Department; and if, after award by the Department, the PRINCIPAL shall enter into a contract in accordance with the terms of the bidding and contract documents including evidence of the required insurance coverages and providing such bond as specified with good and sufficient surety for the faithful performance of such contract and for the prompt payment of labor and material furnished in the prosecution thereof; or if, in the event of the failure of the PRINCIPAL to make the required DBE submission or to enter into such contract and to give the specified bond, the PRINCIPAL pays to the Department the difference not to exceed the penalty hereof between the amount specified in the bid proposal and such larger amount for which the Department may contract with another party to perform the work covered by said bid proposal, then this obligation shall be null and void, otherwise, it shall remain in full force and effect.

IN THE EVENT the Department determines the PRINCIPAL has failed to comply with any requirement as set forth in the preceding paragraph, then Surety shall pay the penal sum to the Department within fifteen (15) days of written demand therefor. If Surety does not make full payment within such period of time, the Department may bring an action to collect the amount owed. Surety is liable to the Department for all its expenses, including attorney's fees, incurred in any litigation in which it prevails either in whole or in part.

In TESTIMONY WHEREOF, the said PRINCIPAL and the said SURETY have caused this instrument to be signed by their respective officers this day of A.D.,

PRINCIPAL SURETY
(Company Name) (Company Name)
By (Signature & Title) By: (Signature of Attorney-in-Fact)

Notary Certification for Principal and Surety

STATE OF ILLINOIS,
County of
I, a Notary Public in and for said County, do hereby certify that
and
(Insert names of individuals signing on behalf of PRINCIPAL & SURETY)

who are each personally known to me to be the same persons whose names are subscribed to the foregoing instrument on behalf of PRINCIPAL and SURETY, appeared before me this day in person and acknowledged respectively, that they signed and delivered said instrument as their free and voluntary act for the uses and purposes therein set forth.

Given under my hand and notarial seal this day of A.D.
My commission expires
Notary Public

In lieu of completing the above section of the Proposal Bid Form, the Principal may file an Electronic Bid Bond. By signing the proposal and marking the check box next to the Signature and Title line below, the Principal is ensuring the identified electronic bid bond has been executed and the Principal and Surety are firmly bound unto the State of Illinois under the conditions of the bid bond as shown above.

Electronic Bid Bond ID# Company / Bidder Name Signature and Title

(1) Policy

It is public policy that disadvantageded businesses as defined in 49 CFR Part 26 and the Special Provision shall have the maximum opportunity to participate in the performance of contracts financed in whole or in part with Federal or State funds. Consequently the requirements of 49 CFR Part 26 apply to this contract.

(2) Obligation

The contractor agrees to ensure that disadvantageded businesses as defined in 49 CFR Part 26 and the Special Provision have the maximum opportunity to participate in the performance of contracts or subcontracts financed in whole or in part with Federal or State funds. The contractor shall take all necessary and reasonable steps in accordance with 49 CFR Part 26 and the Special Provision to ensure that said businesses have the maximum opportunity to compete for and perform under this contract. The contractor shall not discriminate on the basis of race, color, national origin or sex in the award and performance of contracts.

(3) Project and Bid Identification

Complete the following information concerning the project and bid:

| | |
|------------------------|--|
| Route _____ | Total Bid _____ |
| Section _____ | Contract DBE Goal _____ |
| Project _____ | (Percent) (Dollar Amount) |
| County _____ | |
| Letting Date _____ | |
| Contract No. _____ | |
| Letting Item No. _____ | |

(4) Assurance

I, acting in my capacity as an officer of the undersigned bidder (or bidders if a joint venture), hereby assure the Department that on this project my company : (check one)

Meets or exceeds contract award goals and has provided documented participation as follows:
Disadvantaged Business Participation _____ percent

Attached are the signed participation statements, forms SBE 2025, required by the Special Provision evidencing availability and use of each business participating in this plan and assuring that each business will perform a commercially useful function in the work of the contract.

Failed to meet contract award goals and has included good faith effort documentation to meet the goals and that my company has provided participation as follows:

Disadvantaged Business Participation _____ percent

The contract goals should be accordingly modified or waived. Attached is all information required by the Special Provision in support of this request including good faith effort. Also attached are the signed participation statements, forms SBE 2025, required by the Special Provision evidencing availability and use of each business participating in this plan and assuring that each business will perform a commercially useful function in the work of the contract.

Company

By _____

Title _____

Date _____

The "as read" Low Bidder is required to comply with the Special Provision.

Submit only one utilization plan for each project. The utilization plan shall be submitted in accordance with the special provision.

Bureau of Small Business Enterprises **Local Let Projects**
2300 South Dirksen Parkway Submit forms to the
Springfield, Illinois 62764 Local Agency



**Illinois Department
of Transportation**

Subcontractor Registration _____

Participation Statement

(1) Instructions

This form must be completed for each disadvantaged business participating in the Utilization Plan. This form shall be submitted in accordance with the special provision and will be attached to the Utilization Plan form. If additional space is needed complete an additional form for the firm.

(2) Work

| Pay Item No. | Description | Quantity | Unit Price | Total |
|--------------|-------------|----------|------------|-------|
| | | | | |
| | | | | |
| | | | | |
| | | | | |
| | | | | |
| | | | | |
| | | | | |
| Total | | | | |

(3) Partial Payment Items

For any of the above items which are partial pay items, specifically describe the work and subcontract dollar amount:

(4) Commitment

The undersigned certify that the information included herein is true and correct, and that the DBE firm listed below has agreed to perform a commercially useful function in the work of the contract item(s) listed above and to execute a contract with the prime contractor. The undersigned further understand that no changes to this statement may be made without prior approval from the Department's Bureau of Small Business Enterprises and that complete and accurate information regarding actual work performed on this project and the payment therefore must be provided to the Department.

Signature for Prime Contractor

Signature for DBE Firm

Title _____

Title _____

Date _____

Date _____

Contact _____

Contact _____

Phone _____

Phone _____

Firm Name _____

Firm Name _____

Address _____

Address _____

City/State/Zip _____

City/State/Zip _____

E _____

WC _____

The Department of Transportation is requesting disclosure of information that is necessary to accomplish the statutory purpose as outlined under the state and federal law. Disclosure of this information is **REQUIRED**. Failure to provide any information will result in the contract not being awarded. This form has been approved by the State Forms Management Center.

PROPOSAL ENVELOPE



PROPOSALS

for construction work advertised for bids by the
Illinois Department of Transportation

| Item No. | Item No. | Item No. |
|----------|----------|----------|
| | | |
| | | |
| | | |
| | | |

Submitted By:

| |
|-----------|
| Name: |
| Address: |
| |
| |
| Phone No. |

Bidders should use an IDOT proposal envelope or affix this form to the front of a 10" x 13" envelope for the submittal of bids. If proposals are mailed, they should be enclosed in a second or outer envelope addressed to:

Engineer of Design and Environment - Room 326
Illinois Department of Transportation
2300 South Dirksen Parkway
Springfield, Illinois 62764

NOTICE

Individual bids, including Bid Bond and/or supplemental information if required, should be securely stapled.

CONTRACTOR OFFICE COPY OF CONTRACT SPECIFICATIONS

NOTICE

None of the following material needs to be returned with the bid package unless the special provisions require documentation and/or other information to be submitted.

Contract No. 76F72
Various Counties
Section DIST 8 GUARDRAIL 2013-1
Various Routes
District 8 Construction Funds



Illinois Department of Transportation

SUBCONTRACTOR DOCUMENTATION

Public Acts 96-0795 and 96-0920, enacted substantial changes to the provisions of the Illinois Procurement Code (30 ILCS 500). Among the changes are provisions affecting subcontractors. The Contractor awarded this contract will be required as a material condition of the contract to implement and enforce the contract requirements applicable to subcontractors approved in accordance with article 108.01 of the Standard Specifications for Road and Bridge Construction.

If the Contractor seeks approval of subcontractors to perform a portion of the work, and approval is granted by the Department, the Contractor shall provide a copy of the subcontract to the Chief Procurement Officer within 20 calendar days after execution of the subcontract.

The subcontract shall contain the certifications required to be made by subcontractors pursuant to Article 50 of the Illinois Procurement Code. This Notice to Bidders includes a document incorporating all required subcontractor certifications and disclosures for use by the Contractor in compliance with this mandate. The document is entitled State Required Ethical Standards Governing Subcontractors.

RETURN WITH SUBCONTRACT

STATE ETHICAL STANDARDS GOVERNING SUBCONTRACTORS

Article 50 of the Illinois Procurement Code establishes the duty of all State chief procurement officers, State purchasing officers, and their designees to maximize the value of the expenditure of public moneys in procuring goods, services, and contracts for the State of Illinois and to act in a manner that maintains the integrity and public trust of State government. In discharging this duty, they are charged by law to use all available information, reasonable efforts, and reasonable actions to protect, safeguard, and maintain the procurement process of the State of Illinois.

The certifications hereinafter made by the subcontractor are each a material representation of fact upon which reliance is placed should the Department approve the subcontractor. The chief procurement officer may terminate or void the subcontract approval if it is later determined that the bidder or subcontractor rendered a false or erroneous certification.

Section 50-2 of the Illinois Procurement Code provides that every person that has entered into a multi-year contract and every subcontractor with a multi-year subcontract shall certify, by July 1 of each fiscal year covered by the contract after the initial fiscal year, to the responsible chief procurement officer whether it continues to satisfy the requirements of Article 50 pertaining to the eligibility for a contract award. If a contractor or subcontractor is not able to truthfully certify that it continues to meet all requirements, it shall provide with its certification a detailed explanation of the circumstances leading to the change in certification status. A contractor or subcontractor that makes a false statement material to any given certification required under Article 50 is, in addition to any other penalties or consequences prescribed by law, subject to liability under the Whistleblower Reward and Protection Act for submission of a false claim.

A. Bribery

1. The Illinois Procurement Code provides:

Section 50-5. Bribery.

(a) Prohibition. No person or business shall be awarded a contract or subcontract under this Code who:

(1) has been convicted under the laws of Illinois or any other state of bribery or attempting to bribe an officer or employee of the State of Illinois or any other state in that officer's or employee's official capacity; or

(2) has made an admission of guilt of that conduct that is a matter of record but has not been prosecuted for that conduct.

(b) Businesses. No business shall be barred from contracting with any unit of State or local government, or subcontracting under such a contract, as a result of a conviction under this Section of any employee or agent of the business if the employee or agent is no longer employed by the business and:

(1) the business has been finally adjudicated not guilty; or

(2) the business demonstrates to the governmental entity with which it seeks to contract, or which is signatory to the contract to which the subcontract relates, and that entity finds that the commission of the offense was not authorized, requested, commanded, or performed by a director, officer, or high managerial agent on behalf of the business as provided in paragraph (2) of subsection (a) of Section 5-4 of the Criminal Code of 1961.

(c) Conduct on behalf of business. For purposes of this Section, when an official, agent, or employee of a business committed the bribery or attempted bribery on behalf of the business and in accordance with the direction or authorization of a responsible official of the business, the business shall be chargeable with the conduct.

(d) Certification. Every bid submitted to and contract executed by the State, and every subcontract subject to Section 20-120 of the Procurement Code shall contain a certification by the contractor or the subcontractor, respectively, that the contractor or subcontractor is not barred from being awarded a contract or subcontract under this Section and acknowledges that the chief procurement officer may declare the related contract void if any certifications required by this Section are false. A contractor who makes a false statement, material to the certification, commits a Class 3 felony.

2. The contractor or subcontractor certifies that it is not barred from being awarded a contract under Section 50.5.

B. Felons

1. The Illinois Procurement Code provides:

Section 50-10. Felons. Unless otherwise provided, no person or business convicted of a felony shall do business with the State of Illinois or any State agency, or enter into a subcontract, from the date of conviction until 5 years after the date of completion of the sentence for that felony, unless no person held responsible by a prosecutorial office for the facts upon which the conviction was based continues to have any involvement with the business.

2. Certification. Every bid submitted to and contract executed by the State and every subcontract subject to Section 20-120 of the Procurement Code shall contain a certification by the bidder or contractor or subcontractor, respectively, that the bidder, contractor, or subcontractor is not barred from being awarded a contract or subcontract under this Section and acknowledges that the chief procurement officer may declare the related contract void if any of the certifications required by this Section are false.

RETURN WITH SUBCONTRACT

C. Debt Delinquency

1. The Illinois Procurement Code provides:

Section 50-11 and 50-12. Debt Delinquency.

The contractor or bidder or subcontractor, respectively, certifies that it, or any affiliate, is not barred from being awarded a contract or subcontract under the Procurement Code. Section 50-11 prohibits a person from entering into a contract with a State agency, or entering into a subcontract, if it knows or should know that it, or any affiliate, is delinquent in the payment of any debt to the State as defined by the Debt Collection Board. Section 50-12 prohibits a person from entering into a contract with a State agency, or entering into a subcontract, if it, or any affiliate, has failed to collect and remit Illinois Use Tax on all sales of tangible personal property into the State of Illinois in accordance with the provisions of the Illinois Use Tax Act. The bidder or contractor or subcontractor, respectively, further acknowledges that the chief procurement officer may declare the related contract void if this certification is false or if the bidder, contractor, or subcontractor, or any affiliate, is determined to be delinquent in the payment of any debt to the State during the term of the contract.

D. Prohibited Bidders, Contractors and Subcontractors

1. The Illinois Procurement Code provides:

Section 50-10.5 and 50-60(c). Prohibited bidders, contractors and subcontractors.

The bidder or contractor or subcontractor, respectively, certifies in accordance with 30 ILCS 500/50-10.5 that no officer, director, partner or other managerial agent of the contracting business has been convicted of a felony under the Sarbanes-Oxley Act of 2002 or a Class 3 or Class 2 felony under the Illinois Securities Law of 1953 or if in violation of Subsection (c) for a period of five years from the date of conviction.. Every bid submitted to and contract executed by the State and every subcontract subject to Section 20-120 of the Procurement Code shall contain a certification by the bidder, contractor, or subcontractor, respectively, that the bidder, contractor, or subcontractor is not barred from being awarded a contract or subcontract under this Section and acknowledges that the chief procurement officer shall declare the related contract void if any of the certifications completed pursuant to this Section are false.

E. Section 42 of the Environmental Protection Act

The bidder or contractor or subcontractor, respectively, certifies in accordance with 30 ILCS 500/50-12 that the bidder, contractor, or subcontractor, is not barred from being awarded a contract or entering into a subcontract under this Section which prohibits the bidding on or entering into contracts with the State of Illinois or a State agency, or entering into any subcontract, that is subject to the Procurement Code by a person or business found by a court or the Pollution Control Board to have committed a willful or knowing violation of Section 42 of the Environmental Protection Act for a period of five years from the date of the order. The bidder or contractor or subcontractor, respectively, acknowledges that the chief procurement officer may declare the contract void if this certification is false.

The undersigned, on behalf of the subcontracting company, has read and understands the above certifications and makes the certifications as required by law.

| | | |
|--------------------------------|--|-------|
| _____ | | |
| Name of Subcontracting Company | | |
| _____ | | _____ |
| Authorized Officer | | Date |

RETURN WITH SUBCONTRACT
SUBCONTRACTOR DISCLOSURES

I. DISCLOSURES

- A. The disclosures hereinafter made by the subcontractor are each a material representation of fact upon which reliance is placed. The subcontractor further certifies that the Department has received the disclosure forms for each subcontract.

The chief procurement officer may void the bid, contract, or subcontract, respectively, if it is later determined that the bidder or subcontractor rendered a false or erroneous disclosure. A contractor or subcontractor may be suspended or debarred for violations of the Procurement Code. Furthermore, the chief procurement officer may void the contract or subcontract.

B. Financial Interests and Conflicts of Interest

1. Section 50-35 of the Illinois Procurement Code provides that all subcontracts with a total value of \$25,000 or more from subcontractors identified in Section 20-120 of the Illinois Procurement Code, shall be accompanied by disclosure of the financial interests of the subcontractor. This disclosed information for the subcontractor, will be maintained as public information subject to release by request pursuant to the Freedom of Information Act, filed with the Procurement Policy Board, and shall be incorporated as a material term of the Prime Contractor's contract. Furthermore, pursuant to this Section, the Procurement Policy Board may recommend to allow or void a contract or subcontract based on a potential conflict of interest.

The financial interests to be disclosed shall include ownership or distributive income share that is in excess of 5%, or an amount greater than 60% of the annual salary of the Governor, of the subcontracting entity or its parent entity, whichever is less, unless the subcontractor is a publicly traded entity subject to Federal 10K reporting, in which case it may submit its 10K disclosure in place of the prescribed disclosure. If a subcontractor is a privately held entity that is exempt from Federal 10K reporting, but has more than 200 shareholders, it may submit the information that Federal 10K companies are required to report, and list the names of any person or entity holding any ownership share that is in excess of 5%. The disclosure shall include the names, addresses, and dollar or proportionate share of ownership of each person making the disclosure, their instrument of ownership or beneficial relationship, and notice of any potential conflict of interest resulting from the current ownership or beneficial interest of each person making the disclosure having any of the relationships identified in Section 50-35 and on the disclosure form.

The current annual salary of the Governor is \$177,412.00.

In addition, all disclosures shall indicate any other current or pending contracts, subcontracts, proposals, leases, or other ongoing procurement relationships the subcontracting entity has with any other unit of state government and shall clearly identify the unit and the contract, subcontract, proposal, lease, or other relationship.

2. Disclosure Forms. Disclosure Form A is attached for use concerning the individuals meeting the above ownership or distributive share requirements. A separate Disclosure Form A must be submitted with the bid for each individual meeting the above requirements. In addition, a second form (Disclosure Form B) provides for the disclosure of current or pending procurement relationships with other (non-IDOT) state agencies and a total ownership certification. **The forms must be included with each bid.**

C. Disclosure Form Instructions

Form A Instructions for Financial Information & Potential Conflicts of Interest

If the subcontractor is a publicly traded entity subject to Federal 10K reporting, the 10K Report may be submitted to meet the requirements of Form A. If a subcontractor is a privately held entity that is exempt from Federal 10K reporting, but has more than 200 shareholders, it may submit the information that Federal 10K companies are required to report, and list the names of any person or entity holding any ownership share that is in excess of 5%. If a subcontractor is not subject to Federal 10K reporting, the subcontractor must determine if any individuals are required by law to complete a financial disclosure form. To do this, the subcontractor should answer each of the following questions. A "YES" answer indicates Form A must be completed. If the answer to each of the following questions is "NO", then the NOT APPLICABLE STATEMENT on the second page of Form A must be signed and dated by a person that is authorized to execute contracts for the subcontracting company. Note: These questions are for assistance only and are not required to be completed.

1. Does anyone in your organization have a direct or beneficial ownership share of greater than 5% of the bidding entity or parent entity? YES ___ NO ___
2. Does anyone in your organization have a direct or beneficial ownership share of less than 5%, but which has a value greater than 60% of the annual salary of the Governor? YES ___ NO ___
3. Does anyone in your organization receive more than 60% of the annual salary of the Governor of the subcontracting entity's or parent entity's distributive income? YES ___ NO ___.

(Note: Distributive income is, for these purposes, any type of distribution of profits. An annual salary is not distributive income.)

4. Does anyone in your organization receive greater than 5% of the subcontracting entity's or parent entity's total distributive income, but which is less than 60% of the annual salary of the Governor? YES ___ NO ___

(Note: Only one set of forms needs to be completed per person per subcontract even if a specific individual would require a yes answer to more than one question.)

A "YES" answer to any of these questions requires the completion of Form A. The subcontractor must determine each individual in the subcontracting entity or the subcontracting entity's parent company that would cause the questions to be answered "Yes". Each form must be signed and dated by a person that is authorized to execute contracts for your organization. **Photocopied or stamped signatures are not acceptable.** The person signing can be, but does not have to be, the person for which the form is being completed. The subcontractor is responsible for the accuracy of any information provided.

If the answer to each of the above questions is "NO", then the NOT APPLICABLE STATEMENT on page 2 of Form A must be signed and dated by a person that is authorized to execute contracts for your company.

RETURN WITH SUBCONTRACT

Form B: Instructions for Identifying Other Contracts & Procurement Related Information

Disclosure Form B must be completed for each subcontract submitted by the subcontracting entity. *Note: Checking the NOT APPLICABLE STATEMENT on Form A does not allow the subcontractor to ignore Form B. Form B must be completed, checked, and dated or the subcontract will not be approved.*

The Subcontractor shall identify, by checking Yes or No on Form B, whether it has any pending contracts, subcontracts, leases, bids, proposals, or other ongoing procurement relationship with any other (non-IDOT) State of Illinois agency. If "No" is checked, the subcontractor only needs to complete the check box on the bottom of Form B. If "Yes" is checked, the subcontractor must list all non-IDOT State of Illinois agency pending contracts, subcontracts, leases, bids, proposals, and other ongoing procurement relationships. These items may be listed on Form B or on an attached sheet(s). Contracts with cities, counties, villages, etc. are not considered State of Illinois agency contracts and are not to be included. Contracts or subcontracts with other State of Illinois agencies such as the Department of Natural Resources or the Capital Development Board must be included.

ILLINOIS DEPARTMENT OF TRANSPORTATION

Form A Subcontractor: Financial Information & Potential Conflicts of Interest Disclosure

Form with fields: Subcontractor Name, Legal Address, City, State, Zip, Telephone Number, Email Address, Fax Number (if available)

Disclosure of the information contained in this Form is required by the Section 50-35 of the Illinois Procurement Code (30 ILCS 500). Subcontractors desiring to enter into a subcontract of a State of Illinois contract must disclose the financial information and potential conflict of interest information as specified in this Disclosure Form. This information shall become part of the publicly available contract file. This Form A must be completed for subcontracts with a total value of \$25,000 or more, from subcontractors identified in Section 20-120 of the Illinois Procurement Code, and for all open-ended contracts. A publicly traded company may submit a 10K disclosure (or equivalent if applicable) in satisfaction of the requirements set forth in Form A. See Disclosure Form Instructions.

The current annual salary of the Governor is \$177,412.00.

DISCLOSURE OF FINANCIAL INFORMATION

1. Disclosure of Financial Information. The individual named below has an interest in the SUBCONTRACTOR (or its parent) in terms of ownership or distributive income share in excess of 5%, or an interest which has a value of more than 60% of the annual salary of the Governor. (Make copies of this form as necessary and attach a separate Disclosure Form A for each individual meeting these requirements)

FOR INDIVIDUAL (type or print information) NAME: ADDRESS Type of ownership/distributable income share: stock sole proprietorship Partnership other: (explain on separate sheet): % or \$ value of ownership/distributable income share:

2. Disclosure of Potential Conflicts of Interest. Check "Yes" or "No" to indicate which, if any, of the following potential conflict of interest relationships apply. If the answer to any question is "Yes", please attach additional pages and describe.

(a) State employment, currently or in the previous 3 years, including contractual employment of services. Yes ___ No ___

If your answer is yes, please answer each of the following questions.

- 1. Are you currently an officer or employee of either the Capitol Development Board or the Illinois State Toll Highway Authority? Yes ___ No ___
2. Are you currently appointed to or employed by any agency of the State of Illinois? If you are currently appointed to or employed by any agency of the State of Illinois, and your annual salary exceeds 60% of the annual salary of the Governor, provide the name the State agency for which you are employed and your annual salary.

RETURN WITH SUBCONTRACT

3. If you are currently appointed to or employed by any agency of the State of Illinois, and your annual salary exceeds 60% of the annual salary of the Governor, are you entitled to receive (i) more than 7 1/2% of the total distributable income of your firm, partnership, association or corporation, or (ii) an amount in excess of 100% of the annual salary of the Governor?
Yes ___ No ___

4. If you are currently appointed to or employed by any agency of the State of Illinois, and your annual salary exceeds 60% of the annual salary of the Governor, are you and your spouse or minor children entitled to receive (i) more than 15 % in the aggregate of the total distributable income of your firm, partnership, association or corporation, or (ii) an amount in excess of two times the salary of the Governor?
Yes ___ No ___

(b) State employment of spouse, father, mother, son, or daughter, including contractual employment services in the previous 2 years.

Yes ___ No ___

If your answer is yes, please answer each of the following questions.

1. Is your spouse or any minor children currently an officer or employee of the Capitol Development Board or the Illinois Toll Highway Authority?
Yes ___ No ___

2. Is your spouse or any minor children currently appointed to or employed by any agency of the State of Illinois? If your spouse or minor children is/are currently appointed to or employed by any agency of the State of Illinois, and his/her annual salary exceeds 60% of the annual salary of the Governor, provide the name of your spouse and/or minor children, the name of the State agency for which he/she is employed and his/her annual salary. _____

3. If your spouse or any minor children is/are currently appointed to or employed by any agency of the State of Illinois, and his/her annual salary exceeds 60% of the annual salary of the Governor, as of 7/1/07) are you entitled to receive (i) more then 7 1/2% of the total distributable income of your firm, partnership, association or corporation, or (ii) an amount in excess of 100% of the annual salary of the Governor?
Yes ___ No ___

4. If your spouse or any minor children are currently appointed to or employed by any agency of the State of Illinois, and his/her annual salary exceeds 60% of the annual salary of the Governor, are you and your spouse or minor children entitled to receive (i) more than 15 % in the aggregate of the total distributable income of your firm, partnership, association or corporation, or (ii) an amount in excess of two times the annual salary of the Governor?
Yes ___ No ___

(c) Elective status; the holding of elective office of the State of Illinois, the government of the United States, any unit of local government authorized by the Constitution of the State of Illinois or the statutes of the State of Illinois currently or in the previous 3 years.
Yes ___ No ___

(d) Relationship to anyone holding elective office currently or in the previous 2 years; spouse, father, mother, son, or daughter.
Yes ___ No ___

(e) Appointive office; the holding of any appointive government office of the State of Illinois, the United States of America, or any unit of local government authorized by the Constitution of the State of Illinois or the statutes of the State of Illinois, which office entitles the holder to compensation in excess of the expenses incurred in the discharge of that office currently or in the previous 3 years.
Yes ___ No ___

(f) Relationship to anyone holding appointive office currently or in the previous 2 years; spouse, father, mother, son, or daughter.
Yes ___ No ___

(g) Employment, currently or in the previous 3 years, as or by any registered lobbyist of the State government.
Yes ___ No ___

RETURN WITH SUBCONTRACT

(h) Relationship to anyone who is or was a registered lobbyist in the previous 2 years; spouse, father, mother, son, or daughter. Yes ___ No ___

(i) Compensated employment, currently or in the previous 3 years, by any registered election or reelection committee registered with the Secretary of State or any county clerk of the State of Illinois, or any political action committee registered with either the Secretary of State or the Federal Board of Elections. Yes ___ No ___

(j) Relationship to anyone; spouse, father, mother, son, or daughter; who was a compensated employee in the last 2 years by any registered election or re-election committee registered with the Secretary of State or any county clerk of the State of Illinois, or any political action committee registered with either the Secretary of State or the Federal Board of Elections. Yes ___ No ___

3 Communication Disclosure.

Disclose the name and address of each lobbyist and other agent of the bidder or offeror who is not identified in Section 2 of this form, who is has communicated, is communicating, or may communicate with any State officer or employee concerning the bid or offer. This disclosure is a continuing obligation and must be promptly supplemented for accuracy throughout the process and throughout the term of the contract. If no person is identified, enter "None" on the line below:

Name and address of person(s): _____

RETURN WITH SUBCONTRACT

4. Debarment Disclosure. For each of the persons identified under Sections 2 and 3 of this form, disclose whether any of the following has occurred within the previous 10 years: debarment from contracting with any governmental entity; professional licensure discipline; bankruptcies; adverse civil judgments and administrative findings; and criminal felony convictions. This disclosure is a continuing obligation and must be promptly supplemented for accuracy throughout the procurement process and term of the contract. If no person is identified, enter "None" on the line below:

Name of person(s): _____

Nature of disclosure: _____

APPLICABLE STATEMENT

This Disclosure Form A is submitted on behalf of the INDIVIDUAL named on previous page. Under penalty of perjury, I certify the contents of this disclosure to be true and accurate to the best of my knowledge.

Completed by: _____ Date _____
Signature of Individual or Authorized Officer

NOT APPLICABLE STATEMENT

Under penalty of perjury, I have determined that no individuals associated with this organization meet the criteria that would require the completion of this Form A.

This Disclosure Form A is submitted on behalf of the SUBCONTRACTOR listed on the previous page.

_____ Date _____
Signature of Authorized Officer

RETURN WITH SUBCONTRACT

ILLINOIS DEPARTMENT OF TRANSPORTATION

Form B
Subcontractor: Other Contracts & Financial Related Information Disclosure

Form with fields: Subcontractor Name, Legal Address, City, State, Zip, Telephone Number, Email Address, Fax Number (if available)

Disclosure of the information contained in this Form is required by the Section 50-35 of the Illinois Procurement Act (30 ILCS 500). This information shall become part of the publicly available contract file. This Form B must be completed for subcontracts with a total value of \$25,000 or more, from subcontractors identified in Section 20-120 of the Illinois Procurement Code, and for all open-ended contracts.

DISCLOSURE OF OTHER CONTRACTS, SUBCONTRACTS, AND PROCUREMENT RELATED INFORMATION

1. Identifying Other Contracts & Procurement Related Information. The SUBCONTRACTOR shall identify whether it has any pending contracts, subcontracts, including leases, bids, proposals, or other ongoing procurement relationship with any other State of Illinois agency: Yes ___ No ___

If "No" is checked, the subcontractor only needs to complete the signature box on the bottom of this page.

2. If "Yes" is checked. Identify each such relationship by showing State of Illinois agency name and other descriptive information such as bid or project number (attach additional pages as necessary). SEE DISCLOSURE FORM INSTRUCTIONS:

THE FOLLOWING STATEMENT MUST BE CHECKED

Signature box with fields: Signature of Authorized Representative, Date

OWNERSHIP CERTIFICATION

Please certify that the following statement is true if the individuals for all submitted Form A disclosures do not total 100% of ownership

Any remaining ownership interest is held by individuals receiving less than \$106,447.20 of the bidding entity's or parent entity's distributive income or holding less than a 5% ownership interest.

Yes No N/A (Form A disclosure(s) established 100% ownership)



- 1. TIME AND PLACE OF OPENING BIDS.** Sealed proposals for the improvement described herein will be received by the Department of Transportation at the Harry R. Hanley Building, 2300 South Dirksen Parkway, in Springfield, Illinois until 10:00 o'clock a.m., June 15, 2012. All bids will be gathered, sorted, publicly opened and read in the auditorium at the Department of Transportation's Harry R. Hanley Building shortly after the 10:00 a.m. cut off time.
- 2. DESCRIPTION OF WORK.** The proposed improvement is identified and advertised for bids in the Invitation for Bids as:

**Contract No. 76F72
Various Counties
Section DIST 8 GUARDRAIL 2013-1
Various Routes
District 8 Construction Funds**

This project consists of guardrail and cable rail repairs at various locations throughout District 8.

- 3. INSTRUCTIONS TO BIDDERS.** (a) This Notice, the invitation for bids, proposal and letter of award shall, together with all other documents in accordance with Article 101.09 of the Standard Specifications for Road and Bridge Construction, become part of the contract. Bidders are cautioned to read and examine carefully all documents, to make all required inspections, and to inquire or seek explanation of the same prior to submission of a bid.

(b) State law, and, if the work is to be paid wholly or in part with Federal-aid funds, Federal law requires the bidder to make various certifications as a part of the proposal and contract. By execution and submission of the proposal, the bidder makes the certification contained therein. A false or fraudulent certification shall, in addition to all other remedies provided by law, be a breach of contract and may result in termination of the contract.
- 4. AWARD CRITERIA AND REJECTION OF BIDS.** This contract will be awarded to the lowest responsive and responsible bidder considering conformity with the terms and conditions established by the Department in the rules, Invitation for Bids and contract documents. The issuance of plans and proposal forms for bidding based upon a prequalification rating shall not be the sole determinant of responsibility. The Department reserves the right to determine responsibility at the time of award, to reject any or all proposals, to readvertise the proposed improvement, and to waive technicalities.

By Order of the
Illinois Department of Transportation

Ann L. Schneider,
Secretary

INDEX
FOR
SUPPLEMENTAL SPECIFICATIONS
AND RECURRING SPECIAL PROVISIONS

Adopted January 1, 2012

This index contains a listing of SUPPLEMENTAL SPECIFICATIONS and frequently used RECURRING SPECIAL PROVISIONS.

SUPPLEMENTAL SPECIFICATIONS

Std. Spec. Sec.

Page No.

No Supplemental Specifications this year.

RECURRING SPECIAL PROVISIONS

The following RECURRING SPECIAL PROVISIONS indicated by an "X" are applicable to this contract and are included by reference:

| <u>CHECK SHEET #</u> | <u>PAGE NO.</u> |
|----------------------|-----------------|
| 1 | 1 |
| 2 | 4 |
| 3 X | 5 |
| 4 X | 15 |
| 5 X | 20 |
| 6 | 25 |
| 7 | 26 |
| 8 | 27 |
| 9 | 28 |
| 10 | 31 |
| 11 | 34 |
| 12 | 36 |
| 13 | 40 |
| 14 | 42 |
| 15 | 43 |
| 16 | 45 |
| 17 | 46 |
| 18 | 48 |
| 19 | 49 |
| 20 X | 50 |
| 21 | 54 |
| 22 | 56 |
| 23 | 58 |
| 24 X | 60 |
| 25 | 61 |
| 26 | 62 |
| 27 | 63 |
| 28 | 64 |
| 29 | 65 |
| 30 | 68 |
| 31 | 76 |

TABLE OF CONTENTS

LOCATION OF PROJECT 1
DESCRIPTION OF PROJECT 1
MONTHLY LABOR SUMMARY AND ACTIVITY REPORTING SYSTEM..... 1
TRAFFIC CONTROL PLAN 4
CONSTRUCTION AND MAINTENANCE SIGN SUPPORTS 4
STATUS OF UTILITIES TO BE ADJUSTED..... 5
TERM OF CONTRACT 5
PROSECUTION OF THE WORK..... 5
CONTROL OF WORK..... 5
COMPLETION DATE 5
FAILURE TO COMPLETE OR REPAIR – LIQUIDATED DAMAGES 6
WORK DURING PEAK HOURS 6
PENALTY DURING PEAK HOURS 7
WORK ZONE LANE CLOSURE REQUEST 7
INTERPRETATION OF QUANTITIES AND PAYMENT 10
WORK ORDER 10
CLASS OF WORK 12
COMPLETION TIME FOR WORK ORDERS 12
CALENDAR DAYS 12
CONTRACTOR’S RESPONSIBILITY FOR DAMAGE TO EXISTING STRUCTURES 12
THE CONTRACTOR’S LIABILITY 13
PROTECTION FOR DAMAGED LOCATIONS 13
REALIGNING POSTS 13
REMOVAL OR REPAIR OF GUARDRAIL 14
FINAL CLEAN UP 14
CONTRACTOR CONTACTS 15
CLEARING 15
GUARDRAIL BLOCKS 15
RAIL ELEMENT PLATES 15
TRAFFIC BARRIER TERMINAL, TYPE 1, SPECIAL 16
REPAIR TRAFFIC BARRIER TERMINAL TYPE 1 SPECIAL – POST 17
REPAIR TRAFFIC BARRIER TERMINAL TYPE 1 SPECIAL – RAIL ELEMENT PLATE 17
TRAFFIC BARRIER TERMINAL, TYPE 5 & 6 17
SINGLE END SECTION 18
TRAFFIC BARRIER TERMINAL, TYPE 2 18
STEEL POSTS 19

REMOVAL AND REINSTALLATION OF EXISTING IMPACT ATTENUATORS 19

REPAIR TRAFFIC BARRIER TERMINAL TYPE 1 SPECIAL (TANGENT) 19

EXTRUDER HEAD 20

REPAIR TRAFFIC BARRIER TERMINAL TYPE 1 SPECIAL (FLARED) AND TYPE 3A..... 20

REPAIR TRAFFIC BARRIER TERMINAL TYPE 2, 5 AND 6 21

CABLE GUARDPOSTS 21

HIGH TENSION CABLE ROAD GUARDPOSTS 22

STEEL POSTS, ATTACHED TO STRUCTURE 22

STEEL POSTS (SPECIAL) 22

HIGH TENSION CABLE POST REPAIR..... 23

REPAIR HIGH TENSION CABLE 23

MEDIAN CABLE 23

LOCATING UNDERGROUND CABLE, SPECIAL 23

REPLACE HIGH TENSION CABLE GUARDPOST FOUNDATION**ERROR! BOOKMARK NOT DEFINED.**

AGREEMENT TO PLAN QUANTITY (BDE) 24

AUTOMATED FLAGGER ASSISTANCE DEVICES (BDE)..... 24

CONSTRUCTION AIR QUALITY – DIESEL RETROFIT (BDE)..... 25

CONSTRUCTION AIR QUALITY - DIESEL VEHICLE EMISSIONS CONTROL (BDE)..... 27

CONSTRUCTION AIR QUALITY - IDLING RESTRICTIONS (BDE)..... 28

DISADVANTAGED BUSINESS ENTERPRISE PARTICIPATION (BDE) 29

ERRATA FOR THE 2012 STANDARD SPECIFICATIONS (BDE)..... 37

FLAGGER AT SIDE ROADS AND ENTRANCES (BDE) 37

HIGH TENSION CABLE MEDIAN BARRIER (BDE) 37

IMPACT ATTENUATORS (BDE) 39

PAYMENTS TO SUBCONTRACTORS (BDE)..... 40

PAYROLLS AND PAYROLL RECORDS (BDE)..... 41

SUBCONTRACTOR MOBILIZATION PAYMENTS (BDE) 42

TRAFFIC CONTROL DEFICIENCY DEDUCTION (BDE) 43

UTILITY COORDINATION AND CONFLICTS (BDE) 43

STEEL COST ADJUSTMENT (BDE) (RETURN FORM WITH BID) 48

STATE OF ILLINOIS **SPECIAL PROVISIONS**

The following Special Provisions supplement the "Standard Specifications for Road and Bridge Construction," adopted January 1, 2012, the latest edition of the "Manual on Uniform Traffic Control Devices for Streets and Highways," and the "Manual of Test Procedures for Materials" in effect on the date of invitation for bids, and the Supplemental Specifications and Recurring Special Provisions indicated on the Check Sheet included herein which apply to and govern the construction of Various Routes; Section Dist 8 Guardrail 2013-1; Various Counties; Contract No. 76F72 and in case of conflict with any part or parts of said Specifications, the said Special Provisions shall take precedence and shall govern.

LOCATION OF PROJECT

This work is located on various State maintained routes district wide in Calhoun, Greene, Jersey, Madison, Bond, Clinton, St. Clair, Monroe, Marion, Washington and Randolph Counties.

DESCRIPTION OF PROJECT

The work to be completed under this contract consists of repairing or replacing existing damaged steel plate beam guardrail and traffic barrier terminals on a work order basis. Guardrail shall be repaired or replaced in accordance with the details and standards in the plans.

Other items of work include: sand barrels and cable median.

MONTHLY LABOR SUMMARY AND ACTIVITY REPORTING SYSTEM

Effective: 1-1-1995

Revised June 2001

I. Monthly Labor Summary Report, Form SBE 148

The prime contractor and each first and second tier sub-contractor, (hereinafter referred to as "subcontractor") shall submit a certified Monthly Labor Summary Report directly to the District Engineer.

This report is in lieu of submittal of the Monthly Workforce Analysis Report, Form SBE 956.

This report must be received in District Eight no later than the tenth day of the next month.

This Report shall be submitted by the prime contractor and each subcontractor, for each consecutive month, from the start, to the completion of their work on the contract.

The data source for this Report will be a summation of all personnel and hours worked on each subject contract for the month based on weekly payrolls for that month.

The Monthly Labor Summary Report is required to be submitted in one of the following formats:

- a.) For contractors having IDOT contracts valued in the aggregate at \$250,000 or less, the report may be typed or clearly handwritten using Form SBE 148 for submittal to the District Engineer for District Eight.
- b.) For contractors having IDOT contracts valued in the aggregate at more than \$250,000, the report must be submitted in a specific "Fixed Length Comma Delimited ASCII Text File Format". The subject file format is detailed on the next page. Submittal of this file may be by 3.5 inch disk, modem, or by e-mail.

II. Monthly Contract Activity Report, Form SBE 248

The prime contractor and each subcontractor shall submit a monthly report directly to the District Engineer reflecting their contract activity on all Illinois Department of Transportation contracts they have in force in District Eight.

This report shall be submitted for each consecutive month, from the start, to the completion of all contracts in District Eight.

The report must be received in the District Office no later than the tenth day of the next month.

Monthly Labor Summary and Activity Reporting System Codes and Formats

Indicated below for your reference are the Employee Codes and File Formats required for this system.

I.) Monthly Labor Summary Report, Form SBE 148

The following employee codes are to be used to identify each individual on the Summary Report:

1. **Gender:** M - Male F - Female
2. **Ethnic Group:** 1 - White 2 - Black 3 - Hispanic
4 - American Indian/Alaskan Native 5 - Asian/Pacific Islander
3. **Work Classification:** OF - Official SU - Supervisor FO - Foremen
CL - Clerical CA - Carpenter EO - Operator ME - Mechanic
TD - Truck Driver IW - Ironworker PA - Painter OT - Other
EL - Electrician PP - Pipefitter TE - Technical LA - Laborer
CM - Cement Mason
4. **Employee Status:** O - Owner Operator J - Journeyman
C - Company A - Apprentice T - Trainee

Specific “Fixed Length Comma Delimited ASCII File Format”

| Order | Field Name | Type | Size |
|-------|-----------------------------|------|------|
| 1 | Contractor Number | A | 4 |
| 2 | Contractor Reference Number | A | 6 |
| 3 | Contract Number | A | 5 |
| 4 | Period (07/28/2000) | D | 10 |
| 5 | SSN (111-11-1111) | A | 11 |
| 6 | Name | A | 40 |
| 7 | Gender | A | 1 |
| 8 | Ethnic Group | A | 1 |
| 9 | Work Classification | A | 1 |
| 10 | Employee Status | A | 1 |
| 11 | Total Hours (000060.00) | N | 10 |

File Name Conventions: (Contractor Number + Report Month/Year).Txt
i.e. 20001298.Txt

II.) Monthly Contract Activity Report, Form SBE 248

The following activity codes are to be used to identify the contractor’s contract status each month on the Monthly Activity Report, Form SBE 248:

- A. Contract Status: 1 - Not Started 2 - Active 3 - No Work
 4 - Suspended 5 - Complete

Failure to comply with this special provision may result in the withholding of payments to the contractor, and/or cancellation, termination, or suspension of the contract in whole or part.

Compliance with this Special Provision shall be considered incidental to the cost of the contract and no additional compensation will be allowed for any costs incurred.

All prime and subcontractors having contracts in the aggregate exceeding \$250,000 must provide a “Fixed Length Comma Delimited ASCII File” for approval prior to the start of construction.

This Special Provision must be included in each subcontract agreement.

The Department of Transportation is requesting disclosure of information necessary to accomplish the statutory purpose as outlined under 23CFR part 230 and 41CFR part 60.4 and the Illinois Human Rights Act. Disclosure of this information is REQUIRED. Failure to comply with this special provision may result in the withholding of payments to the contractor, and/or cancellation, termination, or suspension of the contract in whole or part.

Compliance with this Special Provision shall be considered incidental to the cost of the contract and no additional compensation will be allowed for any costs incurred.

This Special Provision must be included in each subcontract agreement.

TRAFFIC CONTROL PLAN

Effective: July 12, 1993

Revised: May 12, 1997

Traffic control shall be in accordance with the applicable sections of the "Standard Specifications for Road and Bridge Construction", the applicable guidelines contained in the "National Manual on Uniform Traffic Control Devices for Streets and Highways", Illinois Supplement to the National Manual of Uniform Traffic Control Devices, these Special Provisions, and any special details and Highway Standards contained herein and in the plans.

Special attention is called to Articles 107.09 and 107.14 of the "Standard Specifications for Road and Bridge Construction" and the following Highway Standards relating to traffic control:

| | | | | | |
|--------|--------|--------|--------|--------|--------|
| 701001 | 701006 | 701011 | 701101 | 701106 | 701201 |
| 701301 | 701400 | 701406 | 701421 | 701701 | 701901 |

In addition, the following Special Provision(s) will also govern traffic control for this project:

- Construction and Maintenance Sign Supports
- Penalty During Peak Hours
- Changeable Message Sign, Special
- Automated Flagger Assistance Device
- Flagger at Side Road and Entrances

Traffic Control and Protection Standard 701201 – Traffic Control for two lane rural highways shall be provided in accordance with Standard 701201.

Traffic Control and Protection Standard 701400 – Traffic Control for approach to lane closure on Interstate highways and expressways shall be provided in accordance with Standard 701400.

Traffic Control and Protection Standard 701406 – Traffic Control for lane closure on Interstate highways and expressways shall be provided in accordance with Standard 701406.

Traffic Control and Protection Standard 701421 – Traffic Control for lane closure on multilane non-Interstate highways shall be provided in accordance with Standard 701421.

Traffic Control and Protection Standard 701701 – Traffic Control for urban lane closure at multilane intersection shall be provided in accordance with Standard 701701.

Traffic Control and Protection will be paid for at the contract unit price lump sum for TRAFFIC CONTROL AND PROTECTION STANDARD 701201, TRAFFIC CONTROL AND PROTECTION STANDARD 701406, TRAFFIC CONTROL AND PROTECTION STANDARD 701421, TRAFFIC CONTROL AND PROTECTION STANDARD 701701 at the location specified.

CONSTRUCTION AND MAINTENANCE SIGN SUPPORTS

Effective: April 21, 1981

Revised: November 1, 2006

This work shall be done according to Section 1106 of the Standard Specifications and Highway Standard 702001 except as herein modified.

All construction signs mounted on permanent support for use in temporary traffic control having an area of 10 square feet (1 square meter) or more shall be mounted on two 4 in x 4 in (100 mm x 100 mm) or two 4 in x 6 in (100 mm x 150 mm) wood posts.

Type A metal post (two for each sign) conforming to Article 1006.29 of the Standard Specifications may be used in lieu of wood posts. Type A metal posts used for these signs may be unfinished.

This work shall not be paid for separately; but shall be considered included in the cost of the traffic control items in this contract.

STATUS OF UTILITIES TO BE ADJUSTED

| NAME AND ADDRESS OF UTILITY | TYPE | LOCATION | ESTIMATED DATE RELOCATION COMPLETED |
|-----------------------------|------|----------|-------------------------------------|
| NO UTILITIES TO BE ADJUSTED | | | |

NO UTILITIES TO BE ADJUSTED

The above represents the best information of the Department and is only included for the convenience of the bidder. The applicable provisions of Sections 102, 103, and Articles 105.07 and 107.20 of the Standard Specifications for Road and Bridge Construction shall apply.

If any utility adjustment or removal has not been completed when required by the Contractor's operation, the Contractor should notify the Engineer in writing. A request for an extension of time will be considered to the extent the Contractor's operations were affected.

TERM OF CONTRACT

The term of this contract shall start on date of contract execution and end one calendar year later.

PROSECUTION OF THE WORK

The Resident will issue a work order to the Contractor prior to the Contractor proceeding with any work on this contract.

CONTROL OF WORK

The Department may conduct frequent inspections of the respective work order locations to determine if the Contractor is performing repairs promptly and satisfactorily and in the manner specified in the contract. A final inspection will be made by the Department of all work locations and final quantities can be adjusted at that time.

The Department reserves the right to place maximum or minimum limits on the work force and/or equipment utilized by the Contractor to execute a work order.

COMPLETION DATE

The Contractor shall schedule his/her operations in order to complete all work orders issued during the Term of Contract, including all clean-up work and open all roadways to traffic on or before one month after the term of the contract expires.

The provisions of Article 108.09 of the Standard Specifications shall apply to both contract completion dates.

FAILURE TO COMPLETE OR REPAIR – LIQUIDATED DAMAGES

Time is of the essence in the completion of each work order issued by the Department. Failure to make timely repairs will cause public inconvenience, endanger the public safety and subject the Department to public criticism. All repairs shall be completed within the completion time designated for each work order. The Contractor understands and agrees that performance will be expected in varying amounts and at various locations on the roadways designated in the contract in accordance with the work orders issued by the Resident.

Should the Contractor fail to complete the work order within the completion time stipulated, the Contractor shall be liable to the Department for liquidated damages as specified in the following amounts:

| WORK ORDER AMOUNT | | LIQUIDATED DAMAGES PER DAY |
|--------------------------|------------------|-----------------------------------|
| From More Than | To And Including | |
| \$0 | \$500 | \$25 |
| \$500 | \$1000 | \$50 |
| \$1000 | And over | \$100 |

The Department will deduct these liquidated damages from the monies due or to become due to the Contractor from the Department.

All repairs in progress may be halted immediately by the Resident and completion will not be permitted until the Contractor complies with the terms and condition of the contract.

Any repairs completed in disregard of the conditions specified under this contract can result in the total non-payment for the job or in the partial payment of an amount determined by the Resident.

No additional compensation will be given for compliance with the completion date. The cost shall be considered included in the contract.

WORK DURING PEAK HOURS

Contractor will be permitted to work on any day from dawn to dusk unless work requires a lane restriction in a high volume area in which work may be restricted to non-rush hours.

Due to extremely high volume of traffic and on-going construction work on the Metro-St. Louis area river bridges and approaches and urban interstates, the following traffic control restrictions shall apply.

The Contractor shall have all lanes of traffic open during peak hours in the appropriate direction. The Contractor will not be allowed to conduct any type of operation in the open lanes or any type of operation that would impede the flow of traffic during peak hours. Peak hours are defined as:

| | | |
|------------------------|--------------------------------|--------------------------------|
| I-55-70, I-64, I-270 | 6:00 a.m. to 9:00 a.m. WB | 3:00 p.m. to 6:00 p.m. EB |
| I-255 | 6:00 a.m. to 9:00 a.m. NB & SB | 3:00 p.m. to 6:00 p.m. NB & SB |
| IL 15 | 6:00 a.m. to 9:00 a.m. WB | 3:00 p.m. to 6:00 p.m. EB |
| IL 3 (Waterloo to PSB) | 6:00 a.m. to 9:00 a.m. NB | 3:00 p.m. to 6:00 p.m. SB |
| IL 3 (PSB to I-270) | 3:00 p.m. to 6:00 p.m. NB | 6:00 a.m. to 9:00 a.m. SB |

For all routes not listed above, the following will apply.

1. For westbound and southbound traffic, no work or crews are allowed on the pavement between the hours of 6:00 a.m. and 9:00 a.m., Monday through Friday.
2. For eastbound and northbound traffic, no work crews are allowed on the pavement between the hours of 3:00 p.m. and 6:00 p.m., Monday through Friday.
3. Or at the direction of the Department.

PENALTY DURING PEAK HOURS

If the Contractor fails to have all lanes of traffic open during the peak hour for traffic or conducts operations that will impede the flow of traffic during peak hours, a monetary penalty shall be assessed to the Contractor. The penalty shall be \$500 for each 15-minute period or a portion thereof during the peak hours.

WORK ZONE LANE CLOSURE REQUEST

The Contractor will submit a lane closure request form for the work in the areas above. The IDOT Field Technician/Inspector will submit a work zone lane closure to the Department before 2:00 p.m. the day before the work zone will be implemented. The Department will review the request and will either approve or reject the request. If the Department rejects the request, the Contractor will not be allowed to implement the work zone.

All personnel, equipment and all traffic control shall be removed from lanes during the above hours and no additional compensation shall be allowed for meeting these requirements.

Conformance to these traffic control and protecting standards will not be paid for as separate item, but will be considered incidental to the contract.

The Contractor must notify Field Technician/Inspector at (618) 346-3262 or by fax number (618) 346-3299 of the scheduling of work one workday prior to repair. The jobs should be listed in order of repair. A penalty of the loss of traffic control value for the project will be assessed if work is started prior to notification. If no traffic control is associated with the project, a penalty of \$100 will be assessed for each start of work prior to notification. Verification of telephone contact may be made by facsimile machine to District Headquarters, Bureau of Operations, at Fax Number (618) 346-3299.

Damaged areas to be repaired will be identified in orange fluorescent paint and/or survey ribbon. The work order number should be visible at the repair site.

The traffic control standard recommended is based on the Department's estimate of the nature of work, duration and equipment required to perform the repairs. Any deviation must remain in compliance to the Standard Specifications for Road and Bridge Construction Standard Specifications for Traffic Control Items, and the Manual on Uniform Traffic Control Devices, most recent edition and prior approval by the Department is required.

WORK ZONE LANE CLOSURE REQUEST

Must be called Jane Morgando (618-346-3262) or fax (618-346-2299) to IDOT by 2:00 P.M. for daytime closure
(1:00 PM Friday for Sat, Sun, & Mon closures), 11:00 AM for same night
DO NOT COMBINE CLOSURES USE INDIVIDUAL SHEETS FOR EACH HIGHWAY

Date(s) of Closure Night

>>> * Use tomorrow's date if closure is after 4 P.M. <<<<

⇔ HIGHWAY & DIRECTION ⇔

| | | |
|--|--|--|
| <input type="checkbox"/> I 55/70 <input type="checkbox"/> I 64 <input type="checkbox"/> I 70 <input type="checkbox"/> I 255 <input type="checkbox"/> I-270 <input type="checkbox"/> IL 3 <input type="checkbox"/> IL 15 <input type="checkbox"/> MLK Bridge | <input type="checkbox"/> EB <input type="checkbox"/> WB <input type="checkbox"/> EB <input type="checkbox"/> WB <input type="checkbox"/> EB <input type="checkbox"/> WB <input type="checkbox"/> NB <input type="checkbox"/> SB <input type="checkbox"/> EB <input type="checkbox"/> WB <input style="width: 100px; height: 15px;" type="text"/> <input type="checkbox"/> NB <input type="checkbox"/> SB <input type="checkbox"/> EB <input type="checkbox"/> WB <input type="checkbox"/> EB <input type="checkbox"/> WB | <input type="checkbox"/> POPLAR ST. COMPLEX <input type="checkbox"/> I 55/70 (Mainline) <input type="checkbox"/> EB <input type="checkbox"/> WB <input type="checkbox"/> WB C-D <input type="checkbox"/> EB C-D <input type="checkbox"/> Ramp 'G' Main St. to WB C-D <input type="checkbox"/> Ramp 'S' WB C-D to Tudor <input type="checkbox"/> Ramp 'D' EB C-D to Tudor <input type="checkbox"/> Ramp 'H' EB C-D to 4 th St. <input type="checkbox"/> Ramp 'A' Tudor West to PSB <input type="checkbox"/> Ramp 'M' North to PSB <input type="checkbox"/> Ramp 'P' North to EB C-D <input type="checkbox"/> Ramp 'O' WB C-D to IL 3 South <input type="checkbox"/> Ramp 'N' EB C-D to IL 3 South |
|--|--|--|

| | | | |
|------------------|--|-------------|------------|
| LOCATION: | | FROM | To: |
|------------------|--|-------------|------------|

| | | |
|--|---|---|
| LANES: <<Left In. to Right In>> <input type="checkbox"/> 1 <input type="checkbox"/> 2 <input type="checkbox"/> 3 <input type="checkbox"/> 4 <input type="checkbox"/> 5/6 | SHOULDER <input type="checkbox"/> Left <input type="checkbox"/> Right | RAMPS <input type="checkbox"/> Full <input type="checkbox"/> Exit <input type="checkbox"/> Partial (1/2) <input type="checkbox"/> Entrance |
| <input type="checkbox"/> MOVING <input type="checkbox"/> STATIONARY | | |

TIMES: From: _____ A.M. / P.M. To: _____ A.M. / P.M.
 From: _____ A.M. / P.M. To: _____ A.M. / P.M.

| CLOSURE DESCRIPTION | | | |
|---------------------|-------|---|---|
| | LANE# | M | M |
| | LANE# | M | M |
| | LANE# | M | M |
| | LANE# | M | M |

| | |
|----------------------------|--|
| CONTRACTOR/YARD: | |
| TRAFFIC CONTROL BY: | |
| SUBMITTED BY: | |

| | |
|-------------------|------------------|
| PHONE NO: | FAX NO: |
| MOBILE NO: | PAGER NO: |

Peak Hour Restrictions; Two (2) Lanes shall remain open at all times

| | | |
|-----------------------------------|----------------------|----------------------|
| I 55/70, I 64, I 270, MLK Bridge | 6:00 a to 9:00a WB | 3:00p to 6:00p EB |
| I 255 from I 270 to JB Bridge | 6:00a to 9:00a NB&SB | 3:00p to 6:00p NB&SB |
| Ill. 3 from Ill.158 to I 270 | 6:00a to 9:00a NB&SB | 3:00p to 6:00p NB&SB |
| Ill. 15 from Ill. 159 to Missouri | 6:00a to 9:00a WB | 3:00p to 6:00p EB |

INTERPRETATION OF QUANTITIES AND PAYMENT

The quantities in the Summary of Quantities are approximate and include items necessary to repair existing damaged guardrail and an estimate of items necessary to repair damage that may occur during the Term of Contract.

The quantities in the Summary of Quantities may be increased, decreased or deleted. Adjustments in contract unit prices will not be made due to an increase, decrease or deletion of items.

Payment for the work under this contract shall be made in accordance with the schedule of prices in the contract and as herein after described. Prices shall include all labor, materials and equipment necessary to complete the work satisfactorily. Before any payment for work is authorized, for a given work order, all repairs must be completed satisfactorily and the guardrail installation must be functional as intended.

The Contractor is hereby informed and shall understand that payment will be made only for actual quantities utilized and accepted as satisfactory.

WORK ORDER

No work, except for priority work, is to be performed by the Contractor without the issuance of a work order authorizing the work. Work orders may be issued for this during the Term of Contract. A work order will show the class of work, date issued to the Contractor, claim number, location, item description, and quantity of removals or repairs to be made. Only the amount of replacement or repairs shown on the work order is to be done by the Contractor. If, at the time repairs are being made, it is found that additional work is needed, prior approval must be obtained from the Resident before work is done. Any additional work done by the Contractor, without prior approval of the Resident, will not be paid. A sample work order (project identification sheet) is included in the special provisions.

The Contractor shall contact the Resident by telephone no later than 7:00 AM each work day, or at another time specified by the Resident, to coordinate and obtain approval for daily work. The Contractor shall not revise the sequence of daily planned work without the Resident's approval. The Contractor shall contact the Resident (on a Monday through Friday) and at least 24 hours in advance of Saturday, Sunday or holiday work.

The Resident shall issue all work orders except priority work to the Contractor at a location or method as approved by the Resident.

The Contractor shall inspect in detail the site of the work to determine the traffic control and protection requirements before proceeding with the work.

After the work is completed, the work order will be signed and dated by the Resident when the work has been inspected and accepted. The Contractor will be given one copy of the work order for his/her records.

Priority work will be initiated by a verbal order from the Resident. This verbal order will always be confirmed by a written work order.



PROJECT IDENTIFICATION SHEET

Claim # : C-12 Date: _____
 Location : _____

 County : _____
 Appr. Shoulder Width : _____



TRAFFIC CONTROL

| | |
|---------------------------------|--|
| 701421 <input type="checkbox"/> | 701201 <input type="checkbox"/> |
| 701408 <input type="checkbox"/> | 701701 <input type="checkbox"/> |
| 701101 <input type="checkbox"/> | No Work 8-9AM <input type="checkbox"/> |
| | No Work 3-6PM <input type="checkbox"/> |

| ITEM CODE | QUANTITY | UNIT COST | TOTAL | DESCRIPTION OF WORK |
|---------------|----------|-----------|-------|--|
| | | | | GUARDRAIL BLOCKS |
| | | | | RAIL ELEMENT PLATES |
| | | | | TRAFFIC BARRIER TERM TYPE 1 SPL (FLARED) |
| | | | | REPAIR T.B. TYPE 1 SPECIAL - POST |
| | | | | REPAIR T.B. TYPE 1 SPL. RAIL ELEMENT PLATE |
| | | | | TRAFFIC BARRIER TERM. TYPE 5 |
| | | | | SINGLE END SECTION |
| | | | | TRAFFIC BARRIER TERM TYPE 1B |
| | | | | STEEL POST |
| | | | | STEEL POST, ATTACHED TO STRUCTURE |
| | | | | STEEL POST (SPECIAL) |
| | | | | REMOVAL/REINSTALLATION OF EXISTING IMPACT ATT |
| | | | | REPAIR T.B. TERM. TYPE 1 SPL (TANGENT) |
| | | | | REPAIR T.B. TERM TYPE 2 |
| | | | | FURNISHING AND INSTALLING EXTRUDER HEAD |
| | | | | CABLE GUARD POST |
| | | | | HIGH TENSION CABLE POST REPAIR |
| | | | | REPAIR HIGH TENSION CABLE |
| | | | | MEDIAN CABLE |
| | | | | TRAFFIC BARRIER TERM TYPE 2 |
| | | | | REPLACE HIGH TENSION CABLE GUARDPOST FOUNDATION |
| | | | | |
| | | | | |
| | | | | LOCATE UNDERGROUND CABLE SPECIAL |
| | | | | ADDITIONAL WARNING LIGHTS BILLED <input checked="" type="radio"/> Yes <input type="radio"/> No |
| | | | | |
| TOTAL: | | | | |

Note: All miscellaneous nuts, bolts, hardware, etc. are assumed required, and incidental.

Office Use Only

Survey _____
 Completed _____ Accepted _____ By _____

CLASS OF WORK

1. Priority Work

Priority work is defined as work that is required to correct a condition which is an immediate hazard to the public, or is designated by the Resident to be an immediate hazard of such severity that life and/or property are potentially endangered and first priority corrective action is required.

The location of guardrail and appurtenances to be repaired as priority work shall be determined by the Resident and may be required at any time between the starting date and the completion date.

2. Regular Work

Regular Work is defined as work that involves those situations where the amount or nature of damage does not pose an immediate hazard to the public. Work of this type shall generally be grouped by locations for efficiency of repair.

COMPLETION TIME FOR WORK ORDERS

The Contractor shall schedule his/her operations in order to complete a Priority Work Order within 24 to 48 hours after the date issued.

The Contractor shall schedule his/her operations in order to complete a Regular Work Order within fifteen (15) calendar days after the date issued.

CALENDAR DAYS

A calendar day is every day shown on the calendar and starts at 12:00 midnight and ends at the following 12:00 midnight, twenty-four (24) hours later.

A calendar day will be charged for every day shown on the calendar except as follows:

- a) When the temperature, as officially reported by the Bureau of Operations in District 8, reaches zero degrees Fahrenheit or below during any portion of that day.
- b) When weather conditions, emergency conditions and/or unforeseen highway operational reasons prevent shoulder or lane closures required for the work.
- c) When the Contractor requests and is denied approval from the Department for lane, ramp and shoulder closures required for the work.
- d) During any legal holiday period as defined in Article 107.09 of the Standard Specifications for Road and Bridge Construction.

The Contractor shall petition the Resident in writing within 48 hours for each non-chargeable calendar day request. Failure to petition in time shall be just cause to deny the petition. Approval of non-chargeable calendar day requests shall be by the sole determination of the Resident.

CONTRACTOR'S RESPONSIBILITY FOR DAMAGE TO EXISTING STRUCTURES

Extreme care shall be exercised when driving posts since there are drainage structures, storm sewers, sign foundations, culverts, electrical and surveillance conduit, and other existing objects within the immediate work limits of this project. Operations are to be conducted in a manner, which will minimize damage to the surrounding area.

The Contractor shall be held responsible for any damage to existing structures resulting from his operations. The Contractor shall, at his own expense, restore the damaged structures to a

condition equal to that existing before such damaged was done by repairing, rebuilding or replacing it as directed by the Resident. Where, in the opinion of the Resident, the Contractor through his operations has excessively damaged the surrounding area, the Contractor shall restore the surrounding area to a condition meeting the satisfaction of the Resident at his own expense.

No extra compensation will be allowed the Contractor for compliance with this requirement.

THE CONTRACTOR'S LIABILITY

The trees, shrubs and seeded areas on or adjacent to the work should be protected from unnecessary damage by the Contractor's operations in a manner satisfactory to the Resident. The Contractor shall be responsible for the damage or destruction of property of any character resulting from neglect, misconduct, or omission in the execution or non-execution of the work, or caused by defective work or the use of unsatisfactory materials. Such responsibilities shall not be released until the work has been completed and accepted in accordance with the requirements of these Special Provisions.

The Contractor shall repair damage to any property, public or private, to a condition equivalent to its original condition at no cost to the Department. This work shall be done according to the applicable sections of the Standard Specifications or to the satisfaction of the Resident.

PROTECTION FOR DAMAGED LOCATIONS

The Contractor shall be required to install and maintain barricades with flashing lights at priority locations that have not been repaired within (7) seven calendar days after the date of the issuance of the work order.

The Department will initially have barricades installed at the priority locations and the Contractor will have the option to assume the cost of these rented barricades after the (7) seven days referred to above or have the barricades replaced with others. If the Contractor fails to exercise either of the above options, he shall be liable to the Department in the amount of \$1.00 per barricade per day, not as a penalty but as liquidated damages.

REALIGNING POSTS

At designated locations of steel plate beam guardrail where the existing undamaged posts can be realigned and restored to the proper alignment without removing said posts from the ground, the posts shall be so plumbed and realigned by a method which does not require the pulling of the posts out of the existing post holes. The posts shall be straightened with their front faces on the line shown on the plans, or as ordered by the Resident and with their tops and bolt holes at the correct height so that the rail element plates bolted to them will be parallel to the surface of the shoulder.

The work as described herein shall be included in the contract unit bid price for the pay items involved.

REMOVAL OR REPAIR OF GUARDRAIL

No guardrail shall be removed from State right-of-way under this contract unless each section to be removed is clearly marked for removal. A representative of the Department of Transportation will paint an "X" on each piece of guardrail to be removed. The type and quantity of each piece so marked will be listed on a work order. This work order, when issued to the Contractor by a State Representative, will be authorization for the removal or repair of the guardrail.

Material removed from State right-of-way will be disposed of by the Contractor outside the right-of-way limits at locations provided by him. None of this material shall be reused on this project. The removal, transportation and storage of material removed from the State right-of-way under this contract will not be paid for separately, but the cost thereof shall be included in the contract unit price for replacement items.

New material shall conform to the dimensions and shapes of the material to be replaced except as noted, and shall meet the requirements as specified under each item in these Special Provisions and on the plans. Damaged guardrail that has been removed shall be totally and completely replaced on the same day that it has been removed.

Any ground bituminous material adjacent to a concrete footing, which is removed or disturbed during the removal operations, shall be restored to its original condition and to the satisfaction of the Resident after the work has been completed. This restoration will not be paid for separately but shall be considered incidental to this item of work.

After the work is completed, the Contractor shall mark a rail element plate in the repair area using a paint stick with the work order number and date of repairs.

Immediately after the specified repairs have been made, all nut, bolts, washers, posts, rail elements and any other guardrail components, damaged or undamaged, which are to be scrapped, shall be completely removed from the State right-of-way. Failure to do so will be cause for rejection of work.

The Contractor shall install and maintain a minimum of two Type I or Type II Barricades with flashing warning lights for each direction of traffic per damaged location. Additional barricades will be required for each additional length of 25 feet of damaged guardrail per direction of traffic or as directed by the Resident.

The cost of furnishing, installing, maintaining and removal of the Type I or Type II Barricades will not be paid for separately, but shall be included in the contract unit bid price for the pay items involved.

FINAL CLEAN UP

Final clean up shall conform to the requirements set forth in Article 104.06 of the Standard Specifications.

This will be required at each location where repair has been completed.

This work will not be paid for separately but shall be included in the contract unit bid price for the pay items involved.

CONTRACTOR CONTACTS

The Contractor shall furnish a cellular phone with service meeting the approval of the Resident. At the Contractor's option, the Contractor shall also provide the Resident with either a digital camera or Polaroid camera with film as need by the Engineer. The cost of the above items shall be included in the contract unit bid price for the pay items involved and no additional compensation will be allowed.

CLEARING

The Contractor is hereby informed and shall understand that at some locations of repairs shrubs, brush, weeds, and other vegetation may be encountered that must be removed in order to make the necessary repairs. The cleaning of shrubs, brush, weeds and other vegetation will not be paid for separately but shall be included in the contract unit bid price for the pay items involved. All work shall be done in a neat and workmanlike manner and to the satisfaction of the Resident.

GUARDRAIL BLOCKS

This work consists of removing and replacing existing damaged guardrail block-outs. This work shall be done as directed by the Resident and according to Sections 630 and 632 of the Standard Specifications, the detail in the plans, and this provision.

Replacement block-outs shall conform to the details and standards included in the plans.

Removal, furnishing, and installing of all bolts, nuts, washers and other hardware necessary to complete the work will not be paid for separately, but shall be included in the contract unit bid price for the pay items involved.

This work shall be paid for at the contract unit price per each for GUARD RAIL BLOCKS.

RAIL ELEMENT PLATES

This work consists of removing all sections of damaged rail element plates including all associated hardware, and furnishing and installing new guardrail elements including all necessary hardware at locations as directed by the Resident. This work shall be done as directed by the Resident and according to applicable sections of the Standard Specifications, the plans, and this provision.

Plates, nuts, bolts, washers and other hardware shall be galvanized and shall match the original and adjacent installation as to type and design.

The Contractor shall adjust and realign existing rail element plates adjacent to rail elements removed and replaced as directed by the Resident. Unbolting, bolting, adjusting, realigning or any other work necessary to accomplish the desired realignment shall be included in the contract unit bid price for the pay items involved.

The furnishing and installing of all bolts, nuts, washers and other hardware necessary to comply with the above mentioned Special Provision will not be paid for separately, but shall be included in the contract unit bid price for the pay items involved.

In order to clarify measurement and payment for work, the standard length of rail element plate shall be considered to be 12'-6". In the event existing damaged rail element plates to be removed and replaced measures 25 feet in length, they shall be considered as two (2) rail element plates of standard 12'-6" length.

This work shall be paid for at the contract unit price each for RAIL ELEMENT PLATES.

TRAFFIC BARRIER TERMINAL, TYPE 1, SPECIAL

This work shall consist of furnishing and installing a Traffic Barrier Terminal Type 1, Special of the type specified by the Resident according to Section 631 of the Standard Specifications, the details in the plans, and this provision.

Delete all references to Type 1 terminal in Section 631 in the Standard Specifications.

All Terminals shall meet the testing criteria contained in the National Cooperative Highway Research Program (NCHRP) Report 350 and be approved by the Department.

The terminal shall be installed according to the manufacturer's specifications and shall include all necessary transitions between the terminal and the item to which it is attached.

The terminals shall follow the manufacturer's specifications for installation as to type and number of posts, foundation tubes, and soil plates.

The terminal section shall provide a minimum length of need of 37.5 ft.

Included in this item is the complete removal of an existing damaged or undamaged terminal section having a length of approximately fifty (50) feet, where the rail element is twisted 90 degrees, terminating at an end post flush with the ground. All posts, rail element plates and related components of the existing terminal section, including the steel end post, shall be removed. The existing steel end post encountered may be set in a concrete anchor or may have been driven in accord with the alternate requirements permissible at the time of the guardrail installation. In the event a concrete anchor is encountered, said concrete anchor shall be completely removed. After the concrete anchor is removed, the remaining hole shall be filled with sand or other suitable material approved by the Resident.

Also included in this item is the complete removal of an existing damaged or undamaged Traffic Barrier Terminal Type 1, Traffic Barrier Type 1A, Traffic Barrier Terminal Type 1, Special and any guardrail necessary to accommodate the new Traffic Barrier Terminal Type 1, Special. The Resident will make this determination and inform the Contractor prior to commencing repairs. All old posts shall be removed and the remaining holes shall be filled with sand or other suitable material approved by the Resident.

The Contractor shall adjust and realign existing rail element plates and posts adjacent to the new traffic barrier terminal, as directed by the Resident. Unbolting, bolting, adjusting, realigning, guardrail removal, or any other work necessary to accomplish the desired realignment shall be included in the contract unit bid price for the pay items involved.

This item shall also include the furnishing and installing of a Terminal Marker - Direct Applied which shall comply with the applicable portions of the Recurring Special Provision for GUARDRAIL AND BARRIER WALL DELINEATION. This work shall be included in the contract unit bid price for the pay items involved.

This work shall be paid for at the contract unit price each for TRAFFIC BARRIER TERMINAL TYPE 1, SPECIAL (TANGENT) and for TRAFFIC BARRIER TERMINAL TYPE 1, SPECIAL (FLARED), which price shall include all labor, equipment and material to satisfactorily complete the work as described herein.

REPAIR TRAFFIC BARRIER TERMINAL TYPE 1 SPECIAL – POST

This work consists of removal and replacement of a damaged post, block and related hardware of a Traffic Barrier Terminal Type 1 Special at the locations as specified by the Resident in accordance with the Standard Specifications, the plans, and this provision.

The Contractor shall adjust and realign existing rail element plates and posts adjacent to the traffic barrier terminal repaired, as directed by the Resident. Unbolting, bolting, adjusting, realigning or any other work necessary to accomplish the desired realignment shall be included in the contract unit bid price for the pay items involved.

The cost of removing and replacing all damaged components from the approach nose of the terminal, up to and including the second post and the first 25 feet of guardrail will be paid for separately.

Soil tubes shall be included in the cost of this item.

This work will be paid for at the contract unit price each for REPAIR TRAFFIC BARRIER TERMINAL TYPE 1 SPECIAL - POST, which price shall include all labor, equipment and material necessary to satisfactorily complete the work as described herein.

REPAIR TRAFFIC BARRIER TERMINAL TYPE 1 SPECIAL – RAIL ELEMENT PLATE

This work consists of removal and replacement of 25 feet of damaged rail element plate and related hardware of a Traffic Barrier Terminal Type 1, Special at the locations as specified by the Resident in accordance with the Standard Specifications, the plans, and this provision.

The Contractor shall adjust and realign existing rail element plates and posts adjacent to the traffic barrier terminal repaired, as directed by the Resident. Unbolting, bolting, adjusting, realigning or any other work necessary to accomplish the desired realignment shall be included in the contract unit bid price for the pay items involved.

The cost of removing and replacing all damaged components from the approach nose of the terminal, up to and including the second post and the first 25 feet guardrail will be paid for separately.

This work will be paid for at the contract unit price each for REPAIR TRAFFIC BARRIER TERMINAL TYPE 1 SPECIAL - RAIL ELEMENT PLATE, which price shall include all labor, equipment and material necessary to satisfactorily complete the work as described herein.

TRAFFIC BARRIER TERMINAL, TYPE 5 & 6

This work consists of furnishing and installing a Traffic Barrier Terminal Type 5 or 6 at the locations as specified by the Resident in accordance with Section 631 of the Standard Specifications, the details in the plans, and this provision.

Also included in this item is the complete removal of an existing damaged or undamaged sub standard, Traffic Barrier Terminal Type 5 or Type 6. The Resident will make this determination and inform the Contractor prior to commencing repairs. All posts, rail element plates and related components of the existing terminal section, as well as any length of the guardrail types needed to accommodate the new Traffic Barrier Type 5 or 6 shall be removed. Included in this item are all shims and blocks required by the Resident to facilitate proper attachment to structure walls.

The Contractor shall adjust and realign existing rail element plates and posts adjacent to the new traffic barrier terminal, as directed by the Resident. Unbolting, bolting, adjusting, realigning, guardrail removal, or any other work necessary to accomplish the desired realignment shall be included in the contract unit bid price for the pay items involved.

This work will be paid for at the contract unit price each for TRAFFIC BARRIER TERMINAL, TYPE 5 and TRAFFIC BARRIER TERMINAL, TYPE 6 which price shall include all labor, equipment and material necessary to satisfactorily complete the work as described herein.

SINGLE END SECTION

Refer to Standard 630001. This work consists of removing a damaged steel plate beam guardrail end section or shoe and erecting a new end section or shoe at the same location. This work shall be done as directed by the Resident and according to Sections 630 and 632 of the Standard Specifications, the detail in the plans, and this provision.

The end section is to match the existing and adjacent guardrail as to type and design.

Removal, furnishing, and installing of all bolts, nuts, washers and other hardware necessary to complete the work will not be paid for separately, but shall be included in the contract unit bid price for the pay items involved.

This work shall be paid for at the contract unit price each for SINGLE END SECTION.

TRAFFIC BARRIER TERMINAL, TYPE 2

This work consists of furnishing and installing a Traffic Barrier Terminal Type 2 at the locations as specified by the Resident in accordance with Section 631 of the Standard Specifications, the details in the plans, and this provision.

Included in this item is the complete removal of an existing damaged or undamaged terminal section having a length of approximately twenty-five (25) feet, where the rail element is twisted 90 degrees, terminating at an end post flush with the ground. All posts, rail element plates and related components of the existing terminal section, including the steel end post, shall be removed. The existing steel end post encountered may be set in a concrete anchor or may have been driven in accord with the alternate requirements permissible at the time of the guardrail installation. In the event a concrete anchor is encountered, said concrete anchor shall be completely removed. After the concrete anchor is removed, the remaining hole shall be filled with sand or other suitable material approved by the Resident.

Also included in this item is the complete removal of an existing damaged Traffic Barrier Terminal Type 2. The Resident will make this determination and inform the Contractor prior to commencing repairs.

The Contractor shall adjust and realign existing rail element plates and posts adjacent to the new traffic barrier terminal, as directed by the Resident. Unbolting, bolting, adjusting, realigning,

or any other work necessary to accomplish the desired realignment shall be included in the contract unit bid price for the pay items involved.

This work shall be paid for at the contract unit price each for TRAFFIC BARRIER TERMINAL, TYPE 2, which price shall include all labor, equipment and material necessary to satisfactorily complete the work as described herein.

STEEL POSTS

Refer to Standard 630001. This work consists of removing a damaged guardrail post and erecting a new guardrail post at the same location. This work shall be done as directed by the Resident and according to Sections 630 and 632 of the Standard Specifications, the plans, and this provision.

The proposed guardrail post will match the existing and adjacent guardrail posts as to type, length, and design.

The replacement guardrail post shall conform to the length, size and type of the original installation of the steel plate beam guardrail.

Removal, furnishing, and installing of all bolts, nuts, washers and other hardware necessary to complete the work will not be paid for separately, but shall be included in the contract unit bid price for the pay items involved.

This work shall be paid for at the contract unit price each for STEEL POSTS.

REMOVAL AND REINSTALLATION OF EXISTING IMPACT ATTENUATORS

This work consists of removing and replacing a damaged sand barrels impact attenuator at the locations as specified by the Resident in accordance with the Standard Specifications, the plans, and this provision.

Impact attenuators will be replaced in kind with no additional compensation for the amount of sand used in the various types of barrels used. The spacer or cone to determine the amount of sand is also incidental for this pay item. This work shall be paid for at the contract unit price each for REMOVAL AND REINSTALLATION OF EXISTING IMPACT ATTENUATORS per each barrel which price shall include all labor, equipment, and material necessary to satisfactorily complete the work as described herein.

REPAIR TRAFFIC BARRIER TERMINAL TYPE 1 SPECIAL (TANGENT)

This work consists of removing and replacing all damaged components from the approach nose of the terminal, up to and including the second post and the first 25 feet of rail element plate at the locations as specified by the Resident in accordance with the Standard Specifications, the plans, and this provision.

The Contractor shall adjust and realign existing rail element plates and posts adjacent to or within the traffic barrier terminal repaired, as directed by the Resident. Unbolting, bolting, adjusting, realigning, excavating, filling post holes or any other work necessary to accomplish the desired realignment shall be included in the contract unit bid price for the pay items involved.

This item shall also include the furnishing and installing of a Terminal Marker – Direct Applied, if needed, which shall comply with the applicable portions of the Recurring Special Provision for GUARDRAIL AND BARRIER WALL DELINEATION. This work shall be included in the contract unit bid price for the pay items involved.

The entire 25 feet of guardrail shall be replaced when the existing guardrail is damaged. Replacement of the 25 feet of steel plate beam guardrail shall not be included in the measurement for payment but shall be considered included in the cost of the item. Also included in the cost of this item are cable assemblies, strut, soil tubes, and all other hardware, excluding the extruder head.

The existing extruder head will be reused and reattached to the Traffic Barrier Terminal if undamaged. This work is considered included in the cost of this pay item.

This work will be paid for at the contract unit price per each for REPAIR TRAFFIC BARRIER TERMINAL TYPE 1 SPECIAL (TANGENT), which price shall include all labor, equipment and material necessary to satisfactorily complete the work as described herein.

When the extruder head is damaged, a new extruder head will be paid for separately as FURNISHING AND INSTALLING EXTRUDER HEAD.

EXTRUDER HEAD

This work consists of removal and replacement of a Traffic Barrier Terminal Type 1 Extruder Head as specified by the Resident in accordance with the Standard Specifications, the plans, and this provision.

This work will be used in conjunction with the pay item REPAIR TRAFFIC BARRIER TERMINAL TYPE 1 SPECIAL.

This item shall also include the furnishing and installing of a Terminal Marker – Direct Applied, if needed, which shall comply with the applicable portions of the Recurring Special Provision for GUARDRAIL AND BARRIER WALL DELINEATION. This work shall be included in the contract unit bid price for the pay items involved.

This work will be paid for at the contract unit price per each for EXTRUDER HEAD.

REPAIR TRAFFIC BARRIER TERMINAL TYPE 1 SPECIAL (FLARED) AND TYPE 3A

This work consists of removing and replacing all damaged components from the approach nose of the terminal, up to and including the second post and the first 25 feet of rail element plate at the locations as specified by the Resident in accordance with the Standard Specifications, the plans, and this provision.

The Contractor shall adjust and realign existing rail element plates and posts adjacent to or within the traffic barrier terminal repaired, as directed by the Resident. Unbolting, bolting, adjusting, realigning, excavating, filling post holes or any other work necessary to accomplish the desired realignment shall be included in the contract unit bid price for the pay items involved.

This item shall also include the furnishing and installing of a Terminal Marker - Direct Applied, if needed, which shall comply with the applicable portions of the Recurring Special Provision for GUARDRAIL AND BARRIER WALL DELINEATION. This work shall be included in the contract unit bid price for the pay items involved.

The entire 25 feet of guardrail shall be replaced when the existing guardrail is damaged. Replacement of the 25 feet of steel plate beam guardrail shall not be included in the measurement for payment but shall be considered included in the cost of this item. Also included in the cost of this item are cable assemblies, noses, strut, and all other hardware.

The repair of type 3 special shall include repairing an existing C.A.T. system only.

This work will be paid for at the contract unit price per each for REPAIR TRAFFIC BARRIER TERMINAL TYPE 1 SPECIAL (FLARED) and REPAIR TRAFFIC BARRIER TERMINAL TYPE 3A, which price shall include all labor, equipment and material necessary to satisfactorily complete the work as described herein.

REPAIR TRAFFIC BARRIER TERMINAL TYPE 2, 5 AND 6

This work consists of removing and replacing damaged components of existing Traffic Barrier Terminals Type 2, 5 and 6 at the locations as specified by the Resident in accordance with the applicable portions of the Standard Specifications, Standards 631011, 631026, 631031, the plans, and this provision.

The Contractor shall adjust and realign existing rail element plates and posts adjacent to the traffic barrier terminal repaired, as directed by the Resident. Unbolting, bolting, adjusting, realigning, excavating or any other work necessary to accomplish the desired realignment shall be included in the contract unit bid price for the pay items involved.

This work will be paid for at the contract unit price each for REPAIR TRAFFIC BARRIER TERMINAL, of the type specified, which price shall include all labor, equipment, and material necessary to satisfactorily complete the work as described herein.

CABLE GUARDPOSTS

Refer to Standard 636001. This work consists of removing a damaged cable road guardpost and erecting a new cable road guardpost at the same location. This work shall be done as directed by the Resident and according to Sections 636 and 632 of the Standard Specifications, the plans, and this provision.

The proposed cable road guardpost will match the existing and adjacent cable road guardpost as to type, length, and design.

The replacement cable road guardpost shall conform to the length, size and type of the original installation of the cable road guardpost. If required, reflectors, meeting the manufacturer's specifications for the type of guardpost being replaced, or as approved by the Engineer, shall also be included with the replaced guardpost, at a spacing determined by the Engineer.

Reinstalling and retensioning of the cable and all hardware necessary to complete the work including cable splices and turn buckles will not be paid for separately, but shall be included in the contract unit bid price for the pay items involved.

This work shall be paid for at the contract unit price each for CABLE GUARDPOSTS.

HIGH TENSION CABLE ROAD GUARDPOSTS

This work consists of removing a damaged high tension cable road guardpost and erecting a new high tension cable road guardpost at the same location. This work shall be done as directed by the Resident and according to the manufacturer's specifications, the plans, and the special provisions.

The proposed high tension cable road guardpost will match the existing and adjacent high tension cable road guardpost as to type, length, and design.

The replacement high tension cable road guardpost shall conform to the length, size and type of the original installation of the cable road guardpost.

If required, reflectors, meeting the manufacturer's specifications for the type of guardpost being replaced, or as approved by the Engineer, shall also be included with the replaced guardpost, at a spacing determined by the Engineer.

Retensioning of the cable will not be paid for separately, but shall be included in the contract unit bid price for HIGH TENSION CABLE ROAD GUARDPOSTS.

This work shall be paid for at the contract unit price each for HIGH TENSION CABLE ROAD GUARDPOSTS.

STEEL POSTS, ATTACHED TO STRUCTURE

Refer to Standard 630101. This work consists of removing a damaged guardrail post attached to a structure and erecting a new guardrail post attached to a structure at the same location. This work shall be done as directed by the Resident and according to Sections 630 and 632 of the Standard Specifications, the detail in the plans, and this provision.

The proposed and replacement guardrail post is to match the existing and adjacent guardrail posts as to type, length and design.

Removal, furnishing and installing of all bolts, nuts, washers and other hardware necessary to complete the work will not be paid for separately, but shall be included in the contract unit bid price for the pay items involved.

This work shall be paid for at the contract unit price each for STEEL POSTS, ATTACHED TO STRUCTURE.

STEEL POSTS (SPECIAL)

Refer to Standard 630001. This work consists of unbolting the rail elements, removing a guardrail post that could be set in concrete, and furnishing and setting a new guardrail post set in portland cement concrete. This work shall be done as directed by the Resident and according to Sections 630 and 632 of the Standard Specifications, the detail in the plans, and this provision.

Where existing damaged posts are set in concrete, the Contractor shall remove the damaged guardrail post and concrete. The Contractor shall set a new guardrail post of the same length as that removed in concrete on the same alignment and at the proper height to coincide with the adjacent and adjoining guardrail. New guardrail posts shall match the existing installation.

Where existing damaged posts are not set in concrete and are shorter than the length specified in the appropriate standard due to impervious material or underground utilities encountered, the new guardrail posts shall be set in concrete in accordance with the details as shown in Standard 630001 and at the proper height to coincide with the adjacent guardrail. New guardrail posts shall match the existing installation.

This work shall be paid for at the contract unit price each for STEEL POSTS (SPECIAL).

HIGH TENSION CABLE POST REPAIR

This work consists of repairing or replacing of all the necessary hardware on a high tension cable posts at locations specified by the Resident Engineer. This will include all necessary hardware including, but not limited to hairpin and lock plates, J-Bolts and washers at end sections or cable guides.

This work shall be paid for at the contract unit price each for HIGH TENSION CABLE POST REPAIR, which price shall include all labor, equipment and material to satisfactorily complete the work as described herein.

REPAIR HIGH TENSION CABLE

This work consists of re-connecting median cable and replacing any splices, turnbuckles and anchor fittings as needed in order to re-tension the median cable to the manufacturer's specifications as warranted by the system being repaired at locations specified by the Resident Engineer.

This work shall be paid for at the contract unit price per foot for REPAIR HIGH TENSION CABLE.

MEDIAN CABLE

This work consists of installing median cable at locations specified by the Resident Engineer including all necessary hardware according to the manufacturer's specification as warranted by the existing system being repaired.

This work shall be paid for at the contract unit price per foot for MEDIAN CABLE.

LOCATING UNDERGROUND CABLE, SPECIAL

This work shall consist of locating and marking all state owned buried cable.

The Contractor shall take whatever precautions to protect the underground cable from damage during location and construction operations. In the event that the cable is damaged, the Contractor shall replace the cable in a manner satisfactory to the Resident, at his/her own expense.

This work will be paid for at the contract unit price each for LOCATING UNDERGROUND CABLE, SPECIAL, which price shall include locating and marking the underground cable and protecting it from damage during location and construction operations.

AGREEMENT TO PLAN QUANTITY (BDE)

Effective: January 1, 2012

Revise the second paragraph of Article 202.07(a) of the Standard Specifications to read:

“When the plans or work have been altered, or when disagreement exists between the Contractor and the Engineer as to the accuracy of the plan quantities, either party shall, before any work is started which would affect the measurement, have the right to request in writing and thereby cause the quantities involved to be measured. When plan quantities are revised by the issuance of revised plan sheets that are made part of the contract, and the Contractor and the Engineer have agreed in writing that the revised quantities are accurate, no further measurement will be required and payment will be made for the revised quantities shown.”

AUTOMATED FLAGGER ASSISTANCE DEVICES (BDE)

Effective: January 1, 2008

Description. This work shall consist of furnishing and operating automated flagger assistance devices (AFADs) as part of the work zone traffic control and protection for two-lane highways where two-way traffic is maintained over one lane of pavement. Use of these devices shall be at the option of the Contractor.

Equipment. AFADs shall be according to the FHWA memorandum, “MUTCD - Revised Interim Approval for the use of Automated Flagger Assistance Devices in Temporary Traffic Control Zones (IA-4R)”, dated January 28, 2005. The devices shall be mounted on a trailer or a moveable cart and shall meet the requirements of NCHRP 350, Category 4.

The AFAD shall be the Stop/Slow type. This device uses remotely controlled “STOP” and “SLOW” signs to alternately control right-of-way.

Signs for the AFAD shall be according to Article 701.03 of the Standard Specifications and the MUTCD. The signs shall be 24 x 24 in. (600 x 600 mm) having an octagon shaped “STOP” sign on one side and a diamond shaped “SLOW” sign on the opposite side. The letters on the signs shall be 8 in. (200 mm) high. If the “STOP” sign has louvers, the full sign face shall be visible at a distance of 50 ft (15 m) and greater.

The signs shall be supplemented with one of the following types of lights.

- (a) Flashing Lights. When flashing lights are used, white or red flashing lights shall be mounted within the “STOP” sign face and white or yellow flashing lights within the “SLOW” sign face.
- (b) Stop and Warning Beacons. When beacons are used, a stop beacon shall be mounted 24 in. (600 mm) or less above the “STOP” sign face and a warning beacon mounted 24 in. (600 mm) or less above, below, or to the side of the “SLOW” sign face. As an option, a Type B warning light may be used in lieu of the warning beacon.

A "WAIT ON STOP" sign shall be placed on the right hand side of the roadway at a point where drivers are expected to stop. The sign shall be 24 x 30 in. (600 x 750 mm) with a black legend and border on a white background. The letters shall be at least 6 in. (150 mm) high.

This device may include a gate arm or mast arm that descends to a horizontal position when the "STOP" sign is displayed and rises to a vertical position when the "SLOW" sign is displayed. When included, the end of the arm shall reach at least to the center of the lane being controlled. The arm shall have alternating red and white retroreflective stripes, on both sides, sloping downward at 45 degrees toward the side on which traffic will pass. The stripes shall be 6 in. (150 mm) in width and at least 2 in. (50 mm) in height.

Flagging Requirements. Flaggers and flagging requirements shall be according to Article 701.13 of the Standard Specifications and the following.

AFADs shall be placed at each end of the traffic control, where a flagger is shown on the plans. The flaggers shall be able to view the face of the AFAD and approaching traffic during operation.

To stop traffic, the "STOP" sign shall be displayed, the corresponding lights/beacon shall flash, and when included, the gate arm shall descend to a horizontal position. To permit traffic to move, the "SLOW" sign shall be displayed, the corresponding lights/beacon shall flash, and when included, the gate arm shall rise to a vertical position.

If used at night, the AFAD location shall be illuminated according to Section 701 of the Standard Specifications.

When not in use, AFADs will be considered nonoperating equipment and shall be stored according to Article 701.11 of the Standard Specifications.

Basis of Payment. This work will not be paid for separately but shall be considered as included in the cost of the various traffic control items included in the contract.

CONSTRUCTION AIR QUALITY – DIESEL RETROFIT (BDE)

Effective: June 1, 2010

The reduction of emissions of particulate matter (PM) for off-road equipment shall be accomplished by installing retrofit emission control devices. The term "equipment" refers to diesel fuel powered devices rated at 50 hp and above, to be used on the jobsite in excess of seven calendar days over the course of the construction period on the jobsite (including rental equipment).

Contractor and subcontractor diesel powered off-road equipment assigned to the contract shall be retrofitted using the phased in approach shown below. Equipment that is of a model year older than the year given for that equipment's respective horsepower range shall be retrofitted:

| Effective Dates | Horsepower Range | Model Year |
|----------------------------|------------------|------------|
| June 1, 2010 ^{1/} | 600-749 | 2002 |
| | 750 and up | 2006 |
| June 1, 2011 ^{2/} | 100-299 | 2003 |
| | 300-599 | 2001 |
| | 600-749 | 2002 |
| | 750 and up | 2006 |
| June 1, 2012 ^{2/} | 50-99 | 2004 |
| | 100-299 | 2003 |
| | 300-599 | 2001 |
| | 600-749 | 2002 |
| | 750 and up | 2006 |

- 1/ Effective dates apply to Contractor diesel powered off-road equipment assigned to the contract.
- 2/ Effective dates apply to Contractor and subcontractor diesel powered off-road equipment assigned to the contract.

The retrofit emission control devices shall achieve a minimum PM emission reduction of 50 percent and shall be:

- a) Included on the U.S. Environmental Protection Agency (USEPA) *Verified Retrofit Technology List* (<http://www.epa.gov/otaq/retrofit/verif-list.htm>), or verified by the California Air Resources Board (CARB) (<http://www.arb.ca.gov/diesel/verde/verdev.htm>); or
- b) Retrofitted with a non-verified diesel retrofit emission control device if verified retrofit emission control devices are not available for equipment proposed to be used on the project, and if the Contractor has obtained a performance certification from the retrofit device manufacturer that the emission control device provides a minimum PM emission reduction of 50 percent.

Note: Large cranes (Crawler mounted cranes) which are responsible for critical lift operations are exempt from installing retrofit emission control devices if such devices adversely affect equipment operation.

Diesel powered off-road equipment with engine ratings of 50 hp and above, which are unable to be retrofitted with verified emission control devices or if performance certifications are not available which will achieve a minimum 50 percent PM reduction, may be granted a waiver by the Department if documentation is provided showing good faith efforts were made by the Contractor to retrofit the equipment.

Construction shall not proceed until the Contractor submits a certified list of the diesel powered off-road equipment that will be used, and as necessary, retrofitted with emission control devices. The list(s) shall include (1) the equipment number, type, make, Contractor/rental company name; and (2) the emission control devices make, model, USEPA or CARB verification number, or performance certification from the retrofit device manufacturer. Equipment reported as fitted with emissions control devices shall be made available to the Engineer for visual inspection of the device installation, prior to being used on the jobsite.

The Contractor shall submit an updated list of retrofitted off-road construction equipment as retrofitted equipment changes or comes on to the jobsite. The addition or deletion of any diesel powered equipment shall be included on the updated list.

If any diesel powered off-road equipment is found to be in non-compliance with any portion of this special provision, the Engineer will issue the Contractor a diesel retrofit deficiency deduction.

Any costs associated with retrofitting any diesel powered off-road equipment with emission control devices shall be considered as included in the contract unit prices bid for the various items of work involved and no additional compensation will be allowed. The Contractor's compliance with this notice and any associated regulations shall not be grounds for a claim.

Diesel Retrofit Deficiency Deduction

When the Engineer determines that a diesel retrofit deficiency exists, a daily monetary deduction will be imposed for each calendar day or fraction thereof the deficiency continues to exist. The calendar day(s) will begin when the time period for correction is exceeded and end with the Engineer's written acceptance of the correction. The daily monetary deduction will be \$1,000.00 for each deficiency identified.

The deficiency will be based on lack of diesel retrofit emissions control.

If a Contractor accumulates three diesel retrofit deficiency deductions for the same piece of equipment in a contract period, the Contractor will be shutdown until the deficiency is corrected. Such a shutdown will not be grounds for any extension of the contract time, waiver of penalties, or be grounds for any claim.

CONSTRUCTION AIR QUALITY - DIESEL VEHICLE EMISSIONS CONTROL (BDE)

Effective: April 1, 2009

Revised: January 2, 2012

Diesel Vehicle Emissions Control. The reduction of construction air emissions shall be accomplished by using cleaner burning diesel fuel. The term "equipment" refers to any and all diesel fuel powered devices rated at 50 hp and above, to be used on the project site in excess of seven calendar days over the course of the construction period on the project site (including any "rental" equipment).

All equipment on the jobsite, with engine ratings of 50 hp and above, shall be required to: use Ultra Low Sulfur Diesel fuel (ULSD) exclusively (15 ppm sulfur content or less).

Diesel powered equipment in non-compliance will not be allowed to be used on the project site, and is also subject to a notice of non-compliance as outlined below.

The Contractor shall certify that only ULSD will be used in all jobsite equipment. The certification shall be presented to the Department prior to the commencement of the work.

If any diesel powered equipment is found to be in non-compliance with any portion of this specification, the Engineer will issue the Contractor a notice of non-compliance and identify an appropriate period of time, as outlined below under environmental deficiency deduction, in which to bring the equipment into compliance or remove it from the project site.

Any costs associated with bringing any diesel powered equipment into compliance with these diesel vehicle emissions controls shall be considered as included in the contract unit prices bid for the various items of work involved and no additional compensation will be allowed. The Contractor's compliance with this notice and any associated regulations shall also not be grounds for a claim.

Environmental Deficiency Deduction. When the Engineer is notified, or determines that an environmental control deficiency exists, he/she will notify the Contractor in writing, and direct the Contractor to correct the deficiency within a specified time period. The specified time-period, which begins upon Contractor notification, will be from 1/2 hour to 24 hours long, based on the urgency of the situation and the nature of the deficiency. The Engineer shall be the sole judge regarding the time period.

The deficiency will be based on lack of repair, maintenance and diesel vehicle emissions control.

If the Contractor fails to correct the deficiency within the specified time frame, a daily monetary deduction will be imposed for each calendar day or fraction thereof the deficiency continues to exist. The calendar day(s) will begin when the time period for correction is exceeded and end with the Engineer's written acceptance of the correction. The daily monetary deduction will be \$1,000.00 for each deficiency identified.

If a Contractor or subcontractor accumulates three environmental deficiency deductions in a contract period, the Contractor will be shutdown until the deficiency is corrected. Such a shutdown will not be grounds for any extension of contract time, waiver of penalties, or be grounds for any claim.

CONSTRUCTION AIR QUALITY - IDLING RESTRICTIONS (BDE)

Effective: April 1, 2009

Idling Restrictions. The Contractor shall establish truck-staging areas for all diesel powered vehicles that are waiting to load or unload material at the jobsite. Staging areas shall be located where the diesel emissions from the equipment will have a minimum impact on adjacent sensitive receptors. The Department will review the selection of staging areas, whether within or outside the existing highway right-of-way, to avoid locations near sensitive areas or populations to the extent possible. Sensitive receptors include, but are not limited to, hospitals, schools, residences, motels, hotels, daycare facilities, elderly housing and convalescent facilities. Diesel powered engines shall also be located as far away as possible from fresh air intakes, air conditioners, and windows. The Engineer will approve staging areas before implementation.

Diesel powered vehicle operators may not cause or allow the motor vehicle, when it is not in motion, to idle for more than a total of 10 minutes within any 60 minute period, except under any of the following circumstances:

- 1) The motor vehicle has a gross vehicle weight rating of less than 8000 lb (3630 kg).
- 2) The motor vehicle idles while forced to remain motionless because of on-highway traffic, an official traffic control device or signal, or at the direction of a law enforcement official.
- 3) The motor vehicle idles when operating defrosters, heaters, air conditioners, or other equipment solely to prevent a safety or health emergency.

- 4) A police, fire, ambulance, public safety, other emergency or law enforcement motor vehicle, or any motor vehicle used in an emergency capacity, idles while in an emergency or training mode and not for the convenience of the vehicle operator.
- 5) The primary propulsion engine idles for maintenance, servicing, repairing, or diagnostic purposes if idling is necessary for such activity.
- 6) A motor vehicle idles as part of a government inspection to verify that all equipment is in good working order, provided idling is required as part of the inspection.
- 7) When idling of the motor vehicle is required to operate auxiliary equipment to accomplish the intended use of the vehicle (such as loading, unloading, mixing, or processing cargo; controlling cargo temperature; construction operations, lumbering operations; oil or gas well servicing; or farming operations), provided that this exemption does not apply when the vehicle is idling solely for cabin comfort or to operate non-essential equipment such as air conditioning, heating, microwave ovens, or televisions.
- 8) When the motor vehicle idles due to mechanical difficulties over which the operator has no control.
- 9) The outdoor temperature is less than 32 °F (0 °C) or greater than 80 °F (26 °C).

When the outdoor temperature is greater than or equal to 32 °F (0 °C) or less than or equal to 80 °F (26 °C), a person who operates a motor vehicle operating on diesel fuel shall not cause or allow the motor vehicle to idle for a period greater than 30 minutes in any 60 minute period while waiting to weigh, load, or unload cargo or freight, unless the vehicle is in a line of vehicles that regularly and periodically moves forward.

The above requirements do not prohibit the operation of an auxiliary power unit or generator set as an alternative to idling the main engine of a motor vehicle operating on diesel fuel.

Environmental Deficiency Deduction. When the Engineer is notified, or determines that an environmental control deficiency exists based on non-compliance with the idling restrictions, he/she will notify the Contractor, and direct the Contractor to correct the deficiency.

If the Contractor fails to correct the deficiency a monetary deduction will be imposed. The monetary deduction will be \$1,000.00 for each deficiency identified.

DISADVANTAGED BUSINESS ENTERPRISE PARTICIPATION (BDE)

Effective: September 1, 2000

Revised: August 2, 2011

FEDERAL OBLIGATION. The Department of Transportation, as a recipient of federal financial assistance, is required to take all necessary and reasonable steps to ensure nondiscrimination in the award and administration of contracts. Consequently, the federal regulatory provisions of 49 CFR Part 26 apply to this contract concerning the utilization of disadvantaged business enterprises. For the purposes of this Special Provision, a disadvantaged business enterprise (DBE) means a business certified by the Department in accordance with the requirements of 49 CFR Part 26 and listed in the Illinois Unified Certification Program (IL UCP) DBE Directory.

STATE OBLIGATION. This Special Provision will also be used by the Department to satisfy the requirements of the Business Enterprise for Minorities, Females, and Persons with Disabilities Act, 30 ILCS 575. When this Special Provision is used to satisfy state law requirements on 100 percent state-funded contracts, the federal government has no involvement in such contracts (not a federal-aid contract) and no responsibility to oversee the implementation of this Special Provision by the Department on those contracts. DBE participation on 100 percent state-funded contracts will not be credited toward fulfilling the Department's annual overall DBE goal required by the US Department of Transportation to comply with the federal DBE program requirements.

CONTRACTOR ASSURANCE. The Contractor makes the following assurance and agrees to include the assurance in each subcontract that the Contractor signs with a subcontractor.

The Contractor, subrecipient, or subcontractor shall not discriminate on the basis of race, color, national origin, or sex in the performance of this contract. The Contractor shall carry out applicable requirements of 49 CFR Part 26 in the award and administration of contracts funded in whole or in part with federal or state funds. Failure by the Contractor to carry out these requirements is a material breach of this contract, which may result in the termination of this contract or such other remedy as the recipient deems appropriate.

OVERALL GOAL SET FOR THE DEPARTMENT. As a requirement of compliance with 49 CFR Part 26, the Department has set an overall goal for DBE participation in its federally assisted contracts. That goal applies to all federal-aid funds the Department will expend in its federally assisted contracts for the subject reporting fiscal year. The Department is required to make a good faith effort to achieve the overall goal. The dollar amount paid to all approved DBE companies performing work called for in this contract is eligible to be credited toward fulfillment of the Department's overall goal.

CONTRACT GOAL TO BE ACHIEVED BY THE CONTRACTOR. This contract includes a specific DBE utilization goal established by the Department. The goal has been included because the Department has determined that the work of this contract has subcontracting opportunities that may be suitable for performance by DBE companies. The determination is based on an assessment of the type of work, the location of the work, and the availability of DBE companies to do a part of the work. The assessment indicates that, in the absence of unlawful discrimination, and in an arena of fair and open competition, DBE companies can be expected to perform 20.00% of the work. This percentage is set as the DBE participation goal for this contract. Consequently, in addition to the other award criteria established for this contract, the Department will only award this contract to a bidder who makes a good faith effort to meet this goal of DBE participation in the performance of the work. A bidder makes a good faith effort for award consideration if either of the following is done in accordance with the procedures set for in this Special Provision:

- (a) The bidder documents that enough DBE participation has been obtained to meet the goal: or
- (b) The bidder documents that a good faith effort has been made to meet the goal, even though the effort did not succeed in obtaining enough DBE participation to meet the goal.

DBE LOCATOR REFERENCES. Bidders shall consult the IL UCP DBE Directory as a reference source for DBE-certified companies. In addition, the Department maintains a letting and item specific DBE locator information system whereby DBE companies can register their interest in providing quotes on particular bid items advertised for letting. Information concerning DBE companies willing to quote work for particular contracts may be obtained by contacting the Department's Bureau of Small Business Enterprises at telephone number (217)785-4611, or by visiting the Department's website at www.dot.il.gov.

BIDDING PROCEDURES. Compliance with this Special Provision is a material bidding requirement. The failure of the bidder to comply will render the bid not responsive.

- (a) The bidder shall submit a Disadvantaged Business Utilization Plan on Department forms SBE 2025 and 2026 with the bid.

- (b) The Utilization Plan shall indicate that the bidder either has obtained sufficient DBE participation commitments to meet the contract goal or has not obtained enough DBE participation commitments in spite of a good faith effort to meet the goal. The Utilization Plan shall further provide the name, telephone number, and telefax number of a responsible official of the bidder designated for purposes of notification of plan approval or disapproval under the procedures of this Special Provision.
- (c) The Utilization Plan shall include a DBE Participation Commitment Statement, Department form SBE 2025, for each DBE proposed for the performance of work to achieve the contract goal. For bidding purposes, submission of the completed SBE 2025 forms, signed by the DBEs and faxed to the bidder will be acceptable as long as the original is available and provided upon request. All elements of information indicated on the said form shall be provided, including but not limited to the following:
- (1) The names and addresses of DBE firms that will participate in the contract;
 - (2) A description, including pay item numbers, of the work each DBE will perform;
 - (3) The dollar amount of the participation of each DBE firm participating. The dollar amount of participation for identified work shall specifically state the quantity, unit price, and total subcontract price for the work to be completed by the DBE. If partial pay items are to be performed by the DBE, indicate the portion of each item, a unit price where appropriate and the subcontract price amount;
 - (4) DBE Participation Commitment Statements, form SBE 2025, signed by the bidder and each participating DBE firm documenting the commitment to use the DBE subcontractors whose participation is submitted to meet the contract goal;
 - (5) if the bidder is a joint venture comprised of DBE companies and non-DBE companies, the plan must also include a clear identification of the portion of the work to be performed by the DBE partner(s); and,
 - (6) If the contract goal is not met, evidence of good faith efforts.

GOOD FAITH EFFORT PROCEDURES. The contract will not be awarded until the Utilization Plan submitted by the apparent successful bidder is approved. All information submitted by the bidder must be complete, accurate and adequately document that enough DBE participation has been obtained or document that good faith efforts of the bidder, in the event enough DBE participation has not been obtained, before the Department will commit to the performance of the contract by the bidder. The Utilization Plan will be approved by the Department if the Utilization Plan documents sufficient commercially useful DBE work performance to meet the contract goal or the bidder submits sufficient documentation of a good faith effort to meet the contract goal pursuant to 49 CFR Part 26, Appendix A. The Utilization Plan will not be approved by the Department if the Utilization Plan does not document sufficient DBE participation to meet the contract goal unless the apparent successful bidder documented in the Utilization Plan that it made a good faith effort to meet the goal. This means that the bidder must show that all necessary and reasonable steps were taken to achieve the contract goal. Necessary and reasonable steps are those which, by their scope, intensity and appropriateness to the objective, could reasonably be expected to obtain sufficient DBE participation, even if they were not successful. The Department will consider the quality, quantity, and intensity of the kinds of efforts that the bidder has made. Mere *pro forma* efforts, in other words, efforts done as a matter of form, are not good faith efforts; rather, the bidder is expected to have taken genuine efforts that would be reasonably expected of a bidder actively and aggressively trying to obtain DBE participation sufficient to meet the contract goal.

- (a) The following is a list of types of action that the Department will consider as part of the evaluation of the bidder's good faith efforts to obtain participation. These listed factors are not intended to be a mandatory checklist and are not intended to be exhaustive. Other factors or efforts brought to the attention of the Department may be relevant in appropriate cases, and will be considered by the Department.
- (1) Soliciting through all reasonable and available means (e.g. attendance at pre-bid meetings, advertising and/or written notices) the interest of all certified DBE companies that have the capability to perform the work of the contract. The bidder must solicit this interest within sufficient time to allow the DBE companies to respond to the solicitation. The bidder must determine with certainty if the DBE companies are interested by taking appropriate steps to follow up initial solicitations.
 - (2) Selecting portions of the work to be performed by DBE companies in order to increase the likelihood that the DBE goals will be achieved. This includes, where appropriate, breaking out contract work items into economically feasible units to facilitate DBE participation, even when the prime Contractor might otherwise prefer to perform these work items with its own forces.
 - (3) Providing interested DBE companies with adequate information about the plans, specifications, and requirements of the contract in a timely manner to assist them in responding to a solicitation.
 - (4) a. Negotiating in good faith with interested DBE companies. It is the bidder's responsibility to make a portion of the work available to DBE subcontractors and suppliers and to select those portions of the work or material needs consistent with the available DBE subcontractors and suppliers, so as to facilitate DBE participation. Evidence of such negotiation includes the names, addresses, and telephone numbers of DBE companies that were considered; a description of the information provided regarding the plans and specifications for the work selected for subcontracting; and evidence as to why additional agreements could not be reached for DBE companies to perform the work.
b. A bidder using good business judgment would consider a number of factors in negotiating with subcontractors, including DBE subcontractors, and would take a firm's price and capabilities as well as contract goals into consideration. However, the fact that there may be some additional costs involved in finding and using DBE companies is not in itself sufficient reason for a bidder's failure to meet the contract DBE goal, as long as such costs are reasonable. Also the ability or desire of a bidder to perform the work of a contract with its own organization does not relieve the bidder of the responsibility to make good faith efforts. Bidders are not, however, required to accept higher quotes from DBE companies if the price difference is excessive or unreasonable.
 - (5) Not rejecting DBE companies as being unqualified without sound reasons based on a thorough investigation of their capabilities. The bidder's standing within its industry, membership in specific groups, organizations, or associations and political or social affiliations (for example union vs. non-union employee status) are not legitimate causes for the rejection or non-solicitation of bids in the bidder's efforts to meet the project goal.
 - (6) Making efforts to assist interested DBE companies in obtaining bonding, lines of credit, or insurance as required by the recipient or Contractor.
 - (7) Making efforts to assist interested DBE companies in obtaining necessary equipment, supplies, materials, or related assistance or services.
 - (8) Effectively using the services of available minority/women community organizations; minority/women contractors' groups; local, state, and federal minority/women business assistance offices; and other organizations as allowed on a case-by-case basis to provide assistance in the recruitment and placement of DBE companies.

- (b) If the Department determines that the apparent successful bidder has made a good faith effort to secure the work commitment of DBE companies to meet the contract goal, the Department will award the contract provided that it is otherwise eligible for award. If the Department determines that the bidder has failed to meet the requirements of this Special Provision or that a good faith effort has not been made, the Department will notify the responsible company official designated in the Utilization Plan that the bid is not responsive. The notification shall include a statement of reasons for the determination.
- (c) The bidder may request administrative reconsideration of a determination adverse to the bidder within the five working days after the receipt of the notification date of the determination by delivering the request to the Department of Transportation, Bureau of Small Business Enterprises, Contract Compliance Section, 2300 South Dirksen Parkway, Room 319, Springfield, Illinois 62764 (Telefax: (217)785-1524). Deposit of the request in the United States mail on or before the fifth business day shall not be deemed delivery. The determination shall become final if a request is not made and delivered. A request may provide additional written documentation and/or argument concerning the issues raised in the determination statement of reasons, provided the documentation and arguments address efforts made prior to submitting the bid. The request will be forwarded to the Department's Reconsideration Officer. The Reconsideration Officer will extend an opportunity to the bidder to meet in person in order to consider all issues of documentation and whether the bidder made a good faith effort to meet the goal. After the review by the Reconsideration Officer, the bidder will be sent a written decision within ten working days after receipt of the request for consideration, explaining the basis for finding that the bidder did or did not meet the goal or make adequate good faith efforts to do so. A final decision by the Reconsideration Officer that a good faith effort was made shall approve the Utilization Plan submitted by the bidder and shall clear the contract for award. A final decision that a good faith effort was not made shall render the bid not responsive.

CALCULATING DBE PARTICIPATION. The Utilization Plan values represent work anticipated to be performed and paid for upon satisfactory completion. The Department is only able to count toward the achievement of the overall goal and the contract goal the value of payments made for the work actually performed by DBE companies. In addition, a DBE must perform a commercially useful function on the contract to be counted. A commercially useful function is generally performed when the DBE is responsible for the work and is carrying out its responsibilities by actually performing, managing, and supervising the work involved. The Department and Contractor are governed by the provisions of 49 CFR Part 26.55(c) on questions of commercially useful functions as it affects the work. Specific counting guidelines are provided in 49 CFR Part 26.55, the provisions of which govern over the summary contained herein.

- (a) DBE as the Contractor: 100 percent goal credit for that portion of the work performed by the DBE's own forces, including the cost of materials and supplies. Work that a DBE subcontracts to a non-DBE does not count toward the DBE goals.
- (b) DBE as a joint venture Contractor: 100 percent goal credit for that portion of the total dollar value of the contract equal to the distinct, clearly defined portion of the work performed by the DBE's own forces.
- (c) DBE as a subcontractor: 100 percent goal credit for the work of the subcontract performed by the DBE's own forces, including the cost of materials and supplies, excluding the purchase of materials and supplies or the lease of equipment by the DBE subcontractor from the prime Contractor or its affiliates. Work that a DBE subcontractor in turn subcontracts to a non-DBE does not count toward the DBE goal.

- (d) DBE as a trucker: 100 percent goal credit for trucking participation provided the DBE is responsible for the management and supervision of the entire trucking operation for which it is responsible. At least one truck owned, operated, licensed, and insured by the DBE must be used on the contract. Credit will be given for the following:
- (1) The DBE may lease trucks from another DBE firm, including an owner-operator who is certified as a DBE. The DBE who leases trucks from another DBE receives credit for the total value of the transportation services the lessee DBE provides on the contract.
 - (2) The DBE may also lease trucks from a non-DBE firm, including from an owner-operator. The DBE who leases trucks from a non-DBE is entitled to credit only for the fee or commission is receives as a result of the lease arrangement.
- (e) DBE as a material supplier:
- (1) 60 percent goal credit for the cost of the materials or supplies purchased from a DBE regular dealer.
 - (2) 100 percent goal credit for the cost of materials of supplies obtained from a DBE manufacturer.
 - (3) 100 percent credit for the value of reasonable fees and commissions for the procurement of materials and supplies if not a regular dealer or manufacturer.

CONTRACT COMPLIANCE. Compliance with this Special Provision is an essential part of the contract. The Department is prohibited by federal regulations from crediting the participation of a DBE included in the Utilization Plan toward either the contract goal or the Department's overall goal until the amount to be applied toward the goals has been paid to the DBE. The following administrative procedures and remedies govern the compliance by the Contractor with the contractual obligations established by the Utilization Plan. After approval of the Utilization Plan and award of the contract, the Utilization Plan and individual DBE Participation Statements become part of the contract. If the Contractor did not succeed in obtaining enough DBE participation to achieve the advertised contract goal, and the Utilization Plan was approved and contract awarded based upon a determination of good faith, the total dollar value of DBE work calculated in the approved Utilization Plan as a percentage of the awarded contract value shall become the amended contract goal. All work indicated for performance by an approved DBE shall be performed, managed, and supervised by the DBE executing the Participation Statement.

- (a) **NO AMENDMENT.** No amendment to the Utilization Plan may be made without prior written approval from the Department's Bureau of Small Business Enterprises. All requests for amendment to the Utilization Plan shall be submitted to the Department of Transportation, Bureau of Small Business Enterprises, Contract Compliance Section, 2300 South Dirksen Parkway, Room 319, Springfield, Illinois 62764. Telephone number (217)785-4611. Telefax number (217)785-1524.
- (b) **TERMINATION OR REPLACEMENT.** The Contractor shall not terminate or replace a DBE listed on the approved Utilization Plan, or perform with other forces work designated for a listed DBE except as provided in the Special Provision.
- (c) **CHANGES TO WORK.** Any deviation from the DBE condition-of-award or contract plans, specifications, or special provisions must be approved, in writing, by the Department as provided elsewhere in the Contract. The Contractor shall notify affected DBEs in writing of any changes in the scope of work which result in a reduction in the dollar amount condition-of-award to the contract. Where the revision includes work committed to a new DBE subcontractor, not previously involved in the project, then a Request for Approval of Subcontractor, Department form BC 260A, must be signed and submitted. If the commitment of work is in the form of additional tasks assigned to an

existing subcontract, than a new Request for Approval of Subcontractor shall not be required. However, the Contractor must document efforts to assure that the existing DBE subcontractor is capable of performing the additional work and has agreed in writing to the change.

- (d) ALTERNATIVE WORK METHODS. In addition to the above requirements for reductions in the condition of award, additional requirements apply to the two cases of Contractor-initiated work substitution proposals. Where the contract allows alternate work methods which serve to delete or create underruns in condition of award DBE work, and the Contractor selects that alternate method or, where the Contractor proposes a substitute work method or material that serves to diminish or delete work committed to a DBE and replace it with other work, then the Contractor must demonstrate one of the following:
- (1) That the replacement work will be performed by the same DBE (as long as the DBE is certified in the respective item of work) in a modification of the condition of award; or
 - (2) That the DBE is aware that its work will be deleted or will experience underruns and has agreed in writing to the change. If this occurs, the Contractor shall substitute other work of equivalent value to a certified DBE or provide documentation of good faith efforts to do so; or
 - (3) That the DBE is not capable of performing the replacement work or has declined to perform the work at a reasonable competitive price. If this occurs, the Contractor shall substitute other work of equivalent value to a certified DBE or provide documentation of good faith efforts to do so.
- (e) TERMINATION AND REPLACEMENT PROCEDURES. The Contractor shall not terminate or replace a DBE subcontractor listed in the approved Utilization Plan without prior written consent. This includes, but is not limited to, instances in which the Contractor seeks to perform work originally designated for a DBE subcontractor with its own forces or those of an affiliate, a non-DBE firm, or with another DBE firm. Written consent will be granted only if the Bureau of Small Business Enterprises agrees, for reasons stated in its concurrence document, that the Contractor has good cause to terminate or replace the DBE firm. Before transmitting to the Bureau of Small Business Enterprises any request to terminate and/or substitute a DBE subcontractor, the Contractor shall give notice in writing to the DBE subcontractor, with a copy to the Bureau, of its intent to request to terminate and/or substitute, and the reason for the request. The Contractor shall give the DBE five days to respond to the Contractor's notice. The DBE so notified shall advise the Bureau and the Contractor of the reasons, if any, why it objects to the proposed termination of its subcontract and why the Bureau should not approve the Contractor's action. If required in a particular case as a matter of public necessity, the Bureau may provide a response period shorter than five days.

For purposes of this paragraph, good cause includes the following circumstances:

- (1) The listed DBE subcontractor fails or refuses to execute a written contract;
- (2) The listed DBE subcontractor fails or refuses to perform the work of its subcontract in a way consistent with normal industry standards. Provided, however, that good cause does not exist if the failure or refusal of the DBE subcontractor to perform its work on the subcontract results from the bad faith or discriminatory action of the prime contractor;
- (3) The listed DBE subcontractor fails or refuses to meet the prime Contractor's reasonable, nondiscriminatory bond requirements;

- (4) The listed DBE subcontractor becomes bankrupt, insolvent, or exhibits credit unworthiness;
- (5) The listed DBE subcontractor is ineligible to work on public works projects because of suspension and debarment proceedings pursuant 2 CFR Parts 180, 215 and 1,200 or applicable state law.
- (6) You have determined that the listed DBE subcontractor is not a responsible contractor;
- (7) The listed DBE subcontractor voluntarily withdraws from the projects and provides to you written notice of its withdrawal;
- (8) The listed DBE is ineligible to receive DBE credit for the type of work required;
- (9) A DBE owner dies or becomes disabled with the result that the listed DBE contractor is unable to complete its work on the contract;
- (10) Other documented good cause that compels the termination of the DBE subcontractor. Provided, that good cause does not exist if the prime Contractor seeks to terminate a DBE it relied upon to obtain the contract so that the prime Contractor can self-perform the work for which the DBE contractor was engaged or so that the prime Contractor can substitute another DBE or non-DBE contractor after contract award.

When a DBE is terminated, or fails to complete its work on the Contract for any reason the Contractor shall make a good faith effort to find another DBE to substitute for the original DBE to perform at least the same amount of work under the contract as the terminated DBE to the extent needed to meet the established Contract goal.

- (f) PAYMENT RECORDS. The Contractor shall maintain a record of payments for work performed to the DBE participants. The records shall be made available to the Department for inspection upon request. After the performance of the final item of work or delivery of material by a DBE and final payment therefore to the DBE by the Contractor, but not later than thirty calendar days after payment has been made by the Department to the Contractor for such work or material, the Contractor shall submit a DBE Payment Agreement on Department form SBE 2115 to the Regional Engineer. If full and final payment has not been made to the DBE, the DBE Payment Agreement shall indicate whether a disagreement as to the payment required exists between the Contractor and the DBE or if the Contractor believes that the work has not been satisfactorily completed. If the Contractor does not have the full amount of work indicated in the Utilization Plan performed by the BDE companies indicated in the Utilization Plan and after good faith efforts are reviewed, the Department may deduct from contract payments to the Contractor the amount of the goal not achieved as liquidated and ascertained damages. The Contractor may request an administrative reconsideration of any amount deducted as damages pursuant to subsection (h) of this part.
- (g) ENFORCEMENT. The Department reserves the right to withhold payment to the Contractor to enforce the provisions of this Special Provision. Final payment shall not be made on the contract until such time as the Contractor submits sufficient documentation demonstrating achievement of the goal in accordance with this Special Provision or after liquidated damages have been determined and collected.
- (h) RECONSIDERATION. Notwithstanding any other provision of the contract, including but not limited to Article 109.09 of the Standard Specifications, the Contractor may request administrative reconsideration of a decision to deduct the amount of the goal not achieved as liquidated damages. A request to reconsider shall be delivered to the

Contract Compliance Section and shall be handled and considered in the same manner as set forth in paragraph (c) of "Good Faith Effort Procedures" of this Special Provision, except a final decision that a good faith effort was not made during contract performance to achieve the goal agreed to in the Utilization Plan shall be the final administrative decision of the Department.

ERRATA FOR THE 2012 STANDARD SPECIFICATIONS (BDE)

Effective: April 1, 2012

- Page 337 Article 505.04. Revise the subparagraph "(i) Match Making." to read "(i) Match Marking."
- Page 360 Article 506.07. In the first line of the second paragraph change "AASHTO/AWS D1.5/D1.5:" to "AASHTO/AWS D1.5M/D1.5:".
- Page 361 Article 506.08. In the third line of the sixth paragraph change "506.08(a)" to "506.08(b)".
- Page 531 Article 609.07. In the first paragraph delete "TYPE B, C, or D INLET BOX STANDARD 609001 or".
- Page 609 Article 703.05. In the first line of the second paragraph delete "or Type II".
- Page 989 Article 1083.02(a). In the seventh line of the first paragraph change "Table 14.7.5.2-2" to "Table 14.7.5.2-1".

FLAGGER AT SIDE ROADS AND ENTRANCES (BDE)

Effective: April 1, 2009

Revise the second paragraph of Article 701.13(a) of the Standard Specifications to read:

"The Engineer will determine when a side road or entrance shall be closed to traffic. A flagger will be required at each side road or entrance remaining open to traffic within the operation where two-way traffic is maintained on one lane of pavement. The flagger shall be positioned as shown on the plans or as directed by the Engineer."

Revise the first and second paragraph of Article 701.20(i) of the Standard Specifications to read:

"Signs, barricades, or other traffic control devices required by the Engineer over and above those specified will be paid for according to Article 109.04. All flaggers required at side roads and entrances remaining open to traffic including those that are shown on the Highway Standards and/or additional barricades required by the Engineer to close side roads and entrances will be paid for according to Article 109.04."

HIGH TENSION CABLE MEDIAN BARRIER (BDE)

Effective: January 1, 2007

Revised: April 1, 2009

Description. This work shall consist of furnishing and installing a high tension cable (HTC) median barrier with terminals/end anchorages.

Materials. Materials shall be according to the following.

| Item | Article/Section |
|---|-----------------|
| (a) Reinforcement Bars | 1006.10(a) |
| (b) Portland Cement Concrete (Note 1) | 1020 |
| (c) Wire Rope (Cable) and Fittings (Note 2) | |

Note 1. The portland cement concrete shall be Class SI.

Note 2. The wire rope (cable) shall be according to AASHTO M 30, Type 1 with Class A coating, of the diameter shown in the manufacturer's specifications. Additionally, the wire rope shall be prestretched and shall have a breaking strength of 39,285 lbs (175 kN) for 3/4 in. (19 mm) wire rope (individual wire strength equivalent to 174,000 psi (1200 N/mm)) and the prestretched wire rope shall have a minimum modulus of elasticity of 11,805,000 psi (8300 kg/mm).

The barrier shall be tested and accepted under the National Cooperative Highway Research Program (NCHRP) Report 350 for the required test level and be on the Department's approved list. Barriers installed on front slope grades of 1:6 or flatter shall be Test Level 4. Barriers installed on front slope grades steeper than 1:6 but 1:4 or flatter shall be Test Level 3.

The barrier shall include four longitudinal cables, each separated vertically from adjacent cable(s) by a minimum of 4 in. (100 mm), and according to the specific acceptance document issued by FHWA. Each cable shall run to a point of anchorage at the terminal without connection to any other cable. The maximum spacing for line posts in the cable barrier system shall be no more than shown in the specific document issued by FHWA, or 15 ft (4.6 m), whichever is less.

The terminals/end anchorages shall be tested and accepted under NCHRP Report 350 Test Level 3 and be on the Department's approved list.

Equipment. Equipment shall be according to the barrier manufacturer's specifications.

Construction Requirements

General. The HTC median barrier shall be constructed to the lines and grades shown on the plans and according to the manufacturer's specifications except as modified by the contracts documents.

Line Post Foundations. Line posts for the HTC median barrier shall be placed in concrete socket foundations. The minimum depth of the foundations shall be as shown on the plans. The minimum diameter for the foundations shall be 12 in. (300 mm) and the tops of the foundations shall be crowned 1/2 in. (13 mm).

When the barrier is to be placed within paved shoulders or mow strips, the paved area(s) shall be constructed first and the concrete foundations placed in cored or formed holes.

End Anchorages. The Contractor shall submit shop drawings and calculations to the Engineer prepared and sealed by an Illinois Licensed Structural Engineer detailing the required end anchorage foundation system at each location. The system shall utilize drilled shaft foundation of a diameter, depth, reinforcement, and cable connection determined by the supplier. The design shall utilize Broms method utilizing a minimum factor of safety of 1.5. The design loadings shall consist of the theoretical cumulative cable tension expected for temperature fluctuations to -10 °F (-23 °C). The dynamic vehicle impact loading shall not be added to the cable temperature loading for the analysis. The foundation soils shall be assumed to be

submerged granular material with a friction angle of 30 degrees or clay soils with a cohesive intercept of 1.0 kip/sq ft (48 kPa), unless site specific soil parameters are specified.

Tensioning. Prior to acceptance of the work, the tension of the HTC median barrier shall be checked, and adjusted as necessary, according to the manufacturer's temperature/tension chart or relationship.

Hands-On Demonstration. When included in the contract, a hands-on demonstration(s) of maintenance/repair procedures, recommendations and discussion of vehicle recovery, and provisions for emergency openings in the barrier shall be conducted. These demonstrations shall be for emergency responders, maintenance personnel, and others invited by the Engineer and shall either be conducted either at the job-site or at another agreed to meeting facility. Up to 30 attendees shall be accommodated at each demonstration.

Method of Measurement. HTC median barrier will be measured for payment in feet (meters) along the top cable between terminals. Terminals shall be defined as the end anchorages and other components from the extreme ends of a run to a point 50 ft (15.2 m) into the run. This definition of the terminal applies regardless of the length of need point, transitions from anchorage to full height cable, or other features that may vary between systems.

Basis of Payment. This work will be paid for at the contract unit price per foot (meter) for HIGH TENSION CABLE MEDIAN BARRIER.

The terminals/end anchorages and demonstrations will be paid for at the contract per each for HIGH TENSION CABLE MEDIAN BARRIER TERMINALS and HIGH TENSION CABLE MEDIAN BARRIER DEMONSTRATION respectively.

IMPACT ATTENUATORS (BDE)

Effective: November 1, 2003

Revised: January 1, 2012

Add the following to the Standard Specifications:

"SECTION 643. IMPACT ATTENUATORS

643.01 Description. This work shall consist of furnishing and installing impact attenuators.

643.02 Materials. Materials shall be according to the impact attenuator manufacturer's specifications and the following.

| Item | Article/Section |
|--|---------------------------|
| (a) Fine Aggregate (Note 1)..... | 1003.01 |
| (b) Steel Posts, Structural Shapes, and Plates | 1006.04 |
| (c) Rail Elements, End Section Plates, and Splice Plates | 1006.25 |
| (d) Bolts, Nuts, Washers and Hardware | 1006.25 |
| (e) Hollow Structural Tubing | 1006.27(b) |
| (f) Wood Posts and Wood Blockouts | 1007.01, 1007.02, 1007.06 |
| (g) Preservative Treatment..... | 1007.12 |

Note 1. Fine aggregate shall be FA 1 or FA 2, Class A quality. The sand shall be unbagged and shall have a maximum moisture content of five percent.

CONSTRUCTION REQUIREMENTS

643.03 General. Impact attenuators shall meet the testing criteria contained in either NCHRP Report 350 or MASH and shall be on the Department's approved list. Fully redirective and partially redirective attenuators shall be designed for bi-directional impacts.

643.04 Installation. Impact attenuators shall be installed according to the manufacturer's specifications and include all necessary transitions between the impact attenuator and the item to which it is attached. Regrading of slopes or approaches for the installation shall be as shown on the plans.

The design for sand module impact attenuators (orientation and number of modules, sand weights, etc.) shall be as shown on the plans. Bases for sand module impact attenuators will be required. The bases shall be constructed of either portland cement concrete or hot-mix asphalt (HMA). Portland cement concrete bases shall be 6 in. (150 mm) thick and be according to the applicable requirements of Section 424. HMA bases shall be 8 in. (200 mm) thick and be according to the applicable requirements of Section 408. The surface of the base shall be slightly sloped or crowned to facilitate drainage. The perimeter of each module and the specified weight (mass) of sand in each module shall be painted on the surface of the base.

Bases for impact attenuators, other than sand modules, shall be installed when required by the manufacturer. The bases shall be constructed according to the manufacturer's specifications, on a prepared subgrade. The surface of the base shall be slightly sloped or crowned to facilitate drainage.

643.05 Method of Measurement. This work will be measured for payment as each, where each is defined as one complete installation.

Contract quantities for sand module attenuator bases may be accepted according to Article 202.07(a). When measured, sand module attenuator bases will be measured in place and the dimensions used to calculate square yards (square meters) will not exceed those as shown on the plans.

643.06 Basis of Payment. This work will be paid for at the contract unit price per each for IMPACT ATTENUATORS (FULLY REDIRECTIVE, NARROW); IMPACT ATTENUATORS (FULLY REDIRECTIVE, WIDE); IMPACT ATTENUATORS (FULLY REDIRECTIVE, RESETTABLE); IMPACT ATTENUATORS (SEVERE USE, NARROW); IMPACT ATTENUATORS (SEVERE USE, WIDE); IMPACT ATTENUATORS (PARTIALLY REDIRECTIVE); or IMPACT ATTENUATORS (NON-REDIRECTIVE), of the test level specified.

Sand module impact attenuator bases will be paid for at the contract unit price per square yard (square meter) for ATTENUATOR BASE.

Regrading of slopes or approaches will be paid for according to Section 202 and/or Section 204 of the Standard Specifications."

PAYMENTS TO SUBCONTRACTORS (BDE)

Effective: June 1, 2000

Revised: January 1, 2006

Federal regulations found at 49 CFR §26.29 mandate the Department to establish a contract clause to require Contractors to pay subcontractors for satisfactory performance of their subcontracts and to set the time for such payments.

State law also addresses the timing of payments to be made to subcontractors and material suppliers. Section 7 of the Prompt Payment Act, 30 ILCS 540/7, requires that when a Contractor receives any payment from the Department, the Contractor shall make corresponding, proportional payments to each subcontractor and material supplier performing work or supplying material within 15 calendar days after receipt of the Department payment. Section 7 of the Act further provides that interest in the amount of two percent per month, in addition to the payment due, shall be paid to any subcontractor or material supplier by the Contractor if the payment required by the Act is withheld or delayed without reasonable cause. The Act also provides that the time for payment required and the calculation of any interest due applies to transactions between subcontractors and lower-tier subcontractors and material suppliers throughout the contracting chain.

This Special Provision establishes the required federal contract clause, and adopts the 15 calendar day requirement of the State Prompt Payment Act for purposes of compliance with the federal regulation regarding payments to subcontractors. This contract is subject to the following payment obligations.

When progress payments are made to the Contractor according to Article 109.07 of the Standard Specifications, the Contractor shall make a corresponding payment to each subcontractor and material supplier in proportion to the work satisfactorily completed by each subcontractor and for the material supplied to perform any work of the contract. The proportionate amount of partial payment due to each subcontractor and material supplier throughout the contracting chain shall be determined by the quantities measured or otherwise determined as eligible for payment by the Department and included in the progress payment to the Contractor. Subcontractors and material suppliers shall be paid by the Contractor within 15 calendar days after the receipt of payment from the Department. The Contractor shall not hold retainage from the subcontractors. These obligations shall also apply to any payments made by subcontractors and material suppliers to their subcontractors and material suppliers; and to all payments made to lower tier subcontractors and material suppliers throughout the contracting chain. Any payment or portion of a payment subject to this provision may only be withheld from the subcontractor or material supplier to whom it is due for reasonable cause.

This Special Provision does not create any rights in favor of any subcontractor or material supplier against the State or authorize any cause of action against the State on account of any payment, nonpayment, delayed payment, or interest claimed by application of the State Prompt Payment Act. The Department will not approve any delay or postponement of the 15 day requirement except for reasonable cause shown after notice and hearing pursuant to Section 7(b) of the State Prompt Payment Act. State law creates other and additional remedies available to any subcontractor or material supplier, regardless of tier, who has not been paid for work properly performed or material furnished. These remedies are a lien against public funds set forth in Section 23(c) of the Mechanics Lien Act, 770 ILCS 60/23(c), and a recovery on the Contractor's payment bond according to the Public Construction Bond Act, 30 ILCS 550.

PAYROLLS AND PAYROLL RECORDS (BDE)

Effective: January 2, 2012

Revise Section IV of Check Sheet #5 of the Recurring Special Provisions to read:

“IV.COMPLIANCE WITH THE PREVAILING WAGE ACT

1. **Prevailing Wages.** All wages paid by the Contractor and each subcontractor shall be in compliance with The Prevailing Wage Act (820 ILCS 130), as amended, except where a prevailing wage violates a federal law, order, or ruling, the rate conforming to the federal law, order, or ruling shall govern. The Contractor shall be responsible to notify each subcontractor of the wage rates set forth in this contract and any revisions thereto. If the Department of Labor revises the wage rates, the Contractor will not be allowed additional compensation on account of said revisions.
2. **Payroll Records.** The Contractor and each subcontractor shall make and keep, for a period of three years from the later of the date of final payment under the contract or completion of the contract, records of the wages paid to his/her workers. The payroll records shall include each worker's name, address, telephone number, social security number, classification, rate of pay, number of hours worked each day, starting and ending times of work each day, total hours worked each week, itemized deductions made, and actual wages paid. Upon seven business days' notice, these records shall be available at a location within the State, during reasonable hours, for inspection by the Department; the Department of Labor; and Federal, State or local law enforcement agencies and prosecutors.
3. **Submission of Payroll Records.** The Contractor and each subcontractor shall submit payroll records to the Engineer each week from the start to the completion of their respective work, except that full social security numbers and home addresses shall not be included on weekly transmittals. Instead the payrolls shall include an identification number for each employee (e.g., the last four digits of the employee's social security number). In addition, starting and ending times of work each day may be omitted from the payroll records submitted to the Engineer. The submittals shall be on the Department's form SBE 48, or an approved facsimile. When there has been no activity during a work week, a payroll record shall still be submitted with the appropriate box ("No Work", "Suspended", or "Complete") checked on the form.

Each submittal shall be accompanied by a statement signed by the Contractor or subcontractor, or an officer, employee or officer thereof, which avers that: (i) he or she has examined the records and such records are true and accurate; (ii) the hourly rate paid to each worker is not less than the general prevailing rate of hourly wages required by the Act; and (iii) the Contractor or subcontractor is aware that filing a payroll record that he/she knows to be false is a Class A misdemeanor.

4. **Employee Interviews.** The Contractor and each subcontractor shall permit his/her employees to be interviewed on the job, during working hours, by compliance investigators of the Department or the Department of Labor."

SUBCONTRACTOR MOBILIZATION PAYMENTS (BDE)

Effective: April 2, 2005

Revised: April 1, 2011

To account for the preparatory work and operations necessary for the movement of subcontractor personnel, equipment, supplies, and incidentals to the project site and for all other work or operations that must be performed or costs incurred when beginning work approved for subcontracting according to Article 108.01 of the Standard Specifications, the Contractor shall make a mobilization payment to each subcontractor.

This mobilization payment shall be made at least 14 days prior to the subcontractor starting work. The amount paid shall be equal to 3 percent of the amount of the subcontract reported on form BC 260A submitted for the approval of the subcontractor's work.

The mobilization payment to the subcontractor is an advance payment of the reported amount of the subcontract and is not a payment in addition to the amount of the subcontract; therefore, the amount of the advance payment will be deducted from future progress payments.

This provision shall be incorporated directly or by reference into each subcontract approved by the Department.

TRAFFIC CONTROL DEFICIENCY DEDUCTION (BDE)

Effective: August 1, 2011

Revise the third sentence of the third paragraph of Article 105.03(b) of the Standard Specifications to read:

“The daily monetary deduction will be \$2,500.”

UTILITY COORDINATION AND CONFLICTS (BDE)

Effective: April 1, 2011

Revised: January 1, 2012

Revise Article 105.07 of the Standard Specifications to read:

“**105.07 Cooperation with Utilities.** The Department reserves the right at any time to allow work by utilities on or near the work covered by the contract. The Contractor shall conduct his/her work so as not to interfere with or hinder the progress or completion of the work being performed by utilities. The Contractor shall also arrange the work and shall place and dispose of the materials being used so as not to interfere with the operations of utility work in the area.

The Contractor shall cooperate with the owners of utilities in their removal and rearrangement operations so work may progress in a reasonable manner, duplication or rearrangement of work may be reduced to a minimum, and services rendered by those parties will not be unnecessarily interrupted.

The Contractor shall coordinate with any planned utility adjustment or new installation and the Contractor shall take all precautions to prevent disturbance or damage to utility facilities. Any failure on the part of the utility owner, or their representative, to proceed with any planned utility adjustment or new installation shall be reported promptly by the Contractor to the Engineer.”

Revise the first sentence of the last paragraph of Article 107.19 of the Standard Specifications to read:

“When the Contractor encounters unexpected regulated substances due to the presence of utilities in unanticipated locations, the provisions of Article 107.40 shall apply; otherwise, if the Engineer does not direct a resumption of operations, the provisions of Article 108.07 shall apply.”

Revise Article 107.31 of the Standard Specification to read:

“107.31 Reserved.”

Add the following four Articles to Section 107 of the Standard Specifications:

“107.37 Locations of Utilities within the Project Limits. All known utilities existing within the limits of construction are either indicated on the plans or visible above ground. For the purpose of this Article, the limits of proposed construction are defined as follows:

(a) Limits of Proposed Construction for Utilities Paralleling the Roadway.

- (1) The horizontal limits shall be a vertical plane, outside of, parallel to, and 2 ft (600 mm) distant at right angles from the plan or revised slope limits.

In cases where the limits of excavation for structures are not shown on the plans, the horizontal limits shall be a vertical plane 4 ft (1.2 m) outside the edges of structure footings or the structure where no footings are required.

- (2) The upper vertical limits shall be the regulations governing the roadbed clearance for the specific utility involved.
- (3) The lower vertical limits shall be either the top of the utility at the depth below the proposed grade as prescribed by the governing agency or the limits of excavation, whichever is less.

(b) Limits of Proposed Construction for Utilities Crossing the Roadway in a Generally Transverse Direction.

- (1) Utilities crossing excavations for structures that are normally made by trenching such as sewers, underdrains, etc. and all minor structures such as manholes, inlets, foundations for signs, foundations for traffic signals, etc., the limits shall be the space to be occupied by the proposed permanent construction, unless otherwise required by the regulations governing the specific utility involved.
- (2) For utilities crossing the proposed site of major structures such as bridges, sign trusses, etc., the limits shall be as defined above for utilities extending in the same general direction as the roadway.

It is understood and agreed that the Contractor has considered in the bid all of the permanent and temporary utilities in their present and/or adjusted positions as indicated in the contract. It is further understood the actual location of the utilities may be located anywhere within the tolerances provided in 220 ILCS 50/2.8 or Administrative Code Title 92 Part 530.40(c), and the proximity of some utilities to construction may require extraordinary measures by the Contractor to protect those utilities.

No additional compensation will be allowed for any delays, inconveniences, or damages sustained by the Contractor due to the presence of or any claimed interference from known utility facilities or any adjustment of them, except as specifically provided in the contract.

107.38 Adjustments of Utilities within the Project Limits. The adjustment of utilities consists of the relocation, removal, replacement, rearrangements, reconstruction, improvement, disconnection, connection, shifting, new installation, or altering of an existing utility facility in any manner.

Utilities which are to be adjusted shall be adjusted by the utility owner or the owner's representative or by the Contractor as a contract item. Generally, arrangements for adjusting known utilities will be made by the Department prior to project construction; however, utilities will not necessarily be adjusted in advance of project construction and, in some cases, utilities will not be removed from the proposed construction limits as described in Article 107.37. When utility adjustments must be performed in conjunction with construction, the utility adjustment work will be indicated in the contract.

The Contractor may make arrangements for adjustment of utilities indicated in the contract, but not scheduled by the Department for adjustment, provided the Contractor furnishes the Department with a signed agreement with the utility owner covering the adjustments to be made. The cost of any such adjustments shall be the responsibility of the Contractor.

107.39 Contractor's Responsibility for Locating and Protecting Utility Property and Services. At points where the Contractor's operations are adjacent to properties or facilities of utility companies, or are adjacent to other property, damage to which might result in considerable expense, loss, or inconvenience, work shall not be commenced until all arrangements necessary for the protection thereof have been made.

Within the State of Illinois, a State-Wide One Call Notice System has been established for notifying utilities. Outside the city limits of the City of Chicago, the system is known as the Joint Utility Locating Information for Excavators (JULIE) System. Within the city limits of the City of Chicago the system is known as DIGGER. All utility companies and municipalities which have buried utility facilities in the State of Illinois are a part of this system.

The Contractor shall call JULIE (800-892-0123) or DIGGER (312-744-7000), a minimum of 48 hours in advance of work being done in the area, and they will notify all member utility companies involved their respective utility should be located.

For utilities which are not members of JULIE or DIGGER, the Contractor shall contact the owners directly. The plan general notes will indicate which utilities are not members of JULIE or DIGGER.

The following table indicates the color of markings required of the State-Wide One Call Notification System.

| Utility Service | Color |
|---|--|
| Electric Power, Distribution and Transmission | Safety Red |
| Municipal Electric Systems | Safety Red |
| Gas Distribution and Transmission | High Visibility Safety Yellow |
| Oil Distribution and Transmission | High Visibility Safety Yellow |
| Telephone and Telegraph System | Safety Alert Orange |
| Community Antenna Television Systems | Safety Alert Orange |
| Water Systems | Safety Precaution Blue |
| Sewer Systems | Safety Green |
| Non-Potable Water and Slurry Lines | Safety Purple |
| Temporary Survey | Safety Pink |
| Proposed Excavation | Safety White (Black when snow is on the ground) |

The State-Wide One Call Notification System will provide for horizontal locations of utilities. When it is determined that the vertical location of the utility is necessary to facilitate construction, the Engineer may make the request for location from the utility after receipt of notice from the Contractor. If the utility owner does not field locate their facilities to the satisfaction of the Engineer, the Engineer will authorize the Contractor in writing to proceed to locate the facilities in the most economical and reasonable manner, subject to the approval of the Engineer, and be paid according to Article 109.04.

The Contractor shall be responsible for maintaining the excavations or markers provided by the utility owners.

The Contractor shall take all necessary precautions for the protection of the utility facilities. The Contractor shall be responsible for any damage or destruction of utility facilities resulting from neglect, misconduct, or omission in the Contractor's manner or method of execution or non-execution of the work, or caused by defective work or the use of unsatisfactory materials. Whenever any damage or destruction of a utility facility occurs as a result of work performed by the Contractor, the utility company will be immediately notified. The utility company will make arrangements to restore such facility to a condition equal to that existing before any such damage or destruction was done.

In the event of interruption of utility services as a result of accidental breakage or as a result of being exposed or unsupported, the Contractor shall promptly notify the proper authority and shall cooperate with the said authority in the restoration of service. If water service is interrupted, repair work shall be continuous until the service is restored. No work shall be undertaken around fire hydrants until provisions for continued service have been approved by the local fire authority.

107.40 Conflicts with Utilities. Except as provided hereinafter, the discovery of a utility in an unanticipated location will be evaluated according to Article 104.03. It is understood and agreed that the Contractor has considered in the bid all facilities not meeting the definition of a utility in an unanticipated location and no additional compensation will be allowed for any delays, inconveniences, or damages sustained by the Contractor due to the presence of or any claimed interference from such facilities.

When the Contractor discovers a utility in an unanticipated location, the Contractor shall not interfere with said utility, shall take proper precautions to prevent damage or interruption of the utility, and shall promptly notify the Engineer of the nature and location of said utility.

- (a) Definition. A utility in an unanticipated location is defined as an active or inactive utility, which is either:
- (1) Located underground and (a) not shown in any way in any location on the contract documents; (b) not identified in writing by the Department to the Contractor prior to the letting; or (c) not located relative to the location shown in the contract within the tolerances provided in 220 ILCS 50/2.8 or Administrative Code Title 92 Part 530.40(c); or
 - (2) Located above ground or underground and not relocated as provided in the contract.

Service connections shall not be considered to be utilities in unanticipated locations.

(b) Compensation. Compensation will not be allowed for delays, inconveniences, or damages sustained by the Contractor from conflicts with facilities not meeting the above definition; or if a conflict with a utility in an unanticipated location does not cause a shutdown of the work applicable to the utility or a documentable reduction in the rate of progress exceeding the limits set herein. The provisions of Article 104.03 notwithstanding, compensation for delays caused by a utility in an unanticipated location will be paid according to the provisions of this Article governing minor and major delays or reduced rate of production which are defined as follows:

- (1) Minor Delay. A minor delay occurs when the Contractor's operation is completely stopped by a utility in an unanticipated location for more than two hours, but not to exceed three weeks.
- (2) Major Delay. A major delay occurs when the Contractor's operation is completely stopped by a utility in an unanticipated location for more than three weeks.
- (3) Reduced Rate of Production Delay. A reduced rate of production delay occurs when the contractor's rate of production decreases by more than 25 percent and lasts longer than seven days.

(c) Payment. Payment for Minor, Major and Reduced Rate of Production Delays will be made as follows.

- (1) Minor Delay. Labor idled which cannot be used on other work will be paid for according to Article 109.04(b)(1) and (2) for the time between start of the delay and the minimum remaining hours in the work shift required by the prevailing practice in the area.

Equipment idled which cannot be used on other work, and which is authorized to standby on the project site by the Engineer, will be paid for according to Article 109.04(b)(4).

- (2) Major Delay. Labor will be the same as for a minor delay.

Equipment will be the same as for a minor delay, except Contractor-owned equipment will be limited to three weeks plus the cost of move-out to either the Contractor's yard or another job, whichever is less. Rental equipment may be paid for longer than three weeks provided the Contractor presents adequate support to the Department (including lease agreement) to show retaining equipment on the job is the most economical course to follow and in the public interest.

- (3) Reduced Rate of Production Delay. The Contractor will be compensated for the reduced productivity for labor and equipment time in excess of the 25 percent threshold for that portion of the delay in excess of seven days. Determination of compensation will be in accordance with Article 104.02, except labor and material additives will not be permitted.

Whether covered by (1), (2) or (3) above, additional traffic control required as a result of the operation(s) delayed will be paid for according to Article 109.04 for the total length of the delay.

If the delay is clearly shown to have caused work, which would have otherwise been completed, to be done after material or labor costs have increased, such increases may be paid. Payment for materials will be limited to increased cost substantiated by documentation furnished by the Contractor. Payment for increased labor rates will include those items in Article 109.04(b)(1) and (2), except the 35 percent and ten percent additives will not be permitted. On a working day contract, a delay occurring between November 30 and May 1, when work has not started, will not be considered as eligible for payment of measured labor and material costs.

Project overhead (not including interest) will be allowed when all progress on the contract has been delayed, and will be calculated as 15 percent of the delay claim.

- (d) Other Obligations of Contractor. Upon payment of a claim under this provision, the Contractor shall assign subrogation rights to the Department for the Department's efforts of recovery from any other party for monies paid by the Department as a result of any claim under this Provision. The Contractor shall fully cooperate with the Department in its efforts to recover from another party any money paid to the Contractor for delay damages under this Provision."

STEEL COST ADJUSTMENT (BDE) (RETURN FORM WITH BID)

Effective: April 2, 2004

Revised: April 1, 2009

Description. Steel cost adjustments will be made to provide additional compensation to the Contractor, or a credit to the Department, for fluctuations in steel prices when optioned by the Contractor. The bidder shall indicate on the attached form whether or not this special provision will be part of the contract and submit the completed form with his/her bid. Failure to submit the form or failure to indicate contract number, company name, and sign and date the form shall make this contract exempt of steel cost adjustments for all items of steel. Failure to indicate "Yes" for any item of work will make that item of steel exempt from steel cost adjustment.

Types of Steel Products. An adjustment will be made for fluctuations in the cost of steel used in the manufacture of the following items:

Metal Piling (excluding temporary sheet piling)
Structural Steel
Reinforcing Steel

Other steel materials such as dowel bars, tie bars, mesh reinforcement, guardrail, steel traffic signal and light poles, towers and mast arms, metal railings (excluding wire fence), and frames and grates will be subject to a steel cost adjustment when the pay items they are used in has a contract value of \$10,000 or greater.

Documentation. Sufficient documentation shall be furnished to the Engineer to verify the following:

- (a) The dates and quantity of steel, in lb (kg), shipped from the mill to the fabricator.
- (b) The quantity of steel, in lb (kg), incorporated into the various items of work covered by this special provision. The Department reserves the right to verify submitted quantities.

Method of Adjustment. Steel cost adjustments will be computed as follows:

$$SCA = Q \times D$$

Where: SCA = steel cost adjustment, in dollars
Q = quantity of steel incorporated into the work, in lb (kg)
D = price factor, in dollars per lb (kg)

$$D = MPI_M - MPI_L$$

Where: MPI_M = The Materials Cost Index for steel as published by the Engineering News-Record for the month the steel is shipped from the mill. The indices will be converted from dollars per 100 lb to dollars per lb (kg).
 MPI_L = The Materials Cost Index for steel as published by the Engineering News-Record for the month prior to the letting. The indices will be converted from dollars per 100 lb to dollars per lb (kg).

The unit weights (masses) of steel that will be used to calculate the steel cost adjustment for the various items are shown in the attached table.

No steel cost adjustment will be made for any products manufactured from steel having a mill shipping date prior to the letting date.

If the Contractor fails to provide the required documentation, the method of adjustment will be calculated as described above; however, the MPI_M will be based on the date the steel arrives at the job site. In this case, an adjustment will only be made when there is a decrease in steel costs.

Basis of Payment. Steel cost adjustments may be positive or negative but will only be made when there is a difference between the MPI_L and MPI_M in excess of five percent, as calculated by:

$$\text{Percent Difference} = \{(MPI_L - MPI_M) \div MPI_L\} \times 100$$

Steel cost adjustments will be calculated by the Engineer and will be paid or deducted when all other contract requirements for the items of work are satisfied. Adjustments will only be made for fluctuations in the cost of the steel as described herein. No adjustment will be made for changes in the cost of manufacturing, fabrication, shipping, storage, etc.

The adjustments shall not apply during contract time subject to liquidated damages for completion of the entire contract.

Attachment

| Item | Unit Mass (Weight) |
|---|--------------------------------|
| Metal Piling (excluding temporary sheet piling) | |
| Furnishing Metal Pile Shells 12 in. (305 mm), 0.179 in. (3.80 mm) wall thickness) | 23 lb/ft (34 kg/m) |
| Furnishing Metal Pile Shells 12 in. (305 mm), 0.250 in. (6.35 mm) wall thickness) | 32 lb/ft (48 kg/m) |
| Furnishing Metal Pile Shells 14 in. (356 mm), 0.250 in. (6.35 mm) wall thickness) | 37 lb/ft (55 kg/m) |
| Other piling | See plans |
| Structural Steel | See plans for weights (masses) |
| Reinforcing Steel | See plans for weights (masses) |
| Dowel Bars and Tie Bars | 6 lb (3 kg) each |
| Mesh Reinforcement | 63 lb/100 sq ft (310 kg/sq m) |
| Guardrail | |
| Steel Plate Beam Guardrail, Type A w/steel posts | 20 lb/ft (30 kg/m) |
| Steel Plate Beam Guardrail, Type B w/steel posts | 30 lb/ft (45 kg/m) |
| Steel Plate Beam Guardrail, Types A and B w/wood posts | 8 lb/ft (12 kg/m) |
| Steel Plate Beam Guardrail, Type 2 | 305 lb (140 kg) each |
| Steel Plate Beam Guardrail, Type 6 | 1260 lb (570 kg) each |
| Traffic Barrier Terminal, Type 1 Special (Tangent) | 730 lb (330 kg) each |
| Traffic Barrier Terminal, Type 1 Special (Flared) | 410 lb (185 kg) each |
| Steel Traffic Signal and Light Poles, Towers and Mast Arms | |
| Traffic Signal Post | 11 lb/ft (16 kg/m) |
| Light Pole, Tenon Mount and Twin Mount, 30 - 40 ft (9 - 12 m) | 14 lb/ft (21 kg/m) |
| Light Pole, Tenon Mount and Twin Mount, 45 - 55 ft (13.5 - 16.5 m) | 21 lb/ft (31 kg/m) |
| Light Pole w/Mast Arm, 30 - 50 ft (9 - 15.2 m) | 13 lb/ft (19 kg/m) |
| Light Pole w/Mast Arm, 55 - 60 ft (16.5 - 18 m) | 19 lb/ft (28 kg/m) |
| Light Tower w/Luminaire Mount, 80 - 110 ft (24 - 33.5 m) | 31 lb/ft (46 kg/m) |
| Light Tower w/Luminaire Mount, 120 - 140 ft (36.5 - 42.5 m) | 65 lb/ft (97 kg/m) |
| Light Tower w/Luminaire Mount, 150 - 160 ft (45.5 - 48.5 m) | 80 lb/ft (119 kg/m) |
| Metal Railings (excluding wire fence) | |
| Steel Railing, Type SM | 64 lb/ft (95 kg/m) |
| Steel Railing, Type S-1 | 39 lb/ft (58 kg/m) |
| Steel Railing, Type T-1 | 53 lb/ft (79 kg/m) |
| Steel Bridge Rail | 52 lb/ft (77 kg/m) |
| Frames and Grates | |
| Frame | 250 lb (115 kg) |
| Lids and Grates | 150 lb (70 kg) |

RETURN WITH BID

**ILLINOIS DEPARTMENT
OF TRANSPORTATION**

**OPTION FOR
STEEL COST ADJUSTMENT**

The bidder shall submit this completed form with his/her bid. Failure to submit the form or properly complete contract number, company name, and sign and date the form shall make this contract exempt of steel cost adjustments for all items of steel. Failure to indicate "Yes" for any item of work will make that item of steel exempt from steel cost adjustment. After award, this form, when submitted shall become part of the contract.

Contract No.: _____

Company Name: _____

Contractor's Option:

Is your company opting to include this special provision as part of the contract plans for the following items of work?

- Metal Piling Yes
- Structural Steel Yes
- Reinforcing Steel Yes
- Dowel Bars, Tie Bars and Mesh Reinforcement Yes
- Guardrail Yes
- Steel Traffic Signal and Light Poles, Towers and Mast Arms Yes
- Metal Railings (excluding wire fence) Yes
- Frames and Grates Yes

Signature: _____ **Date:** _____

STATE OF ILLINOIS

DEPARTMENT OF TRANSPORTATION

PLANS FOR PROPOSED

VARIOUS ROUTES
SECTION DIST 8
GUARDRAIL 2013-1

VARIOUS COUNTIES
C-98-063-12
GUARDRAIL REPAIR &
CABLE RAIL

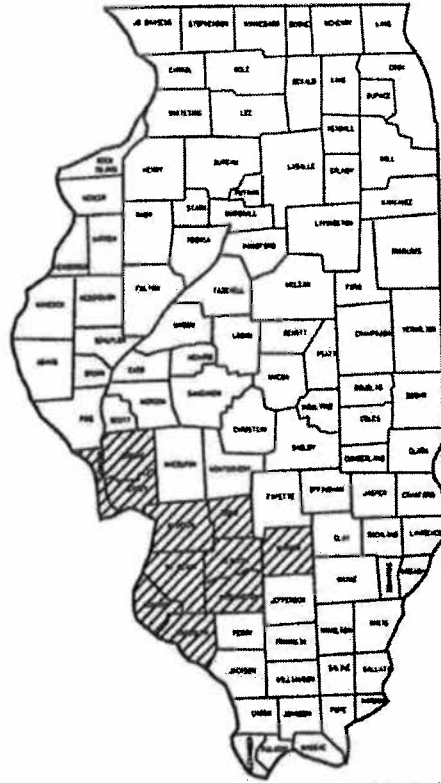

LOCATION OF SECTION INDICATED THUS 

D-98-057-12

SEE PAGE 2
FOR LOCATION MAP

JOINT UTILITY LOCATION
INFORMATION FOR EXCAVATIONS
PHONE: (800) 892-0123

SUBMITTED March 29, 2012

[Signature]
DEPUTY DIRECTOR OF HIGHWAYS
REGION FIVE ENGINEER

PASSED _____

ENGINEER OF DESIGN & ENVIRONMENT

APPROVED _____

DIRECTOR, DIVISION OF HIGHWAYS

PRINTED BY THE AUTHORITY OF THE STATE OF ILLINOIS
PLOT DATE: 3/27/2012

CONTRACT NO. 76F72

3/27/2012
PROJECT ENGINEER: PATTI LEBEAU (618) 346-3179
SQUAD LEADER: BILLIE OWEN (618) 346-3186
REF-
REF-
REF-

| TOTAL SHEETS | SHEET NO. |
|--------------------|-----------|
| 17 | 2 |
| CONTRACT NO. 76F72 | |

INDEX OF SHEETS

- 1 COVER SHEET
- 2 LOCATION MAP, INDEX OF SHEETS
- 3-5 HIGHWAY STANDARDS AND GENERAL NOTES
- 6-8 SUMMARY OF QUANTITIES
- 9-17 GUARDRAIL DETAILS

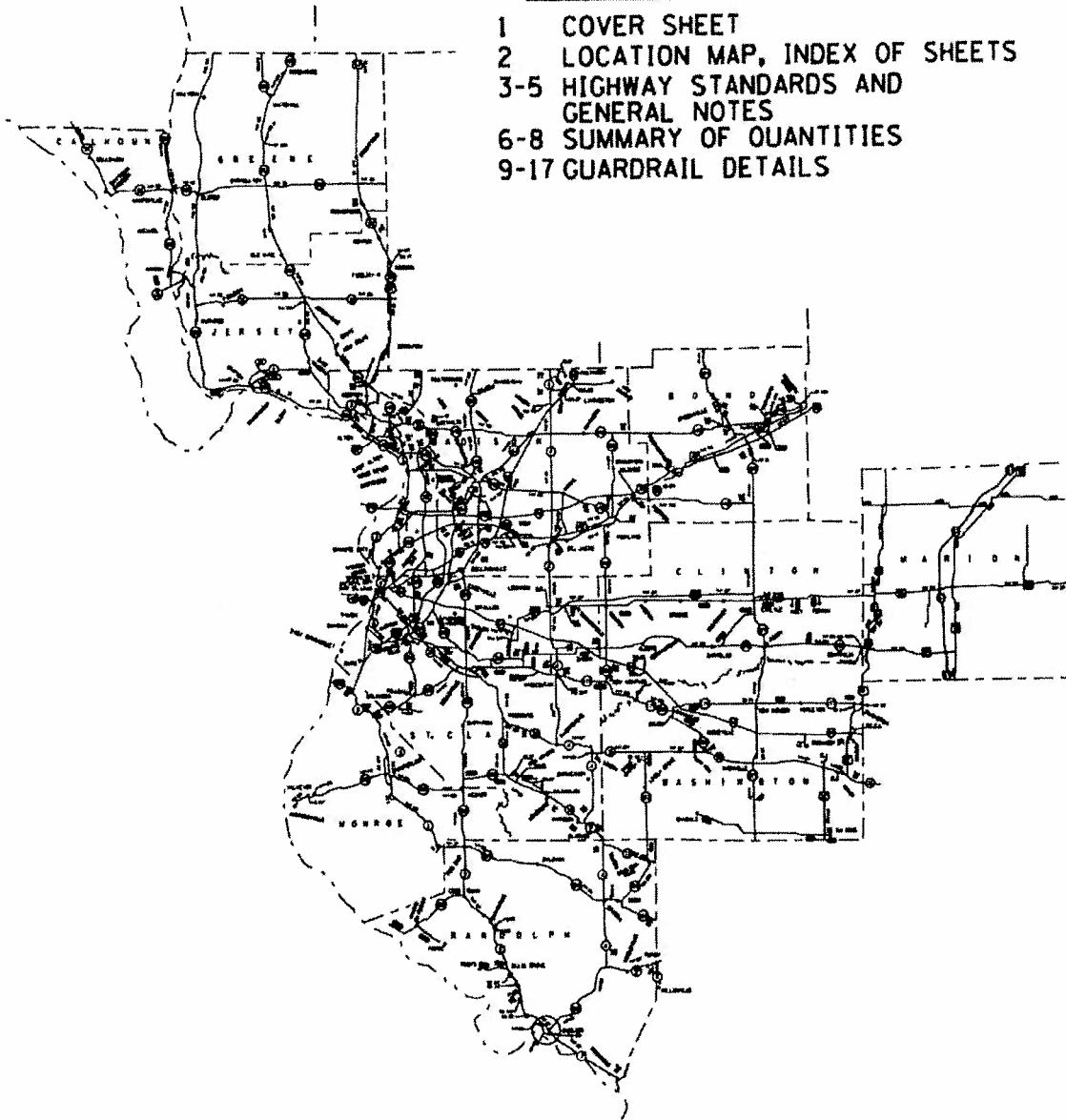

LOCATION MAP
AND
INDEX OF SHEETS
VARIOUS ROUTES
SECTION DIST 8 GUARDRAIL 2013-1
VARIOUS COUNTIES

PLOT DATE: 3/27/2012

HIGHWAY STANDARDS

| TOTAL SHEETS | SHEET NO. |
|--------------------|-----------|
| 17 | 3 |
| CONTRACT NO. 76F72 | |

| | | | | |
|-----------|-----------|-----------|-----------|-----------|
| 630001-10 | 631026-05 | 701001-02 | 701201-04 | 701701-08 |
| 630101-09 | 631031-10 | 701006-03 | 701301-04 | 701901-02 |
| 630301-05 | 635001-01 | 701011-02 | 701400-05 | 000001-06 |
| 631006-08 | 635006-03 | 701101-02 | 701406-06 | |
| 631011-08 | 636001-02 | 701106-02 | 701421-04 | |

GENERAL NOTES

1. BEFORE ORDERING THE IMPACT ATTENUATORS, THE CONTRACTOR MUST CONTACT THE MAINTENANCE ENGINEER AT (618) 346-3279 OR (618) 346-3233 TO RECEIVE APPROVAL OF THE PROPOSED INSTALLATION.
2. ALL WORK IS TO BE REPLACED IN KIND OR AS INDICATED ON THE CONTRACT PLANS AND PROVISIONS.
3. THE LOCATIONS OF THE REPAIR AREAS SHALL BE DETERMINED BY THE ENGINEER.
4. GUARDRAIL WORK WILL INCLUDE ALIGNMENT AS NECESSARY TO RESTORE THE RAIL AND POST TO THE ORIGINAL CONDITIONS.
5. REMOVAL OF DAMAGED MATERIALS WILL INCLUDE DISMANTLING, LOADING, HAULING, AND DISPOSAL. THE WORK SITE WILL BE LEFT IN A SAFE AND ORDERLY CONDITION.
6. NO MATERIAL SHALL BE LEFT ON OR NEAR THE ROADWAY DURING NON-WORKING HOURS.
7. ANY NECESSARY TRAFFIC CONTROL WILL BE PROVIDED BY THE CONTRACTOR; APPROPRIATE STANDARDS ARE LISTED ABOVE.
8. THE LIMITS OF THE DAMAGED GUARDRAIL WILL BE MARKED WITH PAINT. THE REPLACEMENT PARTS AND THE QUANTITIES INDICATED ARE WITHIN THESE LIMITS AS MARKED.
9. REMOVED GUARDRAIL THAT IS NOT REPLACED ON THE SAME DAY MUST BE DELINEATED WITH LIGHTED BARRICADES. NO LOCATIONS WILL BE LEFT WITHOUT EITHER LIGHTED BARRICADES OR RESTORED GUARDRAIL AT ANY TIME.
10. GUARDRAIL MARKERS SHALL NOT BE ATTACHED TO TERMINAL SECTIONS. ALL OTHER MARKERS SHALL BE PLACED AT THE DISCRETION OF THE ENGINEER. COST OF MARKERS TO BE INCLUDED IN THE GUARDRAIL PAY ITEMS.
11. ILLINOIS STATE LAW REQUIRES A 48-HOUR NOTICE TO BE GIVEN TO UTILITIES BEFORE DIGGING. FIELD MARKING OF FACILITIES MAY BE OBTAINED BY CONTACTING J.U.L.I.E. (PHONE: 800 892-0123) OR FOR NON-MEMBER, THE UTILITY COMPANY DIRECTLY.

HIGHWAY STANDARDS AND GENERAL NOTES

VARIOUS ROUTES
SECTION DIST 8 GUARDRAIL 2013-1
VARIOUS COUNTIES

PLOT DATE: 3/27/2012

| | |
|---------------------|-----------|
| TOTAL SHEETS | SHEET NO. |
| 17 | 4 |
| CONTRACT NO.: 76F72 | |

GENERAL NOTES (CONTINUED)

12. A FLAGGER SHALL BE REQUIRED AT ALL TIMES WHEN WORKERS OR EQUIPMENT ARE ENCROACHING THE LANE OF TRAFFIC.
13. WHEN NO WORK IS BEING PERFORMED, THE FLAGGERS WILL NOT BE REQUIRED. IF THE FLAGGERS ARE NOT PRESENT, THE FLAGGER SIGNS SHALL BE REMOVED OR COVERED.
14. LIGHTS WILL NOT BE REQUIRED FOR DAY OPERATIONS.
15. UTILITY INTERFERENCES ARE NOT ANTICIPATED ON THIS CONTRACT. IT SHALL BE THE CONTRACTORS RESPONSIBILITY TO COORDINATE HIS CONSTRUCTION ACTIVITIES WITH THE VARIOUS UTILITY OWNERS. ALL POTENTIAL CONFLICTS SHALL BE INVESTIGATED AND REMEDIAL ACTION TAKEN PRIOR TO INTERRUPTION OF THE CONTRACTORS PROGRESS. NO ADDITIONAL COST SHALL BE ADDED TO THE CONTRACT RESULTING FROM UTILITY CONFLICTS.
16. ALL EXCAVATION ADJACENT TO THE EDGE OF PAVEMENT SHALL BE PROTECTED WITH THE EXTENDED LEG BARRICADES AND THE APPROPRIATE LIGHTS.
17. PRIOR TO ORDERING ANY MATERIALS, THE CONTRACTOR SHALL CONFIRM THE TYPES AND SPECIFIC MANUFACTURER FOR THE GUARDRAIL AND CABLE REPAIRS REQUIRED.
18. 45 & 55 MPH SIGNS ARE INCLUDED IN ALL INTERSTATE LANE CLOSURES. IF THE LANE CLOSURE DURATION IS LESS THAN 4 HOURS, THE 45 & 55 MPH SIGNS ARE NOT REQUIRED.
19. ANY JOB MAY BE CANCELLED AT THE ENGINEER'S DISCRETION.
20. CORTEN ITEMS SHALL BE PAID FOR THE SAME AS REGULAR ITEMS.
21. NO OVERNIGHT LANE CLOSURES WILL BE ALLOWED.
22. ARTICLE 701.20 OF THE STANDARD SPECIFICATIONS DISCUSSED AN ADJUSTED UNIT PRICE. NO ADJUSTMENTS SHALL BE MADE TO THE TRAFFIC CONTROL PAY ITEMS FOR THIS CONTRACT.
23. THE CONTRACTOR SHALL BE ADVISED THAT THE GUARDRAIL PAY ITEMS INCLUDED IN THE PLANS MAY BE USED TO REPLACE/REPAIR SPBGR AND TRAFFIC BARRIER TERMINALS FOR EITHER THE CURRENT MIDWEST STYLES AS SHOWN IN THE HIGHWAY STANDARDS OR SPBGR AND TRAFFIC BARRIER TERMINAL INSTALLED PRIOR TO JAN. 1 2007 AS SHOWN IN THE PLAN DETAILS. NO ADDITIONAL COMPENSATION WILL BE ALLOWED FOR UTILIZING THE CURRENT MIDWEST STANDARDS.

GENERAL NOTES (CONT.)

VARIOUS BOQUIES
SECTION DIST 8 GUARDRAIL 2013-1
VARIOUS COUNTIES

PLOT DATE: 3/29/2012

GENERAL NOTES (CONTINUED)

24. THE FOLLOWING ARE THE ANTICIPATED NUMBER OF SETUPS FOR TRAFFIC CONTROL AND PROTECTION ITEMS:

| STANDARD | ESTIMATED NUMBER OF SETUPS |
|----------|----------------------------|
| 701201 | 60 |
| 701406 | 100 |
| 701421 | 50 |
| 701701 | 1 |

THE ABOVE ESTIMATES ARE APPROXIMATE AND ARE INCLUDED IN THE L SUM COST.

25. THE COST OF REMOVING AND DISPOSING OF DAMAGED END SECTIONS IS INCLUDED IN THE PRICE FOR THE APPROPRIATE TRAFFIC BARRIER TERMINAL.

GENERAL NOTES (CONT.)

VARIOUS ROUTES
SECTION DIST 8 GUARDRAIL 2013-1
VARIOUS COUNTIES

SUMMARY OF QUANTITIES

| | |
|--------------------|-----------|
| TOTAL SHEETS | SHEET NO. |
| 17 | 6 |
| CONTRACT NO. 76F72 | |

| CODE NO | ITEM | UNIT | 100% STATE 0021 TOTAL QUANTITIES |
|----------|---|-------|---|
| 63100041 | TRAFFIC BARRIER TERMINAL, TYPE 1B | EACH | 5 |
| 63100045 | TRAFFIC BARRIER TERMINAL, TYPE 2 | EACH | 3 |
| 63100070 | TRAFFIC BARRIER TERMINAL, TYPE 5 | EACH | 2 |
| 63100085 | TRAFFIC BARRIER TERMINAL, TYPE 6 | EACH | 6 |
| 63100167 | TRAFFIC BARRIER TERMINAL, TYPE 1 (SPECIAL) TANGENT | EACH | 64 |
| 63100169 | TRAFFIC BARRIER TERMINAL, TYPE 1 (SPECIAL) FLARED | EACH | 5 |
| 64300260 | IMPACT ATTENUATORS (FULLY REDIRECTIVE, NARROW), TEST LEVEL 3 | EACH | 2 |
| 64300370 | IMPACT ATTENUATORS (FULLY REDIRECTIVE, WIDE), TEST LEVEL 3 | EACH | 2 |
| 67100100 | MOBILIZATION | L SUM | 1 |
| 70100310 | TRAFFIC CONTROL AND PROTECTION, STANDARD 701421 | L SUM | 1 |
| 70100450 | TRAFFIC CONTROL AND PROTECTION, STANDARD 701201 | L SUM | 1 |
| 70100700 | TRAFFIC CONTROL AND PROTECTION, STANDARD 701406 | L SUM | 1 |
| 70102635 | TRAFFIC CONTROL AND PROTECTION, STANDARD 701701 | L SUM | 1 |
| 78201000 | TERMINAL MARKER - DIRECT APPLIED | EACH | 69 |
| X0325972 | CABLE GUARD POST | EACH | 50 |
| X0326466 | HIGH TENSION CABLE POST REPAIR | EACH | 10 |

SUMMARY OF QUANTITIES

VARIOUS ROUTES
SECTION DIST 8 GUARDRAIL 2013-1
VARIOUS COUNTIES

PLOT DATE: 3/27/2012

SUMMARY OF QUANTITIES

| | |
|--------------|-----------|
| TOTAL SHEETS | SHEET NO. |
| 17 | 7 |

CONTRACT NO. 76F72

| CODE NO | ITEM | UNIT | 100% STATE |
|----------|--|------|-----------------------------|
| | | | 0021 TOTAL QUANTITIES |
| X0326468 | MEDIAN CABLE | FOOT | 100 |
| X6300210 | GUARDRAIL BLOCKS | EACH | 300 |
| X6300215 | RAIL ELEMENT PLATES | EACH | 225 |
| X6300220 | EXTRUDER HEAD | EACH | 10 |
| X6300225 | SINGLE END SECTION | EACH | 2 |
| X6300230 | STEEL POSTS | EACH | 250 |
| X6331110 | STEEL POSTS, SPECIAL | EACH | 10 |
| X8030110 | LOCATING UNDERGROUND CABLE, SPECIAL | EACH | 5 |
| Z0029658 | REPAIR TRAFFIC BARRIER TERMINAL TYPE 1 SPECIAL - POST | EACH | 14 |
| Z0050000 | REMOVAL AND REINSTALLATION OF EXISTING IMPACT ATTENUATORS | EACH | 20 |
| Z0052410 | REPAIR TRAFFIC BARRIER TERMINAL, TYPE 1 SPECIAL (TANGENT) | EACH | 44 |
| Z0052415 | REPAIR TRAFFIC BARRIER TERMINAL, TYPE 1 SPECIAL (FLARED) | EACH | 10 |
| Z0052600 | REPAIR TRAFFIC BARRIER TERMINAL, TYPE 2 | EACH | 5 |
| Z0052800 | REPAIR TRAFFIC BARRIER TERMINAL, TYPE 3A | EACH | 5 |
| Z0053000 | REPAIR TRAFFIC BARRIER TERMINAL, TYPE 5 | EACH | 2 |
| Z0053200 | REPAIR TRAFFIC BARRIER TERMINAL, TYPE 6 | EACH | 5 |

SUMMARY OF QUANTITIES

VARIOUS ROUTES
SECTION DIST 8 GUARDRAIL 2013-1
VARIOUS COUNTIES

PLOT DATE: 3/27/2012

SUMMARY OF QUANTITIES

| | |
|--------------------|-----------|
| TOTAL SHEETS | SHEET NO. |
| 17 | 8 |
| CONTRACT NO. 76F72 | |

| CODE NO | ITEM | UNIT | 100% STATE 0021 TOTAL QUANTITIES |
|----------|--|------|---|
| Z0059660 | REPAIR TRAFFIC BARRIER TERMINAL TYPE 1 SPECIAL - RAIL ELEMENT PLATE | EACH | 7 |
| Z0029655 | HIGH TENSION CABLE ROAD GUARDPOST | EACH | 200 |
| X630231 | STEEL POST, ATTACHED TO STRUCTURE | EACH | 3 |
| Z0029662 | REPLACE HIGH TENSION CABLE GUARDPOST FOUNDATION | EACH | 5 |

SUMMARY OF QUANTITIES

VARIOUS ROUTES
SECTION DIST 8 GUARDRAIL 2013-1
VARIOUS COUNTIES

PLOT DATE: 3/27/2012

| | |
|---------------------|-----------|
| TOTAL SHEETS | SHEET NO. |
| 17 | 9 |
| CONTRACT NO.: 76F72 | |

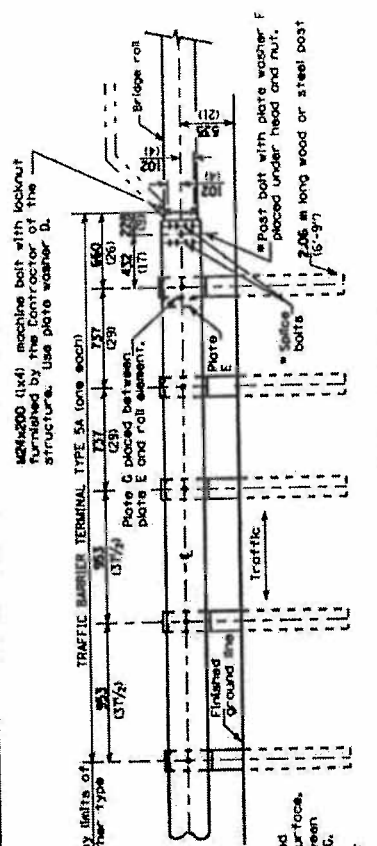

TYPE 5A - STEEL BRIDGE RAIL

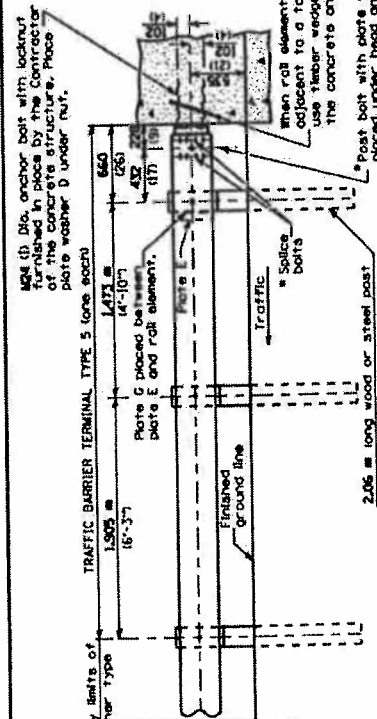
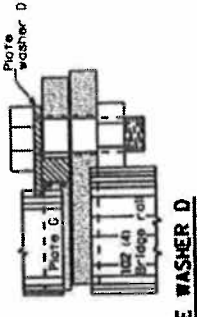

TYPE 5 - CONCRETE BRIDGE PARAPET

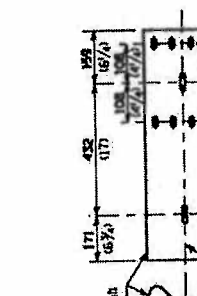

PLATE E

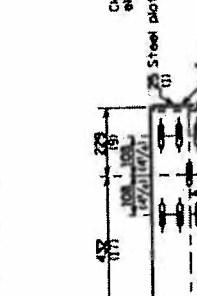

PLATE G

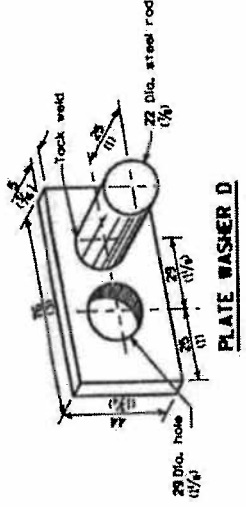
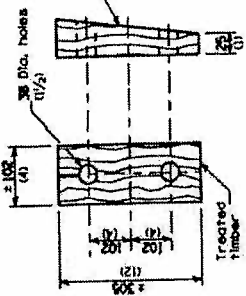

PLATE WASHER D



WEDGE M

GENERAL NOTES

- Install plate washer D so that the 25 mm (1") projection fills the remainder of the slotted holes in the 25 mm (1") end plate on plate G after the M24 (1") dia. bolts are in place.
- Bolts shall be provided with locknut or double nut and shall be tightened only to a point that will allow plate G to be free to move when an expansion joint exists below the connector.
- All dimensions are in millimeters (inches) unless otherwise shown.

TRAFFIC BARRIER TERMINAL TYPE 5 & 5A
VARIOUS ROUTES
SECTION DIST 8 GUARDRAIL 2013-1
VARIOUS COUNTIES

This detail is applicable to the Guardrail system used prior to January 1, 2007. For details on the Midwest Guardrail System, see Standard 630001.

**PARAPET
OR WINGWALL**

| | |
|--------------------|-----------|
| TOTAL SHEETS | SHEET NO. |
| 17 | 10 |
| CONTRACT NO. T&E72 | |

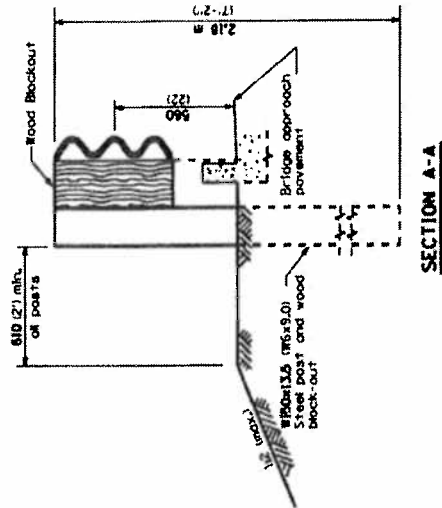
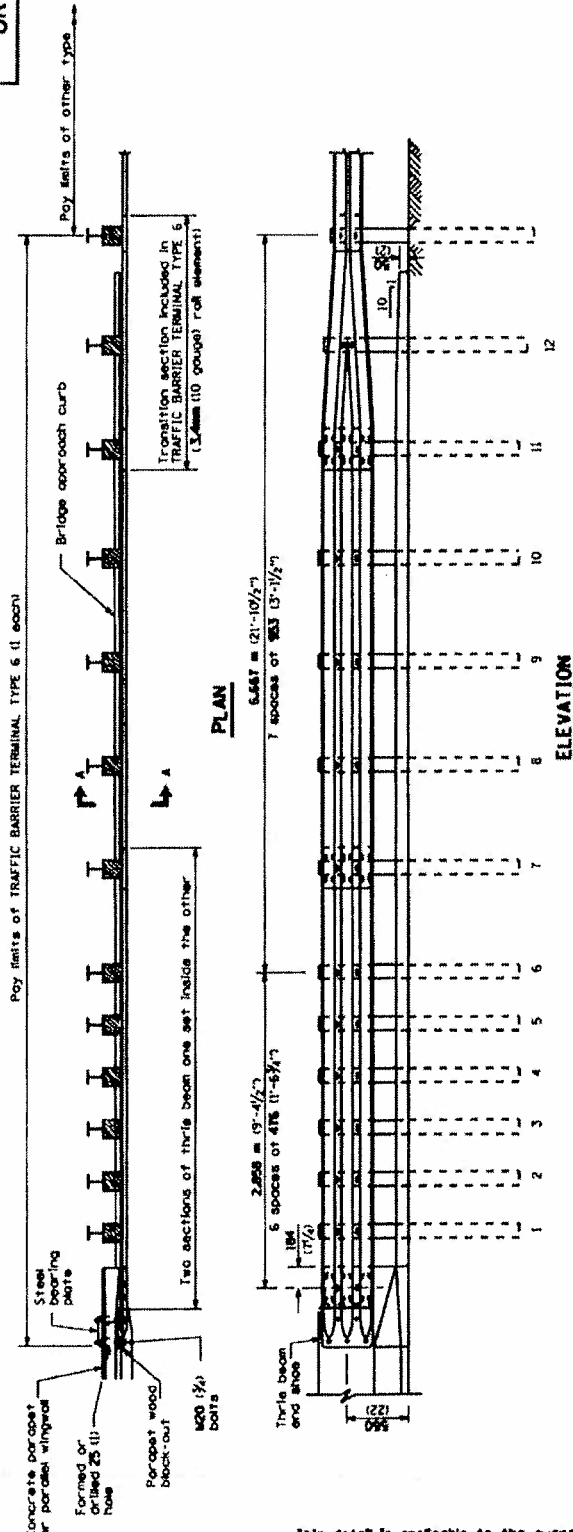

GENERAL NOTES

- Thrie beam roll shall be bolted to block-out of all posts.
- All slope ratios are expressed as units of vertical displacement to units of horizontal displacement (V:H).
- All dimensions are in millimeters (inches) unless otherwise shown.

**TRAFFIC BARRIER
TERMINAL, TYPE 6**

VARIOUS ROUTES
SECTION DIST 8 GUARDRAIL 2013-1
VARIOUS COUNTIES

This detail is applicable to the guardrail system used prior to January 1, 2007. For details on the M-FAST Guardrail System, see Standard 630001.

OTHER CONCRETE STRUCTURE

| | |
|--------------------|-----------|
| TOTAL SHEETS | SHEET NO. |
| 17 | 11 |
| CONTRACT NO. 16F72 | |

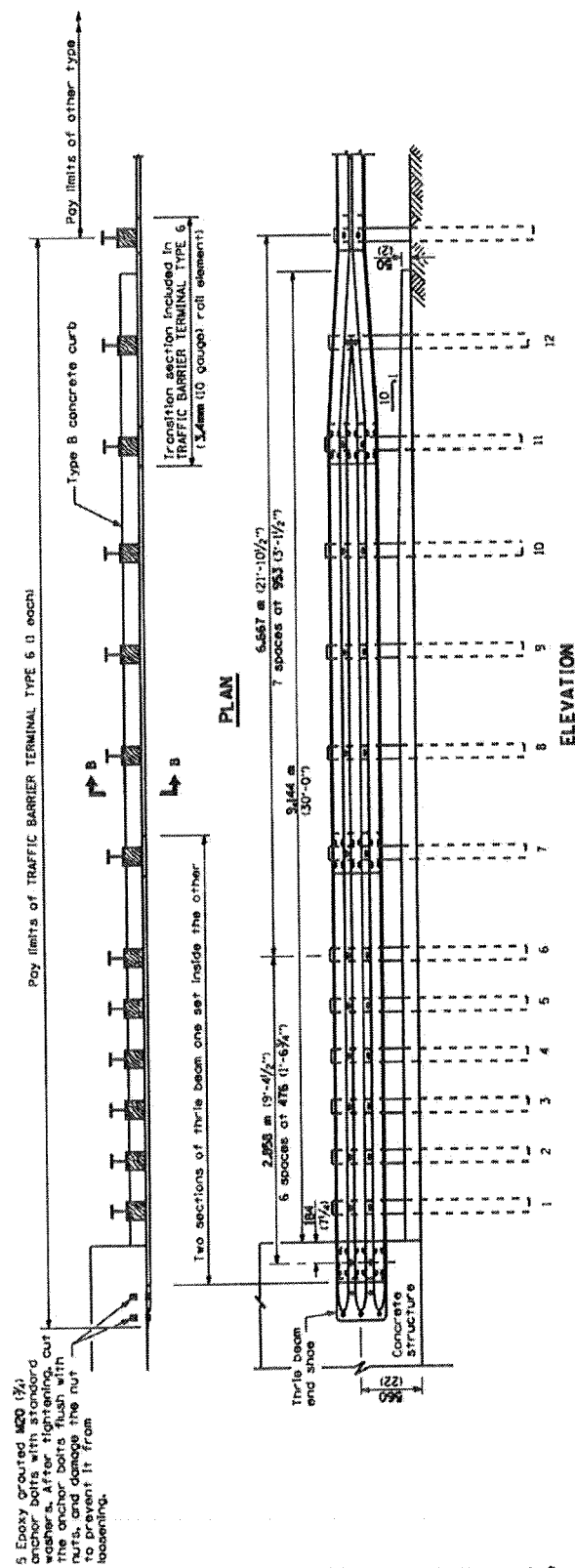

5. Epoxy grouted M20 (2) anchor bolts with standard washers. After tightening, cut the anchor bolts flush with nuts, and damage the nut to prevent it from loosening.

This detail is applicable to the guardrail system used prior to January 1, 2007. For details on the Midpass Guardrail System, see Standard 630001.

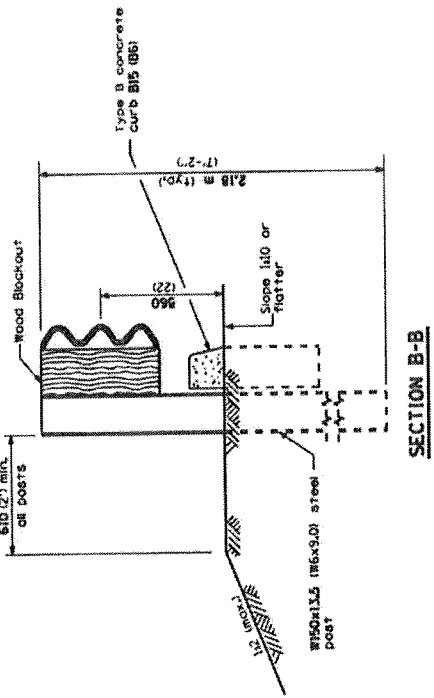

**TRAFFIC BARRIER
TERMINAL, TYPE 6**

VARIOUS ROUTES
SECTION DIST 8 GUARDRAIL 2013-1
VARIOUS COUNTIES

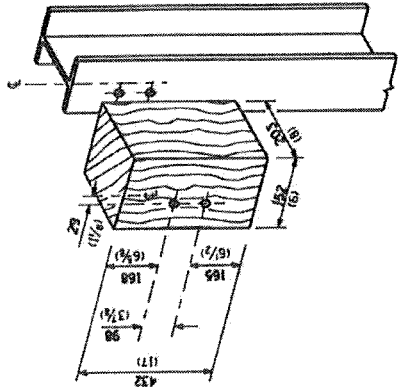

POST 12 WOOD BLOCKOUT DETAIL

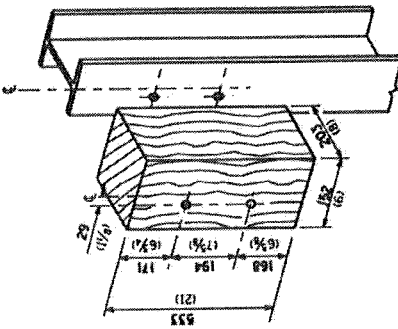

POSTS 1-11 WOOD BLOCKOUT DETAIL

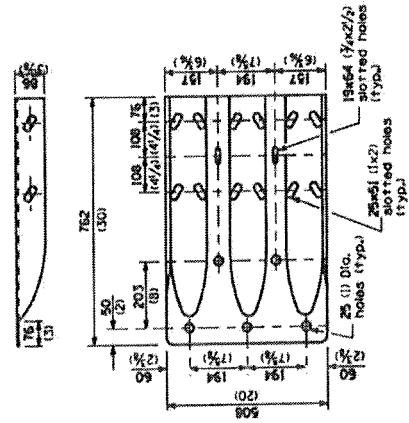

THREE BEAM END SHOE DETAIL

This detail is applicable to the guardrail system used prior to January 1, 2007. For details on the latest Guardrail System, see Standard 630001.

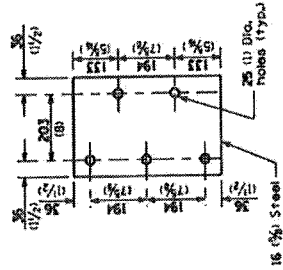

PARAPET STEEL BEARING PLATE DETAIL

15 each individual 125x125x16 15x5x3/8 steel plates with centered 25 (Ø) holes may be substituted for the plate shown.

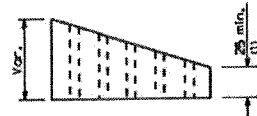

PARAPET WOOD BLOCK-OUT DETAIL

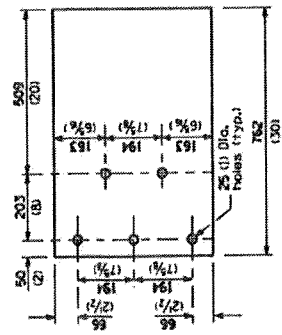

TRAFFIC BARRIER
TERMINAL, TYPE 6

VARIOUS ROUTES
SECTION DIST 8 GUARDRAIL 2013-1
VARIOUS COUNTIES

| | |
|--------------------|-----------|
| TOTAL SHEETS | SHEET NO. |
| 17 | 13 |
| CONTRACT NO. 76F72 | |

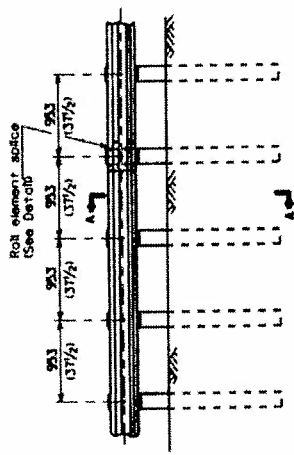

ELEVATION
TYPE B
963 (37 1/2) Closed post spacing

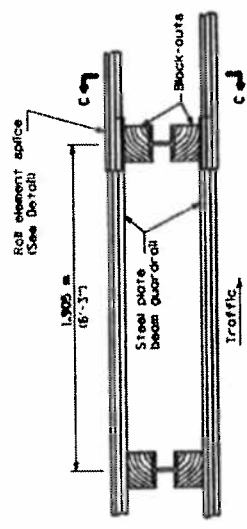

PLAN
TYPE D
Double steel plate beam guardrail
1,905 (6'-3 3/4) typical post spacing

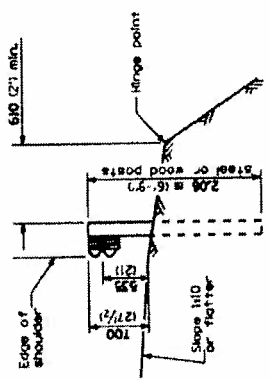

SECTION A-A

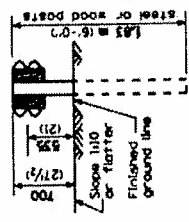

SECTION C-C

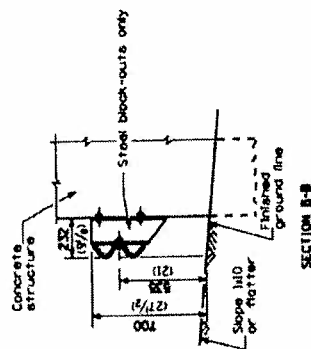

SECTION B-B

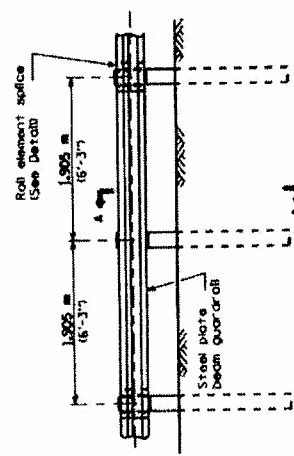

ELEVATION
TYPE A
1,905 (6'-3 3/4) Typical post spacing

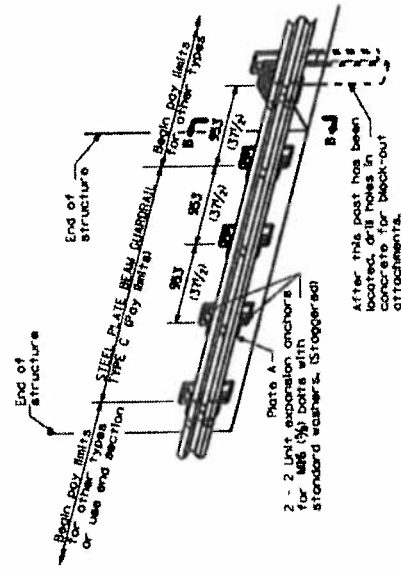

TYPE C
963 (37 1/2) Block-out spacing

GENERAL NOTES

All slope ratios are expressed as units of vertical displacement to units of horizontal displacement (V:H).

All dimensions are in millimeters (inches) unless otherwise shown.

The existing steel posts may be drilled to match the bolt pattern shown herein for the wood block-out, or a new steel post shall be provided.

This detail is applicable to the guardrail system used prior to January 1, 2007. For details on the Midwest Guardrail System, see Standard 630001.

STEEL PLATE BEAM GUARDRAIL

VARIOUS ROUTES
SECTION DIST 8 GUARDRAIL 2013-1
VARIOUS COUNTIES

This detail is applicable to the guardrail system used prior to January 1, 2007. For details on the Midwest Guardrail System, see Standard 630001.

| | |
|--------------------|-----------|
| TOTAL SHEETS | SHEET NO. |
| 17 | 14 |
| CONTRACT NO. 76F72 | |

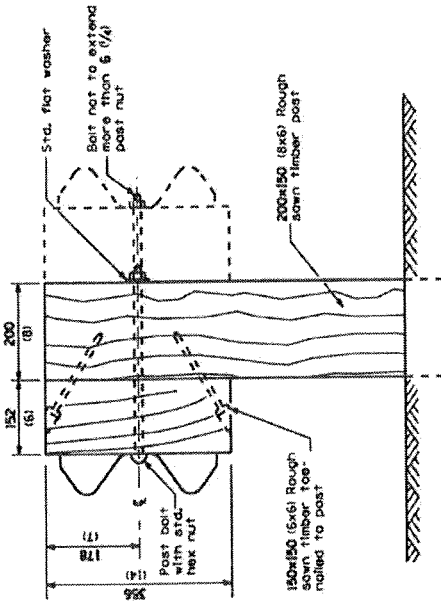

WOOD POST CONSTRUCTION

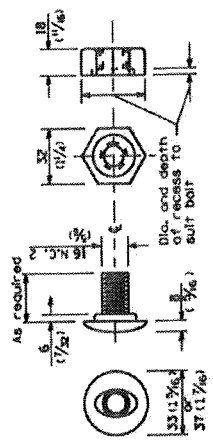

POST OR SPLICE BOLT & NUT

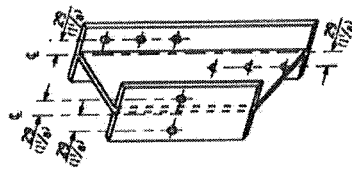

STEEL BLOCK-OUT DETAIL

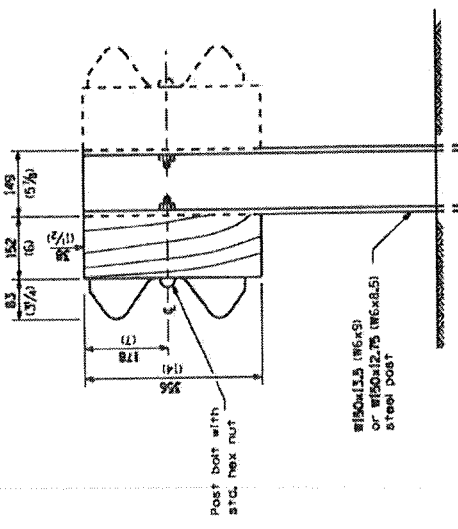

STEEL POST CONSTRUCTION

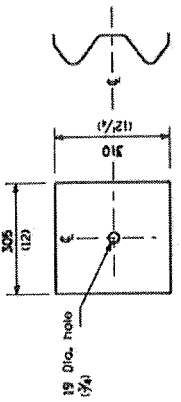

NOTE

Plate A shall be placed between rail element and block-out at non-splice mounting points only when steel block-outs are used.

PLATE A

This detail is applicable to the guardrail system used prior to January 1, 2007. For details on the Midwest Guardrail System, see Standard 630001.

STEEL PLATE BEAM GUARDRAIL

VARIOUS ROUTES
SECTION DIST 8 GUARDRAIL 2013-1
VARIOUS COUNTIES

PLOT DATE: 3/27/2012

| | |
|--------------------|-----------|
| TOTAL SHEETS | SHEET NO. |
| 17 | 15 |
| CONTRACT NO. 76F72 | |

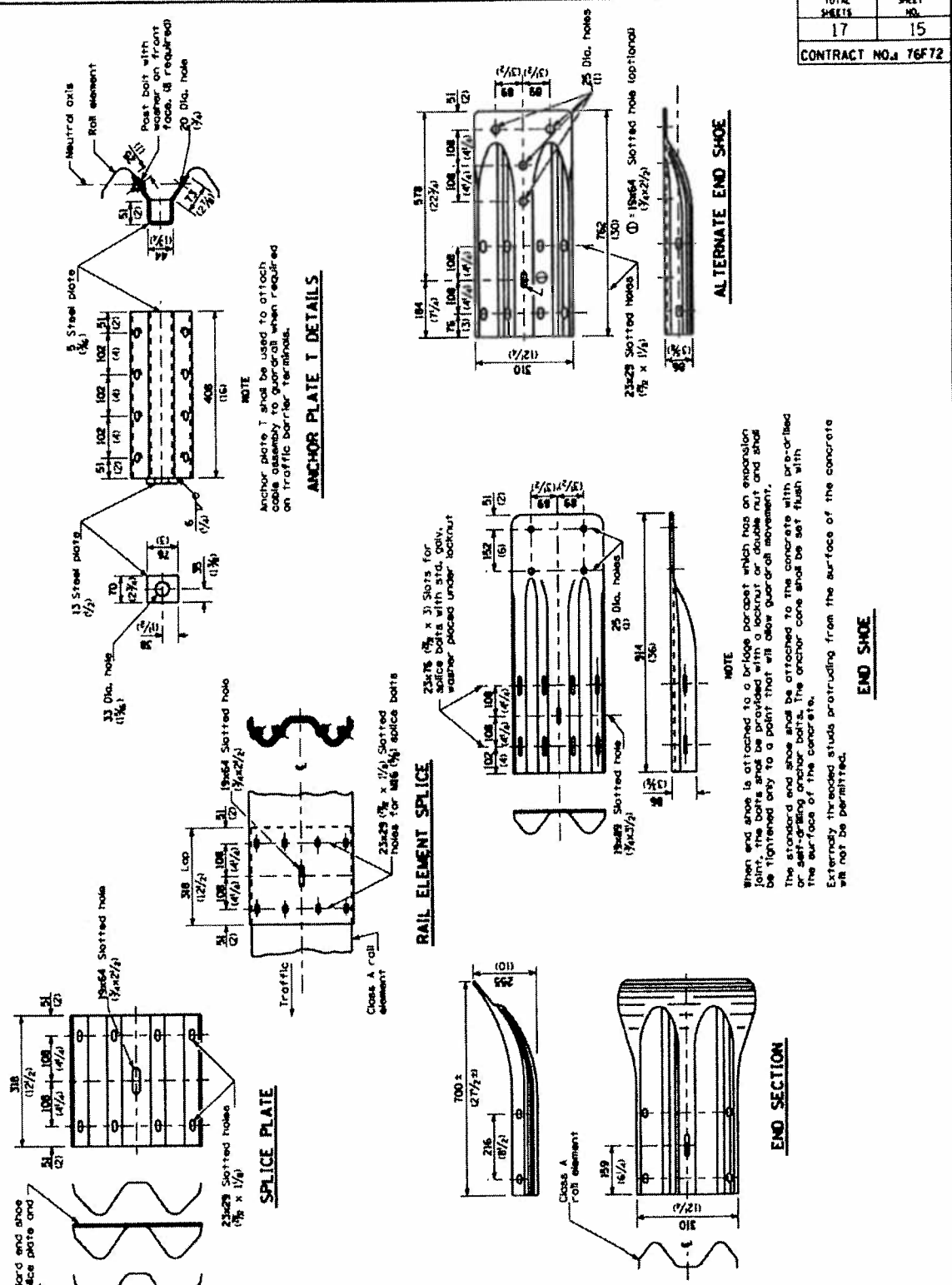

**STEEL PLATE BEAM
GUARDRAIL**

VARIOUS ROUTES
SECTION DIST 8 GUARDRAIL 2013-1
VARIOUS COUNTIES

PLOT DATE: 3/27/2012

This detail is applicable to the guardrail system used prior to January 1, 2007. For details on the Midwest Guardrail System, see Standard 630001.

| | |
|--------------------|-----------|
| TOTAL SHEETS | SHEET NO. |
| 17 | 16 |
| CONTRACT NO. 76F72 | |

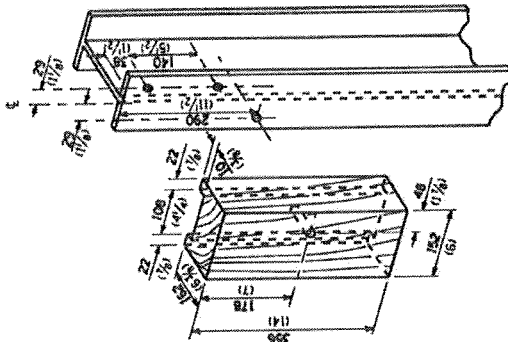

WOOD BLOCK-OUT AND STEEL POST DETAILS

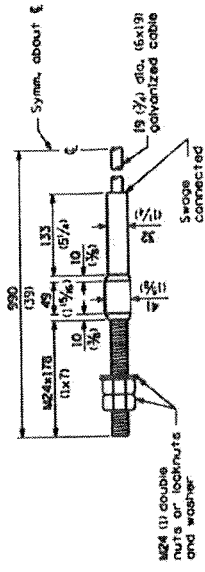

CABLE ASSEMBLY
118,100 kg (260,000 lbs.) min. breaking strength
Tighten to 40% tension.

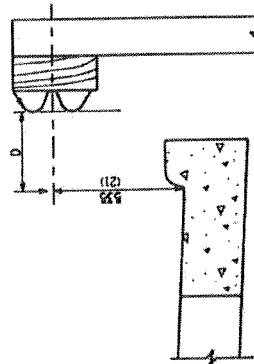

Notes:
If it is necessary for D to be more than 300 (121) and less than 330 mm (10'-0"), type M-5 (M-2) curb and gutter (Std. 606001) shall be used in front of and in advance of the guardrail.

GUARDRAIL PLACED BEHIND CURB

(D = 0 desirable to 300 (121) maximum)

| V | W | L | |
|-------------------------------|---------------------|-------------|-------------|
| | | Steel Post | Wood Post |
| 0 - 460 (0 - 181) | 610 (241) | 530 (21) | 590 (23) |
| 5460 - 825 (D:18 - 41.5) | 305 (12) | 203 (8) | 250 (10) |
| 825 - 113.6 (241.5 - 53.5) | 305 - 0 (12 - 0) | 203 (8) | 250 (10) |

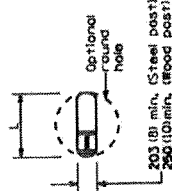

PLAN

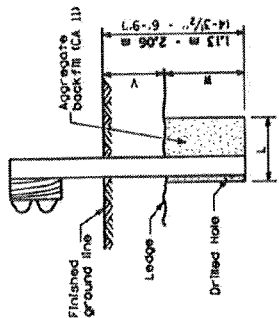

ELEVATION

Notes:
Ledge line is top of rock ledge or hard slag fill.

FOOTING FOR POST WHEN IMPERVIOUS MATERIAL IS ENCOUNTERED

STEEL PLATE BEAM GUARDRAIL

VARIOUS ROUTES
SECTION DIST 8 GUARDRAIL 2013-1
VARIOUS COUNTIES

PLOT DATE: 3/27/2012

This detail is applicable to the guardrail system used prior to January 1, 2007. For details on the Midwest Guardrail System, see Standard 530001.

| | |
|----------------------|-----------|
| TOTAL SHEETS | SHEET NO. |
| 17 | 17 |
| CONTRACT NO. 4 76F72 | |

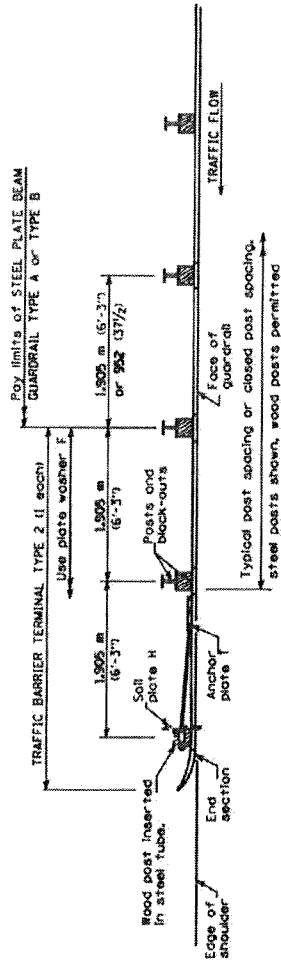

PLAN

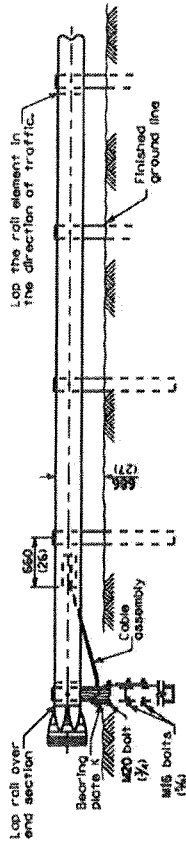

ELEVATION

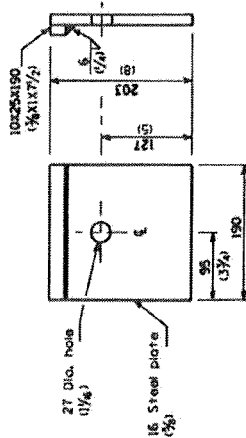

BEARING PLATE K

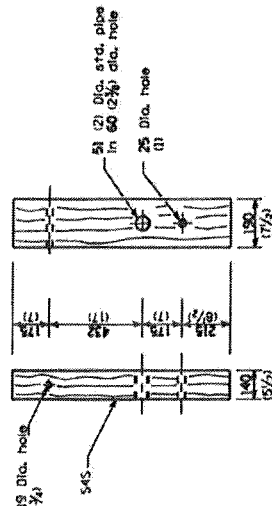

WOOD POST

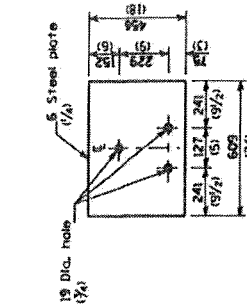

SOIL PLATE H

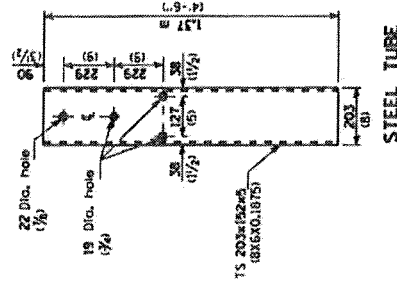

STEEL TUBE

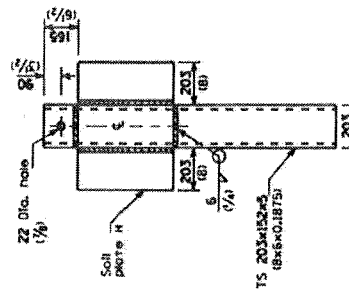

ALTERNATE SOIL PLATE CONNECTION

GENERAL NOTES

Use plate washer F at all posts.

The bearing plate K shall be held in position by (2) two eight penny nails driven into the post and bent over the top of the plate.

All dimensions are in millimeters (inches) unless otherwise shown.

TRAFFIC BARRIER TERMINAL TYPE 2

VARIOUS ROUTES
SECTION DIST 8 GUARDRAIL 2013-1
VARIOUS COUNTIES

PLOT DATE: 3/27/2012

This detail is applicable to the guardrail system used prior to January 1, 2007. For details on the Midwest Guardrail System, see Standard 630001.

ILLINOIS DEPARTMENT OF LABOR

**PREVAILING WAGES FOR
J5 F-CI G'COUNT-9G
EFFECTIVE MAY 2012**

The Prevailing rates of wages are included in the Contract proposals which are subject to Check Sheet #5 of the Supplemental Specifications and Recurring Special Provisions. The rates have been ascertained and certified by the Illinois Department of Labor for the locality in which the work is to be performed and for each craft or type of work or mechanic needed to execute the work of the Contract. As required by Prevailing Wage Act (820 ILCS 130/0.01, et seq.) and Check Sheet #5 of the Contract, not less than the rates of wages ascertained by the Illinois Department of Labor and as revised during the performance of a Contract shall be paid to all laborers, workers and mechanics performing work under the Contract. Post the scale of wages in a prominent and easily accessible place at the site of work.

If the Illinois Department of Labor revises the prevailing rates of wages to be paid as listed in the specification of rates, the contractor shall post the revised rates of wages and shall pay not less than the revised rates of wages. Current wage rate information shall be obtained by visiting the Illinois Department of Labor web site at <http://www.state.il.us/agency/idol/> or by calling 312-793-2814. It is the responsibility of the contractor to review the rates applicable to the work of the contract at regular intervals in order to insure the timely payment of current rates. Provision of this information to the contractor by means of the Illinois Department of Labor web site satisfies the notification of revisions by the Department to the contractor pursuant to the Act, and the contractor agrees that no additional notice is required. The contractor shall notify each of its subcontractors of the revised rates of wages.

Bond County Prevailing Wage for May 2012

(See explanation of column headings at bottom of wages)

| Trade Name | RG | TYP | C | Base | FRMAN | *M-F>8 | OSA | OSH | H/W | Pensn | Vac | Trng |
|----------------------|----|-------|---|--------|--------|--------|-----|-----|-------|-------|-------|-------|
| ===== | == | === | = | ===== | ===== | ===== | === | === | ===== | ===== | ===== | ===== |
| ASBESTOS ABT-GEN | | ALL | | 25.510 | 26.010 | 1.5 | 1.5 | 2.0 | 5.750 | 13.44 | 0.000 | 0.800 |
| ASBESTOS ABT-MEC | | BLD | | 29.160 | 30.160 | 1.5 | 1.5 | 2.0 | 6.700 | 2.750 | 0.000 | 0.000 |
| BOILERMAKER | | BLD | | 31.500 | 34.000 | 1.5 | 1.5 | 2.0 | 7.070 | 18.73 | 1.000 | 0.350 |
| BRICK MASON | | BLD | | 28.790 | 30.640 | 1.5 | 1.5 | 2.0 | 7.500 | 9.430 | 2.000 | 0.400 |
| CARPENTER | | ALL | | 33.880 | 35.380 | 1.5 | 1.5 | 2.0 | 6.300 | 6.250 | 0.000 | 0.400 |
| CEMENT MASON | | ALL | | 31.000 | 32.000 | 1.5 | 1.5 | 2.0 | 8.750 | 11.00 | 0.000 | 0.200 |
| CERAMIC TILE FNSHER | | BLD | | 25.520 | 0.000 | 1.5 | 1.5 | 2.0 | 5.900 | 5.110 | 0.000 | 0.470 |
| ELECTRIC PWR EQMT OP | | ALL | | 34.800 | 0.000 | 1.5 | 2.0 | 2.0 | 5.850 | 9.750 | 0.000 | 0.260 |
| ELECTRIC PWR GRNDMAN | | ALL | | 25.980 | 0.000 | 1.5 | 2.0 | 2.0 | 4.370 | 7.280 | 0.000 | 0.190 |
| ELECTRIC PWR LINEMAN | | ALL | | 40.020 | 41.950 | 1.5 | 2.0 | 2.0 | 6.720 | 11.21 | 0.000 | 0.300 |
| ELECTRIC PWR TRK DRV | | ALL | | 28.410 | 0.000 | 1.5 | 2.0 | 2.0 | 4.780 | 7.950 | 0.000 | 0.210 |
| ELECTRICIAN | E | ALL | | 37.930 | 40.180 | 1.5 | 1.5 | 2.0 | 5.350 | 9.110 | 0.000 | 0.760 |
| ELECTRICIAN | W | ALL | | 36.510 | 38.700 | 1.5 | 1.5 | 2.0 | 7.210 | 7.490 | 0.000 | 0.640 |
| ELECTRONIC SYS TECH | E | BLD | | 31.870 | 33.620 | 1.5 | 1.5 | 2.0 | 5.350 | 4.150 | 0.000 | 0.400 |
| ELECTRONIC SYS TECH | W | BLD | | 29.920 | 31.670 | 1.5 | 1.5 | 2.0 | 3.200 | 7.400 | 0.000 | 0.250 |
| ELEVATOR CONSTRUCTOR | | BLD | | 43.345 | 48.760 | 2.0 | 2.0 | 2.0 | 11.03 | 11.96 | 2.600 | 0.000 |
| FLOOR LAYER | | BLD | | 29.080 | 29.830 | 1.5 | 1.5 | 2.0 | 6.300 | 6.250 | 0.000 | 0.400 |
| GLAZIER | | BLD | | 32.780 | 0.000 | 2.0 | 2.0 | 2.0 | 9.020 | 10.80 | 2.630 | 0.310 |
| HT/FROST INSULATOR | | BLD | | 36.760 | 37.760 | 1.5 | 1.5 | 2.0 | 7.550 | 10.76 | 0.000 | 0.500 |
| IRON WORKER | | ALL | | 31.000 | 33.000 | 1.5 | 1.5 | 2.0 | 7.110 | 12.35 | 0.000 | 0.420 |
| LABORER | | ALL | | 25.010 | 25.510 | 1.5 | 1.5 | 2.0 | 5.750 | 13.44 | 0.000 | 0.800 |
| MACHINIST | | BLD | | 43.160 | 45.160 | 1.5 | 1.5 | 2.0 | 7.980 | 8.950 | 0.000 | 0.000 |
| MARBLE FINISHERS | | BLD | | 25.520 | 0.000 | 1.5 | 1.5 | 2.0 | 5.900 | 5.110 | 0.000 | 0.470 |
| MARBLE MASON | | BLD | | 28.790 | 30.640 | 1.5 | 1.5 | 2.0 | 7.500 | 9.430 | 2.000 | 0.400 |
| MILLWRIGHT | | ALL | | 33.880 | 35.380 | 1.5 | 1.5 | 2.0 | 6.300 | 6.250 | 0.000 | 0.400 |
| OPERATING ENGINEER | | BLD 1 | | 33.650 | 36.650 | 1.5 | 1.5 | 2.0 | 8.400 | 16.50 | 0.000 | 1.000 |
| OPERATING ENGINEER | | BLD 2 | | 32.520 | 36.650 | 1.5 | 1.5 | 2.0 | 8.400 | 16.50 | 0.000 | 1.000 |
| OPERATING ENGINEER | | BLD 3 | | 28.040 | 36.650 | 1.5 | 1.5 | 2.0 | 8.400 | 16.50 | 0.000 | 1.000 |
| OPERATING ENGINEER | | BLD 4 | | 28.100 | 36.650 | 1.5 | 1.5 | 2.0 | 8.400 | 16.50 | 0.000 | 1.000 |
| OPERATING ENGINEER | | BLD 5 | | 27.770 | 36.650 | 1.5 | 1.5 | 2.0 | 8.400 | 16.50 | 0.000 | 1.000 |
| OPERATING ENGINEER | | BLD 6 | | 34.200 | 36.650 | 1.5 | 1.5 | 2.0 | 8.400 | 16.50 | 0.000 | 1.000 |
| OPERATING ENGINEER | | BLD 7 | | 34.500 | 36.650 | 1.5 | 1.5 | 2.0 | 8.400 | 16.50 | 0.000 | 1.000 |
| OPERATING ENGINEER | | BLD 8 | | 34.780 | 36.650 | 1.5 | 1.5 | 2.0 | 8.400 | 16.50 | 0.000 | 1.000 |
| OPERATING ENGINEER | | BLD 9 | | 35.650 | 36.650 | 1.5 | 1.5 | 2.0 | 8.400 | 16.50 | 0.000 | 1.000 |
| OPERATING ENGINEER | | HWY 1 | | 32.150 | 35.150 | 1.5 | 1.5 | 2.0 | 8.400 | 16.50 | 0.000 | 1.000 |
| OPERATING ENGINEER | | HWY 2 | | 31.020 | 35.150 | 1.5 | 1.5 | 2.0 | 8.400 | 16.50 | 0.000 | 1.000 |
| OPERATING ENGINEER | | HWY 3 | | 26.540 | 35.150 | 1.5 | 1.5 | 2.0 | 8.400 | 16.50 | 0.000 | 1.000 |
| OPERATING ENGINEER | | HWY 4 | | 26.600 | 35.150 | 1.5 | 1.5 | 2.0 | 8.400 | 16.50 | 0.000 | 1.000 |
| OPERATING ENGINEER | | HWY 5 | | 26.270 | 35.150 | 1.5 | 1.5 | 2.0 | 8.400 | 16.50 | 0.000 | 1.000 |
| OPERATING ENGINEER | | HWY 6 | | 32.700 | 35.150 | 1.5 | 1.5 | 2.0 | 8.400 | 16.50 | 0.000 | 1.000 |
| OPERATING ENGINEER | | HWY 7 | | 33.000 | 35.150 | 1.5 | 1.5 | 2.0 | 8.400 | 16.50 | 0.000 | 1.000 |
| OPERATING ENGINEER | | HWY 8 | | 33.280 | 35.150 | 1.5 | 1.5 | 2.0 | 8.400 | 16.50 | 0.000 | 1.000 |
| OPERATING ENGINEER | | HWY 9 | | 34.150 | 35.150 | 1.5 | 1.5 | 2.0 | 8.400 | 16.50 | 0.000 | 1.000 |
| PAINTER | | BLD | | 29.250 | 30.750 | 1.5 | 1.5 | 2.0 | 5.000 | 7.920 | 0.000 | 0.600 |
| PAINTER | | HWY | | 30.450 | 31.950 | 1.5 | 1.5 | 2.0 | 5.000 | 7.920 | 0.000 | 0.600 |
| PAINTER OVER 30FT | | BLD | | 30.250 | 31.750 | 1.5 | 1.5 | 2.0 | 5.000 | 7.920 | 0.000 | 0.600 |
| PAINTER PWR EQMT | | BLD | | 30.250 | 31.750 | 1.5 | 1.5 | 2.0 | 5.000 | 7.920 | 0.000 | 0.600 |
| PAINTER PWR EQMT | | HWY | | 31.450 | 32.950 | 1.5 | 1.5 | 2.0 | 5.000 | 7.920 | 0.000 | 0.600 |
| PILEDRIIVER | | ALL | | 33.880 | 35.380 | 1.5 | 1.5 | 2.0 | 6.300 | 6.250 | 0.000 | 0.400 |
| PIPEFITTER | | BLD | | 35.800 | 37.590 | 2.0 | 2.0 | 2.0 | 4.400 | 8.360 | 0.000 | 0.200 |
| PLASTERER | | BLD | | 30.250 | 31.250 | 1.5 | 1.5 | 2.0 | 8.750 | 8.300 | 0.000 | 0.050 |
| PLUMBER | | BLD | | 35.800 | 37.590 | 2.0 | 2.0 | 2.0 | 4.400 | 8.360 | 0.000 | 0.200 |
| ROOFER | | BLD | | 28.650 | 30.650 | 1.5 | 1.5 | 2.0 | 8.150 | 6.650 | 0.000 | 0.200 |
| SHEETMETAL WORKER | | ALL | | 31.690 | 33.190 | 1.5 | 1.5 | 2.0 | 7.130 | 6.730 | 1.910 | 0.360 |
| SPRINKLER FITTER | | BLD | | 36.140 | 38.890 | 1.5 | 1.5 | 2.0 | 8.100 | 8.200 | 0.000 | 0.350 |
| TERRAZZO FINISHER | | BLD | | 31.240 | 0.000 | 1.5 | 1.5 | 2.0 | 5.900 | 2.730 | 0.000 | 0.130 |
| TERRAZZO MASON | | BLD | | 32.530 | 32.830 | 1.5 | 1.5 | 2.0 | 5.900 | 4.980 | 0.000 | 0.140 |

| | | | | | | | | | | | |
|--------------|-----|---|--------|-------|-----|-----|-----|-------|-------|-------|-------|
| TRUCK DRIVER | ALL | 1 | 30.460 | 0.000 | 1.5 | 1.5 | 2.0 | 10.05 | 4.775 | 0.000 | 0.250 |
| TRUCK DRIVER | ALL | 2 | 30.890 | 0.000 | 1.5 | 1.5 | 2.0 | 10.05 | 4.775 | 0.000 | 0.250 |
| TRUCK DRIVER | ALL | 3 | 31.120 | 0.000 | 1.5 | 1.5 | 2.0 | 10.05 | 4.775 | 0.000 | 0.250 |
| TRUCK DRIVER | ALL | 4 | 31.380 | 0.000 | 1.5 | 1.5 | 2.0 | 10.05 | 4.775 | 0.000 | 0.250 |
| TRUCK DRIVER | ALL | 5 | 32.200 | 0.000 | 1.5 | 1.5 | 2.0 | 10.05 | 4.775 | 0.000 | 0.250 |
| TRUCK DRIVER | O&C | 1 | 24.370 | 0.000 | 1.5 | 1.5 | 2.0 | 10.05 | 4.775 | 0.000 | 0.250 |
| TRUCK DRIVER | O&C | 2 | 24.710 | 0.000 | 1.5 | 1.5 | 2.0 | 10.05 | 4.775 | 0.000 | 0.250 |
| TRUCK DRIVER | O&C | 3 | 24.900 | 0.000 | 1.5 | 1.5 | 2.0 | 10.05 | 4.775 | 0.000 | 0.250 |
| TRUCK DRIVER | O&C | 4 | 25.100 | 0.000 | 1.5 | 1.5 | 2.0 | 10.05 | 4.775 | 0.000 | 0.250 |
| TRUCK DRIVER | O&C | 5 | 25.760 | 0.000 | 1.5 | 1.5 | 2.0 | 10.05 | 4.775 | 0.000 | 0.250 |

Legend :

RG (Region)

TYP (Trade Type - All,Highway,Building,Floating,Oil & Chip,Rivers)

C (Class)

Base (Base Wage Rate)

FRMAN (Foreman Rate)

M-F>8 (OT required for any hour greater than 8 worked each day, Mon through Fri.

OSA (Overtime (OT) is required for every hour worked on Saturday)

OSH (Overtime is required for every hour worked on Sunday and Holidays)

H/W (Health & Welfare Insurance)

Pensn (Pension)

Vac (Vacation)

Trng (Training)

Explanations

BOND COUNTY

ELECTRICIANS AND ELECTRONIC SYSTEMS TECHNICIAN (EAST) - Townships of Mulberry Grove, Pleasant Mount & Tamalco.

ELECTRICIANS AND ELECTRONIC SYSTEMS TECHNICIAN (WEST) - Townships of Shoal Creek, LaGrange, Old Ripley, Central, Burgess & Mills

The following list is considered as those days for which holiday rates of wages for work performed apply: New Years Day, Memorial Day, Fourth of July, Labor Day, Thanksgiving Day, Christmas Day and Veterans Day in some classifications/counties. Generally, any of these holidays which fall on a Sunday is celebrated on the following

Monday. This then makes work performed on that Monday payable at the appropriate overtime rate for holiday pay. Common practice in a given local may alter certain days of celebration. If in doubt, please check with IDOL.

Oil and chip resealing (O&C) means the application of road oils and liquid asphalt to coat an existing road surface, followed by application of aggregate chips or gravel to coated surface, and subsequent rolling of material to seal the surface.

EXPLANATION OF CLASSES

ASBESTOS - GENERAL - removal of asbestos material/mold and hazardous materials from any place in a building, including mechanical systems where those mechanical systems are to be removed. This includes the removal of asbestos materials/mold and hazardous materials from ductwork or pipes in a building when the building is to be demolished at the time or at some close future date.

ASBESTOS - MECHANICAL - removal of asbestos material from mechanical systems, such as pipes, ducts, and boilers, where the mechanical systems are to remain.

CERAMIC TILE FINISHER AND MARBLE FINISHER

The handling, at the building site, of all sand, cement, tile, marble or stone and all other materials that may be used and installed by [a] tile layer or marble mason. In addition, the grouting, cleaning, sealing, and mixing on the job site, and all other work as required in assisting the setter. The term "Ceramic" is used for naming the classification only and is in no way a limitation of the product handled. Ceramic takes into consideration most hard tiles.

ELECTRONIC SYSTEMS TECHNICIAN

Installation, service and maintenance of low-voltage systems which utilizes the transmission and/or transference of voice, sound, vision, or digital for commercial, education, security and entertainment purposes for the following: TV monitoring and surveillance, background/foreground music, intercom and telephone interconnect, field programming, inventory control systems, microwave transmission, multi-media, multiplex, radio page, school, intercom and sound burglar alarms and low voltage master clock systems.

Excluded from this classification are energy management systems, life safety systems, supervisory controls and data acquisition systems not intrinsic with the above listed systems, fire alarm systems, nurse call systems and raceways exceeding fifteen feet in length.

OPERATING ENGINEER - BUILDING

GROUP I. Cranes, Dragline, Shovels, Skimmer Scoops, Clamshells or Derrick Boats, Pile Drivers, Crane-Type Backhoes, Asphalt Plant Operators, Concrete Plant Operators, Dredges, Asphalt Spreading Machines, All Locomotives, Cable Ways or Tower Machines, Hoists, Hydraulic Backhoes, Ditching Machines or Backfiller, Cherrypickers, Overhead Cranes, Roller - Steam or Gas, Concrete Pavers, Excavators, Concrete Breakers, Concrete Pumps, Bulk Cement Plants, Cement Pumps, Derrick-Type Drills, Boat Operators, Motor Graders or Pushcats, Scoops or Tournapulls, Bulldozers, Endloaders or Fork Lifts, Power Blade or Elevating Graders, Winch Cats, Boom or Winch Trucks or Boom Tractors, Pipe Wrapping or Painting Machines, Asphalt Plant Engineer, Journeyman Lubricating Engineer, Drills (other than Derrick Type), Mud Jacks, or

Well Drilling Machines, Boring Machines or Track Jacks, Mixers, Conveyors (Two), Air Compressors (Two), Water Pumps regardless of size (Two), Welding Machines (Two), Siphons or Jets (Two), Winch Heads or Apparatuses (Two), Light Plants (Two), All Tractors regardless of size (straight tractor only), Fireman on Stationary Boilers, Automatic Elevators, Form Grading Machines, Finishing Machines, Power Sub-Grader or Ribbon Machines, Longitudinal Floats, Distributor Operators on Trucks, Winch Heads or Apparatuses (One), Mobil Track air and heaters (two to five), Heavy Equipment Greaser, Relief Operator, Assistant Master Mechanic and Heavy Duty Mechanic, self-propelled concrete saws of all types and sizes with their attachments, gob-hoppers, excavators all sizes, the repair and greasing of all diesel hammers, the operation and set-up of bidwells, water blasters of all sizes and their clutches, hydraulic jacks where used for hoisting, operation of log skidders, iceolators used on and off of pipeline, condor cranes, bow boats, survey boats, bobcats and all their attachments, skid steer loaders and all their attachments, creter cranes, batch plants, operator (all sizes), self propelled roto mills, operation of conveyor systems of any size and any configuration, operation, repair and service of all vibratory hammers, all power pacs and their controls regardless of location, curtains or brush burning machines, stump cutter machines, Nail launchers when mounted on a machine or self-propelled, operation of con-cover machines, and all Operators except those listed below).

GROUP II. Assistant Operators.

GROUP III. Air Compressors (One), Water Pumps, regardless of Size (One), Waterblasters (one), Welding Machine (One), Mixers (One Bag), Conveyor (One), Siphon or Jet (One), Light Plant (One), Heater (One), Immobile Track Air (One), and Self Propelled Walk-Behind Rollers.

GROUP IV. Asphalt Spreader Oilers, Fireman on Whirlies and Heavy Equipment Oilers, Truck Cranes, Dredges, Monigans, Large Cranes - (Over 65-ton rated capacity) Concrete Plant Oiler, Blacktop Plant Oiler, and Creter Crane Oiler (when required).

GROUP V. Oiler.

GROUP VI. Operators on equipment with Booms, including jibs, 100 feet and over, and less than 150 feet long.

GROUP VII. Operators on equipment with Booms, including jibs, 150 feet and over, and less than 200 feet long.

GROUP VIII. Operators on Equipment with Booms, including jibs, 200 feet and over; Tower Cranes; and Whirlie Cranes.

GROUP IX. Master Mechanic

OPERATING ENGINEERS - Highway

GROUP I. Cranes, Dragline, Shovels, Skimmer Scoops, Clamshells or Derrick Boats, Pile Drivers, Crane-Type Backhoes, Asphalt Plant Operators, Concrete Plant Operators, Dredges, Asphalt Spreading Machines, All Locomotives, Cable Ways or Tower Machines, Hoists, Hydraulic Backhoes, Ditching Machines or Backfiller, Cherrypickers, Overhead Cranes, Roller - Steam or Gas, Concrete Pavers, Excavators, Concrete Breakers, Concrete Pumps, Bulk Cement Plants, Cement Pumps, Derrick-Type Drills, Boat Operators, Motor Graders or Pushcats, Scoops or Tournapulls, Bulldozers, Endloaders or Fork Lifts, Power Blade or Elevating Graders, Winch Cats, Boom or Winch Trucks or Boom Tractors, Pipe Wrapping or Painting Machines, Asphalt Plant Engineer, Journeyman

Lubricating Engineer, Drills (other than Derrick Type), Mud Jacks, Well Drilling Machines, Boring Machines, Track Jacks, Mixers, Conveyors (Two), Air Compressors (Two), Water Pumps regardless of size (Two), Welding Machines (Two), Siphons or Jets (Two), Winch Heads or Apparatuses (Two), Light Plants (Two), All Tractors regardless of size (straight tractor only), Fireman on Stationary Boilers, Automatic Elevators, Form Grading Machines, Finishing Machines, Power Sub-Grader or Ribbon Machines, Longitudinal Floats, Distributor Operators on Trucks, Winch Heads or Apparatuses (One), Mobil Track air and heaters (two to five), Heavy Equipment Greaser, Relief Operator, Assistant Master Mechanic and Heavy Duty Mechanic, self-propelled concrete saws of all types and sizes with their attachments, gob-hoppers, excavators all sizes, the repair and greasing of all diesel hammers, the operation and set-up of bidwells, water blasters of all sizes and their clutches, hydraulic jacks where used for hoisting, operation of log skidders, iceolators used on and off of pipeline, condor cranes, bow boats, survey boats, bobcats and all their attachments, skid steer loaders and all their attachments, creter cranes, batch plants, operator (all sizes), self propelled roto mills, operation of conveyor systems of any size and any configuration, operation, repair and service of all vibratory hammers, all power pacs and their controls regardless of location, curtains or brush burning machines, stump cutter machines, Nail launchers when mounted on a machine or self-propelled, operation of con-cover machines, and all Operators (except those listed below).

GROUP II. Assistant Operators.

GROUP III. Air Compressors (One), Water Pumps, regardless of Size (One), Waterblasters (one), Welding Machine (One), Mixers (One Bag), Conveyor (One), Siphon or Jet (One), Light Plant (One), Heater (One), Immobile Track Air (One), and Self Propelled Walk-Behind Rollers.

GROUP IV. Asphalt Spreader Oilers, Fireman on Whirlies and Heavy Equipment Oilers, Truck Cranes, Dredges, Monigans, Large Cranes - (Over 65-ton rated capacity) Concrete Plant Oiler, Blacktop Plant Oiler, and Creter Crane Oiler (when required).

GROUP V. Oiler.

GROUP VI. Operators on equipment with Booms, including jibs, 100 feet and over, and less than 150 feet long.

GROUP VII. Operators on equipment with Booms, including jibs, 150 feet and over, and less than 200 feet long.

GROUP VIII. Operators on Equipment with Booms, including jibs, 200 feet and over; Tower Cranes; and Whirlie Cranes.

GROUP IX. Mechanic

TRUCK DRIVER - BUILDING, HEAVY AND HIGHWAY CONSTRUCTION

Class 1. Drivers on 2 axle trucks hauling less than 9 ton. Air compressor and welding machines and brooms, including those pulled by separate units, truck driver helpers, warehouse employees, mechanic helpers, greasers and tiremen, pickup trucks when hauling materials, tools, or workers to and from and on-the-job site, and fork lifts up to 6,000 lb. capacity.

Class 2. Two or three axle trucks hauling more than 9 ton but hauling less than 16 ton. A-frame winch trucks, hydrolift trucks, vactor

trucks or similar equipment when used for transportation purposes. Fork lifts over 6,000 lb. capacity, winch trucks, four axle combination units, and ticket writers.

Class 3. Two, three or four axle trucks hauling 16 ton or more. Drivers on water pulls, articulated dump trucks, mechanics and working forepersons, and dispatchers. Five axle or more combination units.

Class 4. Low Boy and Oil Distributors.

Class 5. Drivers who require special protective clothing while employed on hazardous waste work.

TRUCK DRIVER - OIL AND CHIP RESEALING ONLY.

This shall encompass laborers, workers and mechanics who drive contractor or subcontractor owned, leased, or hired pickup, dump, service, or oil distributor trucks. The work includes transporting materials and equipment (including but not limited to, oils, aggregate supplies, parts, machinery and tools) to or from the job site; distributing oil or liquid asphalt and aggregate; stock piling material when in connection with the actual oil and chip contract. The Truck Driver (Oil & Chip Resealing) wage classification does not include supplier delivered materials.

TERRAZZO FINISHER

The handling of all materials used for Mosaic and Terrazzo work including preparing, mixing by hand, by mixing machine or transporting of pre-mixed materials and distributing with shovel, rake, hoe, or pail, all kinds of concrete foundations necessary for Mosaic and Terrazzo work, all cement terrazzo, magnesite terrazzo, Do-O-Tex terrazzo, epoxy matrix ter-razzo, exposed aggregate, rustic or rough washed for exterior or interior of buildings placed either by machine or by hand, and any other kind of mixture of plastics composed of chips or granules when mixed with cement, rubber, neoprene, vinyl, magnesium chloride or any other resinous or chemical substances used for seamless flooring systems, and all other building materials, all similar materials and all precast terrazzo work on jobs, all scratch coat used for Mosaic and Terrazzo work and sub-bed, tar paper and wire mesh (2x2 etc.) or lath. The rubbing, grinding, cleaning and finishing of same either by hand or by machine or by terrazzo resurfacing equipment on new or existing floors. When necessary finishers shall be allowed to assist the mechanics to spread sand bed, lay tarpaper and wire mesh (2x2 etc.) or lath. The finishing of cement floors where additional aggregate of stone is added by spreading or sprinkling on top of the finished base, and troweled or rolled into the finish and then the surface is ground by grinding machines.

Other Classifications of Work:

For definitions of classifications not otherwise set out, the Department generally has on file such definitions which are available. If a task to be performed is not subject to one of the classifications of pay set out, the Department will upon being contacted state which neighboring county has such a classification and provide such rate, such rate being deemed to exist by reference in this document. If no neighboring county rate applies to the task, the Department shall undertake a special determination, such special determination being then deemed to have existed under this

determination. If a project requires these, or any classification not listed, please contact IDOL at 217-782-1710 for wage rates or clarifications.

LANDSCAPING

Landscaping work falls under the existing classifications for laborer, operating engineer and truck driver. The work performed by landscape plantsman and landscape laborer is covered by the existing classification of laborer. The work performed by landscape operators (regardless of equipment used or its size) is covered by the classifications of operating engineer. The work performed by landscape truck drivers (regardless of size of truck driven) is covered by the classifications of truck driver.

Calhoun County Prevailing Wage for May 2012

(See explanation of column headings at bottom of wages)

| Trade Name | RG | TYP | C | Base | FRMAN | *M-F>8 | OSA | OSH | H/W | Pensn | Vac | Trng |
|----------------------|----|-----|---|--------|--------|--------|-----|-----|-------|-------|-------|-------|
| ===== | == | === | = | ===== | ===== | ===== | === | === | ===== | ===== | ===== | ===== |
| ASBESTOS ABT-GEN | | ALL | | 29.510 | 30.010 | 1.5 | 1.5 | 2.0 | 5.750 | 9.440 | 0.000 | 0.800 |
| ASBESTOS ABT-MEC | | BLD | | 29.160 | 30.160 | 1.5 | 1.5 | 2.0 | 6.700 | 2.750 | 0.000 | 0.000 |
| BOILERMAKER | | BLD | | 31.500 | 34.000 | 1.5 | 1.5 | 2.0 | 7.070 | 18.73 | 1.000 | 0.350 |
| BRICK MASON | | BLD | | 28.790 | 30.640 | 1.5 | 1.5 | 2.0 | 7.500 | 9.430 | 2.000 | 0.400 |
| CARPENTER | | ALL | | 33.880 | 35.380 | 1.5 | 1.5 | 2.0 | 6.300 | 6.250 | 0.000 | 0.400 |
| CEMENT MASON | | ALL | | 31.000 | 32.000 | 1.5 | 1.5 | 2.0 | 8.750 | 11.00 | 0.000 | 0.200 |
| CERAMIC TILE FNSHER | | BLD | | 25.520 | 0.000 | 1.5 | 1.5 | 2.0 | 5.900 | 5.110 | 0.000 | 0.470 |
| ELECTRIC PWR EQMT OP | | ALL | | 36.690 | 44.520 | 1.5 | 2.0 | 2.0 | 5.000 | 9.170 | 0.000 | 0.280 |
| ELECTRIC PWR GRNDMAN | | ALL | | 24.940 | 44.520 | 1.5 | 2.0 | 2.0 | 5.000 | 6.240 | 0.000 | 0.190 |
| ELECTRIC PWR LINEMAN | | ALL | | 42.210 | 44.520 | 1.5 | 2.0 | 2.0 | 5.000 | 10.56 | 0.000 | 0.320 |
| ELECTRIC PWR TRK DRV | | ALL | | 25.560 | 44.520 | 1.5 | 2.0 | 2.0 | 5.000 | 6.390 | 0.000 | 0.190 |
| ELECTRICIAN | | ALL | | 36.400 | 38.650 | 1.5 | 1.5 | 2.0 | 7.500 | 9.090 | 0.000 | 0.550 |
| ELECTRONIC SYS TECH | | BLD | | 28.740 | 30.490 | 1.5 | 1.5 | 2.0 | 7.500 | 5.860 | 0.000 | 0.400 |
| FLOOR LAYER | | BLD | | 29.080 | 29.830 | 1.5 | 1.5 | 2.0 | 6.300 | 6.250 | 0.000 | 0.400 |
| GLAZIER | | BLD | | 32.780 | 0.000 | 2.0 | 2.0 | 2.0 | 9.020 | 10.80 | 2.630 | 0.310 |
| HT/FROST INSULATOR | | BLD | | 36.760 | 37.760 | 1.5 | 1.5 | 2.0 | 7.550 | 10.76 | 0.000 | 0.500 |
| IRON WORKER | | ALL | | 31.000 | 33.000 | 1.5 | 1.5 | 2.0 | 7.110 | 12.35 | 0.000 | 0.420 |
| LABORER | | ALL | | 29.010 | 29.510 | 1.5 | 1.5 | 2.0 | 5.750 | 9.440 | 0.000 | 0.800 |
| MACHINIST | | BLD | | 43.160 | 45.160 | 1.5 | 1.5 | 2.0 | 7.980 | 8.950 | 0.000 | 0.000 |
| MARBLE FINISHERS | | BLD | | 25.520 | 0.000 | 1.5 | 1.5 | 2.0 | 5.900 | 5.110 | 0.000 | 0.470 |
| MILLWRIGHT | | ALL | | 33.880 | 35.380 | 1.5 | 1.5 | 2.0 | 6.300 | 6.250 | 0.000 | 0.400 |
| OPERATING ENGINEER | | BLD | 1 | 33.650 | 36.650 | 1.5 | 1.5 | 2.0 | 8.400 | 16.50 | 0.000 | 1.000 |
| OPERATING ENGINEER | | BLD | 2 | 32.520 | 36.650 | 1.5 | 1.5 | 2.0 | 8.400 | 16.50 | 0.000 | 1.000 |
| OPERATING ENGINEER | | BLD | 3 | 28.040 | 36.650 | 1.5 | 1.5 | 2.0 | 8.400 | 16.50 | 0.000 | 1.000 |
| OPERATING ENGINEER | | BLD | 4 | 28.100 | 36.650 | 1.5 | 1.5 | 2.0 | 8.400 | 16.50 | 0.000 | 1.000 |
| OPERATING ENGINEER | | BLD | 5 | 27.770 | 36.650 | 1.5 | 1.5 | 2.0 | 8.400 | 16.50 | 0.000 | 1.000 |
| OPERATING ENGINEER | | BLD | 6 | 34.200 | 36.650 | 1.5 | 1.5 | 2.0 | 8.400 | 16.50 | 0.000 | 1.000 |
| OPERATING ENGINEER | | BLD | 7 | 34.500 | 36.650 | 1.5 | 1.5 | 2.0 | 8.400 | 16.50 | 0.000 | 1.000 |
| OPERATING ENGINEER | | BLD | 8 | 34.780 | 36.650 | 1.5 | 1.5 | 2.0 | 8.400 | 16.50 | 0.000 | 1.000 |
| OPERATING ENGINEER | | BLD | 9 | 35.650 | 36.650 | 1.5 | 1.5 | 2.0 | 8.400 | 16.50 | 0.000 | 1.000 |
| OPERATING ENGINEER | | HWY | 1 | 32.150 | 35.150 | 1.5 | 1.5 | 2.0 | 8.400 | 16.50 | 0.000 | 1.000 |
| OPERATING ENGINEER | | HWY | 2 | 31.020 | 35.150 | 1.5 | 1.5 | 2.0 | 8.400 | 16.50 | 0.000 | 1.000 |
| OPERATING ENGINEER | | HWY | 3 | 26.540 | 35.150 | 1.5 | 1.5 | 2.0 | 8.400 | 16.50 | 0.000 | 1.000 |
| OPERATING ENGINEER | | HWY | 4 | 26.600 | 35.150 | 1.5 | 1.5 | 2.0 | 8.400 | 16.50 | 0.000 | 1.000 |
| OPERATING ENGINEER | | HWY | 5 | 26.270 | 35.150 | 1.5 | 1.5 | 2.0 | 8.400 | 16.50 | 0.000 | 1.000 |
| OPERATING ENGINEER | | HWY | 6 | 32.700 | 35.150 | 1.5 | 1.5 | 2.0 | 8.400 | 16.50 | 0.000 | 1.000 |
| OPERATING ENGINEER | | HWY | 7 | 33.000 | 35.150 | 1.5 | 1.5 | 2.0 | 8.400 | 16.50 | 0.000 | 1.000 |
| OPERATING ENGINEER | | HWY | 8 | 33.280 | 35.150 | 1.5 | 1.5 | 2.0 | 8.400 | 16.50 | 0.000 | 1.000 |
| OPERATING ENGINEER | | HWY | 9 | 34.150 | 35.150 | 1.5 | 1.5 | 2.0 | 8.400 | 16.50 | 0.000 | 1.000 |
| PAINTER | | BLD | | 29.250 | 30.750 | 1.5 | 1.5 | 2.0 | 5.000 | 7.920 | 0.000 | 0.600 |
| PAINTER | | HWY | | 30.450 | 31.950 | 1.5 | 1.5 | 2.0 | 5.000 | 7.920 | 0.000 | 0.600 |
| PAINTER OVER 30FT | | BLD | | 30.250 | 31.750 | 1.5 | 1.5 | 2.0 | 5.000 | 7.920 | 0.000 | 0.600 |
| PAINTER PWR EQMT | | BLD | | 30.250 | 31.750 | 1.5 | 1.5 | 2.0 | 5.000 | 7.920 | 0.000 | 0.600 |
| PAINTER PWR EQMT | | HWY | | 31.450 | 32.950 | 1.5 | 1.5 | 2.0 | 5.000 | 7.920 | 0.000 | 0.600 |
| PILEDRIVER | | ALL | | 33.880 | 35.380 | 1.5 | 1.5 | 2.0 | 6.300 | 6.250 | 0.000 | 0.400 |
| PIPEFITTER | | BLD | | 35.800 | 37.590 | 2.0 | 2.0 | 2.0 | 4.400 | 8.360 | 0.000 | 0.200 |
| PLASTERER | | BLD | | 30.250 | 31.250 | 1.5 | 1.5 | 2.0 | 8.750 | 8.300 | 0.000 | 0.050 |
| PLUMBER | | BLD | | 35.800 | 37.590 | 2.0 | 2.0 | 2.0 | 4.400 | 8.360 | 0.000 | 0.200 |
| ROOFER | | BLD | | 28.650 | 30.650 | 1.5 | 1.5 | 2.0 | 8.150 | 6.650 | 0.000 | 0.200 |
| SHEETMETAL WORKER | | BLD | | 25.770 | 27.530 | 1.5 | 1.5 | 2.0 | 7.140 | 8.840 | 0.000 | 0.540 |
| SPRINKLER FITTER | | BLD | | 37.830 | 40.830 | 2.0 | 2.0 | 2.0 | 8.550 | 10.35 | 0.000 | 0.850 |
| TERRAZZO FINISHER | | BLD | | 31.240 | 0.000 | 1.5 | 1.5 | 2.0 | 5.900 | 2.730 | 0.000 | 0.130 |
| TERRAZZO MASON | | BLD | | 32.530 | 32.830 | 1.5 | 1.5 | 2.0 | 5.900 | 4.980 | 0.000 | 0.140 |
| TRUCK DRIVER | | ALL | 1 | 30.460 | 0.000 | 1.5 | 1.5 | 2.0 | 10.05 | 4.775 | 0.000 | 0.250 |
| TRUCK DRIVER | | ALL | 2 | 30.890 | 0.000 | 1.5 | 1.5 | 2.0 | 10.05 | 4.775 | 0.000 | 0.250 |
| TRUCK DRIVER | | ALL | 3 | 31.120 | 0.000 | 1.5 | 1.5 | 2.0 | 10.05 | 4.775 | 0.000 | 0.250 |
| TRUCK DRIVER | | ALL | 4 | 31.380 | 0.000 | 1.5 | 1.5 | 2.0 | 10.05 | 4.775 | 0.000 | 0.250 |

| | | | | | | | | | | | |
|--------------|-----|---|--------|-------|-----|-----|-----|-------|-------|-------|-------|
| TRUCK DRIVER | ALL | 5 | 32.200 | 0.000 | 1.5 | 1.5 | 2.0 | 10.05 | 4.775 | 0.000 | 0.250 |
| TRUCK DRIVER | O&C | 1 | 24.370 | 0.000 | 1.5 | 1.5 | 2.0 | 10.05 | 4.775 | 0.000 | 0.250 |
| TRUCK DRIVER | O&C | 2 | 24.710 | 0.000 | 1.5 | 1.5 | 2.0 | 10.05 | 4.775 | 0.000 | 0.250 |
| TRUCK DRIVER | O&C | 3 | 24.900 | 0.000 | 1.5 | 1.5 | 2.0 | 10.05 | 4.775 | 0.000 | 0.250 |
| TRUCK DRIVER | O&C | 4 | 25.100 | 0.000 | 1.5 | 1.5 | 2.0 | 10.05 | 4.775 | 0.000 | 0.250 |
| TRUCK DRIVER | O&C | 5 | 25.760 | 0.000 | 1.5 | 1.5 | 2.0 | 10.05 | 4.775 | 0.000 | 0.250 |

Legend:

RG (Region)

TYP (Trade Type - All,Highway,Building,Floating,Oil & Chip,Rivers)

C (Class)

Base (Base Wage Rate)

FRMAN (Foreman Rate)

M-F>8 (OT required for any hour greater than 8 worked each day, Mon through Fri.

OSA (Overtime (OT) is required for every hour worked on Saturday)

OSH (Overtime is required for every hour worked on Sunday and Holidays)

H/W (Health & Welfare Insurance)

Pensn (Pension)

Vac (Vacation)

Trng (Training)

Explanations

CALHOUN COUNTY

The following list is considered as those days for which holiday rates of wages for work performed apply: New Years Day, Memorial Day, Fourth of July, Labor Day, Thanksgiving Day, Christmas Day and Veterans Day in some classifications/counties. Generally, any of these holidays which fall on a Sunday is celebrated on the following Monday. This then makes work performed on that Monday payable at the appropriate overtime rate for holiday pay. Common practice in a given local may alter certain days of celebration. If in doubt, please check with IDOL.

Oil and chip resealing (O&C) means the application of road oils and liquid asphalt to coat an existing road surface, followed by application of aggregate chips or gravel to coated surface, and subsequent rolling of material to seal the surface.

EXPLANATION OF CLASSES

ASBESTOS - GENERAL - removal of asbestos material/mold and hazardous materials from any place in a building, including mechanical systems where those mechanical systems are to be removed. This includes the removal of asbestos materials/mold and hazardous materials from ductwork or pipes in a building when the building is to be demolished at the time or at some close future date.

ASBESTOS - MECHANICAL - removal of asbestos material from mechanical systems, such as pipes, ducts, and boilers, where the mechanical systems are to remain.

CERAMIC TILE FINISHER AND MARBLE FINISHER

The handling, at the building site, of all sand, cement, tile, marble or stone and all other materials that may be used and installed by [a] tile layer or marble mason. In addition, the grouting, cleaning, sealing, and mixing on the job site, and all other work as required in assisting the setter. The term "Ceramic" is used for naming the classification only and is in no way a limitation of the product handled. Ceramic takes into consideration most hard tiles.

ELECTRONIC SYSTEMS TECHNICIAN

Installation, service and maintenance of low-voltage systems which utilizes the transmission and/or transference of voice, sound, vision, or digital for commercial, education, security and entertainment purposes for the following: TV monitoring and surveillance, background/foreground music, intercom and telephone interconnect, field programming, inventory control systems, microwave transmission, multi-media, multiplex, radio page, school, intercom and sound burglar alarms and low voltage master clock systems.

Excluded from this classification are energy management systems, life safety systems, supervisory controls and data acquisition systems not intrinsic with the above listed systems, fire alarm systems, nurse call systems and raceways exceeding fifteen feet in length.

OPERATING ENGINEER - BUILDING

GROUP I. Cranes, Dragline, Shovels, Skimmer Scoops, Clamshells or Derrick Boats, Pile Drivers, Crane-Type Backhoes, Asphalt Plant Operators, Concrete Plant Operators, Dredges, Asphalt Spreading Machines, All Locomotives, Cable Ways or Tower Machines, Hoists, Hydraulic Backhoes, Ditching Machines or Backfiller, Cherrypickers, Overhead Cranes, Roller - Steam or Gas, Concrete Pavers, Excavators, Concrete Breakers, Concrete Pumps, Bulk Cement Plants, Cement Pumps, Derrick-Type Drills, Boat Operators, Motor Graders or Pushcats, Scoops or Tournapulls, Bulldozers, Endloaders or Fork Lifts, Power Blade or Elevating Graders, Winch Cats, Boom or Winch Trucks or Boom Tractors, Pipe Wrapping or Painting Machines, Asphalt Plant Engineer, Journeyman Lubricating Engineer, Drills (other than Derrick Type), Mud Jacks, or Well Drilling Machines, Boring Machines or Track Jacks, Mixers, Conveyors (Two), Air Compressors (Two), Water Pumps regardless of size (Two), Welding Machines (Two), Siphons or Jets (Two), Winch Heads or Apparatuses (Two), Light Plants (Two), All Tractors regardless of size (straight tractor only), Fireman on Stationary Boilers, Automatic Elevators, Form Grading Machines, Finishing Machines, Power Sub-Grader or Ribbon Machines, Longitudinal Floats, Distributor Operators on Trucks, Winch Heads or Apparatuses (One), Mobil Track air and heaters (two to five), Heavy Equipment Greaser, Relief Operator, Assistant Master Mechanic and Heavy Duty Mechanic, self-propelled concrete saws

of all types and sizes with their attachments, gob-hoppers, excavators all sizes, the repair and greasing of all diesel hammers, the operation and set-up of bidwells, water blasters of all sizes and their clutches, hydraulic jacks where used for hoisting, operation of log skidders, iceolators used on and off of pipeline, condor cranes, bow boats, survey boats, bobcats and all their attachments, skid steer loaders and all their attachments, creter cranes, batch plants, operator (all sizes), self propelled roto mills, operation of conveyor systems of any size and any configuration, operation, repair and service of all vibratory hammers, all power pacs and their controls regardless of location, curtains or brush burning machines, stump cutter machines, Nail launchers when mounted on a machine or self-propelled, operation of con-cover machines, and all Operators except those listed below).

GROUP II. Assistant Operators.

GROUP III. Air Compressors (One), Water Pumps, regardless of Size (One), Waterblasters (one), Welding Machine (One), Mixers (One Bag), Conveyor (One), Siphon or Jet (One), Light Plant (One), Heater (One), Immobile Track Air (One), and Self Propelled Walk-Behind Rollers.

GROUP IV. Asphalt Spreader Oilers, Fireman on Whirlies and Heavy Equipment Oilers, Truck Cranes, Dredges, Monigans, Large Cranes - (Over 65-ton rated capacity) Concrete Plant Oiler, Blacktop Plant Oiler, and Creter Crane Oiler (when required).

GROUP V. Oiler.

GROUP VI. Operators on equipment with Booms, including jibs, 100 feet and over, and less than 150 feet long.

GROUP VII. Operators on equipment with Booms, including jibs, 150 feet and over, and less than 200 feet long.

GROUP VIII. Operators on Equipment with Booms, including jibs, 200 feet and over; Tower Cranes; and Whirlie Cranes.

GROUP IX. Master Mechanic

OPERATING ENGINEERS - Highway

GROUP I. Cranes, Dragline, Shovels, Skimmer Scoops, Clamshells or Derrick Boats, Pile Drivers, Crane-Type Backhoes, Asphalt Plant Operators, Concrete Plant Operators, Dredges, Asphalt Spreading Machines, All Locomotives, Cable Ways or Tower Machines, Hoists, Hydraulic Backhoes, Ditching Machines or Backfiller, Cherrypickers, Overhead Cranes, Roller - Steam or Gas, Concrete Pavers, Excavators, Concrete Breakers, Concrete Pumps, Bulk Cement Plants, Cement Pumps, Derrick-Type Drills, Boat Operators, Motor Graders or Pushcats, Scoops or Tournapulls, Bulldozers, Endloaders or Fork Lifts, Power Blade or Elevating Graders, Winch Cats, Boom or Winch Trucks or Boom Tractors, Pipe Wrapping or Painting Machines, Asphalt Plant Engineer, Journeyman Lubricating Engineer, Drills (other than Derrick Type), Mud Jacks, Well Drilling Machines, Boring Machines, Track Jacks, Mixers, Conveyors (Two), Air Compressors (Two), Water Pumps regardless of size (Two), Welding Machines (Two), Siphons or Jets (Two), Winch Heads or Apparatuses (Two), Light Plants (Two), All Tractors regardless of size (straight tractor only), Fireman on Stationary Boilers, Automatic Elevators, Form Grading Machines, Finishing Machines, Power Sub-Grader or Ribbon Machines, Longitudinal Floats, Distributor Operators on Trucks, Winch Heads or Apparatuses (One), Mobil Track air and heaters (two to five), Heavy Equipment Greaser, Relief Operator, Assistant

Master Mechanic and Heavy Duty Mechanic, self-propelled concrete saws of all types and sizes with their attachments, gob-hoppers, excavators all sizes, the repair and greasing of all diesel hammers, the operation and set-up of bidwells, water blasters of all sizes and their clutches, hydraulic jacks where used for hoisting, operation of log skidders, iceolators used on and off of pipeline, condor cranes, bow boats, survey boats, bobcats and all their attachments, skid steer loaders and all their attachments, creter cranes, batch plants, operator (all sizes), self propelled roto mills, operation of conveyer systems of any size and any configuration, operation, repair and service of all vibratory hammers, all power pacs and their controls regardless of location, curtains or brush burning machines, stump cutter machines, Nail launchers when mounted on a machine or self-propelled, operation of con-cover machines, and all Operators (except those listed below).

GROUP II. Assistant Operators.

GROUP III. Air Compressors (One), Water Pumps, regardless of Size (One), Waterblasters (one), Welding Machine (One), Mixers (One Bag), Conveyor (One), Siphon or Jet (One), Light Plant (One), Heater (One), Immobile Track Air (One), and Self Propelled Walk-Behind Rollers.

GROUP IV. Asphalt Spreader Oilers, Fireman on Whirlies and Heavy Equipment Oilers, Truck Cranes, Dredges, Monigans, Large Cranes - (Over 65-ton rated capacity) Concrete Plant Oiler, Blacktop Plant Oiler, and Creter Crane Oiler (when required).

GROUP V. Oiler.

GROUP VI. Operators on equipment with Booms, including jibs, 100 feet and over, and less than 150 feet long.

GROUP VII. Operators on equipment with Booms, including jibs, 150 feet and over, and less than 200 feet long.

GROUP VIII. Operators on Equipment with Booms, including jibs, 200 feet and over; Tower Cranes; and Whirlie Cranes.

GROUP IX. Mechanic

TRUCK DRIVER - BUILDING, HEAVY AND HIGHWAY CONSTRUCTION

Class 1. Drivers on 2 axle trucks hauling less than 9 ton. Air compressor and welding machines and brooms, including those pulled by separate units, truck driver helpers, warehouse employees, mechanic helpers, greasers and tiremen, pickup trucks when hauling materials, tools, or workers to and from and on-the-job site, and fork lifts up to 6,000 lb. capacity.

Class 2. Two or three axle trucks hauling more than 9 ton but hauling less than 16 ton. A-frame winch trucks, hydrolift trucks, vactor trucks or similar equipment when used for transportation purposes. Fork lifts over 6,000 lb. capacity, winch trucks, four axle combination units, and ticket writers.

Class 3. Two, three or four axle trucks hauling 16 ton or more. Drivers on water pulls, articulated dump trucks, mechanics and working forepersons, and dispatchers. Five axle or more combination units.

Class 4. Low Boy and Oil Distributors.

Class 5. Drivers who require special protective clothing while

employed on hazardous waste work.

TRUCK DRIVER - OIL AND CHIP RESEALING ONLY.

This shall encompass laborers, workers and mechanics who drive contractor or subcontractor owned, leased, or hired pickup, dump, service, or oil distributor trucks. The work includes transporting materials and equipment (including but not limited to, oils, aggregate supplies, parts, machinery and tools) to or from the job site; distributing oil or liquid asphalt and aggregate; stock piling material when in connectin with the actual oil and chip contract. The Truck Driver (Oil & Chip Resealing) wage classification does not include supplier delivered materials.

TERRAZZO FINISHER

The handling of all materials used for Mosaic and Terrazzo work including preparing, mixing by hand, by mixing machine or transporting of pre-mixed materials and distributing with shovel, rake, hoe, or pail, all kinds of concrete foundations necessary for Mosaic and Terrazzo work, all cement terrazzo, magnesite terrazzo, Do-O-Tex terrazzo, epoxy matrix ter-razzo, exposed aggregate, rustic or rough washed for exterior or interior of buildings placed either by machine or by hand, and any other kind of mixture of plastics composed of chips or granules when mixed with cement, rubber, neoprene, vinyl, magnesium chloride or any other resinous or chemical substances used for seamless flooring systems, and all other building materials, all similar materials and all precast terrazzo work on jobs, all scratch coat used for Mosaic and Terrazzo work and sub-bed, tar paper and wire mesh (2x2 etc.) or lath. The rubbing, grinding, cleaning and finishing of same either by hand or by machine or by terrazzo resurfacing equipment on new or existing floors. When necessary finishers shall be allowed to assist the mechanics to spread sand bed, lay tarpaper and wire mesh (2x2 etc.) or lath. The finishing of cement floors where additional aggregate of stone is added by spreading or sprinkling on top of the finished base, and troweled or rolled into the finish and then the surface is ground by grinding machines.

Other Classifications of Work:

For definitions of classifications not otherwise set out, the Department generally has on files such definitions which are available. If a task to be performed is not subject to one of the classifications of pay set out, the Department will upon being contacted state which neighboring county has such a classification and provide such rate, such rate being deemed to exist by reference in this document. If no neighboring county rate applies to the task, the Department shall undertake a special determination, such special determination being then deemed to have existed under this determination. If a project requires these, or any classification not listed, please contact IDOL at 217-782-1710 for wage rates or clarifications.

LANDSCAPING

Landscaping work falls under the existing classifications for laborer, operating engineer and truck driver. The work performed by landscape plantsman and landscape laborer is covered by the existing classification of laborer. The work performed by landscape operators (regardless of equipment used or its size) is covered by the

classifications of operating engineer. The work performed by landscape truck drivers (regardless of size of truck driven) is covered by the classifications of truck driver.

Clinton County Prevailing Wage for May 2012

(See explanation of column headings at bottom of wages)

| Trade Name | RG | TYP | C | Base | FRMAN | *M-F>8 | OSA | OSH | H/W | Pensn | Vac | Trng |
|----------------------|----|-------|---|--------|--------|--------|-----|-----|-------|-------|-------|-------|
| ===== | == | === | = | ===== | ===== | ===== | === | === | ===== | ===== | ===== | ===== |
| ASBESTOS ABT-GEN | | ALL | | 25.100 | 25.600 | 1.5 | 1.5 | 2.0 | 5.550 | 14.05 | 0.000 | 0.800 |
| ASBESTOS ABT-MEC | | BLD | | 29.160 | 30.160 | 1.5 | 1.5 | 2.0 | 6.700 | 2.750 | 0.000 | 0.000 |
| BOILERMAKER | | BLD | | 31.500 | 34.000 | 1.5 | 1.5 | 2.0 | 7.070 | 18.73 | 1.000 | 0.350 |
| BRICK MASON | | BLD | | 28.790 | 30.640 | 1.5 | 1.5 | 2.0 | 7.500 | 9.430 | 2.000 | 0.400 |
| CARPENTER | | ALL | | 33.880 | 35.380 | 1.5 | 1.5 | 2.0 | 6.300 | 6.250 | 0.000 | 0.400 |
| CEMENT MASON | | ALL | | 31.000 | 32.000 | 1.5 | 1.5 | 2.0 | 8.750 | 11.00 | 0.000 | 0.200 |
| CERAMIC TILE FNSHER | | BLD | | 25.520 | 0.000 | 1.5 | 1.5 | 2.0 | 5.900 | 5.110 | 0.000 | 0.470 |
| ELECTRIC PWR EQMT OP | | ALL | | 34.800 | 0.000 | 1.5 | 2.0 | 2.0 | 5.850 | 9.750 | 0.000 | 0.260 |
| ELECTRIC PWR GRNDMAN | | ALL | | 25.980 | 0.000 | 1.5 | 2.0 | 2.0 | 4.370 | 7.280 | 0.000 | 0.190 |
| ELECTRIC PWR LINEMAN | | ALL | | 40.020 | 41.950 | 1.5 | 2.0 | 2.0 | 6.720 | 11.21 | 0.000 | 0.300 |
| ELECTRIC PWR TRK DRV | | ALL | | 28.410 | 0.000 | 1.5 | 2.0 | 2.0 | 4.780 | 7.950 | 0.000 | 0.210 |
| ELECTRICIAN | E | ALL | | 37.930 | 40.180 | 1.5 | 1.5 | 2.0 | 5.350 | 9.110 | 0.000 | 0.760 |
| ELECTRICIAN | W | ALL | | 36.510 | 38.700 | 1.5 | 1.5 | 2.0 | 7.210 | 7.490 | 0.000 | 0.640 |
| ELECTRONIC SYS TECH | E | BLD | | 31.870 | 33.620 | 1.5 | 1.5 | 2.0 | 5.350 | 4.150 | 0.000 | 0.400 |
| ELECTRONIC SYS TECH | W | BLD | | 29.920 | 31.670 | 1.5 | 1.5 | 2.0 | 3.200 | 7.400 | 0.000 | 0.250 |
| ELEVATOR CONSTRUCTOR | | BLD | | 43.345 | 48.760 | 2.0 | 2.0 | 2.0 | 11.03 | 11.96 | 2.600 | 0.000 |
| FLOOR LAYER | | BLD | | 29.080 | 29.830 | 1.5 | 1.5 | 2.0 | 6.300 | 6.250 | 0.000 | 0.400 |
| GLAZIER | | BLD | | 32.780 | 0.000 | 2.0 | 2.0 | 2.0 | 9.020 | 10.80 | 2.630 | 0.310 |
| HT/FROST INSULATOR | | BLD | | 36.760 | 37.760 | 1.5 | 1.5 | 2.0 | 7.550 | 10.76 | 0.000 | 0.500 |
| IRON WORKER | | ALL | | 31.000 | 33.000 | 1.5 | 1.5 | 2.0 | 7.110 | 12.35 | 0.000 | 0.420 |
| LABORER | | ALL | | 24.600 | 25.100 | 1.5 | 1.5 | 2.0 | 5.550 | 14.05 | 0.000 | 0.800 |
| MACHINIST | | BLD | | 43.160 | 45.160 | 1.5 | 1.5 | 2.0 | 7.980 | 8.950 | 0.000 | 0.000 |
| MARBLE FINISHERS | | BLD | | 25.520 | 0.000 | 1.5 | 1.5 | 2.0 | 5.900 | 5.110 | 0.000 | 0.470 |
| MILLWRIGHT | | ALL | | 33.880 | 35.380 | 1.5 | 1.5 | 2.0 | 6.300 | 6.250 | 0.000 | 0.400 |
| OPERATING ENGINEER | | BLD 1 | | 33.650 | 36.650 | 1.5 | 1.5 | 2.0 | 8.400 | 16.50 | 0.000 | 1.000 |
| OPERATING ENGINEER | | BLD 2 | | 32.520 | 36.650 | 1.5 | 1.5 | 2.0 | 8.400 | 16.50 | 0.000 | 1.000 |
| OPERATING ENGINEER | | BLD 3 | | 28.040 | 36.650 | 1.5 | 1.5 | 2.0 | 8.400 | 16.50 | 0.000 | 1.000 |
| OPERATING ENGINEER | | BLD 4 | | 28.100 | 36.650 | 1.5 | 1.5 | 2.0 | 8.400 | 16.50 | 0.000 | 1.000 |
| OPERATING ENGINEER | | BLD 5 | | 27.770 | 36.650 | 1.5 | 1.5 | 2.0 | 8.400 | 16.50 | 0.000 | 1.000 |
| OPERATING ENGINEER | | BLD 6 | | 34.200 | 36.650 | 1.5 | 1.5 | 2.0 | 8.400 | 16.50 | 0.000 | 1.000 |
| OPERATING ENGINEER | | BLD 7 | | 34.500 | 36.650 | 1.5 | 1.5 | 2.0 | 8.400 | 16.50 | 0.000 | 1.000 |
| OPERATING ENGINEER | | BLD 8 | | 34.780 | 36.650 | 1.5 | 1.5 | 2.0 | 8.400 | 16.50 | 0.000 | 1.000 |
| OPERATING ENGINEER | | BLD 9 | | 35.650 | 36.650 | 1.5 | 1.5 | 2.0 | 8.400 | 16.50 | 0.000 | 1.000 |
| OPERATING ENGINEER | | HWY 1 | | 32.150 | 35.150 | 1.5 | 1.5 | 2.0 | 8.400 | 16.50 | 0.000 | 1.000 |
| OPERATING ENGINEER | | HWY 2 | | 31.020 | 35.150 | 1.5 | 1.5 | 2.0 | 8.400 | 16.50 | 0.000 | 1.000 |
| OPERATING ENGINEER | | HWY 3 | | 26.540 | 35.150 | 1.5 | 1.5 | 2.0 | 8.400 | 16.50 | 0.000 | 1.000 |
| OPERATING ENGINEER | | HWY 4 | | 26.600 | 35.150 | 1.5 | 1.5 | 2.0 | 8.400 | 16.50 | 0.000 | 1.000 |
| OPERATING ENGINEER | | HWY 5 | | 26.270 | 35.150 | 1.5 | 1.5 | 2.0 | 8.400 | 16.50 | 0.000 | 1.000 |
| OPERATING ENGINEER | | HWY 6 | | 32.700 | 35.150 | 1.5 | 1.5 | 2.0 | 8.400 | 16.50 | 0.000 | 1.000 |
| OPERATING ENGINEER | | HWY 7 | | 33.000 | 35.150 | 1.5 | 1.5 | 2.0 | 8.400 | 16.50 | 0.000 | 1.000 |
| OPERATING ENGINEER | | HWY 8 | | 33.280 | 35.150 | 1.5 | 1.5 | 2.0 | 8.400 | 16.50 | 0.000 | 1.000 |
| OPERATING ENGINEER | | HWY 9 | | 34.150 | 35.150 | 1.5 | 1.5 | 2.0 | 8.400 | 16.50 | 0.000 | 1.000 |
| PAINTER | | BLD | | 29.250 | 30.750 | 1.5 | 1.5 | 2.0 | 5.000 | 7.920 | 0.000 | 0.600 |
| PAINTER | | HWY | | 30.450 | 31.950 | 1.5 | 1.5 | 2.0 | 5.000 | 7.920 | 0.000 | 0.600 |
| PAINTER OVER 30FT | | BLD | | 30.250 | 31.750 | 1.5 | 1.5 | 2.0 | 5.000 | 7.920 | 0.000 | 0.600 |
| PAINTER PWR EQMT | | BLD | | 30.250 | 31.750 | 1.5 | 1.5 | 2.0 | 5.000 | 7.920 | 0.000 | 0.600 |
| PAINTER PWR EQMT | | HWY | | 31.450 | 32.950 | 1.5 | 1.5 | 2.0 | 5.000 | 7.920 | 0.000 | 0.600 |
| PILEDRIVER | | ALL | | 33.880 | 35.380 | 1.5 | 1.5 | 2.0 | 6.300 | 6.250 | 0.000 | 0.400 |
| PIPEFITTER | E | BLD | | 33.250 | 36.580 | 1.5 | 1.5 | 2.0 | 5.950 | 6.350 | 0.000 | 0.900 |
| PIPEFITTER | NW | BLD | | 36.000 | 38.000 | 1.5 | 1.5 | 2.0 | 6.690 | 8.000 | 0.000 | 0.750 |
| PIPEFITTER | SW | BLD | | 35.350 | 37.850 | 1.5 | 1.5 | 2.0 | 7.500 | 5.400 | 0.000 | 0.575 |
| PLASTERER | | BLD | | 30.250 | 31.250 | 1.5 | 1.5 | 2.0 | 8.750 | 8.300 | 0.000 | 0.050 |
| PLUMBER | E | BLD | | 33.250 | 36.580 | 1.5 | 1.5 | 2.0 | 5.950 | 6.350 | 0.000 | 0.900 |
| PLUMBER | NW | BLD | | 35.150 | 37.650 | 1.5 | 1.5 | 2.0 | 6.000 | 6.600 | 0.000 | 0.400 |
| PLUMBER | SW | BLD | | 35.350 | 37.850 | 1.5 | 1.5 | 2.0 | 7.500 | 5.400 | 0.000 | 0.575 |
| ROOFER | | BLD | | 28.650 | 30.650 | 1.5 | 1.5 | 2.0 | 8.150 | 6.650 | 0.000 | 0.200 |
| SHEETMETAL WORKER | | ALL | | 31.690 | 33.190 | 1.5 | 1.5 | 2.0 | 7.130 | 6.730 | 1.910 | 0.360 |

| | | | | | | | | | | | |
|-------------------|-----|---|--------|--------|-----|-----|-----|-------|-------|-------|-------|
| SPRINKLER FITTER | BLD | | 37.830 | 40.830 | 2.0 | 2.0 | 2.0 | 8.550 | 10.35 | 0.000 | 0.850 |
| TERRAZZO FINISHER | BLD | | 31.240 | 0.000 | 1.5 | 1.5 | 2.0 | 5.900 | 2.730 | 0.000 | 0.130 |
| TERRAZZO MASON | BLD | | 32.530 | 32.830 | 1.5 | 1.5 | 2.0 | 5.900 | 4.980 | 0.000 | 0.140 |
| TRUCK DRIVER | ALL | 1 | 30.460 | 0.000 | 1.5 | 1.5 | 2.0 | 10.05 | 4.775 | 0.000 | 0.250 |
| TRUCK DRIVER | ALL | 2 | 30.890 | 0.000 | 1.5 | 1.5 | 2.0 | 10.05 | 4.775 | 0.000 | 0.250 |
| TRUCK DRIVER | ALL | 3 | 31.120 | 0.000 | 1.5 | 1.5 | 2.0 | 10.05 | 4.775 | 0.000 | 0.250 |
| TRUCK DRIVER | ALL | 4 | 31.380 | 0.000 | 1.5 | 1.5 | 2.0 | 10.05 | 4.775 | 0.000 | 0.250 |
| TRUCK DRIVER | ALL | 5 | 32.200 | 0.000 | 1.5 | 1.5 | 2.0 | 10.05 | 4.775 | 0.000 | 0.250 |
| TRUCK DRIVER | O&C | 1 | 24.370 | 0.000 | 1.5 | 1.5 | 2.0 | 10.05 | 4.775 | 0.000 | 0.250 |
| TRUCK DRIVER | O&C | 2 | 24.710 | 0.000 | 1.5 | 1.5 | 2.0 | 10.05 | 4.775 | 0.000 | 0.250 |
| TRUCK DRIVER | O&C | 3 | 24.900 | 0.000 | 1.5 | 1.5 | 2.0 | 10.05 | 4.775 | 0.000 | 0.250 |
| TRUCK DRIVER | O&C | 4 | 25.100 | 0.000 | 1.5 | 1.5 | 2.0 | 10.05 | 4.775 | 0.000 | 0.250 |
| TRUCK DRIVER | O&C | 5 | 25.760 | 0.000 | 1.5 | 1.5 | 2.0 | 10.05 | 4.775 | 0.000 | 0.250 |

Legend :

RG (Region)

TYP (Trade Type - All,Highway,Building,Floating,Oil & Chip,Rivers)

C (Class)

Base (Base Wage Rate)

FRMAN (Foreman Rate)

M-F>8 (OT required for any hour greater than 8 worked each day, Mon through Fri.

OSA (Overtime (OT) is required for every hour worked on Saturday)

OSH (Overtime is required for every hour worked on Sunday and Holidays)

H/W (Health & Welfare Insurance)

Pensn (Pension)

Vac (Vacation)

Trng (Training)

Explanations

CLINTON COUNTY

ELECTRICIANS (WEST) - Townships of St. Rose, Wheatfield, Sugar Creek, Breese, Wade, Carlyle, Looking Glass, and German Town.

ELECTRONIC SYSTEMS TECHNICIAN (WEST) - Townships of St. Rose, Wheatfield, Sugar Creek, Breese, Wade, Carlyle, Looking Glass, and Germantown.

ELECTRONIC SYSTEMS TECHNICIAN (EAST) - Townships not included in WEST.

PLUMBERS & PIPEFITTERS (EAST) - That part of the county East of a North-South line 2.5 miles East of Rt. 127.

PLUMBERS & PIPEFITTERS (SOUTHWEST) - That part of the county South of New Route 50 and West of Route 127 inclusive.

The following list is considered as those days for which holiday rates of wages for work performed apply: New Years Day, Memorial Day, Fourth of July, Labor Day, Thanksgiving Day, Christmas Day and Veterans Day in some classifications/counties. Generally, any of these holidays which fall on a Sunday is celebrated on the following Monday. This then makes work performed on that Monday payable at the appropriate overtime rate for holiday pay. Common practice in a given local may alter certain days of celebration. If in doubt, please check with IDOL.

Oil and chip resealing (O&C) means the application of road oils and liquid asphalt to coat an existing road surface, followed by application of aggregate chips or gravel to coated surface, and subsequent rolling of material to seal the surface.

EXPLANATION OF CLASSES

ASBESTOS - GENERAL - removal of asbestos material/mold and hazardous materials from any place in a building, including mechanical systems where those mechanical systems are to be removed. This includes the removal of asbestos materials/mold and hazardous materials from ductwork or pipes in a building when the building is to be demolished at the time or at some close future date.

ASBESTOS - MECHANICAL - removal of asbestos material from mechanical systems, such as pipes, ducts, and boilers, where the mechanical systems are to remain.

CERAMIC TILE FINISHER AND MARBLE FINISHER

The handling, at the building site, of all sand, cement, tile, marble or stone and all other materials that may be used and installed by [a] tile layer or marble mason. In addition, the grouting, cleaning, sealing, and mixing on the job site, and all other work as required in assisting the setter. The term "Ceramic" is used for naming the classification only and is in no way a limitation of the product handled. Ceramic takes into consideration most hard tiles.

ELECTRONIC SYSTEMS TECHNICIAN

Installation, service and maintenance of low-voltage systems which utilizes the transmission and/or transference of voice, sound, vision, or digital for commercial, education, security and entertainment purposes for the following: TV monitoring and surveillance, background/foreground music, intercom and telephone interconnect, field programming, inventory control systems, microwave transmission, multi-media, multiplex, radio page, school, intercom and sound burglar alarms and low voltage master clock systems.

Excluded from this classification are energy management systems, life safety systems, supervisory controls and data acquisition systems not intrinsic with the above listed systems, fire alarm systems, nurse call systems and raceways exceeding fifteen feet in length.

OPERATING ENGINEER - BUILDING

GROUP I. Cranes, Dragline, Shovels, Skimmer Scoops, Clamshells or

Derrick Boats, Pile Drivers, Crane-Type Backhoes, Asphalt Plant Operators, Concrete Plant Operators, Dredges, Asphalt Spreading Machines, All Locomotives, Cable Ways or Tower Machines, Hoists, Hydraulic Backhoes, Ditching Machines or Backfiller, Cherrypickers, Overhead Cranes, Roller - Steam or Gas, Concrete Pavers, Excavators, Concrete Breakers, Concrete Pumps, Bulk Cement Plants, Cement Pumps, Derrick-Type Drills, Boat Operators, Motor Graders or Pushcats, Scoops or Tournapulls, Bulldozers, Endloaders or Fork Lifts, Power Blade or Elevating Graders, Winch Cats, Boom or Winch Trucks or Boom Tractors, Pipe Wrapping or Painting Machines, Asphalt Plant Engineer, Journeyman Lubricating Engineer, Drills (other than Derrick Type), Mud Jacks, or Well Drilling Machines, Boring Machines or Track Jacks, Mixers, Conveyors (Two), Air Compressors (Two), Water Pumps regardless of size (Two), Welding Machines (Two), Siphons or Jets (Two), Winch Heads or Apparatuses (Two), Light Plants (Two), All Tractors regardless of size (straight tractor only), Fireman on Stationary Boilers, Automatic Elevators, Form Grading Machines, Finishing Machines, Power Sub-Grader or Ribbon Machines, Longitudinal Floats, Distributor Operators on Trucks, Winch Heads or Apparatuses (One), Mobil Track air and heaters (two to five), Heavy Equipment Greaser, Relief Operator, Assistant Master Mechanic and Heavy Duty Mechanic, self-propelled concrete saws of all types and sizes with their attachments, gob-hoppers, excavators all sizes, the repair and greasing of all diesel hammers, the operation and set-up of bidwells, water blasters of all sizes and their clutches, hydraulic jacks where used for hoisting, operation of log skidders, iceolators used on and off of pipeline, condor cranes, bow boats, survey boats, bobcats and all their attachments, skid steer loaders and all their attachments, creter cranes, batch plants, operator (all sizes), self propelled roto mills, operation of conveyor systems of any size and any configuration, operation, repair and service of all vibratory hammers, all power pacs and their controls regardless of location, curtains or brush burning machines, stump cutter machines, Nail launchers when mounted on a machine or self-propelled, operation of con-cover machines, and all Operators except those listed below).

GROUP II. Assistant Operators.

GROUP III. Air Compressors (One), Water Pumps, regardless of Size (One), Waterblasters (one), Welding Machine (One), Mixers (One Bag), Conveyor (One), Siphon or Jet (One), Light Plant (One), Heater (One), Immobile Track Air (One), and Self Propelled Walk-Behind Rollers.

GROUP IV. Asphalt Spreader Oilers, Fireman on Whirlies and Heavy Equipment Oilers, Truck Cranes, Dredges, Monigans, Large Cranes - (Over 65-ton rated capacity) Concrete Plant Oiler, Blacktop Plant Oiler, and Creter Crane Oiler (when required).

GROUP V. Oiler.

GROUP VI. Operators on equipment with Booms, including jibs, 100 feet and over, and less than 150 feet long.

GROUP VII. Operators on equipment with Booms, including jibs, 150 feet and over, and less than 200 feet long.

GROUP VIII. Operators on Equipment with Booms, including jibs, 200 feet and over; Tower Cranes; and Whirlie Cranes.

GROUP IX. Master Mechanic

OPERATING ENGINEERS - Highway

GROUP I. Cranes, Dragline, Shovels, Skimmer Scoops, Clamshells or Derrick Boats, Pile Drivers, Crane-Type Backhoes, Asphalt Plant Operators, Concrete Plant Operators, Dredges, Asphalt Spreading Machines, All Locomotives, Cable Ways or Tower Machines, Hoists, Hydraulic Backhoes, Ditching Machines or Backfiller, Cherrypickers, Overhead Cranes, Roller - Steam or Gas, Concrete Pavers, Excavators, Concrete Breakers, Concrete Pumps, Bulk Cement Plants, Cement Pumps, Derrick-Type Drills, Boat Operators, Motor Graders or Pushcats, Scoops or Tournapulls, Bulldozers, Endloaders or Fork Lifts, Power Blade or Elevating Graders, Winch Cats, Boom or Winch Trucks or Boom Tractors, Pipe Wrapping or Painting Machines, Asphalt Plant Engineer, Journeyman Lubricating Engineer, Drills (other than Derrick Type), Mud Jacks, Well Drilling Machines, Boring Machines, Track Jacks, Mixers, Conveyors (Two), Air Compressors (Two), Water Pumps regardless of size (Two), Welding Machines (Two), Siphons or Jets (Two), Winch Heads or Apparatuses (Two), Light Plants (Two), All Tractors regardless of size (straight tractor only), Fireman on Stationary Boilers, Automatic Elevators, Form Grading Machines, Finishing Machines, Power Sub-Grader or Ribbon Machines, Longitudinal Floats, Distributor Operators on Trucks, Winch Heads or Apparatuses (One), Mobil Track air and heaters (two to five), Heavy Equipment Greaser, Relief Operator, Assistant Master Mechanic and Heavy Duty Mechanic, self-propelled concrete saws of all types and sizes with their attachments, gob-hoppers, excavators all sizes, the repair and greasing of all diesel hammers, the operation and set-up of bidwells, water blasters of all sizes and their clutches, hydraulic jacks where used for hoisting, operation of log skidders, iceolators used on and off of pipeline, condor cranes, bow boats, survey boats, bobcats and all their attachments, skid steer loaders and all their attachments, creter cranes, batch plants, operator (all sizes), self propelled roto mills, operation of conveyor systems of any size and any configuration, operation, repair and service of all vibratory hammers, all power pacs and their controls regardless of location, curtains or brush burning machines, stump cutter machines, Nail launchers when mounted on a machine or self-propelled, operation of con-cover machines, and all Operators (except those listed below).

GROUP II. Assistant Operators.

GROUP III. Air Compressors (One), Water Pumps, regardless of Size (One), Waterblasters (one), Welding Machine (One), Mixers (One Bag), Conveyor (One), Siphon or Jet (One), Light Plant (One), Heater (One), Immobile Track Air (One), and Self Propelled Walk-Behind Rollers.

GROUP IV. Asphalt Spreader Oilers, Fireman on Whirlies and Heavy Equipment Oilers, Truck Cranes, Dredges, Monigans, Large Cranes - (Over 65-ton rated capacity) Concrete Plant Oiler, Blacktop Plant Oiler, and Creter Crane Oiler (when required).

GROUP V. Oiler.

GROUP VI. Operators on equipment with Booms, including jibs, 100 feet and over, and less than 150 feet long.

GROUP VII. Operators on equipment with Booms, including jibs, 150 feet and over, and less than 200 feet long.

GROUP VIII. Operators on Equipment with Booms, including jibs, 200 feet and over; Tower Cranes; and Whirlie Cranes.

GROUP IX. Mechanic

TRUCK DRIVER - BUILDING, HEAVY AND HIGHWAY CONSTRUCTION

Class 1. Drivers on 2 axle trucks hauling less than 9 ton. Air compressor and welding machines and brooms, including those pulled by separate units, truck driver helpers, warehouse employees, mechanic helpers, greasers and tiremen, pickup trucks when hauling materials, tools, or workers to and from and on-the-job site, and fork lifts up to 6,000 lb. capacity.

Class 2. Two or three axle trucks hauling more than 9 ton but hauling less than 16 ton. A-frame winch trucks, hydrolift trucks, vector trucks or similar equipment when used for transportation purposes. Fork lifts over 6,000 lb. capacity, winch trucks, four axle combination units, and ticket writers.

Class 3. Two, three or four axle trucks hauling 16 ton or more. Drivers on water pulls, articulated dump trucks, mechanics and working forepersons, and dispatchers. Five axle or more combination units.

Class 4. Low Boy and Oil Distributors.

Class 5. Drivers who require special protective clothing while employed on hazardous waste work.

TRUCK DRIVER - OIL AND CHIP RESEALING ONLY.

This shall encompass laborers, workers and mechanics who drive contractor or subcontractor owned, leased, or hired pickup, dump, service, or oil distributor trucks. The work includes transporting materials and equipment (including but not limited to, oils, aggregate supplies, parts, machinery and tools) to or from the job site; distributing oil or liquid asphalt and aggregate; stock piling material when in connection with the actual oil and chip contract. The Truck Driver (Oil & Chip Resealing) wage classification does not include supplier delivered materials.

TERRAZZO FINISHER

The handling of all materials used for Mosaic and Terrazzo work including preparing, mixing by hand, by mixing machine or transporting of pre-mixed materials and distributing with shovel, rake, hoe, or pail, all kinds of concrete foundations necessary for Mosaic and Terrazzo work, all cement terrazzo, magnesite terrazzo, Do-O-Tex terrazzo, epoxy matrix ter-razzo, exposed aggregate, rustic or rough washed for exterior or interior of buildings placed either by machine or by hand, and any other kind of mixture of plastics composed of chips or granules when mixed with cement, rubber, neoprene, vinyl, magnesium chloride or any other resinous or chemical substances used for seamless flooring systems, and all other building materials, all similar materials and all precast terrazzo work on jobs, all scratch coat used for Mosaic and Terrazzo work and sub-bed, tar paper and wire mesh (2x2 etc.) or lath. The rubbing, grinding, cleaning and finishing of same either by hand or by machine or by terrazzo resurfacing equipment on new or existing floors. When necessary finishers shall be allowed to assist the mechanics to spread sand bed, lay tarpaper and wire mesh (2x2 etc.) or lath. The finishing of cement floors where additional aggregate of stone is added by spreading or sprinkling on top of the finished base, and troweled or rolled into the finish and then the surface is ground by grinding machines.

Other Classifications of Work:

For definitions of classifications not otherwise set out, the Department generally has on file such definitions which are available. If a task to be performed is not subject to one of the classifications of pay set out, the Department will upon being contacted state which neighboring county has such a classification and provide such rate, such rate being deemed to exist by reference in this document. If no neighboring county rate applies to the task, the Department shall undertake a special determination, such special determination being then deemed to have existed under this determination. If a project requires these, or any classification not listed, please contact IDOL at 217-782-1710 for wage rates or clarifications.

LANDSCAPING

Landscaping work falls under the existing classifications for laborer, operating engineer and truck driver. The work performed by landscape plantsman and landscape laborer is covered by the existing classification of laborer. The work performed by landscape operators (regardless of equipment used or its size) is covered by the classifications of operating engineer. The work performed by landscape truck drivers (regardless of size of truck driven) is covered by the classifications of truck driver.

Greene County Prevailing Wage for May 2012

(See explanation of column headings at bottom of wages)

| Trade Name | RG | TYP | C | Base | FRMAN | *M-F>8 | OSA | OSH | H/W | Pensn | Vac | Trng |
|----------------------|----|-----|---|--------|--------|--------|-----|-----|-------|-------|-------|-------|
| ===== | == | === | = | ===== | ===== | ===== | === | === | ===== | ===== | ===== | ===== |
| ASBESTOS ABT-GEN | | ALL | | 29.510 | 30.010 | 1.5 | 1.5 | 2.0 | 5.750 | 9.440 | 0.000 | 0.800 |
| ASBESTOS ABT-MEC | | BLD | | 29.160 | 30.160 | 1.5 | 1.5 | 2.0 | 6.700 | 2.750 | 0.000 | 0.000 |
| BOILERMAKER | | BLD | | 31.500 | 34.000 | 1.5 | 1.5 | 2.0 | 7.070 | 18.73 | 1.000 | 0.350 |
| BRICK MASON | | BLD | | 29.250 | 30.250 | 1.5 | 1.5 | 2.0 | 8.200 | 8.330 | 0.000 | 0.580 |
| CARPENTER | | BLD | | 27.670 | 29.920 | 1.5 | 1.5 | 2.0 | 7.350 | 13.43 | 0.000 | 0.420 |
| CARPENTER | | HWY | | 28.020 | 29.770 | 1.5 | 1.5 | 2.0 | 7.350 | 12.73 | 0.000 | 0.420 |
| CEMENT MASON | | ALL | | 31.000 | 32.000 | 1.5 | 1.5 | 2.0 | 8.750 | 11.00 | 0.000 | 0.200 |
| CERAMIC TILE FNSHER | | BLD | | 25.600 | 0.000 | 1.5 | 1.5 | 2.0 | 8.200 | 7.230 | 0.000 | 0.000 |
| ELECTRIC PWR EQMT OP | | ALL | | 36.690 | 44.520 | 1.5 | 2.0 | 2.0 | 5.000 | 9.170 | 0.000 | 0.280 |
| ELECTRIC PWR GRNDMAN | | ALL | | 24.940 | 44.520 | 1.5 | 2.0 | 2.0 | 5.000 | 6.240 | 0.000 | 0.190 |
| ELECTRIC PWR LINEMAN | | ALL | | 42.210 | 44.520 | 1.5 | 2.0 | 2.0 | 5.000 | 10.56 | 0.000 | 0.320 |
| ELECTRIC PWR TRK DRV | | ALL | | 25.560 | 44.520 | 1.5 | 2.0 | 2.0 | 5.000 | 6.390 | 0.000 | 0.190 |
| ELECTRICIAN | | ALL | | 36.400 | 38.650 | 1.5 | 1.5 | 2.0 | 7.500 | 9.090 | 0.000 | 0.550 |
| ELECTRONIC SYS TECH | | BLD | | 28.740 | 30.490 | 1.5 | 1.5 | 2.0 | 7.500 | 5.860 | 0.000 | 0.400 |
| ELEVATOR CONSTRUCTOR | | BLD | | 43.345 | 48.760 | 2.0 | 2.0 | 2.0 | 11.03 | 11.96 | 2.600 | 0.000 |
| GLAZIER | | BLD | | 32.780 | 0.000 | 2.0 | 2.0 | 2.0 | 9.020 | 10.80 | 2.630 | 0.310 |
| HT/FROST INSULATOR | | BLD | | 36.760 | 37.760 | 1.5 | 1.5 | 2.0 | 7.550 | 10.76 | 0.000 | 0.500 |
| IRON WORKER | | BLD | | 29.140 | 31.140 | 1.5 | 1.5 | 2.0 | 7.160 | 10.88 | 0.000 | 0.600 |
| IRON WORKER | | HWY | | 30.090 | 31.590 | 1.5 | 1.5 | 2.0 | 7.160 | 10.88 | 0.000 | 0.600 |
| LABORER | | ALL | | 29.010 | 29.510 | 1.5 | 1.5 | 2.0 | 5.750 | 9.440 | 0.000 | 0.800 |
| LATHER | | BLD | | 27.670 | 29.920 | 1.5 | 1.5 | 2.0 | 7.350 | 13.43 | 0.000 | 0.420 |
| MACHINIST | | BLD | | 43.160 | 45.160 | 1.5 | 1.5 | 2.0 | 7.980 | 8.950 | 0.000 | 0.000 |
| MARBLE FINISHERS | | BLD | | 25.600 | 0.000 | 1.5 | 1.5 | 2.0 | 8.200 | 7.230 | 0.000 | 0.000 |
| MARBLE MASON | | BLD | | 27.100 | 27.850 | 1.5 | 1.5 | 2.0 | 8.200 | 7.230 | 0.000 | 0.000 |
| MILLWRIGHT | | BLD | | 29.620 | 31.870 | 1.5 | 1.5 | 2.0 | 7.350 | 11.94 | 0.000 | 0.420 |
| MILLWRIGHT | | HWY | | 30.990 | 32.740 | 1.5 | 1.5 | 2.0 | 7.350 | 12.39 | 0.000 | 0.420 |
| OPERATING ENGINEER | | BLD | 1 | 33.650 | 36.650 | 1.5 | 1.5 | 2.0 | 8.400 | 16.50 | 0.000 | 1.000 |
| OPERATING ENGINEER | | BLD | 2 | 32.520 | 36.650 | 1.5 | 1.5 | 2.0 | 8.400 | 16.50 | 0.000 | 1.000 |
| OPERATING ENGINEER | | BLD | 3 | 28.040 | 36.650 | 1.5 | 1.5 | 2.0 | 8.400 | 16.50 | 0.000 | 1.000 |
| OPERATING ENGINEER | | BLD | 4 | 28.100 | 36.650 | 1.5 | 1.5 | 2.0 | 8.400 | 16.50 | 0.000 | 1.000 |
| OPERATING ENGINEER | | BLD | 5 | 27.770 | 36.650 | 1.5 | 1.5 | 2.0 | 8.400 | 16.50 | 0.000 | 1.000 |
| OPERATING ENGINEER | | BLD | 6 | 34.200 | 36.650 | 1.5 | 1.5 | 2.0 | 8.400 | 16.50 | 0.000 | 1.000 |
| OPERATING ENGINEER | | BLD | 7 | 34.500 | 36.650 | 1.5 | 1.5 | 2.0 | 8.400 | 16.50 | 0.000 | 1.000 |
| OPERATING ENGINEER | | BLD | 8 | 34.780 | 36.650 | 1.5 | 1.5 | 2.0 | 8.400 | 16.50 | 0.000 | 1.000 |
| OPERATING ENGINEER | | BLD | 9 | 35.650 | 36.650 | 1.5 | 1.5 | 2.0 | 8.400 | 16.50 | 0.000 | 1.000 |
| OPERATING ENGINEER | | HWY | 1 | 32.150 | 35.150 | 1.5 | 1.5 | 2.0 | 8.400 | 16.50 | 0.000 | 1.000 |
| OPERATING ENGINEER | | HWY | 2 | 31.020 | 35.150 | 1.5 | 1.5 | 2.0 | 8.400 | 16.50 | 0.000 | 1.000 |
| OPERATING ENGINEER | | HWY | 3 | 26.540 | 35.150 | 1.5 | 1.5 | 2.0 | 8.400 | 16.50 | 0.000 | 1.000 |
| OPERATING ENGINEER | | HWY | 4 | 26.600 | 35.150 | 1.5 | 1.5 | 2.0 | 8.400 | 16.50 | 0.000 | 1.000 |
| OPERATING ENGINEER | | HWY | 5 | 26.270 | 35.150 | 1.5 | 1.5 | 2.0 | 8.400 | 16.50 | 0.000 | 1.000 |
| OPERATING ENGINEER | | HWY | 6 | 32.700 | 35.150 | 1.5 | 1.5 | 2.0 | 8.400 | 16.50 | 0.000 | 1.000 |
| OPERATING ENGINEER | | HWY | 7 | 33.000 | 35.150 | 1.5 | 1.5 | 2.0 | 8.400 | 16.50 | 0.000 | 1.000 |
| OPERATING ENGINEER | | HWY | 8 | 33.280 | 35.150 | 1.5 | 1.5 | 2.0 | 8.400 | 16.50 | 0.000 | 1.000 |
| OPERATING ENGINEER | | HWY | 9 | 34.150 | 35.150 | 1.5 | 1.5 | 2.0 | 8.400 | 16.50 | 0.000 | 1.000 |
| PAINTER | | BLD | | 29.250 | 30.750 | 1.5 | 1.5 | 2.0 | 5.000 | 7.920 | 0.000 | 0.600 |
| PAINTER | | HWY | | 30.450 | 31.950 | 1.5 | 1.5 | 2.0 | 5.000 | 7.920 | 0.000 | 0.600 |
| PAINTER OVER 30FT | | BLD | | 30.250 | 31.750 | 1.5 | 1.5 | 2.0 | 5.000 | 7.920 | 0.000 | 0.600 |
| PAINTER PWR EQMT | | BLD | | 30.250 | 31.750 | 1.5 | 1.5 | 2.0 | 5.000 | 7.920 | 0.000 | 0.600 |
| PAINTER PWR EQMT | | HWY | | 31.450 | 32.950 | 1.5 | 1.5 | 2.0 | 5.000 | 7.920 | 0.000 | 0.600 |
| PILEDRIVER | | BLD | | 28.170 | 30.420 | 1.5 | 1.5 | 2.0 | 7.350 | 13.43 | 0.000 | 0.420 |
| PILEDRIVER | | HWY | | 29.020 | 30.770 | 1.5 | 1.5 | 2.0 | 7.350 | 12.73 | 0.000 | 0.420 |
| PIPEFITTER | | BLD | | 35.800 | 37.590 | 2.0 | 2.0 | 2.0 | 4.400 | 8.360 | 0.000 | 0.200 |
| PLASTERER | | BLD | | 30.250 | 31.250 | 1.5 | 1.5 | 2.0 | 8.750 | 8.300 | 0.000 | 0.050 |
| PLUMBER | | BLD | | 35.800 | 37.590 | 2.0 | 2.0 | 2.0 | 4.400 | 8.360 | 0.000 | 0.200 |
| ROOFER | | BLD | | 28.650 | 30.650 | 1.5 | 1.5 | 2.0 | 8.150 | 6.650 | 0.000 | 0.200 |
| SHEETMETAL WORKER | | ALL | | 31.690 | 33.190 | 1.5 | 1.5 | 2.0 | 7.130 | 6.730 | 1.910 | 0.360 |
| SPRINKLER FITTER | | BLD | | 37.830 | 40.830 | 2.0 | 2.0 | 2.0 | 8.550 | 10.35 | 0.000 | 0.850 |

| | | | | | | | | | | |
|-------------------|-------|--------|--------|-----|-----|-----|-------|-------|-------|-------|
| STONE MASON | BLD | 29.250 | 30.250 | 1.5 | 1.5 | 2.0 | 8.200 | 8.330 | 0.000 | 0.580 |
| TERRAZZO FINISHER | BLD | 25.600 | 0.000 | 1.5 | 1.5 | 2.0 | 8.200 | 7.230 | 0.000 | 0.000 |
| TERRAZZO MASON | BLD | 27.100 | 27.850 | 1.5 | 1.5 | 2.0 | 8.200 | 7.230 | 0.000 | 0.000 |
| TILE MASON | BLD | 27.100 | 27.850 | 1.5 | 1.5 | 2.0 | 8.200 | 7.230 | 0.000 | 0.000 |
| TRUCK DRIVER | ALL 1 | 30.460 | 0.000 | 1.5 | 1.5 | 2.0 | 10.05 | 4.775 | 0.000 | 0.250 |
| TRUCK DRIVER | ALL 2 | 30.890 | 0.000 | 1.5 | 1.5 | 2.0 | 10.05 | 4.775 | 0.000 | 0.250 |
| TRUCK DRIVER | ALL 3 | 31.120 | 0.000 | 1.5 | 1.5 | 2.0 | 10.05 | 4.775 | 0.000 | 0.250 |
| TRUCK DRIVER | ALL 4 | 31.380 | 0.000 | 1.5 | 1.5 | 2.0 | 10.05 | 4.775 | 0.000 | 0.250 |
| TRUCK DRIVER | ALL 5 | 32.200 | 0.000 | 1.5 | 1.5 | 2.0 | 10.05 | 4.775 | 0.000 | 0.250 |
| TRUCK DRIVER | O&C 1 | 24.370 | 0.000 | 1.5 | 1.5 | 2.0 | 10.05 | 4.775 | 0.000 | 0.250 |
| TRUCK DRIVER | O&C 2 | 24.710 | 0.000 | 1.5 | 1.5 | 2.0 | 10.05 | 4.775 | 0.000 | 0.250 |
| TRUCK DRIVER | O&C 3 | 24.900 | 0.000 | 1.5 | 1.5 | 2.0 | 10.05 | 4.775 | 0.000 | 0.250 |
| TRUCK DRIVER | O&C 4 | 25.100 | 0.000 | 1.5 | 1.5 | 2.0 | 10.05 | 4.775 | 0.000 | 0.250 |
| TRUCK DRIVER | O&C 5 | 25.760 | 0.000 | 1.5 | 1.5 | 2.0 | 10.05 | 4.775 | 0.000 | 0.250 |
| TUCKPOINTER | BLD | 29.250 | 30.250 | 1.5 | 1.5 | 2.0 | 8.200 | 8.330 | 0.000 | 0.580 |

Legend :

RG (Region)

TYP (Trade Type - All,Highway,Building,Floating,Oil & Chip,Rivers)

C (Class)

Base (Base Wage Rate)

FRMAN (Foreman Rate)

M-F>8 (OT required for any hour greater than 8 worked each day, Mon through Fri.

OSA (Overtime (OT) is required for every hour worked on Saturday)

OSH (Overtime is required for every hour worked on Sunday and Holidays)

H/W (Health & Welfare Insurance)

Pensn (Pension)

Vac (Vacation)

Trng (Training)

Explanations

GREENE COUNTY

The following list is considered as those days for which holiday rates of wages for work performed apply: New Years Day, Memorial Day, Fourth of July, Labor Day, Thanksgiving Day, Christmas Day and Veterans Day in some classifications/counties. Generally, any of these holidays which fall on a Sunday is celebrated on the following

Monday. This then makes work performed on that Monday payable at the appropriate overtime rate for holiday pay. Common practice in a given local may alter certain days of celebration. If in doubt, please check with IDOL.

Oil and chip resealing (O&C) means the application of road oils and liquid asphalt to coat an existing road surface, followed by application of aggregate chips or gravel to coated surface, and subsequent rolling of material to seal the surface.

EXPLANATION OF CLASSES

ASBESTOS - GENERAL - removal of asbestos material/mold and hazardous materials from any place in a building, including mechanical systems where those mechanical systems are to be removed. This includes the removal of asbestos materials/mold and hazardous materials from ductwork or pipes in a building when the building is to be demolished at the time or at some close future date.

ASBESTOS - MECHANICAL - removal of asbestos material from mechanical systems, such as pipes, ducts, and boilers, where the mechanical systems are to remain.

CERAMIC TILE FINISHER, MARBLE FINISHER, TERRAZZO FINISHER

Assisting, helping or supporting the tile, marble and terrazzo mechanic by performing their historic and traditional work assignments required to complete the proper installation of the work covered by said crafts. The term "Ceramic" is used for naming the classification only and is in no way a limitation of the product handled. Ceramic takes into consideration most hard tiles.

ELECTRONIC SYSTEMS TECHNICIAN

Installation, service and maintenance of low-voltage systems which utilizes the transmission and/or transference of voice, sound, vision, or digital for commercial, education, security and entertainment purposes for the following: TV monitoring and surveillance, background/foreground music, intercom and telephone interconnect, field programming, inventory control systems, microwave transmission, multi-media, multiplex, radio page, school, intercom and sound burglar alarms and low voltage master clock systems.

Excluded from this classification are energy management systems, life safety systems, supervisory controls and data acquisition systems not intrinsic with the above listed systems, fire alarm systems, nurse call systems and raceways exceeding fifteen feet in length.

OPERATING ENGINEER - BUILDING

GROUP I. Cranes, Dragline, Shovels, Skimmer Scoops, Clamshells or Derrick Boats, Pile Drivers, Crane-Type Backhoes, Asphalt Plant Operators, Concrete Plant Operators, Dredges, Asphalt Spreading Machines, All Locomotives, Cable Ways or Tower Machines, Hoists, Hydraulic Backhoes, Ditching Machines or Backfiller, Cherrypickers, Overhead Cranes, Roller - Steam or Gas, Concrete Pavers, Excavators, Concrete Breakers, Concrete Pumps, Bulk Cement Plants, Cement Pumps, Derrick-Type Drills, Boat Operators, Motor Graders or Pushcats, Scoops or Tournapulls, Bulldozers, Endloaders or Fork Lifts, Power Blade or Elevating Graders, Winch Cats, Boom or Winch Trucks or Boom Tractors, Pipe Wrapping or Painting Machines, Asphalt Plant Engineer, Journeyman Lubricating Engineer, Drills (other than Derrick Type), Mud Jacks, or Well Drilling Machines, Boring Machines or Track Jacks, Mixers,

Conveyors (Two), Air Compressors (Two), Water Pumps regardless of size (Two), Welding Machines (Two), Siphons or Jets (Two), Winch Heads or Apparatuses (Two), Light Plants (Two), All Tractors regardless of size (straight tractor only), Fireman on Stationary Boilers, Automatic Elevators, Form Grading Machines, Finishing Machines, Power Sub-Grader or Ribbon Machines, Longitudinal Floats, Distributor Operators on Trucks, Winch Heads or Apparatuses (One), Mobil Track air and heaters (two to five), Heavy Equipment Greaser, Relief Operator, Assistant Master Mechanic and Heavy Duty Mechanic, self-propelled concrete saws of all types and sizes with their attachments, gob-hoppers, excavators all sizes, the repair and greasing of all diesel hammers, the operation and set-up of bidwells, water blasters of all sizes and their clutches, hydraulic jacks where used for hoisting, operation of log skidders, iceolators used on and off of pipeline, condor cranes, bow boats, survey boats, bobcats and all their attachments, skid steer loaders and all their attachments, creter cranes, batch plants, operator (all sizes), self propelled roto mills, operation of conveyor systems of any size and any configuration, operation, repair and service of all vibratory hammers, all power pacs and their controls regardless of location, curtains or brush burning machines, stump cutter machines, Nail launchers when mounted on a machine or self-propelled, operation of con-cover machines, and all Operators except those listed below).

GROUP II. Assistant Operators.

GROUP III. Air Compressors (One), Water Pumps, regardless of Size (One), Waterblasters (one), Welding Machine (One), Mixers (One Bag), Conveyor (One), Siphon or Jet (One), Light Plant (One), Heater (One), Immobile Track Air (One), and Self Propelled Walk-Behind Rollers.

GROUP IV. Asphalt Spreader Oilers, Fireman on Whirlies and Heavy Equipment Oilers, Truck Cranes, Dredges, Monigans, Large Cranes - (Over 65-ton rated capacity) Concrete Plant Oiler, Blacktop Plant Oiler, and Creter Crane Oiler (when required).

GROUP V. Oiler.

GROUP VI. Operators on equipment with Booms, including jibs, 100 feet and over, and less than 150 feet long.

GROUP VII. Operators on equipment with Booms, including jibs, 150 feet and over, and less than 200 feet long.

GROUP VIII. Operators on Equipment with Booms, including jibs, 200 feet and over; Tower Cranes; and Whirlie Cranes.

GROUP IX. Master Mechanic

OPERATING ENGINEERS - Highway

GROUP I. Cranes, Dragline, Shovels, Skimmer Scoops, Clamshells or Derrick Boats, Pile Drivers, Crane-Type Backhoes, Asphalt Plant Operators, Concrete Plant Operators, Dredges, Asphalt Spreading Machines, All Locomotives, Cable Ways or Tower Machines, Hoists, Hydraulic Backhoes, Ditching Machines or Backfiller, Cherrypickers, Overhead Cranes, Roller - Steam or Gas, Concrete Pavers, Excavators, Concrete Breakers, Concrete Pumps, Bulk Cement Plants, Cement Pumps, Derrick-Type Drills, Boat Operators, Motor Graders or Pushcats, Scoops or Tournapulls, Bulldozers, Endloaders or Fork Lifts, Power Blade or Elevating Graders, Winch Cats, Boom or Winch Trucks or Boom Tractors, Pipe Wrapping or Painting Machines, Asphalt Plant Engineer, Journeyman Lubricating Engineer, Drills (other than Derrick Type), Mud Jacks,

Well Drilling Machines, Boring Machines, Track Jacks, Mixers, Conveyors (Two), Air Compressors (Two), Water Pumps regardless of size (Two), Welding Machines (Two), Siphons or Jets (Two), Winch Heads or Apparatuses (Two), Light Plants (Two), All Tractors regardless of size (straight tractor only), Fireman on Stationary Boilers, Automatic Elevators, Form Grading Machines, Finishing Machines, Power Sub-Grader or Ribbon Machines, Longitudinal Floats, Distributor Operators on Trucks, Winch Heads or Apparatuses (One), Mobil Track air and heaters (two to five), Heavy Equipment Greaser, Relief Operator, Assistant Master Mechanic and Heavy Duty Mechanic, self-propelled concrete saws of all types and sizes with their attachments, gob-hoppers, excavators all sizes, the repair and greasing of all diesel hammers, the operation and set-up of bidwells, water blasters of all sizes and their clutches, hydraulic jacks where used for hoisting, operation of log skidders, iceolators used on and off of pipeline, condor cranes, bow boats, survey boats, bobcats and all their attachments, skid steer loaders and all their attachments, creter cranes, batch plants, operator (all sizes), self propelled roto mills, operation of conveyor systems of any size and any configuration, operation, repair and service of all vibratory hammers, all power pacs and their controls regardless of location, curtains or brush burning machines, stump cutter machines, Nail launchers when mounted on a machine or self-propelled, operation of con-cover machines, and all Operators (except those listed below).

GROUP II. Assistant Operators.

GROUP III. Air Compressors (One), Water Pumps, regardless of Size (One), Waterblasters (one), Welding Machine (One), Mixers (One Bag), Conveyor (One), Siphon or Jet (One), Light Plant (One), Heater (One), Immobile Track Air (One), and Self Propelled Walk-Behind Rollers.

GROUP IV. Asphalt Spreader Oilers, Fireman on Whirlies and Heavy Equipment Oilers, Truck Cranes, Dredges, Monigans, Large Cranes - (Over 65-ton rated capacity) Concrete Plant Oiler, Blacktop Plant Oiler, and Creter Crane Oiler (when required).

GROUP V. Oiler.

GROUP VI. Operators on equipment with Booms, including jibs, 100 feet and over, and less than 150 feet long.

GROUP VII. Operators on equipment with Booms, including jibs, 150 feet and over, and less than 200 feet long.

GROUP VIII. Operators on Equipment with Booms, including jibs, 200 feet and over; Tower Cranes; and Whirlie Cranes.

GROUP IX. Mechanic

TRUCK DRIVER - BUILDING, HEAVY AND HIGHWAY CONSTRUCTION

Class 1. Drivers on 2 axle trucks hauling less than 9 ton. Air compressor and welding machines and brooms, including those pulled by separate units, truck driver helpers, warehouse employees, mechanic helpers, greasers and tiremen, pickup trucks when hauling materials, tools, or workers to and from and on-the-job site, and fork lifts up to 6,000 lb. capacity.

Class 2. Two or three axle trucks hauling more than 9 ton but hauling less than 16 ton. A-frame winch trucks, hydrolift trucks, vactor trucks or similar equipment when used for transportation purposes.

Fork lifts over 6,000 lb. capacity, winch trucks, four axle combination units, and ticket writers.

Class 3. Two, three or four axle trucks hauling 16 ton or more. Drivers on water pulls, articulated dump trucks, mechanics and working forepersons, and dispatchers. Five axle or more combination units.

Class 4. Low Boy and Oil Distributors.

Class 5. Drivers who require special protective clothing while employed on hazardous waste work.

TRUCK DRIVER - OIL AND CHIP RESEALING ONLY.

This shall encompass laborers, workers and mechanics who drive contractor or subcontractor owned, leased, or hired pickup, dump, service, or oil distributor trucks. The work includes transporting materials and equipment (including but not limited to, oils, aggregate supplies, parts, machinery and tools) to or from the job site; distributing oil or liquid asphalt and aggregate; stock piling material when in connection with the actual oil and chip contract. The Truck Driver (Oil & Chip Resealing) wage classification does not include supplier delivered materials.

Other Classifications of Work:

For definitions of classifications not otherwise set out, the Department generally has on file such definitions which are available. If a task to be performed is not subject to one of the classifications of pay set out, the Department will upon being contacted state which neighboring county has such a classification and provide such rate, such rate being deemed to exist by reference in this document. If no neighboring county rate applies to the task, the Department shall undertake a special determination, such special determination being then deemed to have existed under this determination. If a project requires these, or any classification not listed, please contact IDOL at 217-782-1710 for wage rates or clarifications.

LANDSCAPING

Landscaping work falls under the existing classifications for laborer, operating engineer and truck driver. The work performed by landscape plantsman and landscape laborer is covered by the existing classification of laborer. The work performed by landscape operators (regardless of equipment used or its size) is covered by the classifications of operating engineer. The work performed by landscape truck drivers (regardless of size of truck driven) is covered by the classifications of truck driver.

Jersey County Prevailing Wage for May 2012

(See explanation of column headings at bottom of wages)

| Trade Name | RG | TYP | C | Base | FRMAN | *M-F>8 | OSA | OSH | H/W | Pensn | Vac | Trng |
|----------------------|----|-----|---|--------|--------|--------|-----|-----|-------|-------|-------|-------|
| ===== | == | === | = | ===== | ===== | ===== | === | === | ===== | ===== | ===== | ===== |
| ASBESTOS ABT-GEN | | ALL | | 29.510 | 30.010 | 1.5 | 1.5 | 2.0 | 5.750 | 9.440 | 0.000 | 0.800 |
| ASBESTOS ABT-MEC | | BLD | | 29.160 | 30.160 | 1.5 | 1.5 | 2.0 | 6.700 | 2.750 | 0.000 | 0.000 |
| BOILERMAKER | | BLD | | 31.500 | 34.000 | 1.5 | 1.5 | 2.0 | 7.070 | 18.73 | 1.000 | 0.350 |
| BRICK MASON | | BLD | | 28.790 | 30.640 | 1.5 | 1.5 | 2.0 | 7.500 | 9.430 | 2.000 | 0.400 |
| CARPENTER | | ALL | | 33.880 | 35.380 | 1.5 | 1.5 | 2.0 | 6.300 | 6.250 | 0.000 | 0.400 |
| CEMENT MASON | | ALL | | 31.000 | 32.000 | 1.5 | 1.5 | 2.0 | 8.750 | 11.00 | 0.000 | 0.200 |
| CERAMIC TILE FNSHER | | BLD | | 25.520 | 0.000 | 1.5 | 1.5 | 2.0 | 5.900 | 5.110 | 0.000 | 0.470 |
| ELECTRIC PWR EQMT OP | | ALL | | 36.690 | 44.520 | 1.5 | 2.0 | 2.0 | 5.000 | 9.170 | 0.000 | 0.280 |
| ELECTRIC PWR GRNDMAN | | ALL | | 24.940 | 44.520 | 1.5 | 2.0 | 2.0 | 5.000 | 6.240 | 0.000 | 0.190 |
| ELECTRIC PWR LINEMAN | | ALL | | 42.210 | 44.520 | 1.5 | 2.0 | 2.0 | 5.000 | 10.56 | 0.000 | 0.320 |
| ELECTRIC PWR TRK DRV | | ALL | | 25.560 | 44.520 | 1.5 | 2.0 | 2.0 | 5.000 | 6.390 | 0.000 | 0.190 |
| ELECTRICIAN | | ALL | | 36.400 | 38.650 | 1.5 | 1.5 | 2.0 | 7.500 | 9.090 | 0.000 | 0.550 |
| ELECTRONIC SYS TECH | | BLD | | 28.740 | 30.490 | 1.5 | 1.5 | 2.0 | 7.500 | 5.860 | 0.000 | 0.400 |
| ELEVATOR CONSTRUCTOR | | BLD | | 43.345 | 48.760 | 2.0 | 2.0 | 2.0 | 11.03 | 11.96 | 2.600 | 0.000 |
| FLOOR LAYER | | BLD | | 29.080 | 29.830 | 1.5 | 1.5 | 2.0 | 6.300 | 6.250 | 0.000 | 0.400 |
| GLAZIER | | BLD | | 32.780 | 0.000 | 2.0 | 2.0 | 2.0 | 9.020 | 10.80 | 2.630 | 0.310 |
| HT/FROST INSULATOR | | BLD | | 36.760 | 37.760 | 1.5 | 1.5 | 2.0 | 7.550 | 10.76 | 0.000 | 0.500 |
| IRON WORKER | | ALL | | 31.000 | 33.000 | 1.5 | 1.5 | 2.0 | 7.110 | 12.35 | 0.000 | 0.420 |
| LABORER | | ALL | | 29.010 | 29.510 | 1.5 | 1.5 | 2.0 | 5.750 | 9.440 | 0.000 | 0.800 |
| MACHINIST | | BLD | | 43.160 | 45.160 | 1.5 | 1.5 | 2.0 | 7.980 | 8.950 | 0.000 | 0.000 |
| MARBLE FINISHERS | | BLD | | 25.520 | 0.000 | 1.5 | 1.5 | 2.0 | 5.900 | 5.110 | 0.000 | 0.470 |
| MILLWRIGHT | | ALL | | 33.880 | 35.380 | 1.5 | 1.5 | 2.0 | 6.300 | 6.250 | 0.000 | 0.400 |
| OPERATING ENGINEER | | BLD | 1 | 33.650 | 36.650 | 1.5 | 1.5 | 2.0 | 8.400 | 16.50 | 0.000 | 1.000 |
| OPERATING ENGINEER | | BLD | 2 | 32.520 | 36.650 | 1.5 | 1.5 | 2.0 | 8.400 | 16.50 | 0.000 | 1.000 |
| OPERATING ENGINEER | | BLD | 3 | 28.040 | 36.650 | 1.5 | 1.5 | 2.0 | 8.400 | 16.50 | 0.000 | 1.000 |
| OPERATING ENGINEER | | BLD | 4 | 28.100 | 36.650 | 1.5 | 1.5 | 2.0 | 8.400 | 16.50 | 0.000 | 1.000 |
| OPERATING ENGINEER | | BLD | 5 | 27.770 | 36.650 | 1.5 | 1.5 | 2.0 | 8.400 | 16.50 | 0.000 | 1.000 |
| OPERATING ENGINEER | | BLD | 6 | 34.200 | 36.650 | 1.5 | 1.5 | 2.0 | 8.400 | 16.50 | 0.000 | 1.000 |
| OPERATING ENGINEER | | BLD | 7 | 34.500 | 36.650 | 1.5 | 1.5 | 2.0 | 8.400 | 16.50 | 0.000 | 1.000 |
| OPERATING ENGINEER | | BLD | 8 | 34.780 | 36.650 | 1.5 | 1.5 | 2.0 | 8.400 | 16.50 | 0.000 | 1.000 |
| OPERATING ENGINEER | | BLD | 9 | 35.650 | 36.650 | 1.5 | 1.5 | 2.0 | 8.400 | 16.50 | 0.000 | 1.000 |
| OPERATING ENGINEER | | HWY | 1 | 32.150 | 35.150 | 1.5 | 1.5 | 2.0 | 8.400 | 16.50 | 0.000 | 1.000 |
| OPERATING ENGINEER | | HWY | 2 | 31.020 | 35.150 | 1.5 | 1.5 | 2.0 | 8.400 | 16.50 | 0.000 | 1.000 |
| OPERATING ENGINEER | | HWY | 3 | 26.540 | 35.150 | 1.5 | 1.5 | 2.0 | 8.400 | 16.50 | 0.000 | 1.000 |
| OPERATING ENGINEER | | HWY | 4 | 26.600 | 35.150 | 1.5 | 1.5 | 2.0 | 8.400 | 16.50 | 0.000 | 1.000 |
| OPERATING ENGINEER | | HWY | 5 | 26.270 | 35.150 | 1.5 | 1.5 | 2.0 | 8.400 | 16.50 | 0.000 | 1.000 |
| OPERATING ENGINEER | | HWY | 6 | 32.700 | 35.150 | 1.5 | 1.5 | 2.0 | 8.400 | 16.50 | 0.000 | 1.000 |
| OPERATING ENGINEER | | HWY | 7 | 33.000 | 35.150 | 1.5 | 1.5 | 2.0 | 8.400 | 16.50 | 0.000 | 1.000 |
| OPERATING ENGINEER | | HWY | 8 | 33.280 | 35.150 | 1.5 | 1.5 | 2.0 | 8.400 | 16.50 | 0.000 | 1.000 |
| OPERATING ENGINEER | | HWY | 9 | 34.150 | 35.150 | 1.5 | 1.5 | 2.0 | 8.400 | 16.50 | 0.000 | 1.000 |
| PAINTER | | BLD | | 29.250 | 30.750 | 1.5 | 1.5 | 2.0 | 5.000 | 7.920 | 0.000 | 0.600 |
| PAINTER | | HWY | | 30.450 | 31.950 | 1.5 | 1.5 | 2.0 | 5.000 | 7.920 | 0.000 | 0.600 |
| PAINTER OVER 30FT | | BLD | | 30.250 | 31.750 | 1.5 | 1.5 | 2.0 | 5.000 | 7.920 | 0.000 | 0.600 |
| PAINTER PWR EQMT | | BLD | | 30.250 | 31.750 | 1.5 | 1.5 | 2.0 | 5.000 | 7.920 | 0.000 | 0.600 |
| PAINTER PWR EQMT | | HWY | | 31.450 | 32.950 | 1.5 | 1.5 | 2.0 | 5.000 | 7.920 | 0.000 | 0.600 |
| PILEDRIVER | | ALL | | 33.880 | 35.380 | 1.5 | 1.5 | 2.0 | 6.300 | 6.250 | 0.000 | 0.400 |
| PIPEFITTER | | BLD | | 35.800 | 37.590 | 2.0 | 2.0 | 2.0 | 4.400 | 8.360 | 0.000 | 0.200 |
| PLASTERER | | BLD | | 30.250 | 31.250 | 1.5 | 1.5 | 2.0 | 8.750 | 8.300 | 0.000 | 0.050 |
| PLUMBER | | BLD | | 35.800 | 37.590 | 2.0 | 2.0 | 2.0 | 4.400 | 8.360 | 0.000 | 0.200 |
| ROOFER | | BLD | | 28.650 | 30.650 | 1.5 | 1.5 | 2.0 | 8.150 | 6.650 | 0.000 | 0.200 |
| SHEETMETAL WORKER | | ALL | | 31.690 | 33.190 | 1.5 | 1.5 | 2.0 | 7.130 | 6.730 | 1.910 | 0.360 |
| SPRINKLER FITTER | | BLD | | 37.830 | 40.830 | 2.0 | 2.0 | 2.0 | 8.550 | 10.35 | 0.000 | 0.850 |
| TERRAZZO FINISHER | | BLD | | 31.240 | 0.000 | 1.5 | 1.5 | 2.0 | 5.900 | 2.730 | 0.000 | 0.130 |
| TERRAZZO MASON | | BLD | | 32.530 | 32.830 | 1.5 | 1.5 | 2.0 | 5.900 | 4.980 | 0.000 | 0.140 |
| TRUCK DRIVER | | ALL | 1 | 30.460 | 0.000 | 1.5 | 1.5 | 2.0 | 10.05 | 4.775 | 0.000 | 0.250 |
| TRUCK DRIVER | | ALL | 2 | 30.890 | 0.000 | 1.5 | 1.5 | 2.0 | 10.05 | 4.775 | 0.000 | 0.250 |
| TRUCK DRIVER | | ALL | 3 | 31.120 | 0.000 | 1.5 | 1.5 | 2.0 | 10.05 | 4.775 | 0.000 | 0.250 |

| | | | | | | | | | | | |
|--------------|-----|---|--------|-------|-----|-----|-----|-------|-------|-------|-------|
| TRUCK DRIVER | ALL | 4 | 31.380 | 0.000 | 1.5 | 1.5 | 2.0 | 10.05 | 4.775 | 0.000 | 0.250 |
| TRUCK DRIVER | ALL | 5 | 32.200 | 0.000 | 1.5 | 1.5 | 2.0 | 10.05 | 4.775 | 0.000 | 0.250 |
| TRUCK DRIVER | O&C | 1 | 24.370 | 0.000 | 1.5 | 1.5 | 2.0 | 10.05 | 4.775 | 0.000 | 0.250 |
| TRUCK DRIVER | O&C | 2 | 24.710 | 0.000 | 1.5 | 1.5 | 2.0 | 10.05 | 4.775 | 0.000 | 0.250 |
| TRUCK DRIVER | O&C | 3 | 24.900 | 0.000 | 1.5 | 1.5 | 2.0 | 10.05 | 4.775 | 0.000 | 0.250 |
| TRUCK DRIVER | O&C | 4 | 25.100 | 0.000 | 1.5 | 1.5 | 2.0 | 10.05 | 4.775 | 0.000 | 0.250 |
| TRUCK DRIVER | O&C | 5 | 25.760 | 0.000 | 1.5 | 1.5 | 2.0 | 10.05 | 4.775 | 0.000 | 0.250 |

Legend :

RG (Region)

TYP (Trade Type - All,Highway,Building,Floating,Oil & Chip,Rivers)

C (Class)

Base (Base Wage Rate)

FRMAN (Foreman Rate)

M-F>8 (OT required for any hour greater than 8 worked each day, Mon through Fri.

OSA (Overtime (OT) is required for every hour worked on Saturday)

OSH (Overtime is required for every hour worked on Sunday and Holidays)

H/W (Health & Welfare Insurance)

Pensn (Pension)

Vac (Vacation)

Trng (Training)

Explanations

JERSEY COUNTY

The following list is considered as those days for which holiday rates of wages for work performed apply: New Years Day, Memorial Day, Fourth of July, Labor Day, Thanksgiving Day, Christmas Day and Veterans Day in some classifications/counties. Generally, any of these holidays which fall on a Sunday is celebrated on the following Monday. This then makes work performed on that Monday payable at the appropriate overtime rate for holiday pay. Common practice in a given local may alter certain days of celebration. If in doubt, please check with IDOL.

Oil and chip resealing (O&C) means the application of road oils and liquid asphalt to coat an existing road surface, followed by application of aggregate chips or gravel to coated surface, and subsequent rolling of material to seal the surface.

EXPLANATION OF CLASSES

ASBESTOS - GENERAL - removal of asbestos material/mold and hazardous materials from any place in a building, including mechanical systems where those mechanical systems are to be removed. This includes the removal of asbestos materials/mold and hazardous materials from ductwork or pipes in a building when the building is to be demolished at the time or at some close future date.

ASBESTOS - MECHANICAL - removal of asbestos material from mechanical systems, such as pipes, ducts, and boilers, where the mechanical systems are to remain.

CERAMIC TILE FINISHER AND MARBLE FINISHER

The handling, at the building site, of all sand, cement, tile, marble or stone and all other materials that may be used and installed by [a] tile layer or marble mason. In addition, the grouting, cleaning, sealing, and mixing on the job site, and all other work as required in assisting the setter. The term "Ceramic" is used for naming the classification only and is in no way a limitation of the product handled. Ceramic takes into consideration most hard tiles.

ELECTRONIC SYSTEMS TECHNICIAN

Installation, service and maintenance of low-voltage systems which utilizes the transmission and/or transference of voice, sound, vision, or digital for commercial, education, security and entertainment purposes for the following: TV monitoring and surveillance, background/foreground music, intercom and telephone interconnect, field programming, inventory control systems, microwave transmission, multi-media, multiplex, radio page, school, intercom and sound burglar alarms and low voltage master clock systems.

Excluded from this classification are energy management systems, life safety systems, supervisory controls and data acquisition systems not intrinsic with the above listed systems, fire alarm systems, nurse call systems and raceways exceeding fifteen feet in length.

OPERATING ENGINEER - BUILDING

GROUP I. Cranes, Dragline, Shovels, Skimmer Scoops, Clamshells or Derrick Boats, Pile Drivers, Crane-Type Backhoes, Asphalt Plant Operators, Concrete Plant Operators, Dredges, Asphalt Spreading Machines, All Locomotives, Cable Ways or Tower Machines, Hoists, Hydraulic Backhoes, Ditching Machines or Backfiller, Cherrypickers, Overhead Cranes, Roller - Steam or Gas, Concrete Pavers, Excavators, Concrete Breakers, Concrete Pumps, Bulk Cement Plants, Cement Pumps, Derrick-Type Drills, Boat Operators, Motor Graders or Pushcats, Scoops or Tournapulls, Bulldozers, Endloaders or Fork Lifts, Power Blade or Elevating Graders, Winch Cats, Boom or Winch Trucks or Boom Tractors, Pipe Wrapping or Painting Machines, Asphalt Plant Engineer, Journeyman Lubricating Engineer, Drills (other than Derrick Type), Mud Jacks, or Well Drilling Machines, Boring Machines or Track Jacks, Mixers, Conveyors (Two), Air Compressors (Two), Water Pumps regardless of size (Two), Welding Machines (Two), Siphons or Jets (Two), Winch Heads or Apparatuses (Two), Light Plants (Two), All Tractors regardless of size (straight tractor only), Fireman on Stationary Boilers, Automatic Elevators, Form Grading Machines, Finishing Machines, Power Sub-Grader or Ribbon Machines, Longitudinal Floats, Distributor Operators on Trucks, Winch Heads or Apparatuses (One), Mobil Track air and heaters (two to five), Heavy Equipment Greaser, Relief Operator, Assistant Master Mechanic and Heavy Duty Mechanic, self-propelled concrete saws

of all types and sizes with their attachments, gob-hoppers, excavators all sizes, the repair and greasing of all diesel hammers, the operation and set-up of bidwells, water blasters of all sizes and their clutches, hydraulic jacks where used for hoisting, operation of log skidders, iceolators used on and off of pipeline, condor cranes, bow boats, survey boats, bobcats and all their attachments, skid steer loaders and all their attachments, creter cranes, batch plants, operator (all sizes), self propelled roto mills, operation of conveyor systems of any size and any configuration, operation, repair and service of all vibratory hammers, all power pacs and their controls regardless of location, curtains or brush burning machines, stump cutter machines, Nail launchers when mounted on a machine or self-propelled, operation of con-cover machines, and all Operators except those listed below).

GROUP II. Assistant Operators.

GROUP III. Air Compressors (One), Water Pumps, regardless of Size (One), Waterblasters (one), Welding Machine (One), Mixers (One Bag), Conveyor (One), Siphon or Jet (One), Light Plant (One), Heater (One), Immobile Track Air (One), and Self Propelled Walk-Behind Rollers.

GROUP IV. Asphalt Spreader Oilers, Fireman on Whirlies and Heavy Equipment Oilers, Truck Cranes, Dredges, Monigans, Large Cranes - (Over 65-ton rated capacity) Concrete Plant Oiler, Blacktop Plant Oiler, and Creter Crane Oiler (when required).

GROUP V. Oiler.

GROUP VI. Operators on equipment with Booms, including jibs, 100 feet and over, and less than 150 feet long.

GROUP VII. Operators on equipment with Booms, including jibs, 150 feet and over, and less than 200 feet long.

GROUP VIII. Operators on Equipment with Booms, including jibs, 200 feet and over; Tower Cranes; and Whirlie Cranes.

GROUP IX. Master Mechanic

OPERATING ENGINEERS - Highway

GROUP I. Cranes, Dragline, Shovels, Skimmer Scoops, Clamshells or Derrick Boats, Pile Drivers, Crane-Type Backhoes, Asphalt Plant Operators, Concrete Plant Operators, Dredges, Asphalt Spreading Machines, All Locomotives, Cable Ways or Tower Machines, Hoists, Hydraulic Backhoes, Ditching Machines or Backfiller, Cherrypickers, Overhead Cranes, Roller - Steam or Gas, Concrete Pavers, Excavators, Concrete Breakers, Concrete Pumps, Bulk Cement Plants, Cement Pumps, Derrick-Type Drills, Boat Operators, Motor Graders or Pushcats, Scoops or Tournapulls, Bulldozers, Endloaders or Fork Lifts, Power Blade or Elevating Graders, Winch Cats, Boom or Winch Trucks or Boom Tractors, Pipe Wrapping or Painting Machines, Asphalt Plant Engineer, Journeyman Lubricating Engineer, Drills (other than Derrick Type), Mud Jacks, Well Drilling Machines, Boring Machines, Track Jacks, Mixers, Conveyors (Two), Air Compressors (Two), Water Pumps regardless of size (Two), Welding Machines (Two), Siphons or Jets (Two), Winch Heads or Apparatuses (Two), Light Plants (Two), All Tractors regardless of size (straight tractor only), Fireman on Stationary Boilers, Automatic Elevators, Form Grading Machines, Finishing Machines, Power Sub-Grader or Ribbon Machines, Longitudinal Floats, Distributor Operators on Trucks, Winch Heads or Apparatuses (One), Mobil Track air and heaters (two to five), Heavy Equipment Greaser, Relief Operator, Assistant

Master Mechanic and Heavy Duty Mechanic, self-propelled concrete saws of all types and sizes with their attachments, gob-hoppers, excavators all sizes, the repair and greasing of all diesel hammers, the operation and set-up of bidwells, water blasters of all sizes and their clutches, hydraulic jacks where used for hoisting, operation of log skidders, iceolators used on and off of pipeline, condor cranes, bow boats, survey boats, bobcats and all their attachments, skid steer loaders and all their attachments, creter cranes, batch plants, operator (all sizes), self propelled roto mills, operation of conveyer systems of any size and any configuration, operation, repair and service of all vibratory hammers, all power pacs and their controls regardless of location, curtains or brush burning machines, stump cutter machines, Nail launchers when mounted on a machine or self-propelled, operation of con-cover machines, and all Operators (except those listed below).

GROUP II. Assistant Operators.

GROUP III. Air Compressors (One), Water Pumps, regardless of Size (One), Waterblasters (one), Welding Machine (One), Mixers (One Bag), Conveyor (One), Siphon or Jet (One), Light Plant (One), Heater (One), Immobile Track Air (One), and Self Propelled Walk-Behind Rollers.

GROUP IV. Asphalt Spreader Oilers, Fireman on Whirlies and Heavy Equipment Oilers, Truck Cranes, Dredges, Monigans, Large Cranes - (Over 65-ton rated capacity) Concrete Plant Oiler, Blacktop Plant Oiler, and Creter Crane Oiler (when required).

GROUP V. Oiler.

GROUP VI. Operators on equipment with Booms, including jibs, 100 feet and over, and less than 150 feet long.

GROUP VII. Operators on equipment with Booms, including jibs, 150 feet and over, and less than 200 feet long.

GROUP VIII. Operators on Equipment with Booms, including jibs, 200 feet and over; Tower Cranes; and Whirlie Cranes.

GROUP IX. Mechanic

TRUCK DRIVER - BUILDING, HEAVY AND HIGHWAY CONSTRUCTION

Class 1. Drivers on 2 axle trucks hauling less than 9 ton. Air compressor and welding machines and brooms, including those pulled by separate units, truck driver helpers, warehouse employees, mechanic helpers, greasers and tiremen, pickup trucks when hauling materials, tools, or workers to and from and on-the-job site, and fork lifts up to 6,000 lb. capacity.

Class 2. Two or three axle trucks hauling more than 9 ton but hauling less than 16 ton. A-frame winch trucks, hydrolift trucks, vactor trucks or similar equipment when used for transportation purposes. Fork lifts over 6,000 lb. capacity, winch trucks, four axle combination units, and ticket writers.

Class 3. Two, three or four axle trucks hauling 16 ton or more. Drivers on water pulls, articulated dump trucks, mechanics and working forepersons, and dispatchers. Five axle or more combination units.

Class 4. Low Boy and Oil Distributors.

Class 5. Drivers who require special protective clothing while employed on hazardous waste work.

TRUCK DRIVER - OIL AND CHIP RESEALING ONLY.

This shall encompass laborers, workers and mechanics who drive contractor or subcontractor owned, leased, or hired pickup, dump, service, or oil distributor trucks. The work includes transporting materials and equipment (including but not limited to, oils, aggregate supplies, parts, machinery and tools) to or from the job site; distributing oil or liquid asphalt and aggregate; stock piling material when in connection with the actual oil and chip contract. The Truck Driver (Oil & Chip Resealing) wage classification does not include supplier delivered materials.

TERRAZZO FINISHER

The handling of all materials used for Mosaic and Terrazzo work including preparing, mixing by hand, by mixing machine or transporting of pre-mixed materials and distributing with shovel, rake, hoe, or pail, all kinds of concrete foundations necessary for Mosaic and Terrazzo work, all cement terrazzo, magnesite terrazzo, Do-O-Tex terrazzo, epoxy matrix terrazzo, exposed aggregate, rustic or rough washed for exterior or interior of buildings placed either by machine or by hand, and any other kind of mixture of plastics composed of chips or granules when mixed with cement, rubber, neoprene, vinyl, magnesium chloride or any other resinous or chemical substances used for seamless flooring systems, and all other building materials, all similar materials and all precast terrazzo work on jobs, all scratch coat used for Mosaic and Terrazzo work and sub-bed, tar paper and wire mesh (2x2 etc.) or lath. The rubbing, grinding, cleaning and finishing of same either by hand or by machine or by terrazzo resurfacing equipment on new or existing floors. When necessary finishers shall be allowed to assist the mechanics to spread sand bed, lay tarpaper and wire mesh (2x2 etc.) or lath. The finishing of cement floors where additional aggregate of stone is added by spreading or sprinkling on top of the finished base, and troweled or rolled into the finish and then the surface is ground by grinding machines.

Other Classifications of Work:

For definitions of classifications not otherwise set out, the Department generally has on file such definitions which are available. If a task to be performed is not subject to one of the classifications of pay set out, the Department will upon being contacted state which neighboring county has such a classification and provide such rate, such rate being deemed to exist by reference in this document. If no neighboring county rate applies to the task, the Department shall undertake a special determination, such special determination being then deemed to have existed under this determination. If a project requires these, or any classification not listed, please contact IDOL at 217-782-1710 for wage rates or clarifications.

LANDSCAPING

Landscaping work falls under the existing classifications for laborer, operating engineer and truck driver. The work performed by landscape plantsman and landscape laborer is covered by the existing classification of laborer. The work performed by landscape operators

(regardless of equipment used or its size) is covered by the classifications of operating engineer. The work performed by landscape truck drivers (regardless of size of truck driven) is covered by the classifications of truck driver.

Madison County Prevailing Wage for May 2012

(See explanation of column headings at bottom of wages)

| Trade Name | RG | TYP | C | Base | FRMAN | *M-F>8 | OSA | OSH | H/W | Pensn | Vac | Trng |
|----------------------|----|-----|---|--------|--------|--------|-----|-----|-------|-------|-------|-------|
| ===== | == | === | = | ===== | ===== | ===== | === | === | ===== | ===== | ===== | ===== |
| ASBESTOS ABT-GEN | NW | ALL | | 29.510 | 30.010 | 1.5 | 1.5 | 2.0 | 5.750 | 9.440 | 0.000 | 0.800 |
| ASBESTOS ABT-GEN | SE | ALL | | 28.800 | 29.300 | 1.5 | 1.5 | 2.0 | 5.550 | 10.35 | 0.000 | 0.800 |
| ASBESTOS ABT-MEC | | BLD | | 29.160 | 30.160 | 1.5 | 1.5 | 2.0 | 6.700 | 2.750 | 0.000 | 0.000 |
| BOILERMAKER | | BLD | | 31.500 | 34.000 | 1.5 | 1.5 | 2.0 | 7.070 | 18.73 | 1.000 | 0.350 |
| BRICK MASON | | BLD | | 28.790 | 30.640 | 1.5 | 1.5 | 2.0 | 7.500 | 9.430 | 2.000 | 0.400 |
| CARPENTER | | ALL | | 33.880 | 35.380 | 1.5 | 1.5 | 2.0 | 6.300 | 6.250 | 0.000 | 0.400 |
| CEMENT MASON | | ALL | | 31.000 | 32.000 | 1.5 | 1.5 | 2.0 | 8.750 | 11.00 | 0.000 | 0.200 |
| CERAMIC TILE FNSHER | | BLD | | 25.520 | 0.000 | 1.5 | 1.5 | 2.0 | 5.900 | 5.110 | 0.000 | 0.470 |
| ELECTRIC PWR EQMT OP | NW | ALL | | 36.690 | 44.520 | 1.5 | 2.0 | 2.0 | 5.000 | 9.170 | 0.000 | 0.280 |
| ELECTRIC PWR EQMT OP | SE | ALL | | 34.800 | 0.000 | 1.5 | 2.0 | 2.0 | 5.850 | 9.750 | 0.000 | 0.260 |
| ELECTRIC PWR GRNDMAN | NW | ALL | | 24.940 | 44.520 | 1.5 | 2.0 | 2.0 | 5.000 | 6.240 | 0.000 | 0.190 |
| ELECTRIC PWR GRNDMAN | SE | ALL | | 25.980 | 0.000 | 1.5 | 2.0 | 2.0 | 4.370 | 7.280 | 0.000 | 0.190 |
| ELECTRIC PWR LINEMAN | NW | ALL | | 42.210 | 44.520 | 1.5 | 2.0 | 2.0 | 5.000 | 10.56 | 0.000 | 0.320 |
| ELECTRIC PWR LINEMAN | SE | ALL | | 40.020 | 41.950 | 1.5 | 2.0 | 2.0 | 6.720 | 11.21 | 0.000 | 0.300 |
| ELECTRIC PWR TRK DRV | NW | ALL | | 25.560 | 44.520 | 1.5 | 2.0 | 2.0 | 5.000 | 6.390 | 0.000 | 0.190 |
| ELECTRIC PWR TRK DRV | SE | ALL | | 28.410 | 0.000 | 1.5 | 2.0 | 2.0 | 4.780 | 7.950 | 0.000 | 0.210 |
| ELECTRICIAN | NW | ALL | | 36.400 | 38.650 | 1.5 | 1.5 | 2.0 | 7.500 | 9.090 | 0.000 | 0.550 |
| ELECTRICIAN | SE | ALL | | 36.510 | 38.700 | 1.5 | 1.5 | 2.0 | 7.210 | 7.490 | 0.000 | 0.640 |
| ELECTRONIC SYS TECH | NW | BLD | | 28.740 | 30.490 | 1.5 | 1.5 | 2.0 | 7.500 | 5.860 | 0.000 | 0.400 |
| ELECTRONIC SYS TECH | SE | BLD | | 29.920 | 31.670 | 1.5 | 1.5 | 2.0 | 3.200 | 7.400 | 0.000 | 0.250 |
| ELEVATOR CONSTRUCTOR | | BLD | | 43.345 | 48.760 | 2.0 | 2.0 | 2.0 | 11.03 | 11.96 | 2.600 | 0.000 |
| FLOOR LAYER | | BLD | | 29.080 | 29.830 | 1.5 | 1.5 | 2.0 | 6.300 | 6.250 | 0.000 | 0.400 |
| GLAZIER | | BLD | | 32.780 | 0.000 | 2.0 | 2.0 | 2.0 | 9.020 | 10.80 | 2.630 | 0.310 |
| HT/FROST INSULATOR | | BLD | | 36.760 | 37.760 | 1.5 | 1.5 | 2.0 | 7.550 | 10.76 | 0.000 | 0.500 |
| IRON WORKER | | ALL | | 31.000 | 33.000 | 1.5 | 1.5 | 2.0 | 7.110 | 12.35 | 0.000 | 0.420 |
| LABORER | NW | ALL | | 29.010 | 29.510 | 1.5 | 1.5 | 2.0 | 5.750 | 9.440 | 0.000 | 0.800 |
| LABORER | SE | ALL | | 28.300 | 28.800 | 1.5 | 1.5 | 2.0 | 5.550 | 10.35 | 0.000 | 0.800 |
| MACHINIST | | BLD | | 43.160 | 45.160 | 1.5 | 1.5 | 2.0 | 7.980 | 8.950 | 0.000 | 0.000 |
| MARBLE FINISHERS | | BLD | | 25.520 | 0.000 | 1.5 | 1.5 | 2.0 | 5.900 | 5.110 | 0.000 | 0.470 |
| MARBLE MASON | | BLD | | 28.790 | 30.640 | 1.5 | 1.5 | 2.0 | 7.500 | 9.430 | 2.000 | 0.400 |
| MILLWRIGHT | | ALL | | 33.880 | 35.380 | 1.5 | 1.5 | 2.0 | 6.300 | 6.250 | 0.000 | 0.400 |
| OPERATING ENGINEER | | BLD | 1 | 33.650 | 36.650 | 1.5 | 1.5 | 2.0 | 8.400 | 16.50 | 0.000 | 1.000 |
| OPERATING ENGINEER | | BLD | 2 | 32.520 | 36.650 | 1.5 | 1.5 | 2.0 | 8.400 | 16.50 | 0.000 | 1.000 |
| OPERATING ENGINEER | | BLD | 3 | 28.040 | 36.650 | 1.5 | 1.5 | 2.0 | 8.400 | 16.50 | 0.000 | 1.000 |
| OPERATING ENGINEER | | BLD | 4 | 28.100 | 36.650 | 1.5 | 1.5 | 2.0 | 8.400 | 16.50 | 0.000 | 1.000 |
| OPERATING ENGINEER | | BLD | 5 | 27.770 | 36.650 | 1.5 | 1.5 | 2.0 | 8.400 | 16.50 | 0.000 | 1.000 |
| OPERATING ENGINEER | | BLD | 6 | 34.200 | 36.650 | 1.5 | 1.5 | 2.0 | 8.400 | 16.50 | 0.000 | 1.000 |
| OPERATING ENGINEER | | BLD | 7 | 34.500 | 36.650 | 1.5 | 1.5 | 2.0 | 8.400 | 16.50 | 0.000 | 1.000 |
| OPERATING ENGINEER | | BLD | 8 | 34.780 | 36.650 | 1.5 | 1.5 | 2.0 | 8.400 | 16.50 | 0.000 | 1.000 |
| OPERATING ENGINEER | | BLD | 9 | 35.650 | 36.650 | 1.5 | 1.5 | 2.0 | 8.400 | 16.50 | 0.000 | 1.000 |
| OPERATING ENGINEER | | HWY | 1 | 32.150 | 35.150 | 1.5 | 1.5 | 2.0 | 8.400 | 16.50 | 0.000 | 1.000 |
| OPERATING ENGINEER | | HWY | 2 | 31.020 | 35.150 | 1.5 | 1.5 | 2.0 | 8.400 | 16.50 | 0.000 | 1.000 |
| OPERATING ENGINEER | | HWY | 3 | 26.540 | 35.150 | 1.5 | 1.5 | 2.0 | 8.400 | 16.50 | 0.000 | 1.000 |
| OPERATING ENGINEER | | HWY | 4 | 26.600 | 35.150 | 1.5 | 1.5 | 2.0 | 8.400 | 16.50 | 0.000 | 1.000 |
| OPERATING ENGINEER | | HWY | 5 | 26.270 | 35.150 | 1.5 | 1.5 | 2.0 | 8.400 | 16.50 | 0.000 | 1.000 |
| OPERATING ENGINEER | | HWY | 6 | 32.700 | 35.150 | 1.5 | 1.5 | 2.0 | 8.400 | 16.50 | 0.000 | 1.000 |
| OPERATING ENGINEER | | HWY | 7 | 33.000 | 35.150 | 1.5 | 1.5 | 2.0 | 8.400 | 16.50 | 0.000 | 1.000 |
| OPERATING ENGINEER | | HWY | 8 | 33.280 | 35.150 | 1.5 | 1.5 | 2.0 | 8.400 | 16.50 | 0.000 | 1.000 |
| OPERATING ENGINEER | | HWY | 9 | 34.150 | 35.150 | 1.5 | 1.5 | 2.0 | 8.400 | 16.50 | 0.000 | 1.000 |
| PAINTER | | BLD | | 29.250 | 30.750 | 1.5 | 1.5 | 2.0 | 5.000 | 7.920 | 0.000 | 0.600 |
| PAINTER | | HWY | | 30.450 | 31.950 | 1.5 | 1.5 | 2.0 | 5.000 | 7.920 | 0.000 | 0.600 |
| PAINTER OVER 30FT | | BLD | | 30.250 | 31.750 | 1.5 | 1.5 | 2.0 | 5.000 | 7.920 | 0.000 | 0.600 |
| PAINTER PWR EQMT | | BLD | | 30.250 | 31.750 | 1.5 | 1.5 | 2.0 | 5.000 | 7.920 | 0.000 | 0.600 |
| PAINTER PWR EQMT | | HWY | | 31.450 | 32.950 | 1.5 | 1.5 | 2.0 | 5.000 | 7.920 | 0.000 | 0.600 |
| PILEDRIVER | | ALL | | 33.880 | 35.380 | 1.5 | 1.5 | 2.0 | 6.300 | 6.250 | 0.000 | 0.400 |
| PIPEFITTER | N | BLD | | 35.800 | 37.590 | 2.0 | 2.0 | 2.0 | 4.400 | 8.360 | 0.000 | 0.200 |
| PIPEFITTER | S | BLD | | 36.000 | 38.000 | 1.5 | 1.5 | 2.0 | 6.690 | 8.000 | 0.000 | 0.750 |

| | | | | | | | | | | | |
|-------------------|---|-------|--------|--------|-----|-----|-----|-------|-------|-------|-------|
| PLASTERER | | BLD | 30.250 | 31.250 | 1.5 | 1.5 | 2.0 | 8.750 | 8.300 | 0.000 | 0.050 |
| PLUMBER | N | BLD | 35.800 | 37.590 | 2.0 | 2.0 | 2.0 | 4.400 | 8.360 | 0.000 | 0.200 |
| PLUMBER | S | BLD | 35.150 | 37.650 | 1.5 | 1.5 | 2.0 | 6.000 | 6.600 | 0.000 | 0.400 |
| ROOFER | | BLD | 28.650 | 30.650 | 1.5 | 1.5 | 2.0 | 8.150 | 6.650 | 0.000 | 0.200 |
| SHEETMETAL WORKER | | ALL | 31.690 | 33.190 | 1.5 | 1.5 | 2.0 | 7.130 | 6.730 | 1.910 | 0.360 |
| SPRINKLER FITTER | | BLD | 37.830 | 40.830 | 2.0 | 2.0 | 2.0 | 8.550 | 10.35 | 0.000 | 0.850 |
| TERRAZZO FINISHER | | BLD | 31.240 | 0.000 | 1.5 | 1.5 | 2.0 | 5.900 | 2.730 | 0.000 | 0.130 |
| TERRAZZO MASON | | BLD | 32.530 | 32.830 | 1.5 | 1.5 | 2.0 | 5.900 | 4.980 | 0.000 | 0.140 |
| TRUCK DRIVER | | ALL 1 | 30.460 | 0.000 | 1.5 | 1.5 | 2.0 | 10.05 | 4.775 | 0.000 | 0.250 |
| TRUCK DRIVER | | ALL 2 | 30.890 | 0.000 | 1.5 | 1.5 | 2.0 | 10.05 | 4.775 | 0.000 | 0.250 |
| TRUCK DRIVER | | ALL 3 | 31.120 | 0.000 | 1.5 | 1.5 | 2.0 | 10.05 | 4.775 | 0.000 | 0.250 |
| TRUCK DRIVER | | ALL 4 | 31.380 | 0.000 | 1.5 | 1.5 | 2.0 | 10.05 | 4.775 | 0.000 | 0.250 |
| TRUCK DRIVER | | ALL 5 | 32.200 | 0.000 | 1.5 | 1.5 | 2.0 | 10.05 | 4.775 | 0.000 | 0.250 |
| TRUCK DRIVER | | O&C 1 | 24.370 | 0.000 | 1.5 | 1.5 | 2.0 | 10.05 | 4.775 | 0.000 | 0.250 |
| TRUCK DRIVER | | O&C 2 | 24.710 | 0.000 | 1.5 | 1.5 | 2.0 | 10.05 | 4.775 | 0.000 | 0.250 |
| TRUCK DRIVER | | O&C 3 | 24.900 | 0.000 | 1.5 | 1.5 | 2.0 | 10.05 | 4.775 | 0.000 | 0.250 |
| TRUCK DRIVER | | O&C 4 | 25.100 | 0.000 | 1.5 | 1.5 | 2.0 | 10.05 | 4.775 | 0.000 | 0.250 |
| TRUCK DRIVER | | O&C 5 | 25.760 | 0.000 | 1.5 | 1.5 | 2.0 | 10.05 | 4.775 | 0.000 | 0.250 |

Legend:

RG (Region)

TYP (Trade Type - All,Highway,Building,Floating,Oil & Chip,Rivers)

C (Class)

Base (Base Wage Rate)

FRMAN (Foreman Rate)

M-F>8 (OT required for any hour greater than 8 worked each day, Mon through Fri.

OSA (Overtime (OT) is required for every hour worked on Saturday)

OSH (Overtime is required for every hour worked on Sunday and Holidays)

H/W (Health & Welfare Insurance)

Pensn (Pension)

Vac (Vacation)

Trng (Training)

Explanations

MADISON COUNTY

ELECTRICIANS AND ELECTRIC SYSTEMS TECHNICIAN (NORTHWEST) - Townships of Godfrey, Foster and Wood River, and the western one mile of Moro,

Ft. Russell and Edwardsville, south to the north side of Hwy. 66 and west to the Mississippi River. This includes SIU-Edwardsville Dental Facility and Alton Mental Health Hospital.

ELECTRICIANS AND ELECTRIC SYSTEMS TECHNICIAN (SOUTHEAST) - Remainder of county not covered by ELECTRICIANS AND ELECTRIC SYSTEMS TECHNICIAN (NW) including SIU-Edwardsville Main Campus.

LABORERS (NORTHWEST) - That area northwest of a diagonal line running from the Mississippi River at the intersection of the waterway known as Wood River at Maple Island, northeast through the highway intersection of Illinois Routes 3 and 143 and following the boundary of Alton/East Alton, then preceding northeast to the county line at a point approximately one mile west of Illinois Route 159.

PLUMBERS AND PIPEFITTERS (SOUTH) - That part of the county South of a line between Mitchell and Highland including the town of Glen Carbon.

The following list is considered as those days for which holiday rates of wages for work performed apply: New Years Day, Memorial Day, Fourth of July, Labor Day, Thanksgiving Day, Christmas Day and Veterans Day in some classifications/counties. Generally, any of these holidays which fall on a Sunday is celebrated on the following Monday. This then makes work performed on that Monday payable at the appropriate overtime rate for holiday pay. Common practice in a given local may alter certain days of celebration. If in doubt, please check with IDOL.

Oil and chip resealing (O&C) means the application of road oils and liquid asphalt to coat an existing road surface, followed by application of aggregate chips or gravel to coated surface, and subsequent rolling of material to seal the surface.

EXPLANATION OF CLASSES

ASBESTOS - GENERAL - removal of asbestos material/mold and hazardous materials from any place in a building, including mechanical systems where those mechanical systems are to be removed. This includes the removal of asbestos materials/mold and hazardous materials from ductwork or pipes in a building when the building is to be demolished at the time or at some close future date.

ASBESTOS - MECHANICAL - removal of asbestos material from mechanical systems, such as pipes, ducts, and boilers, where the mechanical systems are to remain.

CERAMIC TILE FINISHER AND MARBLE FINISHER

The handling, at the building site, of all sand, cement, tile, marble or stone and all other materials that may be used and installed by [a] tile layer or marble mason. In addition, the grouting, cleaning, sealing, and mixing on the job site, and all other work as required in assisting the setter. The term "Ceramic" is used for naming the classification only and is in no way a limitation of the product handled. Ceramic takes into consideration most hard tiles.

ELECTRONIC SYSTEMS TECHNICIAN

Installation, service and maintenance of low-voltage systems which utilizes the transmission and/or transference of voice, sound, vision, or digital for commercial, education, security and entertainment purposes for the following: TV monitoring and surveillance,

background/foreground music, intercom and telephone interconnect, field programming, inventory control systems, microwave transmission, multi-media, multiplex, radio page, school, intercom and sound burglar alarms and low voltage master clock systems.

Excluded from this classification are energy management systems, life safety systems, supervisory controls and data acquisition systems not intrinsic with the above listed systems, fire alarm systems, nurse call systems and raceways exceeding fifteen feet in length.

OPERATING ENGINEER - BUILDING

GROUP I. Cranes, Dragline, Shovels, Skimmer Scoops, Clamshells or Derrick Boats, Pile Drivers, Crane-Type Backhoes, Asphalt Plant Operators, Concrete Plant Operators, Dredges, Asphalt Spreading Machines, All Locomotives, Cable Ways or Tower Machines, Hoists, Hydraulic Backhoes, Ditching Machines or Backfiller, Cherrypickers, Overhead Cranes, Roller - Steam or Gas, Concrete Pavers, Excavators, Concrete Breakers, Concrete Pumps, Bulk Cement Plants, Cement Pumps, Derrick-Type Drills, Boat Operators, Motor Graders or Pushcats, Scoops or Tournapulls, Bulldozers, Endloaders or Fork Lifts, Power Blade or Elevating Graders, Winch Cats, Boom or Winch Trucks or Boom Tractors, Pipe Wrapping or Painting Machines, Asphalt Plant Engineer, Journeyman Lubricating Engineer, Drills (other than Derrick Type), Mud Jacks, or Well Drilling Machines, Boring Machines or Track Jacks, Mixers, Conveyors (Two), Air Compressors (Two), Water Pumps regardless of size (Two), Welding Machines (Two), Siphons or Jets (Two), Winch Heads or Apparatuses (Two), Light Plants (Two), All Tractors regardless of size (straight tractor only), Fireman on Stationary Boilers, Automatic Elevators, Form Grading Machines, Finishing Machines, Power Sub-Grader or Ribbon Machines, Longitudinal Floats, Distributor Operators on Trucks, Winch Heads or Apparatuses (One), Mobil Track air and heaters (two to five), Heavy Equipment Greaser, Relief Operator, Assistant Master Mechanic and Heavy Duty Mechanic, self-propelled concrete saws of all types and sizes with their attachments, gob-hoppers, excavators all sizes, the repair and greasing of all diesel hammers, the operation and set-up of bidwells, water blasters of all sizes and their clutches, hydraulic jacks where used for hoisting, operation of log skidders, iceolators used on and off of pipeline, condor cranes, bow boats, survey boats, bobcats and all their attachments, skid steer loaders and all their attachments, creter cranes, batch plants, operator (all sizes), self propelled roto mills, operation of conveyor systems of any size and any configuration, operation, repair and service of all vibratory hammers, all power pacs and their controls regardless of location, curtains or brush burning machines, stump cutter machines, Nail launchers when mounted on a machine or self-propelled, operation of con-cover machines, and all Operators except those listed below).

GROUP II. Assistant Operators.

GROUP III. Air Compressors (One), Water Pumps, regardless of Size (One), Waterblasters (one), Welding Machine (One), Mixers (One Bag), Conveyor (One), Siphon or Jet (One), Light Plant (One), Heater (One), Immobile Track Air (One), and Self Propelled Walk-Behind Rollers.

GROUP IV. Asphalt Spreader Oilers, Fireman on Whirlies and Heavy Equipment Oilers, Truck Cranes, Dredges, Monigans, Large Cranes - (Over 65-ton rated capacity) Concrete Plant Oiler, Blacktop Plant Oiler, and Creter Crane Oiler (when required).

GROUP V. Oiler.

GROUP VI. Operators on equipment with Booms, including jibs, 100 feet and over, and less than 150 feet long.

GROUP VII. Operators on equipment with Booms, including jibs, 150 feet and over, and less than 200 feet long.

GROUP VIII. Operators on Equipment with Booms, including jibs, 200 feet and over; Tower Cranes; and Whirlie Cranes.

GROUP IX. Master Mechanic

OPERATING ENGINEERS - Highway

GROUP I. Cranes, Dragline, Shovels, Skimmer Scoops, Clamshells or Derrick Boats, Pile Drivers, Crane-Type Backhoes, Asphalt Plant Operators, Concrete Plant Operators, Dredges, Asphalt Spreading Machines, All Locomotives, Cable Ways or Tower Machines, Hoists, Hydraulic Backhoes, Ditching Machines or Backfiller, Cherrypickers, Overhead Cranes, Roller - Steam or Gas, Concrete Pavers, Excavators, Concrete Breakers, Concrete Pumps, Bulk Cement Plants, Cement Pumps, Derrick-Type Drills, Boat Operators, Motor Graders or Pushcats, Scoops or Tournapulls, Bulldozers, Endloaders or Fork Lifts, Power Blade or Elevating Graders, Winch Cats, Boom or Winch Trucks or Boom Tractors, Pipe Wrapping or Painting Machines, Asphalt Plant Engineer, Journeyman Lubricating Engineer, Drills (other than Derrick Type), Mud Jacks, Well Drilling Machines, Boring Machines, Track Jacks, Mixers, Conveyors (Two), Air Compressors (Two), Water Pumps regardless of size (Two), Welding Machines (Two), Siphons or Jets (Two), Winch Heads or Apparatuses (Two), Light Plants (Two), All Tractors regardless of size (straight tractor only), Fireman on Stationary Boilers, Automatic Elevators, Form Grading Machines, Finishing Machines, Power Sub-Grader or Ribbon Machines, Longitudinal Floats, Distributor Operators on Trucks, Winch Heads or Apparatuses (One), Mobil Track air and heaters (two to five), Heavy Equipment Greaser, Relief Operator, Assistant Master Mechanic and Heavy Duty Mechanic, self-propelled concrete saws of all types and sizes with their attachments, gob-hoppers, excavators all sizes, the repair and greasing of all diesel hammers, the operation and set-up of bidwells, water blasters of all sizes and their clutches, hydraulic jacks where used for hoisting, operation of log skidders, iceolators used on and off of pipeline, condor cranes, bow boats, survey boats, bobcats and all their attachments, skid steer loaders and all their attachments, creter cranes, batch plants, operator (all sizes), self propelled roto mills, operation of conveyor systems of any size and any configuration, operation, repair and service of all vibratory hammers, all power pacs and their controls regardless of location, curtains or brush burning machines, stump cutter machines, Nail launchers when mounted on a machine or self-propelled, operation of con-cover machines, and all Operators (except those listed below).

GROUP II. Assistant Operators.

GROUP III. Air Compressors (One), Water Pumps, regardless of Size (One), Waterblasters (one), Welding Machine (One), Mixers (One Bag), Conveyor (One), Siphon or Jet (One), Light Plant (One), Heater (One), Immobile Track Air (One), and Self Propelled Walk-Behind Rollers.

GROUP IV. Asphalt Spreader Oilers, Fireman on Whirlies and Heavy Equipment Oilers, Truck Cranes, Dredges, Monigans, Large Cranes - (Over 65-ton rated capacity) Concrete Plant Oiler, Blacktop Plant Oiler, and Creter Crane Oiler (when required).

GROUP V. Oiler.

GROUP VI. Operators on equipment with Booms, including jibs, 100 feet and over, and less than 150 feet long.

GROUP VII. Operators on equipment with Booms, including jibs, 150 feet and over, and less than 200 feet long.

GROUP VIII. Operators on Equipment with Booms, including jibs, 200 feet and over; Tower Cranes; and Whirlie Cranes.

GROUP IX. Mechanic

TRUCK DRIVER - BUILDING, HEAVY AND HIGHWAY CONSTRUCTION

Class 1. Drivers on 2 axle trucks hauling less than 9 ton. Air compressor and welding machines and brooms, including those pulled by separate units, truck driver helpers, warehouse employees, mechanic helpers, greasers and tiremen, pickup trucks when hauling materials, tools, or workers to and from and on-the-job site, and fork lifts up to 6,000 lb. capacity.

Class 2. Two or three axle trucks hauling more than 9 ton but hauling less than 16 ton. A-frame winch trucks, hydrolift trucks, vactor trucks or similar equipment when used for transportation purposes. Fork lifts over 6,000 lb. capacity, winch trucks, four axle combination units, and ticket writers.

Class 3. Two, three or four axle trucks hauling 16 ton or more. Drivers on water pulls, articulated dump trucks, mechanics and working forepersons, and dispatchers. Five axle or more combination units.

Class 4. Low Boy and Oil Distributors.

Class 5. Drivers who require special protective clothing while employed on hazardous waste work.

TRUCK DRIVER - OIL AND CHIP RESEALING ONLY.

This shall encompass laborers, workers and mechanics who drive contractor or subcontractor owned, leased, or hired pickup, dump, service, or oil distributor trucks. The work includes transporting materials and equipment (including but not limited to, oils, aggregate supplies, parts, machinery and tools) to or from the job site; distributing oil or liquid asphalt and aggregate; stock piling material when in connection with the actual oil and chip contract. The Truck Driver (Oil & Chip Resealing) wage classification does not include supplier delivered materials.

TERRAZZO FINISHER

The handling of all materials used for Mosaic and Terrazzo work including preparing, mixing by hand, by mixing machine or transporting of pre-mixed materials and distributing with shovel, rake, hoe, or pail, all kinds of concrete foundations necessary for Mosaic and Terrazzo work, all cement terrazzo, magnesite terrazzo, Do-O-Tex terrazzo, epoxy matrix ter-razzo, exposed aggregate, rustic or rough washed for exterior or interior of buildings placed either by machine or by hand, and any other kind of mixture of plastics composed of chips or granules when mixed with cement, rubber, neoprene, vinyl, magnesium chloride or any other resinous or chemical substances used

for seamless flooring systems, and all other building materials, all similar materials and all precast terrazzo work on jobs, all scratch coat used for Mosaic and Terrazzo work and sub-bed, tar paper and wire mesh (2x2 etc.) or lath. The rubbing, grinding, cleaning and finishing of same either by hand or by machine or by terrazzo resurfacing equipment on new or existing floors. When necessary finishers shall be allowed to assist the mechanics to spread sand bed, lay tarpaper and wire mesh (2x2 etc.) or lath. The finishing of cement floors where additional aggregate of stone is added by spreading or sprinkling on top of the finished base, and troweled or rolled into the finish and then the surface is ground by grinding machines.

Other Classifications of Work:

For definitions of classifications not otherwise set out, the Department generally has on file such definitions which are available. If a task to be performed is not subject to one of the classifications of pay set out, the Department will upon being contacted state which neighboring county has such a classification and provide such rate, such rate being deemed to exist by reference in this document. If no neighboring county rate applies to the task, the Department shall undertake a special determination, such special determination being then deemed to have existed under this determination. If a project requires these, or any classification not listed, please contact IDOL at 217-782-1710 for wage rates or clarifications.

LANDSCAPING

Landscaping work falls under the existing classifications for laborer, operating engineer and truck driver. The work performed by landscape plantsman and landscape laborer is covered by the existing classification of laborer. The work performed by landscape operators (regardless of equipment used or its size) is covered by the classifications of operating engineer. The work performed by landscape truck drivers (regardless of size of truck driven) is covered by the classifications of truck driver.

Marion County Prevailing Wage for May 2012

(See explanation of column headings at bottom of wages)

| Trade Name | RG | TYP | C | Base | FRMAN | *M-F>8 | OSA | OSH | H/W | Pensn | Vac | Trng |
|----------------------|----|-----|---|--------|--------|--------|-----|-----|-------|-------|-------|-------|
| ===== | == | === | = | ===== | ===== | ===== | === | === | ===== | ===== | ===== | ===== |
| ASBESTOS ABT-GEN | | ALL | | 25.300 | 25.750 | 1.5 | 1.5 | 2.0 | 5.750 | 10.35 | 0.000 | 0.900 |
| ASBESTOS ABT-MEC | | BLD | | 29.160 | 30.160 | 1.5 | 1.5 | 2.0 | 6.700 | 2.750 | 0.000 | 0.000 |
| BOILERMAKER | | BLD | | 31.500 | 34.000 | 1.5 | 1.5 | 2.0 | 7.070 | 18.73 | 1.000 | 0.350 |
| BRICK MASON | | BLD | | 28.790 | 30.640 | 1.5 | 1.5 | 2.0 | 7.500 | 9.430 | 2.000 | 0.400 |
| CARPENTER | | BLD | | 31.140 | 32.640 | 1.5 | 1.5 | 2.0 | 6.300 | 6.250 | 0.000 | 0.400 |
| CARPENTER | | HWY | | 31.140 | 32.890 | 1.5 | 1.5 | 2.0 | 6.300 | 6.250 | 0.000 | 0.400 |
| CEMENT MASON | | BLD | | 28.200 | 29.700 | 1.5 | 1.5 | 2.0 | 6.600 | 5.400 | 0.000 | 0.500 |
| CEMENT MASON | | HWY | | 26.080 | 27.580 | 1.5 | 1.5 | 2.0 | 6.400 | 5.470 | 0.000 | 0.300 |
| CERAMIC TILE FNSHER | | BLD | | 25.520 | 0.000 | 1.5 | 1.5 | 2.0 | 5.900 | 5.110 | 0.000 | 0.470 |
| ELECTRIC PWR EQMT OP | | ALL | 1 | 34.400 | 0.000 | 1.5 | 1.5 | 2.0 | 5.000 | 9.630 | 0.000 | 0.260 |
| ELECTRIC PWR EQMT OP | | ALL | 2 | 30.680 | 0.000 | 1.5 | 1.5 | 2.0 | 5.000 | 8.590 | 0.000 | 0.230 |
| ELECTRIC PWR GRNDMAN | | ALL | | 25.210 | 0.000 | 1.5 | 1.5 | 2.0 | 5.000 | 7.060 | 0.000 | 0.190 |
| ELECTRIC PWR LINEMAN | | ALL | | 43.200 | 46.130 | 1.5 | 1.5 | 2.0 | 5.000 | 12.10 | 0.000 | 0.320 |
| ELECTRICIAN | | ALL | | 37.930 | 40.180 | 1.5 | 1.5 | 2.0 | 5.350 | 9.110 | 0.000 | 0.760 |
| ELECTRONIC SYS TECH | | BLD | | 31.870 | 33.620 | 1.5 | 1.5 | 2.0 | 5.350 | 4.150 | 0.000 | 0.400 |
| FLOOR LAYER | | BLD | | 29.080 | 29.830 | 1.5 | 1.5 | 2.0 | 6.300 | 6.250 | 0.000 | 0.400 |
| GLAZIER | | BLD | | 32.780 | 0.000 | 2.0 | 2.0 | 2.0 | 9.020 | 10.80 | 2.630 | 0.310 |
| HT/FROST INSULATOR | | BLD | | 36.760 | 37.760 | 1.5 | 1.5 | 2.0 | 7.550 | 10.76 | 0.000 | 0.500 |
| IRON WORKER | | ALL | | 31.000 | 33.000 | 1.5 | 1.5 | 2.0 | 7.110 | 12.35 | 0.000 | 0.420 |
| LABORER | | BLD | | 25.300 | 25.750 | 1.5 | 1.5 | 2.0 | 5.750 | 10.35 | 0.000 | 0.800 |
| LABORER | | HWY | | 25.300 | 25.750 | 1.5 | 1.5 | 2.0 | 5.750 | 10.35 | 0.000 | 0.800 |
| MACHINIST | | BLD | | 43.160 | 45.160 | 1.5 | 1.5 | 2.0 | 7.980 | 8.950 | 0.000 | 0.000 |
| MARBLE FINISHERS | | BLD | | 25.520 | 0.000 | 1.5 | 1.5 | 2.0 | 5.900 | 5.110 | 0.000 | 0.470 |
| MARBLE MASON | | BLD | | 28.790 | 30.640 | 1.5 | 1.5 | 2.0 | 7.500 | 9.430 | 2.000 | 0.400 |
| MILLWRIGHT | | BLD | | 31.140 | 32.640 | 1.5 | 1.5 | 2.0 | 6.300 | 6.250 | 0.000 | 0.400 |
| MILLWRIGHT | | HWY | | 31.640 | 33.390 | 1.5 | 1.5 | 2.0 | 6.300 | 6.250 | 0.000 | 0.400 |
| OPERATING ENGINEER | | BLD | 1 | 33.650 | 36.650 | 1.5 | 1.5 | 2.0 | 8.400 | 16.50 | 0.000 | 1.000 |
| OPERATING ENGINEER | | BLD | 2 | 32.520 | 36.650 | 1.5 | 1.5 | 2.0 | 8.400 | 16.50 | 0.000 | 1.000 |
| OPERATING ENGINEER | | BLD | 3 | 28.040 | 36.650 | 1.5 | 1.5 | 2.0 | 8.400 | 16.50 | 0.000 | 1.000 |
| OPERATING ENGINEER | | BLD | 4 | 28.100 | 36.650 | 1.5 | 1.5 | 2.0 | 8.400 | 16.50 | 0.000 | 1.000 |
| OPERATING ENGINEER | | BLD | 5 | 27.770 | 36.650 | 1.5 | 1.5 | 2.0 | 8.400 | 16.50 | 0.000 | 1.000 |
| OPERATING ENGINEER | | BLD | 6 | 34.200 | 36.650 | 1.5 | 1.5 | 2.0 | 8.400 | 16.50 | 0.000 | 1.000 |
| OPERATING ENGINEER | | BLD | 7 | 34.500 | 36.650 | 1.5 | 1.5 | 2.0 | 8.400 | 16.50 | 0.000 | 1.000 |
| OPERATING ENGINEER | | BLD | 8 | 34.780 | 36.650 | 1.5 | 1.5 | 2.0 | 8.400 | 16.50 | 0.000 | 1.000 |
| OPERATING ENGINEER | | BLD | 9 | 35.650 | 36.650 | 1.5 | 1.5 | 2.0 | 8.400 | 16.50 | 0.000 | 1.000 |
| OPERATING ENGINEER | | HWY | 1 | 32.150 | 35.150 | 1.5 | 1.5 | 2.0 | 8.400 | 16.50 | 0.000 | 1.000 |
| OPERATING ENGINEER | | HWY | 2 | 31.020 | 35.150 | 1.5 | 1.5 | 2.0 | 8.400 | 16.50 | 0.000 | 1.000 |
| OPERATING ENGINEER | | HWY | 3 | 26.540 | 35.150 | 1.5 | 1.5 | 2.0 | 8.400 | 16.50 | 0.000 | 1.000 |
| OPERATING ENGINEER | | HWY | 4 | 26.600 | 35.150 | 1.5 | 1.5 | 2.0 | 8.400 | 16.50 | 0.000 | 1.000 |
| OPERATING ENGINEER | | HWY | 5 | 26.270 | 35.150 | 1.5 | 1.5 | 2.0 | 8.400 | 16.50 | 0.000 | 1.000 |
| OPERATING ENGINEER | | HWY | 6 | 32.700 | 35.150 | 1.5 | 1.5 | 2.0 | 8.400 | 16.50 | 0.000 | 1.000 |
| OPERATING ENGINEER | | HWY | 7 | 33.000 | 35.150 | 1.5 | 1.5 | 2.0 | 8.400 | 16.50 | 0.000 | 1.000 |
| OPERATING ENGINEER | | HWY | 8 | 33.280 | 35.150 | 1.5 | 1.5 | 2.0 | 8.400 | 16.50 | 0.000 | 1.000 |
| OPERATING ENGINEER | | HWY | 9 | 34.150 | 35.150 | 1.5 | 1.5 | 2.0 | 8.400 | 16.50 | 0.000 | 1.000 |
| PAINTER | | ALL | | 23.190 | 23.690 | 1.5 | 1.5 | 2.0 | 5.000 | 6.840 | 0.000 | 0.480 |
| PAINTER OVER 30FT | | ALL | | 26.290 | 26.790 | 1.5 | 1.5 | 2.0 | 5.000 | 6.840 | 0.000 | 0.480 |
| PAINTER PWR EQMT | | ALL | | 26.290 | 26.790 | 1.5 | 1.5 | 2.0 | 5.000 | 6.840 | 0.000 | 0.480 |
| PILEDRIVER | | BLD | | 31.140 | 32.640 | 1.5 | 1.5 | 2.0 | 6.300 | 6.250 | 0.000 | 0.400 |
| PILEDRIVER | | HWY | | 31.640 | 33.390 | 1.5 | 1.5 | 2.0 | 6.300 | 6.250 | 0.000 | 0.400 |
| PIPEFITTER | | BLD | | 33.250 | 36.580 | 1.5 | 1.5 | 2.0 | 5.950 | 6.350 | 0.000 | 0.900 |
| PLASTERER | | BLD | | 27.250 | 28.750 | 1.5 | 1.5 | 2.0 | 6.400 | 5.400 | 0.000 | 0.500 |
| PLUMBER | | BLD | | 33.250 | 36.580 | 1.5 | 1.5 | 2.0 | 5.950 | 6.350 | 0.000 | 0.900 |
| ROOFER | | BLD | | 23.000 | 24.000 | 1.5 | 1.5 | 2.0 | 8.300 | 3.800 | 0.000 | 0.000 |
| SHEETMETAL WORKER | | ALL | | 31.690 | 33.190 | 1.5 | 1.5 | 2.0 | 7.130 | 6.730 | 1.910 | 0.360 |
| SPRINKLER FITTER | | BLD | | 36.140 | 38.890 | 1.5 | 1.5 | 2.0 | 8.100 | 8.200 | 0.000 | 0.350 |
| TERRAZZO FINISHER | | BLD | | 31.240 | 0.000 | 1.5 | 1.5 | 2.0 | 5.900 | 2.730 | 0.000 | 0.130 |
| TERRAZZO MASON | | BLD | | 32.530 | 32.830 | 1.5 | 1.5 | 2.0 | 5.900 | 4.980 | 0.000 | 0.140 |

| | | | | | | | | | | | |
|--------------|-----|---|--------|-------|-----|-----|-----|-------|-------|-------|-------|
| TRUCK DRIVER | ALL | 1 | 30.460 | 0.000 | 1.5 | 1.5 | 2.0 | 10.05 | 4.775 | 0.000 | 0.250 |
| TRUCK DRIVER | ALL | 2 | 30.890 | 0.000 | 1.5 | 1.5 | 2.0 | 10.05 | 4.775 | 0.000 | 0.250 |
| TRUCK DRIVER | ALL | 3 | 31.120 | 0.000 | 1.5 | 1.5 | 2.0 | 10.05 | 4.775 | 0.000 | 0.250 |
| TRUCK DRIVER | ALL | 4 | 31.380 | 0.000 | 1.5 | 1.5 | 2.0 | 10.05 | 4.775 | 0.000 | 0.250 |
| TRUCK DRIVER | ALL | 5 | 32.200 | 0.000 | 1.5 | 1.5 | 2.0 | 10.05 | 4.775 | 0.000 | 0.250 |
| TRUCK DRIVER | O&C | 1 | 24.370 | 0.000 | 1.5 | 1.5 | 2.0 | 10.05 | 4.775 | 0.000 | 0.250 |
| TRUCK DRIVER | O&C | 2 | 24.710 | 0.000 | 1.5 | 1.5 | 2.0 | 10.05 | 4.775 | 0.000 | 0.250 |
| TRUCK DRIVER | O&C | 3 | 24.900 | 0.000 | 1.5 | 1.5 | 2.0 | 10.05 | 4.775 | 0.000 | 0.250 |
| TRUCK DRIVER | O&C | 4 | 25.100 | 0.000 | 1.5 | 1.5 | 2.0 | 10.05 | 4.775 | 0.000 | 0.250 |
| TRUCK DRIVER | O&C | 5 | 25.760 | 0.000 | 1.5 | 1.5 | 2.0 | 10.05 | 4.775 | 0.000 | 0.250 |

Legend :

RG (Region)

TYP (Trade Type - All,Highway,Building,Floating,Oil & Chip,Rivers)

C (Class)

Base (Base Wage Rate)

FRMAN (Foreman Rate)

M-F>8 (OT required for any hour greater than 8 worked each day, Mon through Fri.

OSA (Overtime (OT) is required for every hour worked on Saturday)

OSH (Overtime is required for every hour worked on Sunday and Holidays)

H/W (Health & Welfare Insurance)

Pensn (Pension)

Vac (Vacation)

Trng (Training)

Explanations

MARION COUNTY

The following list is considered as those days for which holiday rates of wages for work performed apply: New Years Day, Memorial Day, Fourth of July, Labor Day, Thanksgiving Day, Christmas Day and Veterans Day in some classifications/counties. Generally, any of these holidays which fall on a Sunday is celebrated on the following Monday. This then makes work performed on that Monday payable at the appropriate overtime rate for holiday pay. Common practice in a given local may alter certain days of celebration. If in doubt, please check with IDOL.

Oil and chip resealing (O&C) means the application of road oils and

liquid asphalt to coat an existing road surface, followed by application of aggregate chips or gravel to coated surface, and subsequent rolling of material to seal the surface.

EXPLANATION OF CLASSES

ASBESTOS - GENERAL - removal of asbestos material/mold and hazardous materials from any place in a building, including mechanical systems where those mechanical systems are to be removed. This includes the removal of asbestos materials/mold and hazardous materials from ductwork or pipes in a building when the building is to be demolished at the time or at some close future date.

ASBESTOS - MECHANICAL - removal of asbestos material from mechanical systems, such as pipes, ducts, and boilers, where the mechanical systems are to remain.

CERAMIC TILE FINISHER AND MARBLE FINISHER

The handling, at the building site, of all sand, cement, tile, marble or stone and all other materials that may be used and installed by [a] tile layer or marble mason. In addition, the grouting, cleaning, sealing, and mixing on the job site, and all other work as required in assisting the setter. The term "Ceramic" is used for naming the classification only and is in no way a limitation of the product handled. Ceramic takes into consideration most hard tiles.

ELECTRIC POWER LINEMAN

Construction, maintenance and dismantling of overhead and underground electric power lines, including high voltage pipe type cable work, and associated structures and equipment.

ELECTRIC POWER EQUIPMENT OPERATOR - CLASS 1

Operation of all crawler type equipment D-4 and larger from the ground to assist the Electric Power Linemen in performing their duties.

ELECTRIC POWER EQUIPMENT OPERATORS - CLASS 2

Operation of all other equipment from the ground to assist the Electric Power Linemen in performing their duties.

ELECTRIC POWER GROUNDMAN

Applies to workers who assist the Electric Power Lineman from the ground.

ELECTRONIC SYSTEMS TECHNICIAN

Installation, service and maintenance of low-voltage systems which utilizes the transmission and/or transference of voice, sound, vision, or digital for commercial, education, security and entertainment purposes for the following: TV monitoring and surveillance, background/foreground music, intercom and telephone interconnect, field programming, inventory control systems, microwave transmission, multi-media, multiplex, radio page, school, intercom and sound burglar alarms and low voltage master clock systems.

Excluded from this classification are energy management systems, life safety systems, supervisory controls and data acquisition systems not intrinsic with the above listed systems, fire alarm systems, nurse call systems and raceways exceeding fifteen feet in length.

OPERATING ENGINEER - BUILDING

GROUP I. Cranes, Dragline, Shovels, Skimmer Scoops, Clamshells or Derrick Boats, Pile Drivers, Crane-Type Backhoes, Asphalt Plant Operators, Concrete Plant Operators, Dredges, Asphalt Spreading Machines, All Locomotives, Cable Ways or Tower Machines, Hoists, Hydraulic Backhoes, Ditching Machines or Backfiller, Cherrypickers, Overhead Cranes, Roller - Steam or Gas, Concrete Pavers, Excavators, Concrete Breakers, Concrete Pumps, Bulk Cement Plants, Cement Pumps, Derrick-Type Drills, Boat Operators, Motor Graders or Pushcats, Scoops or Tournapulls, Bulldozers, Endloaders or Fork Lifts, Power Blade or Elevating Graders, Winch Cats, Boom or Winch Trucks or Boom Tractors, Pipe Wrapping or Painting Machines, Asphalt Plant Engineer, Journeyman Lubricating Engineer, Drills (other than Derrick Type), Mud Jacks, or Well Drilling Machines, Boring Machines or Track Jacks, Mixers, Conveyors (Two), Air Compressors (Two), Water Pumps regardless of size (Two), Welding Machines (Two), Siphons or Jets (Two), Winch Heads or Apparatuses (Two), Light Plants (Two), All Tractors regardless of size (straight tractor only), Fireman on Stationary Boilers, Automatic Elevators, Form Grading Machines, Finishing Machines, Power Sub-Grader or Ribbon Machines, Longitudinal Floats, Distributor Operators on Trucks, Winch Heads or Apparatuses (One), Mobil Track air and heaters (two to five), Heavy Equipment Greaser, Relief Operator, Assistant Master Mechanic and Heavy Duty Mechanic, self-propelled concrete saws of all types and sizes with their attachments, gob-hoppers, excavators all sizes, the repair and greasing of all diesel hammers, the operation and set-up of bidwells, water blasters of all sizes and their clutches, hydraulic jacks where used for hoisting, operation of log skidders, iceolators used on and off of pipeline, condor cranes, bow boats, survey boats, bobcats and all their attachments, skid steer loaders and all their attachments, creter cranes, batch plants, operator (all sizes), self propelled roto mills, operation of conveyor systems of any size and any configuration, operation, repair and service of all vibratory hammers, all power pacs and their controls regardless of location, curtains or brush burning machines, stump cutter machines, Nail launchers when mounted on a machine or self-propelled, operation of con-cover machines, and all Operators except those listed below).

GROUP II. Assistant Operators.

GROUP III. Air Compressors (One), Water Pumps, regardless of Size (One), Waterblasters (one), Welding Machine (One), Mixers (One Bag), Conveyor (One), Siphon or Jet (One), Light Plant (One), Heater (One), Immobile Track Air (One), and Self Propelled Walk-Behind Rollers.

GROUP IV. Asphalt Spreader Oilers, Fireman on Whirlies and Heavy Equipment Oilers, Truck Cranes, Dredges, Monigans, Large Cranes - (Over 65-ton rated capacity) Concrete Plant Oiler, Blacktop Plant Oiler, and Creter Crane Oiler (when required).

GROUP V. Oiler.

GROUP VI. Operators on equipment with Booms, including jibs, 100 feet and over, and less than 150 feet long.

GROUP VII. Operators on equipment with Booms, including jibs, 150 feet and over, and less than 200 feet long.

GROUP VIII. Operators on Equipment with Booms, including jibs, 200 feet and over; Tower Cranes; and Whirlie Cranes.

GROUP IX. Master Mechanic

OPERATING ENGINEERS - Highway

GROUP I. Cranes, Dragline, Shovels, Skimmer Scoops, Clamshells or Derrick Boats, Pile Drivers, Crane-Type Backhoes, Asphalt Plant Operators, Concrete Plant Operators, Dredges, Asphalt Spreading Machines, All Locomotives, Cable Ways or Tower Machines, Hoists, Hydraulic Backhoes, Ditching Machines or Backfiller, Cherrypickers, Overhead Cranes, Roller - Steam or Gas, Concrete Pavers, Excavators, Concrete Breakers, Concrete Pumps, Bulk Cement Plants, Cement Pumps, Derrick-Type Drills, Boat Operators, Motor Graders or Pushcats, Scoops or Tournapulls, Bulldozers, Endloaders or Fork Lifts, Power Blade or Elevating Graders, Winch Cats, Boom or Winch Trucks or Boom Tractors, Pipe Wrapping or Painting Machines, Asphalt Plant Engineer, Journeyman Lubricating Engineer, Drills (other than Derrick Type), Mud Jacks, Well Drilling Machines, Boring Machines, Track Jacks, Mixers, Conveyors (Two), Air Compressors (Two), Water Pumps regardless of size (Two), Welding Machines (Two), Siphons or Jets (Two), Winch Heads or Apparatuses (Two), Light Plants (Two), All Tractors regardless of size (straight tractor only), Fireman on Stationary Boilers, Automatic Elevators, Form Grading Machines, Finishing Machines, Power Sub-Grader or Ribbon Machines, Longitudinal Floats, Distributor Operators on Trucks, Winch Heads or Apparatuses (One), Mobil Track air and heaters (two to five), Heavy Equipment Greaser, Relief Operator, Assistant Master Mechanic and Heavy Duty Mechanic, self-propelled concrete saws of all types and sizes with their attachments, gob-hoppers, excavators all sizes, the repair and greasing of all diesel hammers, the operation and set-up of bidwells, water blasters of all sizes and their clutches, hydraulic jacks where used for hoisting, operation of log skidders, iceolators used on and off of pipeline, condor cranes, bow boats, survey boats, bobcats and all their attachments, skid steer loaders and all their attachments, creter cranes, batch plants, operator (all sizes), self propelled roto mills, operation of conveyor systems of any size and any configuration, operation, repair and service of all vibratory hammers, all power pacs and their controls regardless of location, curtains or brush burning machines, stump cutter machines, Nail launchers when mounted on a machine or self-propelled, operation of con-cover machines, and all Operators (except those listed below).

GROUP II. Assistant Operators.

GROUP III. Air Compressors (One), Water Pumps, regardless of Size (One), Waterblasters (one), Welding Machine (One), Mixers (One Bag), Conveyor (One), Siphon or Jet (One), Light Plant (One), Heater (One), Immobile Track Air (One), and Self Propelled Walk-Behind Rollers.

GROUP IV. Asphalt Spreader Oilers, Fireman on Whirlies and Heavy Equipment Oilers, Truck Cranes, Dredges, Monigans, Large Cranes - (Over 65-ton rated capacity) Concrete Plant Oiler, Blacktop Plant Oiler, and Creter Crane Oiler (when required).

GROUP V. Oiler.

GROUP VI. Operators on equipment with Booms, including jibs, 100 feet and over, and less than 150 feet long.

GROUP VII. Operators on equipment with Booms, including jibs, 150 feet and over, and less than 200 feet long.

GROUP VIII. Operators on Equipment with Booms, including jibs, 200

feet and over; Tower Cranes; and Whirlie Cranes.

GROUP IX. Mechanic

TRUCK DRIVER - BUILDING, HEAVY AND HIGHWAY CONSTRUCTION

Class 1. Drivers on 2 axle trucks hauling less than 9 ton. Air compressor and welding machines and brooms, including those pulled by separate units, truck driver helpers, warehouse employees, mechanic helpers, greasers and tiremen, pickup trucks when hauling materials, tools, or workers to and from and on-the-job site, and fork lifts up to 6,000 lb. capacity.

Class 2. Two or three axle trucks hauling more than 9 ton but hauling less than 16 ton. A-frame winch trucks, hydrolift trucks, vactor trucks or similar equipment when used for transportation purposes. Fork lifts over 6,000 lb. capacity, winch trucks, four axle combination units, and ticket writers.

Class 3. Two, three or four axle trucks hauling 16 ton or more. Drivers on water pulls, articulated dump trucks, mechanics and working forepersons, and dispatchers. Five axle or more combination units.

Class 4. Low Boy and Oil Distributors.

Class 5. Drivers who require special protective clothing while employed on hazardous waste work.

TRUCK DRIVER - OIL AND CHIP RESEALING ONLY.

This shall encompass laborers, workers and mechanics who drive contractor or subcontractor owned, leased, or hired pickup, dump, service, or oil distributor trucks. The work includes transporting materials and equipment (including but not limited to, oils, aggregate supplies, parts, machinery and tools) to or from the job site; distributing oil or liquid asphalt and aggregate; stock piling material when in connection with the actual oil and chip contract. The Truck Driver (Oil & Chip Resealing) wage classification does not include supplier delivered materials.

TERRAZZO FINISHER

The handling of all materials used for Mosaic and Terrazzo work including preparing, mixing by hand, by mixing machine or transporting of pre-mixed materials and distributing with shovel, rake, hoe, or pail, all kinds of concrete foundations necessary for Mosaic and Terrazzo work, all cement terrazzo, magnesite terrazzo, Do-O-Tex terrazzo, epoxy matrix ter-razzo, exposed aggregate, rustic or rough washed for exterior or interior of buildings placed either by machine or by hand, and any other kind of mixture of plastics composed of chips or granules when mixed with cement, rubber, neoprene, vinyl, magnesium chloride or any other resinous or chemical substances used for seamless flooring systems, and all other building materials, all similar materials and all precast terrazzo work on jobs, all scratch coat used for Mosaic and Terrazzo work and sub-bed, tar paper and wire mesh (2x2 etc.) or lath. The rubbing, grinding, cleaning and finishing of same either by hand or by machine or by terrazzo resurfacing equipment on new or existing floors. When necessary finishers shall be allowed to assist the mechanics to spread sand bed, lay tarpaper and wire mesh (2x2 etc.) or lath. The finishing of cement floors where additional aggregate of stone is added by spreading or sprinkling on top of the finished base, and troweled or

rolled into the finish and then the surface is ground by grinding machines.

Other Classifications of Work:

For definitions of classifications not otherwise set out, the Department generally has on file such definitions which are available. If a task to be performed is not subject to one of the classifications of pay set out, the Department will upon being contacted state which neighboring county has such a classification and provide such rate, such rate being deemed to exist by reference in this document. If no neighboring county rate applies to the task, the Department shall undertake a special determination, such special determination being then deemed to have existed under this determination. If a project requires these, or any classification not listed, please contact IDOL at 217-782-1710 for wage rates or clarifications.

LANDSCAPING

Landscaping work falls under the existing classifications for laborer, operating engineer and truck driver. The work performed by landscape plantsman and landscape laborer is covered by the existing classification of laborer. The work performed by landscape operators (regardless of equipment used or its size) is covered by the classifications of operating engineer. The work performed by landscape truck drivers (regardless of size of truck driven) is covered by the classifications of truck driver.

Monroe County Prevailing Wage for May 2012

(See explanation of column headings at bottom of wages)

| Trade Name | RG | TYP | C | Base | FRMAN | *M-F>8 | OSA | OSH | H/W | Pensn | Vac | Trng |
|----------------------|----|-----|---|--------|--------|--------|-----|-----|-------|-------|-------|-------|
| ===== | == | === | = | ===== | ===== | ===== | === | === | ===== | ===== | ===== | ===== |
| ASBESTOS ABT-GEN | | ALL | | 26.350 | 26.850 | 1.5 | 1.5 | 2.0 | 5.550 | 12.80 | 0.000 | 0.800 |
| ASBESTOS ABT-MEC | | BLD | | 29.160 | 30.160 | 1.5 | 1.5 | 2.0 | 6.700 | 2.750 | 0.000 | 0.000 |
| BOILERMAKER | | BLD | | 31.500 | 34.000 | 1.5 | 1.5 | 2.0 | 7.070 | 18.73 | 1.000 | 0.350 |
| BRICK MASON | | BLD | | 28.790 | 30.640 | 1.5 | 1.5 | 2.0 | 7.500 | 9.430 | 2.000 | 0.400 |
| CARPENTER | | ALL | | 33.880 | 35.380 | 1.5 | 1.5 | 2.0 | 6.300 | 6.250 | 0.000 | 0.400 |
| CEMENT MASON | | ALL | | 31.000 | 32.000 | 1.5 | 1.5 | 2.0 | 8.750 | 11.00 | 0.000 | 0.200 |
| CERAMIC TILE FNSHER | | BLD | | 25.520 | 0.000 | 1.5 | 1.5 | 2.0 | 5.900 | 5.110 | 0.000 | 0.470 |
| ELECTRIC PWR EQMT OP | | ALL | | 34.800 | 0.000 | 1.5 | 2.0 | 2.0 | 5.850 | 9.750 | 0.000 | 0.260 |
| ELECTRIC PWR GRNDMAN | | ALL | | 25.980 | 0.000 | 1.5 | 2.0 | 2.0 | 4.370 | 7.280 | 0.000 | 0.190 |
| ELECTRIC PWR LINEMAN | | ALL | | 40.020 | 41.950 | 1.5 | 2.0 | 2.0 | 6.720 | 11.21 | 0.000 | 0.300 |
| ELECTRIC PWR TRK DRV | | ALL | | 28.410 | 0.000 | 1.5 | 2.0 | 2.0 | 4.780 | 7.950 | 0.000 | 0.210 |
| ELECTRICIAN | | ALL | | 36.510 | 38.700 | 1.5 | 1.5 | 2.0 | 7.210 | 7.490 | 0.000 | 0.640 |
| ELECTRONIC SYS TECH | | BLD | | 29.920 | 31.670 | 1.5 | 1.5 | 2.0 | 3.200 | 7.400 | 0.000 | 0.250 |
| ELEVATOR CONSTRUCTOR | | BLD | | 43.345 | 48.760 | 2.0 | 2.0 | 2.0 | 11.03 | 11.96 | 2.600 | 0.000 |
| FLOOR LAYER | | BLD | | 29.080 | 29.830 | 1.5 | 1.5 | 2.0 | 6.300 | 6.250 | 0.000 | 0.400 |
| GLAZIER | | BLD | | 32.780 | 0.000 | 2.0 | 2.0 | 2.0 | 9.020 | 10.80 | 2.630 | 0.310 |
| HT/FROST INSULATOR | | BLD | | 36.760 | 37.760 | 1.5 | 1.5 | 2.0 | 7.550 | 10.76 | 0.000 | 0.500 |
| IRON WORKER | | ALL | | 31.000 | 33.000 | 1.5 | 1.5 | 2.0 | 7.110 | 12.35 | 0.000 | 0.420 |
| LABORER | | ALL | | 25.850 | 26.350 | 1.5 | 1.5 | 2.0 | 5.550 | 12.80 | 0.000 | 0.800 |
| MACHINIST | | BLD | | 43.160 | 45.160 | 1.5 | 1.5 | 2.0 | 7.980 | 8.950 | 0.000 | 0.000 |
| MARBLE FINISHERS | | BLD | | 25.520 | 0.000 | 1.5 | 1.5 | 2.0 | 5.900 | 5.110 | 0.000 | 0.470 |
| MARBLE MASON | | BLD | | 28.790 | 30.640 | 1.5 | 1.5 | 2.0 | 7.500 | 9.430 | 2.000 | 0.400 |
| MILLWRIGHT | | ALL | | 33.880 | 35.380 | 1.5 | 1.5 | 2.0 | 6.300 | 6.250 | 0.000 | 0.400 |
| OPERATING ENGINEER | | BLD | 1 | 33.650 | 36.650 | 1.5 | 1.5 | 2.0 | 8.400 | 16.50 | 0.000 | 1.000 |
| OPERATING ENGINEER | | BLD | 2 | 32.520 | 36.650 | 1.5 | 1.5 | 2.0 | 8.400 | 16.50 | 0.000 | 1.000 |
| OPERATING ENGINEER | | BLD | 3 | 28.040 | 36.650 | 1.5 | 1.5 | 2.0 | 8.400 | 16.50 | 0.000 | 1.000 |
| OPERATING ENGINEER | | BLD | 4 | 28.100 | 36.650 | 1.5 | 1.5 | 2.0 | 8.400 | 16.50 | 0.000 | 1.000 |
| OPERATING ENGINEER | | BLD | 5 | 27.770 | 36.650 | 1.5 | 1.5 | 2.0 | 8.400 | 16.50 | 0.000 | 1.000 |
| OPERATING ENGINEER | | BLD | 6 | 34.200 | 36.650 | 1.5 | 1.5 | 2.0 | 8.400 | 16.50 | 0.000 | 1.000 |
| OPERATING ENGINEER | | BLD | 7 | 34.500 | 36.650 | 1.5 | 1.5 | 2.0 | 8.400 | 16.50 | 0.000 | 1.000 |
| OPERATING ENGINEER | | BLD | 8 | 34.780 | 36.650 | 1.5 | 1.5 | 2.0 | 8.400 | 16.50 | 0.000 | 1.000 |
| OPERATING ENGINEER | | BLD | 9 | 35.650 | 36.650 | 1.5 | 1.5 | 2.0 | 8.400 | 16.50 | 0.000 | 1.000 |
| OPERATING ENGINEER | | HWY | 1 | 32.150 | 35.150 | 1.5 | 1.5 | 2.0 | 8.400 | 16.50 | 0.000 | 1.000 |
| OPERATING ENGINEER | | HWY | 2 | 31.020 | 35.150 | 1.5 | 1.5 | 2.0 | 8.400 | 16.50 | 0.000 | 1.000 |
| OPERATING ENGINEER | | HWY | 3 | 26.540 | 35.150 | 1.5 | 1.5 | 2.0 | 8.400 | 16.50 | 0.000 | 1.000 |
| OPERATING ENGINEER | | HWY | 4 | 26.600 | 35.150 | 1.5 | 1.5 | 2.0 | 8.400 | 16.50 | 0.000 | 1.000 |
| OPERATING ENGINEER | | HWY | 5 | 26.270 | 35.150 | 1.5 | 1.5 | 2.0 | 8.400 | 16.50 | 0.000 | 1.000 |
| OPERATING ENGINEER | | HWY | 6 | 32.700 | 35.150 | 1.5 | 1.5 | 2.0 | 8.400 | 16.50 | 0.000 | 1.000 |
| OPERATING ENGINEER | | HWY | 7 | 33.000 | 35.150 | 1.5 | 1.5 | 2.0 | 8.400 | 16.50 | 0.000 | 1.000 |
| OPERATING ENGINEER | | HWY | 8 | 33.280 | 35.150 | 1.5 | 1.5 | 2.0 | 8.400 | 16.50 | 0.000 | 1.000 |
| OPERATING ENGINEER | | HWY | 9 | 34.150 | 35.150 | 1.5 | 1.5 | 2.0 | 8.400 | 16.50 | 0.000 | 1.000 |
| PAINTER | | BLD | | 29.250 | 30.750 | 1.5 | 1.5 | 2.0 | 5.000 | 7.920 | 0.000 | 0.600 |
| PAINTER | | HWY | | 30.450 | 31.950 | 1.5 | 1.5 | 2.0 | 5.000 | 7.920 | 0.000 | 0.600 |
| PAINTER OVER 30FT | | BLD | | 30.250 | 31.750 | 1.5 | 1.5 | 2.0 | 5.000 | 7.920 | 0.000 | 0.600 |
| PAINTER PWR EQMT | | BLD | | 30.250 | 31.750 | 1.5 | 1.5 | 2.0 | 5.000 | 7.920 | 0.000 | 0.600 |
| PAINTER PWR EQMT | | HWY | | 31.450 | 32.950 | 1.5 | 1.5 | 2.0 | 5.000 | 7.920 | 0.000 | 0.600 |
| PILEDRIIVER | | ALL | | 33.880 | 35.380 | 1.5 | 1.5 | 2.0 | 6.300 | 6.250 | 0.000 | 0.400 |
| PIPEFITTER | | BLD | | 36.000 | 38.000 | 1.5 | 1.5 | 2.0 | 6.690 | 8.000 | 0.000 | 0.750 |
| PLASTERER | | BLD | | 30.250 | 31.250 | 1.5 | 1.5 | 2.0 | 8.750 | 8.300 | 0.000 | 0.050 |
| PLUMBER | | BLD | | 35.150 | 37.650 | 1.5 | 1.5 | 2.0 | 6.000 | 6.600 | 0.000 | 0.400 |
| ROOFER | | BLD | | 28.650 | 30.650 | 1.5 | 1.5 | 2.0 | 8.150 | 6.650 | 0.000 | 0.200 |
| SHEETMETAL WORKER | | ALL | | 31.690 | 33.190 | 1.5 | 1.5 | 2.0 | 7.130 | 6.730 | 1.910 | 0.360 |
| SPRINKLER FITTER | | BLD | | 37.830 | 40.830 | 2.0 | 2.0 | 2.0 | 8.550 | 10.35 | 0.000 | 0.850 |
| TERRAZZO FINISHER | | BLD | | 31.240 | 0.000 | 1.5 | 1.5 | 2.0 | 5.900 | 2.730 | 0.000 | 0.130 |
| TERRAZZO MASON | | BLD | | 32.530 | 32.830 | 1.5 | 1.5 | 2.0 | 5.900 | 4.980 | 0.000 | 0.140 |
| TRUCK DRIVER | | ALL | 1 | 30.460 | 0.000 | 1.5 | 1.5 | 2.0 | 10.05 | 4.775 | 0.000 | 0.250 |
| TRUCK DRIVER | | ALL | 2 | 30.890 | 0.000 | 1.5 | 1.5 | 2.0 | 10.05 | 4.775 | 0.000 | 0.250 |

| | | | | | | | | | | | |
|--------------|-----|---|--------|-------|-----|-----|-----|-------|-------|-------|-------|
| TRUCK DRIVER | ALL | 3 | 31.120 | 0.000 | 1.5 | 1.5 | 2.0 | 10.05 | 4.775 | 0.000 | 0.250 |
| TRUCK DRIVER | ALL | 4 | 31.380 | 0.000 | 1.5 | 1.5 | 2.0 | 10.05 | 4.775 | 0.000 | 0.250 |
| TRUCK DRIVER | ALL | 5 | 32.200 | 0.000 | 1.5 | 1.5 | 2.0 | 10.05 | 4.775 | 0.000 | 0.250 |
| TRUCK DRIVER | O&C | 1 | 24.370 | 0.000 | 1.5 | 1.5 | 2.0 | 10.05 | 4.775 | 0.000 | 0.250 |
| TRUCK DRIVER | O&C | 2 | 24.710 | 0.000 | 1.5 | 1.5 | 2.0 | 10.05 | 4.775 | 0.000 | 0.250 |
| TRUCK DRIVER | O&C | 3 | 24.900 | 0.000 | 1.5 | 1.5 | 2.0 | 10.05 | 4.775 | 0.000 | 0.250 |
| TRUCK DRIVER | O&C | 4 | 25.100 | 0.000 | 1.5 | 1.5 | 2.0 | 10.05 | 4.775 | 0.000 | 0.250 |
| TRUCK DRIVER | O&C | 5 | 25.760 | 0.000 | 1.5 | 1.5 | 2.0 | 10.05 | 4.775 | 0.000 | 0.250 |

Legend:

RG (Region)

TYP (Trade Type - All,Highway,Building,Floating,Oil & Chip,Rivers)

C (Class)

Base (Base Wage Rate)

FRMAN (Foreman Rate)

M-F>8 (OT required for any hour greater than 8 worked each day, Mon through Fri.

OSA (Overtime (OT) is required for every hour worked on Saturday)

OSH (Overtime is required for every hour worked on Sunday and Holidays)

H/W (Health & Welfare Insurance)

Pensn (Pension)

Vac (Vacation)

Trng (Training)

Explanations

MONROE COUNTY

The following list is considered as those days for which holiday rates of wages for work performed apply: New Years Day, Memorial Day, Fourth of July, Labor Day, Thanksgiving Day, Christmas Day and Veterans Day in some classifications/counties. Generally, any of these holidays which fall on a Sunday is celebrated on the following Monday. This then makes work performed on that Monday payable at the appropriate overtime rate for holiday pay. Common practice in a given local may alter certain days of celebration. If in doubt, please check with IDOL.

Oil and chip resealing (O&C) means the application of road oils and

liquid asphalt to coat an existing road surface, followed by application of aggregate chips or gravel to coated surface, and subsequent rolling of material to seal the surface.

EXPLANATION OF CLASSES

ASBESTOS - GENERAL - removal of asbestos material/mold and hazardous materials from any place in a building, including mechanical systems where those mechanical systems are to be removed. This includes the removal of asbestos materials/mold and hazardous materials from ductwork or pipes in a building when the building is to be demolished at the time or at some close future date.

ASBESTOS - MECHANICAL - removal of asbestos material from mechanical systems, such as pipes, ducts, and boilers, where the mechanical systems are to remain.

CERAMIC TILE FINISHER AND MARBLE FINISHER

The handling, at the building site, of all sand, cement, tile, marble or stone and all other materials that may be used and installed by [a] tile layer or marble mason. In addition, the grouting, cleaning, sealing, and mixing on the job site, and all other work as required in assisting the setter. The term "Ceramic" is used for naming the classification only and is in no way a limitation of the product handled. Ceramic takes into consideration most hard tiles.

ELECTRONIC SYSTEMS TECHNICIAN

Installation, service and maintenance of low-voltage systems which utilizes the transmission and/or transference of voice, sound, vision, or digital for commercial, education, security and entertainment purposes for the following: TV monitoring and surveillance, background/foreground music, intercom and telephone interconnect, field programming, inventory control systems, microwave transmission, multi-media, multiplex, radio page, school, intercom and sound burglar alarms and low voltage master clock systems.

Excluded from this classification are energy management systems, life safety systems, supervisory controls and data acquisition systems not intrinsic with the above listed systems, fire alarm systems, nurse call systems and raceways exceeding fifteen feet in length.

OPERATING ENGINEER - BUILDING

GROUP I. Cranes, Dragline, Shovels, Skimmer Scoops, Clamshells or Derrick Boats, Pile Drivers, Crane-Type Backhoes, Asphalt Plant Operators, Concrete Plant Operators, Dredges, Asphalt Spreading Machines, All Locomotives, Cable Ways or Tower Machines, Hoists, Hydraulic Backhoes, Ditching Machines or Backfiller, Cherrypickers, Overhead Cranes, Roller - Steam or Gas, Concrete Pavers, Excavators, Concrete Breakers, Concrete Pumps, Bulk Cement Plants, Cement Pumps, Derrick-Type Drills, Boat Operators, Motor Graders or Pushcats, Scoops or Tournapulls, Bulldozers, Endloaders or Fork Lifts, Power Blade or Elevating Graders, Winch Cats, Boom or Winch Trucks or Boom Tractors, Pipe Wrapping or Painting Machines, Asphalt Plant Engineer, Journeyman Lubricating Engineer, Drills (other than Derrick Type), Mud Jacks, or Well Drilling Machines, Boring Machines or Track Jacks, Mixers, Conveyors (Two), Air Compressors (Two), Water Pumps regardless of size (Two), Welding Machines (Two), Siphons or Jets (Two), Winch Heads or Apparatuses (Two), Light Plants (Two), All Tractors regardless of size (straight tractor only), Fireman on Stationary Boilers, Automatic Elevators, Form Grading Machines, Finishing Machines, Power Sub-Grader

or Ribbon Machines, Longitudinal Floats, Distributor Operators on Trucks, Winch Heads or Apparatuses (One), Mobil Track air and heaters (two to five), Heavy Equipment Greaser, Relief Operator, Assistant Master Mechanic and Heavy Duty Mechanic, self-propelled concrete saws of all types and sizes with their attachments, gob-hoppers, excavators all sizes, the repair and greasing of all diesel hammers, the operation and set-up of bidwells, water blasters of all sizes and their clutches, hydraulic jacks where used for hoisting, operation of log skidders, iceolators used on and off of pipeline, condor cranes, bow boats, survey boats, bobcats and all their attachments, skid steer loaders and all their attachments, creter cranes, batch plants, operator (all sizes), self propelled roto mills, operation of conveyor systems of any size and any configuration, operation, repair and service of all vibratory hammers, all power pacs and their controls regardless of location, curtains or brush burning machines, stump cutter machines, Nail launchers when mounted on a machine or self-propelled, operation of con-cover machines, and all Operators except those listed below).

GROUP II. Assistant Operators.

GROUP III. Air Compressors (One), Water Pumps, regardless of Size (One), Waterblasters (one), Welding Machine (One), Mixers (One Bag), Conveyor (One), Siphon or Jet (One), Light Plant (One), Heater (One), Immobile Track Air (One), and Self Propelled Walk-Behind Rollers.

GROUP IV. Asphalt Spreader Oilers, Fireman on Whirlies and Heavy Equipment Oilers, Truck Cranes, Dredges, Monigans, Large Cranes - (Over 65-ton rated capacity) Concrete Plant Oiler, Blacktop Plant Oiler, and Creter Crane Oiler (when required).

GROUP V. Oiler.

GROUP VI. Operators on equipment with Booms, including jibs, 100 feet and over, and less than 150 feet long.

GROUP VII. Operators on equipment with Booms, including jibs, 150 feet and over, and less than 200 feet long.

GROUP VIII. Operators on Equipment with Booms, including jibs, 200 feet and over; Tower Cranes; and Whirlie Cranes.

GROUP IX. Master Mechanic

OPERATING ENGINEERS - Highway

GROUP I. Cranes, Dragline, Shovels, Skimmer Scoops, Clamshells or Derrick Boats, Pile Drivers, Crane-Type Backhoes, Asphalt Plant Operators, Concrete Plant Operators, Dredges, Asphalt Spreading Machines, All Locomotives, Cable Ways or Tower Machines, Hoists, Hydraulic Backhoes, Ditching Machines or Backfiller, Cherrypickers, Overhead Cranes, Roller - Steam or Gas, Concrete Pavers, Excavators, Concrete Breakers, Concrete Pumps, Bulk Cement Plants, Cement Pumps, Derrick-Type Drills, Boat Operators, Motor Graders or Pushcats, Scoops or Tournapulls, Bulldozers, Endloaders or Fork Lifts, Power Blade or Elevating Graders, Winch Cats, Boom or Winch Trucks or Boom Tractors, Pipe Wrapping or Painting Machines, Asphalt Plant Engineer, Journeyman Lubricating Engineer, Drills (other than Derrick Type), Mud Jacks, Well Drilling Machines, Boring Machines, Track Jacks, Mixers, Conveyors (Two), Air Compressors (Two), Water Pumps regardless of size (Two), Welding Machines (Two), Siphons or Jets (Two), Winch Heads or Apparatuses (Two), Light Plants (Two), All Tractors regardless of size (straight tractor only), Fireman on Stationary Boilers, Automatic

Elevators, Form Grading Machines, Finishing Machines, Power Sub-Grader or Ribbon Machines, Longitudinal Floats, Distributor Operators on Trucks, Winch Heads or Apparatuses (One), Mobil Track air and heaters (two to five), Heavy Equipment Greaser, Relief Operator, Assistant Master Mechanic and Heavy Duty Mechanic, self-propelled concrete saws of all types and sizes with their attachments, gob-hoppers, excavators all sizes, the repair and greasing of all diesel hammers, the operation and set-up of bidwells, water blasters of all sizes and their clutches, hydraulic jacks where used for hoisting, operation of log skidders, iceolators used on and off of pipeline, condor cranes, bow boats, survey boats, bobcats and all their attachments, skid steer loaders and all their attachments, creter cranes, batch plants, operator (all sizes), self propelled roto mills, operation of conveyor systems of any size and any configuration, operation, repair and service of all vibratory hammers, all power pacs and their controls regardless of location, curtains or brush burning machines, stump cutter machines, Nail launchers when mounted on a machine or self-propelled, operation of con-cover machines, and all Operators (except those listed below).

GROUP II. Assistant Operators.

GROUP III. Air Compressors (One), Water Pumps, regardless of Size (One), Waterblasters (one), Welding Machine (One), Mixers (One Bag), Conveyor (One), Siphon or Jet (One), Light Plant (One), Heater (One), Immobile Track Air (One), and Self Propelled Walk-Behind Rollers.

GROUP IV. Asphalt Spreader Oilers, Fireman on Whirlies and Heavy Equipment Oilers, Truck Cranes, Dredges, Monigans, Large Cranes - (Over 65-ton rated capacity) Concrete Plant Oiler, Blacktop Plant Oiler, and Creter Crane Oiler (when required).

GROUP V. Oiler.

GROUP VI. Operators on equipment with Booms, including jibs, 100 feet and over, and less than 150 feet long.

GROUP VII. Operators on equipment with Booms, including jibs, 150 feet and over, and less than 200 feet long.

GROUP VIII. Operators on Equipment with Booms, including jibs, 200 feet and over; Tower Cranes; and Whirlie Cranes.

GROUP IX. Mechanic

TRUCK DRIVER - BUILDING, HEAVY AND HIGHWAY CONSTRUCTION

Class 1. Drivers on 2 axle trucks hauling less than 9 ton. Air compressor and welding machines and brooms, including those pulled by separate units, truck driver helpers, warehouse employees, mechanic helpers, greasers and tiremen, pickup trucks when hauling materials, tools, or workers to and from and on-the-job site, and fork lifts up to 6,000 lb. capacity.

Class 2. Two or three axle trucks hauling more than 9 ton but hauling less than 16 ton. A-frame winch trucks, hydrolift trucks, vactor trucks or similar equipment when used for transportation purposes. Fork lifts over 6,000 lb. capacity, winch trucks, four axle combination units, and ticket writers.

Class 3. Two, three or four axle trucks hauling 16 ton or more. Drivers on water pulls, articulated dump trucks, mechanics and working

forepersons, and dispatchers. Five axle or more combination units.

Class 4. Low Boy and Oil Distributors.

Class 5. Drivers who require special protective clothing while employed on hazardous waste work.

TRUCK DRIVER - OIL AND CHIP RESEALING ONLY.

This shall encompass laborers, workers and mechanics who drive contractor or subcontractor owned, leased, or hired pickup, dump, service, or oil distributor trucks. The work includes transporting materials and equipment (including but not limited to, oils, aggregate supplies, parts, machinery and tools) to or from the job site; distributing oil or liquid asphalt and aggregate; stock piling material when in connection with the actual oil and chip contract. The Truck Driver (Oil & Chip Resealing) wage classification does not include supplier delivered materials.

TERRAZZO FINISHER

The handling of all materials used for Mosaic and Terrazzo work including preparing, mixing by hand, by mixing machine or transporting of pre-mixed materials and distributing with shovel, rake, hoe, or pail, all kinds of concrete foundations necessary for Mosaic and Terrazzo work, all cement terrazzo, magnesite terrazzo, Do-O-Tex terrazzo, epoxy matrix terrazzo, exposed aggregate, rustic or rough washed for exterior or interior of buildings placed either by machine or by hand, and any other kind of mixture of plastics composed of chips or granules when mixed with cement, rubber, neoprene, vinyl, magnesium chloride or any other resinous or chemical substances used for seamless flooring systems, and all other building materials, all similar materials and all precast terrazzo work on jobs, all scratch coat used for Mosaic and Terrazzo work and sub-bed, tar paper and wire mesh (2x2 etc.) or lath. The rubbing, grinding, cleaning and finishing of same either by hand or by machine or by terrazzo resurfacing equipment on new or existing floors. When necessary finishers shall be allowed to assist the mechanics to spread sand bed, lay tarpaper and wire mesh (2x2 etc.) or lath. The finishing of cement floors where additional aggregate of stone is added by spreading or sprinkling on top of the finished base, and troweled or rolled into the finish and then the surface is ground by grinding machines.

Other Classifications of Work:

For definitions of classifications not otherwise set out, the Department generally has on file such definitions which are available. If a task to be performed is not subject to one of the classifications of pay set out, the Department will upon being contacted state which neighboring county has such a classification and provide such rate, such rate being deemed to exist by reference in this document. If no neighboring county rate applies to the task, the Department shall undertake a special determination, such special determination being then deemed to have existed under this determination. If a project requires these, or any classification not listed, please contact IDOL at 217-782-1710 for wage rates or clarifications.

LANDSCAPING

Landscaping work falls under the existing classifications for laborer, operating engineer and truck driver. The work performed by landscape plantsman and landscape laborer is covered by the existing classification of laborer. The work performed by landscape operators (regardless of equipment used or its size) is covered by the classifications of operating engineer. The work performed by landscape truck drivers (regardless of size of truck driven) is covered by the classifications of truck driver.

Randolph County Prevailing Wage for May 2012

(See explanation of column headings at bottom of wages)

| Trade Name | RG | TYP | C | Base | FRMAN | *M-F>8 | OSA | OSH | H/W | Pensn | Vac | Trng |
|----------------------|----|-----|---|--------|--------|--------|-----|-----|-------|-------|-------|-------|
| ===== | == | === | = | ===== | ===== | ===== | === | === | ===== | ===== | ===== | ===== |
| ASBESTOS ABT-GEN | | ALL | | 26.810 | 27.310 | 1.5 | 1.5 | 2.0 | 5.550 | 12.34 | 0.000 | 0.800 |
| ASBESTOS ABT-MEC | | BLD | | 29.160 | 30.160 | 1.5 | 1.5 | 2.0 | 6.700 | 2.750 | 0.000 | 0.000 |
| BOILERMAKER | | BLD | | 31.500 | 34.000 | 1.5 | 1.5 | 2.0 | 7.070 | 18.73 | 1.000 | 0.350 |
| BRICK MASON | | BLD | | 28.620 | 30.120 | 1.5 | 1.5 | 2.0 | 8.200 | 7.030 | 0.000 | 0.430 |
| CARPENTER | | ALL | | 33.880 | 35.380 | 1.5 | 1.5 | 2.0 | 6.300 | 6.250 | 0.000 | 0.400 |
| CEMENT MASON | | BLD | | 28.200 | 29.700 | 1.5 | 1.5 | 2.0 | 6.600 | 5.400 | 0.000 | 0.500 |
| CEMENT MASON | | HWY | | 27.290 | 28.290 | 1.5 | 1.5 | 2.0 | 6.600 | 5.160 | 0.000 | 0.400 |
| CERAMIC TILE FNSHER | | BLD | | 27.120 | 0.000 | 1.5 | 1.5 | 2.0 | 8.200 | 7.030 | 0.000 | 0.430 |
| ELECTRIC PWR EQMT OP | | ALL | | 34.800 | 0.000 | 1.5 | 2.0 | 2.0 | 5.850 | 9.750 | 0.000 | 0.260 |
| ELECTRIC PWR GRNDMAN | | ALL | | 25.980 | 0.000 | 1.5 | 2.0 | 2.0 | 4.370 | 7.280 | 0.000 | 0.190 |
| ELECTRIC PWR LINEMAN | | ALL | | 40.020 | 41.950 | 1.5 | 2.0 | 2.0 | 6.720 | 11.21 | 0.000 | 0.300 |
| ELECTRIC PWR TRK DRV | | ALL | | 28.410 | 0.000 | 1.5 | 2.0 | 2.0 | 4.780 | 7.950 | 0.000 | 0.210 |
| ELECTRICIAN | NW | ALL | | 36.510 | 38.700 | 1.5 | 1.5 | 2.0 | 7.210 | 7.490 | 0.000 | 0.640 |
| ELECTRICIAN | SE | ALL | | 37.930 | 40.180 | 1.5 | 1.5 | 2.0 | 5.350 | 9.110 | 0.000 | 0.760 |
| ELECTRONIC SYS TECH | NW | BLD | | 29.920 | 31.670 | 1.5 | 1.5 | 2.0 | 3.200 | 7.400 | 0.000 | 0.250 |
| ELECTRONIC SYS TECH | SE | BLD | | 31.870 | 33.620 | 1.5 | 1.5 | 2.0 | 5.350 | 4.150 | 0.000 | 0.400 |
| ELEVATOR CONSTRUCTOR | | BLD | | 43.345 | 48.760 | 2.0 | 2.0 | 2.0 | 11.03 | 11.96 | 2.600 | 0.000 |
| FLOOR LAYER | | BLD | | 29.080 | 29.830 | 1.5 | 1.5 | 2.0 | 6.300 | 6.250 | 0.000 | 0.400 |
| GLAZIER | | BLD | | 32.780 | 0.000 | 2.0 | 2.0 | 2.0 | 9.020 | 10.80 | 2.630 | 0.310 |
| HT/FROST INSULATOR | | BLD | | 36.760 | 37.760 | 1.5 | 1.5 | 2.0 | 7.550 | 10.76 | 0.000 | 0.500 |
| IRON WORKER | | ALL | | 31.000 | 33.000 | 1.5 | 1.5 | 2.0 | 7.110 | 12.35 | 0.000 | 0.420 |
| LABORER | | ALL | | 26.310 | 26.810 | 1.5 | 1.5 | 2.0 | 5.550 | 12.34 | 0.000 | 0.800 |
| MACHINIST | | BLD | | 43.160 | 45.160 | 1.5 | 1.5 | 2.0 | 7.980 | 8.950 | 0.000 | 0.000 |
| MARBLE FINISHERS | | BLD | | 27.120 | 0.000 | 1.5 | 1.5 | 2.0 | 8.200 | 7.030 | 0.000 | 0.430 |
| MARBLE MASON | | BLD | | 28.620 | 30.120 | 1.5 | 1.5 | 2.0 | 8.200 | 7.030 | 0.000 | 0.430 |
| MILLWRIGHT | | ALL | | 33.880 | 35.380 | 1.5 | 1.5 | 2.0 | 6.300 | 6.250 | 0.000 | 0.400 |
| OPERATING ENGINEER | | BLD | 1 | 33.650 | 36.650 | 1.5 | 1.5 | 2.0 | 8.400 | 16.50 | 0.000 | 1.000 |
| OPERATING ENGINEER | | BLD | 2 | 32.520 | 36.650 | 1.5 | 1.5 | 2.0 | 8.400 | 16.50 | 0.000 | 1.000 |
| OPERATING ENGINEER | | BLD | 3 | 28.040 | 36.650 | 1.5 | 1.5 | 2.0 | 8.400 | 16.50 | 0.000 | 1.000 |
| OPERATING ENGINEER | | BLD | 4 | 28.100 | 36.650 | 1.5 | 1.5 | 2.0 | 8.400 | 16.50 | 0.000 | 1.000 |
| OPERATING ENGINEER | | BLD | 5 | 27.770 | 36.650 | 1.5 | 1.5 | 2.0 | 8.400 | 16.50 | 0.000 | 1.000 |
| OPERATING ENGINEER | | BLD | 6 | 34.200 | 36.650 | 1.5 | 1.5 | 2.0 | 8.400 | 16.50 | 0.000 | 1.000 |
| OPERATING ENGINEER | | BLD | 7 | 34.500 | 36.650 | 1.5 | 1.5 | 2.0 | 8.400 | 16.50 | 0.000 | 1.000 |
| OPERATING ENGINEER | | BLD | 8 | 34.780 | 36.650 | 1.5 | 1.5 | 2.0 | 8.400 | 16.50 | 0.000 | 1.000 |
| OPERATING ENGINEER | | BLD | 9 | 35.650 | 36.650 | 1.5 | 1.5 | 2.0 | 8.400 | 16.50 | 0.000 | 1.000 |
| OPERATING ENGINEER | | HWY | 1 | 32.150 | 35.150 | 1.5 | 1.5 | 2.0 | 8.400 | 16.50 | 0.000 | 1.000 |
| OPERATING ENGINEER | | HWY | 2 | 31.020 | 35.150 | 1.5 | 1.5 | 2.0 | 8.400 | 16.50 | 0.000 | 1.000 |
| OPERATING ENGINEER | | HWY | 3 | 26.540 | 35.150 | 1.5 | 1.5 | 2.0 | 8.400 | 16.50 | 0.000 | 1.000 |
| OPERATING ENGINEER | | HWY | 4 | 26.600 | 35.150 | 1.5 | 1.5 | 2.0 | 8.400 | 16.50 | 0.000 | 1.000 |
| OPERATING ENGINEER | | HWY | 5 | 26.270 | 35.150 | 1.5 | 1.5 | 2.0 | 8.400 | 16.50 | 0.000 | 1.000 |
| OPERATING ENGINEER | | HWY | 6 | 32.700 | 35.150 | 1.5 | 1.5 | 2.0 | 8.400 | 16.50 | 0.000 | 1.000 |
| OPERATING ENGINEER | | HWY | 7 | 33.000 | 35.150 | 1.5 | 1.5 | 2.0 | 8.400 | 16.50 | 0.000 | 1.000 |
| OPERATING ENGINEER | | HWY | 8 | 33.280 | 35.150 | 1.5 | 1.5 | 2.0 | 8.400 | 16.50 | 0.000 | 1.000 |
| OPERATING ENGINEER | | HWY | 9 | 34.150 | 35.150 | 1.5 | 1.5 | 2.0 | 8.400 | 16.50 | 0.000 | 1.000 |
| PAINTER | | BLD | | 26.260 | 27.760 | 1.5 | 1.5 | 2.0 | 6.380 | 7.070 | 0.000 | 0.500 |
| PAINTER | | HWY | | 30.560 | 32.060 | 1.5 | 1.5 | 2.0 | 6.380 | 7.070 | 0.000 | 0.500 |
| PAINTER OVER 30FT | | BLD | | 27.260 | 28.760 | 1.5 | 1.5 | 2.0 | 6.380 | 7.070 | 0.000 | 0.500 |
| PAINTER PWR EQMT | | BLD | | 27.260 | 28.760 | 1.5 | 1.5 | 2.0 | 6.380 | 7.070 | 0.000 | 0.500 |
| PAINTER PWR EQMT | | HWY | | 31.560 | 33.060 | 1.5 | 1.5 | 2.0 | 6.380 | 7.070 | 0.000 | 0.500 |
| PILEDRIVER | | ALL | | 33.880 | 35.380 | 1.5 | 1.5 | 2.0 | 6.300 | 6.250 | 0.000 | 0.400 |
| PIPEFITTER | N | BLD | | 35.350 | 37.850 | 1.5 | 1.5 | 2.0 | 7.500 | 5.400 | 0.000 | 0.575 |
| PIPEFITTER | SE | BLD | | 39.760 | 43.740 | 1.5 | 2.0 | 2.0 | 8.100 | 5.590 | 0.000 | 1.150 |
| PIPEFITTER | W | BLD | | 36.000 | 38.000 | 1.5 | 1.5 | 2.0 | 6.690 | 8.000 | 0.000 | 0.750 |
| PLASTERER | | BLD | | 27.250 | 28.750 | 1.5 | 1.5 | 2.0 | 6.400 | 5.400 | 0.000 | 0.500 |
| PLUMBER | N | BLD | | 35.350 | 37.850 | 1.5 | 1.5 | 2.0 | 7.500 | 5.400 | 0.000 | 0.575 |
| PLUMBER | SE | BLD | | 39.760 | 43.740 | 1.5 | 2.0 | 2.0 | 8.100 | 5.590 | 0.000 | 1.150 |
| PLUMBER | W | BLD | | 35.150 | 37.650 | 1.5 | 1.5 | 2.0 | 6.000 | 6.600 | 0.000 | 0.400 |

| | | | | | | | | | | |
|-------------------|-------|--------|--------|-----|-----|-----|-------|-------|-------|-------|
| ROOFER | BLD | 28.650 | 30.650 | 1.5 | 1.5 | 2.0 | 8.150 | 6.650 | 0.000 | 0.200 |
| SHEETMETAL WORKER | ALL | 31.690 | 33.190 | 1.5 | 1.5 | 2.0 | 7.130 | 6.730 | 1.910 | 0.360 |
| SPRINKLER FITTER | BLD | 37.830 | 40.830 | 2.0 | 2.0 | 2.0 | 8.550 | 10.35 | 0.000 | 0.850 |
| STONE MASON | BLD | 28.620 | 30.120 | 1.5 | 1.5 | 2.0 | 8.200 | 7.030 | 0.000 | 0.430 |
| TERRAZZO FINISHER | BLD | 27.120 | 0.000 | 1.5 | 1.5 | 2.0 | 8.200 | 7.030 | 0.000 | 0.430 |
| TERRAZZO MASON | BLD | 28.620 | 30.120 | 1.5 | 1.5 | 2.0 | 8.200 | 7.030 | 0.000 | 0.430 |
| TRUCK DRIVER | ALL 1 | 30.460 | 0.000 | 1.5 | 1.5 | 2.0 | 10.05 | 4.775 | 0.000 | 0.250 |
| TRUCK DRIVER | ALL 2 | 30.890 | 0.000 | 1.5 | 1.5 | 2.0 | 10.05 | 4.775 | 0.000 | 0.250 |
| TRUCK DRIVER | ALL 3 | 31.120 | 0.000 | 1.5 | 1.5 | 2.0 | 10.05 | 4.775 | 0.000 | 0.250 |
| TRUCK DRIVER | ALL 4 | 31.380 | 0.000 | 1.5 | 1.5 | 2.0 | 10.05 | 4.775 | 0.000 | 0.250 |
| TRUCK DRIVER | ALL 5 | 32.200 | 0.000 | 1.5 | 1.5 | 2.0 | 10.05 | 4.775 | 0.000 | 0.250 |
| TRUCK DRIVER | O&C 1 | 24.370 | 0.000 | 1.5 | 1.5 | 2.0 | 10.05 | 4.775 | 0.000 | 0.250 |
| TRUCK DRIVER | O&C 2 | 24.710 | 0.000 | 1.5 | 1.5 | 2.0 | 10.05 | 4.775 | 0.000 | 0.250 |
| TRUCK DRIVER | O&C 3 | 24.900 | 0.000 | 1.5 | 1.5 | 2.0 | 10.05 | 4.775 | 0.000 | 0.250 |
| TRUCK DRIVER | O&C 4 | 25.100 | 0.000 | 1.5 | 1.5 | 2.0 | 10.05 | 4.775 | 0.000 | 0.250 |
| TRUCK DRIVER | O&C 5 | 25.760 | 0.000 | 1.5 | 1.5 | 2.0 | 10.05 | 4.775 | 0.000 | 0.250 |
| TUCKPOINTER | BLD | 28.620 | 30.120 | 1.5 | 1.5 | 2.0 | 8.200 | 7.030 | 0.000 | 0.430 |

Legend :

RG (Region)

TYP (Trade Type - All,Highway,Building,Floating,Oil & Chip,Rivers)

C (Class)

Base (Base Wage Rate)

FRMAN (Foreman Rate)

M-F>8 (OT required for any hour greater than 8 worked each day, Mon through Fri.

OSA (Overtime (OT) is required for every hour worked on Saturday)

OSH (Overtime is required for every hour worked on Sunday and Holidays)

H/W (Health & Welfare Insurance)

Pensn (Pension)

Vac (Vacation)

Trng (Training)

Explanations

RANDOLPH COUNTY

ELECTRICIANS AND ELECTRONIC SYSTEMS TECHNICIAN (NORTHWEST) - Township of Red Bud.

PLUMBERS & PIPEFITTERS (NORTH) - Towns of Red Bud, Prairie, and Ruma.

PLUMBERS & PIPEFITTERS (SOUTHEAST) - That part of the county East of a line between Ste. Genevieve, Mo. and Rt. 155 then south of a diagonal line to the North-East corner of the county.

PLUMBERS & PIPEFITTERS (WEST) - Towns of Roots, Kellog, Modoc and Prairie DuRocher.

The following list is considered as those days for which holiday rates of wages for work performed apply: New Years Day, Memorial Day, Fourth of July, Labor Day, Thanksgiving Day, Christmas Day and Veterans Day in some classifications/counties. Generally, any of these holidays which fall on a Sunday is celebrated on the following Monday. This then makes work performed on that Monday payable at the appropriate overtime rate for holiday pay. Common practice in a given local may alter certain days of celebration. If in doubt, please check with IDOL.

Oil and chip resealing (O&C) means the application of road oils and liquid asphalt to coat an existing road surface, followed by application of aggregate chips or gravel to coated surface, and subsequent rolling of material to seal the surface.

EXPLANATION OF CLASSES

ASBESTOS - GENERAL - removal of asbestos material/mold and hazardous materials from any place in a building, including mechanical systems where those mechanical systems are to be removed. This includes the removal of asbestos materials/mold and hazardous materials from ductwork or pipes in a building when the building is to be demolished at the time or at some close future date.

ASBESTOS - MECHANICAL - removal of asbestos material from mechanical systems, such as pipes, ducts, and boilers, where the mechanical systems are to remain.

CERAMIC TILE FINISHER, MARBLE FINISHER, TERRAZZO FINISHER

Assisting, helping or supporting the tile, marble and terrazzo mechanic by performing their historic and traditional work assignments required to complete the proper installation of the work covered by said crafts. The term "Ceramic" is used for naming the classification only, and is in no a limitation of the product handled. Ceramic takes into consideration most hard tiles.

ELECTRONIC SYSTEMS TECHNICIAN

Installation, service and maintenance of low-voltage systems which utilizes the transmission and/or transference of voice, sound, vision, or digital for commercial, education, security and entertainment purposes for the following: TV monitoring and surveillance, background/foreground music, intercom and telephone interconnect, field programming, inventory control systems, microwave transmission, multi-media, multiplex, radio page, school, intercom and sound burglar alarms and low voltage master clock systems.

Excluded from this classification are energy management systems, life safety systems, supervisory controls and data acquisition systems not intrinsic with the above listed systems, fire alarm systems, nurse call systems and raceways exceeding fifteen feet in length.

OPERATING ENGINEER - BUILDING

GROUP I. Cranes, Dragline, Shovels, Skimmer Scoops, Clamshells or

Derrick Boats, Pile Drivers, Crane-Type Backhoes, Asphalt Plant Operators, Concrete Plant Operators, Dredges, Asphalt Spreading Machines, All Locomotives, Cable Ways or Tower Machines, Hoists, Hydraulic Backhoes, Ditching Machines or Backfiller, Cherrypickers, Overhead Cranes, Roller - Steam or Gas, Concrete Pavers, Excavators, Concrete Breakers, Concrete Pumps, Bulk Cement Plants, Cement Pumps, Derrick-Type Drills, Boat Operators, Motor Graders or Pushcats, Scoops or Tournapulls, Bulldozers, Endloaders or Fork Lifts, Power Blade or Elevating Graders, Winch Cats, Boom or Winch Trucks or Boom Tractors, Pipe Wrapping or Painting Machines, Asphalt Plant Engineer, Journeyman Lubricating Engineer, Drills (other than Derrick Type), Mud Jacks, or Well Drilling Machines, Boring Machines or Track Jacks, Mixers, Conveyors (Two), Air Compressors (Two), Water Pumps regardless of size (Two), Welding Machines (Two), Siphons or Jets (Two), Winch Heads or Apparatuses (Two), Light Plants (Two), All Tractors regardless of size (straight tractor only), Fireman on Stationary Boilers, Automatic Elevators, Form Grading Machines, Finishing Machines, Power Sub-Grader or Ribbon Machines, Longitudinal Floats, Distributor Operators on Trucks, Winch Heads or Apparatuses (One), Mobil Track air and heaters (two to five), Heavy Equipment Greaser, Relief Operator, Assistant Master Mechanic and Heavy Duty Mechanic, self-propelled concrete saws of all types and sizes with their attachments, gob-hoppers, excavators all sizes, the repair and greasing of all diesel hammers, the operation and set-up of bidwells, water blasters of all sizes and their clutches, hydraulic jacks where used for hoisting, operation of log skidders, iceolators used on and off of pipeline, condor cranes, bow boats, survey boats, bobcats and all their attachments, skid steer loaders and all their attachments, creter cranes, batch plants, operator (all sizes), self propelled roto mills, operation of conveyor systems of any size and any configuration, operation, repair and service of all vibratory hammers, all power pacs and their controls regardless of location, curtains or brush burning machines, stump cutter machines, Nail launchers when mounted on a machine or self-propelled, operation of con-cover machines, and all Operators except those listed below).

GROUP II. Assistant Operators.

GROUP III. Air Compressors (One), Water Pumps, regardless of Size (One), Waterblasters (one), Welding Machine (One), Mixers (One Bag), Conveyor (One), Siphon or Jet (One), Light Plant (One), Heater (One), Immobile Track Air (One), and Self Propelled Walk-Behind Rollers.

GROUP IV. Asphalt Spreader Oilers, Fireman on Whirlies and Heavy Equipment Oilers, Truck Cranes, Dredges, Monigans, Large Cranes - (Over 65-ton rated capacity) Concrete Plant Oiler, Blacktop Plant Oiler, and Creter Crane Oiler (when required).

GROUP V. Oiler.

GROUP VI. Operators on equipment with Booms, including jibs, 100 feet and over, and less than 150 feet long.

GROUP VII. Operators on equipment with Booms, including jibs, 150 feet and over, and less than 200 feet long.

GROUP VIII. Operators on Equipment with Booms, including jibs, 200 feet and over; Tower Cranes; and Whirlie Cranes.

GROUP IX. Master Mechanic

OPERATING ENGINEERS - Highway

GROUP I. Cranes, Dragline, Shovels, Skimmer Scoops, Clamshells or Derrick Boats, Pile Drivers, Crane-Type Backhoes, Asphalt Plant Operators, Concrete Plant Operators, Dredges, Asphalt Spreading Machines, All Locomotives, Cable Ways or Tower Machines, Hoists, Hydraulic Backhoes, Ditching Machines or Backfiller, Cherrypickers, Overhead Cranes, Roller - Steam or Gas, Concrete Pavers, Excavators, Concrete Breakers, Concrete Pumps, Bulk Cement Plants, Cement Pumps, Derrick-Type Drills, Boat Operators, Motor Graders or Pushcats, Scoops or Tournapulls, Bulldozers, Endloaders or Fork Lifts, Power Blade or Elevating Graders, Winch Cats, Boom or Winch Trucks or Boom Tractors, Pipe Wrapping or Painting Machines, Asphalt Plant Engineer, Journeyman Lubricating Engineer, Drills (other than Derrick Type), Mud Jacks, Well Drilling Machines, Boring Machines, Track Jacks, Mixers, Conveyors (Two), Air Compressors (Two), Water Pumps regardless of size (Two), Welding Machines (Two), Siphons or Jets (Two), Winch Heads or Apparatuses (Two), Light Plants (Two), All Tractors regardless of size (straight tractor only), Fireman on Stationary Boilers, Automatic Elevators, Form Grading Machines, Finishing Machines, Power Sub-Grader or Ribbon Machines, Longitudinal Floats, Distributor Operators on Trucks, Winch Heads or Apparatuses (One), Mobil Track air and heaters (two to five), Heavy Equipment Greaser, Relief Operator, Assistant Master Mechanic and Heavy Duty Mechanic, self-propelled concrete saws of all types and sizes with their attachments, gob-hoppers, excavators all sizes, the repair and greasing of all diesel hammers, the operation and set-up of bidwells, water blasters of all sizes and their clutches, hydraulic jacks where used for hoisting, operation of log skidders, iceolators used on and off of pipeline, condor cranes, bow boats, survey boats, bobcats and all their attachments, skid steer loaders and all their attachments, creter cranes, batch plants, operator (all sizes), self propelled roto mills, operation of conveyor systems of any size and any configuration, operation, repair and service of all vibratory hammers, all power pacs and their controls regardless of location, curtains or brush burning machines, stump cutter machines, Nail launchers when mounted on a machine or self-propelled, operation of con-cover machines, and all Operators (except those listed below).

GROUP II. Assistant Operators.

GROUP III. Air Compressors (One), Water Pumps, regardless of Size (One), Waterblasters (one), Welding Machine (One), Mixers (One Bag), Conveyor (One), Siphon or Jet (One), Light Plant (One), Heater (One), Immobile Track Air (One), and Self Propelled Walk-Behind Rollers.

GROUP IV. Asphalt Spreader Oilers, Fireman on Whirlies and Heavy Equipment Oilers, Truck Cranes, Dredges, Monigans, Large Cranes - (Over 65-ton rated capacity) Concrete Plant Oiler, Blacktop Plant Oiler, and Creter Crane Oiler (when required).

GROUP V. Oiler.

GROUP VI. Operators on equipment with Booms, including jibs, 100 feet and over, and less than 150 feet long.

GROUP VII. Operators on equipment with Booms, including jibs, 150 feet and over, and less than 200 feet long.

GROUP VIII. Operators on Equipment with Booms, including jibs, 200 feet and over; Tower Cranes; and Whirlie Cranes.

GROUP IX. Mechanic

TRUCK DRIVER - BUILDING, HEAVY AND HIGHWAY CONSTRUCTION

Class 1. Drivers on 2 axle trucks hauling less than 9 ton. Air compressor and welding machines and brooms, including those pulled by separate units, truck driver helpers, warehouse employees, mechanic helpers, greasers and tiremen, pickup trucks when hauling materials, tools, or workers to and from and on-the-job site, and fork lifts up to 6,000 lb. capacity.

Class 2. Two or three axle trucks hauling more than 9 ton but hauling less than 16 ton. A-frame winch trucks, hydrolift trucks, vector trucks or similar equipment when used for transportation purposes. Fork lifts over 6,000 lb. capacity, winch trucks, four axle combination units, and ticket writers.

Class 3. Two, three or four axle trucks hauling 16 ton or more. Drivers on water pulls, articulated dump trucks, mechanics and working forepersons, and dispatchers. Five axle or more combination units.

Class 4. Low Boy and Oil Distributors.

Class 5. Drivers who require special protective clothing while employed on hazardous waste work.

TRUCK DRIVER - OIL AND CHIP RESEALING ONLY.

This shall encompass laborers, workers and mechanics who drive contractor or subcontractor owned, leased, or hired pickup, dump, service, or oil distributor trucks. The work includes transporting materials and equipment (including but not limited to, oils, aggregate supplies, parts, machinery and tools) to or from the job site; distributing oil or liquid asphalt and aggregate; stock piling material when in connection with the actual oil and chip contract. The Truck Driver (Oil & Chip Resealing) wage classification does not include supplier delivered materials.

Other Classifications of Work:

For definitions of classifications not otherwise set out, the Department generally has on file such definitions which are available. If a task to be performed is not subject to one of the classifications of pay set out, the Department will upon being contacted state which neighboring county has such a classification and provide such rate, such rate being deemed to exist by reference in this document. If no neighboring county rate applies to the task, the Department shall undertake a special determination, such special determination being then deemed to have existed under this determination. If a project requires these, or any classification not listed, please contact IDOL at 217-782-1710 for wage rates or clarifications.

LANDSCAPING

Landscaping work falls under the existing classifications for laborer, operating engineer and truck driver. The work performed by landscape plantsman and landscape laborer is covered by the existing classification of laborer. The work performed by landscape operators (regardless of equipment used or its size) is covered by the classifications of operating engineer. The work performed by landscape truck drivers (regardless of size of truck driven) is covered by the classifications of truck driver.

Saint Clair County Prevailing Wage for May 2012

(See explanation of column headings at bottom of wages)

| Trade Name | RG | TYP | C | Base | FRMAN | *M-F>8 | OSA | OSH | H/W | Pensn | Vac | Trng |
|----------------------|----|-------|---|--------|--------|--------|-----|-----|-------|-------|-------|-------|
| ===== | == | === | = | ===== | ===== | ===== | === | === | ===== | ===== | ===== | ===== |
| ASBESTOS ABT-GEN | | BLD | | 28.800 | 29.300 | 1.5 | 1.5 | 2.0 | 5.550 | 10.35 | 0.000 | 0.800 |
| ASBESTOS ABT-MEC | | BLD | | 29.160 | 30.160 | 1.5 | 1.5 | 2.0 | 6.700 | 2.750 | 0.000 | 0.000 |
| BOILERMAKER | | BLD | | 31.500 | 34.000 | 1.5 | 1.5 | 2.0 | 7.070 | 18.73 | 1.000 | 0.350 |
| BRICK MASON | | BLD | | 28.790 | 30.640 | 1.5 | 1.5 | 2.0 | 7.500 | 9.430 | 2.000 | 0.400 |
| CARPENTER | | ALL | | 33.880 | 35.380 | 1.5 | 1.5 | 2.0 | 6.300 | 6.250 | 0.000 | 0.400 |
| CEMENT MASON | | ALL | | 31.000 | 32.000 | 1.5 | 1.5 | 2.0 | 8.750 | 11.00 | 0.000 | 0.200 |
| CERAMIC TILE FNSHER | | BLD | | 25.520 | 0.000 | 1.5 | 1.5 | 2.0 | 5.900 | 5.110 | 0.000 | 0.470 |
| ELECTRIC PWR EQMT OP | | ALL | | 34.800 | 0.000 | 1.5 | 2.0 | 2.0 | 5.850 | 9.750 | 0.000 | 0.260 |
| ELECTRIC PWR GRNDMAN | | ALL | | 25.980 | 0.000 | 1.5 | 2.0 | 2.0 | 4.370 | 7.280 | 0.000 | 0.190 |
| ELECTRIC PWR LINEMAN | | ALL | | 40.020 | 41.950 | 1.5 | 2.0 | 2.0 | 6.720 | 11.21 | 0.000 | 0.300 |
| ELECTRIC PWR TRK DRV | | ALL | | 28.410 | 0.000 | 1.5 | 2.0 | 2.0 | 4.780 | 7.950 | 0.000 | 0.210 |
| ELECTRICIAN | | ALL | | 36.510 | 38.700 | 1.5 | 1.5 | 2.0 | 7.210 | 7.490 | 0.000 | 0.640 |
| ELECTRONIC SYS TECH | | BLD | | 29.920 | 31.670 | 1.5 | 1.5 | 2.0 | 3.200 | 7.400 | 0.000 | 0.250 |
| ELEVATOR CONSTRUCTOR | | BLD | | 43.345 | 48.760 | 2.0 | 2.0 | 2.0 | 11.03 | 11.96 | 2.600 | 0.000 |
| FLOOR LAYER | | BLD | | 29.080 | 29.830 | 1.5 | 1.5 | 2.0 | 6.300 | 6.250 | 0.000 | 0.400 |
| GLAZIER | | BLD | | 32.780 | 0.000 | 2.0 | 2.0 | 2.0 | 9.020 | 10.80 | 2.630 | 0.310 |
| HT/FROST INSULATOR | | BLD | | 36.760 | 37.760 | 1.5 | 1.5 | 2.0 | 7.550 | 10.76 | 0.000 | 0.500 |
| IRON WORKER | | ALL | | 31.000 | 33.000 | 1.5 | 1.5 | 2.0 | 7.110 | 12.35 | 0.000 | 0.420 |
| LABORER | N | ALL | | 28.300 | 28.800 | 1.5 | 1.5 | 2.0 | 5.550 | 10.35 | 0.000 | 0.800 |
| LABORER | S | ALL | | 26.310 | 26.810 | 1.5 | 1.5 | 2.0 | 5.550 | 12.34 | 0.000 | 0.800 |
| MACHINIST | | BLD | | 43.160 | 45.160 | 1.5 | 1.5 | 2.0 | 7.980 | 8.950 | 0.000 | 0.000 |
| MARBLE FINISHERS | | BLD | | 25.520 | 0.000 | 1.5 | 1.5 | 2.0 | 5.900 | 5.110 | 0.000 | 0.470 |
| MARBLE MASON | | BLD | | 28.790 | 30.640 | 1.5 | 1.5 | 2.0 | 7.500 | 9.430 | 2.000 | 0.400 |
| MILLWRIGHT | | ALL | | 33.880 | 35.380 | 1.5 | 1.5 | 2.0 | 6.300 | 6.250 | 0.000 | 0.400 |
| OPERATING ENGINEER | | BLD 1 | | 33.650 | 36.650 | 1.5 | 1.5 | 2.0 | 8.400 | 16.50 | 0.000 | 1.000 |
| OPERATING ENGINEER | | BLD 2 | | 32.520 | 36.650 | 1.5 | 1.5 | 2.0 | 8.400 | 16.50 | 0.000 | 1.000 |
| OPERATING ENGINEER | | BLD 3 | | 28.040 | 36.650 | 1.5 | 1.5 | 2.0 | 8.400 | 16.50 | 0.000 | 1.000 |
| OPERATING ENGINEER | | BLD 4 | | 28.100 | 36.650 | 1.5 | 1.5 | 2.0 | 8.400 | 16.50 | 0.000 | 1.000 |
| OPERATING ENGINEER | | BLD 5 | | 27.770 | 36.650 | 1.5 | 1.5 | 2.0 | 8.400 | 16.50 | 0.000 | 1.000 |
| OPERATING ENGINEER | | BLD 6 | | 34.200 | 36.650 | 1.5 | 1.5 | 2.0 | 8.400 | 16.50 | 0.000 | 1.000 |
| OPERATING ENGINEER | | BLD 7 | | 34.500 | 36.650 | 1.5 | 1.5 | 2.0 | 8.400 | 16.50 | 0.000 | 1.000 |
| OPERATING ENGINEER | | BLD 8 | | 34.780 | 36.650 | 1.5 | 1.5 | 2.0 | 8.400 | 16.50 | 0.000 | 1.000 |
| OPERATING ENGINEER | | BLD 9 | | 35.650 | 36.650 | 1.5 | 1.5 | 2.0 | 8.400 | 16.50 | 0.000 | 1.000 |
| OPERATING ENGINEER | | HWY 1 | | 32.150 | 35.150 | 1.5 | 1.5 | 2.0 | 8.400 | 16.50 | 0.000 | 1.000 |
| OPERATING ENGINEER | | HWY 2 | | 31.020 | 35.150 | 1.5 | 1.5 | 2.0 | 8.400 | 16.50 | 0.000 | 1.000 |
| OPERATING ENGINEER | | HWY 3 | | 26.540 | 35.150 | 1.5 | 1.5 | 2.0 | 8.400 | 16.50 | 0.000 | 1.000 |
| OPERATING ENGINEER | | HWY 4 | | 26.600 | 35.150 | 1.5 | 1.5 | 2.0 | 8.400 | 16.50 | 0.000 | 1.000 |
| OPERATING ENGINEER | | HWY 5 | | 26.270 | 35.150 | 1.5 | 1.5 | 2.0 | 8.400 | 16.50 | 0.000 | 1.000 |
| OPERATING ENGINEER | | HWY 6 | | 32.700 | 35.150 | 1.5 | 1.5 | 2.0 | 8.400 | 16.50 | 0.000 | 1.000 |
| OPERATING ENGINEER | | HWY 7 | | 33.000 | 35.150 | 1.5 | 1.5 | 2.0 | 8.400 | 16.50 | 0.000 | 1.000 |
| OPERATING ENGINEER | | HWY 8 | | 33.280 | 35.150 | 1.5 | 1.5 | 2.0 | 8.400 | 16.50 | 0.000 | 1.000 |
| OPERATING ENGINEER | | HWY 9 | | 34.150 | 35.150 | 1.5 | 1.5 | 2.0 | 8.400 | 16.50 | 0.000 | 1.000 |
| PAINTER | | BLD | | 29.250 | 30.750 | 1.5 | 1.5 | 2.0 | 5.000 | 7.920 | 0.000 | 0.600 |
| PAINTER | | HWY | | 30.450 | 31.950 | 1.5 | 1.5 | 2.0 | 5.000 | 7.920 | 0.000 | 0.600 |
| PAINTER OVER 30FT | | BLD | | 30.250 | 31.750 | 1.5 | 1.5 | 2.0 | 5.000 | 7.920 | 0.000 | 0.600 |
| PAINTER PWR EQMT | | BLD | | 30.250 | 31.750 | 1.5 | 1.5 | 2.0 | 5.000 | 7.920 | 0.000 | 0.600 |
| PAINTER PWR EQMT | | HWY | | 31.450 | 32.950 | 1.5 | 1.5 | 2.0 | 5.000 | 7.920 | 0.000 | 0.600 |
| PILEDRIVER | | ALL | | 33.880 | 35.380 | 1.5 | 1.5 | 2.0 | 6.300 | 6.250 | 0.000 | 0.400 |
| PIPEFITTER | NW | BLD | | 36.000 | 38.000 | 1.5 | 1.5 | 2.0 | 6.690 | 8.000 | 0.000 | 0.750 |
| PIPEFITTER | SE | BLD | | 35.350 | 37.850 | 1.5 | 1.5 | 2.0 | 7.500 | 5.400 | 0.000 | 0.575 |
| PLASTERER | | BLD | | 30.250 | 31.250 | 1.5 | 1.5 | 2.0 | 8.750 | 8.300 | 0.000 | 0.050 |
| PLUMBER | NW | BLD | | 35.150 | 37.650 | 1.5 | 1.5 | 2.0 | 6.000 | 6.600 | 0.000 | 0.400 |
| PLUMBER | SE | BLD | | 35.350 | 37.850 | 1.5 | 1.5 | 2.0 | 7.500 | 5.400 | 0.000 | 0.575 |
| ROOFER | | BLD | | 28.650 | 30.650 | 1.5 | 1.5 | 2.0 | 8.150 | 6.650 | 0.000 | 0.200 |
| SHEETMETAL WORKER | | ALL | | 31.690 | 33.190 | 1.5 | 1.5 | 2.0 | 7.130 | 6.730 | 1.910 | 0.360 |
| SPRINKLER FITTER | | BLD | | 37.830 | 40.830 | 2.0 | 2.0 | 2.0 | 8.550 | 10.35 | 0.000 | 0.850 |
| TERRAZZO FINISHER | | BLD | | 31.240 | 0.000 | 1.5 | 1.5 | 2.0 | 5.900 | 2.730 | 0.000 | 0.130 |

| | | | | | | | | | | |
|----------------|-------|--------|--------|-----|-----|-----|-------|-------|-------|-------|
| TERRAZZO MASON | BLD | 32.530 | 32.830 | 1.5 | 1.5 | 2.0 | 5.900 | 4.980 | 0.000 | 0.140 |
| TRUCK DRIVER | ALL 1 | 30.460 | 0.000 | 1.5 | 1.5 | 2.0 | 10.05 | 4.775 | 0.000 | 0.250 |
| TRUCK DRIVER | ALL 2 | 30.890 | 0.000 | 1.5 | 1.5 | 2.0 | 10.05 | 4.775 | 0.000 | 0.250 |
| TRUCK DRIVER | ALL 3 | 31.120 | 0.000 | 1.5 | 1.5 | 2.0 | 10.05 | 4.775 | 0.000 | 0.250 |
| TRUCK DRIVER | ALL 4 | 31.380 | 0.000 | 1.5 | 1.5 | 2.0 | 10.05 | 4.775 | 0.000 | 0.250 |
| TRUCK DRIVER | ALL 5 | 32.200 | 0.000 | 1.5 | 1.5 | 2.0 | 10.05 | 4.775 | 0.000 | 0.250 |
| TRUCK DRIVER | O&C 1 | 24.370 | 0.000 | 1.5 | 1.5 | 2.0 | 10.05 | 4.775 | 0.000 | 0.250 |
| TRUCK DRIVER | O&C 2 | 24.710 | 0.000 | 1.5 | 1.5 | 2.0 | 10.05 | 4.775 | 0.000 | 0.250 |
| TRUCK DRIVER | O&C 3 | 24.900 | 0.000 | 1.5 | 1.5 | 2.0 | 10.05 | 4.775 | 0.000 | 0.250 |
| TRUCK DRIVER | O&C 4 | 25.100 | 0.000 | 1.5 | 1.5 | 2.0 | 10.05 | 4.775 | 0.000 | 0.250 |
| TRUCK DRIVER | O&C 5 | 25.760 | 0.000 | 1.5 | 1.5 | 2.0 | 10.05 | 4.775 | 0.000 | 0.250 |

Legend :

RG (Region)

TYP (Trade Type - All,Highway,Building,Floating,Oil & Chip,Rivers)

C (Class)

Base (Base Wage Rate)

FRMAN (Foreman Rate)

M-F>8 (OT required for any hour greater than 8 worked each day, Mon through Fri.

OSA (Overtime (OT) is required for every hour worked on Saturday)

OSH (Overtime is required for every hour worked on Sunday and Holidays)

H/W (Health & Welfare Insurance)

Pensn (Pension)

Vac (Vacation)

Trng (Training)

Explanations

ST. CLAIR COUNTY

LABORERS (NORTH) - The area bounded by Route 159 to a point south of Fairview Heights and west-southwest to Route 3 at Monroe County line.

PLUMBERS & PIPEFITTERS (SOUTHEAST) - That part of the county bordered by Rt. 50 on the North and West including Belleville.

PLUMBERS (NORTHWEST) - Towns of Aloraton, Brooklyn, Cahokia, Caseyville, Centreville, Dupo, East Carondelet, E. St. Louis, Fairview Heights, French Village, National City, O'Fallon, Sauget, and Washington Park.

The following list is considered as those days for which holiday rates of wages for work performed apply: New Years Day, Memorial Day, Fourth of July, Labor Day, Thanksgiving Day, Christmas Day and Veterans Day in some classifications/counties. Generally, any of these holidays which fall on a Sunday is celebrated on the following Monday. This then makes work performed on that Monday payable at the appropriate overtime rate for holiday pay. Common practice in a given local may alter certain days of celebration. If in doubt, please check with IDOL.

Oil and chip resealing (O&C) means the application of road oils and liquid asphalt to coat an existing road surface, followed by application of aggregate chips or gravel to coated surface, and subsequent rolling of material to seal the surface.

EXPLANATION OF CLASSES

ASBESTOS - GENERAL - removal of asbestos material/mold and hazardous materials from any place in a building, including mechanical systems where those mechanical systems are to be removed. This includes the removal of asbestos materials/mold and hazardous materials from ductwork or pipes in a building when the building is to be demolished at the time or at some close future date.

ASBESTOS - MECHANICAL - removal of asbestos material from mechanical systems, such as pipes, ducts, and boilers, where the mechanical systems are to remain.

CERAMIC TILE FINISHER AND MARBLE FINISHER

The handling, at the building site, of all sand, cement, tile, marble or stone and all other materials that may be used and installed by [a] tile layer or marble mason. In addition, the grouting, cleaning, sealing, and mixing on the job site, and all other work as required in assisting the setter. The term "Ceramic" is used for naming the classification only and is in no way a limitation of the product handled. Ceramic takes into consideration most hard tiles.

ELECTRONIC SYSTEMS TECHNICIAN

Installation, service and maintenance of low-voltage systems which utilizes the transmission and/or transference of voice, sound, vision, or digital for commercial, education, security and entertainment purposes for the following: TV monitoring and surveillance, background/foreground music, intercom and telephone interconnect, field programming, inventory control systems, microwave transmission, multi-media, multiplex, radio page, school, intercom and sound burglar alarms and low voltage master clock systems.

Excluded from this classification are energy management systems, life safety systems, supervisory controls and data acquisition systems not intrinsic with the above listed systems, fire alarm systems, nurse call systems and raceways exceeding fifteen feet in length.

OPERATING ENGINEER - BUILDING

GROUP I. Cranes, Dragline, Shovels, Skimmer Scoops, Clamshells or Derrick Boats, Pile Drivers, Crane-Type Backhoes, Asphalt Plant Operators, Concrete Plant Operators, Dredges, Asphalt Spreading Machines, All Locomotives, Cable Ways or Tower Machines, Hoists, Hydraulic Backhoes, Ditching Machines or Backfiller, Cherrypickers,

Overhead Cranes, Roller - Steam or Gas, Concrete Pavers, Excavators, Concrete Breakers, Concrete Pumps, Bulk Cement Plants, Cement Pumps, Derrick-Type Drills, Boat Operators, Motor Graders or Pushcats, Scoops or Tournapulls, Bulldozers, Endloaders or Fork Lifts, Power Blade or Elevating Graders, Winch Cats, Boom or Winch Trucks or Boom Tractors, Pipe Wrapping or Painting Machines, Asphalt Plant Engineer, Journeyman Lubricating Engineer, Drills (other than Derrick Type), Mud Jacks, or Well Drilling Machines, Boring Machines or Track Jacks, Mixers, Conveyors (Two), Air Compressors (Two), Water Pumps regardless of size (Two), Welding Machines (Two), Siphons or Jets (Two), Winch Heads or Apparatuses (Two), Light Plants (Two), All Tractors regardless of size (straight tractor only), Fireman on Stationary Boilers, Automatic Elevators, Form Grading Machines, Finishing Machines, Power Sub-Grader or Ribbon Machines, Longitudinal Floats, Distributor Operators on Trucks, Winch Heads or Apparatuses (One), Mobil Track air and heaters (two to five), Heavy Equipment Greaser, Relief Operator, Assistant Master Mechanic and Heavy Duty Mechanic, self-propelled concrete saws of all types and sizes with their attachments, gob-hoppers, excavators all sizes, the repair and greasing of all diesel hammers, the operation and set-up of bidwells, water blasters of all sizes and their clutches, hydraulic jacks where used for hoisting, operation of log skidders, iceolators used on and off of pipeline, condor cranes, bow boats, survey boats, bobcats and all their attachments, skid steer loaders and all their attachments, creter cranes, batch plants, operator (all sizes), self propelled roto mills, operation of conveyor systems of any size and any configuration, operation, repair and service of all vibratory hammers, all power pacs and their controls regardless of location, curtains or brush burning machines, stump cutter machines, Nail launchers when mounted on a machine or self-propelled, operation of con-cover machines, and all Operators except those listed below).

GROUP II. Assistant Operators.

GROUP III. Air Compressors (One), Water Pumps, regardless of Size (One), Waterblasters (one), Welding Machine (One), Mixers (One Bag), Conveyor (One), Siphon or Jet (One), Light Plant (One), Heater (One), Immobile Track Air (One), and Self Propelled Walk-Behind Rollers.

GROUP IV. Asphalt Spreader Oilers, Fireman on Whirlies and Heavy Equipment Oilers, Truck Cranes, Dredges, Monigans, Large Cranes - (Over 65-ton rated capacity) Concrete Plant Oiler, Blacktop Plant Oiler, and Creter Crane Oiler (when required).

GROUP V. Oiler.

GROUP VI. Operators on equipment with Booms, including jibs, 100 feet and over, and less than 150 feet long.

GROUP VII. Operators on equipment with Booms, including jibs, 150 feet and over, and less than 200 feet long.

GROUP VIII. Operators on Equipment with Booms, including jibs, 200 feet and over; Tower Cranes; and Whirlie Cranes.

GROUP IX. Master Mechanic

OPERATING ENGINEERS - Highway

GROUP I. Cranes, Dragline, Shovels, Skimmer Scoops, Clamshells or Derrick Boats, Pile Drivers, Crane-Type Backhoes, Asphalt Plant Operators, Concrete Plant Operators, Dredges, Asphalt Spreading Machines, All Locomotives, Cable Ways or Tower Machines, Hoists,

Hydraulic Backhoes, Ditching Machines or Backfiller, Cherrypickers, Overhead Cranes, Roller - Steam or Gas, Concrete Pavers, Excavators, Concrete Breakers, Concrete Pumps, Bulk Cement Plants, Cement Pumps, Derrick-Type Drills, Boat Operators, Motor Graders or Pushcats, Scoops or Tournapulls, Bulldozers, Endloaders or Fork Lifts, Power Blade or Elevating Graders, Winch Cats, Boom or Winch Trucks or Boom Tractors, Pipe Wrapping or Painting Machines, Asphalt Plant Engineer, Journeyman Lubricating Engineer, Drills (other than Derrick Type), Mud Jacks, Well Drilling Machines, Boring Machines, Track Jacks, Mixers, Conveyors (Two), Air Compressors (Two), Water Pumps regardless of size (Two), Welding Machines (Two), Siphons or Jets (Two), Winch Heads or Apparatuses (Two), Light Plants (Two), All Tractors regardless of size (straight tractor only), Fireman on Stationary Boilers, Automatic Elevators, Form Grading Machines, Finishing Machines, Power Sub-Grader or Ribbon Machines, Longitudinal Floats, Distributor Operators on Trucks, Winch Heads or Apparatuses (One), Mobil Track air and heaters (two to five), Heavy Equipment Greaser, Relief Operator, Assistant Master Mechanic and Heavy Duty Mechanic, self-propelled concrete saws of all types and sizes with their attachments, gob-hoppers, excavators all sizes, the repair and greasing of all diesel hammers, the operation and set-up of bidwells, water blasters of all sizes and their clutches, hydraulic jacks where used for hoisting, operation of log skidders, iceolators used on and off of pipeline, condor cranes, bow boats, survey boats, bobcats and all their attachments, skid steer loaders and all their attachments, creter cranes, batch plants, operator (all sizes), self propelled roto mills, operation of conveyor systems of any size and any configuration, operation, repair and service of all vibratory hammers, all power pacs and their controls regardless of location, curtains or brush burning machines, stump cutter machines, Nail launchers when mounted on a machine or self-propelled, operation of con-cover machines, and all Operators (except those listed below).

GROUP II. Assistant Operators.

GROUP III. Air Compressors (One), Water Pumps, regardless of Size (One), Waterblasters (one), Welding Machine (One), Mixers (One Bag), Conveyor (One), Siphon or Jet (One), Light Plant (One), Heater (One), Immobile Track Air (One), and Self Propelled Walk-Behind Rollers.

GROUP IV. Asphalt Spreader Oilers, Fireman on Whirlies and Heavy Equipment Oilers, Truck Cranes, Dredges, Monigans, Large Cranes - (Over 65-ton rated capacity) Concrete Plant Oiler, Blacktop Plant Oiler, and Creter Crane Oiler (when required).

GROUP V. Oiler.

GROUP VI. Operators on equipment with Booms, including jibs, 100 feet and over, and less than 150 feet long.

GROUP VII. Operators on equipment with Booms, including jibs, 150 feet and over, and less than 200 feet long.

GROUP VIII. Operators on Equipment with Booms, including jibs, 200 feet and over; Tower Cranes; and Whirlie Cranes.

GROUP IX. Mechanic

TRUCK DRIVER - BUILDING, HEAVY AND HIGHWAY CONSTRUCTION

Class 1. Drivers on 2 axle trucks hauling less than 9 ton. Air compressor and welding machines and brooms, including those pulled by

separate units, truck driver helpers, warehouse employees, mechanic helpers, greasers and tiremen, pickup trucks when hauling materials, tools, or workers to and from and on-the-job site, and fork lifts up to 6,000 lb. capacity.

Class 2. Two or three axle trucks hauling more than 9 ton but hauling less than 16 ton. A-frame winch trucks, hydrolift trucks, vactor trucks or similar equipment when used for transportation purposes. Fork lifts over 6,000 lb. capacity, winch trucks, four axle combination units, and ticket writers.

Class 3. Two, three or four axle trucks hauling 16 ton or more. Drivers on water pulls, articulated dump trucks, mechanics and working forepersons, and dispatchers. Five axle or more combination units.

Class 4. Low Boy and Oil Distributors.

Class 5. Drivers who require special protective clothing while employed on hazardous waste work.

TRUCK DRIVER - OIL AND CHIP RESEALING ONLY.

This shall encompass laborers, workers and mechanics who drive contractor or subcontractor owned, leased, or hired pickup, dump, service, or oil distributor trucks. The work includes transporting materials and equipment (including but not limited to, oils, aggregate supplies, parts, machinery and tools) to or from the job site; distributing oil or liquid asphalt and aggregate; stock piling material when in connection with the actual oil and chip contract. The Truck Driver (Oil & Chip Resealing) wage classification does not include supplier delivered materials.

TERRAZZO FINISHER

The handling of all materials used for Mosaic and Terrazzo work including preparing, mixing by hand, by mixing machine or transporting of pre-mixed materials and distributing with shovel, rake, hoe, or pail, all kinds of concrete foundations necessary for Mosaic and Terrazzo work, all cement terrazzo, magnesite terrazzo, Do-O-Tex terrazzo, epoxy matrix ter-razzo, exposed aggregate, rustic or rough washed for exterior or interior of buildings placed either by machine or by hand, and any other kind of mixture of plastics composed of chips or granules when mixed with cement, rubber, neoprene, vinyl, magnesium chloride or any other resinous or chemical substances used for seamless flooring systems, and all other building materials, all similar materials and all precast terrazzo work on jobs, all scratch coat used for Mosaic and Terrazzo work and sub-bed, tar paper and wire mesh (2x2 etc.) or lath. The rubbing, grinding, cleaning and finishing of same either by hand or by machine or by terrazzo resurfacing equipment on new or existing floors. When necessary finishers shall be allowed to assist the mechanics to spread sand bed, lay tarpaper and wire mesh (2x2 etc.) or lath. The finishing of cement floors where additional aggregate of stone is added by spreading or sprinkling on top of the finished base, and troweled or rolled into the finish and then the surface is ground by grinding machines.

Other Classifications of Work:

For definitions of classifications not otherwise set out, the Department generally has on file such definitions which are available.

If a task to be performed is not subject to one of the classifications of pay set out, the Department will upon being contacted state which neighboring county has such a classification and provide such rate, such rate being deemed to exist by reference in this document. If no neighboring county rate applies to the task, the Department shall undertake a special determination, such special determination being then deemed to have existed under this determination. If a project requires these, or any classification not listed, please contact IDOL at 217-782-1710 for wage rates or clarifications.

LANDSCAPING

Landscaping work falls under the existing classifications for laborer, operating engineer and truck driver. The work performed by landscape plantsman and landscape laborer is covered by the existing classification of laborer. The work performed by landscape operators (regardless of equipment used or its size) is covered by the classifications of operating engineer. The work performed by landscape truck drivers (regardless of size of truck driven) is covered by the classifications of truck driver.

Washington County Prevailing Wage for May 2012

(See explanation of column headings at bottom of wages)

| Trade Name | RG | TYP | C | Base | FRMAN | *M-F>8 | OSA | OSH | H/W | Pensn | Vac | Trng |
|----------------------|----|-----|---|--------|--------|--------|-----|-----|-------|-------|-------|-------|
| ===== | == | === | = | ===== | ===== | ===== | === | === | ===== | ===== | ===== | ===== |
| ASBESTOS ABT-GEN | | ALL | | 26.810 | 27.310 | 1.5 | 1.5 | 2.0 | 5.550 | 12.34 | 0.000 | 0.800 |
| ASBESTOS ABT-MEC | | BLD | | 29.160 | 30.160 | 1.5 | 1.5 | 2.0 | 6.700 | 2.750 | 0.000 | 0.000 |
| BOILERMAKER | | BLD | | 31.500 | 34.000 | 1.5 | 1.5 | 2.0 | 7.070 | 18.73 | 1.000 | 0.350 |
| BRICK MASON | | BLD | | 28.790 | 30.640 | 1.5 | 1.5 | 2.0 | 7.500 | 9.430 | 2.000 | 0.400 |
| CARPENTER | | ALL | | 33.880 | 35.380 | 1.5 | 1.5 | 2.0 | 6.300 | 6.250 | 0.000 | 0.400 |
| CEMENT MASON | | BLD | | 28.200 | 29.700 | 1.5 | 1.5 | 2.0 | 6.600 | 5.400 | 0.000 | 0.500 |
| CEMENT MASON | | HWY | | 33.100 | 33.600 | 1.5 | 1.5 | 2.0 | 6.400 | 9.750 | 0.000 | 0.700 |
| CERAMIC TILE FNSHER | | BLD | | 25.520 | 0.000 | 1.5 | 1.5 | 2.0 | 5.900 | 5.110 | 0.000 | 0.470 |
| ELECTRIC PWR EQMT OP | | ALL | | 34.800 | 0.000 | 1.5 | 2.0 | 2.0 | 5.850 | 9.750 | 0.000 | 0.260 |
| ELECTRIC PWR GRNDMAN | | ALL | | 25.980 | 0.000 | 1.5 | 2.0 | 2.0 | 4.370 | 7.280 | 0.000 | 0.190 |
| ELECTRIC PWR LINEMAN | | ALL | | 40.020 | 41.950 | 1.5 | 1.5 | 2.0 | 6.720 | 11.21 | 0.000 | 0.300 |
| ELECTRIC PWR TRK DRV | | ALL | | 28.410 | 0.000 | 1.5 | 2.0 | 2.0 | 4.780 | 7.950 | 0.000 | 0.210 |
| ELECTRICIAN | NW | ALL | | 36.510 | 38.700 | 1.5 | 1.5 | 2.0 | 7.210 | 7.490 | 0.000 | 0.640 |
| ELECTRICIAN | SE | ALL | | 37.930 | 40.180 | 1.5 | 1.5 | 2.0 | 5.350 | 9.110 | 0.000 | 0.760 |
| ELECTRONIC SYS TECH | | BLD | | 31.870 | 33.620 | 1.5 | 1.5 | 2.0 | 5.350 | 4.150 | 0.000 | 0.400 |
| ELEVATOR CONSTRUCTOR | | BLD | | 43.345 | 48.760 | 2.0 | 2.0 | 2.0 | 11.03 | 11.96 | 2.600 | 0.000 |
| FLOOR LAYER | | BLD | | 29.080 | 29.830 | 1.5 | 1.5 | 2.0 | 6.300 | 6.250 | 0.000 | 0.400 |
| GLAZIER | | BLD | | 32.780 | 0.000 | 2.0 | 2.0 | 2.0 | 9.020 | 10.80 | 2.630 | 0.310 |
| HT/FROST INSULATOR | | BLD | | 36.760 | 37.760 | 1.5 | 1.5 | 2.0 | 7.550 | 10.76 | 0.000 | 0.500 |
| IRON WORKER | | ALL | | 31.000 | 33.000 | 1.5 | 1.5 | 2.0 | 7.110 | 12.35 | 0.000 | 0.420 |
| LABORER | | ALL | | 26.310 | 26.810 | 1.5 | 1.5 | 2.0 | 5.550 | 12.34 | 0.000 | 0.800 |
| MACHINIST | | BLD | | 43.160 | 45.160 | 1.5 | 1.5 | 2.0 | 7.980 | 8.950 | 0.000 | 0.000 |
| MARBLE FINISHERS | | BLD | | 25.520 | 0.000 | 1.5 | 1.5 | 2.0 | 5.900 | 5.110 | 0.000 | 0.470 |
| MARBLE MASON | | BLD | | 28.790 | 30.640 | 1.5 | 1.5 | 2.0 | 7.500 | 9.430 | 2.000 | 0.400 |
| MILLWRIGHT | | ALL | | 33.880 | 35.380 | 1.5 | 1.5 | 2.0 | 6.300 | 6.250 | 0.000 | 0.400 |
| OPERATING ENGINEER | | BLD | 1 | 33.650 | 36.650 | 1.5 | 1.5 | 2.0 | 8.400 | 16.50 | 0.000 | 1.000 |
| OPERATING ENGINEER | | BLD | 2 | 32.520 | 36.650 | 1.5 | 1.5 | 2.0 | 8.400 | 16.50 | 0.000 | 1.000 |
| OPERATING ENGINEER | | BLD | 3 | 28.040 | 36.650 | 1.5 | 1.5 | 2.0 | 8.400 | 16.50 | 0.000 | 1.000 |
| OPERATING ENGINEER | | BLD | 4 | 28.100 | 36.650 | 1.5 | 1.5 | 2.0 | 8.400 | 16.50 | 0.000 | 1.000 |
| OPERATING ENGINEER | | BLD | 5 | 27.770 | 36.650 | 1.5 | 1.5 | 2.0 | 8.400 | 16.50 | 0.000 | 1.000 |
| OPERATING ENGINEER | | BLD | 6 | 34.200 | 36.650 | 1.5 | 1.5 | 2.0 | 8.400 | 16.50 | 0.000 | 1.000 |
| OPERATING ENGINEER | | BLD | 7 | 34.500 | 36.650 | 1.5 | 1.5 | 2.0 | 8.400 | 16.50 | 0.000 | 1.000 |
| OPERATING ENGINEER | | BLD | 8 | 34.780 | 36.650 | 1.5 | 1.5 | 2.0 | 8.400 | 16.50 | 0.000 | 1.000 |
| OPERATING ENGINEER | | BLD | 9 | 35.650 | 36.650 | 1.5 | 1.5 | 2.0 | 8.400 | 16.50 | 0.000 | 1.000 |
| OPERATING ENGINEER | | HWY | 1 | 32.150 | 35.150 | 1.5 | 1.5 | 2.0 | 8.400 | 16.50 | 0.000 | 1.000 |
| OPERATING ENGINEER | | HWY | 2 | 31.020 | 35.150 | 1.5 | 1.5 | 2.0 | 8.400 | 16.50 | 0.000 | 1.000 |
| OPERATING ENGINEER | | HWY | 3 | 26.540 | 35.150 | 1.5 | 1.5 | 2.0 | 8.400 | 16.50 | 0.000 | 1.000 |
| OPERATING ENGINEER | | HWY | 4 | 26.600 | 35.150 | 1.5 | 1.5 | 2.0 | 8.400 | 16.50 | 0.000 | 1.000 |
| OPERATING ENGINEER | | HWY | 5 | 26.270 | 35.150 | 1.5 | 1.5 | 2.0 | 8.400 | 16.50 | 0.000 | 1.000 |
| OPERATING ENGINEER | | HWY | 6 | 32.700 | 35.150 | 1.5 | 1.5 | 2.0 | 8.400 | 16.50 | 0.000 | 1.000 |
| OPERATING ENGINEER | | HWY | 7 | 33.000 | 35.150 | 1.5 | 1.5 | 2.0 | 8.400 | 16.50 | 0.000 | 1.000 |
| OPERATING ENGINEER | | HWY | 8 | 33.280 | 35.150 | 1.5 | 1.5 | 2.0 | 8.400 | 16.50 | 0.000 | 1.000 |
| OPERATING ENGINEER | | HWY | 9 | 34.150 | 35.150 | 1.5 | 1.5 | 2.0 | 8.400 | 16.50 | 0.000 | 1.000 |
| PAINTER | | BLD | | 29.250 | 30.750 | 1.5 | 1.5 | 2.0 | 5.000 | 7.920 | 0.000 | 0.600 |
| PAINTER | | HWY | | 30.450 | 31.950 | 1.5 | 1.5 | 2.0 | 5.000 | 7.920 | 0.000 | 0.600 |
| PAINTER OVER 30FT | | BLD | | 30.250 | 31.750 | 1.5 | 1.5 | 2.0 | 5.000 | 7.920 | 0.000 | 0.600 |
| PAINTER PWR EQMT | | BLD | | 30.250 | 31.750 | 1.5 | 1.5 | 2.0 | 5.000 | 7.920 | 0.000 | 0.600 |
| PAINTER PWR EQMT | | HWY | | 31.450 | 32.950 | 1.5 | 1.5 | 2.0 | 5.000 | 7.920 | 0.000 | 0.600 |
| PILEDRIVER | | ALL | | 33.880 | 35.380 | 1.5 | 1.5 | 2.0 | 6.300 | 6.250 | 0.000 | 0.400 |
| PIPEFITTER | E | BLD | | 33.250 | 36.580 | 1.5 | 1.5 | 2.0 | 5.950 | 6.350 | 0.000 | 0.900 |
| PIPEFITTER | W | BLD | | 35.350 | 37.850 | 1.5 | 1.5 | 2.0 | 7.500 | 5.400 | 0.000 | 0.575 |
| PLASTERER | | BLD | | 27.250 | 28.750 | 1.5 | 1.5 | 2.0 | 6.400 | 5.400 | 0.000 | 0.500 |
| PLUMBER | E | BLD | | 33.250 | 36.580 | 1.5 | 1.5 | 2.0 | 5.950 | 6.350 | 0.000 | 0.900 |
| PLUMBER | W | BLD | | 35.350 | 37.850 | 1.5 | 1.5 | 2.0 | 7.500 | 5.400 | 0.000 | 0.575 |
| ROOFER | | BLD | | 28.650 | 30.650 | 1.5 | 1.5 | 2.0 | 8.150 | 6.650 | 0.000 | 0.200 |
| SHEETMETAL WORKER | | ALL | | 31.690 | 33.190 | 1.5 | 1.5 | 2.0 | 7.130 | 6.730 | 1.910 | 0.360 |
| SPRINKLER FITTER | | BLD | | 37.830 | 40.830 | 2.0 | 2.0 | 2.0 | 8.550 | 10.35 | 0.000 | 0.850 |

| | | | | | | | | | | |
|-------------------|-------|--------|--------|-----|-----|-----|-------|-------|-------|-------|
| TERRAZZO FINISHER | BLD | 31.240 | 0.000 | 1.5 | 1.5 | 2.0 | 5.900 | 2.730 | 0.000 | 0.130 |
| TERRAZZO MASON | BLD | 32.530 | 32.830 | 1.5 | 1.5 | 2.0 | 5.900 | 4.980 | 0.000 | 0.140 |
| TRUCK DRIVER | ALL 1 | 30.460 | 0.000 | 1.5 | 1.5 | 2.0 | 10.05 | 4.775 | 0.000 | 0.250 |
| TRUCK DRIVER | ALL 2 | 30.890 | 0.000 | 1.5 | 1.5 | 2.0 | 10.05 | 4.775 | 0.000 | 0.250 |
| TRUCK DRIVER | ALL 3 | 31.120 | 0.000 | 1.5 | 1.5 | 2.0 | 10.05 | 4.775 | 0.000 | 0.250 |
| TRUCK DRIVER | ALL 4 | 31.380 | 0.000 | 1.5 | 1.5 | 2.0 | 10.05 | 4.775 | 0.000 | 0.250 |
| TRUCK DRIVER | ALL 5 | 32.200 | 0.000 | 1.5 | 1.5 | 2.0 | 10.05 | 4.775 | 0.000 | 0.250 |
| TRUCK DRIVER | O&C 1 | 24.370 | 0.000 | 1.5 | 1.5 | 2.0 | 10.05 | 4.775 | 0.000 | 0.250 |
| TRUCK DRIVER | O&C 2 | 24.710 | 0.000 | 1.5 | 1.5 | 2.0 | 10.05 | 4.775 | 0.000 | 0.250 |
| TRUCK DRIVER | O&C 3 | 24.900 | 0.000 | 1.5 | 1.5 | 2.0 | 10.05 | 4.775 | 0.000 | 0.250 |
| TRUCK DRIVER | O&C 4 | 25.100 | 0.000 | 1.5 | 1.5 | 2.0 | 10.05 | 4.775 | 0.000 | 0.250 |
| TRUCK DRIVER | O&C 5 | 25.760 | 0.000 | 1.5 | 1.5 | 2.0 | 10.05 | 4.775 | 0.000 | 0.250 |

Legend:

RG (Region)

TYP (Trade Type - All,Highway,Building,Floating,Oil & Chip,Rivers)

C (Class)

Base (Base Wage Rate)

FRMAN (Foreman Rate)

M-F>8 (OT required for any hour greater than 8 worked each day, Mon through Fri.)

OSA (Overtime (OT) is required for every hour worked on Saturday)

OSH (Overtime is required for every hour worked on Sunday and Holidays)

H/W (Health & Welfare Insurance)

Pensn (Pension)

Vac (Vacation)

Trng (Training)

Explanations

WASHINGTON COUNTY

ELECTRICIANS (NORTHWEST) - Township of Venedy.

PLUMBERS & PIPEFITTERS (WEST) - That part of the county West of a line 2.5 miles East of Rt. 127 including the towns of Posin, Beacoup and New Minden.

PLUMBERS & PIPEFITTERS (EAST) - That part of the county East of a North-South line 2.5 miles East of Rt. 127.

The following list is considered as those days for which holiday rates of wages for work performed apply: New Years Day, Memorial Day, Fourth of July, Labor Day, Thanksgiving Day, Christmas Day and Veterans Day in some classifications/counties. Generally, any of these holidays which fall on a Sunday is celebrated on the following Monday. This then makes work performed on that Monday payable at the appropriate overtime rate for holiday pay. Common practice in a given local may alter certain days of celebration. If in doubt, please check with IDOL.

Oil and chip resealing (O&C) means the application of road oils and liquid asphalt to coat an existing road surface, followed by application of aggregate chips or gravel to coated surface, and subsequent rolling of material to seal the surface.

EXPLANATION OF CLASSES

ASBESTOS - GENERAL - removal of asbestos material/mold and hazardous materials from any place in a building, including mechanical systems where those mechanical systems are to be removed. This includes the removal of asbestos materials/mold and hazardous materials from ductwork or pipes in a building when the building is to be demolished at the time or at some close future date.

ASBESTOS - MECHANICAL - removal of asbestos material from mechanical systems, such as pipes, ducts, and boilers, where the mechanical systems are to remain.

CERAMIC TILE FINISHER AND MARBLE FINISHER

The handling, at the building site, of all sand, cement, tile, marble or stone and all other materials that may be used and installed by [a] tile layer or marble mason. In addition, the grouting, cleaning, sealing, and mixing on the job site, and all other work as required in assisting the setter. The term "Ceramic" is used for naming the classification only and is in no way a limitation of the product handled. Ceramic takes into consideration most hard tiles.

ELECTRONIC SYSTEMS TECHNICIAN

Installation, service and maintenance of low-voltage systems which utilizes the transmission and/or transference of voice, sound, vision, or digital for commercial, education, security and entertainment purposes for the following: TV monitoring and surveillance, background/foreground music, intercom and telephone interconnect, field programming, inventory control systems, microwave transmission, multi-media, multiplex, radio page, school, intercom and sound burglar alarms and low voltage master clock systems.

Excluded from this classification are energy management systems, life safety systems, supervisory controls and data acquisition systems not intrinsic with the above listed systems, fire alarm systems, nurse call systems and raceways exceeding fifteen feet in length.

OPERATING ENGINEER - BUILDING

GROUP I. Cranes, Dragline, Shovels, Skimmer Scoops, Clamshells or Derrick Boats, Pile Drivers, Crane-Type Backhoes, Asphalt Plant Operators, Concrete Plant Operators, Dredges, Asphalt Spreading Machines, All Locomotives, Cable Ways or Tower Machines, Hoists, Hydraulic Backhoes, Ditching Machines or Backfiller, Cherrypickers, Overhead Cranes, Roller - Steam or Gas, Concrete Pavers, Excavators, Concrete Breakers, Concrete Pumps, Bulk Cement Plants, Cement Pumps,

Derrick-Type Drills, Boat Operators, Motor Graders or Pushcats, Scoops or Tournapulls, Bulldozers, Endloaders or Fork Lifts, Power Blade or Elevating Graders, Winch Cats, Boom or Winch Trucks or Boom Tractors, Pipe Wrapping or Painting Machines, Asphalt Plant Engineer, Journeyman Lubricating Engineer, Drills (other than Derrick Type), Mud Jacks, or Well Drilling Machines, Boring Machines or Track Jacks, Mixers, Conveyors (Two), Air Compressors (Two), Water Pumps regardless of size (Two), Welding Machines (Two), Siphons or Jets (Two), Winch Heads or Apparatuses (Two), Light Plants (Two), All Tractors regardless of size (straight tractor only), Fireman on Stationary Boilers, Automatic Elevators, Form Grading Machines, Finishing Machines, Power Sub-Grader or Ribbon Machines, Longitudinal Floats, Distributor Operators on Trucks, Winch Heads or Apparatuses (One), Mobil Track air and heaters (two to five), Heavy Equipment Greaser, Relief Operator, Assistant Master Mechanic and Heavy Duty Mechanic, self-propelled concrete saws of all types and sizes with their attachments, gob-hoppers, excavators all sizes, the repair and greasing of all diesel hammers, the operation and set-up of bidwells, water blasters of all sizes and their clutches, hydraulic jacks where used for hoisting, operation of log skidders, iceolators used on and off of pipeline, condor cranes, bow boats, survey boats, bobcats and all their attachments, skid steer loaders and all their attachments, creter cranes, batch plants, operator (all sizes), self propelled roto mills, operation of conveyor systems of any size and any configuration, operation, repair and service of all vibratory hammers, all power pacs and their controls regardless of location, curtains or brush burning machines, stump cutter machines, Nail launchers when mounted on a machine or self-propelled, operation of con-cover machines, and all Operators except those listed below).

GROUP II. Assistant Operators.

GROUP III. Air Compressors (One), Water Pumps, regardless of Size (One), Waterblasters (one), Welding Machine (One), Mixers (One Bag), Conveyor (One), Siphon or Jet (One), Light Plant (One), Heater (One), Immobile Track Air (One), and Self Propelled Walk-Behind Rollers.

GROUP IV. Asphalt Spreader Oilers, Fireman on Whirlies and Heavy Equipment Oilers, Truck Cranes, Dredges, Monigans, Large Cranes - (Over 65-ton rated capacity) Concrete Plant Oiler, Blacktop Plant Oiler, and Creter Crane Oiler (when required).

GROUP V. Oiler.

GROUP VI. Operators on equipment with Booms, including jibs, 100 feet and over, and less than 150 feet long.

GROUP VII. Operators on equipment with Booms, including jibs, 150 feet and over, and less than 200 feet long.

GROUP VIII. Operators on Equipment with Booms, including jibs, 200 feet and over; Tower Cranes; and Whirlie Cranes.

GROUP IX. Master Mechanic

OPERATING ENGINEERS - Highway

GROUP I. Cranes, Dragline, Shovels, Skimmer Scoops, Clamshells or Derrick Boats, Pile Drivers, Crane-Type Backhoes, Asphalt Plant Operators, Concrete Plant Operators, Dredges, Asphalt Spreading Machines, All Locomotives, Cable Ways or Tower Machines, Hoists, Hydraulic Backhoes, Ditching Machines or Backfiller, Cherrypickers, Overhead Cranes, Roller - Steam or Gas, Concrete Pavers, Excavators,

Concrete Breakers, Concrete Pumps, Bulk Cement Plants, Cement Pumps, Derrick-Type Drills, Boat Operators, Motor Graders or Pushcats, Scoops or Tournapulls, Bulldozers, Endloaders or Fork Lifts, Power Blade or Elevating Graders, Winch Cats, Boom or Winch Trucks or Boom Tractors, Pipe Wrapping or Painting Machines, Asphalt Plant Engineer, Journeyman Lubricating Engineer, Drills (other than Derrick Type), Mud Jacks, Well Drilling Machines, Boring Machines, Track Jacks, Mixers, Conveyors (Two), Air Compressors (Two), Water Pumps regardless of size (Two), Welding Machines (Two), Siphons or Jets (Two), Winch Heads or Apparatuses (Two), Light Plants (Two), All Tractors regardless of size (straight tractor only), Fireman on Stationary Boilers, Automatic Elevators, Form Grading Machines, Finishing Machines, Power Sub-Grader or Ribbon Machines, Longitudinal Floats, Distributor Operators on Trucks, Winch Heads or Apparatuses (One), Mobil Track air and heaters (two to five), Heavy Equipment Greaser, Relief Operator, Assistant Master Mechanic and Heavy Duty Mechanic, self-propelled concrete saws of all types and sizes with their attachments, gob-hoppers, excavators all sizes, the repair and greasing of all diesel hammers, the operation and set-up of bidwells, water blasters of all sizes and their clutches, hydraulic jacks where used for hoisting, operation of log skidders, iceolators used on and off of pipeline, condor cranes, bow boats, survey boats, bobcats and all their attachments, skid steer loaders and all their attachments, creter cranes, batch plants, operator (all sizes), self propelled roto mills, operation of conveyor systems of any size and any configuration, operation, repair and service of all vibratory hammers, all power pacs and their controls regardless of location, curtains or brush burning machines, stump cutter machines, Nail launchers when mounted on a machine or self-propelled, operation of con-cover machines, and all Operators (except those listed below).

GROUP II. Assistant Operators.

GROUP III. Air Compressors (One), Water Pumps, regardless of Size (One), Waterblasters (one), Welding Machine (One), Mixers (One Bag), Conveyor (One), Siphon or Jet (One), Light Plant (One), Heater (One), Immobile Track Air (One), and Self Propelled Walk-Behind Rollers.

GROUP IV. Asphalt Spreader Oilers, Fireman on Whirlies and Heavy Equipment Oilers, Truck Cranes, Dredges, Monigans, Large Cranes - (Over 65-ton rated capacity) Concrete Plant Oiler, Blacktop Plant Oiler, and Creter Crane Oiler (when required).

GROUP V. Oiler.

GROUP VI. Operators on equipment with Booms, including jibs, 100 feet and over, and less than 150 feet long.

GROUP VII. Operators on equipment with Booms, including jibs, 150 feet and over, and less than 200 feet long.

GROUP VIII. Operators on Equipment with Booms, including jibs, 200 feet and over; Tower Cranes; and Whirlie Cranes.

GROUP IX. Mechanic

TRUCK DRIVER - BUILDING, HEAVY AND HIGHWAY CONSTRUCTION

Class 1. Drivers on 2 axle trucks hauling less than 9 ton. Air compressor and welding machines and brooms, including those pulled by separate units, truck driver helpers, warehouse employees, mechanic helpers, greasers and tiremen, pickup trucks when hauling materials,

tools, or workers to and from and on-the-job site, and fork lifts up to 6,000 lb. capacity.

Class 2. Two or three axle trucks hauling more than 9 ton but hauling less than 16 ton. A-frame winch trucks, hydrolift trucks, vactor trucks or similar equipment when used for transportation purposes. Fork lifts over 6,000 lb. capacity, winch trucks, four axle combination units, and ticket writers.

Class 3. Two, three or four axle trucks hauling 16 ton or more. Drivers on water pulls, articulated dump trucks, mechanics and working forepersons, and dispatchers. Five axle or more combination units.

Class 4. Low Boy and Oil Distributors.

Class 5. Drivers who require special protective clothing while employed on hazardous waste work. Jurisdiction in Bond, Calhoun, Clinton, Fayette, Greene, Jefferson, Jersey, Macoupin, Madison, Marion, Monroe, Montgomery, Perry, Randolph, St. Clair, and Washington.

TRUCK DRIVER - OIL AND CHIP RESEALING ONLY.

This shall encompass laborers, workers and mechanics who drive contractor or subcontractor owned, leased, or hired pickup, dump, service, or oil distributor trucks. The work includes transporting materials and equipment (including but not limited to, oils, aggregate supplies, parts, machinery and tools) to or from the job site; distributing oil or liquid asphalt and aggregate; stock piling material when in connection with the actual oil and chip contract. The Truck Driver (Oil & Chip Resealing) wage classification does not include supplier delivered materials.

TERRAZZO FINISHER

The handling of all materials used for Mosaic and Terrazzo work including preparing, mixing by hand, by mixing machine or transporting of pre-mixed materials and distributing with shovel, rake, hoe, or pail, all kinds of concrete foundations necessary for Mosaic and Terrazzo work, all cement terrazzo, magnesite terrazzo, Do-O-Tex terrazzo, epoxy matrix ter-razzo, exposed aggregate, rustic or rough washed for exterior or interior of buildings placed either by machine or by hand, and any other kind of mixture of plastics composed of chips or granules when mixed with cement, rubber, neoprene, vinyl, magnesium chloride or any other resinous or chemical substances used for seamless flooring systems, and all other building materials, all similar materials and all precast terrazzo work on jobs, all scratch coat used for Mosaic and Terrazzo work and sub-bed, tar paper and wire mesh (2x2 etc.) or lath. The rubbing, grinding, cleaning and finishing of same either by hand or by machine or by terrazzo resurfacing equipment on new or existing floors. When necessary finishers shall be allowed to assist the mechanics to spread sand bed, lay tarpaper and wire mesh (2x2 etc.) or lath. The finishing of cement floors where additional aggregate of stone is added by spreading or sprinkling on top of the finished base, and troweled or rolled into the finish and then the surface is ground by grinding machines.

Other Classifications of Work:

For definitions of classifications not otherwise set out, the

Department generally has on file such definitions which are available. If a task to be performed is not subject to one of the classifications of pay set out, the Department will upon being contacted state which neighboring county has such a classification and provide such rate, such rate being deemed to exist by reference in this document. If no neighboring county rate applies to the task, the Department shall undertake a special determination, such special determination being then deemed to have existed under this determination. If a project requires these, or any classification not listed, please contact IDOL at 217-782-1710 for wage rates or clarifications.

LANDSCAPING

Landscaping work falls under the existing classifications for laborer, operating engineer and truck driver. The work performed by landscape plantsman and landscape laborer is covered by the existing classification of laborer. The work performed by landscape operators (regardless of equipment used or its size) is covered by the classifications of operating engineer. The work performed by landscape truck drivers (regardless of size of truck driven) is covered by the classifications of truck driver.