

ROUTE	SECTION	COUNTY	TOTAL SHEETS	SHEET NUMBER
VARIOUS	2011-059-I	COOK	44	10

Contract 60P77

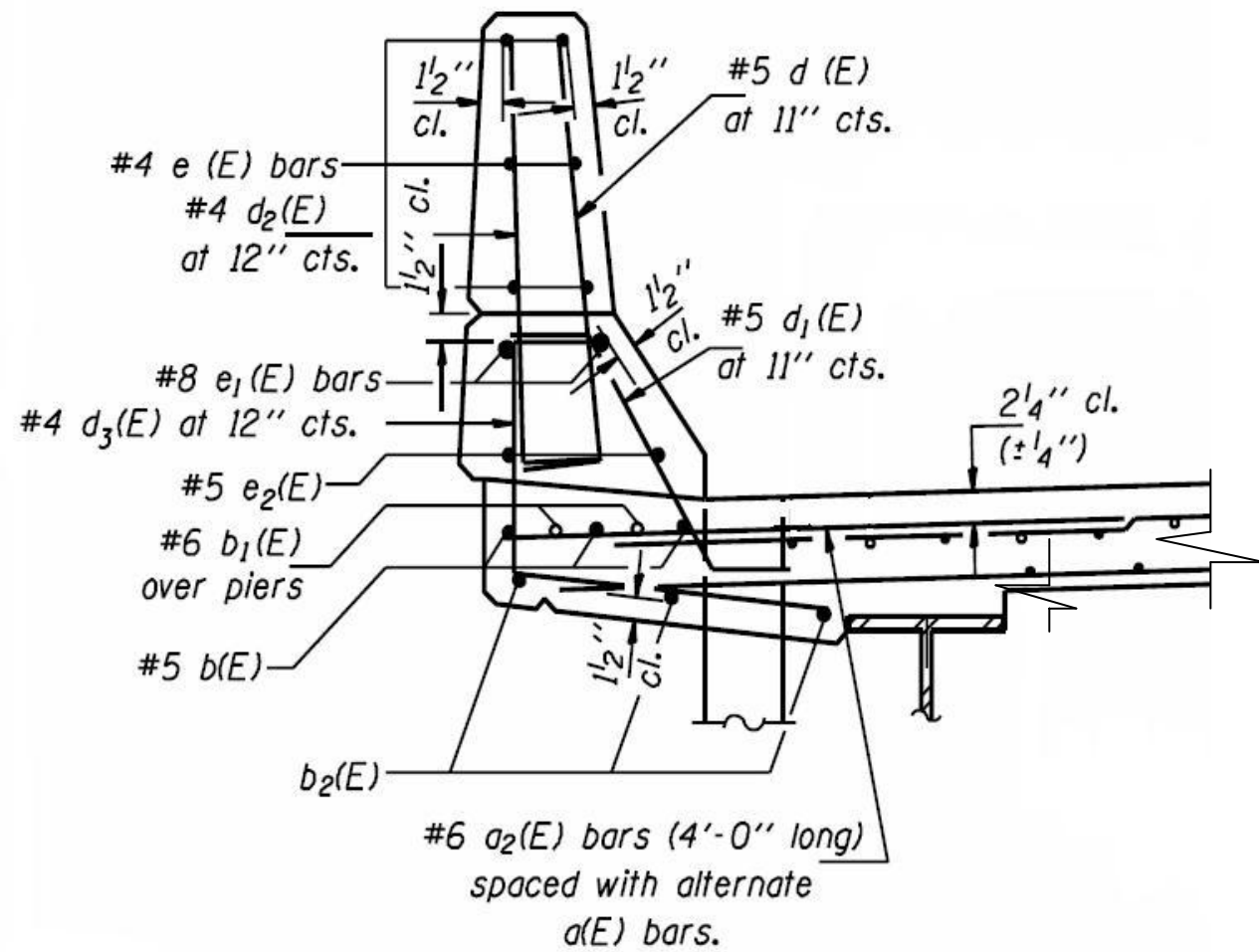

SECTION THRU PARAPET

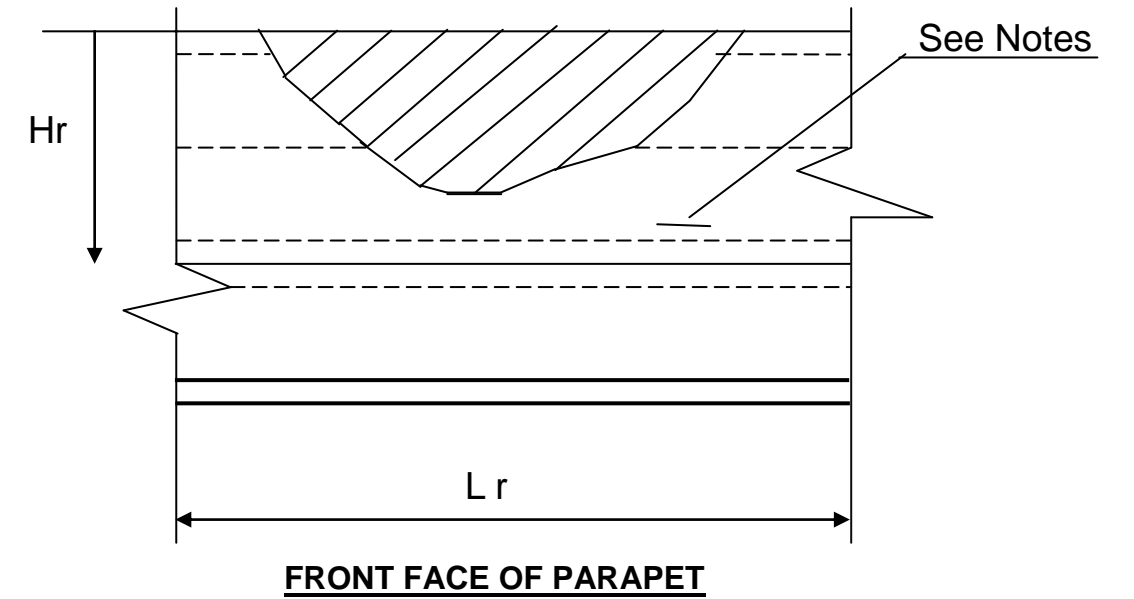

FRONT FACE OF PARAPET

Hr and Lr indicate dimensions for concrete removal. Perimeters of concrete removal areas shall be saw cut $\frac{3}{4}$ " prior to removal of concrete.

NOTES:

Concrete removal shall extend a minimum of 6" past damage or to joint if within 2'-0".

Existing bars to be cleaned, straightened and incorporated in new construction.

If existing vertical rebar is missing, bars d(E) and d2(E) shall be straightened and epoxy grouted into existing concrete 9" deep. Cost shall be included in "Concrete Removal"

Bars to be epoxy grouted according to Art.584 of the Standard Specifications.

ILLINOIS DEPARTMENT OF TRANSPORTATION

TYPICAL BRIDGE PARAPET
REPAIR DETAILS