

DETAILS OF SURFACING AT INTERSECTIONS AND SIDEROADS

F.A.S.	SECTION	COUNTY	TOTAL SHEETS	SHEET NO.
815	06-00101-00-RS	WHITE	4	3
FED. ROAD DIST. NO. 1		ILLINOIS	GRAYVILLE-BURNT PRAIRIE	
LEC JOB # H051014WH			CONTRACT # 98295	

DETAIL OF TAPER STA. 0+00 TO STA. 0+50
DETAIL OF INTERSECTION 0+25 RT

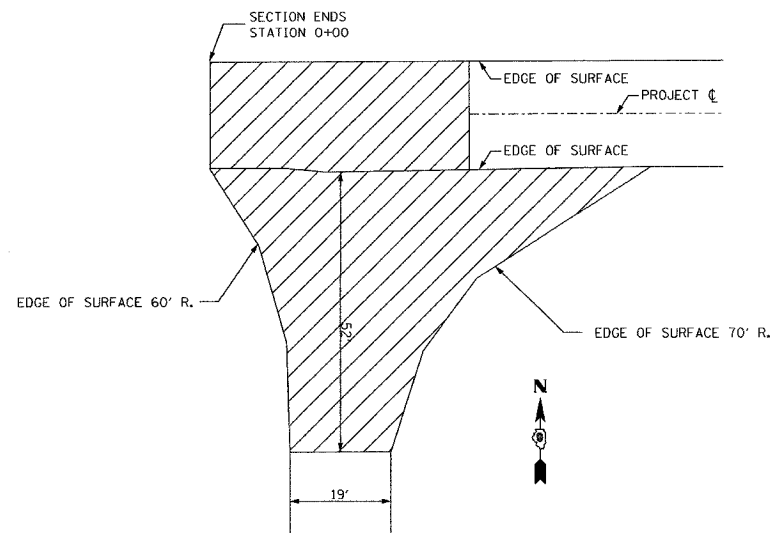

NOTE: THE QUANTITY SHOWN FOR HOT-MIX ASPHALT SURFACE COURSE, MIX "C", N50 INCLUDES 25.7 TONS OF MATERIAL FOR THE TAPER FROM STATION 0+00 TO STATION 0+50. IT ALSO INCLUDES 45.7 TONS OF MATERIAL FOR THE SIDEROAD RT. APPROACH AND RADII.

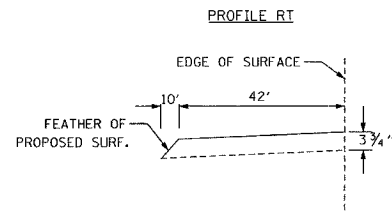
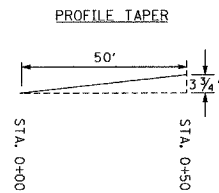

DETAIL OF INTERSECTION RT. STA. 43+33

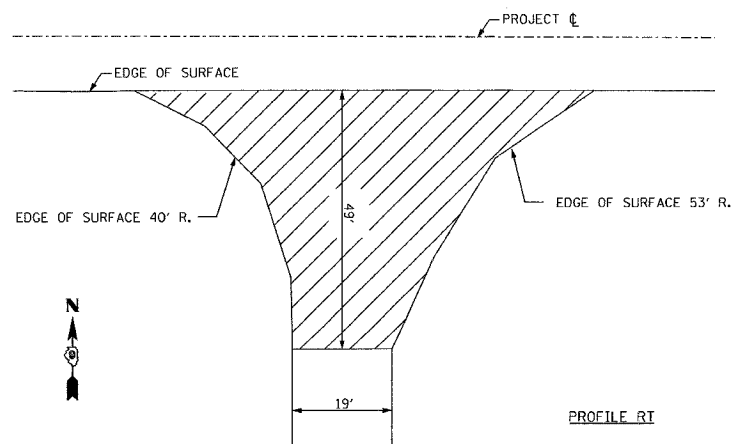

NOTE: THE QUANTITY SHOWN FOR HOT-MIX ASPHALT SURFACE COURSE, MIX "C", N50 INCLUDES 45.2 TONS OF MATERIAL FOR THE SIDEROAD APPROACH AND RADII.

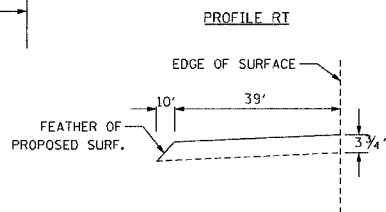

DETAIL OF TAPER STA. 16+50 TO STA. 17+25
& STA. 28+95 TO STA. 29+70

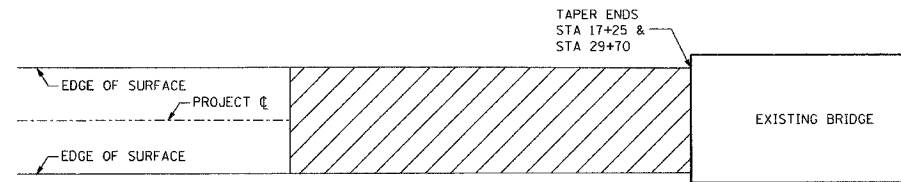

BUTT JOINT DETAIL
STA 16+50 TO STA 17+25 &
STA 28+95 TO STA 29+70

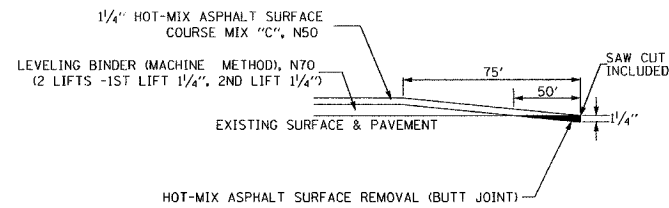

TEMPORARY RAMP DETAIL
STA 16+50 TO STA 17+25 &
STA 28+95 TO STA 29+70

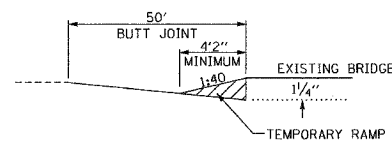

DETAIL OF TAPER STA. 16+50 TO STA. 17+25
& STA. 30+90 TO STA 31+65

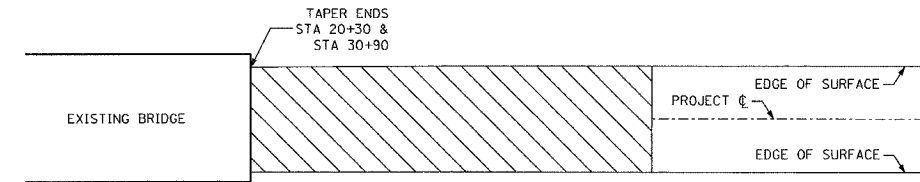

BUTT JOINT DETAIL
STA 20+30 TO STA 21+05
& STA 30+90 TO STA 31+65

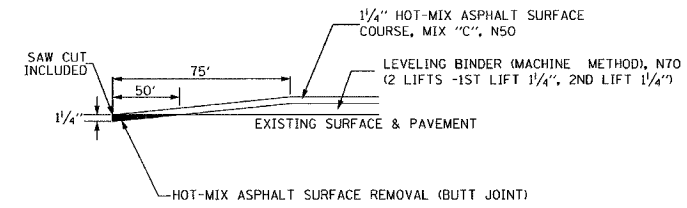

TEMPORARY RAMP DETAIL
STA 20+30 TO STA 21+05
& STA 30+90 TO STA 31+65

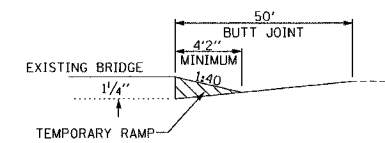

DETAIL OF INTERSECTION LT. STA. A0+27

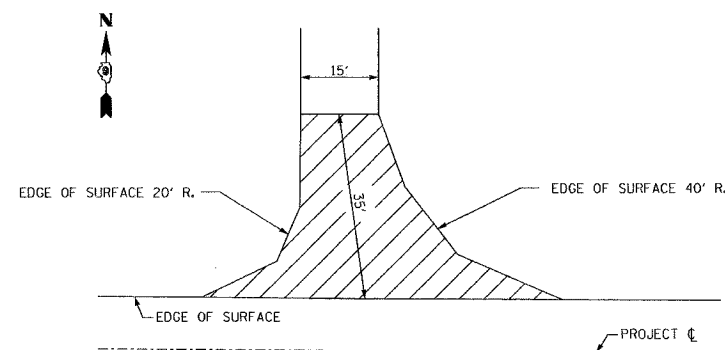

NOTE: THE QUANTITY SHOWN FOR HOT-MIX ASPHALT SURFACE COURSE, MIX "C", N50 INCLUDES 22.9 TONS OF MATERIAL FOR THE SIDEROAD APPROACH AND RADII.

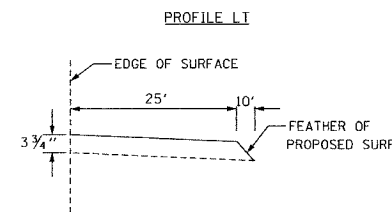

DETAIL OF TAPER STA. A51+50 TO STA. A52+00

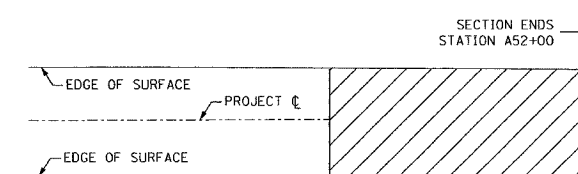

NOTE: THE QUANTITY SHOWN FOR HOT-MIX ASPHALT SURFACE COURSE, MIX "C", N50 INCLUDES 23.3 TONS OF MATERIAL FOR THE TAPER FROM STATION A51+50 TO STATION A52+00.

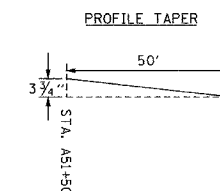

323 W. 3RD ST.
P.O. BOX 160
MT. CARMEL, IL
62863
PHONE:
(618)-262-8651
FAX:
(618)-263-3327

405 W. STATE ST.
SUITE 1
PRINCETON, IN
47670
PHONE:
(312)-386-7611
FAX:
(312)-385-2812



PROFESSIONAL DESIGN FIRM
LAND SURVEY &
PROFESSIONAL
ENGINEERING
CORPORATION
184-000897
(62-032435)(35-002769)

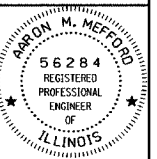

AARON M. MEFFORD
NAME
Aaron M. Mefford
SIGNATURE
3-8-07
DATE
11-30-07
EXPIRES