

STATE OF ILLINOIS
DEPARTMENT OF TRANSPORTATION

ROUTE NO.	SECTION	COUNTY	LETS	SHEET NO.	SHEET NO. 3 14 SHEETS
F.A.P. 693	(119B-3)1	TAZEWELL	33	12	
FED. ROAD DIST. NO. 7	ILLINOIS	FED. AID PROJECT			

Contract #68415

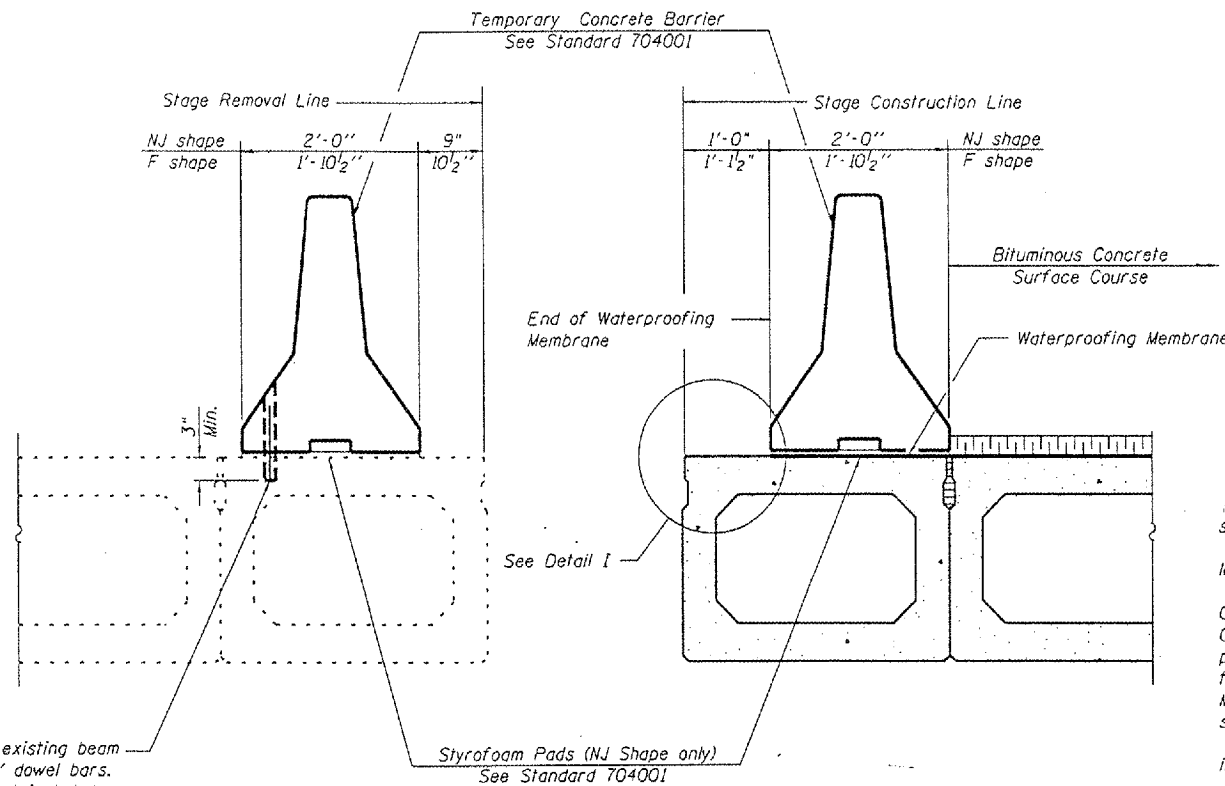

Drill 1/4" ϕ Holes in existing beam
beam for 1" ϕ x 10" dowel bars.
Traffic side only. Cost included
with Temporary Concrete Barrier.

EXISTING PPC DECK BEAMS

NEW PPC DECK BEAMS

SECTIONS THRU PPC DECK BEAMS

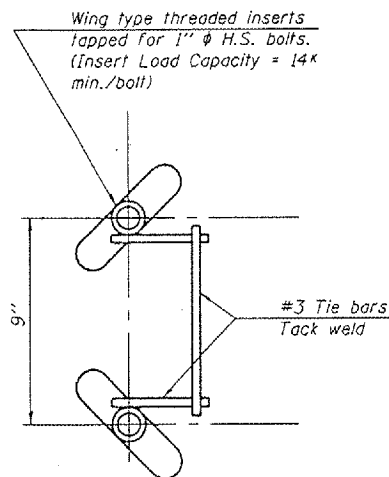

INSERT DETAIL

2 - Wing type threaded
inserts for 1" ϕ H.S. bolts
with flat hardened washer.
Grout holes after removal.

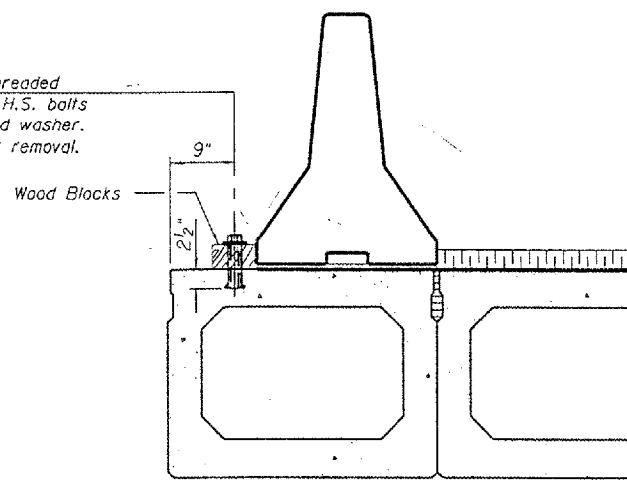

DETAIL I

The Temporary Concrete Barrier and wood blocks
shall not be removed until Stage II Construction
PPC Deck Beams have been placed and shear keys
grouted.

NOTES

The 1" ϕ high strength bolts used to connect the wood blocks
shall be tightened to a snug fit without crushing the wood block.
The wing type threaded insert assembly shall be spaced 5'-0"
longitudinally.
The Waterproofing Membrane shall extend under the Temporary
Concrete Barrier without the asphalt sand seal protection layer.
Once the Temporary Concrete Barrier has been removed, and the
penetrating primer, coal tar emulsion, coal tar emulsion and fiberglass
fabric, and coal tar emulsion slurry layers of the Waterproofing
Membrane is lapped 6", the asphalt sand seal protection layer
shall be applied according to Article 581 of the Standard Specifications.
The cast for H.S. bolts, flat headed washers, and wood block is
included with Temporary Concrete Barrier.
The cast for wing type threaded inserts is included with Precast
Prestressed Concrete Deck Beams (27" Depth).

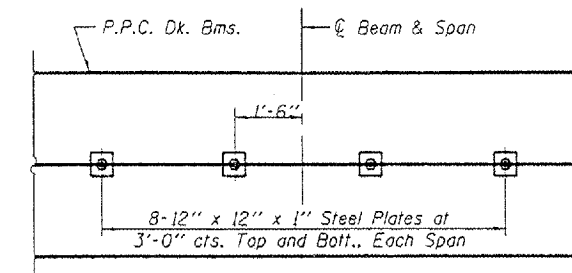

PLAN

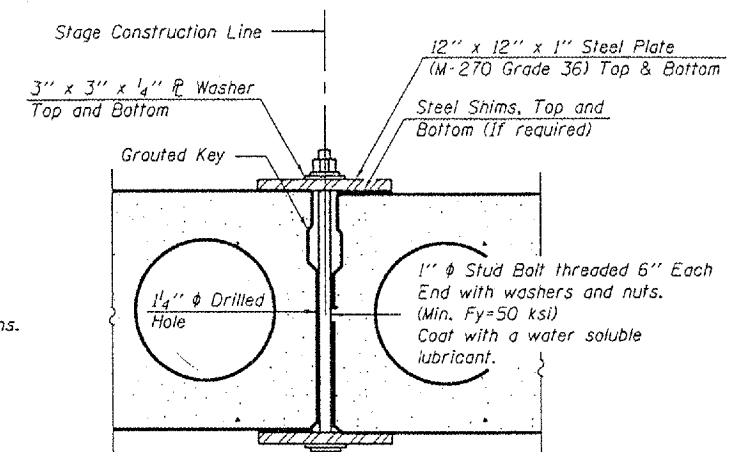

SECTION

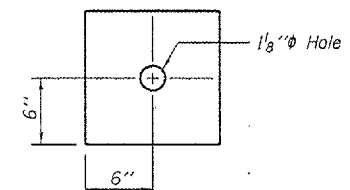

CLAMPING PLATE

SHEAR KEY CLAMPING DETAILS AT STAGE CONST. JT.

See Art. 504.06(d) of the Standard Specifications for Stage
Construction of Precast Prestressed Concrete Deck Beams.
Cost included with Precast Prestressed Concrete
Deck Beams (27" Depth).
See Stage Construction Details for traffic lanes.

TEMPORARY CONCRETE BARRIER AND
STAGE CONSTRUCTION DETAILS
ILLINOIS ROUTE 9 OVER
PRAIRIE CREEK
F.A.P. ROUTE 693 SECTION (119B-3)1
TAZEWELL COUNTY
SN 090-0061

DESIGNED BWP	THOUVENOT, WADE & MOERCHEN, INC.
CHECKED ALN	DIRECTOR • SUPERVISOR • ENGINEER
DRAWN BWP	
CHECKED KPC	COMPANY OFFICE 4940 OLD COLLINGSVILLE RD. SHAMONG, ILLINOIS 62276 TEL. (618) 624-4486 FAX (618) 624-8888 E-MAIL: COWI@TWM-INC.COM