

F.A.S. RTE.	SECTION	COUNTY	TOTAL SHEETS	SHEET NO.
301	•	**	18	16
STA.		TO STA.		
FED. ROAD DIST. NO.		ILLINOIS FED. AID PROJECT		
•113RS-3 & 114RS-2		**GRUNDY & WILL		

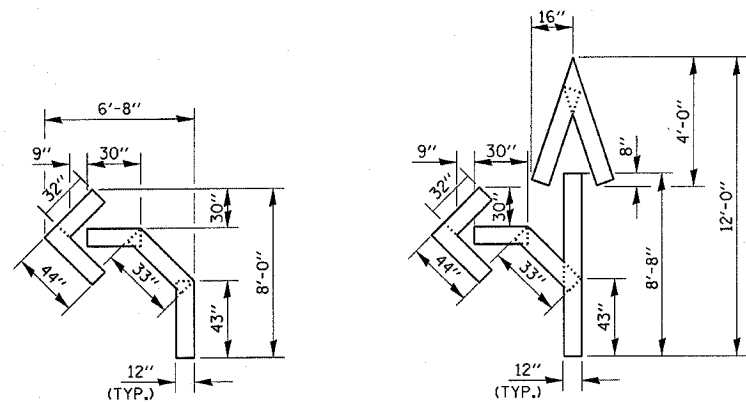

QUANTITY
12" LINE = 16 LIN. FT.
OR 4" LINE = 48 LIN. FT.

QUANTITY
12" LINE = 29 LIN. FT.
OR 4" LINE = 87 LIN. FT.

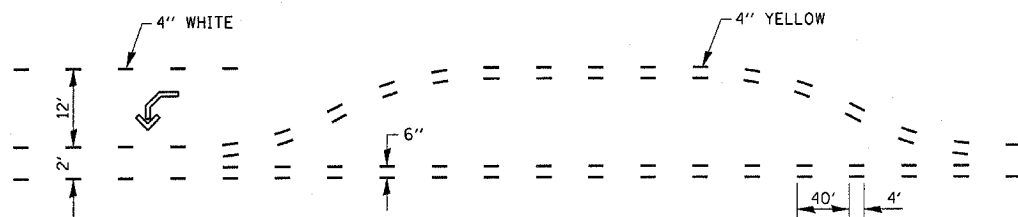

SHORT-TERM PAVEMENT MARKING FOR MEDIANS AND ARROWS

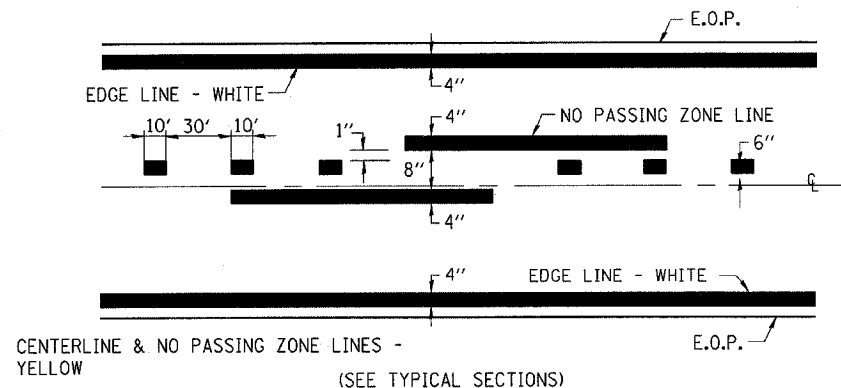

PAVEMENT MARKING

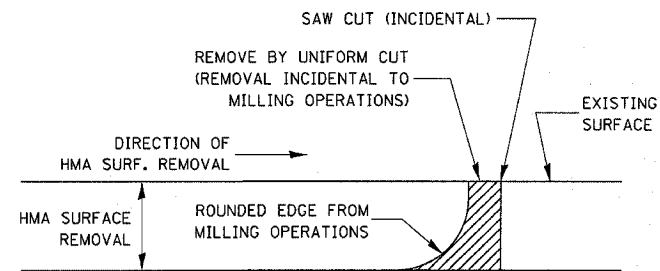

NOTE:
WHEN MILLING OPERATIONS PRODUCE A ROUNDED EDGE, THEN A SAW CUT SHALL BE USED TO MANUFACTURE A PERPENDICULAR EDGE AS SHOWN IN THE DETAIL. THE ENGINEER SHALL BE THE SOLE JUDGE CONCERNING THE USE OF THIS DETAIL

HMA DETAIL AT BUTT JOINTS

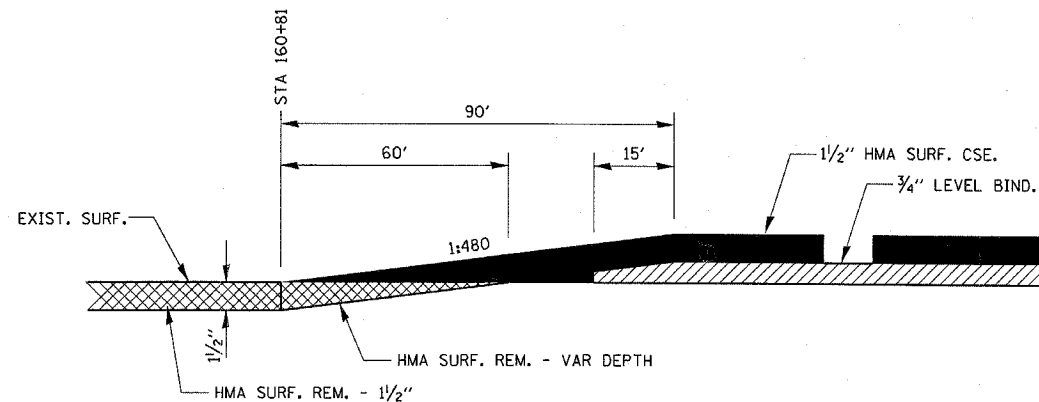

TAPER DETAIL AT MILLING TRANSITION

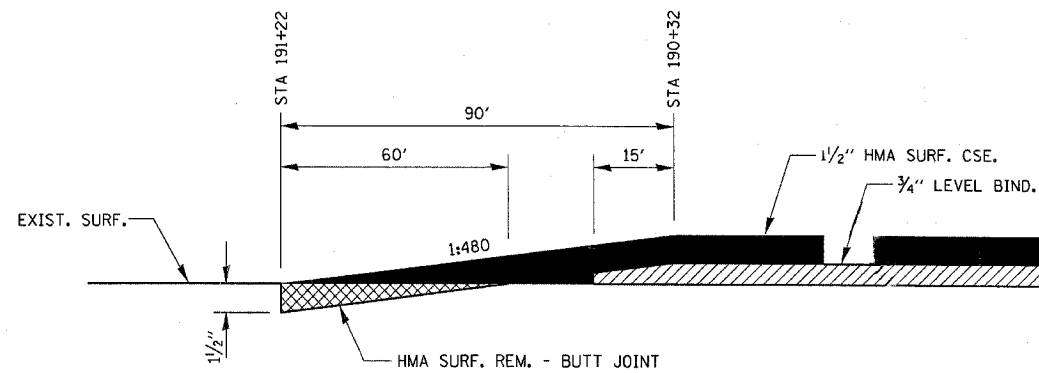

TAPER DETAIL AT END OF PROJECT

REVISIONS	
NAME	DATE

ILLINOIS DEPARTMENT OF TRANSPORTATION

DETAILS

SCALE: VERT. DATE
HORIZ.

DRAWN BY
CHECKED BY