

F.A.P. RTE.	SECTION	COUNTY	TOTAL SHEETS	SHEET NO.
505	110RS-1, 111RS-3	STEPHENSON	174	17
STA.	TO STA.			
FED. ROAD DIST. NO.	ILLINOIS	FED. AID PROJECT		
CONTRACT NO. 64C32				

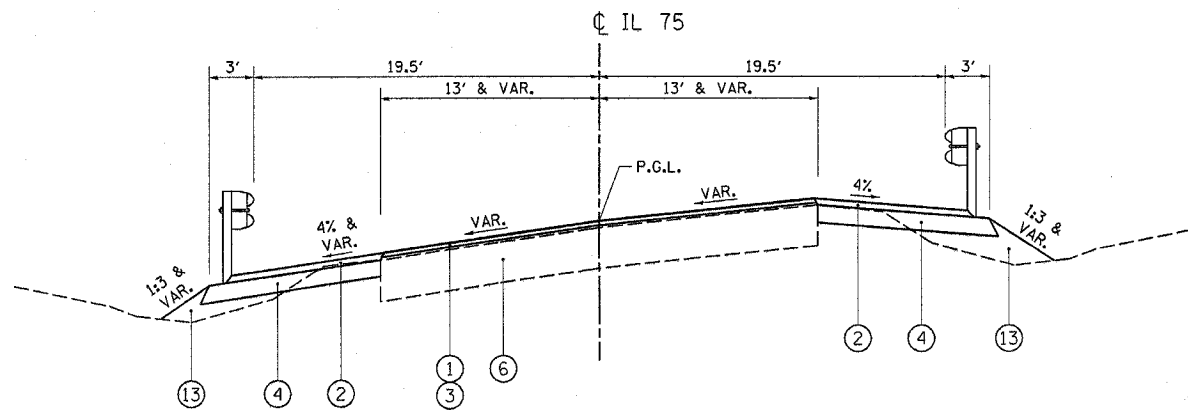

TYPICAL SECTION - RESURFACING SUPERELEVATED LEFT, GUARDRAIL

STA 10237+37 TO 10242+65 (*3/*4)
STA 10447+00 TO 10449+56 (*9/*10)

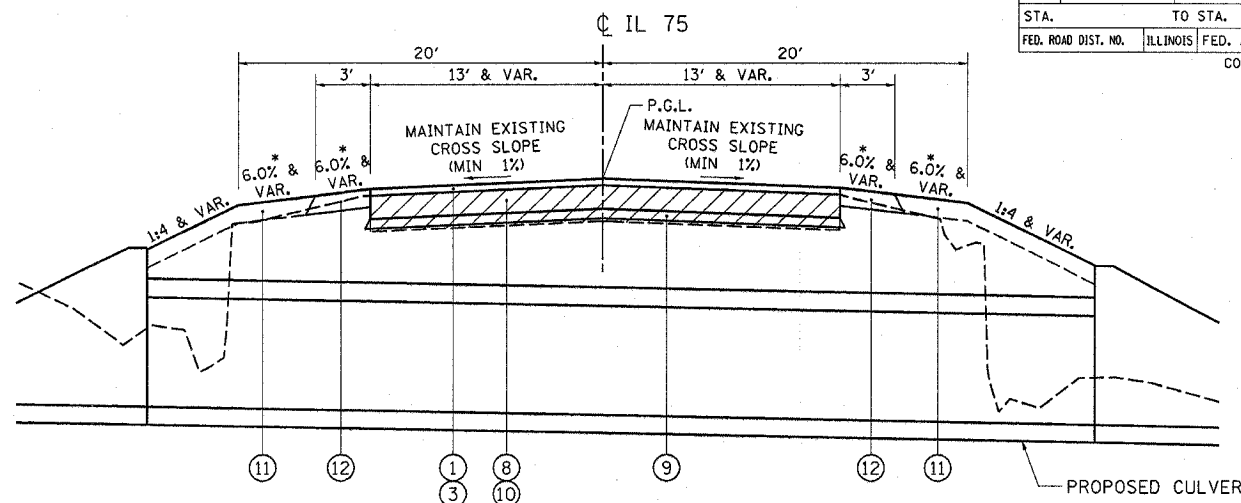

TYPICAL SECTION - RECONSTRUCTION AT ACROSS-ROAD CULVERTS

STA 10210+89 TO 10211+11 (*1)
STA 10248+41 TO 10248+97 (*4)
STA 10263+00 TO 10263+46 (*5)
STA 10306+43 TO 10307+05 (*6)
STA 10331+86 TO 10332+46 (*7)
STA 10356+81 TO 10357+43 (*8)
STA 10369+66 TO 10370+00 (*9)

* MAINTAIN PROPOSED 6" AGGREGATE SHOULDERS AT 6.0% AND PROPOSED 6" TOPSOIL AT 6.0% FOR FOLLOWING STATION RANGES:

STA 10209+00 TO 10213+00 (*1)
STA 10225+00 TO 10228+50 (*2/*3)
STA 10246+00 TO 10253+50 (*4)
STA 10260+00 TO 10265+50 (*5)
STA 10303+50 TO 10309+00 (*6)
STA 10328+50 TO 10337+00 (*7)
STA 10354+00 TO 10360+00 (*8)
STA 10367+00 TO 10372+00 (*9)

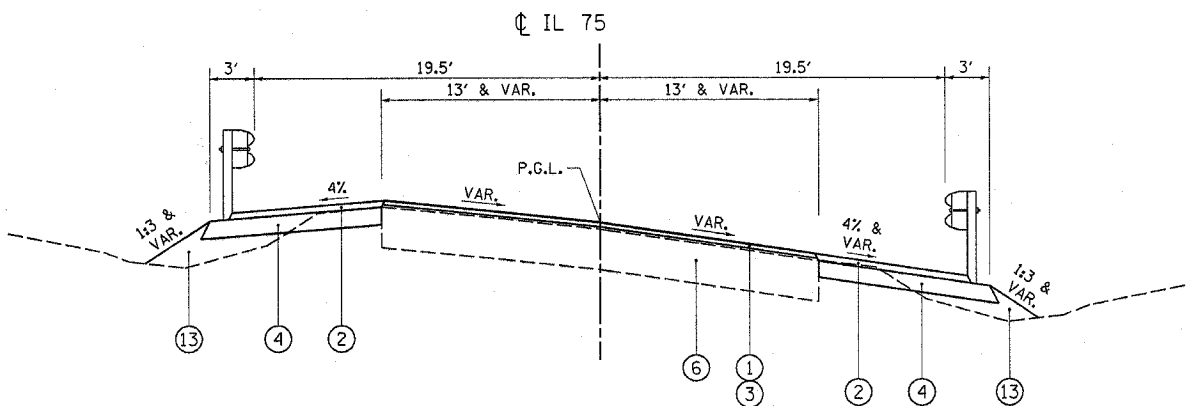

TYPICAL SECTION - RESURFACING SUPERELEVATED RIGHT, GUARDRAIL

STA 10515+50 TO 10520+00 (*13/*14)

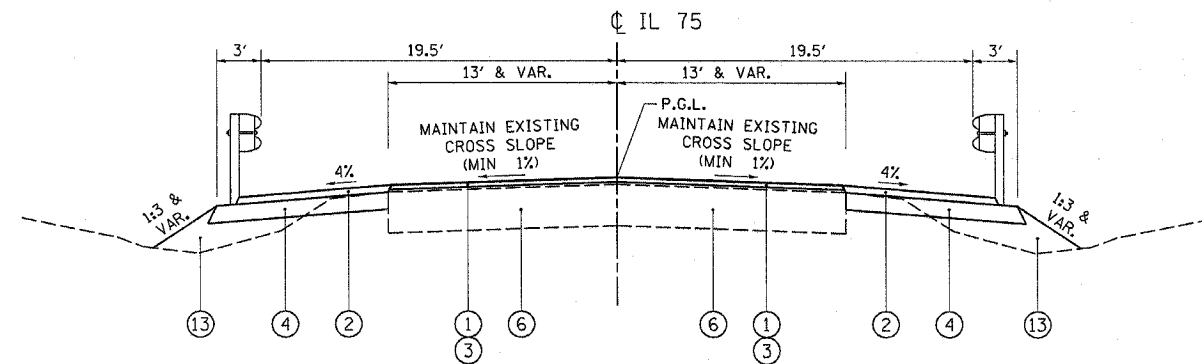

TYPICAL SECTION - RESURFACING, GUARDRAIL

STA 10171+23 TO 10175+74 (*1/*2) STA 10492+56 TO 10497+79 (*11/*12)
STA 10281+09 TO 10286+52 (*5/*6) STA 10582+29 TO 10586+29 (*15/*16)
STA 10395+26 TO 10398+26 (*7/*8) STA 10588+25 TO 10591+44 (*17/*18)

LEGEND

- ① 1 1/2", HOT-MIX ASPHALT SURFACE COURSE, MIX "D", N50
- ② 2", HOT-MIX ASPHALT SURFACE COURSE, MIX "C", N50
- ③ 3/4", LEVELING BINDER (MACHINE METHOD), N50
- ④ HOT-MIX ASPHALT SHOULDERS, 6"
- ⑤ AGGREGATE SHOULDERS, TYPE B
- ⑥ EXISTING +/-7" PCC PAVEMENT WITH +/-7" BITUMINOUS OVERLAY
- ⑦ TURF SHOULDER (SEE TURF SHOULDER SCHEDULE)
- ⑧ PAVEMENT REMOVAL, EXISTING +/-7" PCC PAVEMENT WITH +/-7" BITUMINOUS OVERLAY (REPLACE WITH ⑩)
- ⑨ SUB-BASE GRANULAR MATERIAL, TYPE A 4"
- ⑩ PORTLAND CEMENT CONCRETE BASE COURSE 9 3/4"
- ⑪ 6" TOPSOIL
- ⑫ 6", AGGREGATE SHOULDERS, TYPE B
- ⑬ SUITABLE EMBANKMENT

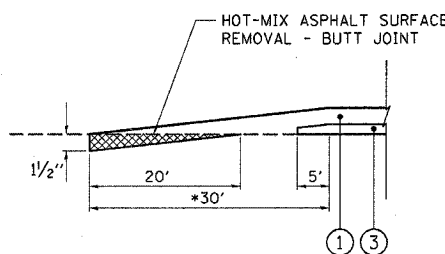

BUTT JOINT DETAILS (SIDEROAD)

* IF DISTANCE FROM BEGINNING OF BUTT JOINT TO THE MAINLINE EDGE OF PAVEMENT IS LESS THAN 30' TRANSITION THE SURFACE COURSE OVER THE SHORTER DISTANCE.

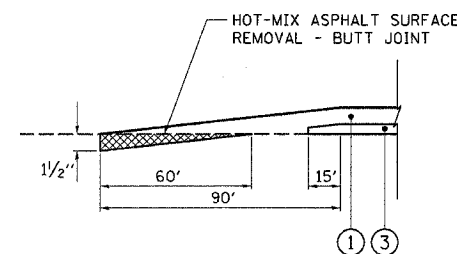

BUTT JOINT DETAILS (MAINLINE)

REVISIONS	
NAME	DATE

ILLINOIS DEPARTMENT OF TRANSPORTATION
F.A.P. ROUTE 505 (IL 75)

ILLINOIS ROUTE 75
TYPICAL SECTIONS

SCALE:
DATE: 12/15/06

DRAWN BY JMC
CHECKED BY DWB