

F.A.P. NO.	SECTION	COUNTY	TOTAL SHEETS	SHEET NO.
311	9 Y-N-2	COOK/DUPAGE	39	32
STA.		TO STA.		
FED. ROAD DIST. NO. 1		ILLINOIS FED. AID PROJECT		

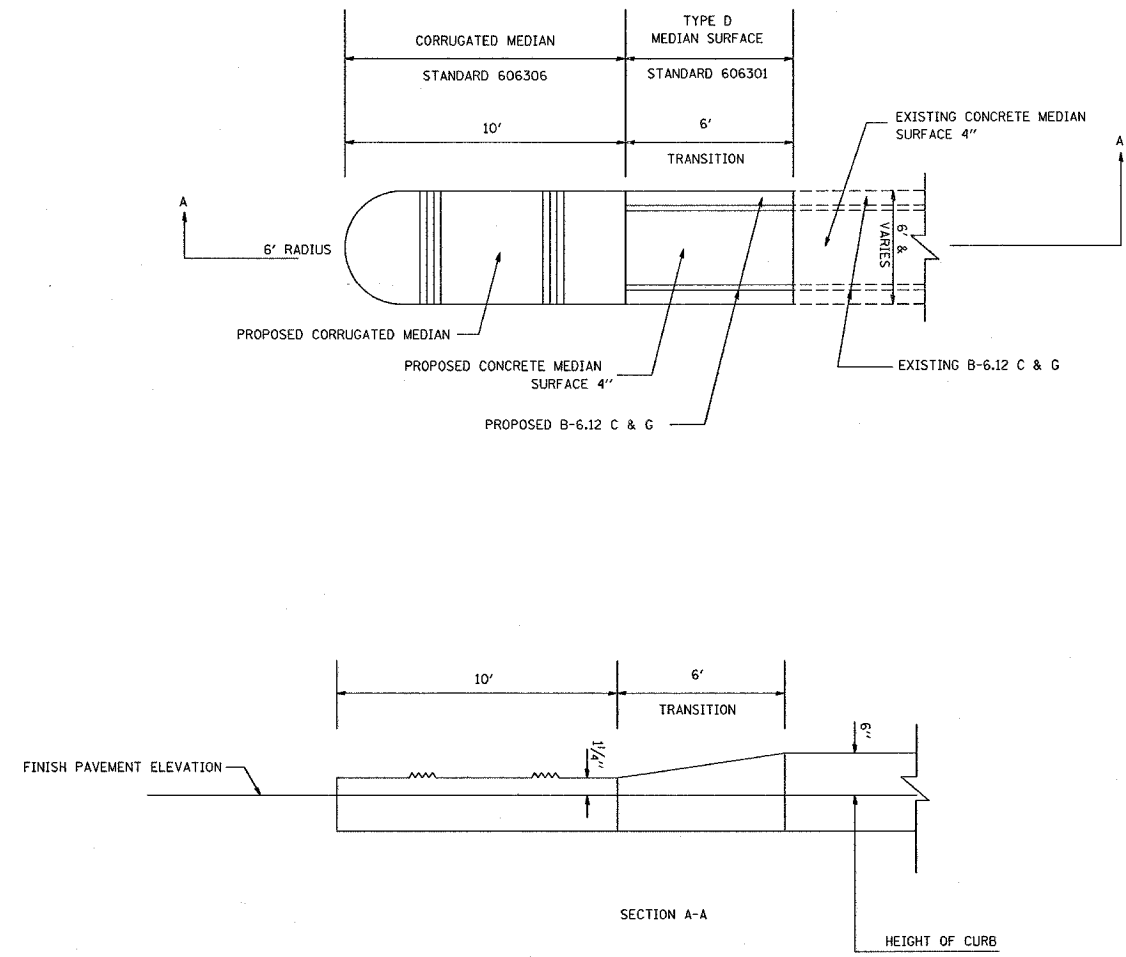

REVISIONS		ILLINOIS DEPARTMENT OF TRANSPORTATION
NAME	DATE	
		MEDIAN NOSE DETAIL
SCALE: VERT. DRAWN BY		CHECKED BY
DATE 12/11/2006		

12/11/2006
 c:\projects\p100903\design\design.dgn
 smf\thki