

GENERAL CONSTRUCTION ACTIVITY NOTES

1. THE AIRPORT MANAGER SHALL HAVE COMPLETE JURISDICTION OVER THE MAINTENANCE OF TRAFFIC AND CONSTRUCTION SEQUENCES AS OUTLINED IN THE CONTRACT SPECIAL PROVISIONS.
2. THE CONTRACTOR SHALL PROVIDE A MINIMUM OF SEVEN (7) DAYS NOTICE PRIOR TO INITIATING WORK IN ANY PHASE OF THE CONTRACT.
3. THE CONTRACTOR SHALL PROVIDE THE TEMPORARY SIGNS AND BARRICADES AS SHOWN ON THE PLANS AND AS DIRECTED BY THE ENGINEER. THIS WORK SHALL BE CONSIDERED PART OF THE TRAFFIC MAINTENANCE ITEM AND SHALL NOT BE MEASURED SEPARATELY FOR PAYMENT.
4. THE CONTRACTOR SHALL KEEP ALL ACTIVE ROADWAYS AND PAVEMENT AREAS CLEAR OF ALL MUD, DEBRIS OR ANY OTHER MATERIAL BY USE OF POWER BROOM, PUSH BROOM, OR BLOWER.
5. THE CONTRACTOR SHALL TAKE ANY STEPS NECESSARY TO ENSURE THE WORK AREAS ARE CLEAR OF ALL TRASH AND OTHER DEBRIS. THE CLEANLINESS OF THE JOB SITE WILL BE STRICTLY ENFORCED. IF THE ENGINEER OR AIRPORT DETERMINE THE JOBSITE TO BE UNSATISFACTORILY CLEANED, THE ENGINEER RESERVES THE RIGHT TO SUSPEND ALL ACTIVITY UNTIL THE CONDITIONS ARE RETURNED TO AN ACCEPTABLE STATE.
6. THE CONTRACTOR SHALL USE CARE WHEN WORKING IN THE VICINITY OF THE ACTIVE PARKING LOT. ANY DAMAGE DONE TO VEHICLES PARKED IN ACTIVE PARKING SPACES SHALL BE CONSIDERED THE FAULT OF THE CONTRACTOR AND THE CONTRACTOR SHALL BE LIABLE FOR ANY REPAIR CHARGES NECESSARY. THE CONTRACTOR SHALL MAKE ANY ADDITIONAL MEASURES, SUCH AS SIGNS, FENCES, ETC., THAT THEY FEEL IS NECESSARY TO PROTECT THE VEHICLES AND THE GENERAL PUBLIC. THESE MEASURES SHALL BE CONSIDERED INCIDENTAL TO THE CONTRACT.
7. THE CONTRACTOR SHALL ONLY STORE MATERIALS AND EQUIPMENT IN THE STAGING AREA SHOWN ON THE PLANS.
8. THE CONTRACTOR'S PERSONNEL MAY ONLY PARK IN THE DESIGNATED AREAS AS SHOWN. THE CONTRACTOR'S PERSONNEL WILL NOT BE ALLOWED TO PARK IN THE SPACES RESERVED FOR THE GENERAL PUBLIC.
9. THE CONTRACTOR SHALL NOT BE ALLOWED TO START EACH PHASE WITHOUT THE APPROVAL OF THE AIRPORT DIRECTOR IF HE IS BEHIND HIS ORIGINAL SCHEDULE.

UN052

REVISIONS		
NUMBER	BY	DATE

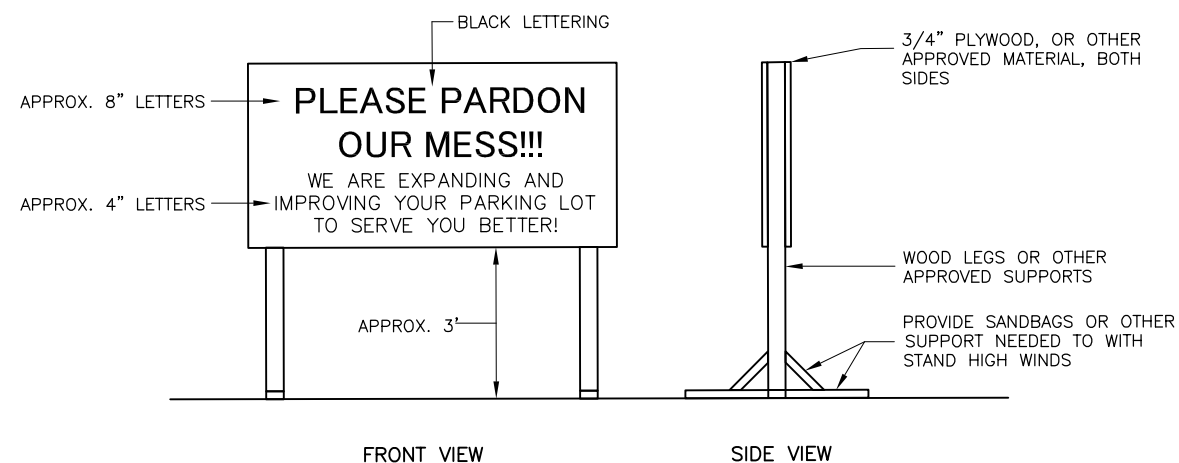
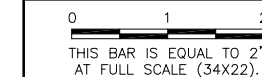

TEMPORARY SIGN NOTES

1. SIGN SHALL BE 4' X 8' X 3/4" PLYWOOD OR OTHER APPROVED MATERIAL.
2. CONTRACTOR SHALL PROVIDE 1 SINGLE SIDED SIGNS TO BE INSTALLED AT THE ENTRANCE OF THE PARKING LOT/CONSTRUCTION AREA.

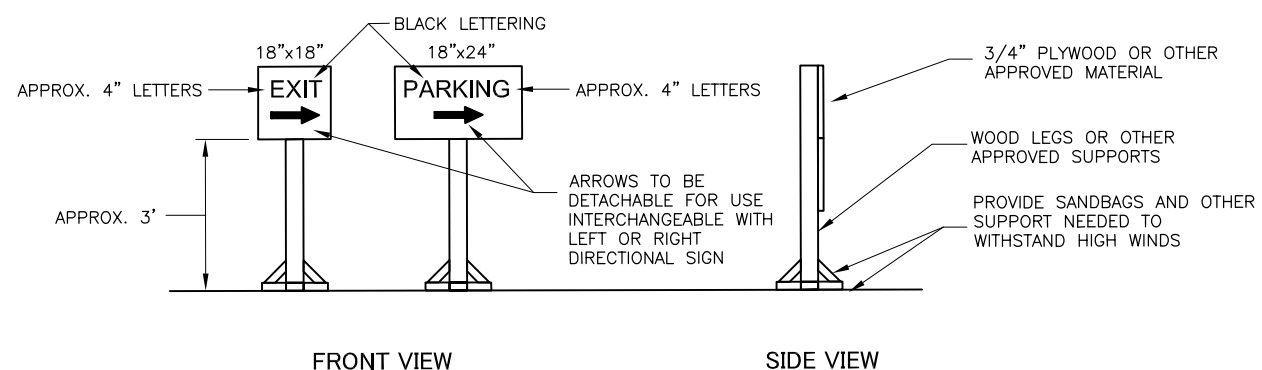

TEMPORARY SIGN NOTES

1. "EXIT" SIGNS SHALL BE 18" X 18" X 3/4" PLYWOOD OR OTHER APPROVED MATERIAL.
2. "PARKING" SIGNS SHALL BE 18" X 24" X 3/4" PLYWOOD OR OTHER APPROVED MATERIAL.
3. "EXIT" OR "PARKING" SIGNS SHALL BE PLACED AT LOCATIONS DESIGNATED BY THE RESIDENT ENGINEER FOR EACH PHASE.
4. THE CONTRACTOR SHALL PROVIDE 10 "EXIT" SIGNS AND 5 "PARKING" SIGNS.
5. SIGNS WILL EITHER HAVE A RIGHT, LEFT, OR UP ARROW. THE RESIDENT ENGINEER SHALL DETERMINE HOW MANY OF EACH DIRECTION ARE NEEDED PRIOR TO EACH PHASE. THE ARROWS ARE TO BE REMOVABLE SO EACH SIGN IS CAPABLE OF POINTING LEFT OR RIGHT AS NEEDED. SIGNS WILL ONLY BE PAID FOR ONCE. SWITCHING DIRECTIONS AND/OR MOVING SIGNS SHALL NOT BE CONSIDERED FOR PAYMENT.
6. SIGNS MAY BE MOUNTED ON BARRICADES PROVIDED THAT THEY ARE MOUNTED IN A MANNER TO PREVENT THEM FROM BLOWING OVER AND BECOMING DAMAGED OR UNUSABLE.

TEMPORARY SIGN DETAIL

N.T.S.

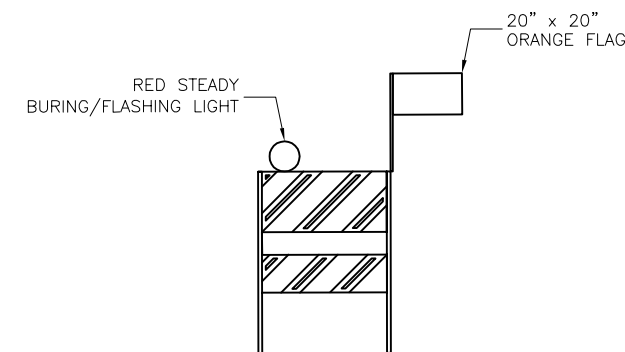

FLASHER BARRICADE DETAIL

N.T.S.

FLASHER BARRICADE NOTES

1. LIGHT TO BE BATTERY OPERATED. LENS TO BE RED, BI-DIRECTIONAL, AND BE ABLE TO ROTATE 90 DEGREES.
2. SANDBAGS TO BE PLACED ON EACH SUPPORT BRACE AS REQUIRED TO PREVENT DISPLACEMENT BY WIND, JET OR PROP BLAST.
3. NO SEPARATE PAYMENT WILL BE MADE FOR THIS ITEM. COSTS TO BE CONSIDERED INCIDENTAL TO THE PROJECT.
4. PLACE AT MAXIMUM 10' INTERVALS.

UNIVERSITY OF ILLINOIS
 WILLARD AIRPORT
 SAVOY, ILLINOIS

RELOCATE ENTRANCE ROADWAY &
 REHABILITATE OLD TERMINAL PARKING LOT
 CONSTRUCTION ACTIVITY PLAN
 DETAILS 2

© Copyright GMT, Inc.

GMT
 CRAWFORD, MURPHY & TILLY, INC.
 CONSULTING ENGINEERS
 License No. 184-000613



DESIGN BY:	CBG
DRAWN BY:	CMT
CHECKED BY:	KLB
APPROVED BY:	CET
DATE:	4/19/2013
JOB No:	11059-05-00

IL PROJ. NO. CMI-4269