

UN052

REVISIONS		
NUMBER	BY	DATE

0 1 2
 THIS BAR IS EQUAL TO 2"
 AT FULL SCALE (34X22).

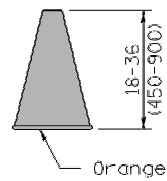

CONE

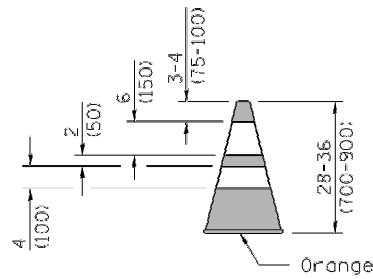

REFLECTORIZED CONE

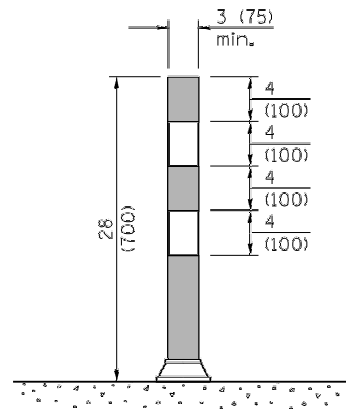

FLEXIBLE DELINEATOR

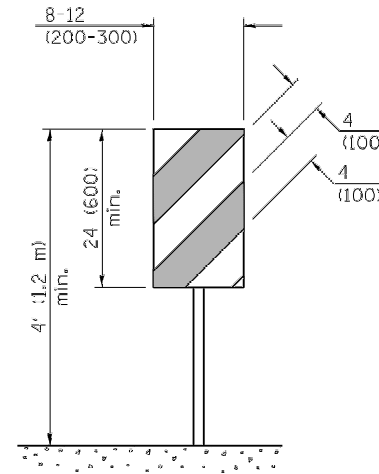

**VERTICAL PANEL
 POST MOUNTED**

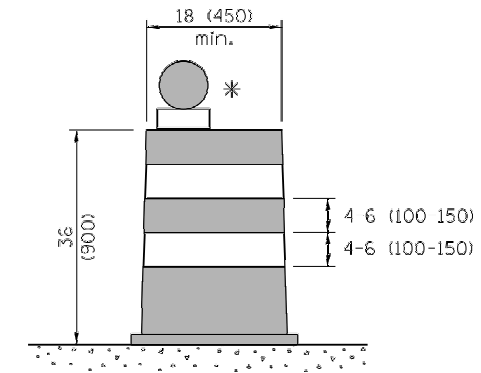

DRUM

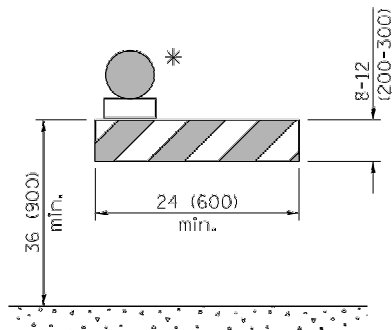

TYPE I BARRICADE

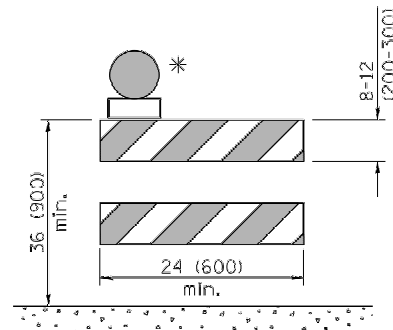

TYPE II BARRICADE

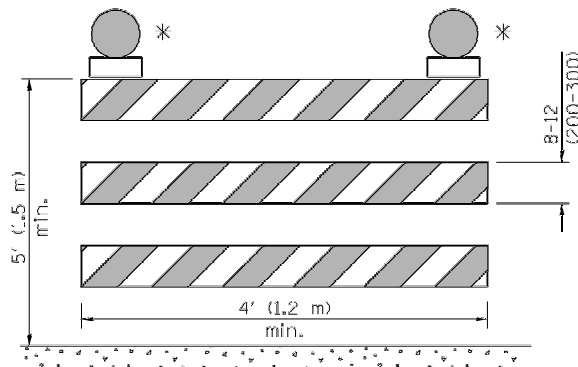

TYPE III BARRICADE

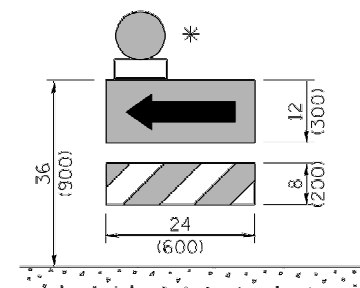

**DIRECTION INDICATOR
 BARRICADE**

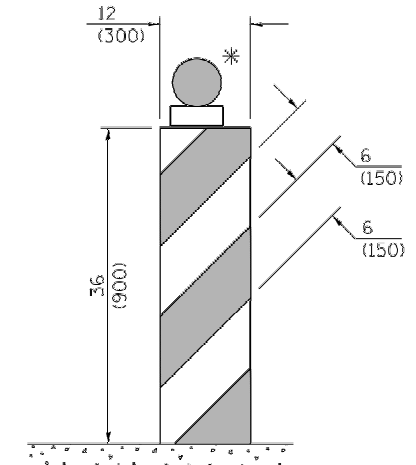

VERTICAL BARRICADE

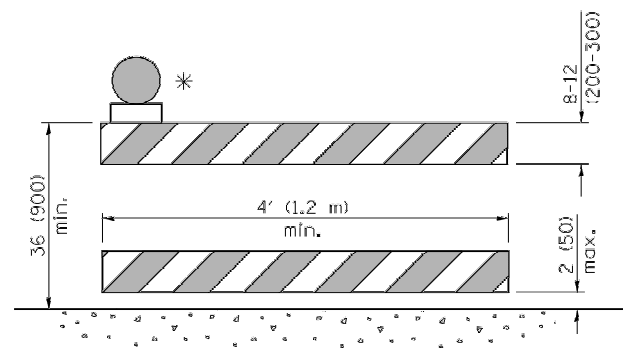

**DETECTABLE PEDESTRIAN
 CHANNELIZING BARRICADE**

* Warning lights (if required)

GENERAL NOTES

All heights shown shall be measured above the pavement surface.

All dimensions are in inches (millimeters) unless otherwise shown.

DATE	REVISIONS
1-1-12	Added DETECTABLE PEDESTRIAN CHANNELIZING BARRICADE.
1-1-09	Switched units to English (metric). Omitted light on vertical panel.

TRAFFIC CONTROL DEVICES

(Sheet 1 of 3)

STANDARD 701901-02

UNIVERSITY OF ILLINOIS
 WILLARD AIRPORT
 SAVOY, ILLINOIS

RELOCATE ENTRANCE ROADWAY &
 REHABILITATE OLD TERMINAL PARKING LOT
 CONSTRUCTION ACTIVITY PLAN
 DETAILS 1

© Copyright CMT, Inc.
CMT
 CRAWFORD, MURPHY & TILLY, INC.
 CONSULTING ENGINEERS
 License No. 184-000613



DESIGN BY:	CBG
DRAWN BY:	CMT
CHECKED BY:	KLB
APPROVED BY:	CET
DATE:	4/19/2013
JOB No:	11059-05-00
IL PROJ. NO.	CMI-4269
SHEET	10 OF 38 SHEETS

Illinois Department of Transportation

APPROVED January 1, 2012
 ENGINEER OF OPERATIONS
 APPROVED January 1, 2012
 ENGINEER OF DESIGN AND ENVIRONMENT

ISSUED 1-1-12