

SUMMARY OF QUANTITIES

0028 0004

PAY ITEM	DESCRIPTION	UNIT	SRTS	STU	TOTAL
20100110	TREE REMOVAL (6 TO 15 UNITS DIAMETER)	UNIT	0	18	18
20100210	TREE REMOVAL (OVER 15 UNITS DIAMETER)	UNIT	0	112	112
20200100	EARTH EXCAVATION	CU YD	432	2159	2591
20201200	REMOVAL AND DISPOSAL OF UNSUITABLE MATERIAL	CU YD	100	200	300
20800150	TRENCH BACKFILL	CU YD	5	341	346
25000115	SEEDING, CLASS 1B	ACRE	0.5	2.5	3
25000400	NITROGEN FERTILIZER NUTRIENT	POUND	50	250	300
25000500	PHOSPHORUS FERTILIZER NUTRIENT	POUND	50	250	300
25000600	POTASSIUM FERTILIZER NUTRIENT	POUND	50	250	300
25000700	AGRICULTURAL GROUND LIMESTONE	TON	1	5	6
25100115	MULCH, METHOD 2	ACRE	0.5	2.5	3
25100630	EROSION CONTROL BLANKET	SQ YD	500	300	800
28000200	EARTH EXCAVATION FOR EROSION CONTROL	CU YD	50	100	150
28000250	TEMPORARY EROSION CONTROL SEEDING	POUND	50	250	300
28000305	TEMPORARY DITCH CHECKS	FOOT	80	30	110
28000400	PERIMETER EROSION BARRIER	FOOT	300	400	700
28000500	INLET AND PIPE PROTECTION	EACH	2	2	4
28000510	INLET FILTERS	EACH	0	20	20
28100107	STONE RIPRAP, CLASS A4	SQ YD	0	110	110
28200200	FILTER FABRIC	SQ YD	0	110	110
30200650	PROCESSING MODIFIED SOIL 12"	SQ YD	0	6450	6450
30201500	LIME	TON	0	275	275
31101000	SUBBASE GRANULAR MATERIAL, TYPE B	TON	200	400	600
35101600	AGGREGATE BASE COURSE, TYPE B 4"	SQ YD	2660	80	2740
35102000	AGGREGATE BASE COURSE, TYPE B 8"	SQ YD	0	160	160
40201000	AGGREGATE FOR TEMPORARY ACCESS	TON	0	100	100
40600100	BITUMINOUS MATERIALS (PRIME COAT)	GALLON	665	55	720
40603080	HOT-MIX ASPHALT BINDER COURSE, IL-19.0, N50	TON	0	1675	1675
40603310	HOT-MIX ASPHALT SURFACE COURSE, MIX "C", N50	TON	315	650	965
40800050	INCIDENTAL HOT-MIX ASPHALT SURFACING	TON	0	50	50
42000200	PORTLAND CEMENT CONCRETE PAVEMENT 7"	SQ YD	0	80	80
42400100	PORTLAND CEMENT CONCRETE SIDEWALK 4 INCH	SQ FT	500	6200	6700
42400800	DETECTABLE WARNINGS	SQ FT	160	110	270
44000100	PAVEMENT REMOVAL	SQ YD	3	350	353
44000400	GUTTER REMOVAL	FOOT	0	200	200
48203100	HOT-MIX ASPHALT SHOULDERS	TON	0	30	30
50105220	PIPE CULVERT REMOVAL	FOOT	0	285	285
54213447	END SECTIONS 12"	EACH	3	0	3
54213456	END SECTIONS 21"	EACH	0	1	1
542D0217	PIPE CULVERTS, CLASS D, TYPE 1 12"	FOOT	37	0	37
550A0050	STORM SEWERS, CLASS A, TYPE 1 12"	FOOT	0	823	823
550A0070	STORM SEWERS, CLASS A, TYPE 1 15"	FOOT	0	217	217
60100925	PIPE DRAINS 8"	FOOT	0	12	12
60218500	MANHOLES, TYPE A, 4'-DIAMETER, TYPE 3 FRAME AND GRATE	EACH	0	9	9
60235700	INLETS, TYPE A, TYPE 3 FRAME AND GRATE	EACH	0	6	6
60236200	INLETS, TYPE A, TYPE 8 GRATE	EACH	1	0	1
60240215	INLETS, TYPE B, TYPE 1 FRAME, CLOSED LID	EACH	0	1	1
60240220	INLETS, TYPE B, TYPE 3 FRAME AND GRATE	EACH	0	1	1
60404210	FRAMES AND GRATES, TYPE 2	EACH	0	2	2
60600095	CLASS SI CONCRETE (OUTLET)	CU YD	0	5	5
60603800	COMBINATION CONCRETE CURB AND GUTTER, TYPE B-6.12	FOOT	0	200	200
60605000	COMBINATION CONCRETE CURB AND GUTTER, TYPE B-6.24	FOOT	0	3650	3650
67000500	ENGINEER'S FIELD OFFICE, TYPE B	CAL MO	2	2	4
67100100	MOBILIZATION	LSUM	0.25	0.75	1
72000100	SIGN PANEL - TYPE 1	SQ FT	71	24	95
72900200	METAL POST - TYPE B	FOOT	215	60	275
* 78000200	THERMOPLASTIC PAVEMENT MARKING - LINE 4"	FOOT	600	3800	4400
* 78000400	THERMOPLASTIC PAVEMENT MARKING - LINE 6"	FOOT	180	130	310
* 78000600	THERMOPLASTIC PAVEMENT MARKING - LINE 12"	FOOT	60	90	150
* 78006130	PREFORMED THERMOPLASTIC PAVEMENT MARKING - LINE 6"	FOOT	0	100	100
X0326657	RELOCATE SIGN, SPECIAL	EACH	0	10	10
X0327235	LOCATING UNDERGROUND UTILITIES	FOOT	100	200	300
X6024240	INLETS, SPECIAL	EACH	0	2	2
X6061700	COMBINATION CONCRETE CURB AND GUTTER, TYPE B (SPECIAL)	FOOT	0	80	80
X7010216	TRAFFIC CONTROL AND PROTECTION, (SPECIAL)	LSUM	0.25	0.75	1
Z0056608	STORM SEWER (WATER MAIN REQUIREMENTS) 12 INCH	FOOT	0	49	49
Z0056610	STORM SEWER (WATER MAIN REQUIREMENTS) 15 INCH	FOOT	0	103	103
Z0056612	STORM SEWER (WATER MAIN REQUIREMENTS) 18 INCH	FOOT	0	277	277
Z0056614	STORM SEWER (WATER MAIN REQUIREMENTS) 21 INCH	FOOT	0	364	364

* - SPECIALTY ITEM

GENERAL NOTES

1. THIS IMPROVEMENT SHALL BE CONSTRUCTED ACCORDING TO WITH THE I.D.O.T. "STANDARD SPECIFICATIONS FOR ROAD AND BRIDGE CONSTRUCTION" ADOPTED JANUARY 1, 2012 AND THE SPECIAL PROVISIONS FOR THIS PROJECT.
2. INFORMATION ON THE PLANS REGARDING UTILITIES IS TAKEN FROM THE BEST AVAILABLE RECORDS, BUT IS NOT REPRESENTED AS BEING CORRECT OR COMPLETE. THE CONTRACTOR SHALL NOTIFY J.U.L.I.E. IN ADVANCE OF CROSSING OVER OR UNDER UTILITIES.
3. THE CONTRACTOR SHALL USE ALL DUE PRECAUTION NOT TO DAMAGE OR DISTURB UTILITIES. THE ENTIRE COST OF MAKING REPAIRS TO, OR REPLACEMENT OF, ANY DAMAGED LINE WILL BE THE FULL RESPONSIBILITY OF THE CONTRACTOR.
4. ALL ELEVATIONS REFER TO U.S.G.S. MEAN SEA LEVEL.
5. THE CONTRACTOR SHALL VERIFY ALL ELEVATIONS SHOWN ON THE PLANS PRIOR TO FABRICATION OF DRAINAGE STRUCTURES.
6. THE CONTRACTOR SHALL CONSTRUCT TEMPORARY EROSION CONTROL SYSTEMS AS DIRECTED BY THE ENGINEER TO CONTROL EROSION AND SEDIMENT DAMAGE TO ADJACENT PROPERTIES AND WATER RESOURCES. THIS WORK SHALL BE PERFORMED ACCORDING TO SECTION 280 OF THE STANDARD SPECIFICATIONS, HIGHWAY STANDARD 280001, THE EROSION CONTROL PLAN AND THE STORM WATER POLLUTION PREVENTION PLAN.
7. ALL EXCAVATIONS SHALL BE PROTECTED, IF NOT BACKFILLED THE SAME DAY, BY BARRICADES & APPROPRIATE LIGHTS. COSTS FOR PROVIDING ABOVE SHALL BE CONSIDERED INCLUDED IN THE COST FOR TRAFFIC CONTROL AND PROTECTION.
8. IF ASH TREES ARE REMOVED ON THE PROJECT, THE CONTRACTOR SHALL BECOME FAMILIAR WITH AND COMPLY WITH MEASURES SPECIFIED BY THE ILLINOIS DEPARTMENT OF AGRICULTURE (IDOA) TO PREVENT THE SPREAD OF THE EMERALD ASH BORER. THE IDOA INFORMATION FOR ASH TREE REMOVAL CAN BE FOUND ON THE IDOA WEBSITE AT WWW.AGR.STATE.IL.US/EAB.

LEGEND

- EXISTING UTILITY POLE - ○
- EXISTING LIGHT POLE - X
- EXISTING GUY WIRE - ←
- EXISTING ELECTRIC SPICE BOX - □^E
- EXISTING TELEPHONE SPICE BOX - □^Δ
- EXISTING CABLE SPICE BOX - □^{TV}
- EXISTING GAS METER - ⊗
- EXISTING WATER METER - ⊗
- EXISTING WATER VALVE - ⊕
- EXISTING GAS VALVE - ⊗
- EXISTING FIRE HYDRANT - ⊕^{PH}
- EXISTING SANITARY MANHOLE TOP - ⊗
- EXISTING STORM MANHOLE TOP - ⊗
- BENCHMARK - BM
- RIGHT-OF-WAY MARKER - S^{MON}
- AXLE FOUND - ○^{AX}
- BOLT FOUND - ○^B
- CHISELED "X" FOUND - X
- PIN FOUND - ○^{IP}
- PINCH PIPE FOUND - ○^{IP}
- PK NAIL FOUND - ○^{PK}
- RAILROAD SPIKE FOUND - ○^{RR}
- STONE FOUND - □^{STONE}
- BRASS MONUMENT FOUND - ○^{MON}
- IRON PIPE FOUND - ○^{IP}
- MONUMENT FOUND - □^{MON}
- REBAR FOUND - ○^{RBR}
- EXISTING MAILBOX - P
- EXISTING FENCE POST - ⊕
- EXISTING GATE POST - ⊕
- EXISTING FLAG POLE - ⊕
- EXISTING GUARD POST - ○^{GP}
- EXISTING ADVERTISING SIGN - T
- EXISTING TRAFFIC SIGN - T
- EXISTING TRAFFIC SIGNAL - ○
- EXISTING TRAFFIC SIGNAL CONTROLLER - ⊞
- EXISTING HANDHOLE - □
- EXISTING DOUBLE HANDHOLE - □
- EXISTING MAST ARM BASE - ○
- EXISTING DECIDUOUS TREE / SIZE - ○^{XX}
- EXISTING EVERGREEN TREE / SIZE - ●^{XX}
- EXISTING STUMP / SIZE - P^{XX}
- EXISTING BUSH - ⊕
- EXISTING SHRUB - ⊕
- EXISTING TREE TO BE REMOVED - X^{XX}
- PROPOSED TRAFFIC SIGN - T
- PROPOSED DECIDUOUS TREE / SIZE - ○^{XX}
- PROPOSED EVERGREEN TREE / SIZE - ●^{XX}
- PROPOSED BUSH - ⊕
- PROPOSED PLANT - *

EXISTING CONSTRUCTION

- EXISTING BRUSH / HEDGE / TREE LINE
- EXISTING MAJOR CONTOUR
- EXISTING MINOR CONTOUR
- EXISTING CULVERT
- EXISTING DITCH
- EXISTING OVERHEAD ELECTRIC
- EXISTING UNDERGROUND ELECTRIC
- EXISTING EASEMENT
- EXISTING FENCE
- EXISTING FORCEMAIN
- EXISTING GAS
- EXISTING GUARDRAIL
- EXISTING RIGHT-OF-WAY
- EXISTING SANITARY SEWER
- EXISTING SECTION LINE
- EXISTING STORM SEWER
- EXISTING UNDERGROUND TELEPHONE
- EXISTING WATER

PROPOSED CONSTRUCTION

- PROPOSED CENTERLINE
- PROPOSED CONSTRUCTION LIMITS
- PROPOSED MAJOR CONTOUR
- PROPOSED MINOR CONTOUR
- PROPOSED CULVERT
- PROPOSED DITCH
- PROPOSED PERIMETER EROSION BARRIER
- PROPOSED EASEMENT
- PROPOSED RIGHT-OF-WAY
- PROPOSED STORM SEWER

REVISIONS	

Sheppard, Morgan & Schwaab, Inc.
 CONSULTING ENGINEERS AND LAND SURVEYORS
 215 Market Street, P.O. Box E, Alton, IL 62002 618-242-3955 Email: ra@smse.com
 10 Central Industrial Drive, Suite 3, Granite City, IL 62040 618-277-5410 Email: ra@smse.com
 DESIGN FIRM # 184-000992

STAMPER LANE - GODFREY, ILLINOIS
 FAU ROUTE 8950
 10-00022-01-PV
 10-00024-00-SW

SUMMARY OF QUANTITIES, GENERAL NOTES AND SMS LEGEND

DWG. NO.
 CHECKED BY: []
 DESIGNED BY: []
 DRAWN BY: []
 DATE: MARCH, 2013

SCALE: NOT TO SCALE
 SHEET 2 OF 50

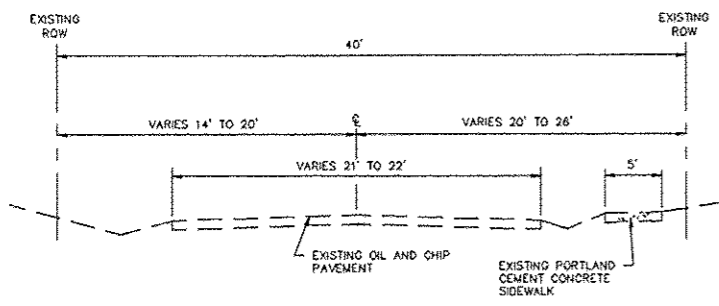

EXISTING TYPICAL SECTION
STA. 16+91.62 TO STA. 27+43
NOT TO SCALE

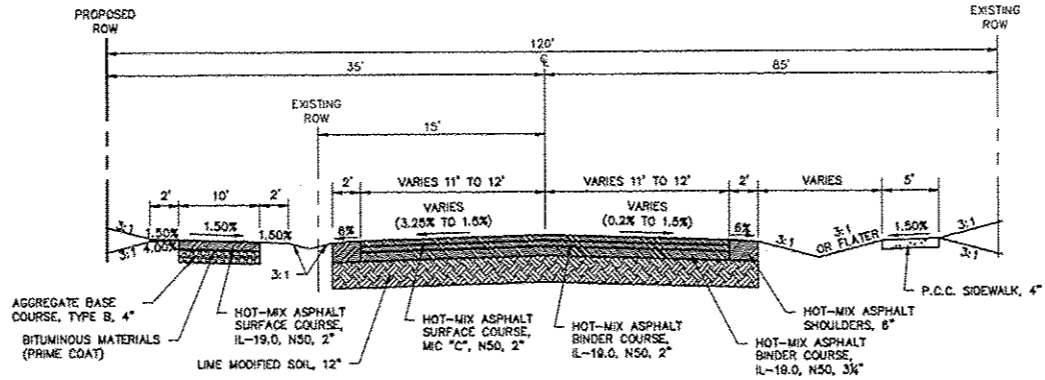

PROPOSED TYPICAL SECTION
STA. 28+13.53 TO STA. 29+00
NOT TO SCALE

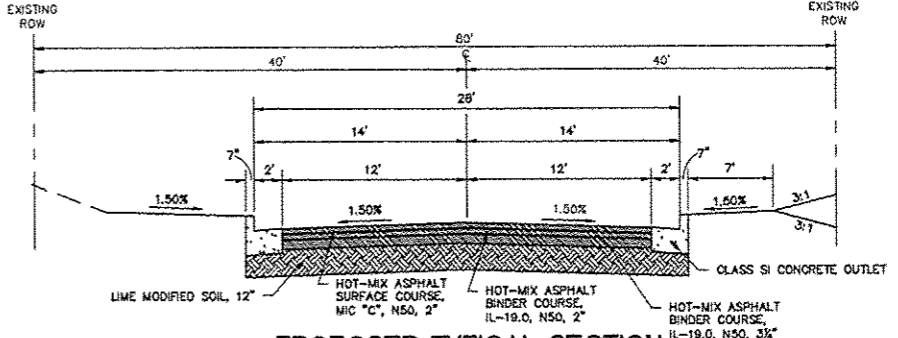

PROPOSED TYPICAL SECTION
STA. 47+24.63 TO STA. 47+37
NOT TO SCALE

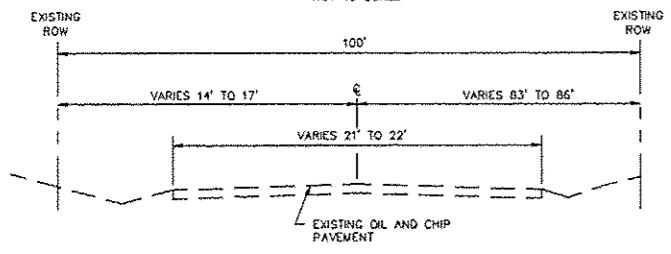

EXISTING TYPICAL SECTION
STA. 27+43 TO STA. 40+87
NOT TO SCALE

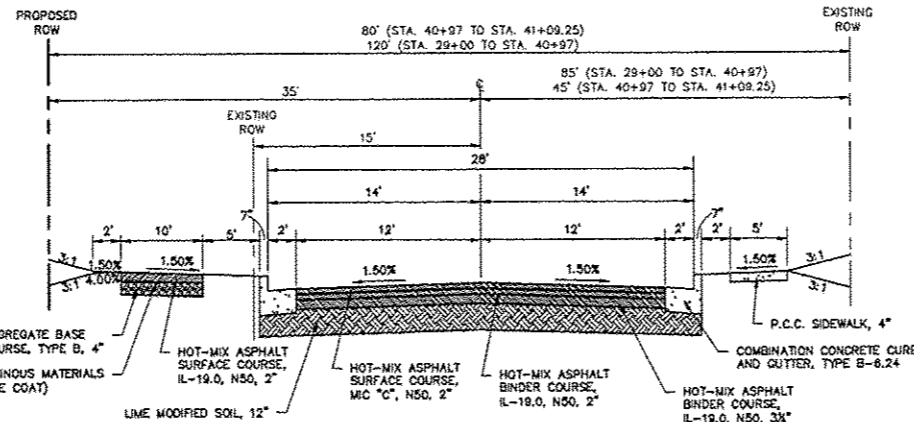

PROPOSED TYPICAL SECTION
STA. 29+00 TO STA. 41+09.25
NOT TO SCALE

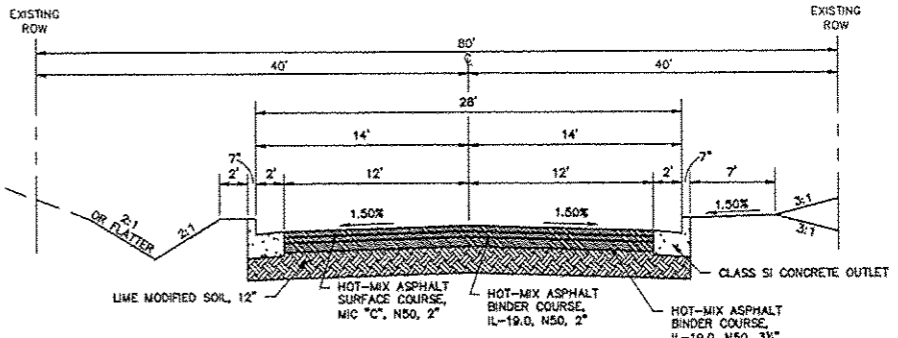

PROPOSED TYPICAL SECTION
STA. 47+37 TO STA. 47+50
NOT TO SCALE

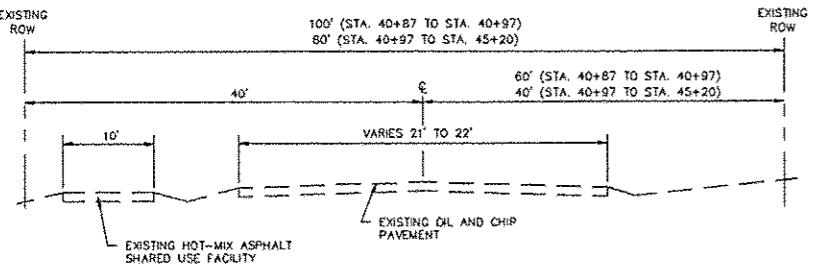

EXISTING TYPICAL SECTION
STA. 40+87 TO STA. 45+20
NOT TO SCALE

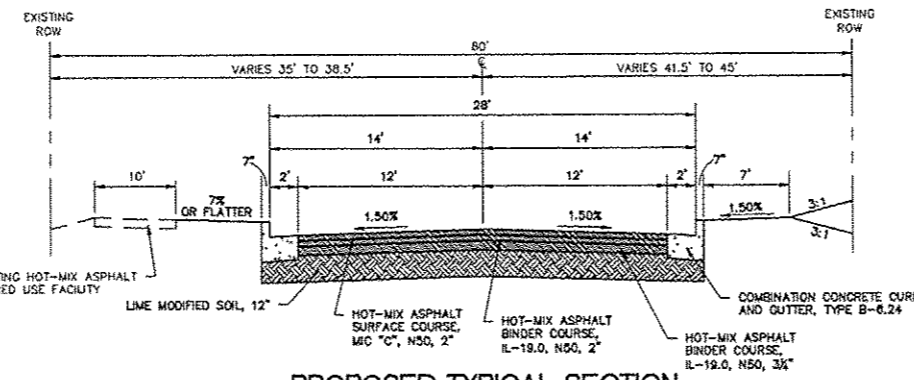

PROPOSED TYPICAL SECTION
STA. 41+09.25 TO STA. 45+20
NOT TO SCALE

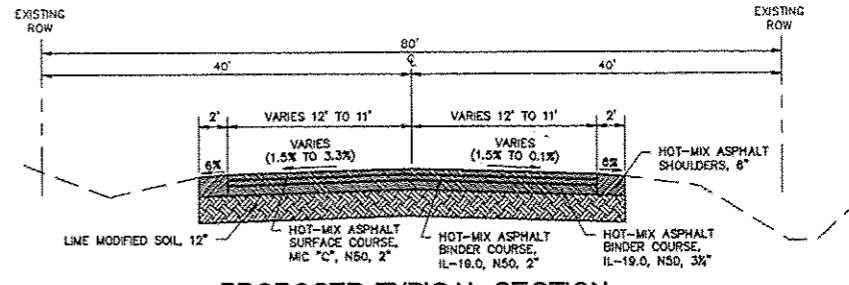

PROPOSED TYPICAL SECTION
STA. 47+50 TO STA. 48+08.59
NOT TO SCALE

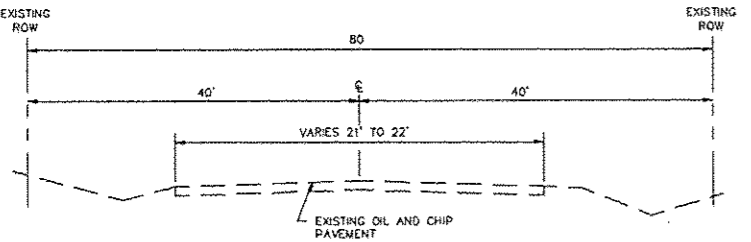

EXISTING TYPICAL SECTION
STA. 45+20 TO STA. 48+08.59
NOT TO SCALE

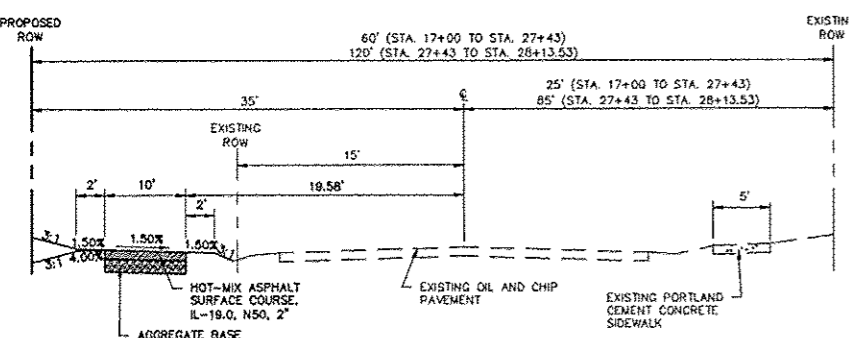

PROPOSED TYPICAL SECTION
STA. 16+91.62 TO STA. 28+13.53
NOT TO SCALE

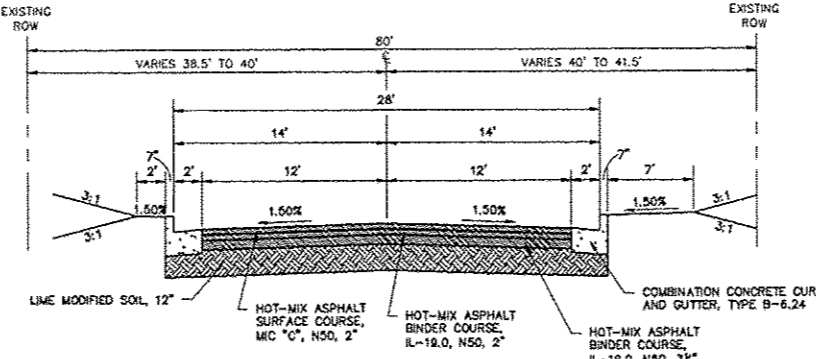

PROPOSED TYPICAL SECTION
STA. 45+20 TO STA. 47+24.63
NOT TO SCALE

PAVEMENT DESIGN DATA

DESIGN SPEED = 30 M.P.H.
CLASS II STREET
2013 AVERAGE DAILY TRAFFIC (A.D.T.) = 4,075
2033 AVERAGE DAILY TRAFFIC (A.D.T.) = 4,500
2023 STRUCTURAL DESIGN TRAFFIC (S.D.T.) = 4,290
PASSENGER VEHICLES (P.V.) = 4,078 (95%)
SINGLE UNITS (S.U.) = 172 (4%)
MULTIPLE UNITS (M.U.) = 42 (1%)

HMA PAVEMENT DESIGN

SSR: POOR
FLEXIBLE TRAFFIC FACTOR: 0.36
SELECTED DESIGN PG BINDER: PG 70-22
DESIGN PAVEMENT HMA TEMP: 82F
DESIGN HMA MODULUS (E_{AC}): 500 ksi
DESIGN HMA MICROSTRAIN: 190
PAVEMENT THICKNESS: 7 1/2"
SUBGRADE: LIME MODIFIED

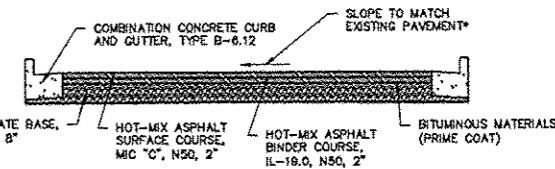

PROPOSED TYPICAL SECTION
SIDE STREETS
NOT TO SCALE

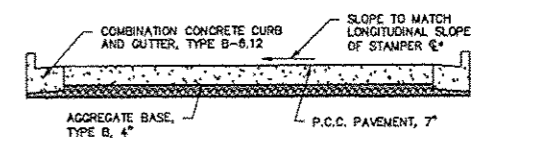

PROPOSED TYPICAL SECTION
SIDE STREETS
NOT TO SCALE

REVISIONS

SMS ENGINEERS
Sheppard, Morgan & Schwaab, Inc.
CONSULTING ENGINEERS AND LAND SURVEYORS
215 Market Street, P.O. Box 21, Alton, IL 62002 618-462-9755 E-mail: ms@smsengineers.com
10 Central Industrial Drive, Suite 3, Granite City, IL 62040 618-271-9700 E-mail: ms@smsengineers.com
DESIGN FIRM # 184-000892

STAMPER LANE - GODFREY, ILLINOIS
FAU ROUTE 8950
10-00022-01-PV
10-00024-00-SW
EXISTING AND PROPOSED TYPICAL SECTIONS

DWG. NO.	10-00022-01-PV
DATE	MARCH 2013
SCALE	NOT TO SCALE
SHEET	3 OF 50

*SEE SHEETS 16 FOR DETAILS

STORM SEWER STRUCTURE SCHEDULE

Node	Pay Item	Rim Elevation (ft)	Quantities
26+00S	INLETS, TYPE A, TYPE 8 GRATE	606.85	1
31+87	INLETS, TYPE B, TYPE 1 FRAME, CLOSED LID	607.15	1
31+88S	INLETS, TYPE A, TYPE 3 FRAME AND GRATE	605.31	6
31+88N	MANHOLES, TYPE A, 4'-DIAMETER, TYPE 3 FRAME AND GRATE	605.31	9
34+38N	MANHOLES, TYPE A, 4'-DIAMETER, TYPE 3 FRAME AND GRATE	600.87	
34+38S	INLETS, TYPE A, TYPE 3 FRAME AND GRATE	600.87	
36+88N	MANHOLES, TYPE A, 4'-DIAMETER, TYPE 3 FRAME AND GRATE	596.24	
36+88S	INLETS, TYPE A, TYPE 3 FRAME AND GRATE	596.24	
38+00N	INLETS, TYPE B, TYPE 3 FRAME AND GRATE	591.91	1
39+38N	MANHOLES, TYPE A, 4'-DIAMETER, TYPE 3 FRAME AND GRATE	589.46	
39+38S	INLETS, TYPE A, TYPE 3 FRAME AND GRATE	589.46	
40+17N	MANHOLES, TYPE A, 4'-DIAMETER, TYPE 3 FRAME AND GRATE	588.51	
40+17a	INLETS, SPECIAL	590.63	2
40+83N	INLETS, SPECIAL	589.69	
41+20N	MANHOLES, TYPE A, 4'-DIAMETER, TYPE 3 FRAME AND GRATE	587.75	
41+20S	MANHOLES, TYPE A, 4'-DIAMETER, TYPE 3 FRAME AND GRATE	587.75	
43+70S	MANHOLES, TYPE A, 4'-DIAMETER, TYPE 3 FRAME AND GRATE	584.65	
43+70N	INLETS, TYPE A, TYPE 3 FRAME AND GRATE	584.65	
46+20N	INLETS, TYPE A, TYPE 3 FRAME AND GRATE	582.77	
46+20S	MANHOLES, TYPE A, 4'-DIAMETER, TYPE 3 FRAME AND GRATE	582.77	
Outlet	END SECTIONS 21"		1
ES 1	END SECTIONS 12"		3
ES 2	END SECTIONS 12"		
ES 3	END SECTIONS 12"		

EARTHWORK SCHEDULE

Location	Cut	Shrinkage (20%)	Available	Fill	Balance (+/-)
16+90 to 28+13	180	36	144	23	121
21+50 to 23+75	1	0	1	48	-47
24+75 to 30+00	251	50	201	76	125
30+00 to 35+75	432	86	346	499	-154
35+75 to 41+20	776	155	621	604	17
41+20 to 46+84.64	827	165	662	247	415
46+84.64 to 48+08.59	124	25	99	53	46
Total	2591	518	2073	1550	523

REVISIONS

SMS ENGINEERS
 Sheppard, Morgan & Schwaab, Inc.
 CONSULTING ENGINEERS AND LAND SURVEYORS
 245 Market Street, P.O. Box E, Alton, IL 62628-9155, E-mail: sm&sc@sms-engineers.com
 10 Central Industrial Drive, Suite 3, Granite City, IL 62040, 618.377.9200, E-mail: ms@sms-engineers.com
 DESIGN FIRM # 184-000992

STORM SEWER PIPE SCHEDULE

Pipe	Upstream Node	Downstream Node	Length (ft)	Section Size	Material	Upstream Invert Elevation (ft)	Downstream Invert Elevation (ft)	Constructed Slope (ft/ft)	Trench Backfill (cy)
P-1	31+88S	31+88N	28	12 inch	RCCP	601.81	601.66	0.0054	4
P-2	31+87	31+88N	13	12 inch	RCCP	602.65	601.66	0.0765	2
P-3	31+88N	34+38N	250	12 inch	RCCP	601.56	597.22	0.0174	38
P-4	34+38S	34+38N	28	12 inch	RCCP	597.37	597.22	0.0054	4
P-5	34+38N	36+88N	250	12 inch	RCCP	597.12	592.59	0.0181	38
P-6	36+88S	36+88N	28	12 inch	RCCP	592.74	592.59	0.0054	4
P-7	36+88N	38+00N	112	12 inch	RCCP	592.49	588.41	0.0364	16
P-7A	38+00N	39+38N	138	15 inch	RCCP	588.16	585.56	0.0189	22
P-8	39+38S	39+38N	28	12 inch	RCCP	585.96	585.81	0.0054	4
P-9	39+38N	40+17N	79	15 inch	RCCP	585.51	584.76	0.0095	14
P-10	40+17a	40+17N	30	12 inch	RCCP	587.13	584.96	0.0723	2
P-11	40+17N	41+20N	103	15 inch	PVC	584.66	583.62	0.0101	19
P-12	40+83N	41+20N	49	12 inch	PVC	586.19	583.95	0.0457	3
P-13	41+20N	41+20S	27	18 inch	PVC	583.52	583.19	0.0122	6
P-14	41+20S	43+70S	250	18 inch	PVC	583.09	579.90	0.0128	64
P-15	43+70N	43+70S	28	12 inch	RCCP	581.15	581.00	0.0054	4
P-16	43+70S	46+20S	250	21 inch	PVC	579.65	578.15	0.0060	66
P-17	46+20N	46+20S	28	12 inch	RCCP	579.27	579.12	0.0054	4
P-18	46+20S	Outlet	114	21 inch	PVC	578.05	577.31	0.0065	27
P-19	26+00S	ES 1	17	12 inch	CMP	605.64	605.55	0.0050	3
P-20	ES 2	ES 3	20	12 inch	CMP	607.62	607.32	0.0140	2

RCCP - Reinforced Concrete Culvert, Storm Drain, and Sewer Pipe
 PVC - Polyvinyl Chloride Pipe
 CMP - Corrugated Metal Pipe

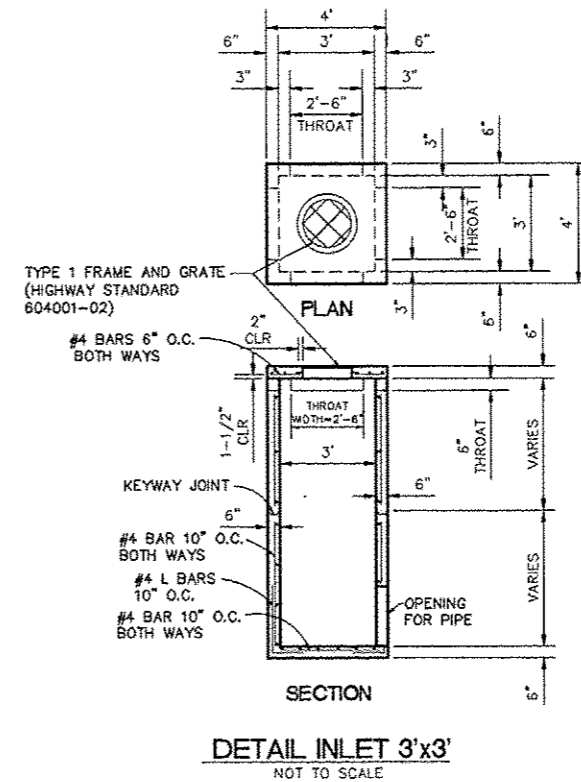

STAMPER LANE - GODFREY, ILLINOIS
 FAU ROUTE 8950
 10-00022-01-PV
 10-00024-00-SW
 SCHEDULE OF QUANTITIES AND INLET DETAIL

DWG. NO.	
REV. NO.	
REF. BK.	PG.
JOB NO.	438439
DSN. BY:	SJW
DWN. BY:	BCS
CHK. BY:	SJW
DATE:	MARCH, 2013
SCALE:	NOT TO SCALE
SHEET	4 OF 50

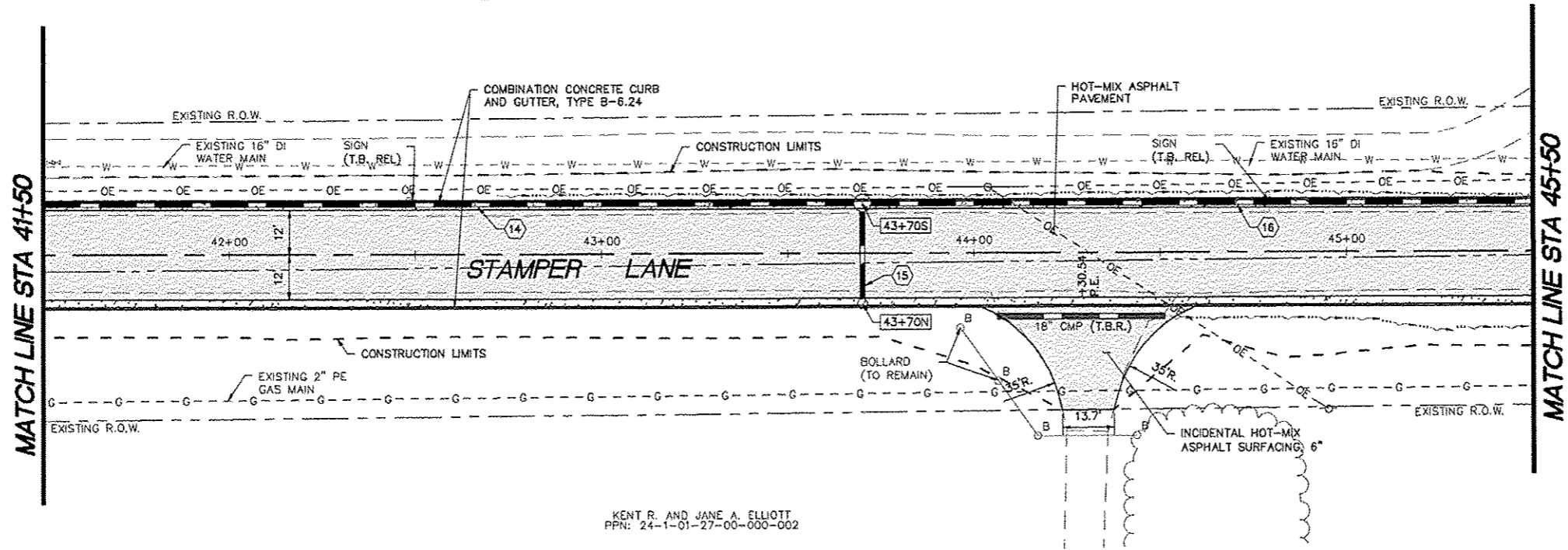

KENT R. AND JANE A. ELLIOTT
PPN: 24-1-01-27-00-000-002



REVISIONS

Sheppard, Morgan & Schwaab, Inc.
CONSULTING ENGINEERS AND LAND SURVEYORS
2715 North State, P.O. Box E, Alton, IL 62002 618-462-3755, E-mail: ms@smsengineers.com
10 Central Expressway, Suite 3, Oak Brook, IL 60151 630-577-0700, E-mail: ms@smsengineers.com
DESIGN FIRM # 184-000982

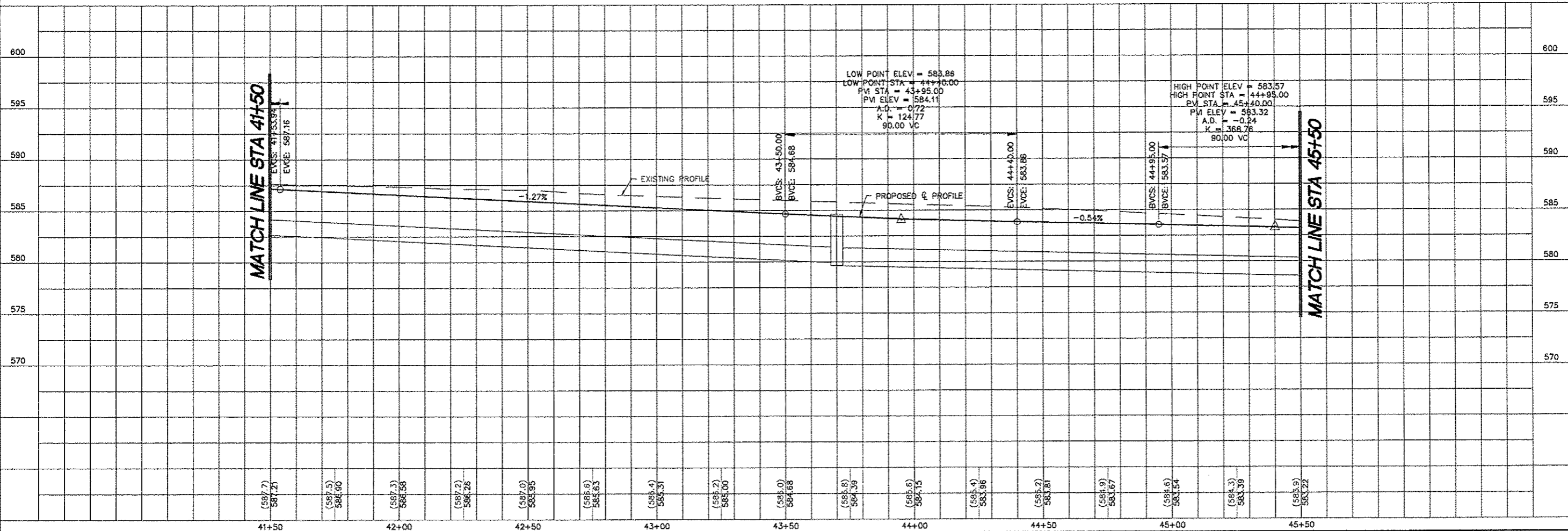

STAMPER LANE - GODFREY, ILLINOIS
FAU ROUTE 8950
10-00022-01-PV
10-00024-00-SW
PLAN AND PROFILE

DWG. NO.	
REF. BK.	PG.
JOB NO.	438439
DSN. BY:	SW
OWN. BY:	BCS
CHK. BY:	SW
DATE:	MARCH, 2013
HORIZ. SCALE:	1"=20'
VERT. SCALE:	1"=5'
SHEET	10 OF 50



CONTRACT 97528

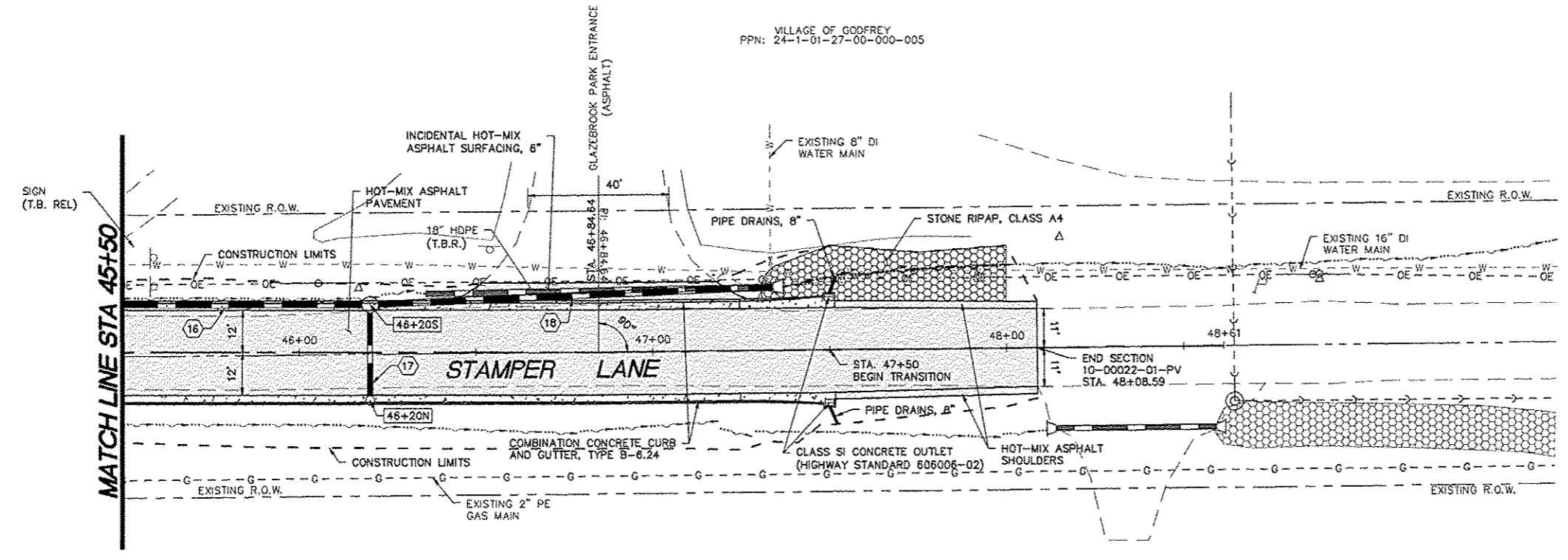

VILLAGE OF GODFREY
PPN: 24-1-01-27-00-000-005

KENT R. AND JANE A. ELLIOTT
PPN: 24-1-01-27-00-000-002

REVISIONS

Sheppard, Morgan & Schwaab, Inc.
CONSULTING ENGINEERS AND LAND SURVEYORS
215 Marco Street, P.O. Box E, Alton, IL 62002 6184231755 E-mail: ms@smgsurveyors.com
10 Central Industrial Drive, Suite 3, Granite City, IL 62041 6183773167 E-mail: ms@smgsurveyors.com
DESIGN FIRM # 184-000892

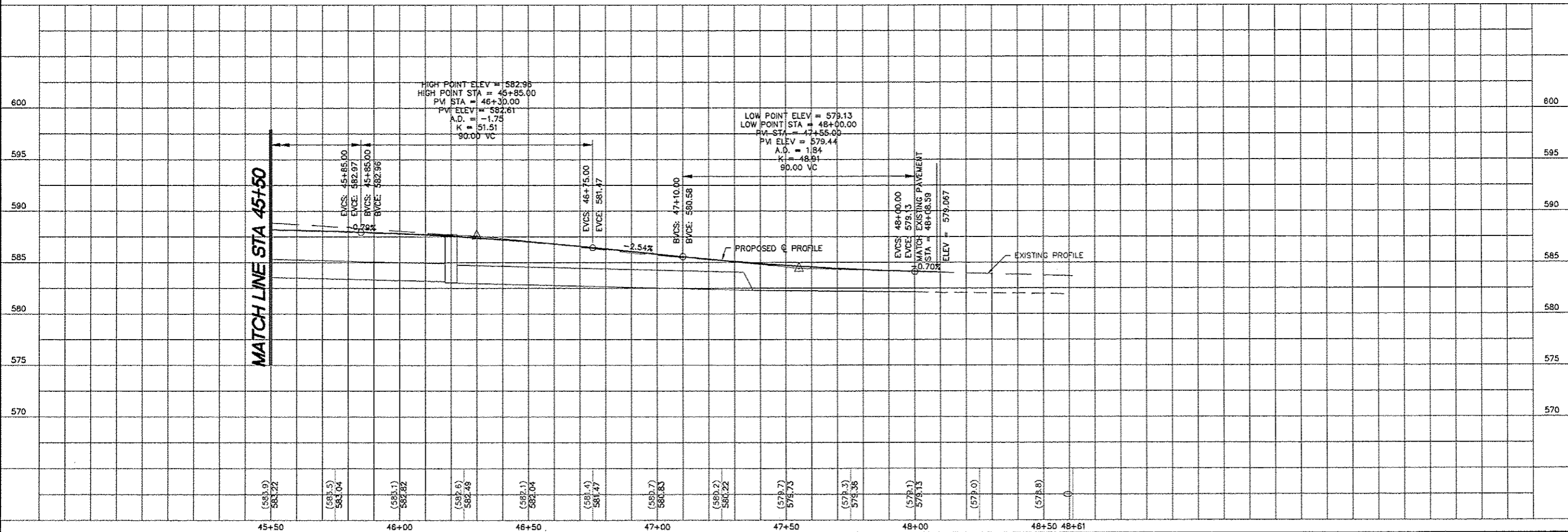

STAMPER LANE - GODFREY, ILLINOIS
FAU ROUTE 8950
10-00022-01-PV
10-00024-00-SW
PLAN AND PROFILE

DWG. NO.	10-00022-01-PV
REF. BK.	PG.
JOB NO.	438439
DSN. BY:	SJW
DWN. BY:	BCS
CHK. BY:	SJW
DATE:	MARCH, 2013
HORT:	1"=20'
SCALE:	VERT: 1"=5'
SHEET	11 OF 50







500 0 500 1000
SCALE IN FEET



GENERAL NOTES

1. ALL CONSTRUCTION SIGNS SHALL MEET THE REQUIREMENTS OF THE LATEST EDITION OF THE "MANUAL ON UNIFORM TRAFFIC CONTROL DEVICES FOR STREETS AND HIGHWAYS"

LEGEND

-  DETOUR ROUTE
-  WORK AREA
-  BLACK ARROW ON ORANGE BACKGROUND
-  ROAD CLOSED AHEAD (W20-3(0)-48)
-  ROAD CONSTRUCTION AHEAD (W20-1(0)-48)
-  48" X 48" SIGN (FLUORESCENT) (WITH TYPE A MONODIRECTIONAL FLASHING AMBER LIGHT)

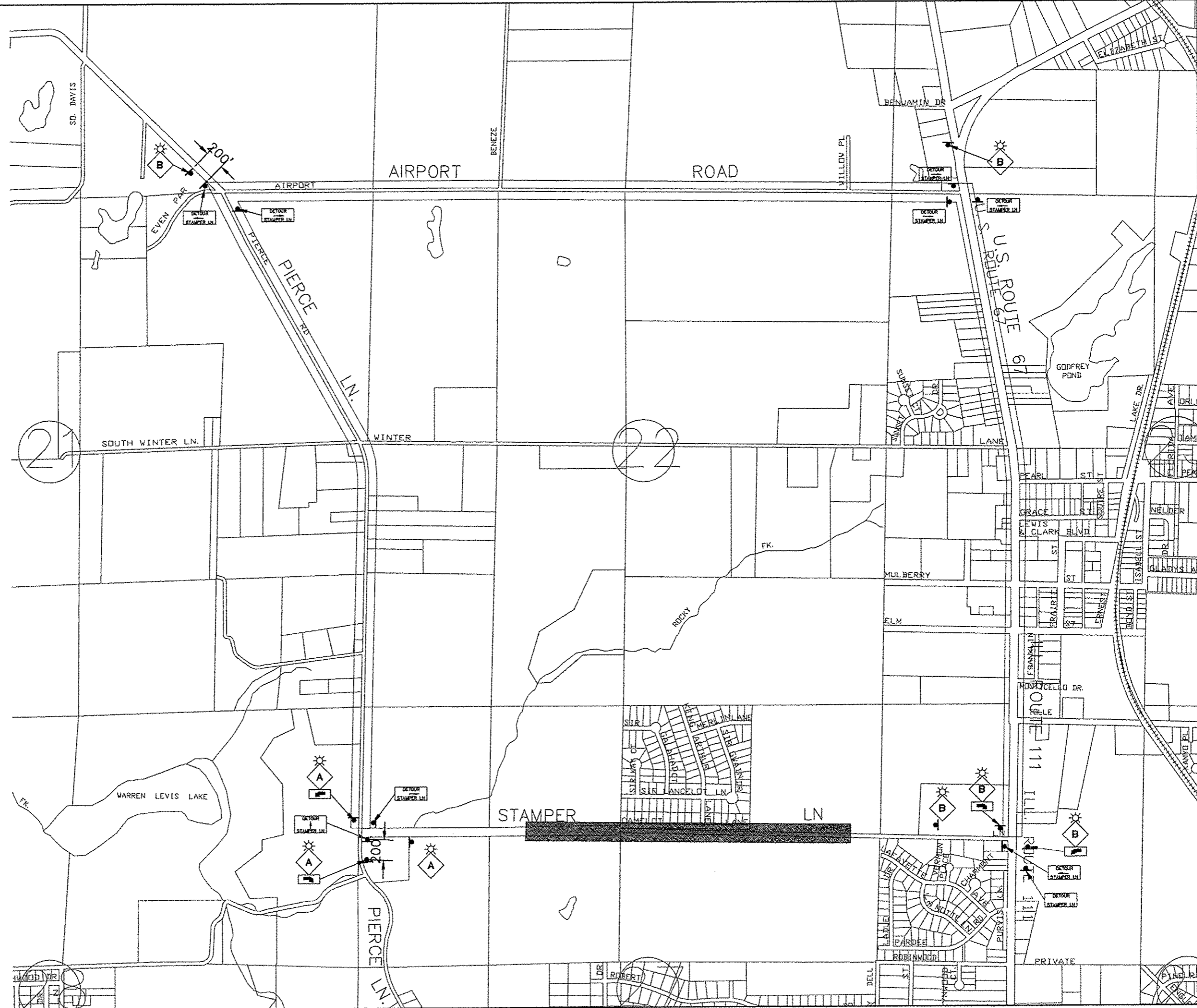

REVISIONS







SMS ENGINEERS
 Sheppard, Morgan & Schwaab, Inc.
 CONSULTING ENGINEERS AND LAND SURVEYORS
 215 North Street, P.O. Box E, Atton, IL 62202 618-462-2755 E-mail: mail@smseng.com
 10 Central Industrial Drive, Suite 1, Great Oak, IL 60137 630-613-7700 E-mail: mail@mseng.com
 DESIGN FIRM # 184-000992

STAMPER LANE - GODFREY, ILLINOIS
 FAU ROUTE 8950
 10-00022-01-PV
 10-00024-00-SW
 TRAFFIC DETOUR PLAN

DWG. NO.	
REF. BK.	PG.
JOB NO.	438439
DSN. BY:	SW
OWN. BY:	BCS
CHK. BY:	SW
DATE:	MARCH, 2013
SCALE:	1"=500'
SHEET	12 OF 50



LEGEND

-  INLET AND PIPE PROTECTION
-  PERIMETER EROSION BARRIER
-  EROSION CONTROL BLANKET
-  SEDIMENT BASIN
-  TEMPORARY DITCH CHECK
-  INLET FILTERS

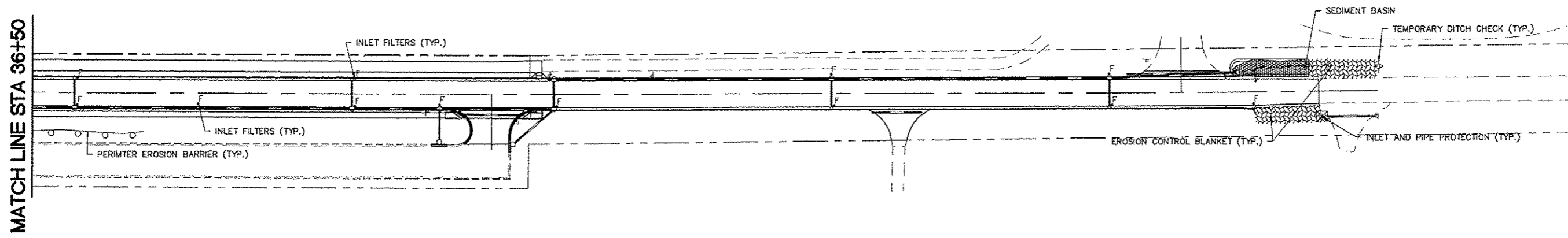
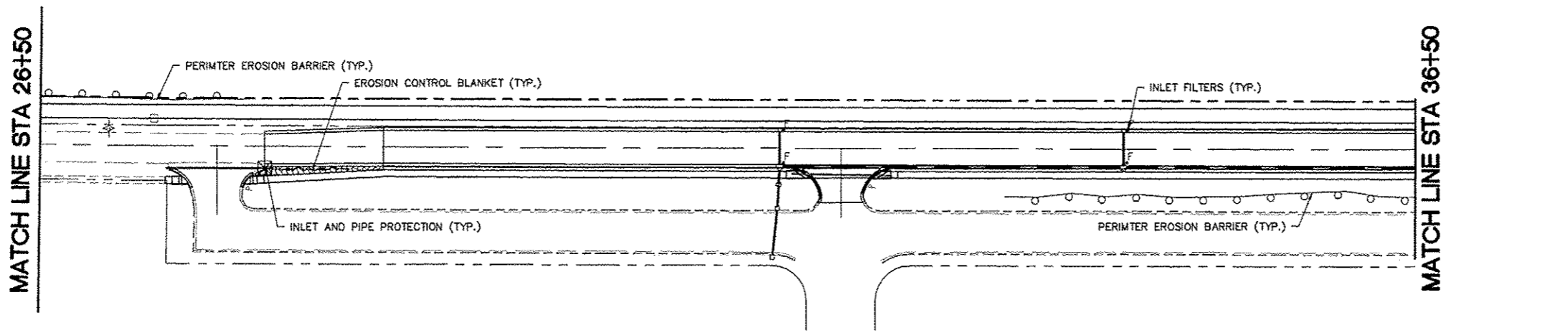
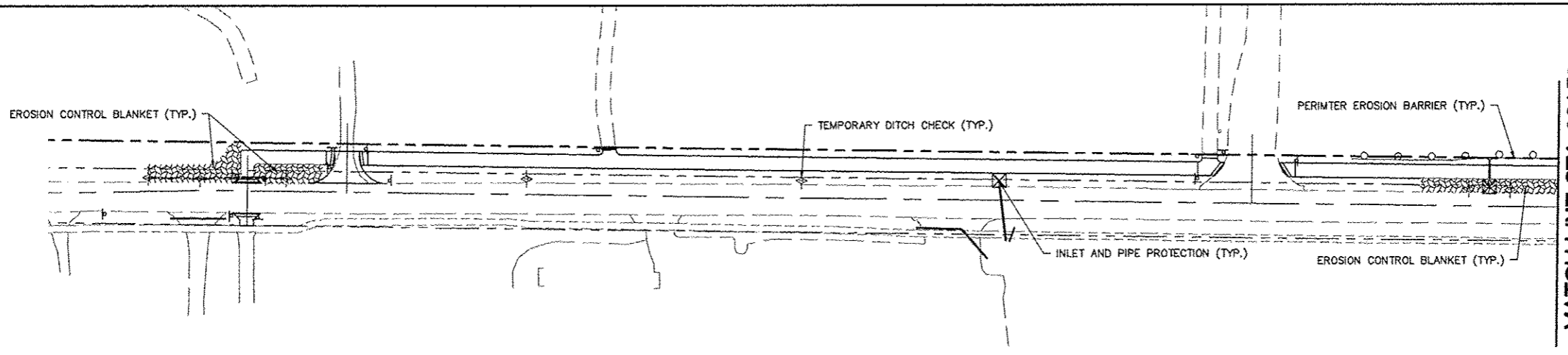

EROSION CONTROL QUANTITIES

		SRTS	STU	TOTAL
SEEDING, CLASS 1B	ACRE	0.5	2.5	3
NITROGEN FERTILIZER NUTRIENT	POUND	50	250	300
PHOSPHORUS FERTILIZER NUTRIENT	POUND	50	250	300
POTASSIUM FERTILIZER NUTRIENT	POUND	50	250	300
AGRICULTURAL GROUND LIMESTONE	TON	1	5	6
MULCH, METHOD 2	ACRE	0.5	2.5	3
EROSION CONTROL BLANKET	SQ YD	500	300	800
EARTH EXCAVATION FOR EROSION CONTROL	CU YD	50	100	150
TEMPORARY EROSION CONTROL SEEDING	POUND	50	250	300
TEMPORARY DITCH CHECKS	FOOT	80	30	110
PERIMETER EROSION BARRIER	FOOT	300	400	700
INLET AND PIPE PROTECTION	EACH	2	2	4
INLET FILTERS	EACH	0	20	20

EROSION CONTROL NOTES

1. ALL EROSION CONTROL WORK SHALL BE PERFORMED IN ACCORDANCE WITH SECTION 280 OF THE STANDARD SPECIFICATIONS AND HIGHWAY STANDARD 280001.
2. THIS PLAN SHOWS GENERAL LAYOUT OF EROSION CONTROL ITEMS. ACTUAL PLACEMENT AND LOCATIONS OF EROSION CONTROL ITEMS SHALL BE AS DIRECTED BY THE ENGINEER.
3. THE SEDIMENT BASINS SHOWN ON THE PLANS ARE TO BE CONSTRUCTED TO THE DIMENSIONS AND LOCATIONS CORRESPONDING WITH THE RIPRAP INSTALLATION. THE SEDIMENT BASINS SHALL REMAIN IN PLACE AND BE MAINTAINED UNTIL FINAL INSTALLATION OF RIPRAP IS AUTHORIZED BY THE ENGINEER.
4. THE ITEMS EXCAVATION FOR EROSION CONTROL AND TEMPORARY EROSION CONTROL SEEDING ARE INCLUDED IN THE CONTRACT FOR EROSION CONTROL PURPOSES. THESE ITEMS SHALL ONLY BE USED ON THOSE OCCASIONS WHEN THE CONTRACTOR IS DIRECTED BY THE ENGINEER.
5. A STORM WATER POLLUTION PREVENTION PLAN (SWPPP) IS INCLUDED IN THE PROJECT SPECIFICATIONS. THE CONTRACTOR SHALL ABIDE BY ALL PROVISIONS OF THE SWPPP.

STAMPER LANE - GODFREY, ILLINOIS
FAU ROUTE 8950
10-00022-01-PV
10-00024-00-SW
EROSION CONTROL PLAN

SMS ENGINEERS
 Sheppard, Morgan & Schwaab, Inc.
 CONSULTING ENGINEERS AND LAND SURVEYORS
 270 North Street, P.O. Box E, Abax, IL 62002 618-662-3755 E-mail: info@smsengineers.com
 17 Central Expressway, Suite 21, Granite City, IL 62040 618-377-9010 E-mail: info@smsengineers.com
 DESIGN FIRM # 184-000992

DWG. NO.	
DATE	10/20/2010
REV. NO.	01
REV. DATE	10/20/2010
REV. BY	BCS
REV. CHECKED BY	SJW
DATE	MARCH, 2013
SCALE	1"=50'
SHEET	14 OF 50

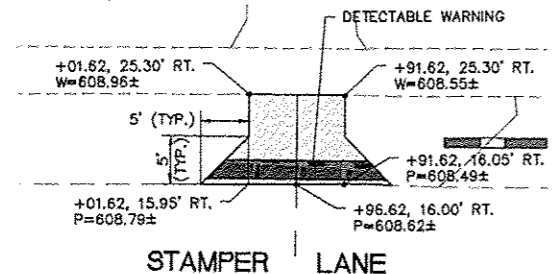

STAMPER LANE

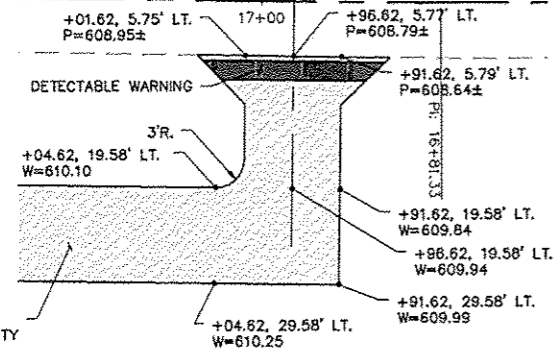

BIKE TRAIL CROSSING DETAIL #1

1"=10'

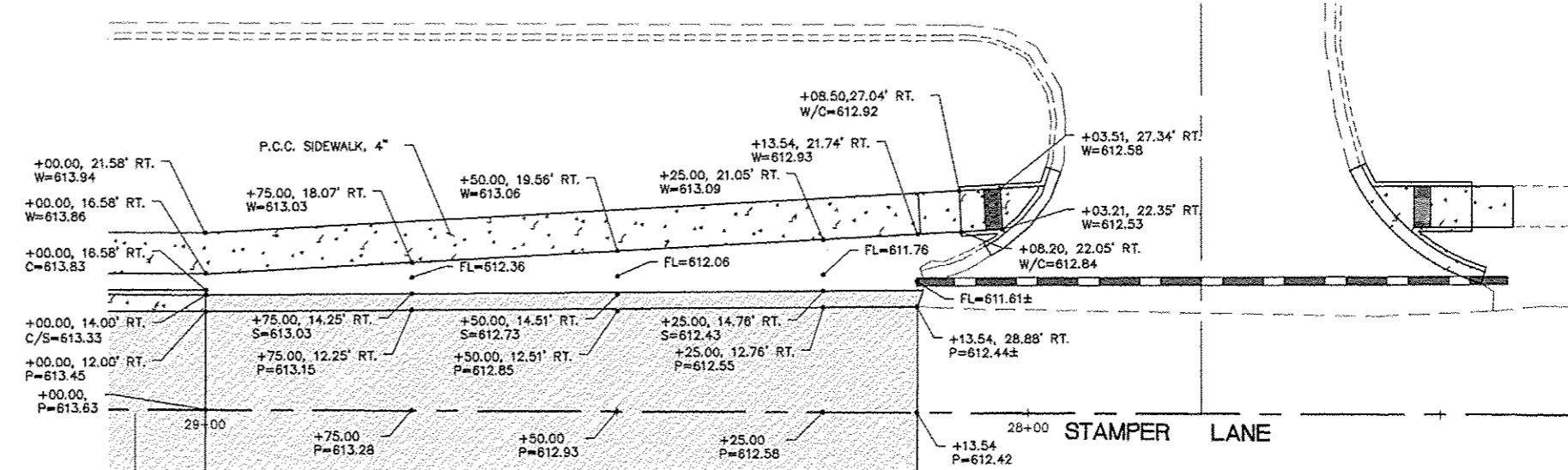

CAMELOT ENTRANCE DETAIL #1

1"=10'

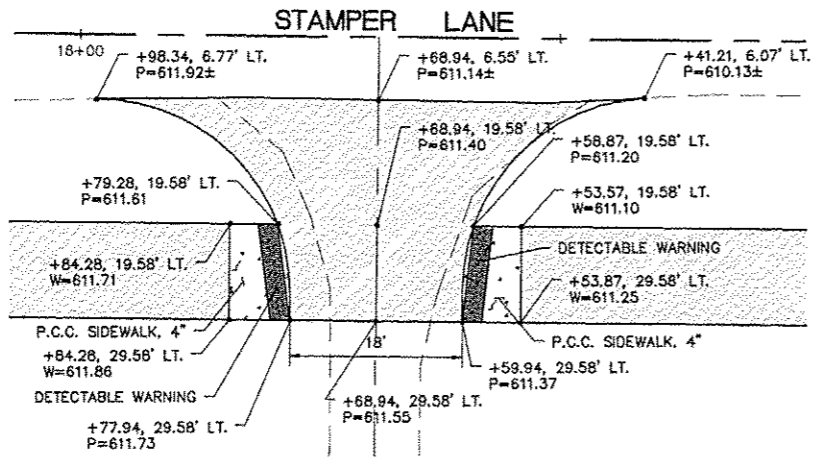

BIKE TRAIL CROSSING DETAIL #2

1"=10'

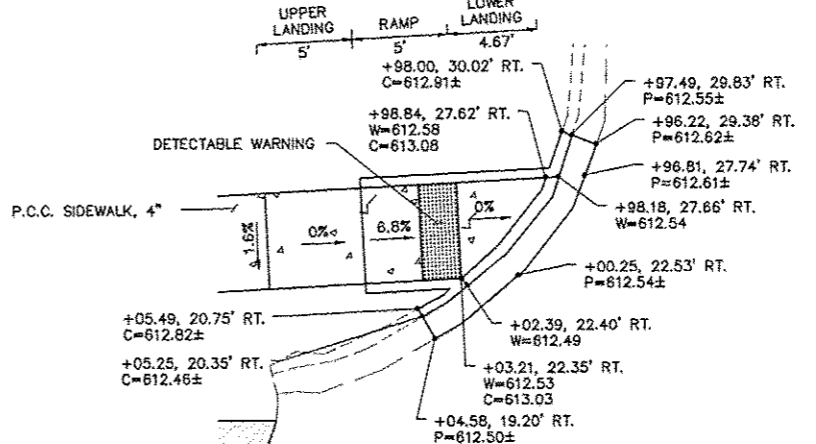

CAMELOT ENTRANCE DETAIL #2

CURB RAMP NW

1"=5'

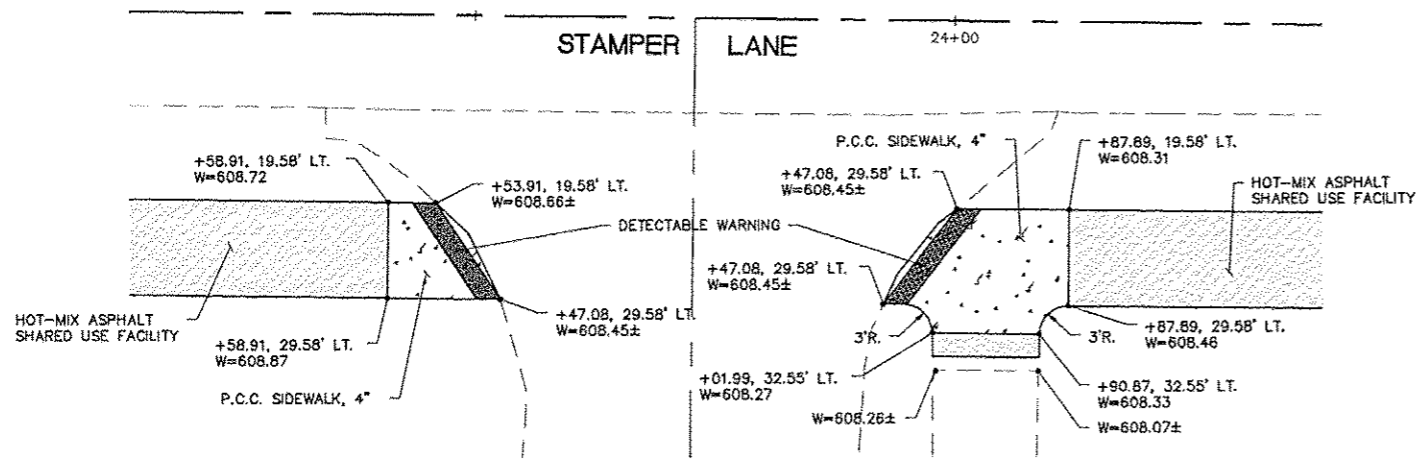

BIKE TRAIL CROSSING DETAIL #3

1"=10'

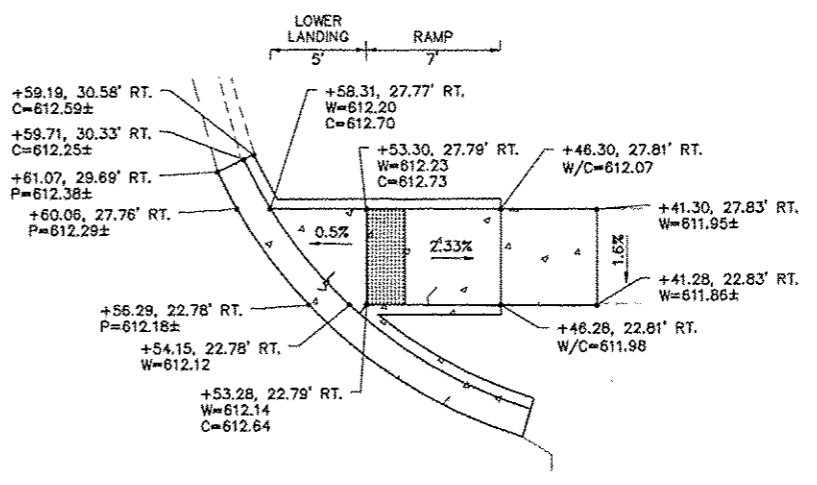

CAMELOT ENTRANCE DETAIL #3

CURB RAMP NE

1"=5'

REVISIONS

Sheppard, Morgan & Schwaab, Inc.
 CONSULTING ENGINEERS AND LAND SURVEYORS
 219 Market Street, P.O. Box E, Alton, IL 62002 618/462-9752 E-mail: sm&s@smengineers.com
 10 Central Industrial Drive, Suite 3, Granite City, IL 62040 618/977-5700 E-mail: realign@smengineers.com
 DESIGN FIRM # 184-000992



STAMPER LANE - GODFREY, ILLINOIS
 FAU ROUTE 8950
 10-00022-01-PV
 10-00024-00-SW
 INTERSECTION AND RAMP DETAILS

DWG. NO.	
PROJ. NO.	
REF. B/C	
JOB NO.	438439
DSN. BY:	SJW
DWN. BY:	BCS
CHK. BY:	SJW
DATE:	MARCH, 2013
SCALE:	AS SHOWN
SHEET	15 OF 50

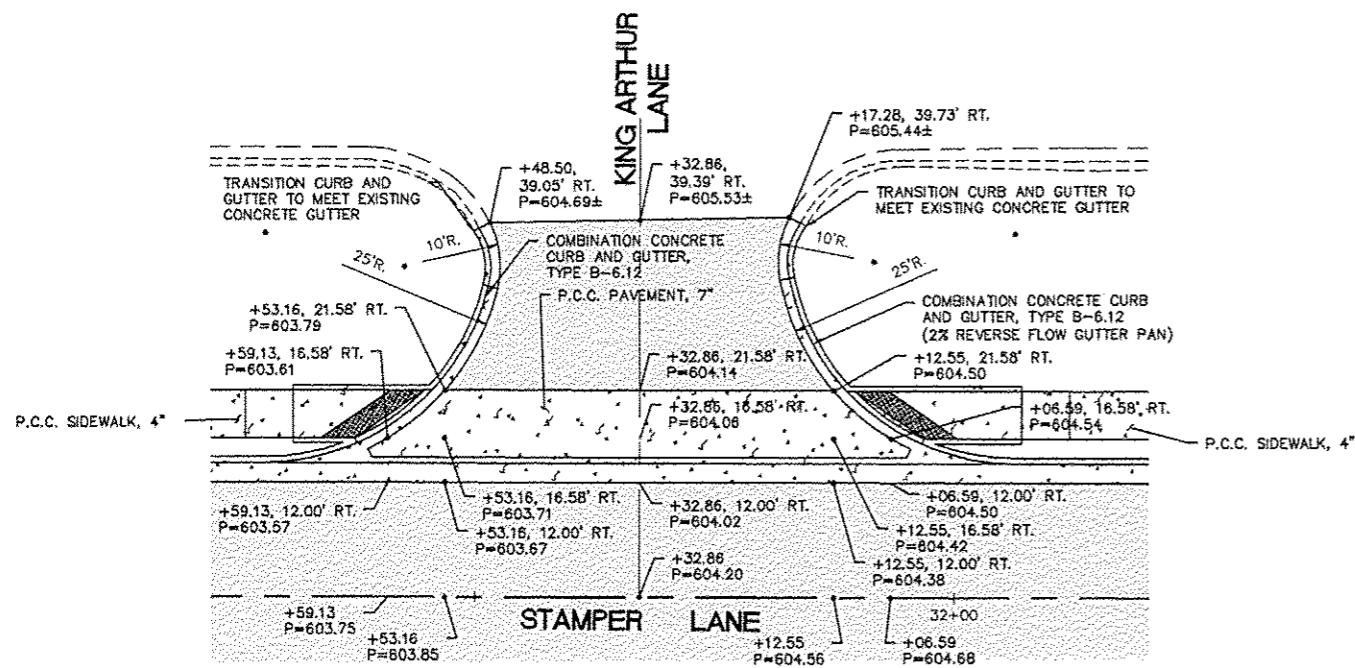

KING ARTHUR LANE ENTRANCE DETAIL #1
1"=10'

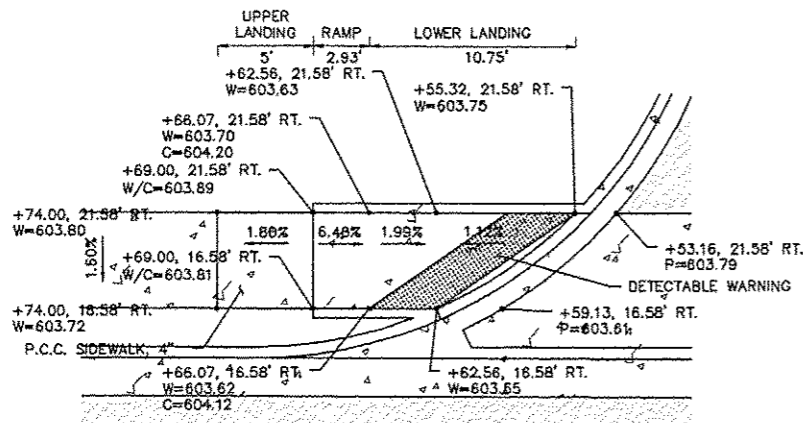

KING ARTHUR LANE ENTRANCE DETAIL #2
CURB RAMP NW
1"=5'

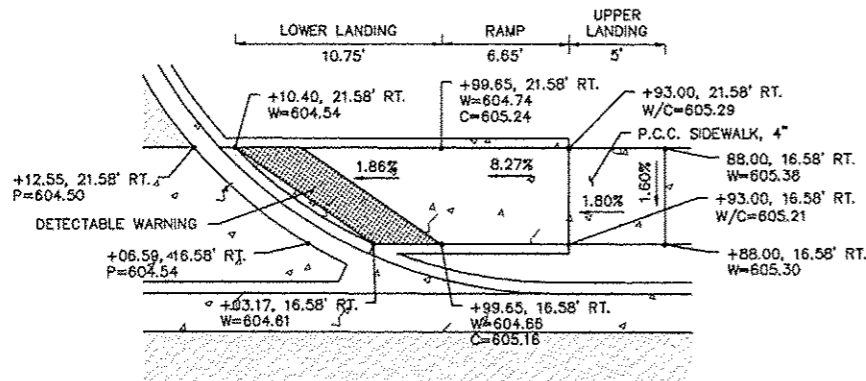

KING ARTHUR LANE ENTRANCE DETAIL #3
CURB RAMP NE
1"=5'

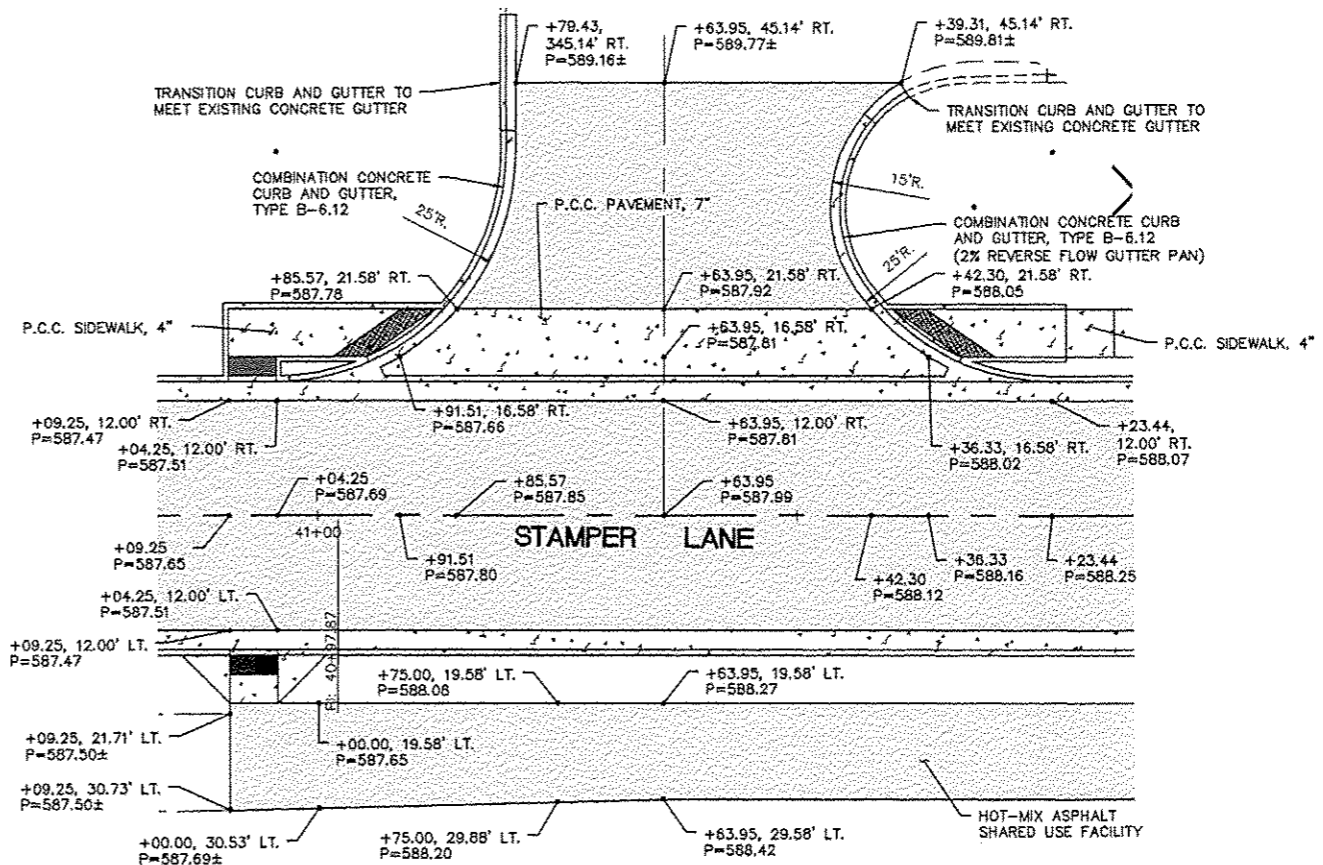

CAMELOT ENTRANCE DETAIL #4
1"=10'

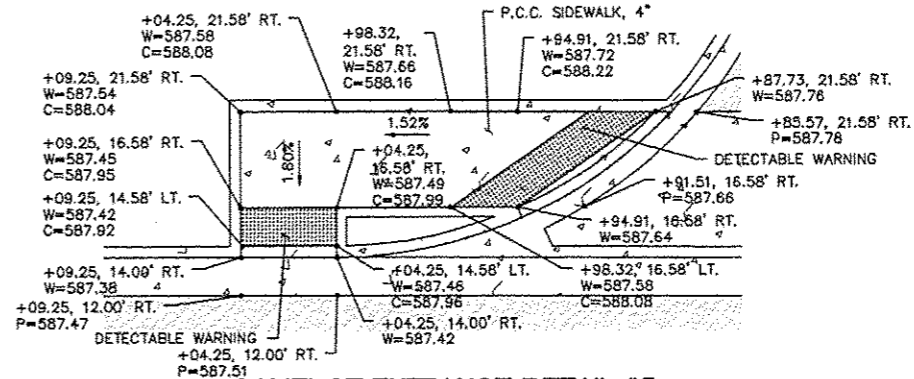

CAMELOT ENTRANCE DETAIL #5
CURB RAMP NW
1"=5'

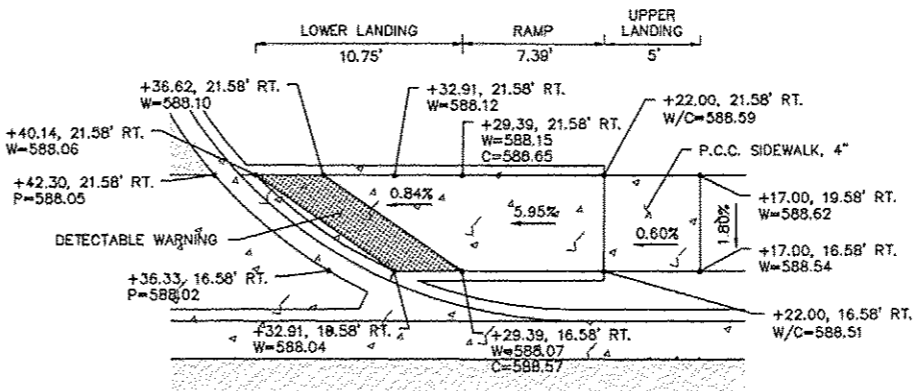

CAMELOT ENTRANCE DETAIL #6
CURB RAMP NE
1"=5'

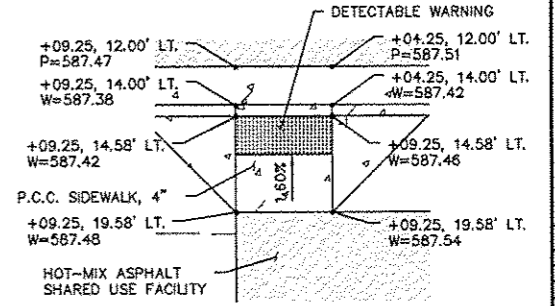

CAMELOT ENTRANCE DETAIL #7
CURB RAMP SW
1"=5'

REVISIONS

SMS ENGINEERS
Sheppard, Morgan & Schwaab, Inc.
CONSULTING ENGINEERS AND LAND SURVEYORS
215 Market Street, P.O. Box E, Ann Arbor, MI 48106-0215 Email: sm@smengineers.com
10 Central Expressway, Suite 3, Grand Crag, IL 60130-1200 Email: toll@smengineers.com
DESIGN FIRM # 184-000992

STAMPER LANE - GODFREY, ILLINOIS
FAU ROUTE 8950
10-00022-01-PV
10-00024-00-SW
INTERSECTION AND RAMP DETAILS

DWG. NO.	
DATE	MARCH, 2013
SCALE	AS SHOWN
SHEET	18 OF 50

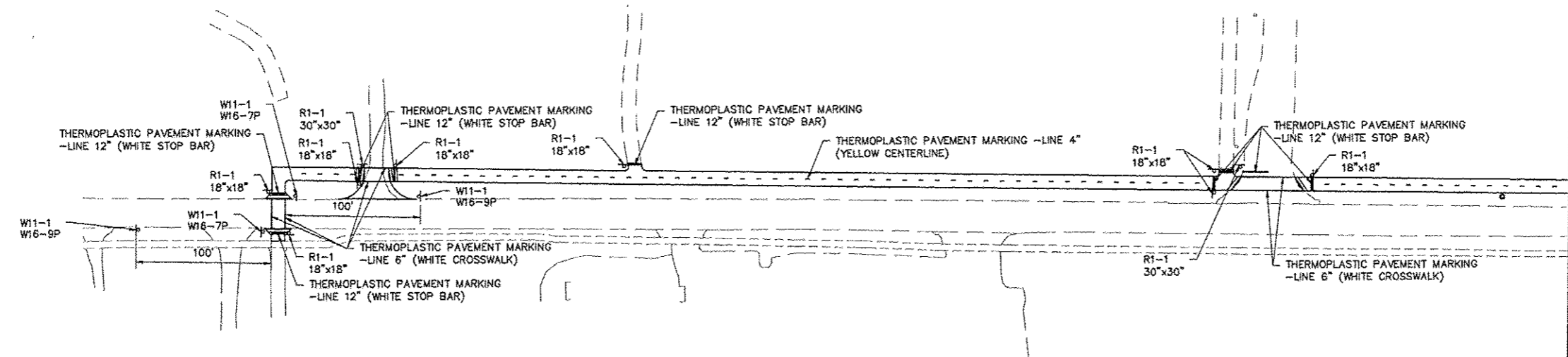

MATCH LINE STA 26+50

MATCH LINE STA 26+50

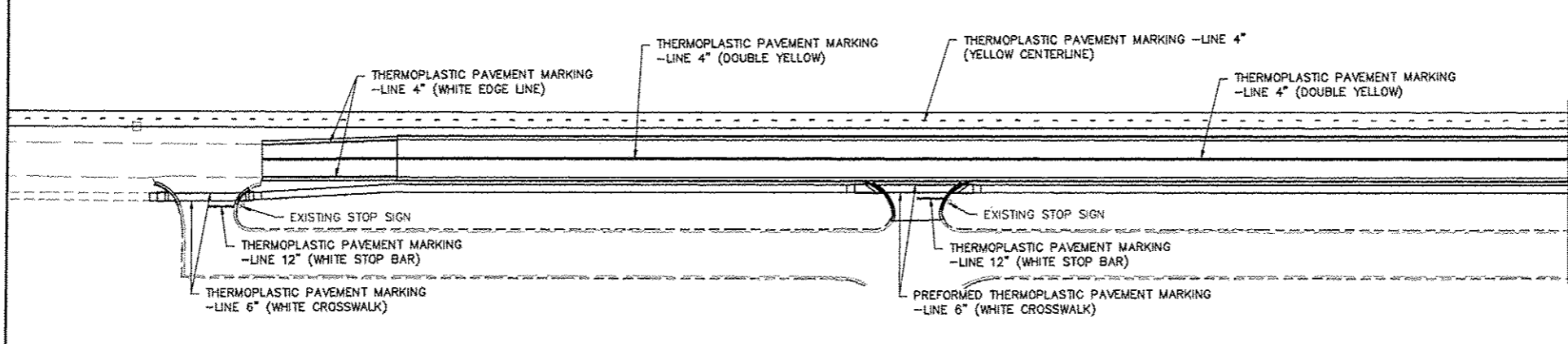

MATCH LINE STA 36+50

MATCH LINE STA 36+50

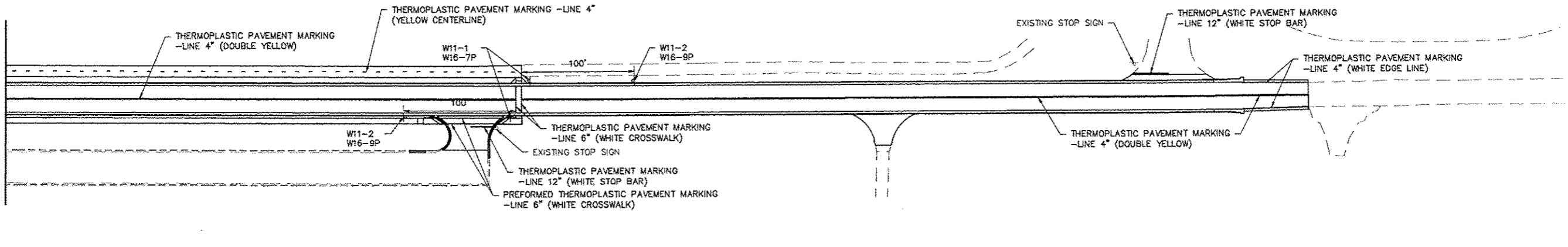

PAVEMENT MARKING QUANTITIES

	SQ. FT.	SRTS	STU	TOTAL
SIGN PANEL - TYPE 1		71	24	95
METAL POST - TYPE B	FOOT	215	60	275
THERMOPLASTIC PAVEMENT MARKING - LINE 4"	FOOT	600	3800	4400
THERMOPLASTIC PAVEMENT MARKING - LINE 6"	FOOT	180	130	310
THERMOPLASTIC PAVEMENT MARKING - LINE 12"	FOOT	60	90	150
PREFORMED THERMOPLASTIC PAVEMENT MARKING - LINE 6"	FOOT	0	100	100



R1-1
18"x18"



W11-1
24"x24"



W11-2
24"x24"



W16-9P
24"x12"



W16-7P
24"x12"

REVISIONS

SMS ENGINEERS
 Sheppard, Morgan & Schwaab, Inc.
 CONSULTING ENGINEERS AND LAND SURVEYORS
 210 North Street, P.O. Box E, Alton, IL 60202 618-662-9755 Email: ralph@smsengineers.com
 10 Canal Street, Suite 2, Granite City, IL 62040 618-771-5700 Email: tracy@smsengineers.com
 DESIGN FIRM # 184-000992

STAMPER LANE - GODFREY, ILLINOIS
 FAU ROUTE 8950
 10-00022-01-PV
 10-00024-00-SW
 PAVEMENT MARKING PLAN

DWG. NO. 10-00022-01-PV
 PROJ. DIMS STAMPER IN FAU PAV MARKING PLAN
 REF. BK. PG.
 JOB NO. 438439
 DSN. BY: SJW
 DWN. BY: BCS
 CHK. BY: SJW
 DATE: MARCH, 2013
 SCALE: 1"=50'
 SHEET 17 OF 50

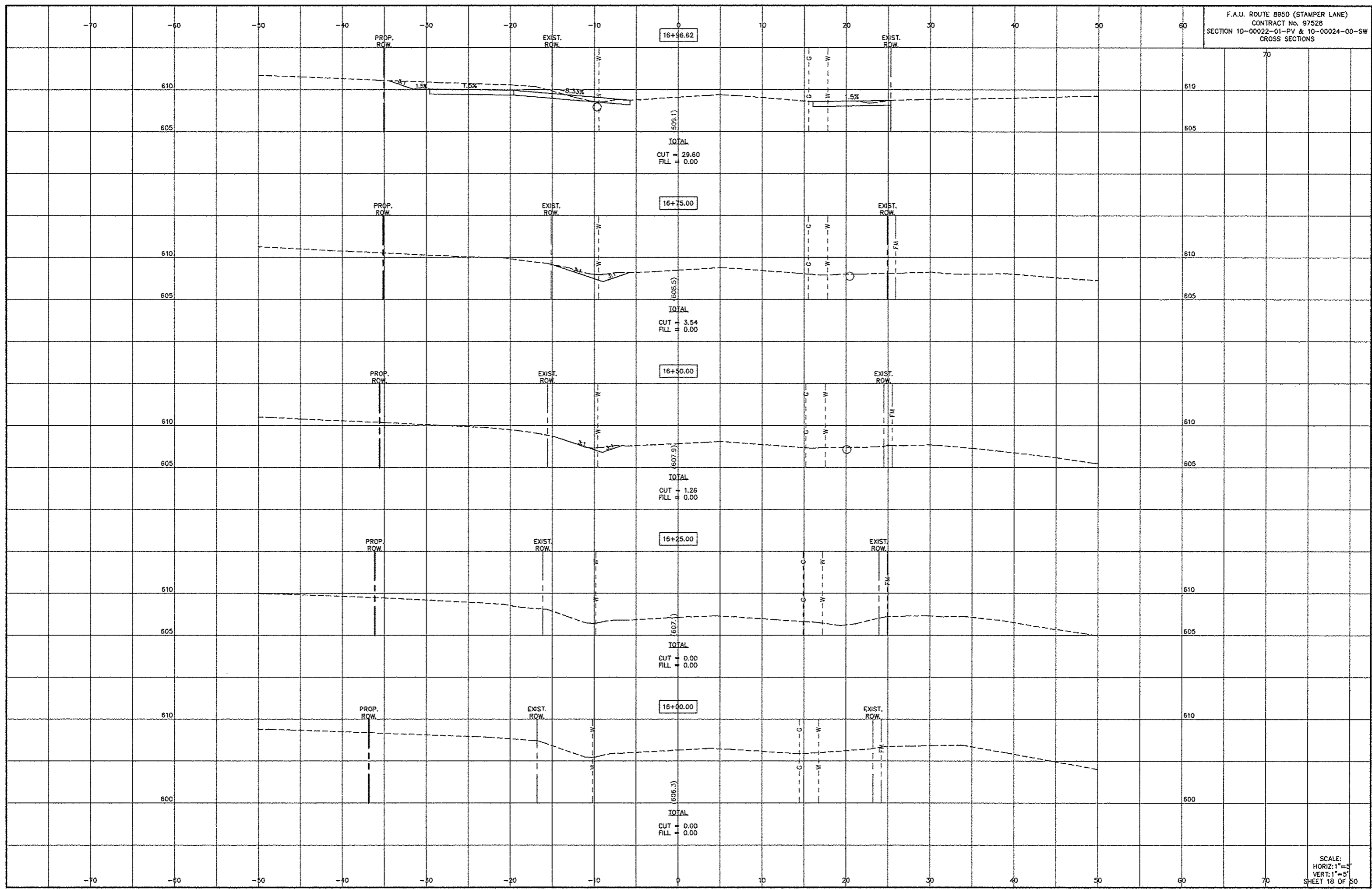

SCALE:
 HORIZ: 1"=5'
 VERT: 1"=5'

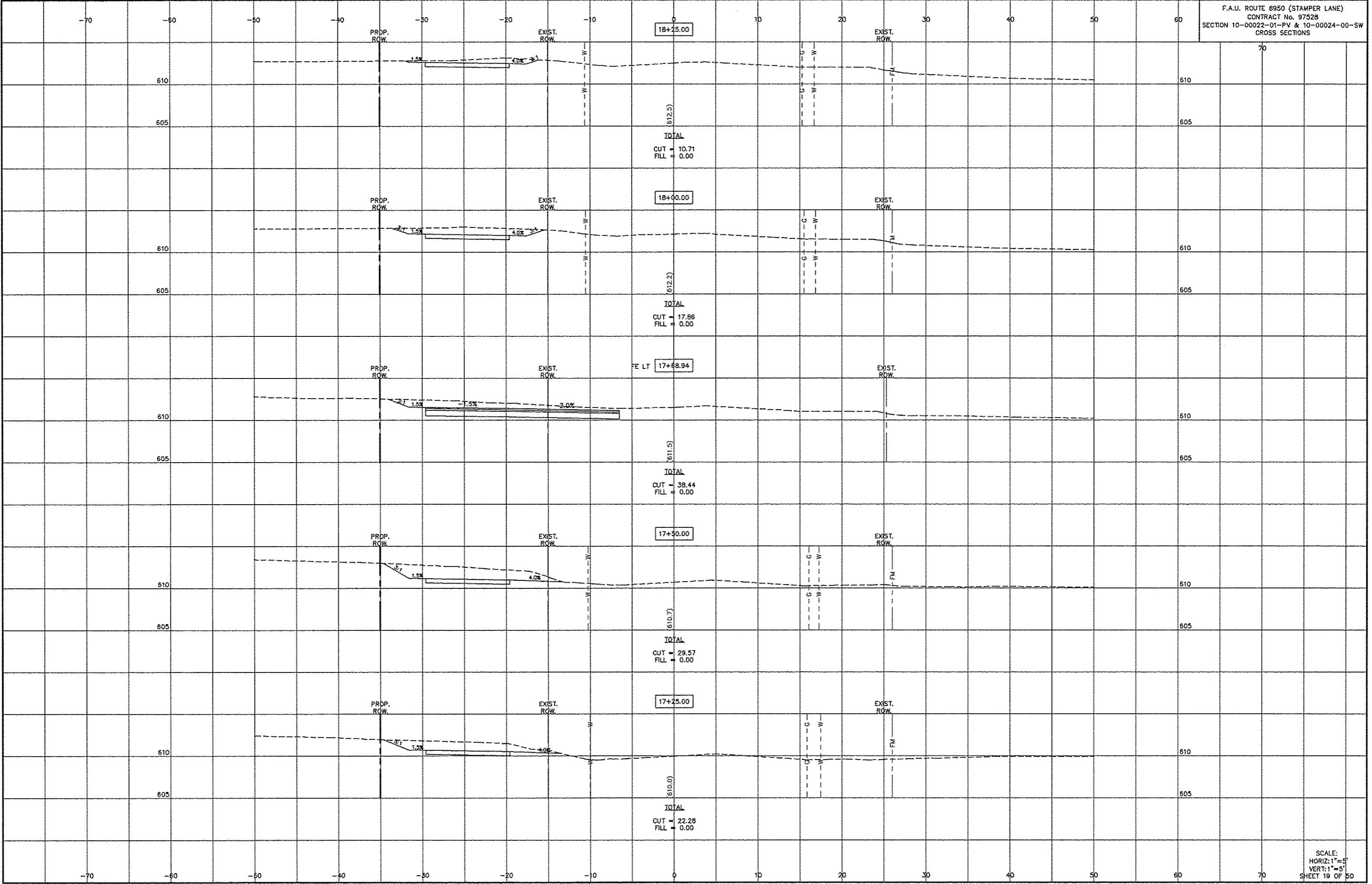

SCALE:
 HORIZ: 1"=5'
 VERT: 1"=5'

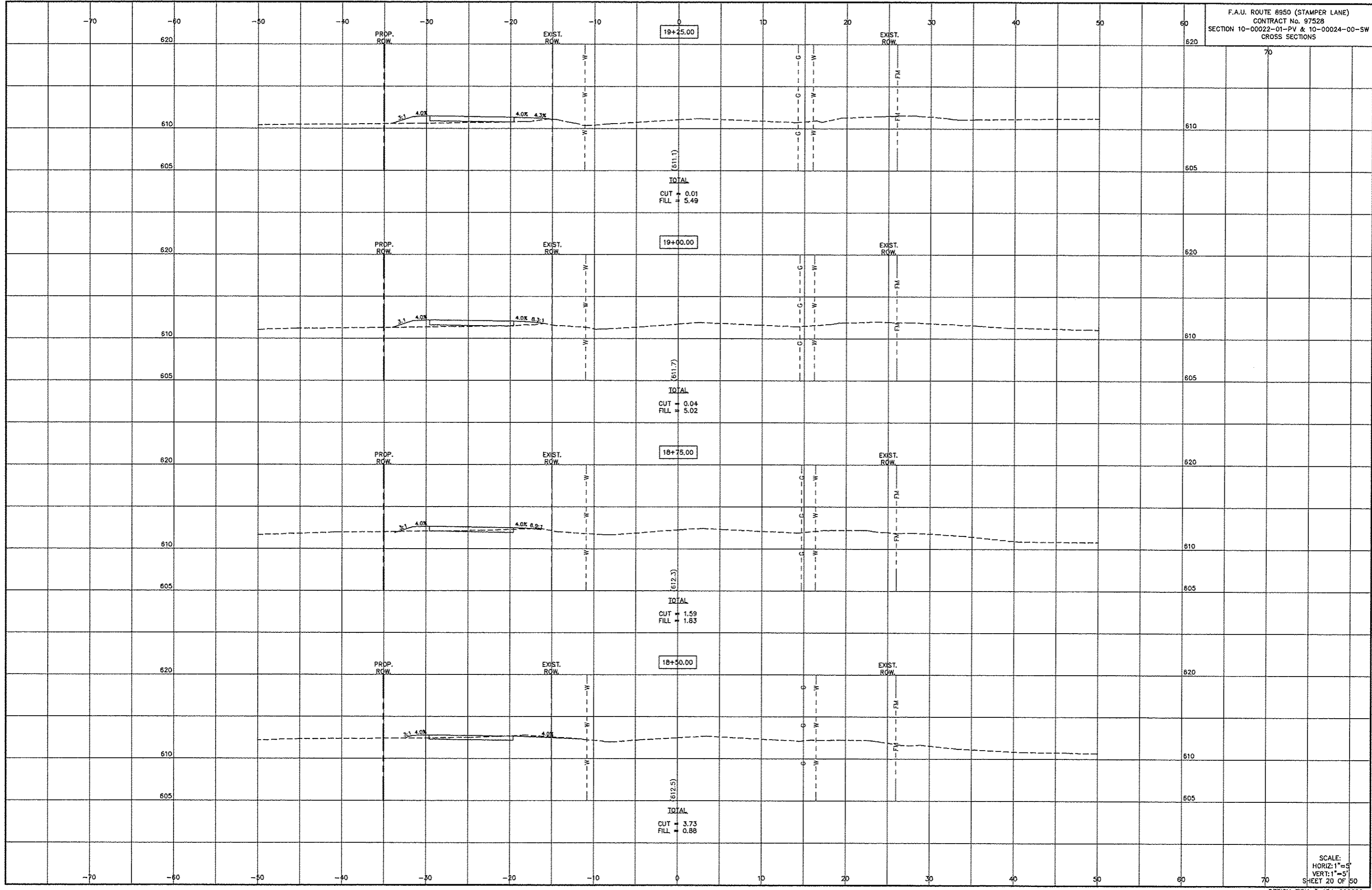

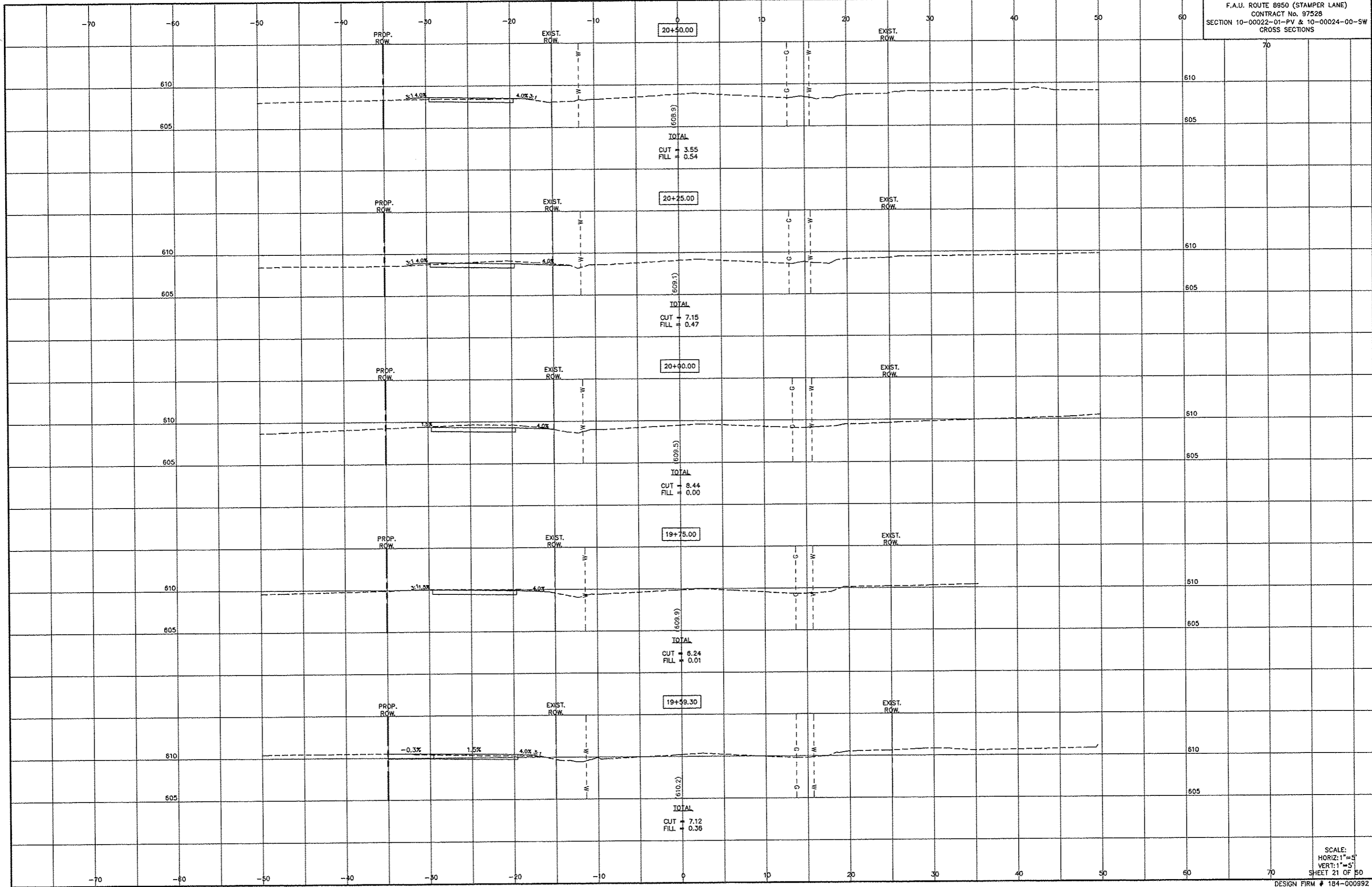

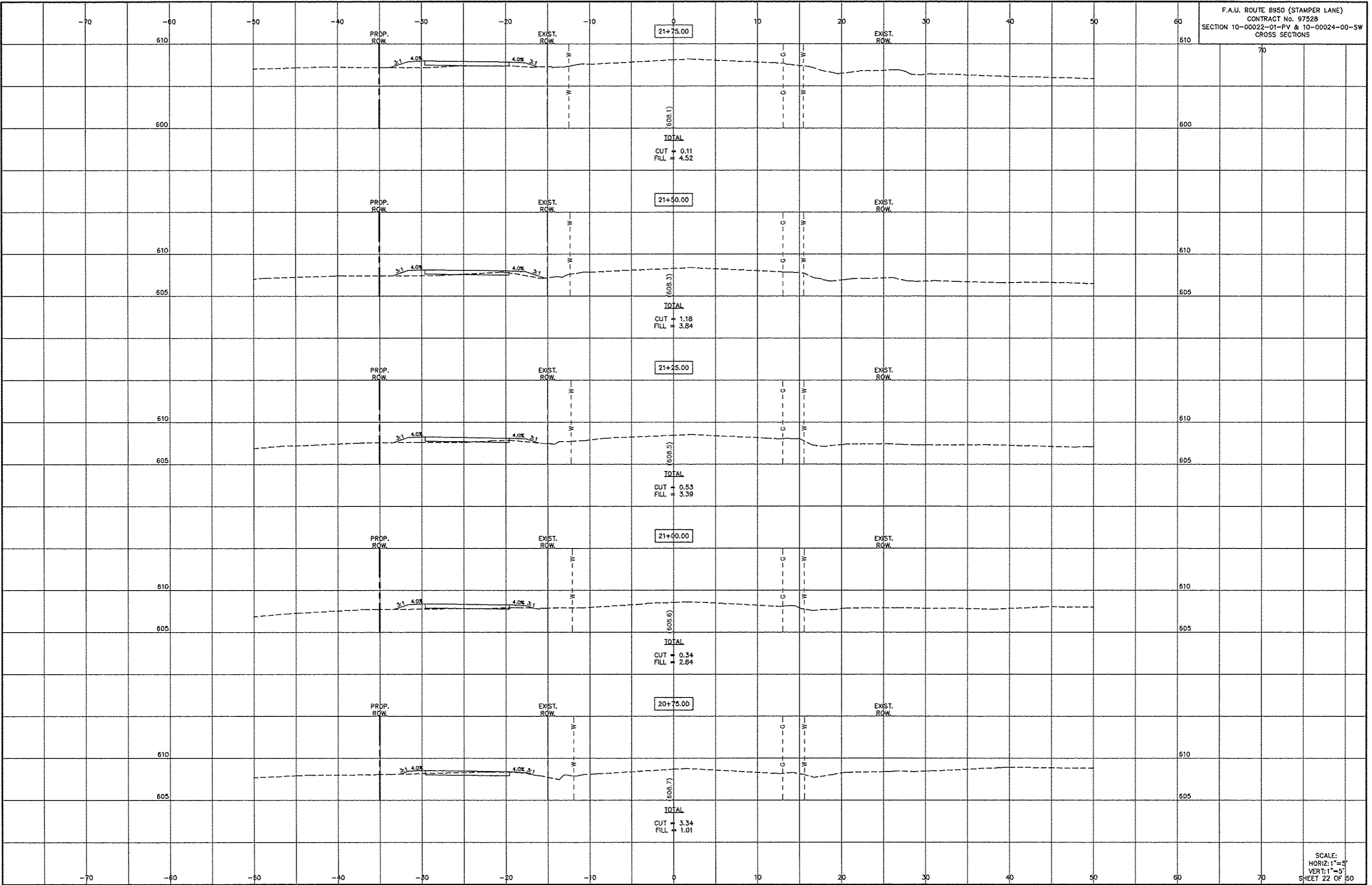

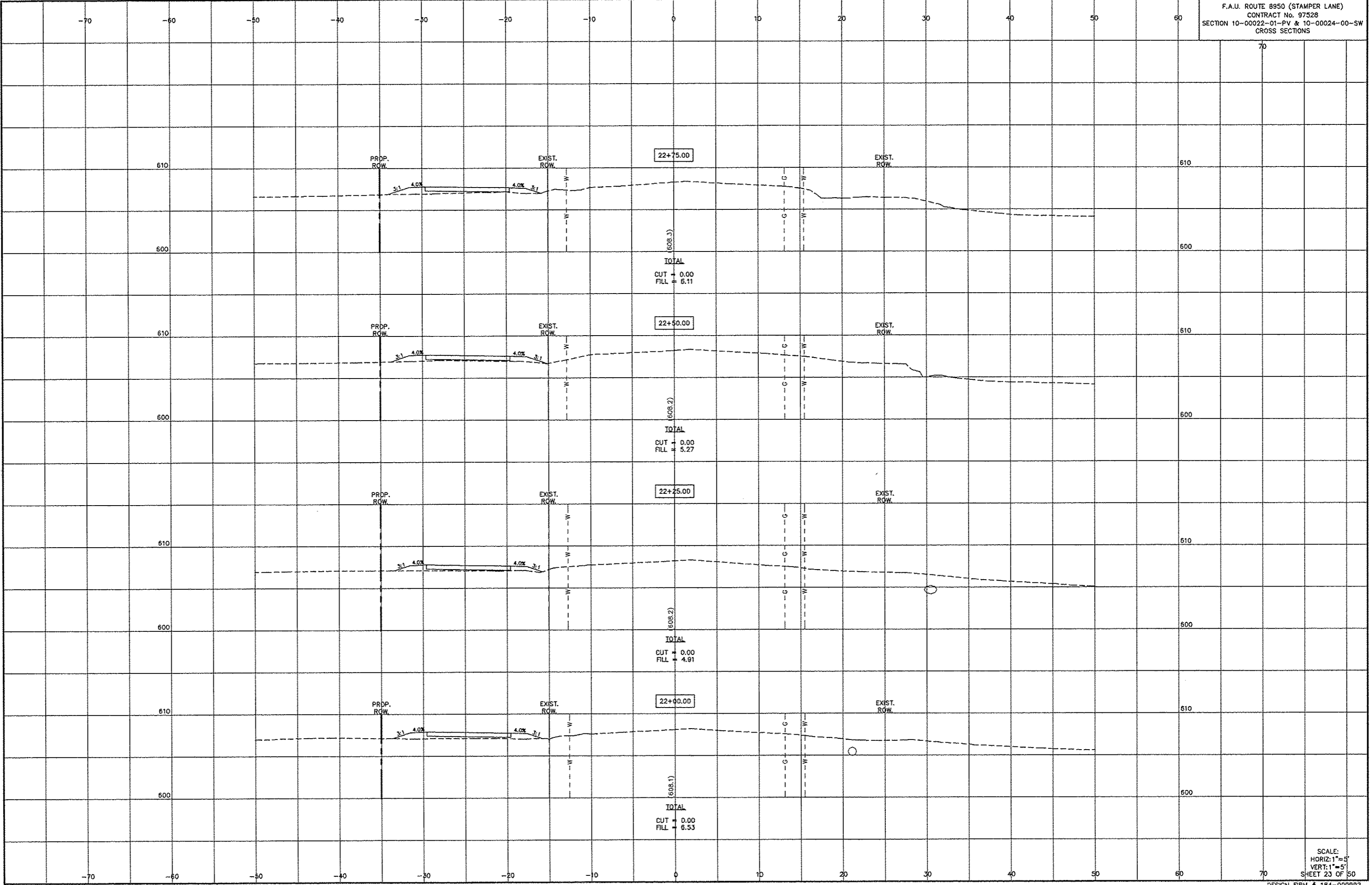

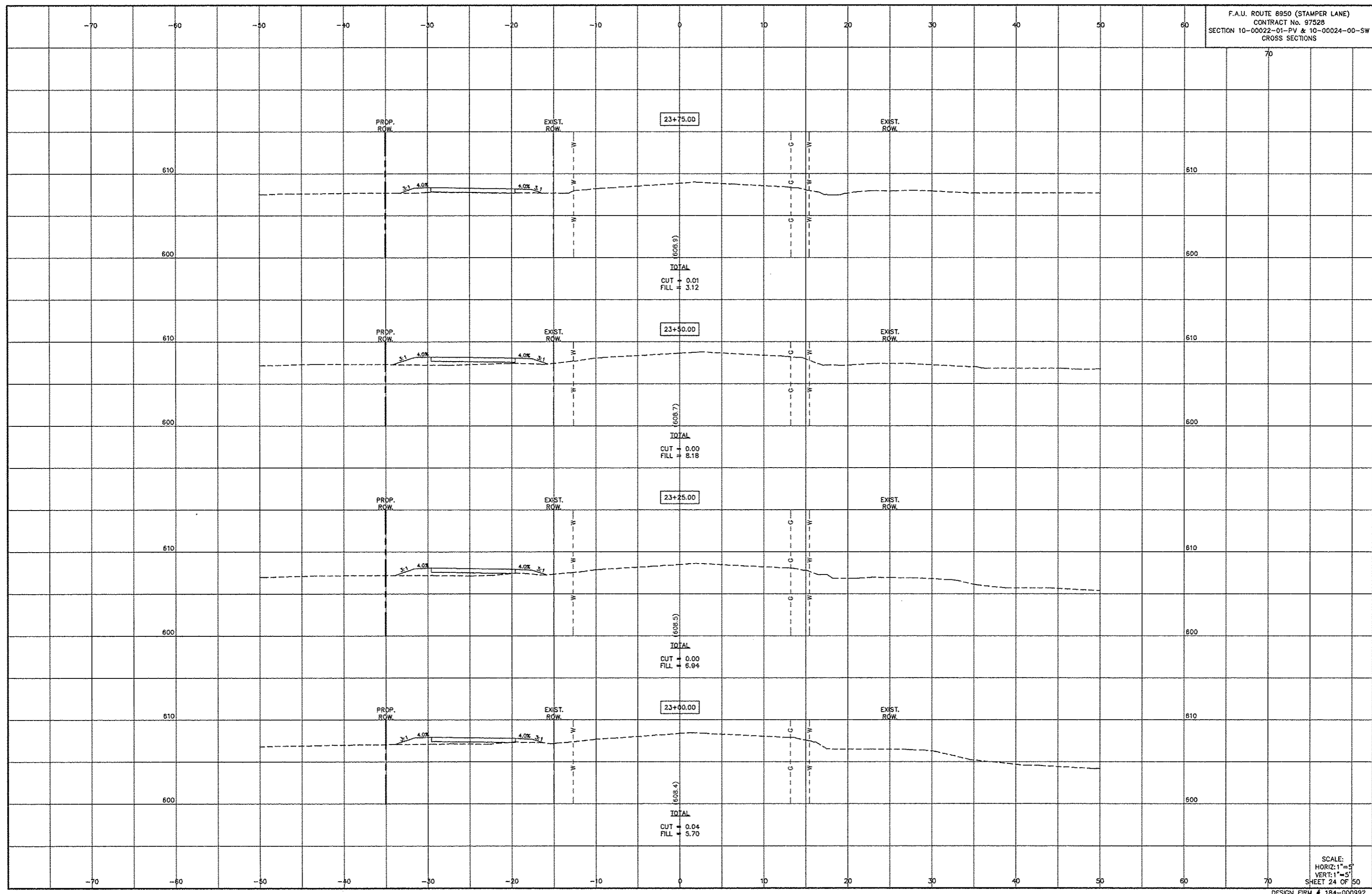

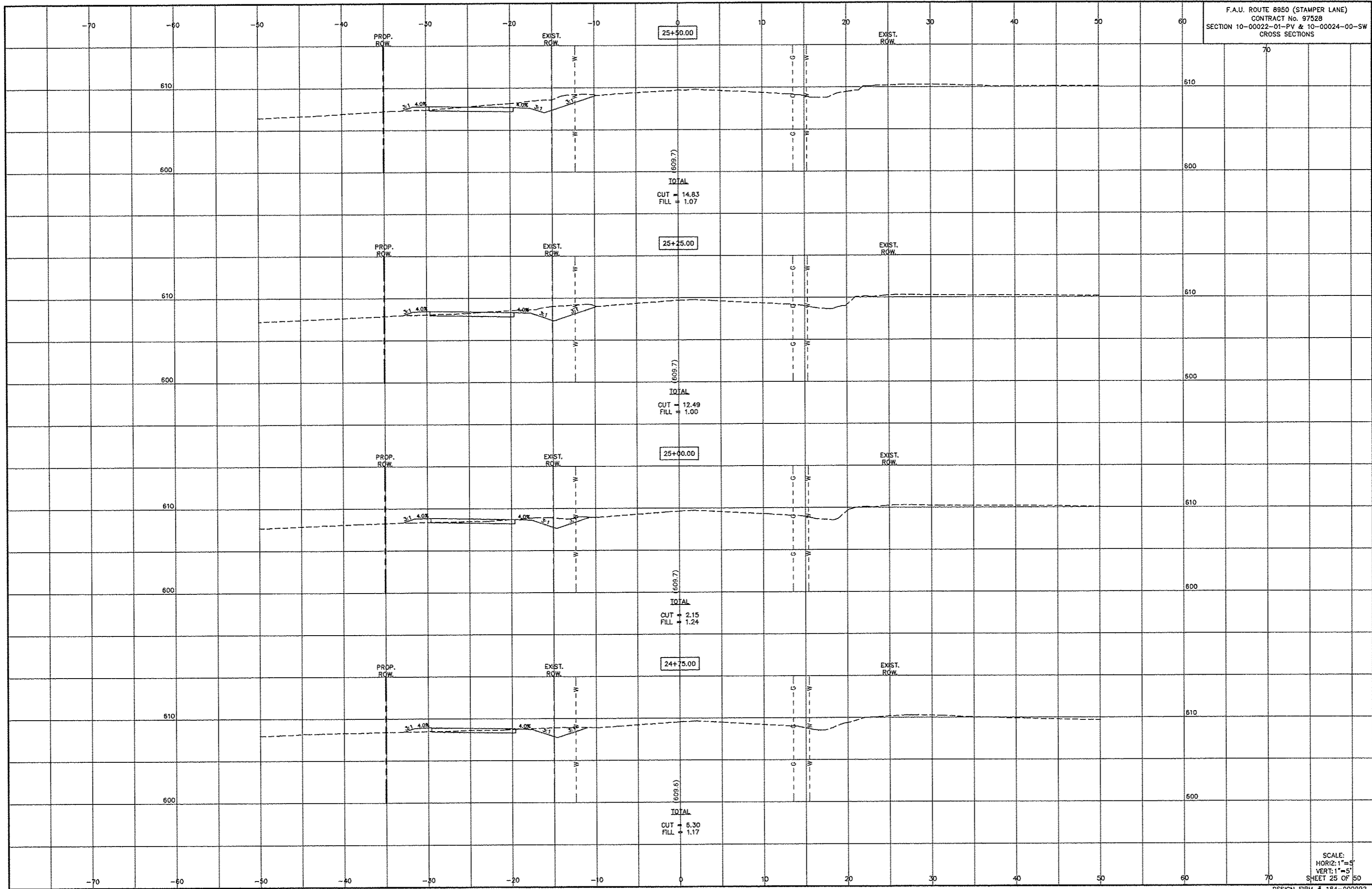

SCALE:
 HORIZ: 1"=5'
 VERT: 1"=5'
 SHEET 25 OF 50

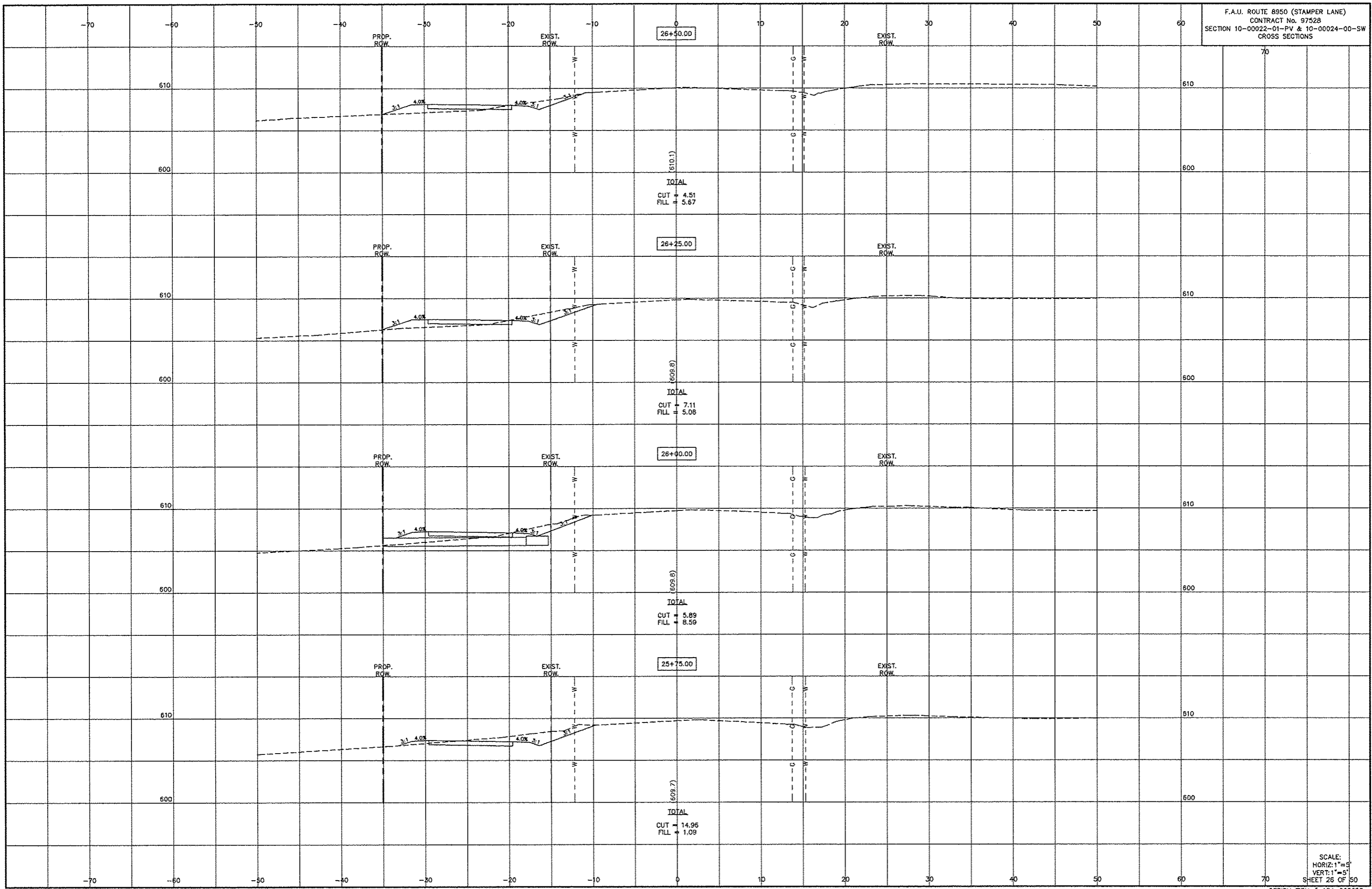

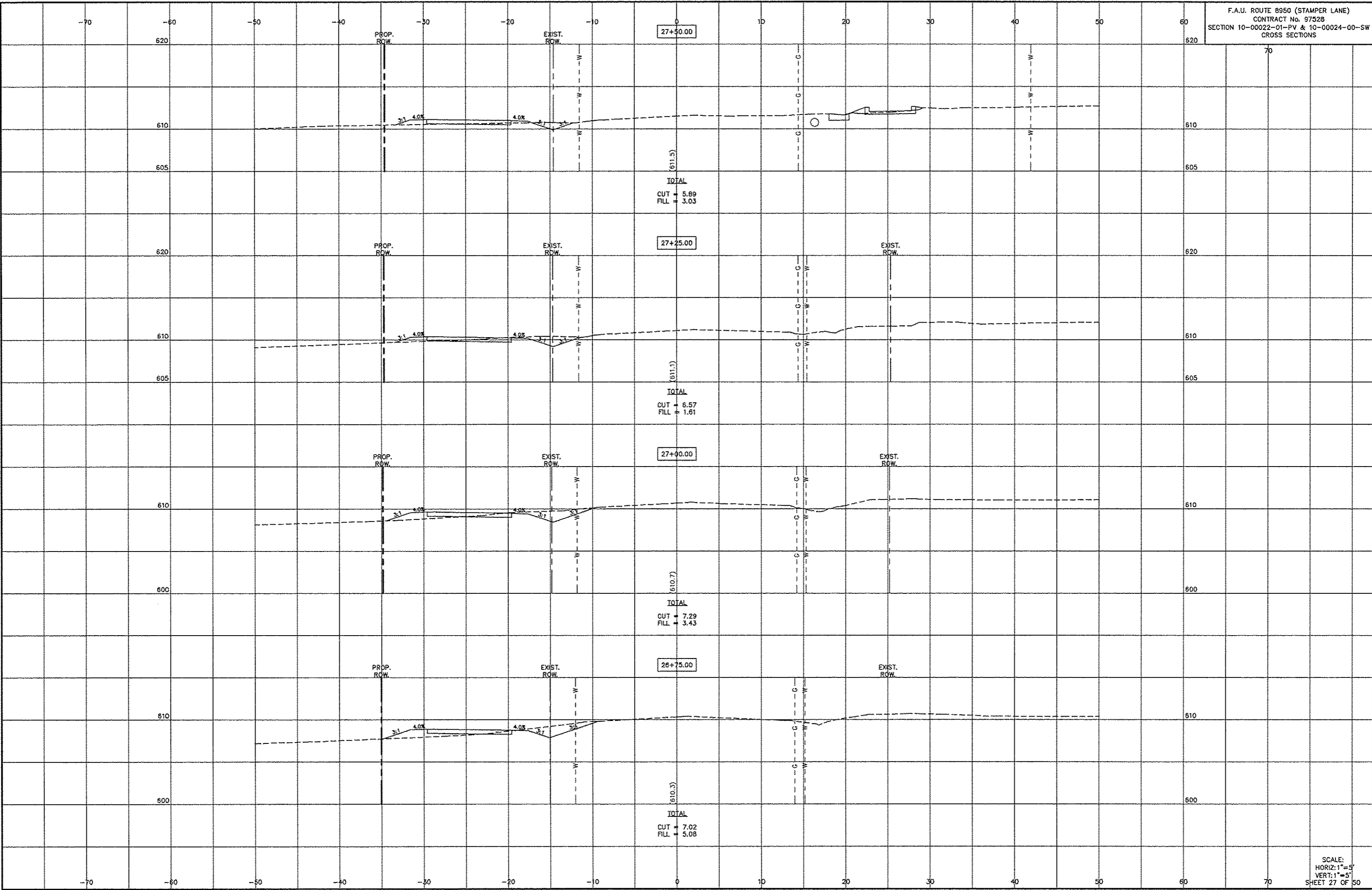

SCALE:
 HORIZ: 1"=5'
 VERT: 1"=5'

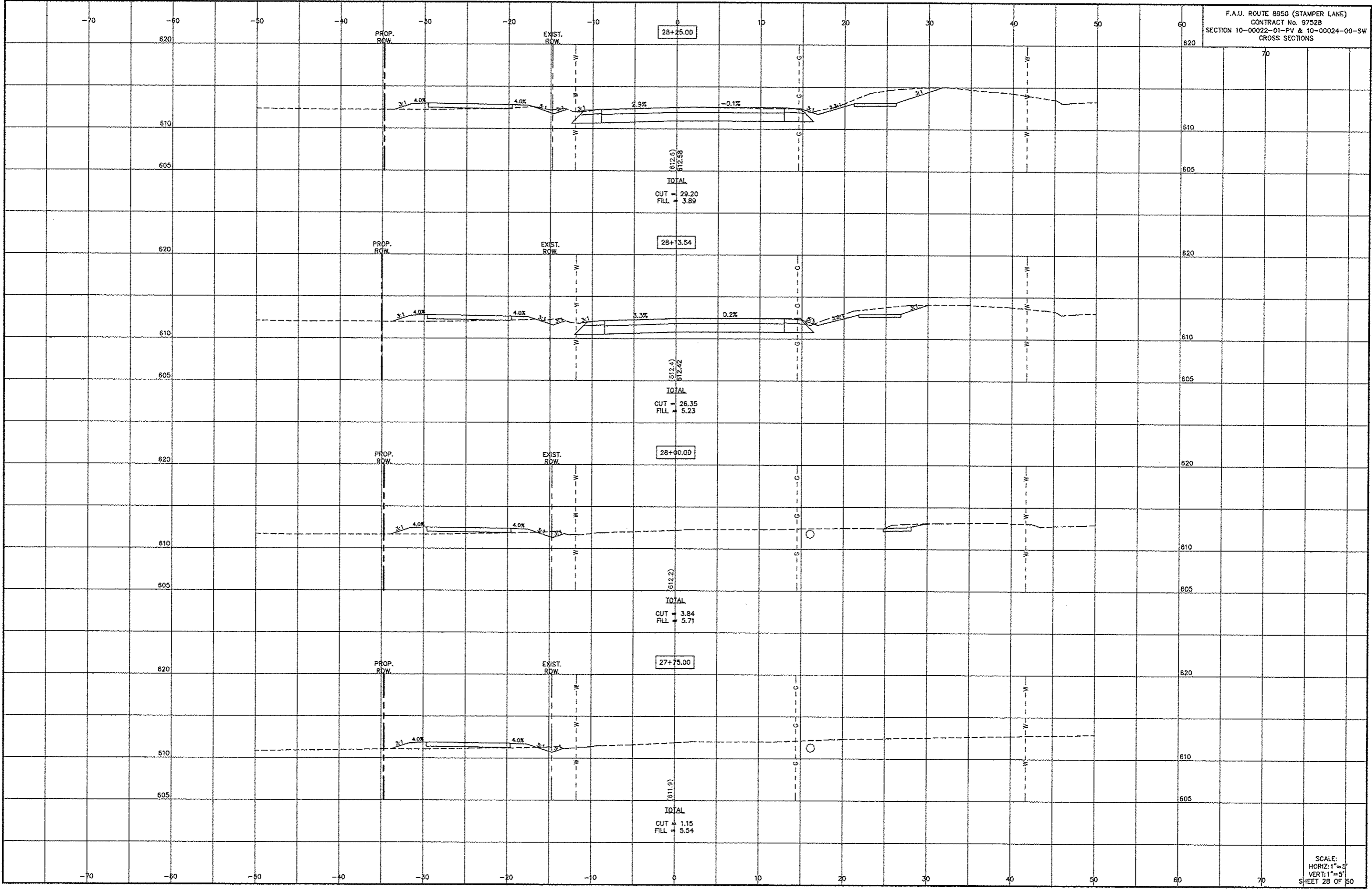

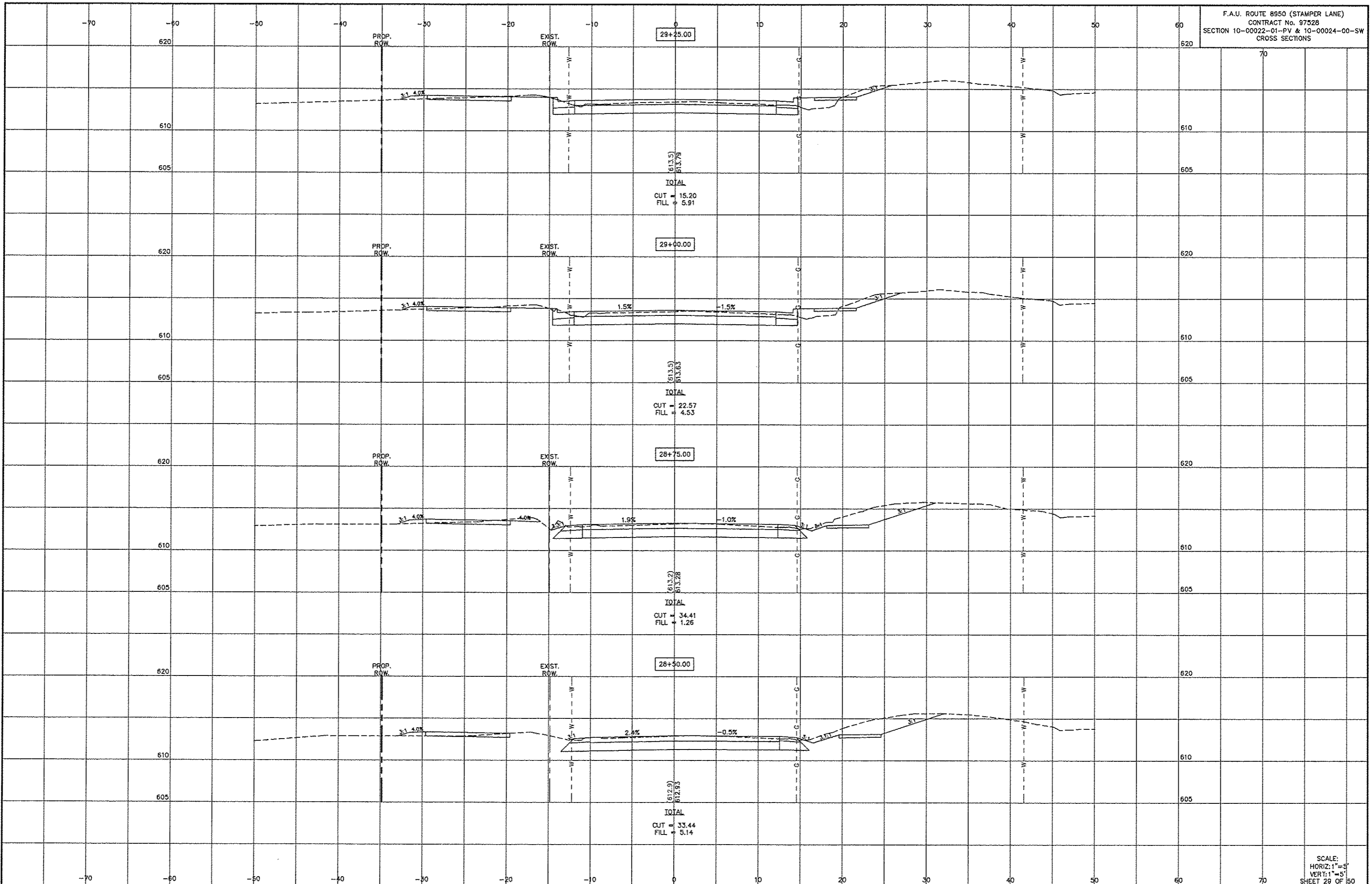

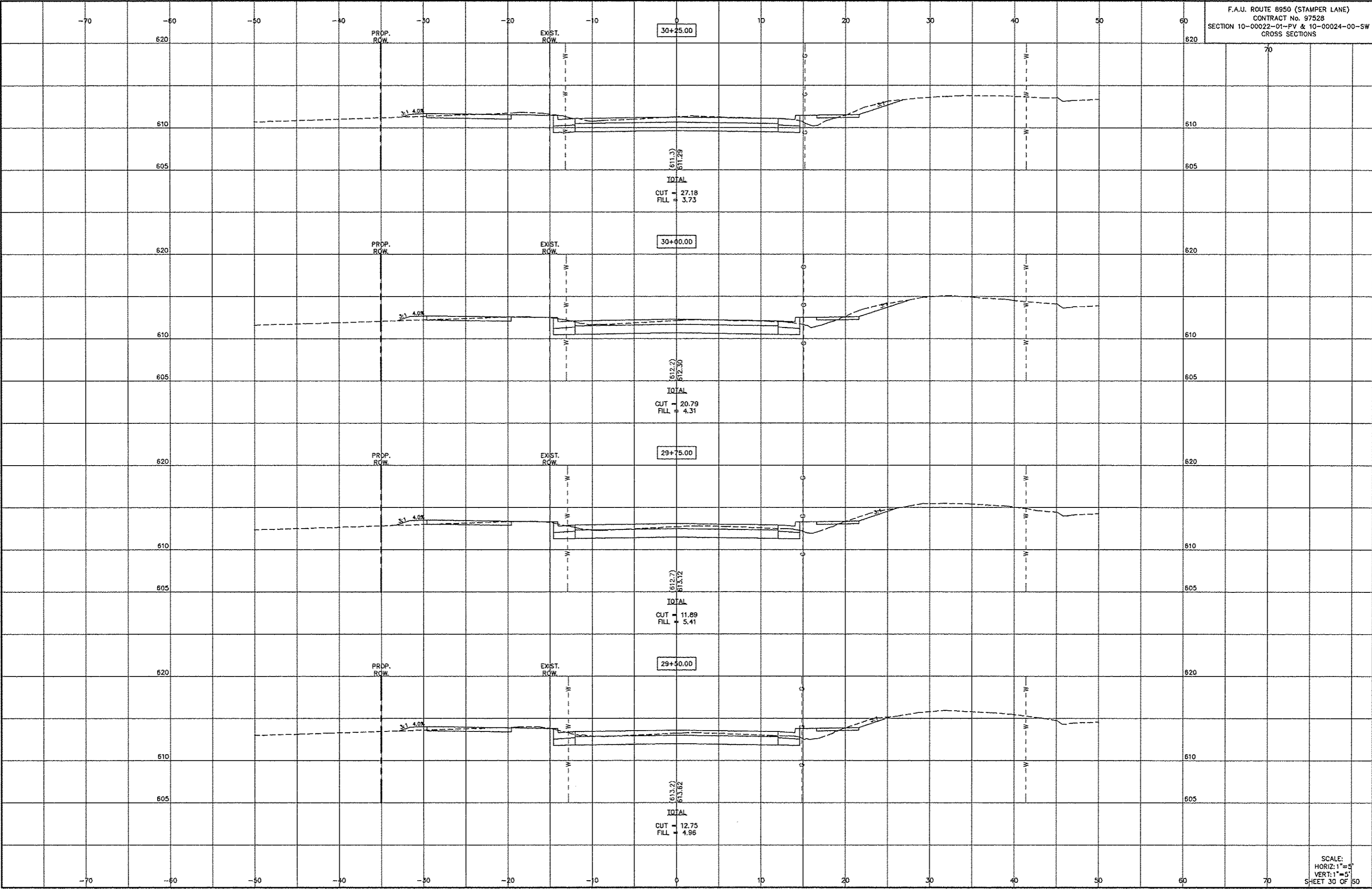

SCALE:
 HORIZ: 1"=5'
 VERT: 1"=5'

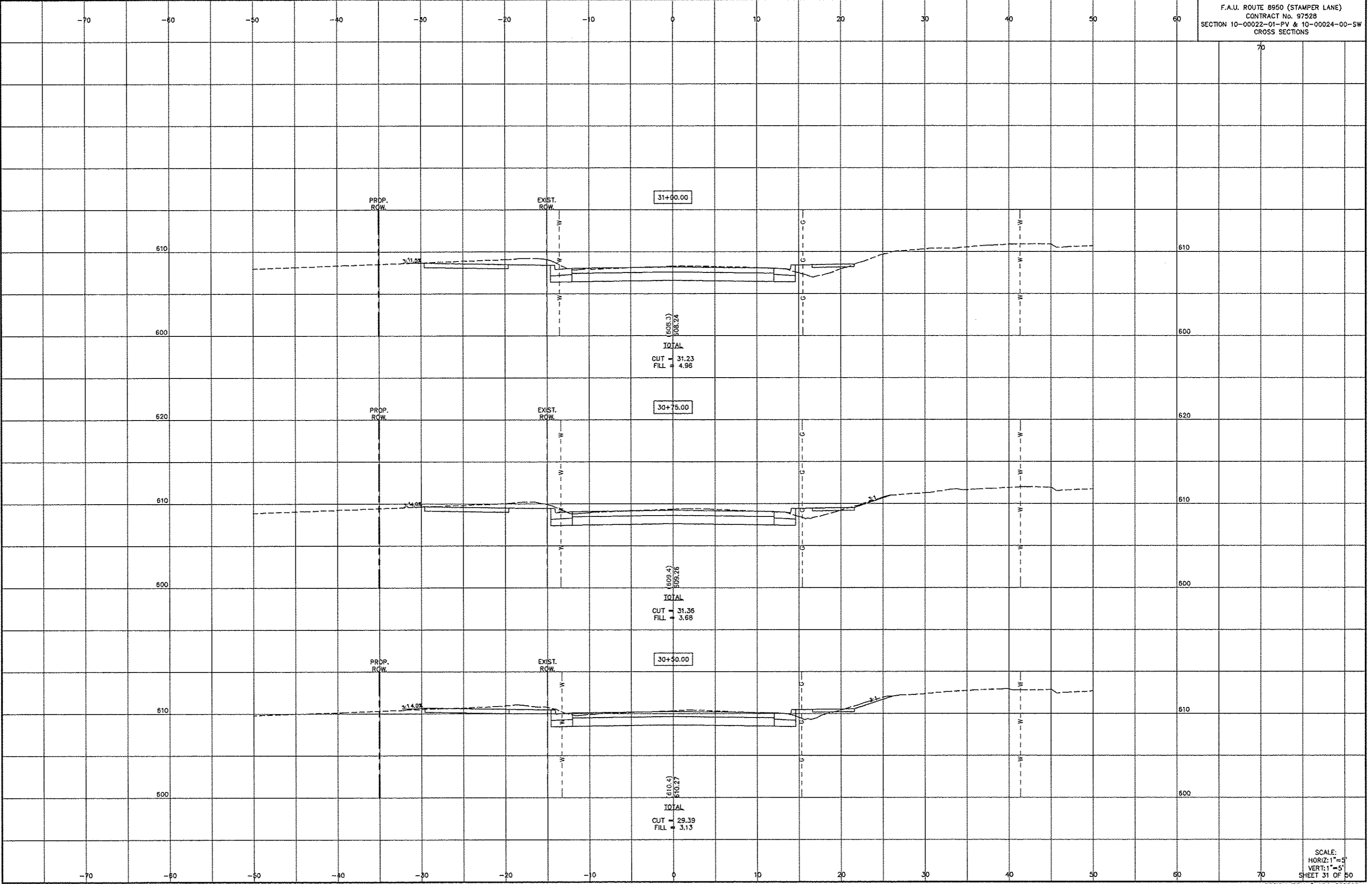

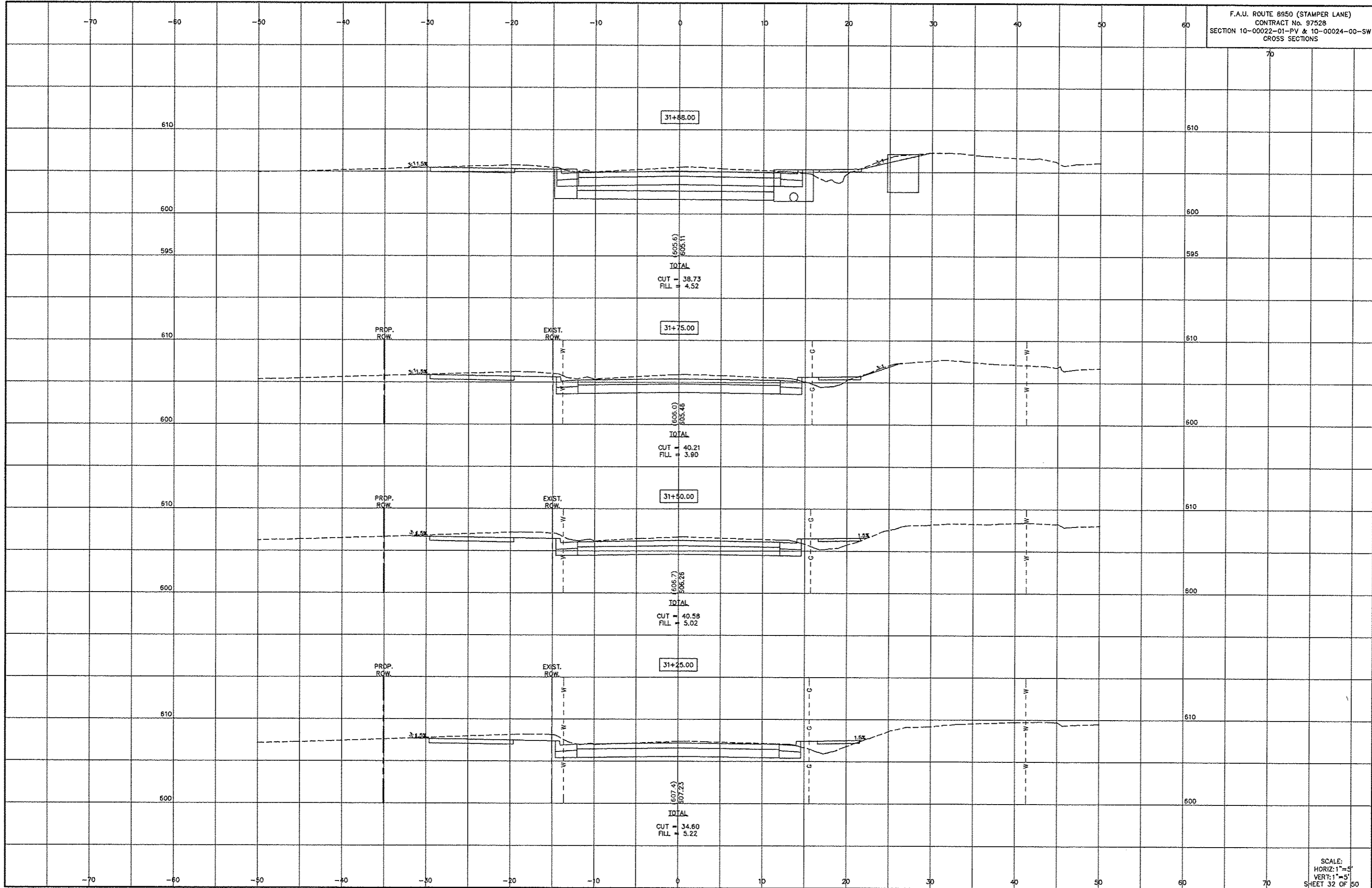

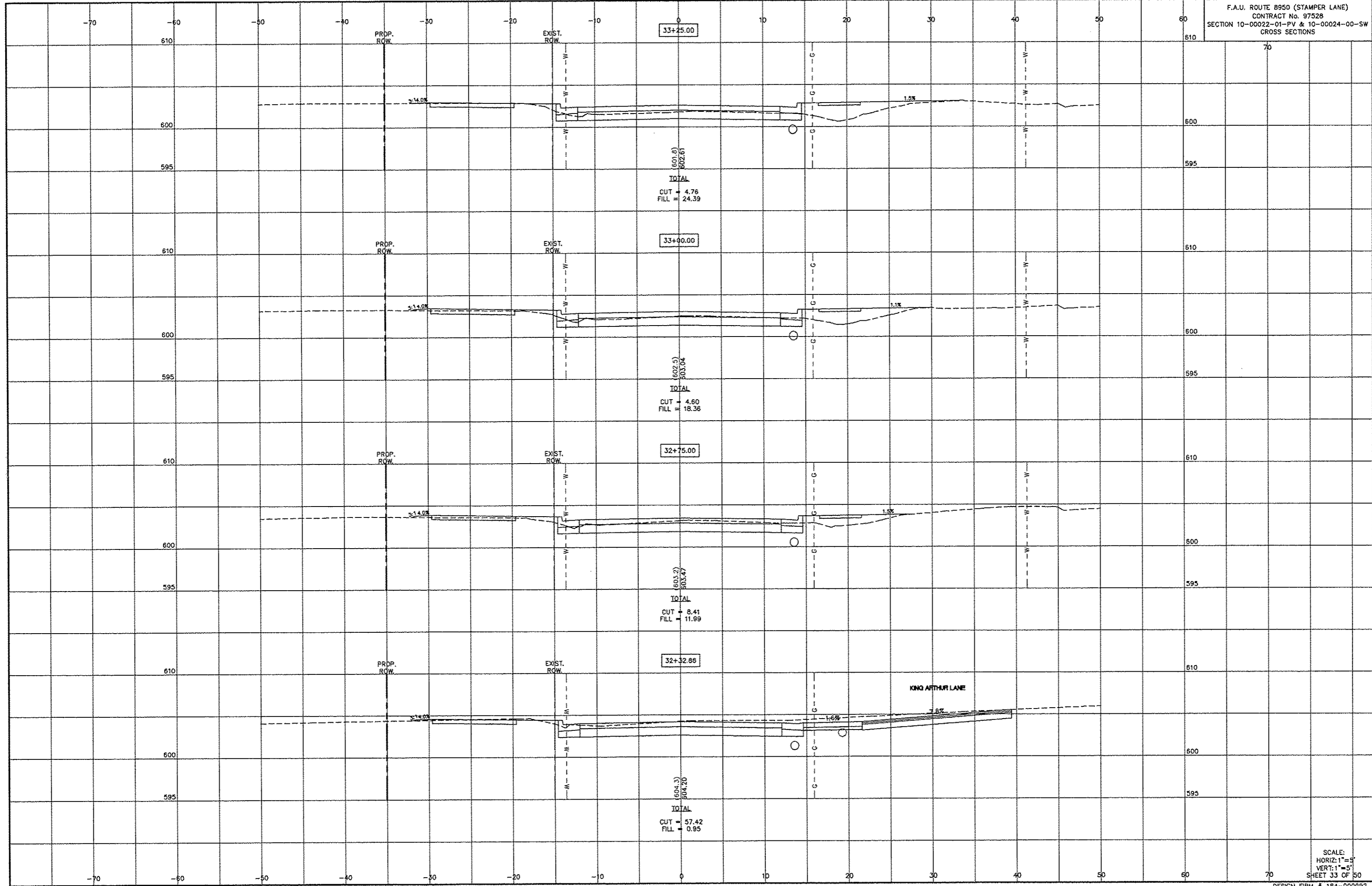

SCALE:
 HORIZ: 1"=5'
 VERT: 1"=5'
 SHEET 33 OF 50

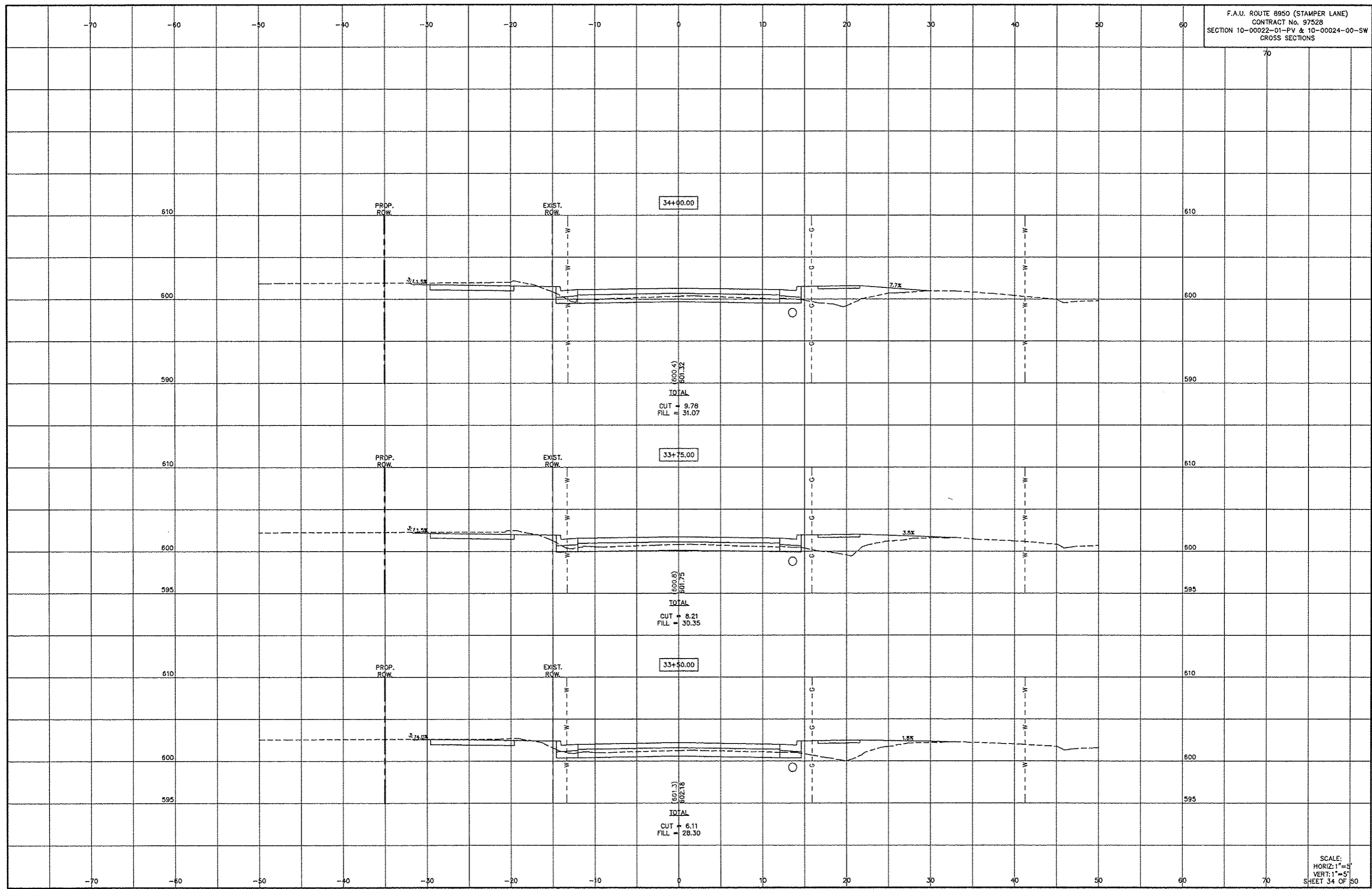

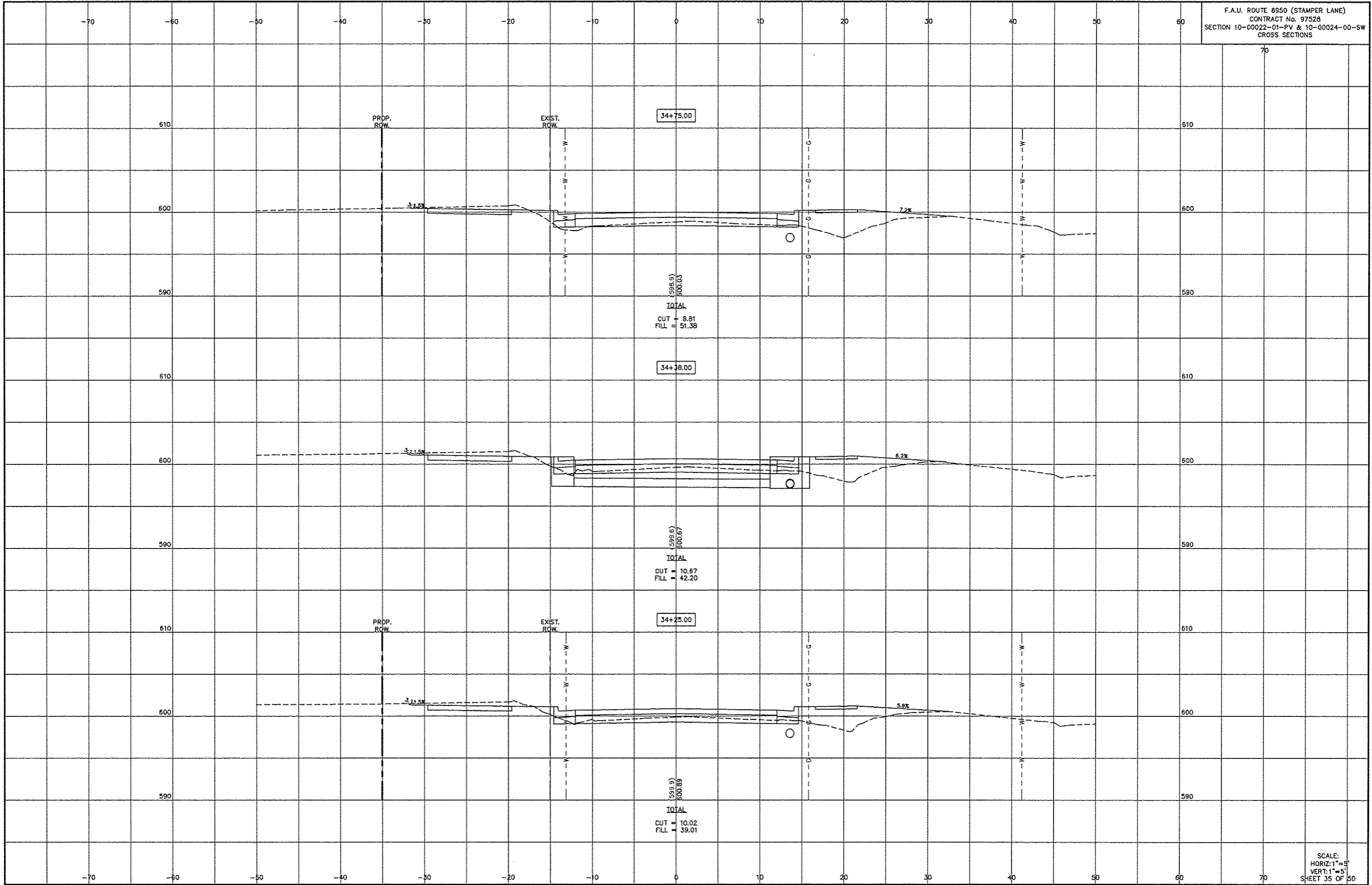

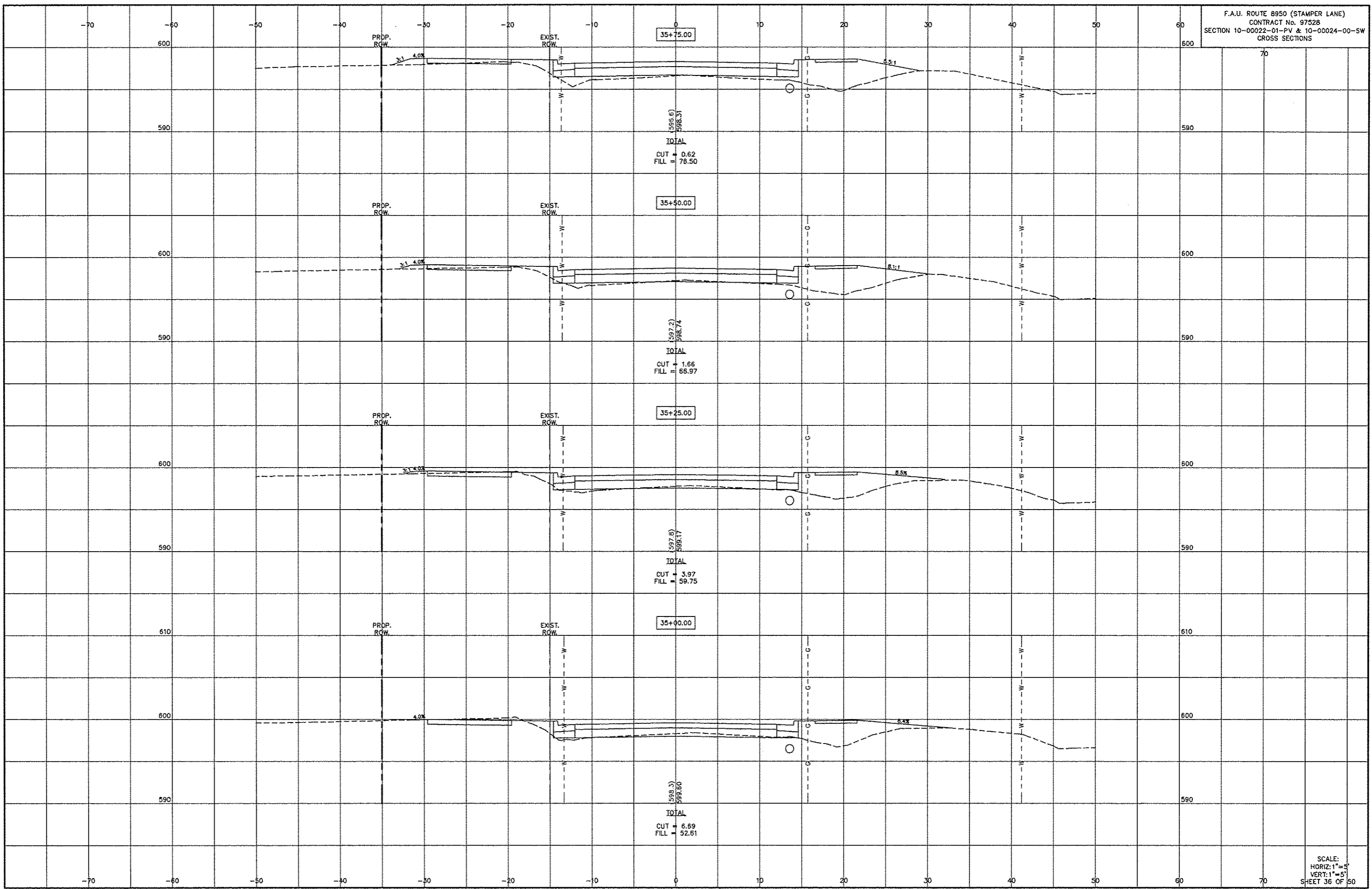

SCALE:
 HORIZ: 1"=5'
 VERT: 1"=5'

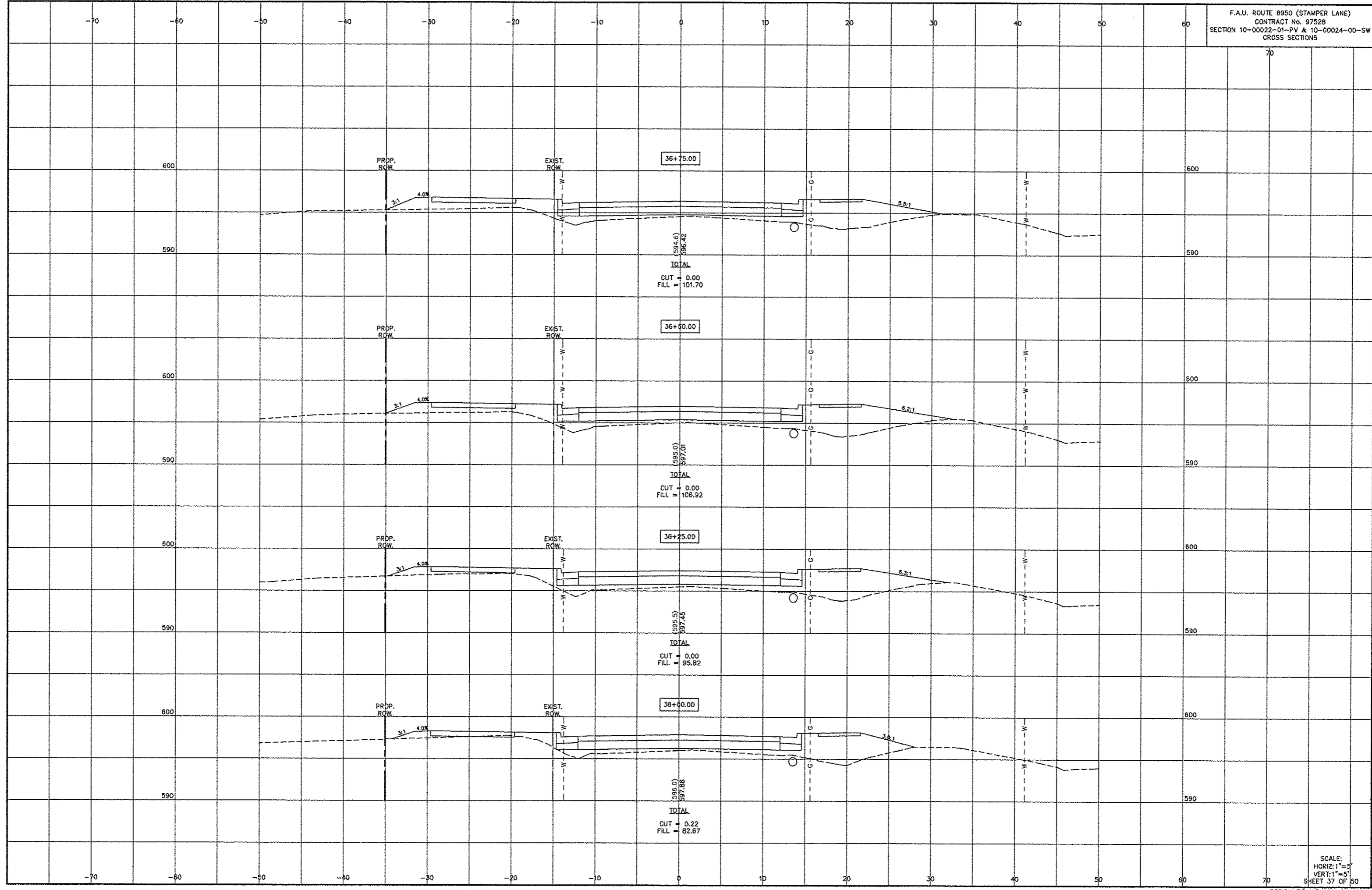

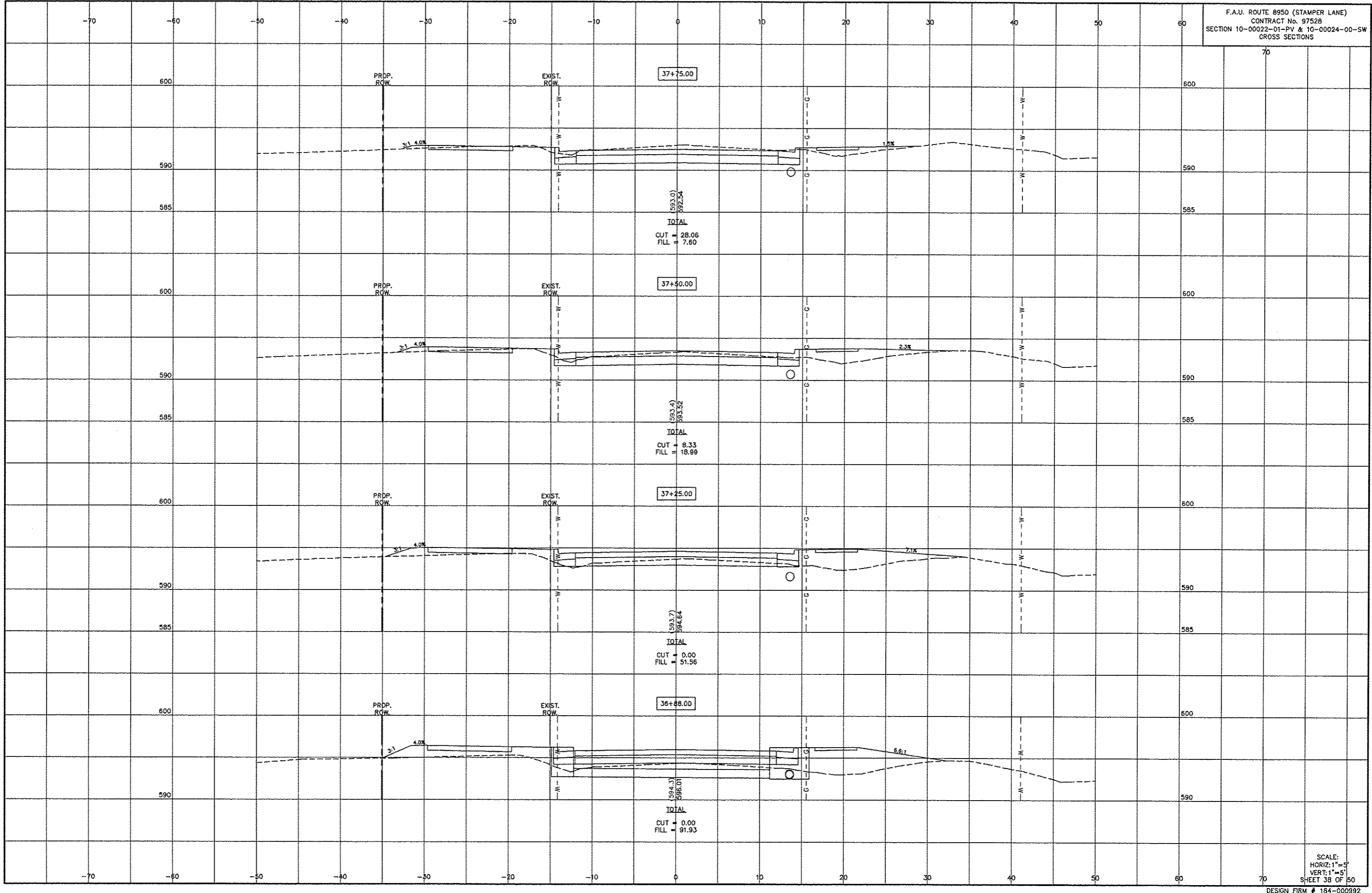

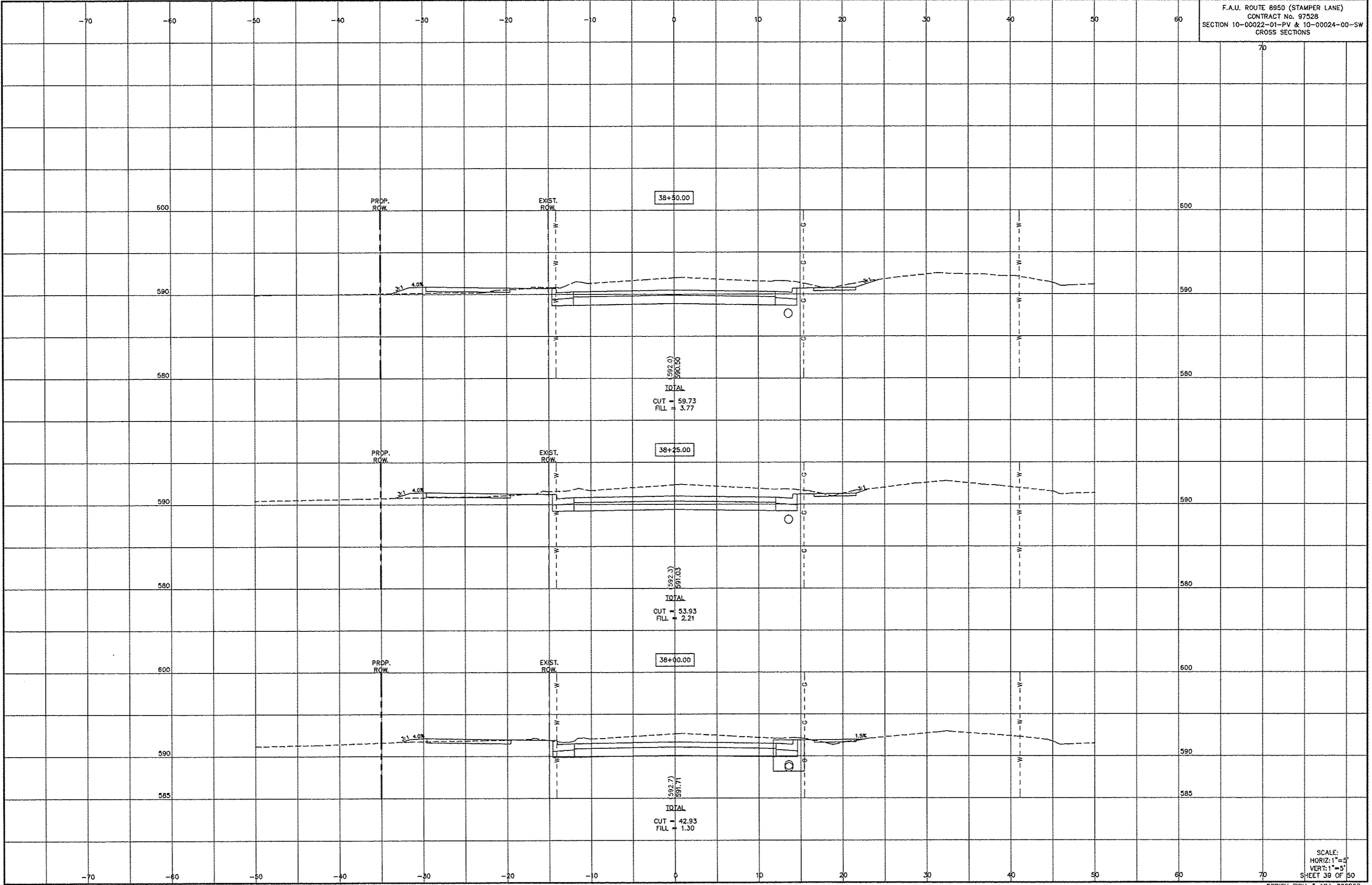

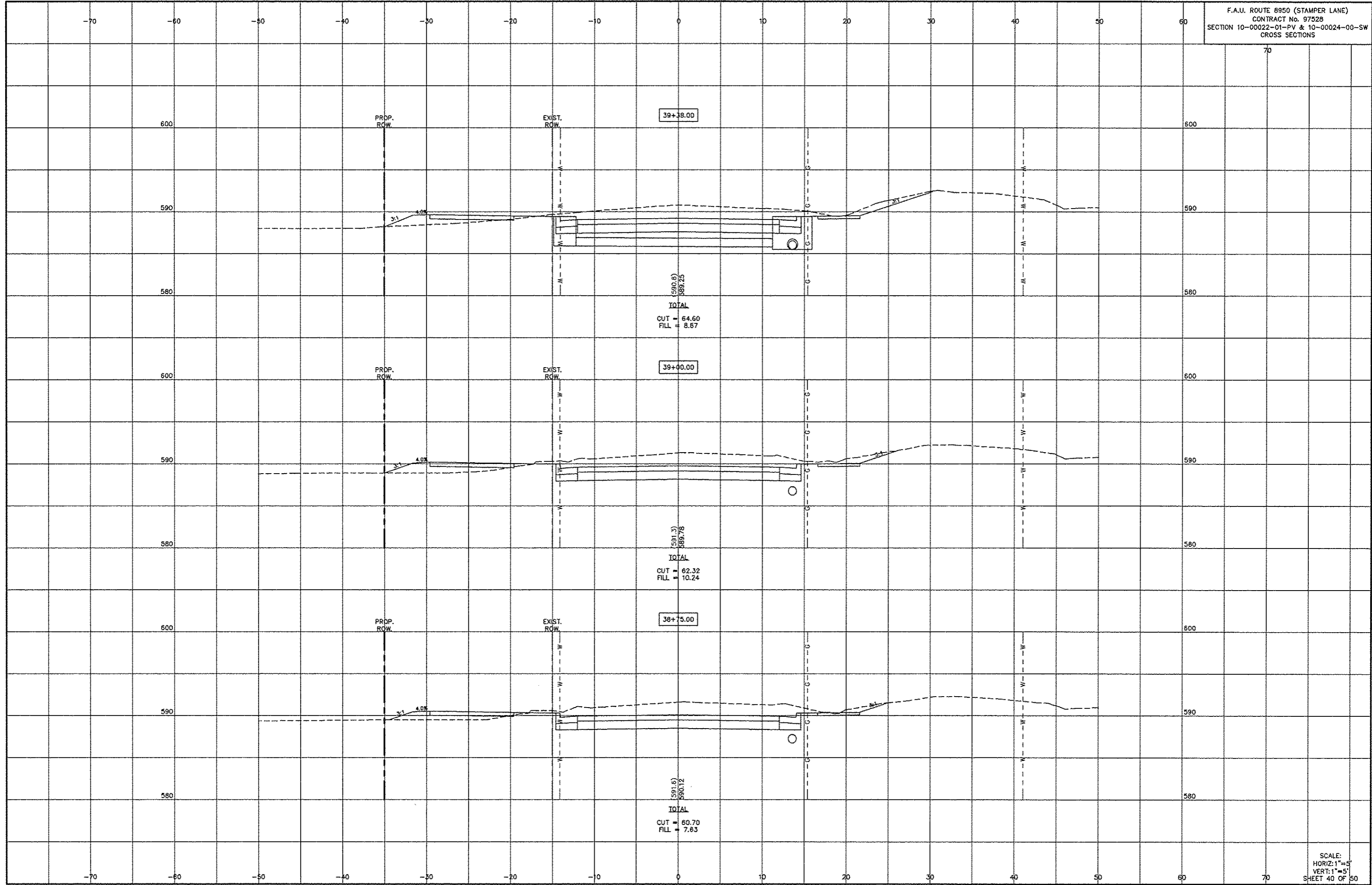

SCALE:
 HORIZ: 1"=5'
 VERT: 1"=5'
 SHEET 40 OF 50

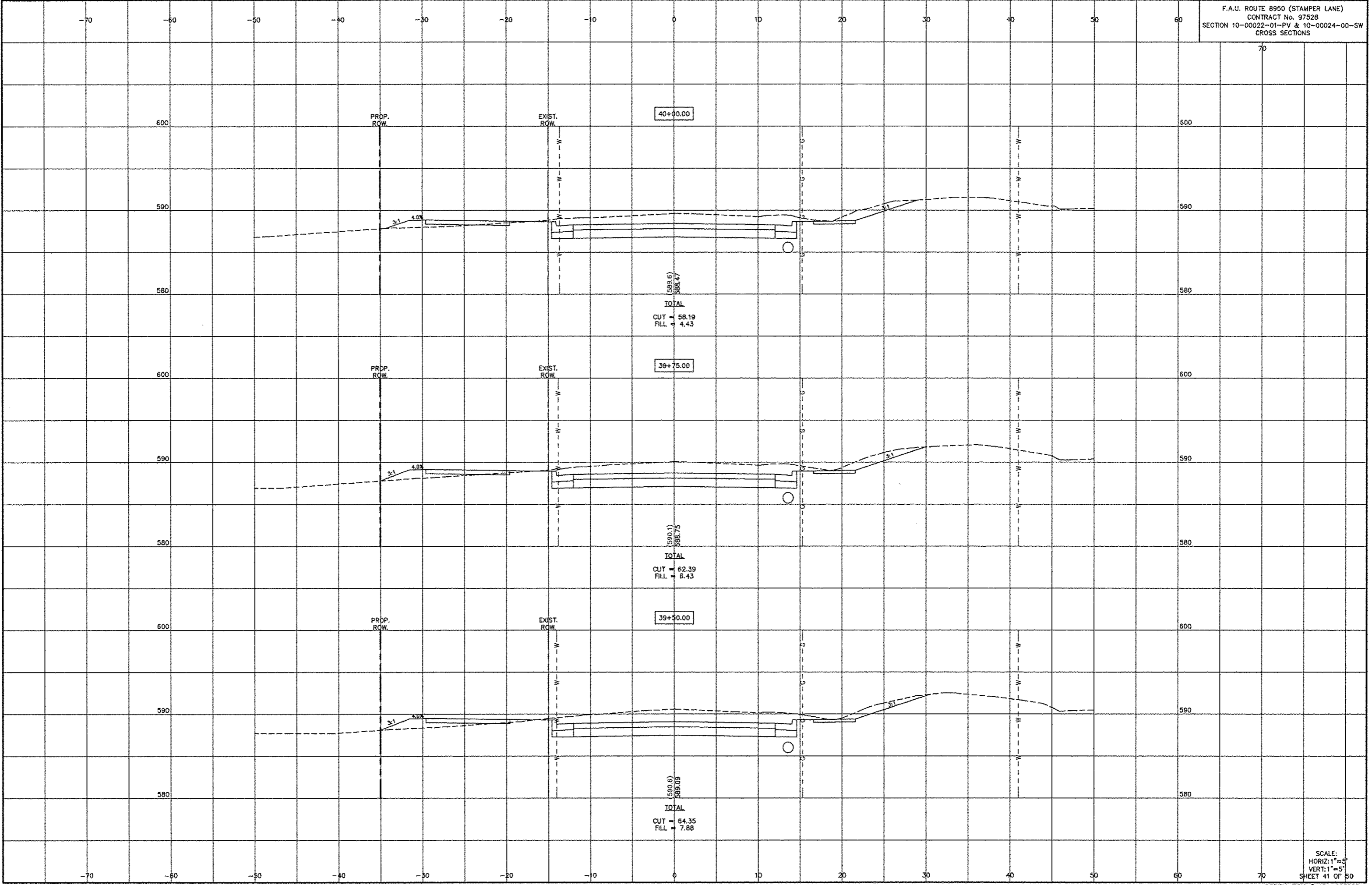

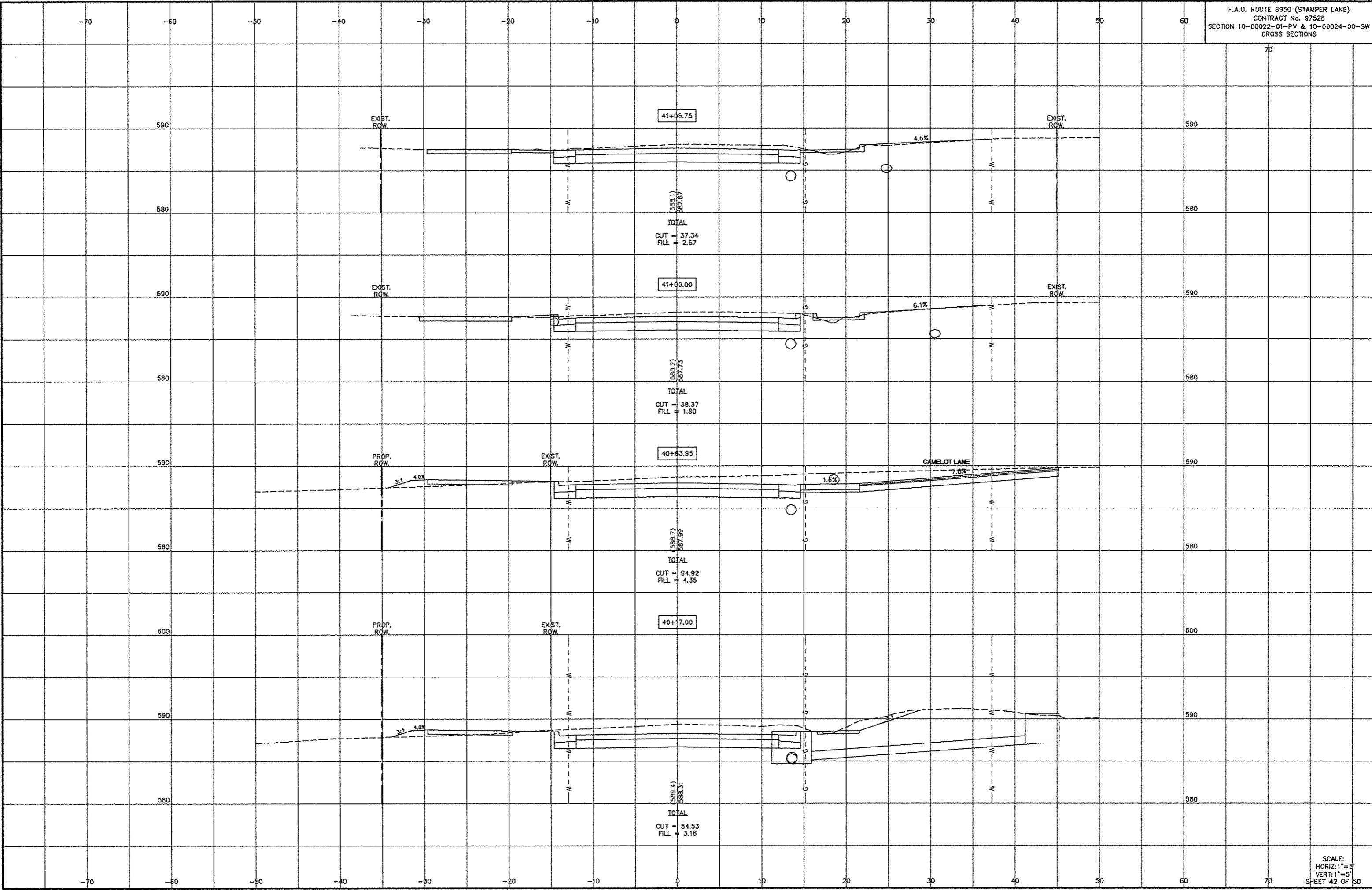

SCALE:
 HORIZ: 1"=5'
 VERT: 1"=5'

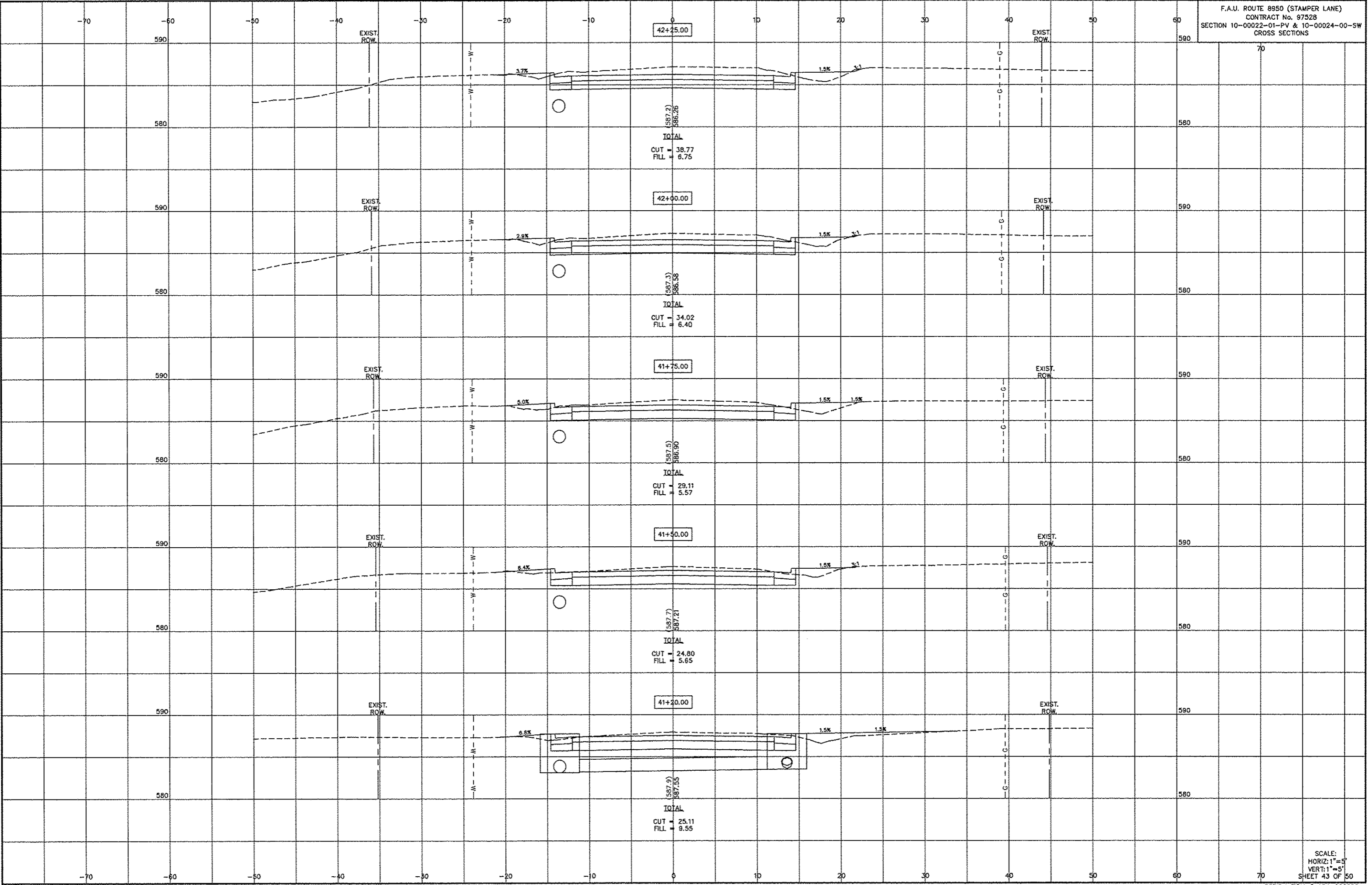

SCALE:
 HORIZ: 1"=5'
 VERT: 1"=5'

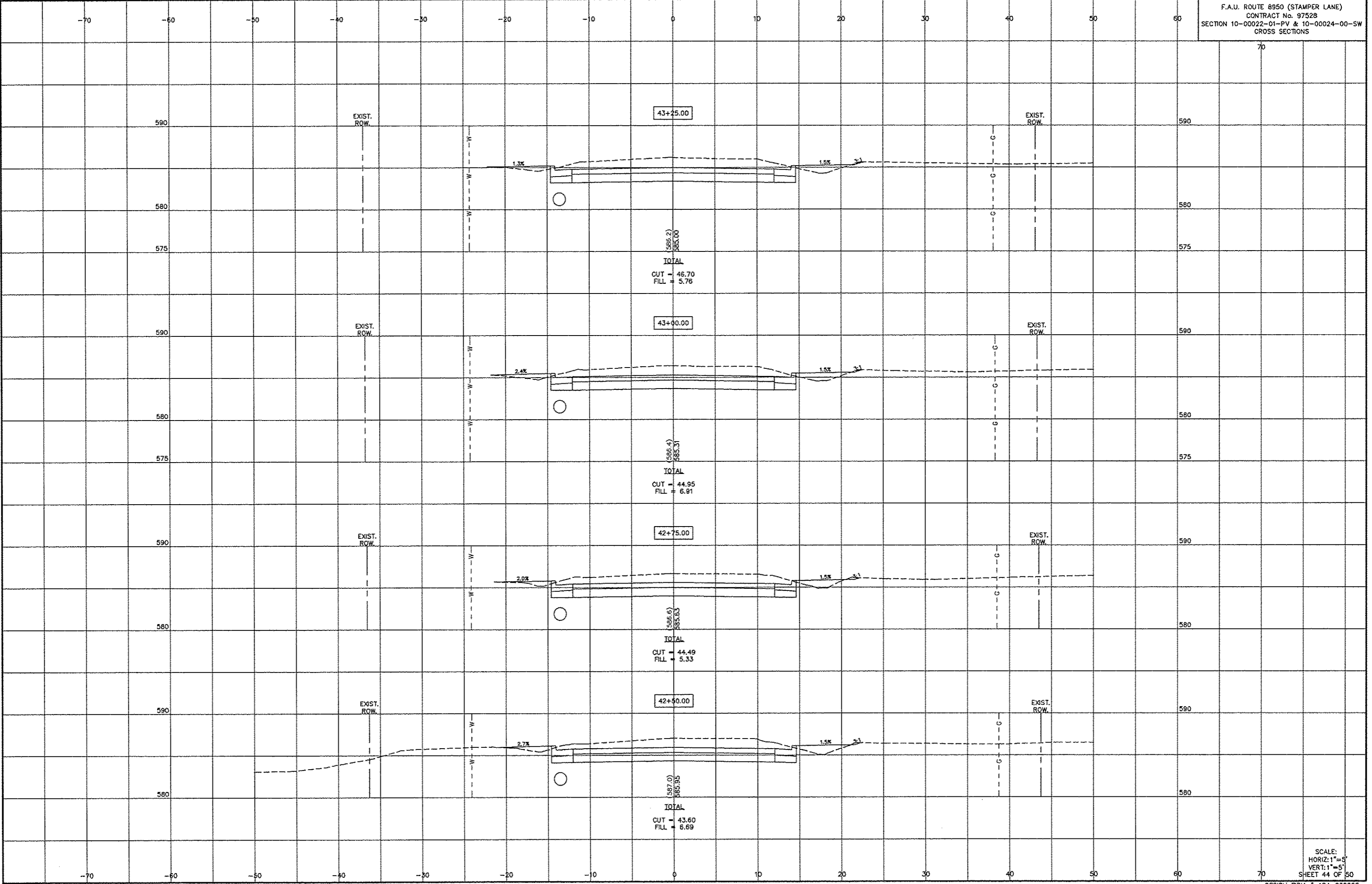

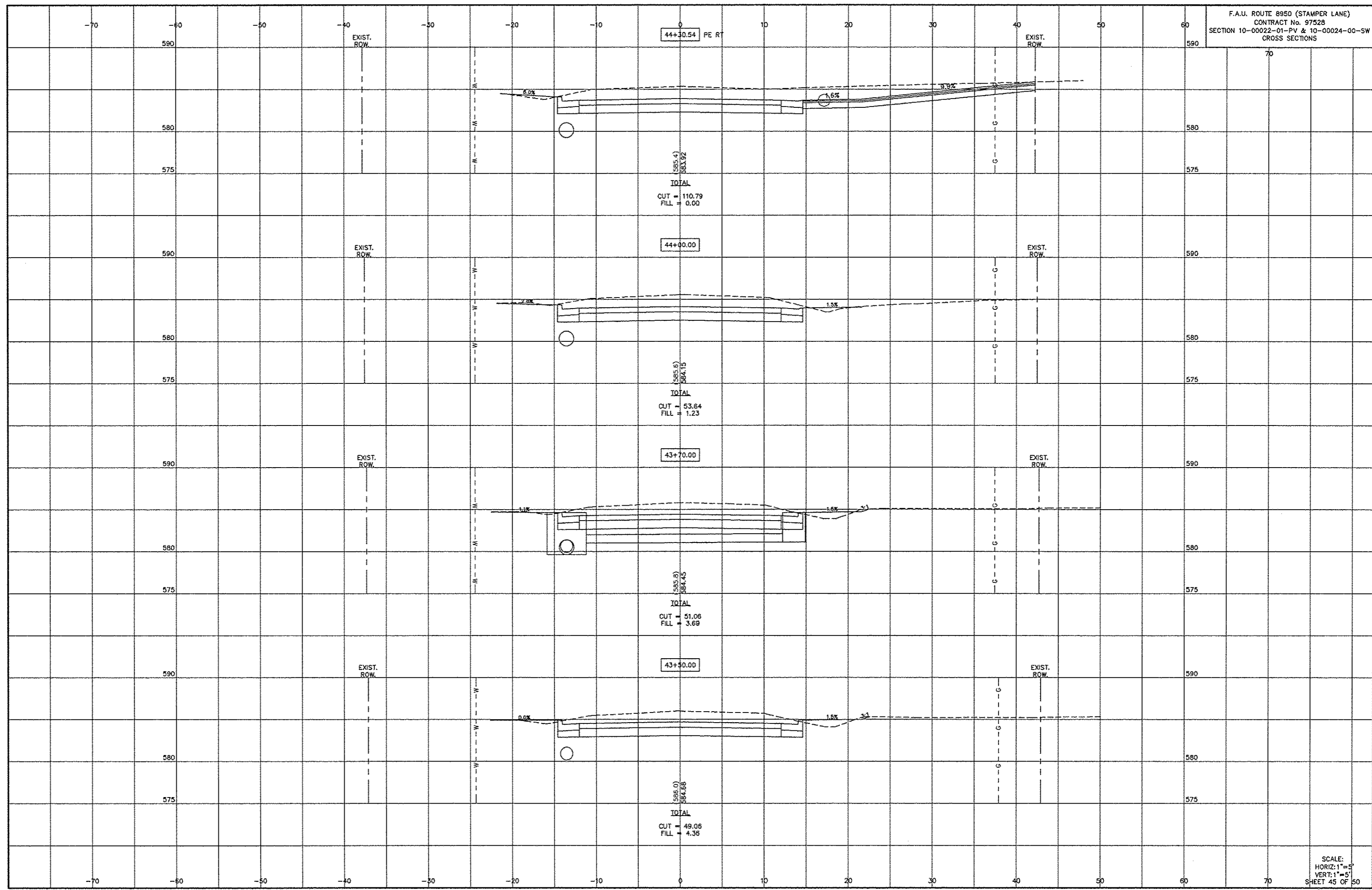

44+30.54 PE RT

EXIST. ROW

585.4
583.92
TOTAL
CUT = 110.79
FILL = 0.00

44+00.00

EXIST. ROW

585.6
584.15
TOTAL
CUT = 53.64
FILL = 1.23

43+70.00

EXIST. ROW

585.8
584.45
TOTAL
CUT = 51.06
FILL = 3.69

43+50.00

EXIST. ROW

586.0
584.88
TOTAL
CUT = 49.06
FILL = 4.36

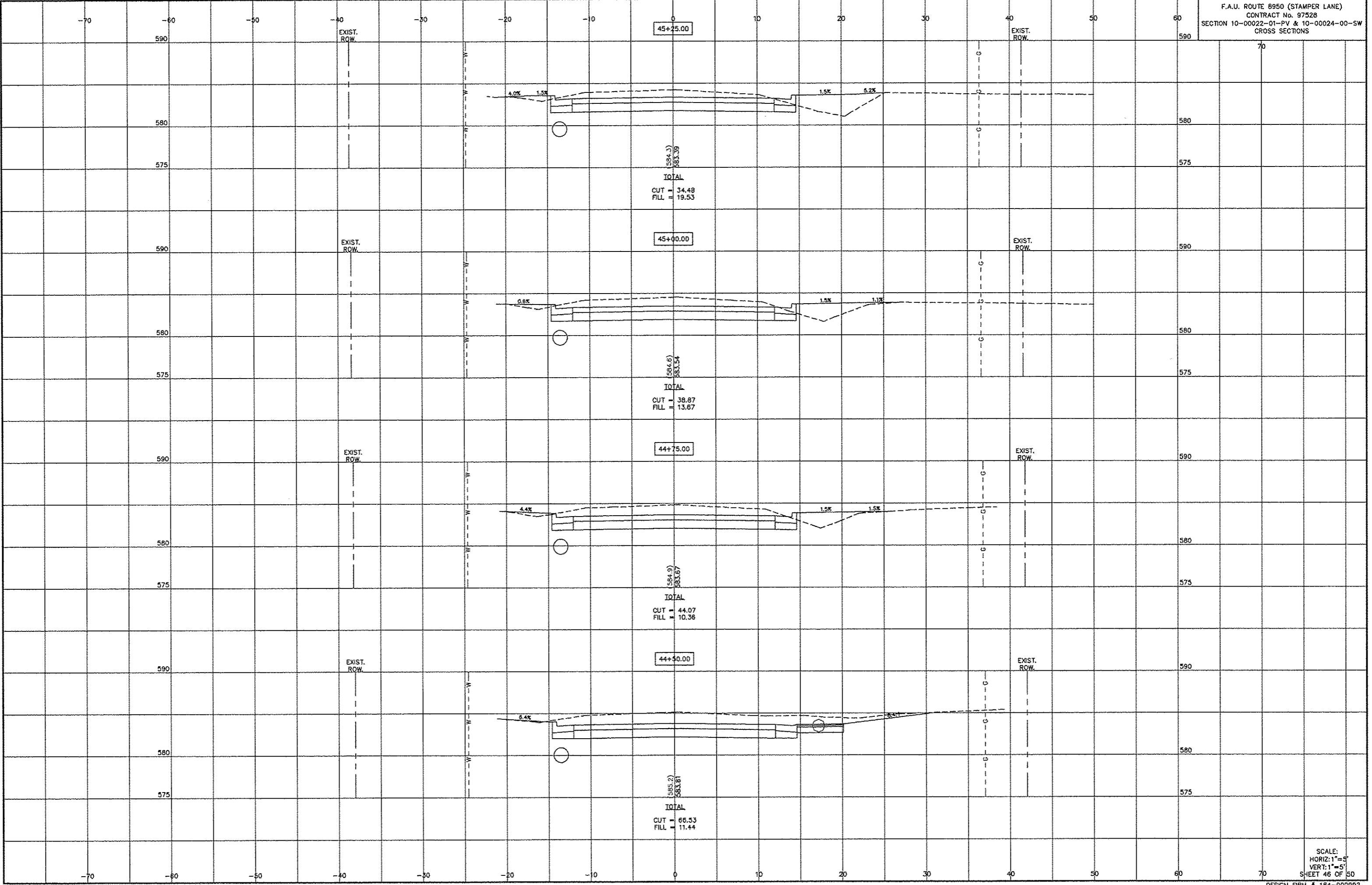

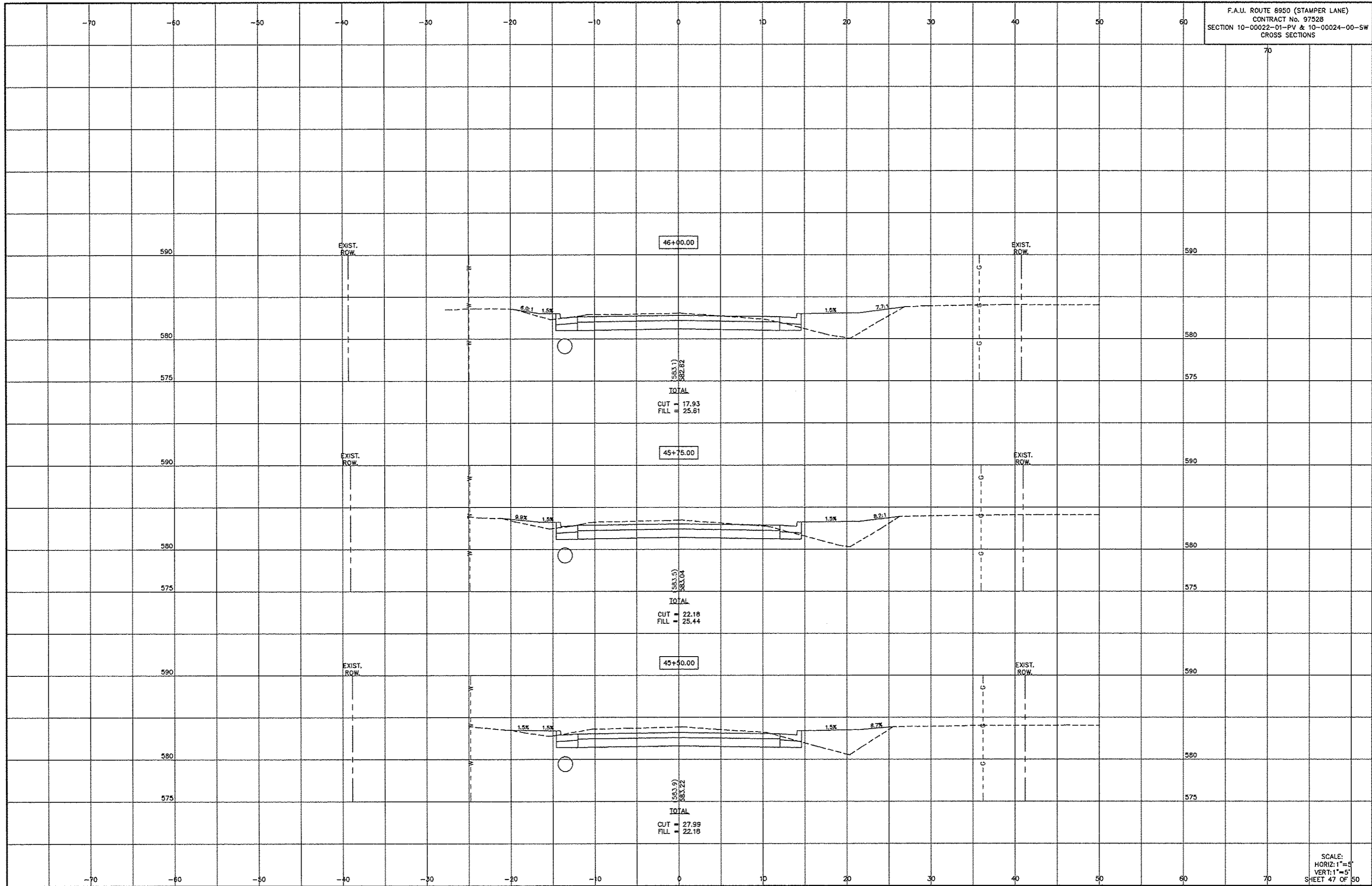

SCALE:
 HORIZ: 1"=5'
 VERT: 1"=5'

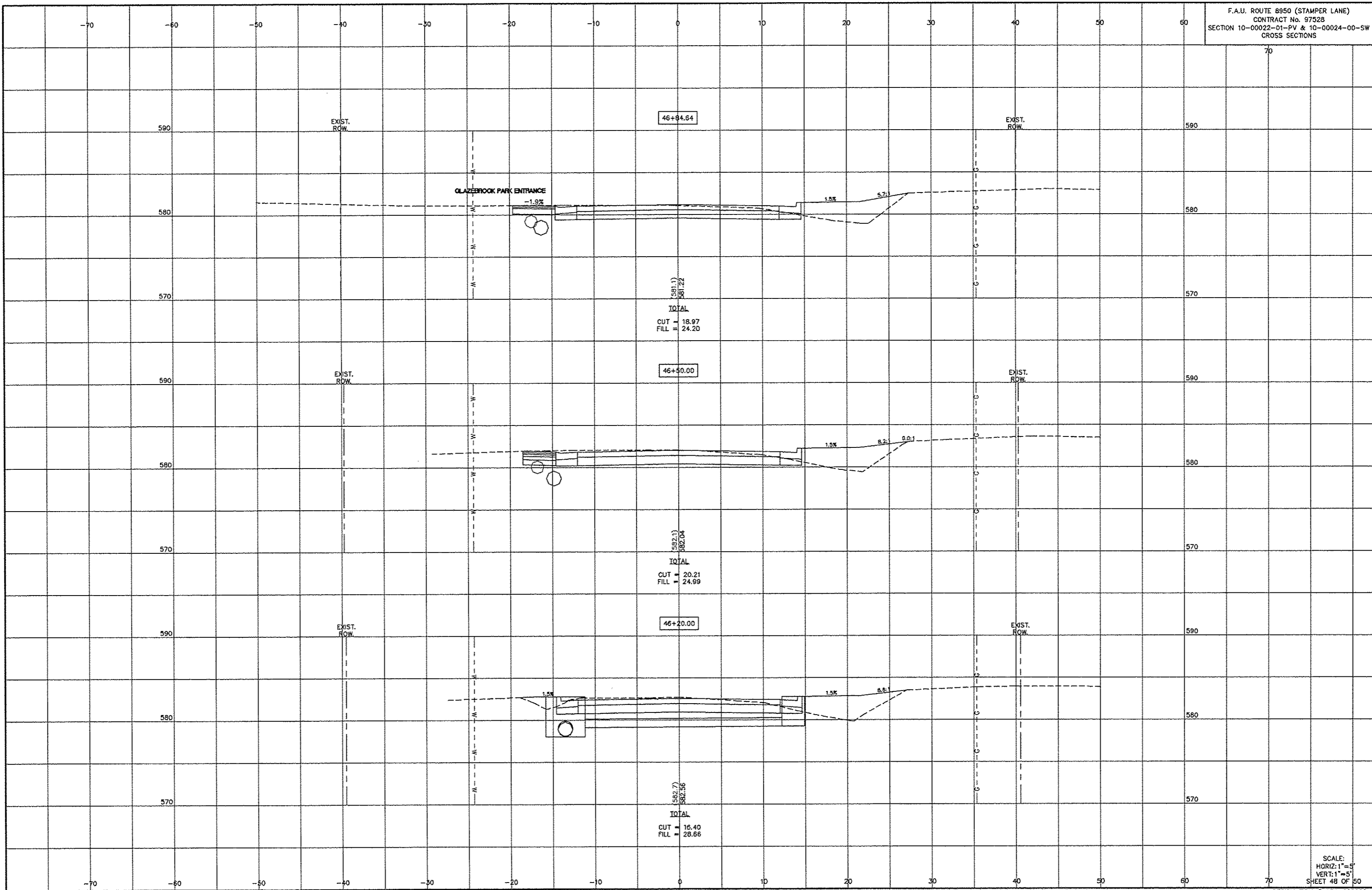

SCALE:
 HORIZ: 1"=5'
 VERT: 1"=5'
 SHEET 48 OF 50

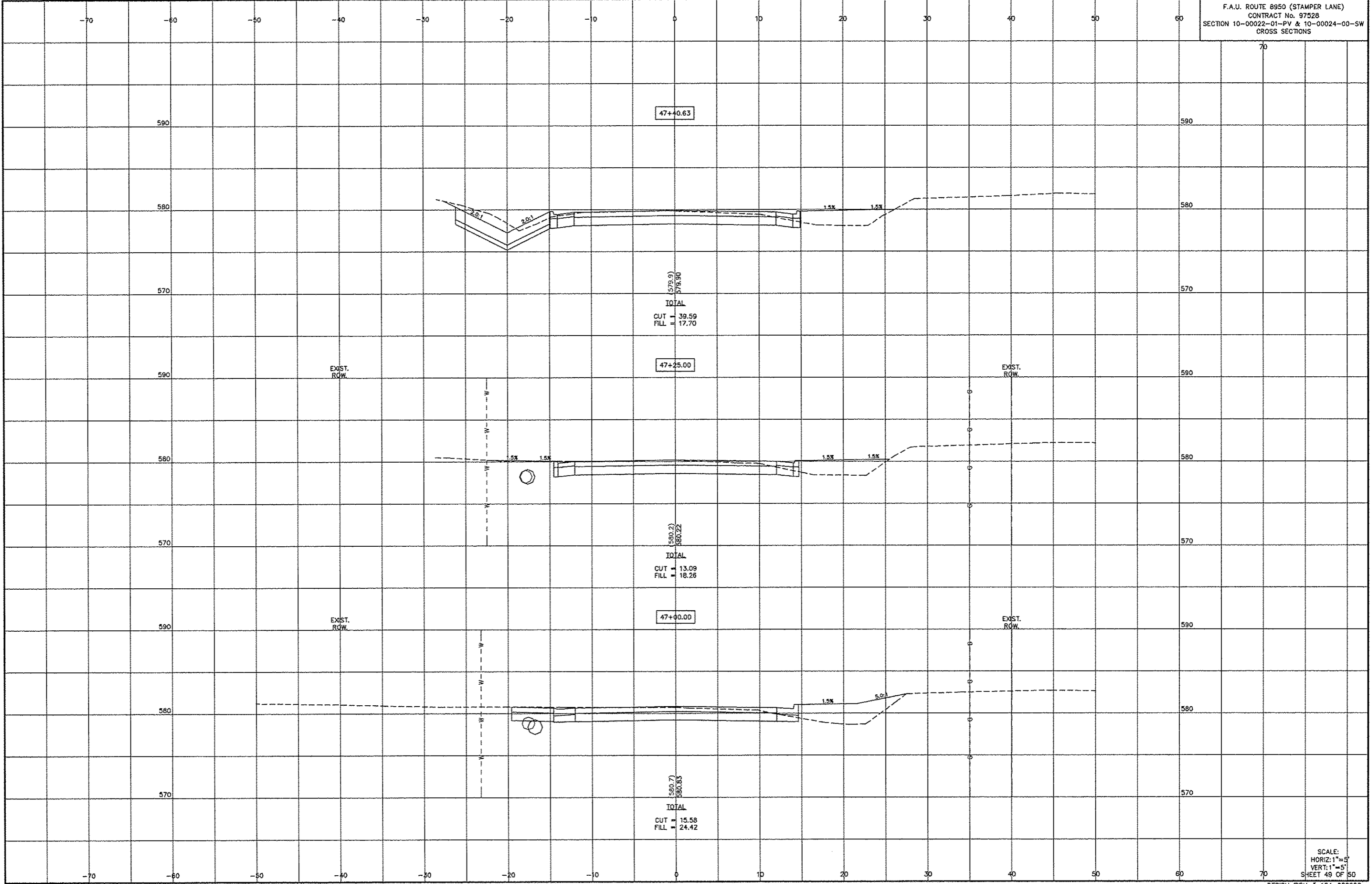

47+40.63

579.9
 579.90
 TOTAL
 CUT = 39.59
 FILL = 17.70

47+25.00

580.2
 580.22
 TOTAL
 CUT = 13.09
 FILL = 18.26

47+00.00

580.7
 580.83
 TOTAL
 CUT = 15.58
 FILL = 24.42

