

**ELEVATION OF BEAM**  
(Showing reinforcement & dimensions)

**SECTION A-A**

**SECTION B-B**

\* 3 spaces at 3" = 9".  
\*\* 4-3/4"  $\phi$  threaded dowel rods at 3" cts., Each Face

Note A:  
Hex nuts (top and bottom) with lock washers (top). Only tighten sufficiently to compress lock washers.

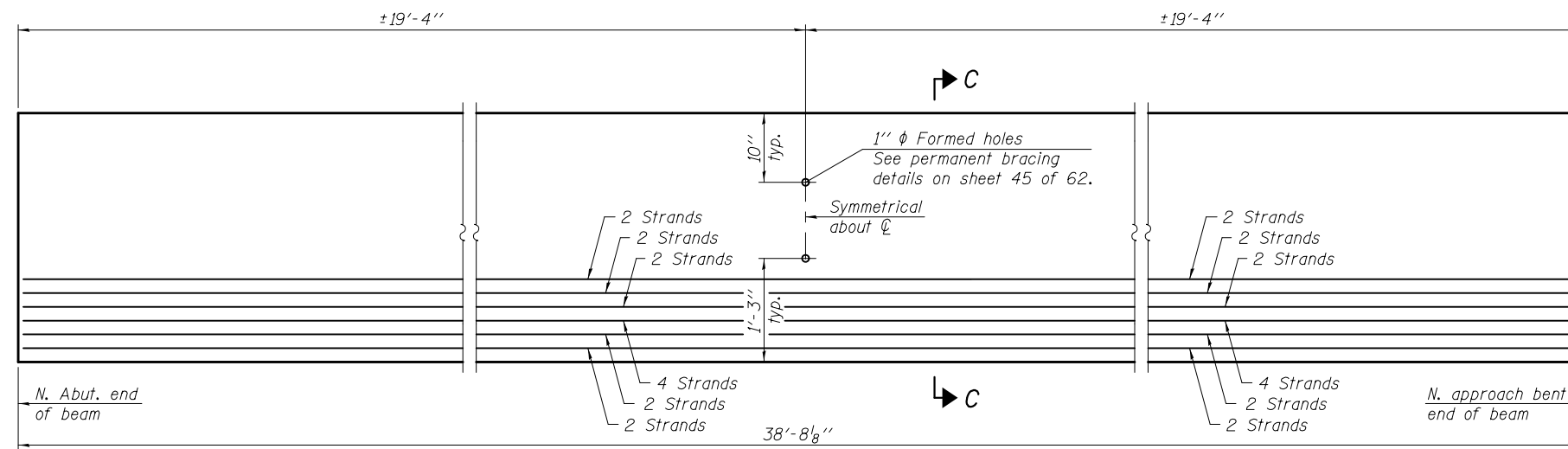

**ELEVATION OF BEAM**  
(Showing prestressing steel)

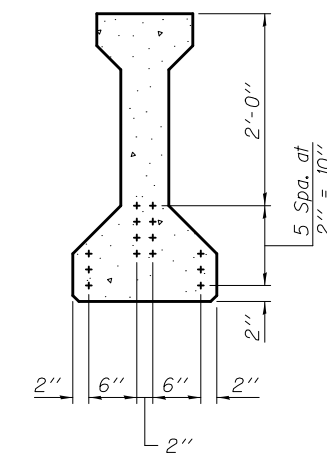

**SECTION C-C**

**\*\*\*BAR LIST  
ONE BEAM ONLY**

Bar	No.	Size	Length	Shape
G <sub>1</sub>	38	#4	7'-7"	⊔
G <sub>2</sub>	8	#4	5'-8"	⊔
G <sub>3</sub>	3	#5	38'-6"	—
G <sub>4</sub>	38	#3	4'-1"	⊔

\*\*\*For information only

Notes:  
See sheet 45 of 62 for additional details and Bill of Material.  
Required release strength,  $f'_{ci}$ , shall be 5,000 psi.