

**SIDEWALK SPECIAL, DETAIL FOR INLET ADJUSTMENT**

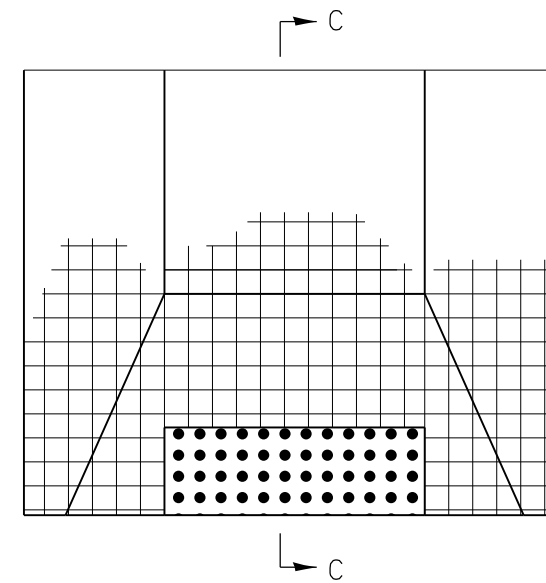

**SIDEWALK SPECIAL, FOR CURB RAMP**

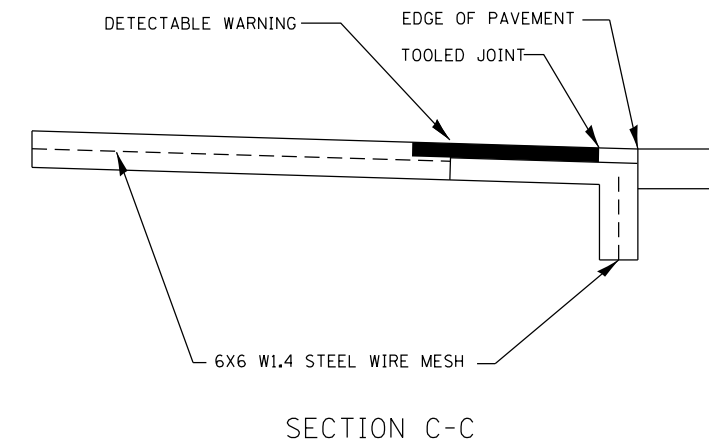

NOTE:  
CONTRACTOR SHALL OMIT WIRE MESH FROM DETECTABLE WARNING AREA

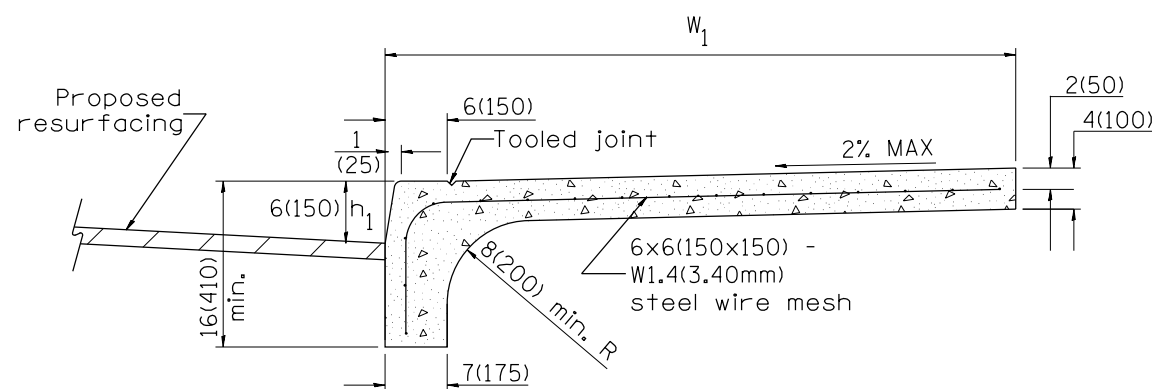

**COMBINATION CURB - SIDEWALK 4"(100mm)**

Measurement Formula:  $(W_1 + h_1) \times \text{length constructed} = \text{Payment area}$   
in square meters(square feet)

**GENERAL NOTES:**

- All provisions in Section 424 of the Standard Specifications shall apply, unless otherwise shown.

FILE NAME = 68982.dgn	USER NAME = aubreys	DESIGNED -	REVISED -	<b>STATE OF ILLINOIS DEPARTMENT OF TRANSPORTATION</b>	<b>PCC SIDEWALK 4 INCH SPL, DETAIL</b>		F.A.S. RTE. 2361	SECTION 10IRS-4;102RS-5	COUNTY MARSHALL	TOTAL SHEETS 51	SHEET NO. 41	
	PLOT SCALE = 48.0000' / in.	DRAWN -	REVISED -		SCALE:	SHEET 41 OF 51 SHEETS	<b>CONTRACT NO.</b>		ILLINOIS FED. AID PROJECT			
	PLOT DATE = 3/21/2013	CHECKED -	REVISED -									
		DATE -	REVISED -									