

\*USE STANDARD DETECTABLE WARNING W/ DIMENSIONS OF 5' X '2, UNLESS OTHERWISE NOTED.

SIDEWALK REMOVAL SPECIAL = 38.0 SQ FT

SIDEWALK REMOVAL = 188.0 SQ FT

SIDEWALK REMOVAL = 114 SQ FT

PROP. PCC SIDEWALK= 181.5 SQ. FT  
USE RURAL DETAIL A-A AND B-B  
DETECTABLE WARNINGS= 20 SQ FT.

PROP. PCC SIDEWALK 4", SPL = 188.0 SQ FT  
USE STANDARD 424021  
DETECTABLE WARNINGS = 50.3 SQ FT

PROP. PCC SIDEWALK = 47.5 SQ FT

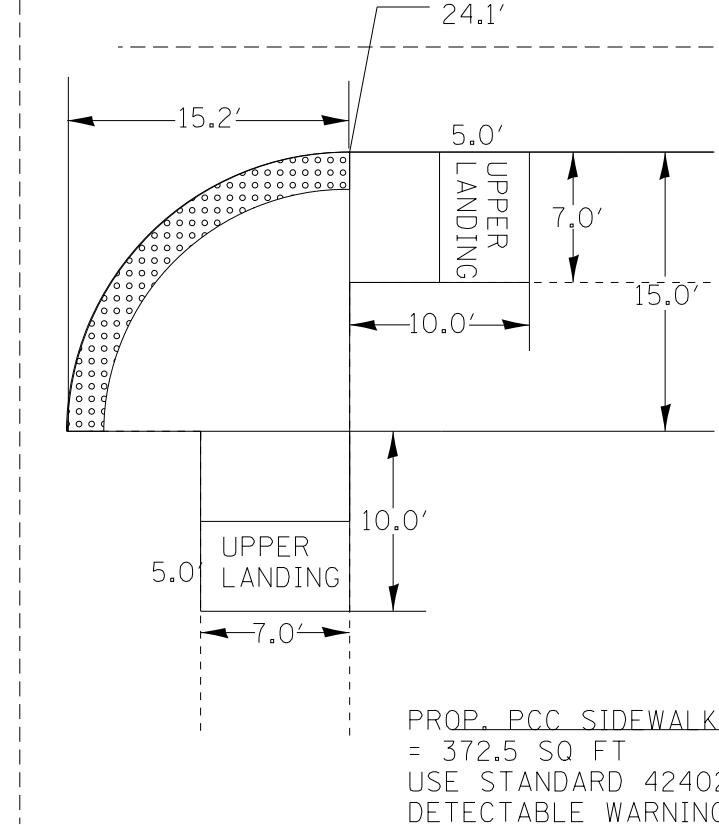
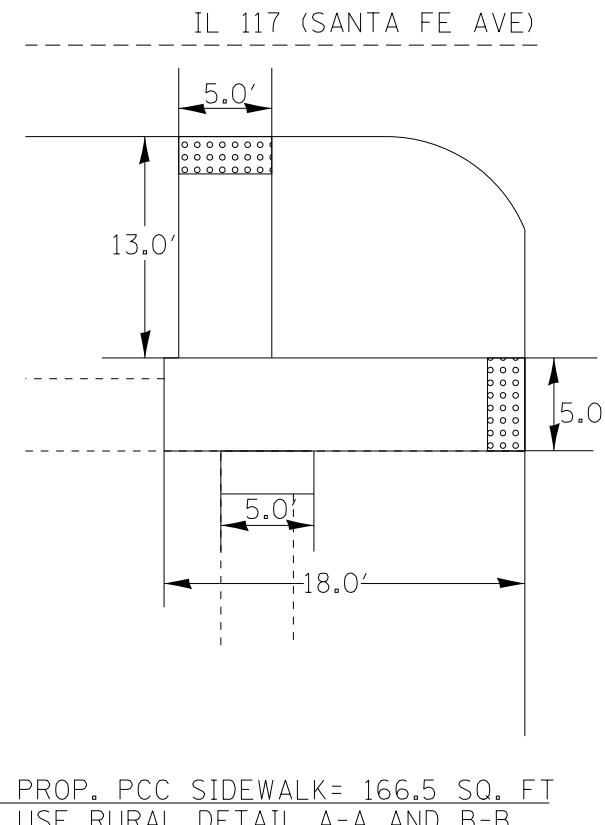
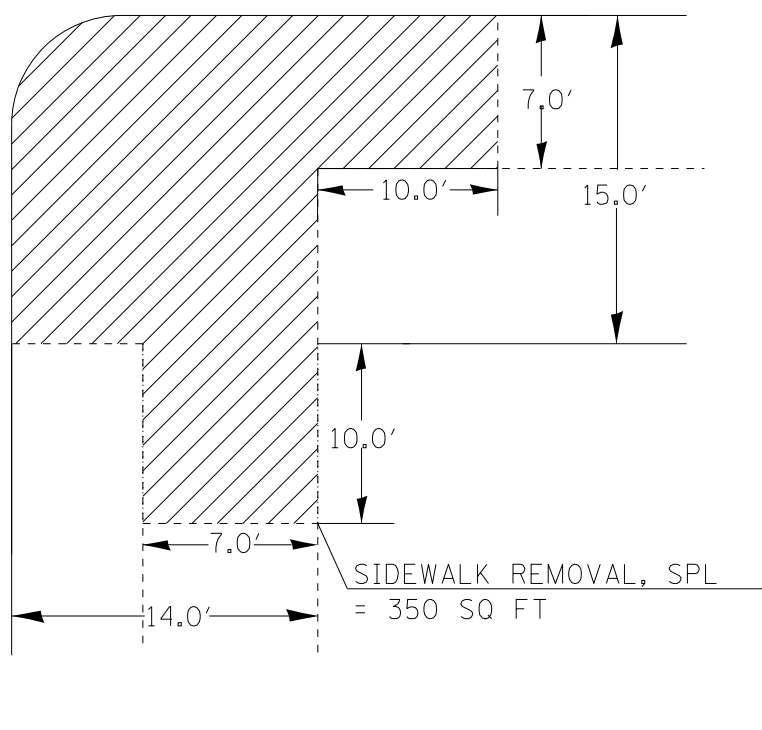
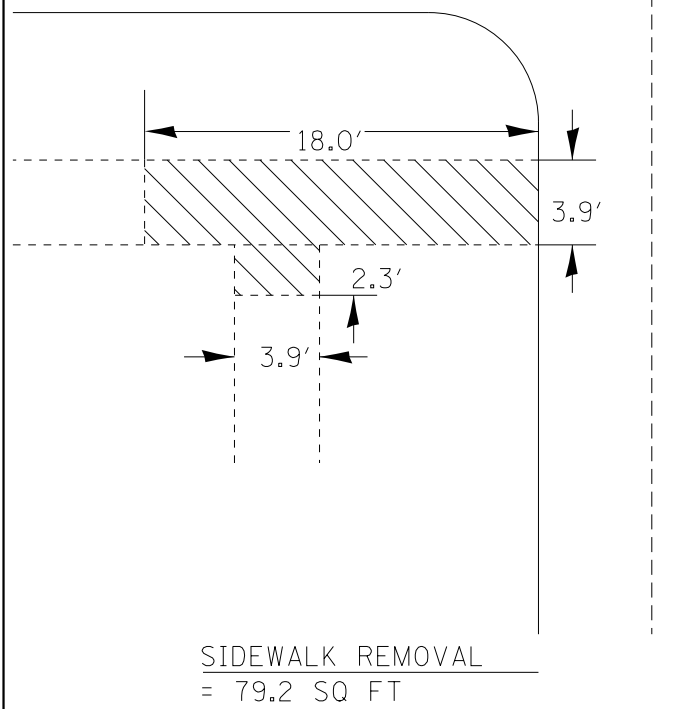
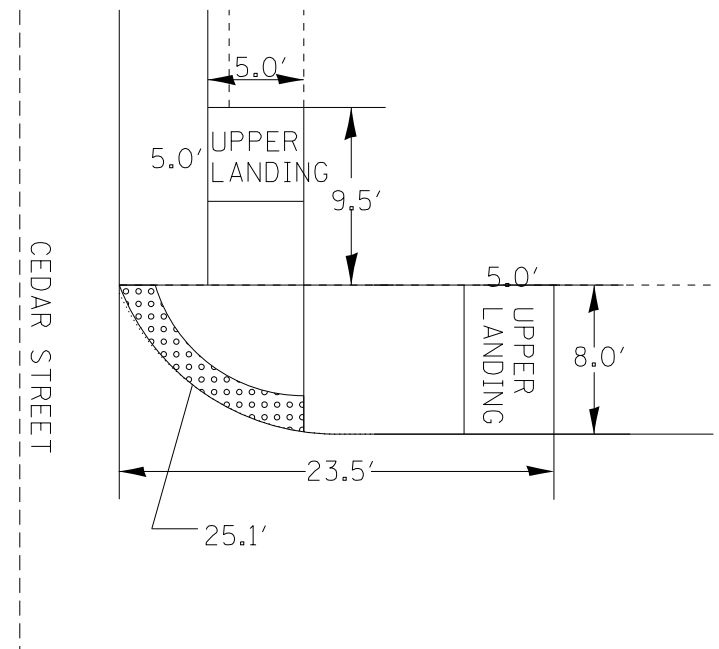
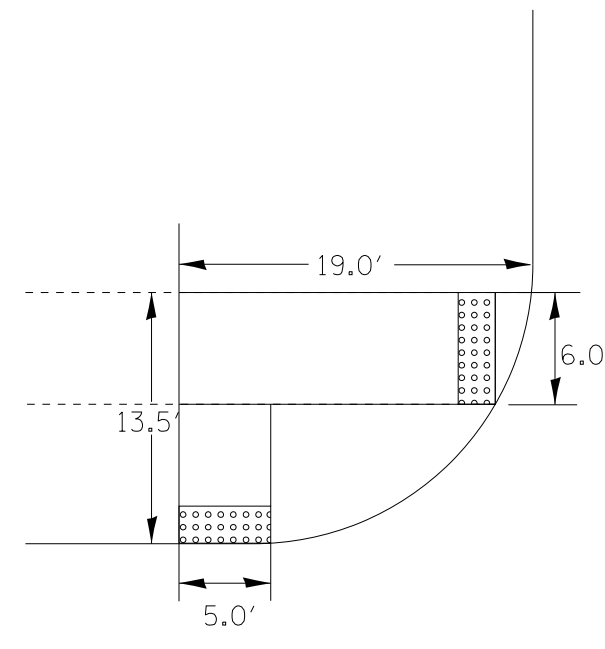
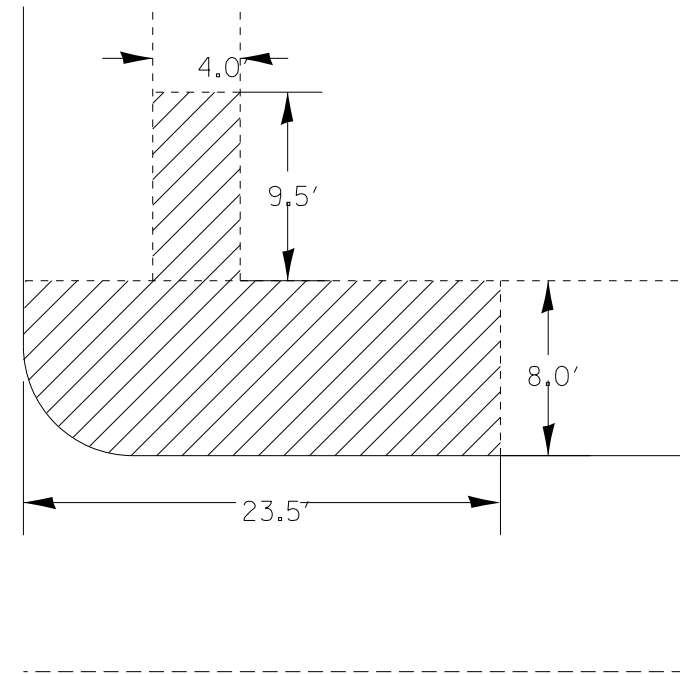
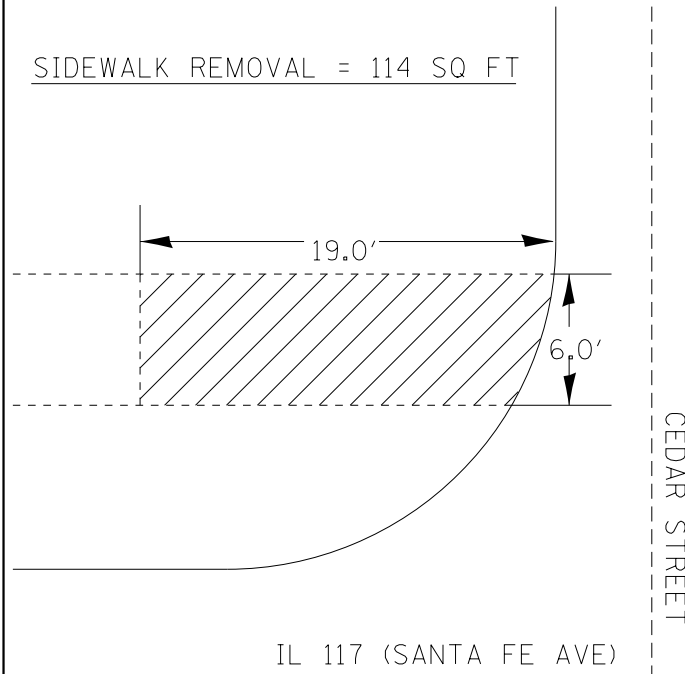

EXISTING

PROPOSED

REMOVAL

DRAWING NOT TO SCALE

FILE NAME = 68982.dgn	USER NAME = aubreys	DESIGNED -	REVISED -
Default		DRAWN -	REVISED -
	PLOT SCALE = 40.0000' / in.	CHECKED -	REVISED -
	PLOT DATE = 3/21/2013	DATE -	REVISED -

STATE OF ILLINOIS  
DEPARTMENT OF TRANSPORTATION

SIDEWALK DETAILS (IL 117/SANTA FE AND CEDAR ST)

SCALE: SHEET 25 OF 51 SHEETS STA. 564+50 TO STA. 565+00

F.A.S. RTE.	SECTION	COUNTY	TOTAL SHEETS	SHEET NO.
2361	101 RS-4; 102 RS-5	MARSHALL	51	25
CONTRACT NO. 68982				
ILLINOIS FED. AID PROJECT				

