

*USE STANDARD DETECTABLE WARNING W/ DIMENSIONS OF 5' X '2, UNLESS OTHERWISE NOTED.

SIDEWALK REMOVAL = 58.5 SQ FT

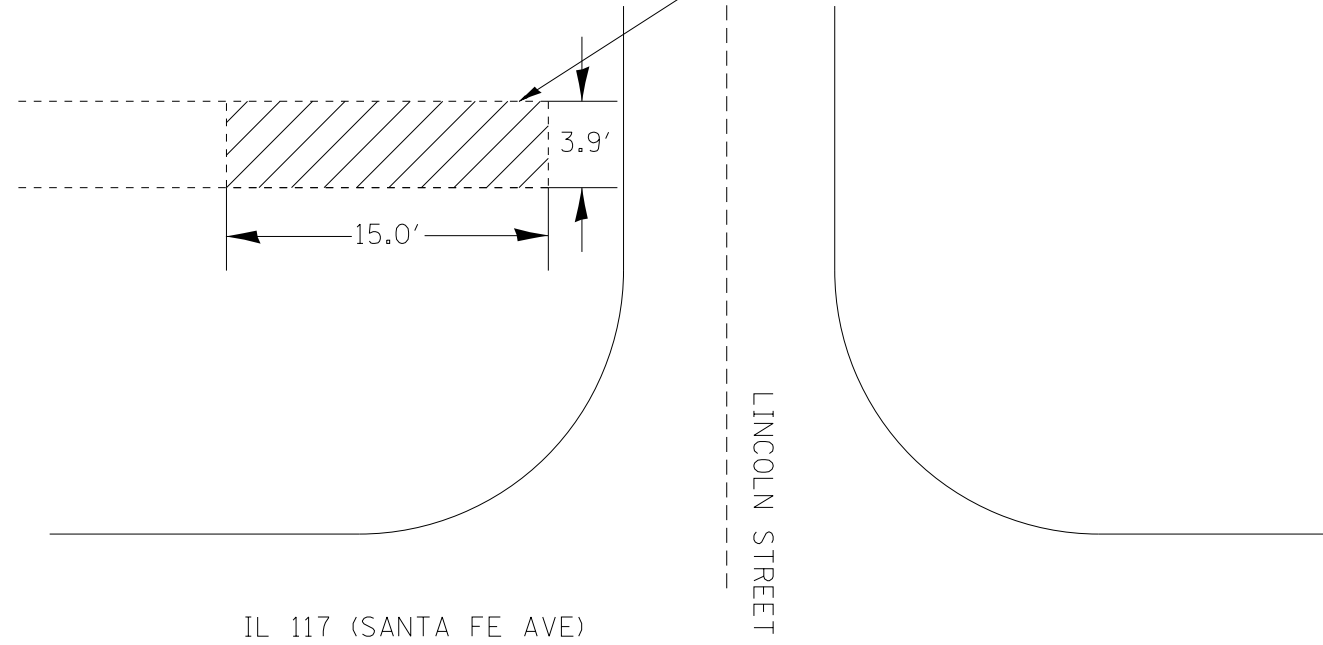

IL 117 (SANTA FE AVE)

LINCOLN STREET

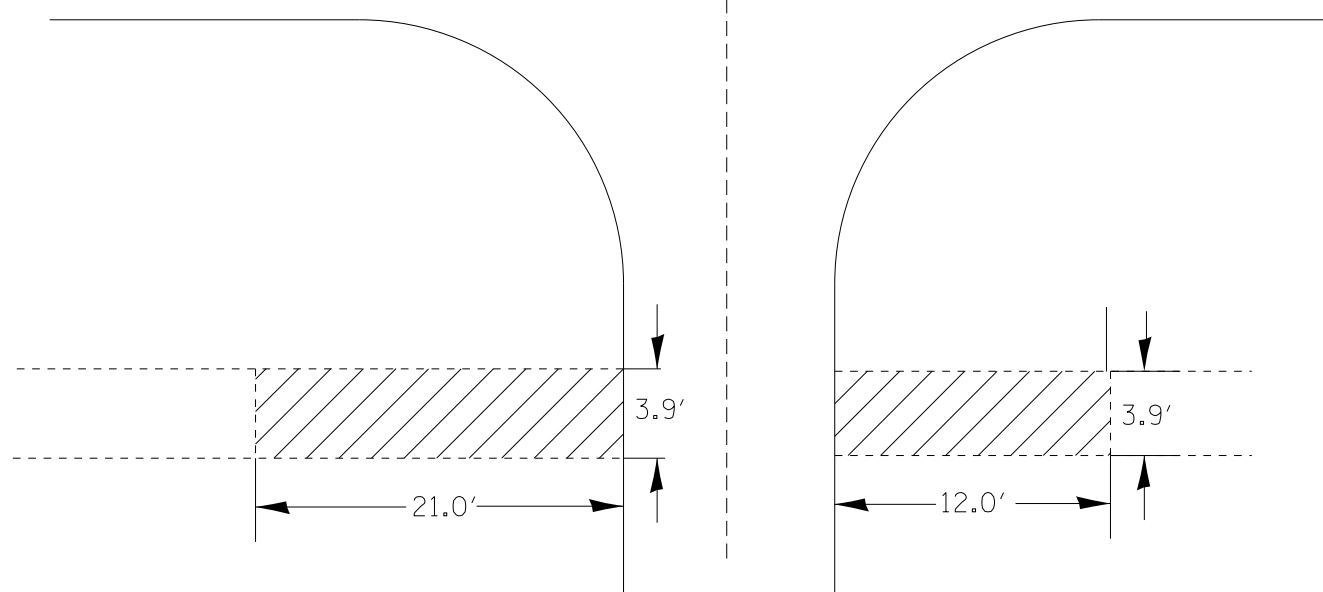

SIDEWALK REMOVAL = 62.4 SQ FT

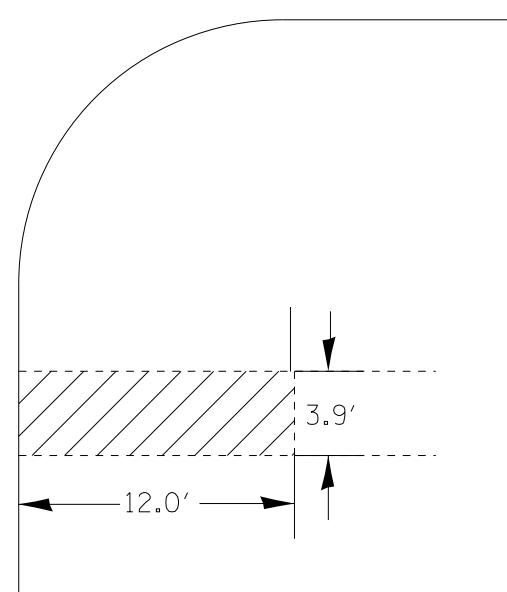

SIDEWALK REMOVAL = 46.8 SQ FT

EXISTING

PROP. PCC SIDEWALK = 85 SQ FT
USE RURAL DETAIL A-A AND B-B
DETECTABLE WARNINGS= 10 SQ FT

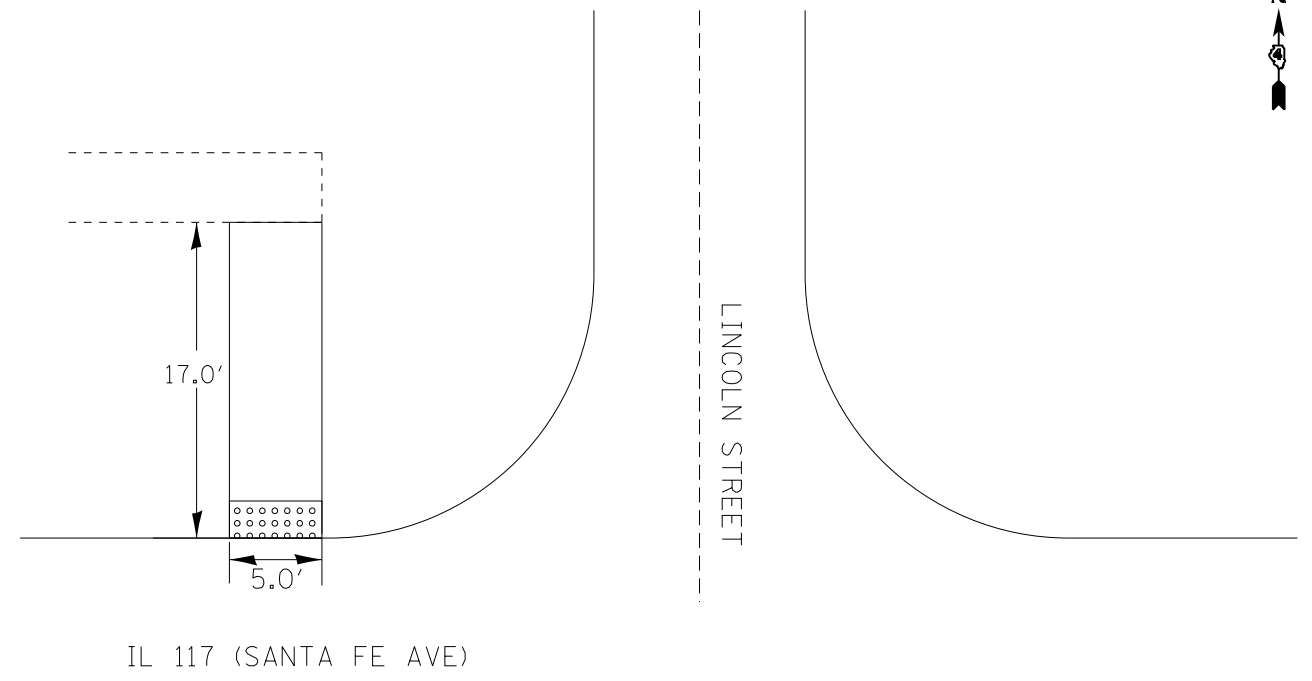

IL 117 (SANTA FE AVE)

LINCOLN STREET

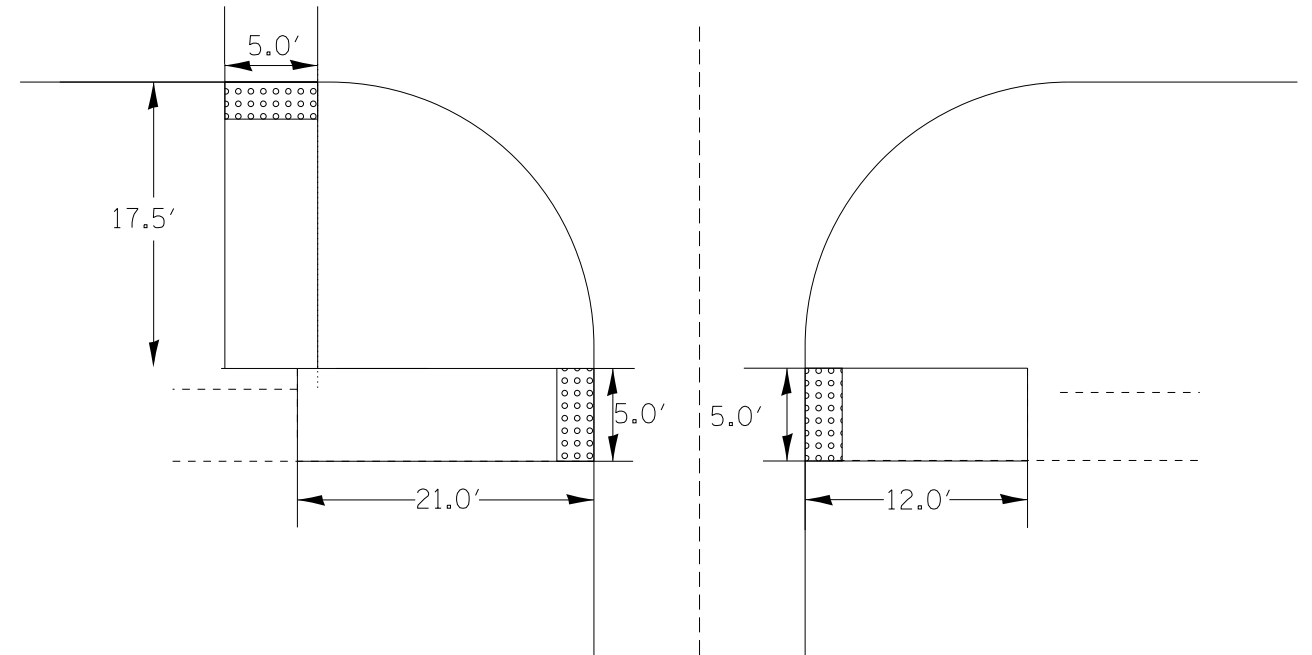

PROP. PCC SIDEWALK = 167.5 SQ FT
USE RURAL DETAIL A-A AND B-B
DETECTABLE WARNINGS= 20 SQ FT

PROP. PCC SIDEWALK = 60 SQ FT
USE RURAL DETAIL A-A AND B-B
DETECTABLE WARNINGS= 10 SQ FT

PROPOSED



REMOVAL

DRAWING NOT TO SCALE

FILE NAME = 68982.dgn	USER NAME = aubreys	DESIGNED -	REVISED -
Default		DRAWN -	REVISED -
	PLOT SCALE = 40.0000' / in.	CHECKED -	REVISED -
	PLOT DATE = 3/21/2013	DATE -	REVISED -

STATE OF ILLINOIS
DEPARTMENT OF TRANSPORTATION

SIDEWALK DETAILS (IL 117/SANTA FE AND LINCOLN ST)

SCALE: SHEET 22 OF 51 SHEETS STA. 554+00 TO STA. 554+70

F.A.S. RTE.	SECTION	COUNTY	TOTAL SHEETS	SHEET NO.
2361	101 RS-4; 102 RS-5	MARSHALL	51	22
CONTRACT NO. 68982				
ILLINOIS FED. AID PROJECT				